

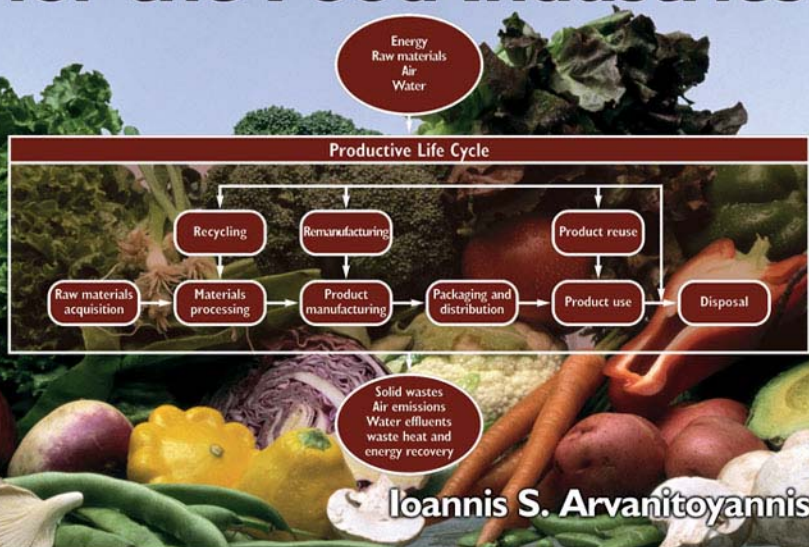

Waste Management for the Food Industries



Ioannis S. Arvanitoyannis



WASTE MANAGEMENT FOR THE FOOD INDUSTRIES

Food Science and Technology International Series

Series Editor

Steve L. Taylor
University of Nebraska – Lincoln, USA

Advisory Board

Ken Buckle
The University of New South Wales, Australia

Mary Ellen Camire
University of Maine, USA

Roger Clemens
University of Southern California, USA

Hildegarde Heymann
University of California – Davis, USA

Robert Hutkins
University of Nebraska – Lincoln, USA

Ron S. Jackson
Quebec, Canada

Huub Lelieveld
Bilthoven, The Netherlands

Daryl B. Lund
University of Wisconsin, USA

Connie Weaver
Purdue University, USA

Ron Wrolstad
Oregon State University, USA

A complete list of books in this series appears at the end of this volume.

Waste Management for the Food Industries

Authored by

Ioannis S. Arvanitoyannis (Dr, Ph.D.)

Associate Professor

University of Thessaly

Greece

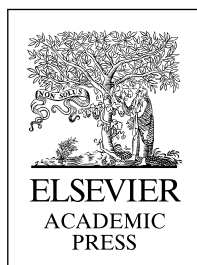

Amsterdam · Boston · Heidelberg · London · New York · Oxford
Paris · San Diego · San Francisco · Singapore · Sydney · Tokyo

Academic Press is an imprint of Elsevier
30 Corporate Drive, Suite 400, Burlington, MA 01803, USA
360 Park Avenue South, New York, NY 10010-1710, USA
525 B Street, Suite 1900, San Diego, California 92101-4495, USA
84 Theobald's Road, London WC1X 8RR, UK

First edition 2008

Copyright © 2008 Elsevier Inc. All rights reserved

No part of this publication may be reproduced, stored in a retrieval system or transmitted in any form or by any means electronic, mechanical, photocopying, recording or otherwise without the prior written permission of the publisher

Permissions may be sought directly from Elsevier's Science & Technology Rights Department in Oxford, UK: phone (+44) (0) 1865 843830; fax (+44) (0) 1865 853333; email: permissions@elsevier.com. Alternatively you can submit your request online by visiting the Elsevier web site at <http://elsevier.com/locate/permissions>, and selecting *Obtaining permission to use Elsevier material*

Notice

No responsibility is assumed by the publisher for any injury and/or damage to persons or property as a matter of products liability, negligence or otherwise, or from any use or operation of any methods, products, instructions or ideas contained in the material herein. Because of rapid advances in the medical sciences, in particular, independent verification of diagnoses and drug dosages should be made

Library of Congress Cataloging-in-Publication Data

A catalog record for this book is available from the Library of Congress

British Library Cataloguing in Publication Data

A catalogue record for this book is available from the British Library

ISBN: 9780123736543

For information on all Academic Press publications
visit our web site at <http://books.elsevier.com>

Typeset by Charon Tec Ltd (A Macmillan Company), Chennai, India
www.charontec.com

Printed and bound in the United States of America

08 09 10 11 12 9 8 7 6 5 4 3 2 1

Working together to grow
libraries in developing countries

www.elsevier.com | www.bookaid.org | www.sabre.org

ELSEVIER

BOOK AID
International

Sabre Foundation

*To my wife for her unfailing support and affection
throughout the long preparation of this book*

*To my three children (Iason, Artemis-Eleni, Nefeli-Kallisti)
for their warm-hearted smiles*

I.S. ARVANITTOYANNIS

This page intentionally left blank

Contents

Contributors	xi
Preface	xii
Abbreviations	xiv

PART 1 Environmental Management Systems: Applications and Potential	1
1 Potential and Representatives for Application of Environmental Management System (EMS) to Food Industries	3
<i>Ioannis S. Arvanitoyannis</i>	
Current state of Environmental Management System (EMS) implementation	4
Emissions and wastewater management	4
Food industry and agricultural waste	6
Beverage industry	9
Fruit and vegetable industry	9
Meat and poultry	10
Agricultural waste	10
Effects of pollution on organisms	12
Glass, chemicals and other products	13
Environmental attitudes and politics	15
Progress in alternative energy	16
Environmental impact assessment	19
2 ISO 14000: A Promising New System for Environmental Management or Just Another Illusion?	39
<i>Ioannis S. Arvanitoyannis</i>	
Introduction of ISO 14000	39
The emergence of global environmental awareness	40
Technical Committee 207 (TC 207)	43

	Environmental management systems (EMS)	45
	Benefits of implementing ISO 14000	49
	ISO 14000: a new approach	50
	ISO 14001: what it is and what it is not	51
	Similarity of ISO 14000 to other programs	53
	Applications of ISO 14000	59
	ISO 14000 and banks	61
	ISO 14000 and governments/education	62
	ISO 14001 implementation	63
	ISO 14010 – Environmental auditing	68
	Brief presentation of new ISO 14001:2004	71
	Overview of case studies reported on implementation of ISO 14001	72
3	ISO 14040: Life Cycle Assessment (LCA) – Principles and Guidelines	97
	<i>Ioannis S. Arvanitoyannis</i>	
	The concept of LCA	97
	The structure of LCA	98
	Examples of LCA studies on food production systems	99
	LCA case studies reported	106
	LCA in the future	126
	PART 2 Environmental Legislation	133
4	Presentation and Comments on EU Legislation Related to Food Industries – Environment Interactions	135
	<i>Ioannis S. Arvanitoyannis, Persefoni Tserkezou and Stefania Choreftaki</i>	
	Introduction	135
	Topics/categories covered under EU legislation	138
5	Presentation and Comments on USA and Canada Legislation Related to Food Industries – Environment Interactions	289
	<i>Ioannis S. Arvanitoyannis and Persefoni Tserkezou</i>	
	Introduction	289
	US legislation for environment	293
	Canadian legislation for environment	317
	PART 3 Waste Treatment Methodologies	343
6	Food Waste Treatment Methodologies	345
	<i>Ioannis S. Arvanitoyannis, Aikaterini Kassaveti and Demetrios Ladas</i>	
	Introduction	345
	Treatment methods	359

PART 4 Waste Treatment Methodologies of Foods of Plant Origin	411
7 Wine Waste Management: Treatment Methods and Potential Uses of Treated Waste	413
<i>Ioannis S. Arvanitoyannis, Demetrios Ladas and Athanasios Mavromatis</i>	
Introduction	413
Wine waste treatment methods	418
Main applications/constituents to be exploited	429
8 Olive Oil Waste Management: Treatment Methods and Potential Uses of Treated Waste	453
<i>Ioannis S. Arvanitoyannis and Aikaterini Kassaveti</i>	
Introduction	453
Olive oil production process and properties of OMW	454
Treatment methods	456
Uses	490
Disadvantages of several olive oil waste treatment methods	539
Inputs and outputs in olive oil industry	552
9 Fruit/Fruit Juice Waste Management: Treatment Methods and Potential Uses of Treated Waste	569
<i>Ioannis S. Arvanitoyannis and Theodoros H. Varzakas</i>	
Introduction	569
Treatment methods	570
Treatment of industrial water effluents	575
Uses of fruit wastes	578
Comparison of waste treatment methods	619
Conclusions	619
10 Cereal Waste Management: Treatment Methods and Potential Uses of Treated Waste	629
<i>Ioannis S. Arvanitoyannis and Persefoni Tserkezou</i>	
Introduction	629
Treatment methods	631
Uses of wheat, corn, rice, barley and oat wastes	681
11 Vegetable Waste Management: Treatment Methods and Potential Uses of Treated Waste	703
<i>Ioannis S. Arvanitoyannis and Theodoros H. Varzakas</i>	
Introduction	703
Treatment methods	704
New waste management technologies	715
Identification of different compounds in vegetable waste	716
Comparison of waste treatment methods	730
Conclusions	752

PART 5	Waste Treatment Methodologies of Foods of Animal Origin	763
12	Meat Waste Management: Treatment Methods and Potential Uses of Treated Waste	765
	<i>Ioannis S. Arvanitoyannis and Demetrios Ladas</i>	
	Introduction	765
	Primary treatment	768
	Secondary treatment	771
	Uses	782
13	Dairy Waste Management: Treatment Methods and Potential Uses of Treated Waste	801
	<i>Ioannis S. Arvanitoyannis and Aikaterini Kassaveti</i>	
	Introduction	801
	Treatment methods	804
	Uses	819
	Inputs and outputs in dairies	844
14	Fish Waste Management: Treatment Methods and Potential Uses of Treated Waste	861
	<i>Ioannis S. Arvanitoyannis and Aikaterini Kassaveti</i>	
	Introduction	861
	Treatment methods	864
	Uses of fish waste	882
	Inputs and outputs in fisheries	924
PART 6	Food Packaging Waste Treatment	939
15	Waste Management in Food Packaging Industries	941
	<i>Ioannis S. Arvanitoyannis</i>	
	Introduction	941
	Glass	950
	Aluminum	958
	Paper/carton	975
	Polymers	980
	Index	1047
	Series	1069

Contributors

Ioannis S. Arvanitoyannis, Associate Professor, University of Thessaly, Hellas (Greece)

Stefania Choreftaki, University of Thessaly, Hellas (Greece)

Aikaterini Kassaveti, University of Thessaly, Hellas (Greece)

Demetrios Ladas, University of Thessaly, Hellas (Greece)

Athanasios Mavromatis, Lecturer, University of Thessaly, Hellas (Greece)

Persefoni Tserkezou, University of Thessaly, Hellas (Greece)

Theodoros H. Varzakas, Assistant Professor, TEI Kalamata, Hellas (Greece)

Preface

The continuously increasing human population (more than 7 billion) has resulted in a huge demand for processed and packaged food. Food processing and food packaging have led to a substantial depletion of non-renewable resources. In fact, large amounts of water, air, electricity and fuel are consumed on a daily basis for food processing, transportation and preservation purposes. Apart from this, however, the lack of implementing a life cycle analysis (LCA), where all by-products or sub-products of food processing could effectively enter the Krebs cycle, is an omnipresent reality. All these incidents have had a very ominous effect on the quality of the environment, which has continued to deteriorate very rapidly over the last 20–30 years. Despite the agreements stipulated in the Montreal and Kyoto protocols and what was voted within the frame of the Green and White Bible, the truth is that the environment shows a rapidly declining trend.

Although the food industry is not one of the most heavily polluting, it contributes to a considerable extent to this already acute problem. Promising solutions consist of opting for 'green' processing technologies (implying zero/low consumption of non-renewable resources) in conjunction with usage of by-products and/or waste materials. The latter can prove to be very useful since they contain compounds with therapeutic actions (i.e. antioxidants in olive oil extraction, aromas in orange juice extraction). Another very important issue is food packaging materials which account for almost 5% of the total weight (15% of the total volume) of waste materials. Most of it is manufactured out of polymeric material (plastic). Recycling is a promising solution to this problem, but composting, landfilling and, occasionally, incineration are the most widely employed processes. Although these processes are of low cost, they do contribute heavily to high environmental pollution as well.

This book consists of 15 chapters, divided into the following parts:

Part 1: Environmental management systems: applications and potential

Part 2: Environmental legislation

Part 3: Waste treatment methodologies

Part 4: Waste treatment methodologies of foods of plant origin

Part 5: Waste treatment methodologies of foods of animal origin

Part 6: Food packaging waste treatment.

In Part 1, a presentation of the current environmental management systems' (EMS) situation is attempted, a comparison of the various EMS is made and emphasis is put on life cycle analysis because the latter represents one of the most promising and reliable approaches in terms of assessing the environmental impact of the employed processes. In Part 2, the main Directives of the EU and Acts of the USA and Canada are given in the form of comprehensive tables accompanied by the main points and a text summary. It is evident that EU legislation is much more flexible and changeable (many amendments in a short period) than the respective USA and Canadian legislation. Part 3 (Chapter 6) describes the various waste treatment methodologies such as drying, landfilling, thermal processes (incineration, pyrolysis, combustion), composting, anaerobic digestion, bioremediation, ozonation, electrolysis, evaporation, coagulation/precipitation. Informative tables are given where the method characteristics, advantages and disadvantages are included. Though a comprehensive chapter, it could have been much longer in view of the great number of waste treatment methods employed. Part 4 includes waste treatment methods of selected foods of plant origin (grape/wine, olive/olive oil, orange/lemon/juice, sugarcane/sugar, almond, wheat, maize, barley, rye) and the potential uses of treated waste. Part 5 follows the same line as Part 4 but is focused on waste treatment methods of foods of animal origin (meat, dairy and fish) and the potential use of their treated waste. Finally, Part 6 is a very comprehensive chapter covering all the packaging materials for food applications such as plastics, glass, carton, paper, metal, aluminum and combinations.

The aim of this book is to provide both general and practical knowledge and information about the current and potential waste treatment methods. It also contains extensive and thorough information related to the uses/applications of the ensuing treated waste. The large amount of updated information (many informative tables for waste treatment methodologies, treated waste uses and more than 3000 references) in this book will make it very useful to industrialists, academics and researchers.

Ioannis S. Arvanitoyannis
Associate Professor, UTH, Hellas (Greece)

Abbreviations

AA	Adipic acid
ABE	Activated Bleaching Earth
ADP	Abiotic resources Depletion Potential
AFB	Anaerobic Fluidized Bed
AFBR	Anaerobic Fluidized Bed Reactors
AFFR	Anaerobic Fixed Film Reactor
AGM	Atmospheric greenhouse model
AHF	Anaerobic hybrid filter
ALRP	Aluminum recycling by-product
ANOVA	Analysis of variance
AP	Acidification Potential
API	Air Pollution Index
API	American Petroleum Institute
APME	Association of Polymer Manufacturers in Europe
ASBR	Anaerobic Sequencing Batch Reactors
AX	Arabinoxylan
BAPEDAL	Indonesia Environmental Impact Management Agency
BAT	Best available techniques
BFBC	Fluidized bed combustion
BHA	Butylated-hydroxyanisole
BHT	Butylated-hydroxytoluene
bio-CNG	bio-compressed natural gas
BMP	Biochemical Methane Potential
BNR	Biological Nutrient Removal
BOD	Biological Oxygen Demand
BPF	By-product feedstuffs
BSE	Bovine Spongiform Encephalopathy
BSS	Biofilm Support System
BW	Black Water
CAA	Clean Air Act
CAFOs	Confined animal feeding operations

CAP	Common Agricultural Policy
CBA	Cost-benefit analysis
CBC	Circulating bed combustor
CBOD	Carbonaceous Biochemical Oxygen Demand
CCGT	Combined-cycle gas turbine
CCP	Critical Control Points
CERCLA	Comprehensive Environmental Response, Compensation, and Liability Act
CERES	Crop estimation through resource and environment synthesis
CFB	Circulating fluidised bed
CFD	Computational fluid dynamics
CFP	Common Fisheries Policy
CFR	Code of Federal Regulations
CHP	Combined heat and power
CIP	Cleaning-in-place
CM	Chicken manure
CMA	Chemical Manufacturers Association
CMRs	Carcinogens, mutagens and reproductive toxins
CNG	Compressed Natural Gas
CO	Carbon Monoxide
COD	Chemical Oxygen Demand
COPD	Chronic Obstructive Pulmonary Disease
COPE	Compensation for Oil Pollution in Europe
CP	Crude protein
CPB	Corrugated paperboard
CPM	Chemical Pest Management
CS	Cattle slurry
CST	Critical Surface Time
CSTR	Continuous Stirred Tanks Reactors
CWA	Clean Water Act
CZMA	Coastal Zone Management Act
DAA	Dodecylamine acetate
DAF	Dissolved Air Flotation
DBSNa	Dodecylbenzenesulfonic acid–sodium salt detergent
DCDS	Digested Cow Dung Slurry
DCOD	Dissolved Chemical Oxygen Demand
DDGS	Distiller's Dried Grains with Solubles
DDT	Dichloro- Diphenyl- Trichloroethane
DEG	Diethylene glycol
DF	Diafiltration
DH	Degrees of hydrolysis
DHA	Docosahexanoic acid
DIS	Draft International Standard
DM	Dry matter
DO	Dissolved Oxygen

DOE	Department of Energy
DPWW	Dairy Parlour Wastewater
DSFF	Downflow Stationary Fixed Film
DSN	Data Source Name
DTPA	Diethylene triamine pentaacetic acid
EA	Environmental Auditing
EAA	Essential amino acids
EAA	Ethylene acrylic acid
EAPS	Environmental aspects of product standards
EC	Electric conductivity
EC	European Commission
ECCP	European Climate Change Programme
ECE	Economic Commission for Europe
ED	Electrodialysis
EDTA	Ethylenediamine tetraacetic acid
EDX	Energy dispersive X-rays
EEA	European Environment Agency
EEC	European Economic Community
EEl	Energy Efficiency Indicator
EES	Environmental Effects Statement
EFTA	European Free Trade area
EG	Exhausted grape marc
EIA	Environmental Impact Assessment
EQ	Environmental Impact Quotient
EIS	Environmental Impact Statement
EL	Environmental Labelling
ELV	Environmental Load Value
EM	Environmental Management
EMA	Environmental Management Act
EMAS	Eco-Management and Audit Scheme
EMS	Environmental Management System
EOPC	Extracted olive press cake
EP	Environmental Performance
EP	Eutrophication Potential
EPA	Eicosapentanoic acid
EPA	Environmental Protection Act
EPA	Environmental Protection Agency
EPE	Environmental Performance Evaluation
EPR	Extended Producer Responsibility
EPR	Electron Paramagnetic Resonance
EPS	Expanded polystyrene
EQOs	Environmental Quality Objectives
EQSs	Environmental Quality Standards
ERenEf	Energy renewability efficiency

ERS	Economic Research Service
ES	Environmental Statement
ESA	Endangered Species Act
ESH	Environment, safety and health
EPS	Expanded polystyrene
ETI	Environmental Technology Initiative
ETS	Ecological Treatment System
EU	European Union
EVA	Ethylene-vinyl acetate
FA	Fatty acid
FAME	Fatty acid methyl ester
FBC	Fluidised Bed Combustor
FC	Faecal Coliforms
FE	Feed efficiency
FFA	Free Fatty Acids
FFCA	Federal Facility Compliance Act
FGDP	Flue gas desulfurization by-product
FIFRA	Federal Insecticide, Fungicide and Rodenticide Act
FIFO	First-in, first-out
FP	Flash pyrolysis
FPH	Fish Protein Hydrolysates
FR	Federal Register
FVFMSW	Fruit and vegetable fraction of municipal solid wastes
FVSW	Fruits and vegetable solid wastes
FWW	Fruit and vegetable wastes
FW	Fish waste
FW	Freshwater fish
GATT	General Agreement on Tariffs and Trade
GC	Gas chromatographer
GHG	Greenhouse gas
GLC	Gas-liquid chromatography
GLP	Good Laboratory Practice
GM	Grape marc
GMOs	Genetically Modified Organisms
GS	Gas separation
GS	Grape stalk
GSE	Grape seed extracts
GSP	Generalised system of preferences
GSPC	Grape seed proanthocyanidins
GVM	Gesellschaft für Verpackungsmarktforschung
GWC	Green Waste Composts
GWP	Global Warming Potential
HACCP	Hazard Analysis Critical Control Points
HAPs	Hazardous Air Pollutants

HC	Hydrocarbon
HCFCs	Hydrochlorofluorocarbons
HD	Hexane diamine
HDL	High-density lipoproteins
HDPE	High density polyethylene
HFCs	Hydrofluorocarbons
HHV	Higher Heating Value
HM	Heavy metal
HMTA	Hazardous Materials Transportation Act
HMWPP	High molecular weight polypropylene
HPAEC-PAD	High-pressure anion-exchange chromatography pulsed amperometric detection
HRT	Hydraulic Retention Times
HUFA	Highly Unsaturated Fatty Acids
IC	Ion chromatography
ICZM	Integrated Coastal Zone Management
IFGT	Indirectly fired gas turbine
IGCC	Integrated Gasification Combined Cycle
IISD	International Institute for Sustainable Development
IMO	International Maritime Organisation
IMPEL	Implementation and Enforcement of Environmental Law
IMS	Intelligent Motion Systems
IOEA	Input-output energy analysis
IPA	Isopropyl alcohol
IPCC	Intergovernmental Panel on Climate Change
IPD	Isophorone diamine
IPM	Integrated Pest Management
IPPC	Integrated Pollution Prevention and Control
IRMS	Isotope ratio mass spectrometry
IRR	Internal Rate of Return
ISO	International Standardization Organization
LAR	Lactate Aerobic
LCA	Life Cycle Analysis
LCFA	Long-chain fatty acid
LCIA	Life Cycle Impact Assessment
LCS	Ligno-cellulosic substrate
LDL	Low-density lipoproteins
LDPE	Low density polyethylene
LEFR	Laminar entrained flow react
LHV	Lower heating value
LiP	Lignin peroxidase
LLA	L-lactide

LLDPE	Linear low-density polyethylene
LLRPA	Low Level Radioactive Policy Act
LPG	Liquefied petroleum gas
LR	Loading rate
MACT	Maximum Achievable Control Technology
MAFF	Ministry of Agriculture, Fisheries and Food
MAP	Manure Action Plan
MB	Mass Balance
MB	Methylene blue
MB	Moving bio-film
MBM	Meat and bone meal
MBR	Membrane bioreactor
MDI	Methylenebis (phenyl isocyanate)
MEE	Metabolizable energy efficiency
MEET	Multistaged Enthalpy Extraction Technology
MF	Microfiltration
MFD	Material Flow Diagram
MI	Market-incentive
MIR	Mid Infrared
MnP	Manganese-dependent peroxidase
MP	Mandarin peels
MPRSA	Marine Protection, Research and Sanctuaries Act
MRL	Maximum Residue Limit
MS	Mass spectrometry
MSW	Municipal solid waste
MUDS	Marine Underwater Depuration System
MW	Meat waste
NAA	Nonattainment area
NAAQS	National Ambient Air Quality Standards
NASA	National Aeronautics and Space Administration
NCP	National Contingency Plan
NEC	No effect concentration
NEPA	National Environmental Policy Act
NF	Nanofiltration
NFE	Nitrogen free extracts
NGCC	Natural Gas Fired Combined Cycle
NGOs	Non-governmental organisations
NIR	Near infrared
NMR	Nuclear magnetic resonance
NOEC	No-observed-effect-concentration
NPDES	National Pollutant Discharge Elimination System
NPN	Non-protein-nitrogen
NPV	Net Present Value

NSC	Non-selected compost
NTA	Nitrilotriacetic acid
OAERRE	Oceanographic Applications to Eutrophication in Regions of Restricted Exchange
OandG	Oil and Grease
OBW	Organic Biological Wastes
ODA	Octadecanedioic acid
ODP	Ozone Depletion Potential
OECD	Organisation of Economic Co-operation and Development
OFMSW	Organic fraction of municipal solid wastes
OHS	Occupational Health and Safety
OL	Olive leaves
OM	Oversize materials
OMSR	Olive mill solid residue
OMSW	Olive mill solid wastes
OMW	Olive mill wastewaters
OOC	Olive oil cake
OP	Orthophosphate
OPA	Oil Pollution Act
OPC	Olive press cake
ORL _s	Organic loading rate
OSHA	Occupational Safety and Health Administration
OTB	Olive tree branches
OTL	Olive tree leaves
PAC	Powdered Activated Charcoal
PACM	(Para-aminocyclohexyl)-methane
PAHs	Polynuclear aromatic hydrocarbons
PBM	Population Balance Model
PBTs	Persistent, bioaccumulative and toxic substances
PCB	Polychlorinated biphenyl
PCDD	Polychlorinated dibenzo dioxins
PCDF	Polychlorinated dibenzofurans
PCL	Poly (ϵ -caprolactone)
PCSD	President's Council on Sustainable Development
PCTs	Polychlorinated terphenyls
PE	Person equivalents
PE	Polyethylene
PES	Polyethersulfone
PET	Polyethylene terephthalate
PFP	Passion fruit peels
PF	Pulverized Fuel
PFCs	Perfluorocarbons
PFD	Process Flow Diagram
Ph	Phenol

PIC	Prior Informed Consent
PM	Particulate matter
PMMA	Poly(methyl methacrylate)
PO	Propylene oxide
POFP	Photo-Oxidants Formation Potential
POME	Palm oil mill effluents
POPs	Persistent Organic Pollutants
POTWs	Publicly-owned treatment works
PP	Polypropylene
PPA	Pollution Prevention Act
ppm	Parts per million
PS	Polystyrene
PTA	Purified terephthalic acid
PV	Pervaporation
PVA	Poly(vinyl alcohol)
PVC	Polyvinyl chloride
PY	Pyrolysis
QMS	Quality Management Systems
R	Recovery
RCRA	Resource Conservation and Recovery Act
RED	Reregistration Eligibility Decision
REACH	Registration, evaluation, authorisation and restriction of chemicals
RfD	Reference Dose
RO	Reverse Osmosis
RS	Reducing sugars
SAGE	Strategic Advisory Group for the Environment
SARA	Superfund Amendments and Reauthorization Act
SBR	Sequencing batch reactor
SCCP	Scientific Committee on Consumer Products
SCENIHR	Scientific Committee on Emerging and Newly Identified Health Risks
SCHER	Scientific Committee on Health and Environmental Risks
SCLCA	Soil Conservation and Land Care Act
SCOD	Soluble Chemical Oxygen Demand
SCP	Service Control Point
SDCP	Solar dried citrus pulp
SDM	Self Diagnosis Method
SDWA	Safe Drinking Water Act
SEM	Scanning electron microscopy
SETAC	Society for Environmental Toxicology and Chemistry
SFE	Supercritical fluid extraction
SH	Sulfhydryl

SHPH	Shrimp head protein hydrolysates
SLCC	Social Life Cycle Costs
SMB	Simulated moving bed
SMB	Soil Microbial Biomass
SMCRA	Surface Mining Control and Reclamation Act
SMEs	Medium-sized enterprises
SOM	Soil organic matter
SOSEA	Strategic Overview of Significant Environmental Aspects
SPH	Squid protein hydrolysate
SPM	Suspended Particulate Matter
SPS	Sanitary and Phytosanitary Agreement
SQP	Successive quadratic programming
SR	Shredder residue
SRT	Solid retention time
SS	Suspended solids
SSF	Simultaneous saccharification and fermentation
SSF	Solid-state fermentation
STEP	Strategies for Today's Environmental Partnership
SUV's	Sports utility vehicles
SW	Saltwater
SWE	Subcritical water extraction
SWG	Supercritical water gasification
SWNZ	Sustainable Winegrowing New Zealand
SWOT	Strength/weakness/opportunity/threat
TAC	Triallyl cyanurate
TAN	Total Ammonia Nitrogen
TAN	Total Available Nitrogen
TandD	Terms and definitions
TC	Technical Committee
TCDD	Tetrachlorodibenzo-p-Dioxin
TCOD	Total Chemical Oxygen Demand
TDS	Total Dissolved Solids
TGA	Thermogravimetric analyzers
TKN	Total kneldahl nitrogen
TMA	Trimethylamine
TMAH	Tetramethylammonium hydroxide
TMP	Transmembrane pressure
TN	Total nitrogen
TOC	Total Organic Carbon
TON	Total Organic Nitrogen
TP	Thermocalcic precipitation
TP	Total Phosphorus
TPE	Total protein efficiency
TPhT	Tetraphenyl tin

TPO	Thermoplastic polyolefin
TPUs	Toxicity/persistence units
tpy	tons per year
TR	Tilapia residue
TS	Total solids
TSCA	Toxic Substances Control Act
TSD	Treatment, storage or disposal
TSM	Total suspended matter
TSS	Total Suspended Solids
TVN	Total Volatile Nitrogen
UASB	Upflow Anaerobic Sludge Blanket
UBCs	Used beverage cans
UF	Ultrafiltration
UK	United Kingdom
UMTRCA	Uranium Mill Tailings Radiation Control Act
UN	United Nations
UNECE	United Nations Economic Commission for Europe
UNEP	United Nations Environment Programme
USA	United States of America
USDA	United States Department of Agriculture
USEPA	United States Environmental Protection Agency
UTS	Ultimate Tensile Strength
UV	Ultraviolet
UWC	Urban waste composts
VBN	Volatile basic nitrogen
VFA	Volatile fatty acids
VFG	Vegetable, fruit and garden
VOC	Volatile Organic Chemical
VORW	Vegetable oil refinery wastewater
VOs	Vegetable oils
VPP	Voluntary Protection Programs
vPvBs	Very persistent and very bioaccumulative substances
VRR	Volume Reduction Ratio
VS	Volatile solids
VSS	Volatile suspended solids
VW	Vegetation waters
WAS	Waste activated sludge
WASTED	Waste Analysis Software Tool for Environmental Decisions
WAXDP	Wide-angle X-ray diffraction patterns
WEEE	Waste Electrical and Electronic Equipment
WEF	Water Environment Federation
WHC	Water Holding Capacity
WHO	World Health Organization

WL	Wine lees
WO	Wet oxidation
WS	Wheat straw
WSC	Water Soluble Carbohydrates
WSOC	Water Soluble Organic Carbon
WTO	World Trade Organisation
XRD	X-ray diffraction
ZBF	Zeolite bed filtration

Environmental Management Systems: Applications and Potential

PART

1

- 1 Potential and Representatives for Application of Environmental Management System (EMS) to Food Industries 3
- 2 ISO 14000: A Promising New System for Environmental Management or Just Another Illusion? 39
- 3 ISO 14040: Life Cycle Assessment (LCA) – Principles and Guidelines 97

This page intentionally left blank

Potential and Representatives for Application of Environmental Management System (EMS) to Food Industries

Ioannis S. Arvanitoyannis

Current state of Environmental Management System (EMS) implementation	4
Emissions and wastewater management	4
Food industry and agricultural waste	6
Beverage industry	9
Fruit and vegetable industry	9
Meat and poultry	10
Agricultural waste	10
Effects of pollution on organisms	12
Glass, chemicals and other products	13
Environmental attitudes and politics	15
Progress in alternative energy	16
Environmental impact assessment	19

Current state of Environmental Management System (EMS) implementation

The management of environmental issues is of growing interest nowadays. There is a need to understand the important environmental impacts on the community and then consider the advantages and disadvantages associated with various levels of environmental management (Norman, 1997). The Ministers of Environment of the United Nations Economic Commission for Europe (UN/ECE) reaffirmed their strong commitment, developed over the three previous Ministerial Conferences in Dobris (1991), Lucerne (1993) and Sofia (1995), to cooperate on environmental protection within the ECE region. They committed themselves to comply with the obligations arising from the stipulated declaration and environmental conventions. They promised to enhance their efforts toward a sustainable development by supporting the work of the United Nations Environment Programme (UNEP) and other global organization conventions (4th Ministerial Conference) (Boudouropoulos and Arvanitoyannis, 1999, 2000).

Emissions and wastewater management

Consideration of environmental issues is growing, bringing about the need for more sophisticated control of industrial emissions and waste and faster and more advanced on-board diagnosis (Spetz *et al.*, 1998). Pollution can originate from mobile (emissions for vehicles) or stationary sources (industries) (Treshow and Anderson, 1991). There is a growing interest in reaching zero emission in power plants, similarly to hazard analysis and critical control points (HACCP) for zero-defective products (Spetz *et al.*, 1998). Quantification, control and modeling of wastewater emissions received greater attention in 1999. The Clean Air Act Amendments (CAA) have established regulatory requirements which considerably affected wastewater operations (De Hollander, 1998). The Water Environment Federation (WEF) sponsored a conference on water re-use and water reclamation (Van Riper and Geselbracht, 1998).

Chemical sensors operating at high temperatures and fast enough to record infinitesimal time changes between an oxidizing and reducing ambient can be used for cylinder-specific monitoring of petrol car engines. Gas molecules, like carbon monoxide, reacting with oxygen will lower the sensor signal, while decomposition of nitric oxide releases oxygen on the surface leading to a stronger sensor signal (Spetz *et al.*, 1998). The first report on gas-sensitive field-effect devices based on silicon with a catalytic gate of palladium was published in 1975 (Lundstrom *et al.*, 1975). Chemical sensors with catalytic metal gates operating at high temperatures provided new horizons for emission control. Their operation principle is very simple and based on surfaces/interfaces phenomena with very small time constants, thus enabling very fast responses. They also constitute an interesting combination of material physics, heterogeneous catalysis, in conjunction with electronic devices (Spetz *et al.*, 1998).

The CAA requires industrial facilities to address the accidental release of regulated substances to the community and also sets regulations governing emissions of hazardous

air pollutants (HAPs) from wastewater using maximum achievable control technology (MACT) (Spetz *et al.*, 1998). In a case study for a publicly owned installation treatment in Virginia, controlled by industrial users, the wastewater had a high volatile organic chemical (VOC) content, which was stripped and emitted into the atmosphere. The standards for publicly owned installation treatment implemented a financially viable controlled technological approach to comply with state and federal clean air laws (Rogers and Steidel, 1998). Several traditional treatment processes can be used to reduce the VOC content of waste and comply with air emissions requirements, such as closed sewer systems, nitrogen- or gas-blanketing vessels and strippers on biological reactors (Venkatesh, 1997).

Wastewater can be purified by various treatments. The natural treatments can be classified into several categories:

- 1 soil-based systems
- 2 wetland systems, which include free water surface, submerged flow and vertical flow systems; aquatic systems, including pond and floating aquatic plant systems
- 3 on-site systems
- 4 phyto-remediation.

In soil-based systems, a study in overland flow, where the phosphorus removal from swine lagoon effluent was examined, showed that system slope did not affect sediment phosphorus concentrations, even at various application rates (Liu *et al.*, 1997). The use of constructed wetlands showed advantages, such as low cost and ease of incorporation into agricultural systems, whereas the main drawbacks were the required training. Wastewater treatment is the primary goal of many wetland systems, followed by ancillary benefits of public use and wildlife habitat (Knight, 1997). Aquatic systems and, more specifically, waste-stabilization ponds, could be implemented by means of sustainable development. The spatiotemporal dynamics and removal efficiency of pollution-indicator bacteria were studied in two high-rate oxidation ponds. Although bacteria removal was correlated with season (highest removal in summer), removal was always well correlated with retention time. Comparison with treatment lagoons showed advantages for the high-rate ponds (Bahlaui *et al.*, 1998). The high land area requirements and limited cool season growth in temperate climates proved to be significant limitations in floating aquatic plant systems. Although biological oxygen demand (BOD), total suspended solids (TSS) and algae removal is favorable in duckweed treatment systems, the limited nitrogen removal constitutes an impediment to extensive implementation (White and Burken, 1998).

Numerous articles and reviews have summarized and evaluated available water reclamation processes to meet current water-quality requirements. A seven-month pilot-plant study in Los Angeles County (California) evaluated three filtration systems for water reuse using high-purity oxygen-activated sludge plant effluent: a deep-bed anthracite filter, a shallow depth pulsed-bed sand filter and a continuous backwash deep-bed sand filter. All three filters were capable of consistently meeting the State of California's effluent turbidity limit and were characterized by similar costs (Kuo *et al.*, 1997). Field-scale evaluation of gravel-bed hydroponic wetlands in Egypt

demonstrated the capacity for removing eggs of human parasites and producing effluents which met the World Health Organization (WHO) microbiological guidelines for reuse (Stott *et al.*, 1997). Conventional reclamation technologies were judged too expensive for rural communities in Brazil, so treatment of degrittied wastewater through grass was investigated at two sites leading to promising results (Freire, 1997).

Food industry and agricultural waste

The problem of classification arose when it came to describing the regulatory aspects of composting food processing waste. Solid, agricultural and/or industrial wastes were of great concern, as well as the marketability of composted materials. The impact of CAA on food processing waste operations identified yeast manufacturing, cellulose food casing manufacturing and vegetable oil production as target industries for future specific regulations (Walsh *et al.*, 1993).

Dairy industry

A large portion of the chemicals used in the dairy industry has been traditionally discharged in the dairy wastewater. The type and quantity of chemicals used, and the method of wastewater treatment employed, substantially affected the extent of environmental pollution (Pankakoski *et al.*, 1993). An ice cream factory was one of two examples reported on waste reduction programs. After implementation of appropriate measures, BOD was reduced by 63% with investment costs for the post-control wastewater treatment system dropping by 43% (Hiddink, 1995). The ecological evaluation of dairy chemicals shows the impact of individual chemicals on the environment. Retail samples of cow milk were collected in the UK, both in winter and summer, and analyzed for ortho and non-ortho substituted polychlorinated biphenyls (PCBs). The determined values varied in the range 2–25 ng/kg and 0.05–0.6 ng/kg for the ortho and non-ortho substituted PCBs, respectively (Krokos *et al.*, 1996). The concentrations of polychlorinated dibenzo dioxins and dibenzofurans (PCDD/F) in human blood and human milk from non-occupationally exposed persons were determined in the vicinity of a municipal waste incinerator in Germany. Since the individual concentrations of PCDD/F in blood fat ranged within acceptable limits, it was concluded that no direct health hazard related to PCDD/F emissions from the local waste incinerator should be expected (Deml *et al.*, 1996).

Acids and alkalis, due to be replaced within the frame of a cleaner environment, seem to be generally less problematic than surfactants. However, this does not imply that cleaning should be conducted only with caustic soda and nitric acid. Additives are added to optimize the cleaning effectiveness of the detergents. When choosing additives, ecological aspects have to be considered as well. This becomes a problem for the industry because all the new products have to be analyzed for their environmental effects. The end-users usually buy a mixed product and they have problems on how to treat the contained chemicals. Therefore, the manufacturers have to report their findings related to the environmental impacts of their products (Pankakoski *et al.*, 1993). DDT residues in numerous milk samples were determined by using gas–liquid chromatography (GLC) and possible links between DDT exposure and breast cancer were investigated (Deka

et al., 1996). Although the determined DDT levels in human milk were attributed to campaigns against malaria and partly to DDT in fatty foods, no clear-cut connection between DDT and breast cancer could be established (Lopez-Carillo *et al.*, 1996). Process water in a dairy factory should be of drinking quality. When the dairy factory employs sources such as surface water, groundwater and condensates, considerable attention to meeting quality requirements is needed. These controls of water quality should be incorporated into the quality management system of a dairy factory, specifying both frequency and parameters to be checked (Hiddink, 1995; Boudouropoulos and Arvanityannis, 2000).

Fermentation industry

Brewery waste

Wastewater from fermentation industries is characterized by variable flow rates, often seasonal in nature, and high in organic loading, BOD and COD (chemical oxygen demand), low pH and high carbon-to-nitrogen (C:N) ratios (Grismer and Shepherd, 1998). In a review where the performance of anaerobic and aerobic biological wastewater treatment processes at a German brewery was compared, the former treatment achieved 91% COD reduction, whereas the aerobic treatment averaged 76% reduction (Mayer, 1995). An anaerobic fluidized bed (AFB) reactor treating brewery wastewater at 25°C achieved a COD removal of 85% and hydraulic retention times (HRT) of 2.5 h. The average biogas production rate was 0.45 m³kg⁻¹ COD removed, out of which 72% was CH₄. After seven days aerobic treatment of brewery wastewater, its pH rose from 6.5 to 8.9, while the BOD and suspended solids were reduced by 67% and 75%, respectively (Liang *et al.*, 1997).

The effects of various mixing rates of brewery wastewater with municipal solid waste on methane generation and landfill leachate were studied by using laboratory columns. It was found that codisposal of brewery wastewater stimulated methane production and did not negatively affect the leachate quality in terms of pH or volatile fatty acid concentrations. At very high loading organic rates, however, leachate quality temporarily deteriorated, as elevated concentrations of acetate and propionate were detected (Rahim and Watson-Craik, 1997). In a study where potential disinfection interferences by organic nitrogen compounds, such as those present in high concentrations in brewery effluent, may occur, the results showed that wastewater containing high ratios of total organic nitrogen to ammonia (TON:NH₃) was poorly disinfected by aqueous chlorine. Furthermore, disinfection rate tended to decrease with increasing TON:NH₃ ratios (Scully *et al.*, 1996). The operation of anaerobic plants for wastewater, including brewery wastewaters in Germany was reviewed. A survey was conducted to identify filamentous microorganisms in six activated sludge plants. A gram-positive, Neisser negative filament resembling both *Microthrix* spp. and *Nostocoida limicola* was the predominant filament in sludge from a plant treating brewery wastewater (Weathers, 1996).

Winery waste

Treatment of winery wastewater was evaluated both on a laboratory and industrial scale. The treatment of winery wastewater using a full-scale, modular, multistage activated sludge treatment plant was examined. The removal of COD averaged 98% when

the influent COD varied between 2000 and 9000 mg/l. The plant proved to be flexible enough to withstand large variations in the temperature, hydraulic, and COD loading rate, and was shown to have a low running cost. Studies in Portugal describe 1 m³ pilot-plant studies of the winery wastewater treatment capability of an adsorption activated-sludge process devised for use in the mainland. The addition of nitrogen and phosphorus nutrients was required to increase biomass accumulation and to stabilize the reactors to obtain high removal efficiency from the wastewater of 96.0 and 97.7%, COD and BOD₅, respectively. In France, there have been several attempts to optimize the rate of aerobic treatment of winery wastewater through seeding winery bacteria, pH adjustment and addition of nitrogen and phosphorus nutrients. Their goal was to reach sufficient treatment levels (<500 mg BOD₅/l) within a few days so that the treated effluent could be safely discharged to the municipal treatment system (Morais and Santos, 1995). The catalytic oxidation of *p*-coumaric acid, a compound representative of the polyphenolic fraction typically found in wine distillery, was investigated using Fe²⁺, Cu²⁺, Zn²⁺ and Co²⁺ ions and metal oxide catalysts in suspension. Results showed that catalysts increased the decomposition rate of *p*-coumaric acid while the solution pH controlled the distribution of intermediate compounds (Graham and Weathers, 1997). Vinasse is a serious problem in wastewater treatment. It was determined that 90% COD removal of vinasse purified with mesophilic aerobic/mesophilic anaerobic or thermophilic anaerobic treatment required minimum HRTs varying from 4 to 8 days, respectively. A substrate utilization model was accurate except when HRTs dropped to minimum values (Romero *et al.*, 1996). Resveratrol, a phytoalexin found in grapes and other food products, was purified from grape skin waste and shown to have cancer chemopreventive activity in assays representing three major stages of carcinogenesis. These data suggest that resveratrol, a common ingredient of the human diet, merits investigation as a potential cancer chemopreventive agent in humans (Jang *et al.*, 1998).

Distillery waste

In a comparative study of anaerobic digestion of untreated and previously fermented (with *Penicillium decumbens*) molasses, continuous-stirred tank reactors were used. The observed difference in digestion process could possibly be attributed to interference and inhibition of anaerobic bacteria activity by higher concentrations of phenolic compounds in the untreated wastewater (Jimenez *et al.*, 1997).

Assessment of several alcohol distillery plants treating sugar beet molasses showed that the use of open stream and recycle of spent mash affected wastewater volume up to 25%, the COD load remained practically unchanged with recycling whereas total dissolved solids (TDS) significantly increased. Twelve potentially inhibitory phenolic compounds present in sugar beet molasses distillery wastewater were isolated and identified as follows: six benzoic acids, two cinnamic acids, three phenolic aldehydes and one phenolic alcohol (Graham and Weathers, 1997). A method for precipitation and flocculation of ethanol fermentation wastewater using a combination of various media such as black pulping liquors, lime and polyacrylamide was recently suggested. This promising process yielded water suitable for reuse in ethanol fermentation and residue and is

potentially acceptable for animal feeds and microbial culture media (Morais and Santos, 1995). Several technological options were developed for recycling or treating sugar-processing by-products, including stillage. Studies on anaerobic treatment of various distillery effluents employed full-scale upflow anaerobic sludge blanket (UASB) reactors and highlighted the treatment of effluents from sugar cane based distilleries with COD concentrations of 60 000 to 160 000 mg COD/l (Boudouropoulos and Arvanitoyannis, 2000).

Beverage industry

The problems encountered in the operation of anaerobic filters at several soft drink bottling facilities used for pretreatment include odor, problems of a biological nature with the reactor and problems caused on-site in plant operations. A soft drink wastewater treatment process, consisting of coagulation/flocculation followed by extended aeration, was introduced and fully described. Despite the high level of COD removal provided by the two processes, the system performance was inhibited by variations in hydraulic and organic loading, contamination by petroleum oils and the carry-over of solids from the clarifier to the biological system (Hiddink, 1995). In a recent pretreatment technology review for a soft drink manufacturer, high-pressure reverse osmosis was preferred over the other membrane filtration technologies. Biological pretreatment was rejected after a cost analysis was carried out on pilot testing of various membrane filtration technologies. This process was selected because of its high processing capacity and a 99% BOD removal. Another article focused on bringing a soft drink production facility into regulatory compliance through waste minimization. The latter was accomplished by employing the waste beverage as a feed supplement for a local beef cattle facility (Schulte, 1994).

Fruit and vegetable industry

The agricultural industry waste proves to be an immense reservoir of materials of natural origin. The exploitation of this waste provides natural products of inexpensive starting material like antioxidants. VIORYL SA (Athens, Greece) is a representative example of a Greek company where research is carried out on pressed grape skins from the winery waste and the citrus peel after juice removal. The main features of this approach are: choice of solvent(s), for efficient extraction and recycling, environmentally innocuous as possible and selecting conditions for non-destructive product recovery (Kefalas, 1991). An extensive literature search on disposal and utilization of solid vegetable, fruit and other organic waste was conducted. The study considered the implementation of anaerobic digestion, animal feeding, composting, edible fiber recovering, fermentation, incineration, pyrolysis and soil amendment as options for environmental management systems (EMS) (Walsh *et al.*, 1993). The factors involved in the land application of strong citrus wastewaters were described (Jones and Horvath, 1993). Typical flavonoids, such as hesperidin and naringin, which have pharmacological properties, were extracted from orange, grapefruit and bergamot peels

(el Nawawi, 1995; Calvarano *et al.*, 1996). Both flavonoids were released by extraction of peel with hot water and $\text{Ca}(\text{OH})_2$. The effect of peel maturity and recycling of the extracting liquor led to an increase in yield of both hesperidin and naringin. The highest yield of naringin and hesperidin were 15.2 g/kg and 12 g/2 kg peel, respectively (el Nawawi, 1995).

Three sequencing batch reactors (SBR) pilot plants for treating potato processing wastewaters were operated at various temperatures, in order to study the differences occurring at these temperatures. Although only slight differences in effluent soluble COD concentration related to temperature were reported, nitrification was substantially reduced at low temperatures (12°C). Phosphorus removal significantly dropped at the highest temperature (32°C) (Grant *et al.*, 1994). Utilization of waste mushroom compost as an adsorption medium and as a microorganism source to remediate insecticide rinsate was also investigated. The compost was shown to absorb carbamate pesticides from aqueous solutions and does not have an inhibitory effect within the concentration range of 0–30 mg/l. Another relevant study reported the composting of potato peel waste which, amended with sawdust and urea over a 3- to 4-week period, resulted in a 51% loss in weight and 27% loss in dry matter (Lowe and Buckmaster, 1994). The process selection methodology and analytical problems are associated with phosphorus removal from oil seed and wastewater from vegetable production. The performance of an anaerobic upflow blanket type reactor for the treatment of olive oil production wastewater was evaluated (Ozturk *et al.*, 1992).

Meat and poultry

The biosolids produced by dissolved air flotation (DAF) wastewater treatment systems at meat and poultry processing plants constitute a crucial disposal problem and handling of these materials was addressed in several papers. Carr (1992) recently presented an overview of the aerobic composting process comprising comparison of various novel systems for handling DAF biosolids and for dewatering. The stabilization of offal and dissolved air flotation sludges using lactic acid was evaluated as well. The study focused on measuring pH, ammonia, protein, fat and bacterial pathogens in an effort to assess sludge quality. A comprehensive study of the foaming and bulking problems in poultry processing wastewater activated sludge system was conducted. Among the investigated factors were the process type, the food microorganisms (F:M) ratio, the dissolved oxygen levels, the liquid operating temperature, the changes of production rate and the inlet/outlet design of the aeration cell (Walsh *et al.*, 1995). The source of odors from several already discussed control techniques, including combustion in boilers, wet scrubbers and biofilters was recently reviewed. The technical and economic details of biofilters applications were presented (Prokop, 1992).

Agricultural waste

Water pollution, particularly by pesticides and herbicides, has been recognized as a very serious problem since the 1970s. Industrial compounds and product contaminants such

as polychlorinated biphenyls (PCBs), polychlorinated dibenzo-*p*-dioxins (PCDDs) and polychlorinated dibenzofurans (PCDFs) were found to be present in a large fraction of tested humans (Price and Welch, 1972; Sielken *et al.*, 1987). As was the case with DDT and other chlorinated insecticides, background levels of PCBs, PCDDs and PCDFs occur in high portions in tested humans. These lipophilic compounds, occasionally suspect carcinogens and abundant in fatty foods, could easily be introduced into human beings when these compounds abound in the terrestrial environment (Fries, 1991). Of great concern is the extent to which pesticides reach rivers and lakes, because this may have impact both on aquatic life and humans if contamination extends to drinking waters. These concerns were addressed by the EC Drinking Water Directive, which stipulates a maximum concentration of any pesticide in potable waters of 0–1 µg/l. Although the toxicity of different pesticides to humans varies greatly, there is a general lack of epidemiological data regarding the pesticides effect on human health, probably because research tends to be reactive, rather than proactive (Boudouropoulos and Arvanitoyannis, 2000).

The effects of pesticide drift on flora and fauna were reported in English Nature (Anonymous, 1997). Despite the reported measurable short-term impact on wildlife, the time scale and long-term effects continue to be uncertain. Research into nitrogen fertilizer used in agriculture highlighted three main areas of potential environmental impact: water contamination, gaseous losses and effects on humans. The secondary economic costs, notably related to the water industry, are also significant, although research is starting to show how good management practices can reduce losses (Skinner *et al.*, 1997). Herbicide contamination of shallow groundwater beneath claypan soils has been the subject of several investigations. Spatial variability was determined to be larger than the effects of atrazine and arachlor application rates. In samples taken from approximately 75 monitoring wells, atrazine and arachlor were detected in 7.2 and 0.4%, respectively. No significant differences in arachlor, atrazine and nitrate concentrations were detected between pre- and post-flood distributions in alluvial aquifers in the USA (Chung *et al.*, 1998).

Compost from agricultural and other waste and granular activated carbon biofilters operated at a wastewater treatment plant simultaneously removed low concentrations of H₂S and VOCs. Microorganisms on both media demonstrated an increase in microbial densities, varying degrees of environmental stress and predominance of gram-negative bacteria. Lowering pH had little effect on compound removal, which was >99% for the H₂S and >70% for the oxygenated and aromatic hydrocarbons (Webster *et al.*, 1997). A pilot-scale composting of chlorophenol-contaminated soil was set up to compare chlorophenol degradation by two different inoculants, straw compost and bioremediated soil, with that of indigenous soil microbes. The biodegradation was found to be highly efficient, fast and, most importantly, independent of the inocula type (Laine and Jorgensen, 1997).

Gergova *et al.* (1994) studied the production of activated carbon from agricultural residues, including apricot and cherry stones, almond shells and grape seeds. The study involved a low temperature process and it was concluded that the characteristics of the activated carbon depend upon the feedstock composition and structure. Mazza (1995) reported the flow diagram for resource recovery from grape pomace. Another investigation topic was nitrification and denitrification in an activated sludge system

for wastewater from settled sow manure with molasses addition as a supplemental carbon source. Full denitrification proved impossible with supernatant from manure as the only carbon source. When nitrifying and denitrifying conditions were improved, only small amounts of nitrogen oxide were found to be present (Marr and Facey, 1995). Olive oil production is of great importance especially for Mediterranean countries because of its high consumption rate. Milling of olive paste during olive oil production is accompanied by continuous washing with water malaxation leading to considerable wastewater quantities, which are discarded. A study disclosed that the wastewater extracts have powerful antioxidant action due to the presence of natural antioxidants. If the latter were successfully recovered and could show that the waste from olive oil production had a powerful anticarcinogenic activity, it would be a promising non-expensive source of antioxidants (Visioli *et al.*, 1995).

Effects of pollution on organisms

Many articles reported on the effects of a wide variety of pollutant forms, including individual complex chemicals and metals to freshwater and seawater aquatic organisms. In a rapid bioassay, 96 cell culture plates for screening herbicides and other phytotoxins for selective toxicity toward cyanobacteria were developed. *Oscillatoria cf. chalybea* and *Selenastrum capricornutum* were chosen as representatives of cyanobacteria (Cyanophyta) and green algae (Chlorophyta), respectively (Schrader *et al.*, 1997).

A number of ectomycorrhizal fungi, from sites uncontaminated by toxic metals, were analyzed to determine their sensitivity to Cd^{2+} , Pb^{2+} , Zn^{2+} and Sb^{3+} . Significant interspecific variation in sensitivity to Cd^{2+} and Zn^{2+} was recorded, whereas Pb^{2+} and Sb^{3+} , individually, had little effect. The presence of Pb^{2+} and Sb^{3+} in these media did, however, ameliorate Cd^{2+} and Zn^{2+} toxicity in some cases. Among various heavy metals, mercury, cadmium and cobalt were shown to be the most toxic to selected strains of wood-rotting basidiomycetes (Baldrian and Gabriel, 1997). Among 75 strains of iron-oxidizing bacteria obtained from natural environments, only one strain, *Thiobacillus ferrooxidans* Funis 2-1, grew on Fe^{2+} -medium with 1.25 mM of sodium molybdate (Mo^{6+}). Further studies revealed the inhibition site of molybdenum for the iron-oxidase enzyme system and the mechanism of molybdenum resistance in Funis 2-1 cells (Yong *et al.*, 1997). Sampling of faunal species near a lead smelter in South Australia revealed no consistent patterns in numbers of taxa among study areas and times. In fact, it was shown that *Heteromastus filiformis*, *Capitella capitata*, *Glycera americana* and the crustacean *Tanais dulongii* were abundant at intertidal sites with high metal concentration in the sediments (Reish *et al.*, 1997).

There is only limited available evidence indicating that chlorinated compounds occurring in the environment had an adverse effect on earthworm populations. Applications of DDT at rates exceeding 100 ppm had no effect on earthworm survival and concentrations of DDT or dieldrin as high as 64 ppm did not affect the survival of *L. terrestris* and *A. caliginosa* in laboratory studies. It was shown that earthworm activity was more or less normal in the area around Seveso, most highly contaminated

by TCDD (dioxin), but there may have been an effect on the ratios of *A. caliginosa* to *A. rosea*, which were the most abundant species (Fries, 1991).

Birds have provided the most notable examples of adverse and disastrous effects of organic contaminants on terrestrial wildlife. The effects of chlorinated hydrocarbons on eggshell thickness were further confirmed in laboratory studies. The frequency and severity of the reproductive problems were greatest for aquatic predators followed by terrestrial predators, insectivores and herbivores. Improper disposal of contaminated waste oils has caused acute poisonings of cattle and horses by PCBs and PCDD (Beeson *et al.*, 1997). The carcinogenic dioxins have entered the life of European citizens and managed to undermine the current food safety system in zero time. It is believed that the European Union (EU) was aware of at least some of the occurring safety problems but was reluctant to enforce stricter regulation because of the ensuing higher production cost. However, prior to dioxin detection, extremely high hormone residues had been measured in meat carcasses originating from the USA (Papanidis, 1999). Kittiwakes from a colony within the area oiled by the crude oil spill in the Shetland Islands had relatively good breeding success and foraging activity compared with colonies in non-oiled areas. However, birds from the oiled area were anemic and the adult return rate and male fidelity were low (Reish *et al.*, 1998). Due to large spatial and temporal variability, ichthyoplankton surveys both at outfall and non-outfall failed to reveal any consistent differences in taxa or abundances of fish due to treatment either at the surface or at a 20-m depth. However, a mixture of primary and secondary wastewater sludge produced significant toxic effects, even at 0.1% dilution, to herring embryo vitality, hatching mortality, post-hatch larval survival and larval feeding under laboratory conditions. Toxic effects were confined to the discharge point. Chlorine, commonly used to disinfect wastewater and power plant discharges, was shown to be toxic to various stages of anchovy eggs and larvae at concentrations well below the recommended treatment doses (0.1–0.2 versus 3.0 ppm, respectively) (Rosales-Casian, 1992).

The frequency and mechanism by which organic compounds are introduced into the environment have an important impact on food products. Combustion sources, such as municipal waste incinerators and automobiles, have been identified as the main sources of low-level dioxin and furan environmental contamination (Skinner *et al.*, 1997). Bouchard *et al.* (1992) described the various natural and synthetic sources of nitrate contamination of groundwater, the sources of human exposure to nitrate and the potential health effects and the challenge to manage groundwater protection from nitrate. The relationship between nitrate levels in private and public sources of drinking water and gastric cancer mortality in Wisconsin (USA) was investigated in a case-control study. Death resulting from gastric cancer could not be significantly associated with exposure to nitrate in drinking-water sources (Boudouropoulos and Arvanitoyannis, 2000).

Glass, chemicals and other products

New technology in the field of glass production lowered the gas release of substances such as NO_x and particulates, and parameters such as BOD, but there is still room for

further improvement. Although attaining zero pollution is a virtually impossible target, striving to improve the environment is a constant goal (Slater, 1997).

Industry provides a selection of techniques and pollution arrestment plans available for meeting current or even future (most probably stricter) legal requirements. As to the recent EU legislation, the Integrated Pollution Prevention and Control (IPPC) reported in a British newspaper (became UK law in October 1999), that consideration should also be given to the possible reversal of enforcement from local authority to the HM Inspectorate of Pollution (Environmental Protection Act, 1990). The use of toxic heavy metals is subjected to severe restrictions in order to reduce their effects on the environment, to guarantee health and safety at the workplace and, in general, to minimize their mean daily intake by individuals (Guadagnino, 1996).

The impact of the Clean Water Act (CWA) on industry was reviewed from the historical perspective of the National Pollutant Discharge Elimination System (Kobylnski and Hunter, 1992). Gemar (1991) suggested how industries could comply with the new pretreatment regulations for discharge to a publicly owned treatment works (POTW). These regulations focused on both mass and concentration of specific compounds discharged to the municipal sewer.

A waste management plan for the chemical and petrochemical industry in Brazil included regional management of hazardous wastes, strict control of landfill content and pretreatment facilities. The improvement of groundwater quality at a major industrial complex was initiated in three phases: baseline data collection, establishment of monitoring programs and recommendations for new management practices. Increase in polluted areas due to poor landfill operations at a chemical industry in the Netherlands was the main factor that led to a program of waste management/minimization for this facility. A recovery process for nitrophenols addressing possible thermal instabilities was developed to meet the limits set on phenolic compounds sent for biological waste treatment (Teixeira and Balassiano, 1991). Biological treatment is a very important process for removing dissolved organics from refinery wastewater. Microbial cultures were studied to compare the ability to biotreat refinery spent sulfidic caustic from a refinery. Both cultures, *Thiobacillus denitrificans* strain F and an acclimated culture enriched from an activated sludge treatment system at a refinery, proved to be capable of complete oxidation of caustic sulfides to sulfates at specific activities of 1.0–1.3 mmol sulfide/h · g mixed liquor suspended solids (Kolhatkar and Sublette, 1996).

Anaerobic treatment of petrochemical wastewater has become a very popular topic over the past few years. Cheng *et al.* (1997) conducted a pilot study of UASB process treating wastewater from purified terephthalic acid (PTA) manufacturing. One of the major constituents, *p*-toluic acid, in PTA wastewater restricted the biodegradation. Phenolic compounds are abundant both in natural products and industrial and municipal waters (Gerard *et al.*, 1995). Their presence might prove to be harmful, especially if they are subjected to chlorination which results in chlorinated phenolic compounds, highly toxic even at ppb levels. The phenolic compounds contained in this wastewater are used as feedstock for the production of polymers, drugs and dyes despite their poor environmental performance. Therefore, an extraction of phenols from water samples by liquid–solid phase extraction is employed (Pissolato *et al.*, 1996).

Strict emission legislation has currently rendered many existing emission-control measures inadequate. The effect of automotive catalysts to offset the incomplete combustion in automobile engines in response to the Clean Air Act of 1970 was reviewed. Measurements of emission data of unburned hydrocarbons and carbon monoxide at both upstream and downstream sides of a catalyst converter showed that significant reductions in emissions could be obtained with appropriate ignition-control strategies (Zhu *et al.*, 1996).

Environmental attitudes and politics

The economic growth of modern industrialized society has been mainly based (80%) on utilization of energy stored in fossil fuels. Although humans have learned to exploit them rather efficiently, consumption of fossil fuels has become a tantalizing force because of emissions, spills, leaks, strip mining and carbon dioxide accumulation which leads to highly dangerous and threatening situations in terms of global warming (greenhouse effect), risking sea levels and earthquakes (Kordesch and Simander, 1995). By 1990, public concern for the environment in the USA had reached unprecedented levels. In one of the most thorough and comprehensive reviews of American public opinion toward the environment, it was concluded that, after a decline in environmental concern in the 1970s, there has been a significant and steady increase in public awareness of environmental problems (Steel, 1996).

Modern environmental policy is discussed largely in terms of assessing the usefulness to humans of preserving services provided by the environmental systems. Environmental concern is often expressed by rejection of directly anthropocentric and economic calculations (Spash, 1997). The pollution abatement schemes can be successfully implemented only when the causes of pollution have been properly identified. Pollution problems, arising from 'free rider' behavior, result in high costs of negotiation among users of a common resource. These costs are occasionally due to misspecification and/or to non-enforceability of property rights on the use of common resources. Alternatively, when well-defined property rights exist and their enforceability is possible, the presence of technological non-convexities makes impossible the establishment of competitive markets for pollution emission rights (Bellás and Skourtos, 1996).

Solid waste audits, aimed at the identification of opportunities for waste reduction, reuse or recycling, were described by the 'Go Green team', which also identified these opportunities in the original 1995 audit, forming the basis for the waste diversion initiatives. In particular, the 1995 initiatives were very successful in increasing the reuse and recycling activities. The next audit, however, should include protocols for characterizing the material in the mixed waste bags (Dowie *et al.*, 1998). In effective networks, information and research, in conjunction with grass-roots involvement are to be pursued, since a more professional approach has to be endorsed through government support, appropriate funding and proper staffing. Indeed, it is argued that lack of formal government recognition and endorsement of the forum approach inhibits their credibility, since potential members and staff time are not properly prioritized (Scott, 1998).

Although various factors may lie behind the recent upsurge of interest in green taxes, the predominant factor might be disenchantment with efficiency and effectiveness of the direct regulation approach to environmental policy. Nevertheless, wider public finance employment and social concerns contributed to a 'build up' of pressure for change. Instruments such as charges, permits and subsidies score well on efficiency grounds, but they are more problematic in terms of their institutional requirements and their political feasibility. On the other hand, product prohibitions, technology specifications and information provision, for example, face relatively little political resistance and have no institutional demands, but are relatively inefficient because of the high costs of involved meetings and ambient standards (Turner *et al.*, 1998).

Several industrialized countries such as the USA, the UK and France have long realized the need for environmental impact assessment (EIA). As a result, they have adopted formal EIA principles and practices for various activities including the construction of highways (Glasson *et al.*, 1999) and for the mining and industrial sector. Current trends in environmental degradation suggest that if the rate at which the environment is depleted continues, the world will cease to be a viable place. Reports about global warming and the depletion of the ozone layers suggest the need for urgent action to avoid an imminent catastrophe (Boudouropoulos and Arvanitoyannis, 1999).

Progress in alternative energy

Solar energy

Energy from the sun is vital for the living world. It is harnessed by plants, which use it to turn water and carbon dioxide into complex high energy molecules. More than 10^{17} kJ of energy from sunlight is captured and used by photosynthetic organisms (Durrant, 1998). Solar electric power was developed to overcome a specific power problem within the frame of NASA space programs of the 1960s. Like many other space technologies, solar radiation was later on adapted and used on Earth, but initially used in remote areas where power was desirable but difficult to provide by other means.

The potential financial savings made by generating solar electricity depend on cost of national power, which varies considerably, and the price paid by the operator for the exported solar power. Since solar power generates direct current electricity which has to be converted to alternating current to interface with the grid, there are additional infrastructural and familiarization barriers to overcome with the participants therein (architects, builders, electricians and electricity operators). These are being rapidly addressed as international experience develops (Wolfe, 1998). Although this is still a relatively expensive technology, the cost for solar power is gradually decreasing and the market is expanding. New lower cost technologies are currently commercialized and, in fact, the World Energy Council predicts substantially greater sales by 2025. With the issues of climate change and environmental depletion increasingly at the forefront of the political agenda, the prospects for this technology are extremely promising (Hammonds, 1998).

Aeolian energy and air pollution

Over 700 MW of wind energy has been produced worldwide, making it the fastest growing energy technology. The reason for this rapid growth in wind energy can be traced back to the oil crisis of the 1970s, but more recent stimuli have included the urgent need for electricity in third world countries and the need to find non-polluting energy sources. Wind energy is now a viable option for generating electricity because it is technically proven, enjoys public support, has huge resources and is rapidly becoming cost-competitive with the 'conventional' sources of electricity generation. There are good prospects for future cost reduction and improvements in performance. 'Economic optimization' in turn, depends on a proper understanding of the complex nature of wind turbine loadings and is reflected in further work on dynamics and fatigue (Milborrow, 1998).

A future of melting ice caps and changing climates has been predicted as a result of global warming due to the 'greenhouse effect'. Essentially linked to the emissions of greenhouse gases into the atmosphere (most notably carbon dioxide), this disruption in the Earth's ecosystem is causing great concern. It is widely accepted that the greenhouse effect, caused by rises in atmospheric CO₂ levels, will result in extensive warming of the Earth's surface with potentially disastrous environmental impact (Ormerod, 1998).

There are four main options for capturing carbon dioxide: adsorption, absorption, cryogenics and membrane systems. Gas adsorption commonly involves the utilization of molecular sieves which, however, require the release of absorbed gas after its capture. Varying the process to release the gas is preferable to altering the temperature because the absorber can start re-functioning much faster. Limited capacity and poor sensitivity makes this method unattractive for CO₂ capture from the conventional (PF = pulverized fuel and NGCC = natural gas fired combined cycle) generation process. Several solvents can be applied to each type of power plant to achieve physical and chemical absorption. Cryogenic processes are only worth considering where there is a high concentration of CO₂ in the gas, as may be the case in future integrated gasification combined cycle (IGCC) designs, or from CO₂ recycle systems. Cryogenic processes have the advantage of producing liquid CO₂ ready for transportation via pipelines. Although they are commercially used, the membranes need further development and their cost has to come down before they can be more widely used for capturing CO₂ (Boudouropoulos and Arvanitoyannis, 2000).

Scientific responses to climate change deserve serious consideration as ways of limiting greenhouse gases while continuing to satisfy human aspirations for improved life quality. If CO₂ emissions have to be substantially reduced, capture and storage of CO₂ is a presupposition. Such technologies have only recently attracted scientific interest and there are currently available practical examples of capture and storage techniques around the world (Riemer, 1998).

Hydropower, geothermal, fuel cell systems and other alternative energies

Hydropower is a clean, non-polluting, reliable, long-lasting and renewable energy source. It produces nearly a fifth of the world's electricity, making it far and away the

most productive renewable source. Wind, biomass energy and hydropower are the most utilized renewable sources, accounting for more than 90% of overall electricity generation. Based on the potential of hydropower and the move towards reducing power plant emissions that contribute to global warming, it appears that hydropower can be one of the major factors in building up a sustainable worldwide economic growth well into the future (Hunt and Hunt, 1998).

Geothermal energy, heat from the Earth, is available at many sites across the world and is only being partially used to replace conventional fuels. The enormous potential of this clean, reliable energy source is only now being realized with increasing construction of electricity generating stations, district heating systems, food-processing plants and greenhouses throughout the world. In the years ahead, when environmentally friendly energy sources become even more important, geothermal energy is expected to help fill our needs. Although it is not a final solution for the world's clean energy needs, it constitutes a significant contributor and has great potential for expansion in the future. Advanced research and technology development will eventually enable mankind to use the enormous amount of geothermal heat contained in rocks at any depth and not just in volcanic areas. When this stage of development is reached, geothermal energy might well supply as much as 25–50% of the world's electrical and heating needs (Wright, 1998).

A fuel cell is an electrochemical device which can continuously convert the energy from a chemical reaction and an oxidant fuel to electrical energy by a process involving an electrode–electrolyte system. Fuel cells are characterized by high efficiency and lower emission levels than those prescribed by the strictest environmental standards. Fuel cell systems can be classified according to their working temperature/pressure as high-, medium- and low-temperature/pressure systems. Another categorization may be based on the nature of employed fuels and oxidants: gaseous (hydrogen, ammonia), liquid (alcohols, hydrocarbons) and solids (coal). The most important features of fuel cell systems in terms of advantages could be summarized as follows:

- 1 savings in fossil fuels due to high energy conversion/good load characteristics
- 2 low pollution level/noise level/maintenance costs
- 3 ability to use low cost fuels with high temperature systems and increased efficiency.

However, there are also disadvantages consisting of the initial high cost of catalysts, membranes and accessories, high fuel weight, electrode degradation in conjunction with complete carbon dioxide removal and infrastructure weaknesses for hydrogen transportation and distribution (Kordesch and Simander, 1995).

Although harvesting waste may sound like a strange idea, it is one of the safest ways for cleaning up contaminated land. Using plants that preferentially absorb toxic metals from the soil and then simply harvesting and disposing them could revitalize land contaminated with metals both inexpensively and in an environmentally friendly way. Many practical and research challenges remain to be met prior to bio- and phyto-remediation application on a large scale to decontaminate metal-polluted soils. However, this 'green' approach using hyperaccumulator plants to decontaminate polluted sites is considered to have considerable potential in the quest to safeguard soil fertility, one of the world's most precious natural assets (McGrath *et al.*, 1998).

Environmental impact assessment

Cost-benefit analysis (CBA) is a methodology which aims to select projects and policies which are efficient in terms of resource use. As the name suggests, it is, in principle, extremely simple. All the positive and negative effects of a proposed project or policy are valued in monetary terms, providing a list of benefits and costs. If benefits are seen to outweigh costs, then the proposed plan represents a potential gain in terms of social welfare. Although CBA is widely practised and accepted, it has also been strongly criticized from perspectives outside economics, particularly the environmental and social spheres. Criticisms generally revolve around:

- 1 the uncertainty
- 2 the accuracy and acceptability of monetary valuations of impacts
- 3 the distribution of costs and benefits among the population
- 4 the practice of discounting the future in estimating total costs and benefits
- 5 the treatment of irreversibility in development decisions
- 6 the institutional impartiality of the CBA process
- 7 the lack of a sustainability criterion in cost-benefit decision-making.

The various stages of the cost-benefit analysis methodology are the following:

- 1 project definition
- 2 classification of impacts:
 - i timing impacts
 - ii irrelevant impacts
 - iii estimation of impacts
 - iv additionality of with-minus-without
- 3 conversion into monetary terms:
 - i adjustments for inflation
 - ii adjustments for shadow prices
- 4 discounting:
 - i pure time preference and opportunity costs
 - ii productivity of capital
- 5 project assessment under the net present value (NPV) and internal rate of return (IRR) tests:
 - i net present value
 - ii distributional assessments
- 6 sensitivity analysis (Edwards-Jones *et al.*, 2000).

The high uncertainty about the estimations of the external environmental costs is one of the main reasons why the classic cost-benefit analysis is not considered very useful to support environmental policies. The literature on external costs provides several studies accounting for a large part of uncertainty by means of appropriate statistical and sensitive analysis. By elaborating these results, the analysis described seems to

support the conclusion that centralized supply, and especially the completely electric solution (based on the reversible electric heat pump), is still preferable to natural gas-fired combined heat and power (CHP) distributed generation. This is not a definitive conclusion but a useful (scientific based) contribution for policy decisions under the state of the art. The European Commission is indeed advocating combined heat and power distributed generation (CHP DG) as a contribution to greenhouse gas (GHG) emission reduction as well as the recent European Directive on the promotion of cogeneration is very favorable to micro-cogeneration and small CHP plants, on the basis of their supposed environmental benefits (Gulli, 2006).

Environmental Impact Assessment (EIA) is the process of predicting the impact of a planned activity, usually a project or policy, on the environment before that project/policy is initiated. It is not an end in itself, rather the purpose of any EIA is to aid the development decision. A good EIA ensures that decision-makers have available as good information as possible when considering projects. The second layer within the EIA is concerned with the process and structure of the EIA, while the third layer within the EIA is concerned with the actual activities that take place within the EIA structure (Glasson *et al.*, 1999; Edwards-Jones *et al.*, 2000). The examples of computer models which could be used to predict impacts as part of environmental impact assessments are given in Table 1.1.

The United Nations Economic commission for Europe (1991) has an altogether more succinct and pithy definition: 'an assessment of the impact of a planned activity on the environment'. EIA is a systematic process that examines the environmental consequences of development actions, in advance. The emphasis, compared with many other mechanisms for environmental protection, is on prevention. The process involves a number of steps, as outlined in Figure 1.1. EIA is normally wider in scope and less quantitative than other techniques, such as cost-benefit analysis. The EIA process has the potential, not always taken up, to be a basis for negotiation between the developer, public interest groups and the planning regulator. The environmental impacts of a project are those resultant changes in environmental parameters, in space and time, compared with what would have happened had the project not been undertaken. The parameters may be any of the type of environmental receptors noted previously: air quality, water quality, noise, levels of local unemployment and crime. Types of impact are physical and socio-economic, direct and indirect, short-run and long-run, local and strategic, adverse and beneficial, reversible and irreversible, quantitative and qualitative, actual and perceived.

EIA was first formally established in the USA in 1969 and has since spread, in various forms, to most other countries. A 1985 European Community Directive on EIA (Directive 85/337) introduced broadly uniform requirements for EIA to all EU Member States and significantly affected the development of EIA in the UK. The object of prediction is to identify the magnitude and other dimensions of identified change in the environment with a project or action, in comparison with the situation without that project or action. Prediction involves the identification of potential change in indicators of such environment receptors. Scoping will have identified the broad categories of impact in relation to the project under consideration. If a particular environmental indicator (e.g. SO₂ levels in the air) revealed a gradually increasing

Table 1.1 Examples of computer models which could be used to predict impacts as part of environmental impact assessments

Model	Purpose
Crop estimation through resource and environment synthesis (CERES) – maize	To test quickly and easily a variety of different fertilization and irrigation schedules to maximize maize (corn) production from a given piece of land
Atmospheric greenhouse model (AGM)	To analyze the consequences for the global climate of various scenarios regarding the production of carbon dioxide from fossil fuel combustion
Range, livestock and wildlife model	To help decision-makers understand and evaluate policy alternatives for rangeland management
Enhanced stream water quality model	To provide tools for water quality planning by simulating the behavior of the hydrologic and water quality components of a branching stream system or lake under the impact of a wide range of pollutants
Waterborne toxic risk assessment model	To estimate the risks of adverse human health effects from substances emitted into the air, surface water, soil and groundwater from a source such as a coal-fired power plant

Adapted from Edwards-Jones *et al.*, 2000

problem in an area, irrespective of the project or action (e.g. a power station), this should be predicted forwards as the baseline for this particular indicator (Glasson *et al.*, 1999). Assessment of effects (including direct and indirect, secondary, cumulative, short-, medium- and long-term, permanent and temporary, positive and negative effects) having an impact on:

- 1 human beings, buildings and man-made features
- 2 flora, fauna and geology
- 3 land
- 4 water
- 5 air and climate
- 6 other indirect and secondary effects associated with the project (DOE, 1989).

Although methods and models for prediction can be classified in many ways, they are not mutually exclusive. In terms of scope, all methods are partial in their coverage of impacts, but some seek to be more holistic than others. Partial methods may be classified according to type of project (e.g. retail impact assessment) and type of impacts (e.g. wider economic impacts). Some may be extrapolative, others may be more normative. Normative approaches work backwards from desired outcomes to assess whether a project, in its environmental context, is adequate to achieve them.

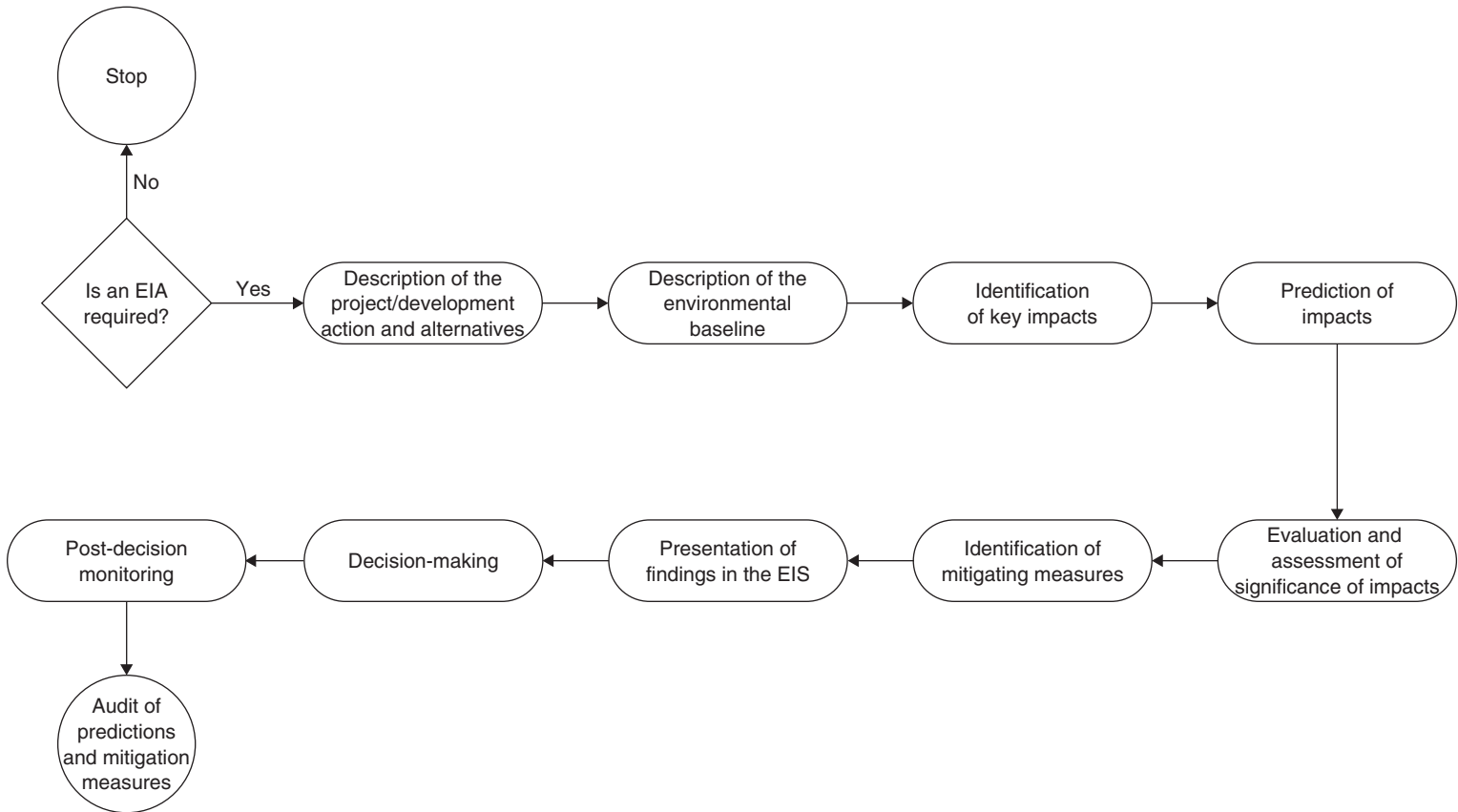

Figure 1.1 Important steps in the EIA process

Methods can also be classified according to their form, as the following six types of model illustrate:

- 1 Mechanistic or mathematical models: describe cause-effect relationships in the form of flow charts or mathematical functions. Mathematical models can also be divided into deterministic and stochastic models. Deterministic models, like the gravity model, depend on fixed relationships. In contrast, a stochastic model is probabilistic.
- 2 Mass balance models: establish a mass balance equation for given 'compartments'. Inputs to the compartment could be, for instance, water, energy, food or chemicals; outputs could be outflowing water, wastes, or diffusion to another compartment.
- 3 Statistical models: use statistical techniques such as regression or principal components analysis to describe the relationship between data, to test hypotheses or to extrapolate data.
- 4 Physical, image or architectural models: are illustrative or scale models that replicate some element of the project-environment interaction.
- 5 Field and laboratory experimental methods: use existing data inventories, often supplemented by special surveys, to predict impacts on receptors.
- 6 Analogue models: make predictions based on analogous situations. They include comparing the impacts of a proposed development with a similar existing development (Glasson *et al.*, 1999).

The Environmental Impact Statement (EIS), sometimes known as the environmental effects statement (EES), the environmental statement (ES) or as the environmental impact assessment (EIA), depending upon country, is a document, prepared by a component, describing a proposed development, or activity (or a plan, or program) and disclosing the possible, probable, or certain effects of that proposal on the environment. An EIS should be comprehensive in its treatment of the subject matter, objective in its approach and should be sufficiently specific for a reasonably intelligent mind to examine the potential environmental consequences, good and bad, of carrying out, or not carrying out, that proposal.

An EIS usually includes the following: a full description of the proposed project, or activity; a statement of the objectives of the proposal; an adequate description of the existing environment likely to be affected by the proposal; the identification and analysis of the likely environmental interactions between the proposal and the environment; the justification of the proposal; economic, social and environmental considerations; the measures to be taken with the proposal for the protection of the environment and an assessment of the likely effects of those measures; any feasible alternatives to the proposal; and the consequences of not carrying out the proposal for the component, community, region and state. The characteristics of a good EIS, EES or ES are:

- 1 a summary of the EIS
- 2 acronyms and initials should be defined
- 3 the list of contents
- 4 the authors of the EIS should be clearly identified

- 5 a brief outline of the history of the proposed development
- 6 a full description of the proposed project or activity, its objectives and geographical boundaries
- 7 a full description of the existing environment likely to be affected by the proposal; the baseline conditions; deficiencies in information; data sources; the proximity of people, other enterprises
- 8 the alternative locations considered or alternative processes
- 9 the justification of the proposal in terms of economic, social and environmental considerations
- 10 the planning framework, relevant statutory planning instruments, zoning
- 11 the identification and analysis of the likely environmental interactions
- 12 the measures to be taken with the proposal for the protection of the environment and an assessment of their likely effectiveness
- 13 the implications for public infrastructure such as housing, schools, hospitals, water supply, garbage removal, sewerage, electricity, roads, recreational facilities, fire, police, emergency services
- 14 any cumulative effects from similar enterprises should be considered
- 15 proposals for annual reporting to the decision-making body on the implementation and environmental auditing
- 16 the contribution to sustainable development.

Structure of an EIA report is (Gilpin, 1995):

- 1 letter of transmittal to the decision-making body or person
- 2 recommendation
- 3 main findings
- 4 background history
- 5 proposal and EIS
- 6 the issues:
 - a) environmental
 - b) economic
 - c) social
- 7 mitigation measures
- 8 planning context
- 9 appendices:
 - a) list of submissions from the public
 - b) location and site boundaries
 - c) layout of buildings
 - d) transport network
 - e) visual assessment
 - f) air and water quality
 - g) noise, equipment and traffic
 - h) industrial wastes
 - i) alternatives
 - j) energy considerations

- k) risks and hazards
- l) emergency arrangements
- m) rehabilitation.

The direct compliance costs of the assessment process do not appear to have proved a significant problem for large companies, especially if the EA is integrated with feasibility studies. Usually direct costs are less than 1% of total project costs. In some instances this involves planning 5 to 10 years ahead, or even longer in the case of electricity generation or other specific requirements. However, unexpected problems and delays might arise which could not have been anticipated. These delays could arise from:

- 1 a lack of coordination
- 2 conflicting demands between agencies
- 3 the failure of agencies and governments to observe time limits
- 4 an unexpectedly large volume of public opposition
- 5 parliamentary opposition not reasonably anticipated
- 6 significant deficiencies.

These indirect costs can be considerable, amounting to about 10% of total project costs. They are particularly onerous in the case of a large electricity generating system and transmission network. Typically, pollution control costs as a percentage of total plant and equipment costs for: iron and steel industry, 20%; non-ferrous metals, 12%; electricity generating plant, 11%. A most effective tool for improving the process is the audit. Its primary purpose is to ensure that the development has taken place under the terms and conditions imposed by the initial EIA process and its associated development consent or planning approval (Gilpin, 1995).

A UNECE task force (1990) serves the following purposes: to monitor compliance with the agreed conditions, to review predicted environmental impacts, to modify the activity or develop mitigation measures in case of unpredicted harmful effects and to review the effectiveness of environmental management. A preliminary plan for auditing should be prepared during the EIA process and fully developed when a favorable decision is made and it is shown in Figure 1.2.

During recent decades, there have been notable changes in the global and European climate. Temperatures are rising, precipitation in many parts of Europe is changing and weather extremes show an increasing frequency in some regions (IPCC, 2001). According to the UN Intergovernmental Panel on Climate Change (IPCC), 'there is new and stronger evidence that most of the warming observed over the last 50 years is attributable to human activities, in particular to the emission of greenhouse gases' (IPCC, 2001).

Atmospheric indicators show that the concentration of carbon dioxide (CO₂) in the lower atmosphere increased from its pre-industrial concentration of 280 ppm (parts per million) to its 2003 concentration of 375 ppm. This is the highest level in the last 500 000 years. The impacts of climate change on the marine environment are covered in this report by assessing the rise in sea level, the sea surface temperature and changes in the marine growing season and species composition. Climate change

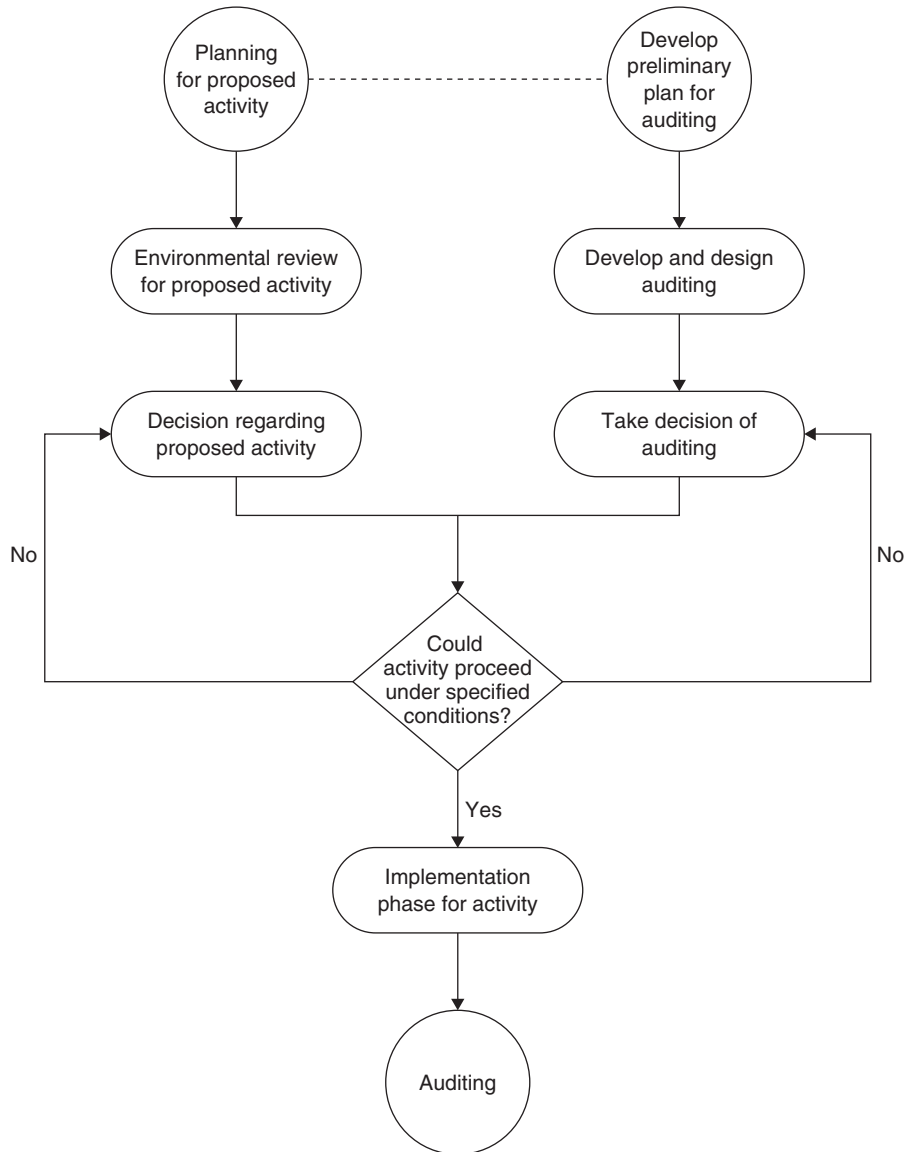

Figure 1.2 The auditing framework linked to the EIA process (adapted from UNECE, 1990)

affects agriculture in many ways. Increasing atmospheric CO₂ and rising temperatures may allow earlier sowing dates, enhance crop growth and increase potential crop yield. Extreme weather events cause damage to industry, infrastructure and private households. In Europe, a large number of all catastrophic events since 1980 are attributable to weather and climate extremes: foods, storms and droughts/heatwaves. Economic losses resulting from weather and climate related events have increased significantly during the past 20 years (http://reports.eea.europa.eu/climate_report_2_2004/en/impacts_of_europes_changing_climate.pdf). The summary of trends and projections of indicators is shown in Table 1.2.

Table 1.2 Summary of trends and projections of indicators

Indicators	Key messages
<i>Atmosphere and climate</i>	
Greenhouse gas concentrations	<ul style="list-style-type: none"> ● Due to human activities, the concentration of carbon dioxide (CO₂), the main greenhouse gas, has increased by 34% compared with pre-industrial levels, with an accelerated rise since 1950 ● To achieve the EU long-term objective of limiting global temperature rise to 2°C, global emissions of greenhouse gases need to be reduced substantially from 1990 levels
Global and European air temperature	<ul style="list-style-type: none"> ● The global average temperature has increased by 0.7 ± 0.2°C over the past 100 years. The 1990s were the warmest decade in the observational record; 1998 was the warmest year, followed by 2002 and 2003
European precipitation	<ul style="list-style-type: none"> ● Annual precipitation trends in Europe for the period 1900–2000 show a contrasting picture between northern Europe (10–40% wetter) and southern Europe (up to 20% drier). Changes have been greatest in winter in most parts of Europe
Temperature and precipitation extremes	<ul style="list-style-type: none"> ● In the past 100 years the number of cold and frost days has decreased in most parts of Europe, whereas the number of days with temperatures above 25°C (summer days) and of heatwaves has increased
<i>Glaciers, snow and ice</i>	
Glaciers	<ul style="list-style-type: none"> ● Glaciers in eight out of the nine glacier European regions are in retreat, which is consistent with the global trend ● From 1850 to 1980, glaciers in the European Alps lost approximately one third of their area and one half of their mass. Since 1980, another 20–30% of the remaining ice has been lost ● By 2050, about 75% of the glaciers in the Swiss Alps are likely to have disappeared
<i>Marine systems</i>	
Rise in sea level	<ul style="list-style-type: none"> ● The projected rate of sea level rise between 1990 and 2100 is 2.2 to 4.4 times higher than the rate in the 20th century and sea level is projected to continue to rise for centuries
Sea surface temperature	<ul style="list-style-type: none"> ● No European sea shows significant cooling
Marine species composition	<ul style="list-style-type: none"> ● Over the past 30 years there has been a northward shift of zooplankton species by up to 1000 km and a major reorganization of plankton ecosystems
<i>Terrestrial ecosystems and biodiversity</i>	
Plant species composition	<ul style="list-style-type: none"> ● Climate change over the past three decades has resulted in decreases in populations of plant species ● By 2050 species distribution is projected to become substantially affected in many parts of Europe
Plant phenology and growing season	<ul style="list-style-type: none"> ● The average annual growing season in Europe lengthened by about 10 days between 1962 and 1995 and is projected to increase further in the future ● Greenness (a measure of plant productivity) of vegetation increased by 12%, an indicator of enhanced plant growth
<i>Agriculture</i>	
Crop yield	<ul style="list-style-type: none"> ● Agriculture in most parts of Europe, particularly in mid and northern Europe, is expected potentially to benefit from increasing CO₂ concentrations and rising temperatures

(Continued)

Table 1.2 (Continued)**Indicators****Key messages**

Economy
Economic losses

- The cultivated area could be expanded northwards
- During the heatwave in 2003, many southern European countries suffered drops in yield of up to 30%
- In Europe, 64% of all catastrophic events since 1980 are directly attributable to weather and climate extremes: foods, storms and droughts/heatwaves; 79% of economic losses caused by catastrophic events result from these weather and climate related events

Adapted from

http://reports.eea.europa.eu/climate_report_2_2004/en/impacts_of_europes_changing_climate.pdf

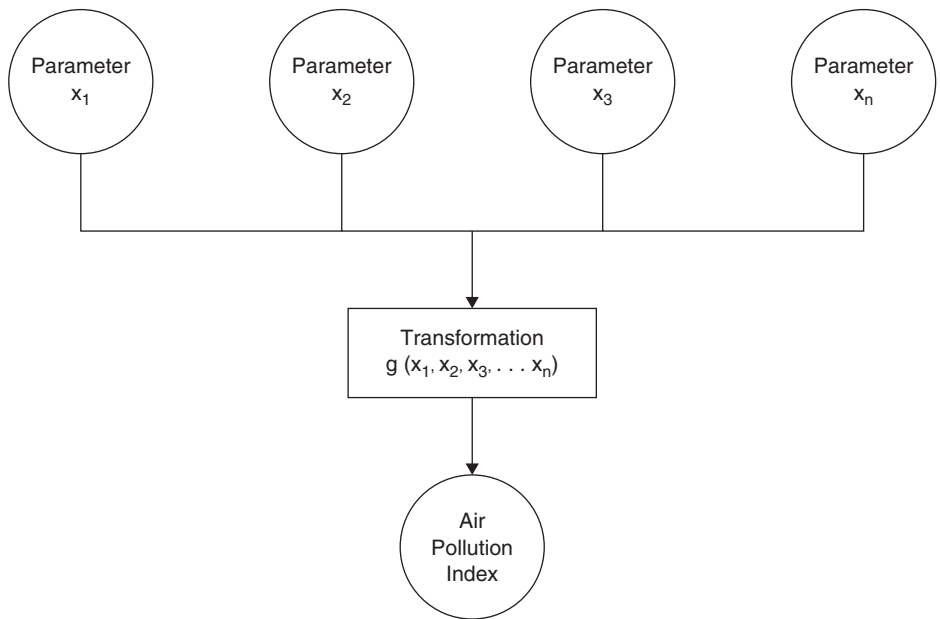

Figure 1.3 Index calculation (adapted from Rao and Rao, 2000)

An ‘Air Pollution Index’ can be defined as a scheme that transforms the (weighted) values of individual air pollution related parameters (for example, sulfur dioxide concentration or suspended particulate matter) into single number or set of numbers. Index calculation is shown in Figure 1.3. Air quality indices can be broadly classified into two groups: i) short-term indices and ii) long-term indices. These indices are commonly used by the local and state air pollution control agencies. These indices are very helpful for the purpose of assessing the effectiveness of enforcement policies with regard to pollution control measures, in improving air quality. A typical rating scale for indices is given in Table 1.3. Generally the parameters used for calculating the air pollution index are

Table 1.3 Typical rating scales for air pollution indices

Index values	Remarks
0-25	Clean air
26-50	Light air pollution
51-75	Moderate air pollution
76-100	Heavy air pollution
>100	Severe air pollution

Adapted from Rao and Rao, 2000

suspended particulate matter (SPM), sulfur dioxide (SO₂), carbon monoxide (CO), nitrogen dioxide (NO₂), photochemical oxidant (principally ozone O₃) and hydrocarbons. A standardized index (uniform air pollution index) should satisfy the following criteria:

- 1 include major pollutants
- 2 calculated in a simple manner
- 3 consistent with perceived air pollution levels
- 4 spatially meaningful
- 5 exhibit day-to-day variation
- 6 relate to ambient air quality standards and goals
- 7 can be forecast a day in advance (if possible).

There are several methods and equations used for determining the air pollution index (Rao and Rao, 2000). A few of these methods and equations are given in Table 1.4.

Large amounts of fuels, burned in various types of furnaces, are one of the main sources of pollution in the environment. Flue gases pollute the atmosphere and the associated ashes pollute soil and water. To compare the influence of various fuels burned in different installations on the environment, one universal index would be helpful. Such a coefficient, which represents the harmfulness of combustion processes of a particular fuel in a particular installation, is defined in a report. This coefficient takes into account the composition of the fuel, the thermal efficiency of the installation, the type and process efficiency of creation of harmful compounds in the combustion chamber, efficiency of cleaning devices, ability of emitter to propagate pollutants into the atmosphere, as well as the relative toxicity of various components. Finally, methods of calculation of propagation of pollutants in the atmosphere are introduced. All these factors are essential for a reliable assessment and comparison of fuel and installations. An individual coefficient of harmfulness could be calculated for each compound present in the fuel gases as well as a total coefficient for all compounds. Each compound created in the combustion processes is the source of many types of environmental impact. It could have significant influences on human health, plants and animals as well as, for example, on the corrosion process taking place in many different installations. It has to be taken into consideration that the result of a combustion process could appear in many different places, sometime distant from the place of the process itself. All these results should be analyzed and introduced into the universal coefficient of 'harmfulness' of

Table 1.4 Methods and equations used for determining the Air Pollution Index

Method	Characteristics	Equation and examples
1st method	<ul style="list-style-type: none"> It is tried to relate the existing pollution level of various pollutants to their ambient air quality standards, with the standard being assumed as the reference base line for each pollutant and then converting the concentration of pollutants into a percentage of the standard The Air Pollution Index is then obtained by adding the percentages for the several pollutants considered 	<p>For example, in case of six pollutants: $I = 1/6 \sum A_i$, $A_i = C_i/S_i \times 100$ I = Air Pollution Index A_i = Air Pollution Sub-index C_i = Concentration of pollutant S_i = Air quality standard for pollutant</p>
2nd method	<ul style="list-style-type: none"> The average of the sum of the ratios of three major pollutant concentrations to their respective air quality standards is obtained The average is then multiplied by 100 to obtain the index 	<p>For example, in case of three major pollutants in a city: particulate matter, sulfur dioxide and carbon monoxide: $API = 1/3 (PM/S_{PM} + SO_2/S_{SO_2} + CO/S_{CO}) \times 100$ S_{PM}, S_{SO_2} and S_{CO} = ambient air quality standards for particulate matter, sulfur dioxide and carbon monoxide, respectively</p>
3rd method	<ul style="list-style-type: none"> Air Pollution Index is calculated from five sub-indices Each sub-index is obtained by assigning sub-index values for particular ranges of pollutant concentrations 	<p>$I = \sum A_i$ I = Air Pollution Index A_i = Air Pollution Sub-index</p>
4th method	<ul style="list-style-type: none"> This method is known as the maximum type It is used for only one pollutant index among the several pollutants 	<p>The only one pollutant index is the highest one</p>
5th method	<ul style="list-style-type: none"> This method is used for only two common pollutants These pollutants are taken into account while calculating the Air Pollution Index 	<p>For example, the pollutants are particulate matter and sulfur dioxide</p>
6th method	<ul style="list-style-type: none"> This method is used for only one major pollutant This pollutant is taken as the basis for reporting the Air Pollution Index 	<p>For example, the pollutant is ozone concentration</p>

Adapted from Rao and Rao, 2000

specific compounds. Economic parameters and methods are important and therefore are also introduced into the assessment method (Pikon, 2003).

Levitan (1997, 2000) proposed a typology to distinguish among three quite different types and applications for pesticide impact assessment tools (which are also known as ‘pesticide risk indicators’):

- 1 decision support systems for farmers and other property managers
- 2 ‘ecolabeling’ or ‘green labeling’ systems designed to influence consumer opinion and market behavior

3 indicators of impact and risk used by governments, industry and academia to assess policies and programs.

These types are differentiated by their objectives, decision-makers, factors or variables considered, arena of activity, scale and unit of analysis, handling of an economic dimension, format of results and method or approach. A number of different types of risks are associated with pesticides including the risk of:

- 1 unintended adverse effects on non-target biota
- 2 exposure, i.e. risk of pesticide residues on food
- 3 pest resistance of pest controls
- 4 disease or loss of food and fiber because pests are not controlled
- 5 harm to natural or agro-ecosystem
- 6 greater cost for pest control
- 7 consumption and degradation of resources.

Both the Environmental Impact Quotient (EIQ) developed by Kovach *et al.* (1992) and the California Seminar system developed by Pease *et al.* (1996) focus on agricultural pesticides uses.

In this typology, a range of assessment systems used for many distinct purposes fall under the rubric of policy tools. More specifically, the types of policy tools include:

- 1 screening systems to assess quickly preliminary data for hazard signals
- 2 analyses by regulatory agencies that evaluate pesticide use and risks over time
- 3 evaluations of risks from individual pest control products and practices
- 4 criteria for pesticides usage tax programs
- 5 evaluations of the success and/or relative or absolute costs and benefits of programs and policies
- 6 assessments of the adoption of IPM on farms and in schools
- 7 evaluations of the success of IPM in meeting its objectives to control pests. The typology of pesticide risk indicators is given in Table 1.5.

A number of pesticide ranking systems are based on simple algebraic equations, using a format similar to plant breeding selection indexes (Cotterill and Dean, 1990) and multiattribute indicators used in the social sciences (Putnam, 1993). A generalized form of these equations is:

$$\text{Environmental Impact Index Value}_{\text{COMPOSITE}} = f(b_1x_1 + b_2x_2 + b_3x_3 + \dots + b_ix_i)$$

An array of index values for a set of variables, with no composite index value calculated is given in Table 1.6.

Consumers Union's agricultural pesticide risk index was developed by Charles Benbrook and others (1996) to assess whether regulatory policies have succeeded in reducing pesticide risk since the US Federal Insecticide, Fungicide and Rodenticide Act (FIFRA) was revised in 1972. Two weighted indexes of risk were derived, one from acute toxicity indicators for mammals and another from chronic toxicity indicators.

Table 1.5 Typology of pesticide risk indicators

Criteria	Category of Pesticide Risk Indicator		
	Decision support	Ecolabel	Policy analysis
Objectives	Inform re: potential environmental and economic consequences of pest management decision	Encourage production and purchase of goods that meet a set of environmentally-sensitive criteria	Monitor trends in pesticide use and risk; warn about hazards/potential risks
Decision-maker	Property owner, manager (e.g. farmer)	Group providing accreditation; consumer	Researchers, advocates, policy-makers
Factors or variables considered	All factors taken into account in making the decision	Set of factors deemed important by group conferring the ecolabel	Single or multiple factor(s) relevant to specific policy or issue
Scale of analysis	Field or enterprise	Farm or food processing facility	Production region, nation, world
Unit of analysis	Pest management incident or strategy	Output from a facility (e.g. the apples from a farm)	Total quantity of pest control products
Economic dimension	When included, typically just production costs	Choice exercised by consumer; price premium and/or increased market share for producer	Cost to society, market externalities
Format of results	Link process with result in workbook or computerized expert system	Separate decision process from result with ecolabel on product	Tabular or graphical results summary
Method or approach	Interactive decision-tree	Checklist of criteria	Algebraic equation or screening checklist

Adapted from Levitan, 2000

Table 1.6 An array of index values for a set of variables, with no composite index value calculated

	Environmental indicators			
	1	2	3	i
Pesticide A	Index value A ₁	Index value A ₂	Index value A ₃	Index value A _i
Pesticide B	Index value B ₁	Index value B ₂	Index value B ₃	Index value B _i
Pesticide C	Index value C ₁	Index value C ₂	Index value C ₃	Index value C _i

Adapted from Levitan, 1997

These indices were used in combination with US agricultural pesticide usage data for 1971, 1982 and 1992 to assess trends (Table 1.7). Results indicate that the trend in pesticide risk to public health has been flat – neither acute nor chronic risks to human beings have declined from 1971 to the present. For each of three years studied, a dozen or fewer active ingredients account for most ($\geq 75\%$) of the pesticides applied in each major class (herbicides, insecticides and fungicides). Charles Barnard, an economist with the Environmental Indicators Branch of USDA Economic Research Service (ERS), has developed two indicators of pesticide risk to human beings that were publicly unveiled in the ‘Pesticide Use’ module of the USDA ERS Agricultural Handbook

Table 1.7 Consumer Union Index of pesticide risk equation factors

Variables	Indicators
Acute toxicity to human beings	Rodent LD ₅₀ values Reference dose (RfD)
Chronic toxicity to human beings	Cancer potency (Q*) EPA cancer classification (Group A, B, C) Endocrine system disruption potential
Agricultural use	Pounds applied in US agriculture/year

Adapted from Benbrook *et al.*, 1996

entitled 'Agricultural Resources and Environmental Indicators' (1997). Historically, ERS has relied on pounds of pesticides applied as the basis of pesticide usage data. Pesticide weight was therefore also being used as the *de facto proxy* for pesticide risk. Currently, several initiatives are underway at ERS to develop other risk indicators. Among these are Barnard's potential risk measures for acute and chronic toxicity based upon 'toxicity/persistence units' (TPUs). The objective is to improve time series analysis of national pesticide risk by using these as toxicity-weighted measures of pesticide use. The method also enables identification of geographic regions at greater risk from pesticide use and identification of pesticide classes and uses posing greatest risk.

References

- Anonymous. (1993). In Anonymous Peterborough, pp. 9–17. *English Nature*.
- Bahloui, M.A., Baleux, B. and Troussellier, M. (1998). Dynamics of pollution indicator and pathogenic bacteria in high-rate oxidation wastewater treatment ponds. *Water Res* **31**, 630.
- Baldrian, P. and Gabriel, J. (1997). Effect of heavy metals on the growth of selected wood-rotting basidiomycetes. *Folia Microbiol* **42**, 521.
- Beeson, D.R., Lewis, M.C., Powell, J.M. and Nimmo, D.R. (1997). Effects of pollutants on freshwater organisms. *Water Environ Res* **70**(4), 921–930.
- Bellas, C.P. and Skourtos, M.S. (1996). Environmental regulation and costs of information: some indications from Greek industry. *J Environ Manage* **47**, 205–221.
- Benbrook, C., Groth, E., Halloran, J.M., Hansen, M.K. and Marquardt, S. (1996). Pest management at the crossroads. *Consumer Union*, 272.
- Bernard, C. (1997). Pesticide use. In *Agricultural Resources and Environmental Indicators* (M. Anderson, ed.). USDA ERS, Agricultural Handbook.
- Bouchard, D.C. *et al.* (1992). Nitrate contamination of groundwater: sources and potential health effects. *J Am Water Works Assoc* **84**, 85.
- Boudouropoulos, I. and Arvanitoyannis, I.S. (1999). Current state and advances in the implementation of ISO 14000 by the food industry. Comparison of ISO 14000 to ISO 9000 to other environmental programs. *Trends Food Sci Technol* **9**, 395–408.

- Boudouropoulos, I. and Arvanitoyannis, I.S. (2000). Potential and perspectives for application of Environmental Management System (EMS) and ISO 14000 to food industries. *Food Rev Int* **16**(2), 177–237.
- Calvarano, M., Postorino, E., Gionfriddo, F., Calvarano, I. and Bovalo, F. (1996). Naringin in extraction from exhausted Bergamot peels. *Perfumer Flavorist* **21**, 1–3.
- Carr, L.E. (1992). Hatchery waste composting. *Proceedings of the 1992 National Poultry Water Management Symposium*, Alburn, AL, Arburn University, 139.
- Cheng, S.S., Ho, C.Y. and Wu, J.H. (1997). Pilot study of UASB process treating PTA manufacturing wastewater. *Water Sci Technol* **36**(6), 73.
- Chung, K., Starrett, S., Chung, Y. and Ro, K.S. (1998). Pesticides and herbicides. *Water Environ Res* **70**(4), 693–697.
- Cotterill, P.P. and Dean, C.A. (1990). Successful tree breeding with index selection. CSIRO Australia, Division of forestry and forest products, Mt Gambier, p. 80.
- De Hollander, R.G. (1998). Gaseous emissions from wastewater facilities. *Water Environ Res* **70**(4), 580–585.
- Deka, K.C., Dutta, D.N. and Goswami, M.M. (1996). DDT residues in milk samples from Jorhat and surrounding areas. *Plant Health* **1**, 1–6.
- Deml, E., Mangelsdorf, I. and Greim, H. (1996). Chlorinated dibenzodioxins and dibenzofurans (PCDD/F) in blood and human milk of non-occupationally exposed persons living in the vicinity of a municipal waste incinerator. *Chemosphere* **33**, 1941–1950.
- DOE (Department of the Environment). (1989). *Environmental appraisal: a guide to the procedures*. HMSO, London.
- Dowie, W.A., McCartney, D.M. and Tamm, J.A. (1998). A case study of an institutional solid waste environmental management system. *J Environ Manage* **53**, 137–146.
- Durrant, J.R. (1998). Lighting the way to green energy. *Chem Industry* 838–841, October 19.
- Edwards-Jones, G., Davies, B. and Hussain, S. (2000). *Ecological Economics*, pp. 121–130, 139–143. Blackwell Science, Oxford.
- el Nawawi, S.A. (1995). Extraction of citrus glucosides. *Carbohydr Polym* **27**, 1–4.
- Environmental Protection Act* (1990), Part I, 1995. Revision P63/3(95).
- European Environment Agency. (2004). Impacts of Europe's changing climate, an indicator-based assessment, No 2/2004 (http://reports.eea.europa.eu/climate_report_2_2004/en/impacts_of_europes_changing_climate.pdf)
- 4th Ministerial Conference Environment for Europe*, Denmark, June (1998), Erhus, pp. 23–25.
- Freire, E.O. (1997). *Wastewater recycling in Minas Gerais, Brazil: Case studies in Rocas Novas and Canabrava*. Paper presented at the WEF Beneficial Reuse of Water and Biosolids Specialty Conference, Malaga, Spain.
- Fries, G.F. (1991). Organic contaminants in terrestrial food chains. In *Organic contaminants in terrestrial food chains* (K.C. Jones, ed.), pp. 207–236. Elsevier Applied Science, London and New York.
- Gemar, C. (1991). How new pretreatment regulations affect industry. *Water Engine Manage* **138**, 28.
- Gerard, D., Quirin, K.-W. and Schwarz, E. (1995). CO₂-Extracts from rosemary and sage. *Food Marketing Technol* **9**, 46.

- Gergova, K. *et al.* (1994). Adsorption properties and microstructure of activated carbons produced from agricultural by-products by steam pyrolysis. *Proceedings from the 21st Biennial Conference Carbon*, Buffalo, pp. 32–693.
- Gilpin, A. (1995). *Environmental impact assessment, cutting edge for the twenty-first century*, pp. 16–17, 24–27. Cambridge University Press.
- Glasson, J., Therivel, J. and Chadwick, A. (1999). Environmental impact assessment of projects not subject to planning control. In *Environmental impact assessment of projects not subject to planning control*, 2nd edn, pp. 5–131, 281–325. UCL Press Ltd, London.
- Graham, C.M. and Weathers, L.J. (1997). Fermentation industry. *Water Environ Res* **69**(4), 620–626.
- Grant, S.R. *et al.* (1994). The effect of temperature on performance of sequencing batch reactors treating potato processing wastewater. *Proceedings from the 49th Industrial Waste Conference*, Purdue University, Lafayette, p. 709.
- Grismer, M.E. and Shepherd, H.L. (1998). Fermentation industry. *Water Environ Res* **70**(4), 637–646.
- Guadagnino, E. Dall'Igna (1996). Heavy metal ions in glass and related legislation. *Glass Technol* **37**(3), 76–79.
- Gulli, F. (2006). Social choice, uncertainty about external, costs and trade-off between intergenerational environmental impacts: The emblematic case of gas-based energy supply decentralization. *Ecol Econom* **57**, 282–305.
- Hammonds, M. (1998). Getting power from the sun. *Chem Industry* 219–222, March 16.
- Hiddink, J. (1995). Water supply, sources, quality and water treatment in the dairy industry. *Bull IDF* **308**, 16–32.
- Hunt, R. and Hunt, J. (1998). Hydropower: turning water into light. *Chem Industry* 227–230, March 16.
- IPCC (2001). *Climate change 2001: the scientific basis*. Cambridge University Press, Cambridge, UK.
- Jang, M., Udeani, G.D., Slowing, K.V. *et al.* (1998). Cancer chemopreventive activity of resveratrol, a natural product derived from grapes. *Science* **275**, 218–200.
- Jimenez, A.M., Borja, R., Alonso, V. and Martin, A. (1997). Influence of aerobic pretreatment with penicillium decumbens on the anaerobic digestion of beet molasses alcoholic fermentation wastewaters in suspended and immobilized cell bioreactors. *J Chem Technol Biotechnol* **69**, 193.
- Jones, R.H. and Horvath, J. (1993). Treatment of strong citrus wastewater by spray irrigation. *Proceedings of the 1992 Food Industrial Environment Conference*, Tech., Res. Int., Atlanta, p. 435.
- Kefalas, P. (1991). *Suggestions for the exploitation of the agro-industrial waste*. Personal Communication VIORYL SA, Athens.
- Knight, R.L. (1997). Wildlife habitat and public use benefits of treated wetlands. *Water Sci Technol (GB)* **35**, 5.
- Kobylinski, E.A. and Hunter, G.L. (1992). Wastewater: new environmental regulations pose challenges for industry. *Chem Engine* **99**, 74.
- Kolhatkar, A. and Sublette, K.L. (1996). Biotreatment of refinery spent sulfide caustic by specialized cultures and acclimated activated sludge. *Appl Biochem Biotechnol* **57**, 945.

- Kordesch, K.V. and Simander, G.R. (1995). Environmental impact of fuel cell technology. *Chem Rev* **95**, 191–207.
- Kovach, J., Petzoldt, C., Degni, J. and Tette, J. (1992). A method to measure the environmental impact of pesticides. *New York's Food Life Sci Bull* **139**, 8.
- Krokos, F., Creaser, C.S., Wright, C. and Startin, J.R. (1996). Levels of selected ortho and non-ortho polychlorinated biphenyls in UK retail milk. *Chemosphere* **33**, 1941–1950.
- Kuo, J.F., Dodd, K.M., Chen, C.L., Horvath, R.W. and Stahl, J.F. (1997). Evaluation of tertiary filtration and disinfection systems for upgrading high-purity oxygen-activated sludge plant effluent. *Water Environ Res* **69**, 34.
- Laine, M.M. and Jorgensen, K.S. (1997). Effective and safe composting of chlorophenol-contaminated soil in pilot scale. *Environ Sci Technol* **29**, 836.
- Levitan, L. (2000). 'How to' and 'why': assessing the enviro-social impacts of pesticides. *Crop Protect* **19**, 629–636.
- Levitan, L. (1997). *An overview of Pesticide Impact Assessment systems based on Indexing or Ranking by Environmental Impact*, pp. 23–25, 57–59. Cornell University, Ithaca.
- Liang, Y. *et al.* (1997). Research on the characteristics of start up and operation of treating brewery wastewater with an AFB reactor at ambient temperatures. *Water Sci Technol* **28**(7), 187.
- Liu, F., Mitchell, C.C., Hill, D.T., Odom, J.W. and Rochester, E.W. (1997). Phosphorus recovery in surface runoff from swine lagoon effluent by overland flow. *J Environ Qual* **26**, 995.
- Lopez-Carillo, L., Torres-Arreola, L., Torres-Sanchez, L., Espinosa-Torres, F. and Jimenez, C. (1996). Is DDT use a public health problem in Mexico? *Environ Health Perspect* **104**, 584–588.
- Lowe, E.D. and Buckmaster, E.R. (1994). Composting of food residuals at a snack food facility in Pennsylvania. *Proceedings of the 1994 Food Industrial Environmental Conference*, Tech., Res. Int., Atlanta, p. 183.
- Lundstrom, I., Shivamarar, M.S., Svensson, C.M. and Lundkvist, L. (1975). A hydrogen-sensitive MOS field-effect transistor. *Applied Physics Lett* **26**, 55.
- Marr, J.B. and Facey, R.M. (1995). Agricultural waste. *Water Environ Res* **67**(4), 503–507.
- Mayer, E.S. (1995). Wastewater treatment experiments at the Gabriel Sedlmayr Spaten-Franziskaner-Brau. *Brauwetl (Ger)* **131**, 2346.
- Mazza, G. (1995). Anthocyanins in grapes and grape products. *Crit Rev Food Sci Nutrit* **35**(4), 341–371.
- McGrath, S.P., Dunham, S.J. and Atkin, R.K. (1998). An extracting science. *Chem Industry* 915–918, November 16.
- Milborrow, D. (1998). Catching the breeze. *Chem Industry* 214–218, March 16.
- Morais, M.H. and Santos, O.J. (1995). Reduction of pollution from wine distilleries by the A-B process. *Proceedings of the International Spec. Conference on Winery Wastewaters*, Narbonne, p. 73.
- Norman, D. (1997). Norman environmental management systems. *Glass Technol* **38**(5), 146–149.
- Ormerod, B. (1998). A salty solution for carbon dioxide. *Chem Industry* 569–572, July 20.
- Ozturk, I. *et al.* (1992). Anaerobic treatment of olive mill effluents. *Proceedings of the 46th Industrial Waste Conference*, Purdue University, West Lafayette, p. 741.

- Pankakoski, M., Lagaisse, F., Nakayama, H. *et al.* (1993). Environmental influence of chemicals used in the dairy industry which can enter dairy wastewater. *IDF Bull* **288**, 17–31.
- Papanidis, M. (1999). *The nutritional bomb is orbiting the globe*. Makedonia, Greece, 20 Newspaper article, 20/6/1999.
- Pease, W.S., Liebman, J., Landy, D. and Albright, D. (1996). Appendix 1. In *Pesticide Use in California: strategies for reducing environmental health impacts. An environmental health policy program report*, pp. 63–93. Centre for occupational and environmental health, School of Public Health, California Policy Seminar, University of California, Berkeley.
- Pikon, K. (2003). Environmental impact of combustion. *Appl Energy* **75**, 213–220.
- Pissoloto, T.M., Schossler, P., Geller, A.M. and Casramao, E.B. (1996). Identification of phenolic compounds in wastewater from coal gasification by SPE and GC/MS. *J High Resol Chromatogr* **19**, 577–580.
- Price, H.A. and Welch, R.L. (1972). Occurrence of polychlorinated biphenyls in humans. *Environ Health Perspect* **1**, 73–78.
- Prokop, W.H. (1992). Rendering plant odor control technology. *Proceedings of the 1992 National Poultry Water Management Symposium*, Auburn University, Auburn, p. 228.
- Putnam, R. (1994). *Making democracy work*. Princeton University Press, Princeton.
- Rahim, R.A. and Watson-Craik, I.A. (1997). The co-disposal of a model brewery wastewater with domestic refuse. *Lett Appl Microbiol* **24**, 281.
- Rao, M.N. and Rao, H.V. (2000). *Air pollution*, pp. 269–272. Tata McGraw-Hill Publishing Company, New York.
- Reish, D., Oshida, P.S., Mearns, A.J., Ginn, T.C., Godwin-Saad, E.M. and Buchman, M. (1997). Effects of pollution on saltwater organisms. *Water Environ Res* **69**(4), 877–892.
- Reish, D., Oshida, P.S., Mearns, A.J., Ginn, T.C., Godwin-Saad, E.M. and Buchman, M. (1998). Effects of pollution on saltwater organisms. *Water Environ Res* **70**(4), 931–947.
- Riemer, P. (1998). Out of the air, into the ground. *Chem Industry* 563–567, July 20.
- Rogers, E.F. and Steidel, R.C. (1998). Case history: implementing a VOC RACT at a POTW dominated by industrial users. *Proceedings of Control Odors Volatile Organic Chemical Emissions Conference*, Houston, p. 11.
- Romero, L.I. *et al.* (1996). Microbiological purification kinetics of wine-distillery wastewaters. *J Chem Technol Biotechnol* **14**(3), 283.
- Rosales-Casian, J.A. (1992). Seawater chlorination and the survival and growth of early life stages of northern anchovy, with reference to power plant cooling systems. *Ciencias Marinas*, **17**, 99.
- Schrader, K.K., De Regt, M.Q., Tucker, C.S. and Duke, O.S. (1997). A rapid bioassay for selective algicides. *Weed Technol* **11**, 767.
- Schulte, S.R. (1994). Beverage plant waste minimization: a win–win strategy. *Proceedings of the 1994 Food Industrial Environmental Conference*, Tech., Res. Int., Atlanta.
- Scott, A.J. (1998). The contribution of forums to rural sustainable development: a preliminary evaluation. *J Environ Manage* **54**, 291–303.
- Scully, F.E., Hartman, A.C. and LeBlanc, N. (1996). Disinfection interference in wastewaters by natural organic nitrogen compounds. *Environ Sci Technol* **30**, 1465.
- Sielken, R.L. (1987). Statistical evaluations reflect the skewness in the distribution of TCDD levels in human adipose tissue. *Chemosphere*, **16**, 2135–2140.

- Skinner, J.A., Lewis, K.A., Bardon, K.S., Tucker, P., Catt, J.A. and Chambers, B.J. (1997). An overview of the environmental impact of agriculture in the UK. *J Environ Manag* **50**, 111–128.
- Slater, D. (1997). An overview of environmental matters for the glass industry. *Glass Technol* **38**(4), 108–111.
- Spash, C.L. (1997). Ethics and environmental attitudes with implications for economic valuation. *J Environ Manage* **50**, 403–416.
- Spetz, A.L., Tobias, P., Ekedahl, L.G., Martensson, P. and Lundstrom, I. (1998). *Fast chemical sensors for emission control*. The Electrochemical Society Interface, Winter, 34–38.
- Steel, B.S. (1996). *Thinking globally and acting locally?: environmental attitudes, behavior and activism*, pp. 27–36. Elsevier Applied Science, London and New York.
- Stott, R., Jenkins, T., Salem, M. and Butler, J. (1997). *Removal of parasite ova from domestic wastewater by gravel bed hydroponic constructed wetlands*. Paper presented at the WEF Beneficial Reuse of Water and Biosolids Specialty Conference, Malaga, Spain.
- Teixeira, A.C. and Balassiano, G.L. (1991). Process development in phenolic wastewater treatment. *Water Sci Technol* **24**, 77.
- Treshow, M. and Anderson, F.K. (1991). *Plant stress from air pollution*, pp. 3–5. John Wiley & Sons, Chichester.
- Turner, R.K., Salmons, R., Powell, J. and Craighill, A. (1998). Green taxes waste management and political economy. *J Environ Manage* **53**, 121–136.
- UNECE (1990). Ost-project analysis in environmental impact assessment. *Environmental series 3*, p. 29. UN, New York.
- Van Riper, C. and Geselbracht, J. (1998). Water reclamation and reuse. *Water Environ Res* **70**(4), 586–590.
- Venkatesh, M. (1997). Control VOCs from wastewater systems. *Chem Eng Prog* **93**, 33.
- Visioli, F., Vinceri, F.F. and Gali, C. (1995). Wastewaters from olive oil production are rich natural antioxidants. *Experientia* **51**, 32–34.
- Walsh, J.L., Ross, C.C. and Valentine, G.E. (1993). Food processing waste. *Water Environ Res* **65**(4), 402–407.
- Walsh, J.L., Ross, C.C. and Valentine, G.E. (1995). Food processing waste. *Water Environ Res* **67**(4), 522–527.
- Weathers, M.J. (1996). Fermentation industry. *Water Environ Res* **68**(4), 533–535.
- Webster, T.S., Devanny, J.S., Torres, E.M. and Basrai, S.S. (1997). Microbial ecosystems in compost and granular activated carbon biofilters. *Biotechnol Bioeng* **53**, 296.
- White, K.D. and Burken, J.G. (1998). Natural treatment and on-site processes. *Water Environ Res* **70**(4), 540–550.
- Wolfe, J. (1998). Capitalising on the sun. *Chem Indust* 224–226, March 16.
- Wright, P.M. (1998). Geothermal energy – harnessing heat from the centre of the earth. *Chem Industry* 208–212, March 16.
- Yong, N.K., Oshima, M., Blake, R. and Sugio, T. (1997). Isolation and some properties of an iron-oxidising bacterium thiobacillus ferrooxidans resistant to molybdenum ion. *Biosci Biotechnol Biochem* **61**, 1523.
- Zhu, J. and Chan, S. (1996). Approach for rapid automotive catalyst lightoff by high values of ignition retard. *J Inst Energy* **69**(480), 167.

ISO 14000: A Promising New System for Environmental Management or Just Another Illusion?

Ioannis S. Arvanitoyannis

Introduction of ISO 14000	39
The emergence of global environmental awareness	40
Technical Committee 207 (TC 207).....	43
Environmental management systems (EMS)	45
Benefits of implementing ISO 14000	49
ISO 14000: a new approach	50
ISO 14001: what it is and what it is not.....	51
Similarity of ISO 14000 to other programs	53
Applications of ISO 14000.....	59
ISO 14000 and banks	61
ISO 14000 and governments/education	62
ISO 14001 implementation	63
ISO 14010 – Environmental auditing.....	68
Brief presentation of new ISO 14001:2004	71
Overview of case studies reported on implementation of ISO 14001.....	72

Introduction of ISO 14000

The Green revolution has motivated consumers toward more environmentally friendly products. A product can be only qualified as being environmentally friendly when its life cycle ‘from cradle to grave’ respects the needs of the environment (Stauffer, 1997).

Strong public pressure in Europe and the USA has compelled companies to develop their own environmental management systems (EMS). The EMS considers a company’s

organization and the actions it takes with respect to environmental issues (Begley, 1997). Organizations contemplating the implementation of ISO 14000 should first evaluate the impact that an EMS will have on its internal structure and its ability to provide the comprehensiveness required to meet the external expectations. The management of environmental issues has radically changed the prevailing mentality from formal compliance with legislation to one of stewarding business operations voluntarily to meet environmental goals and objectives. ISO 14000 envisages the establishment of a proactive environmental management (<http://www.envir.com/iso/>).

The introduction of a set of new worldwide standards addressing environmental concerns, known as ISO 14000, is opportune because it offers a means of resolving extremely complex and controversial issues (Stauffer, 1997). The ISO has more than 130 member countries and its function consists of harmonizing existing national technical standards. ISO has previously implemented the 9000 standards which established a global standard of quality management. Strongly favored and supported by European companies, ISO 9000, though a voluntary standard, became a presupposition for most international companies that wished to extend their business in Europe. Although it was anticipated that a similar procedure would take place regarding the environmental standard ISO 14000, and that most international companies would require their suppliers to be certified (Tropea, 1997), this was not the case. Those opposed to ISO 14001 believed that it would only result in too much paperwork and very few benefits. Companies questioning the value of registration face several uncertainties. In particular, their main concern focused on understanding whether non-compliance with regulations, discovered during ISO 14001 auditing, could possibly result in exorbitant fines from government agencies, or whether ISO 14001 registration might be used by the governmental agencies as a means for reducing requirements for reporting, record keeping or monetary fines against companies. The fear of the initial cost of implementing an EMS was discouraging to some organizations especially smaller companies (Johannson, 1997; Petroni, 2001). Figure 2.1 shows the current state of ISO 14001 certificates worldwide.

The emergence of global environmental awareness

Although one of the first international symposia was held in Princeton, New Jersey, the world had to wait another 24 years before the introduction of an international standard (ISO 14000) (Tansey and Worsley, 1995). Some of the most important milestones that led to the development of the environmental standard ISO 14000 are given synoptically in Table 2.1. There is a growing critique on intensive agriculture developed in the industrial world which, though productive from a short-term economic viewpoint, has substantially reduced the biological complexity of farming systems because of its imposed strict production control aimed at increasing capital and energy inputs (Tansey and Worsley, 1995). The significance of the sustainable development concept to the emerging worldwide interest in environmental management is clearly shown by the voluntary adoption of many codes and charters that promote sustainability. One of the most

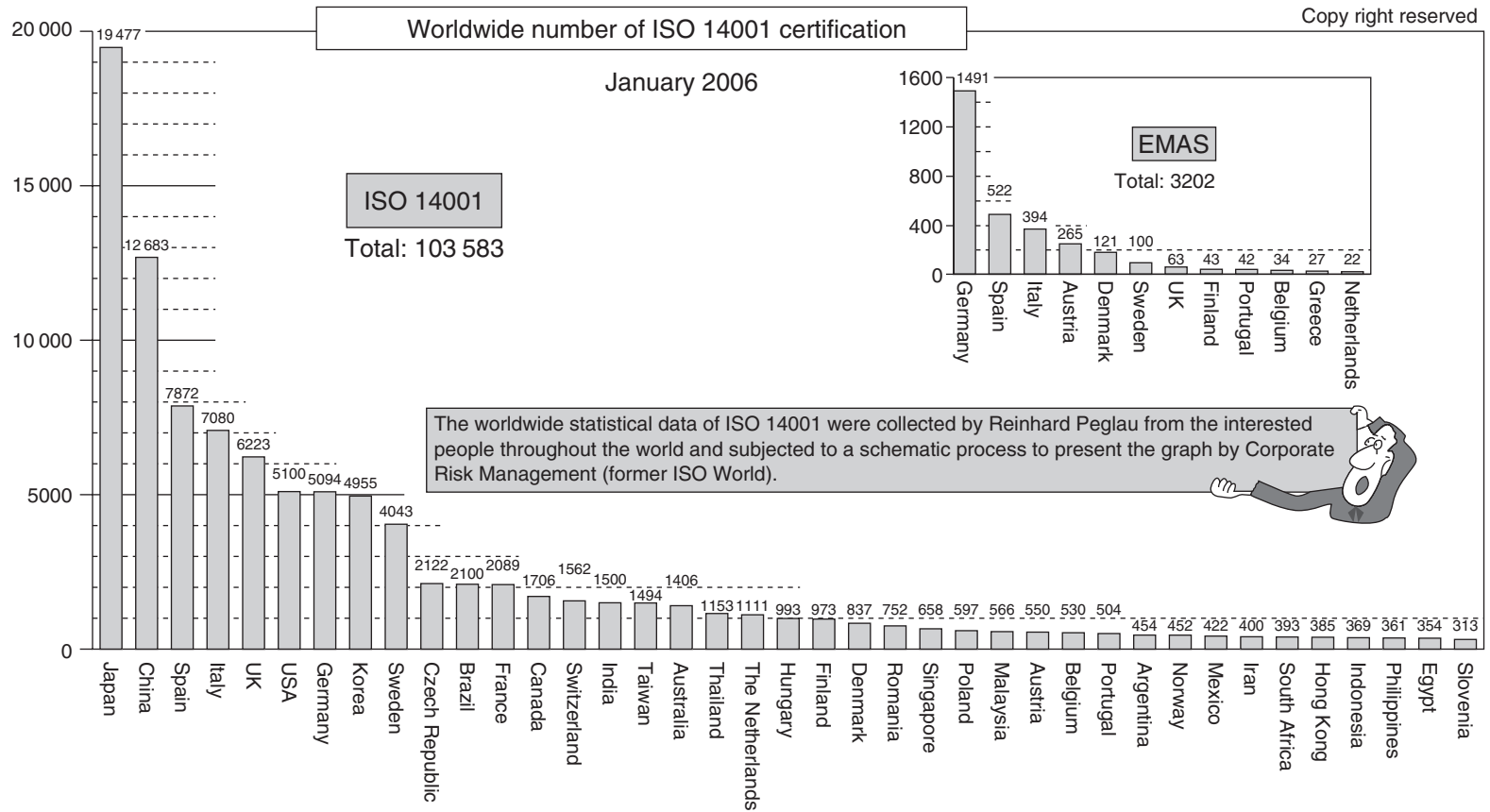

Figure 2.1 Current state of ISO 14001 certificates worldwide (January 2006) (<http://www.ecology.or.jp/>)

Table 2.1 Conception and development of various environmental standards across the world which led to ISO 14000

Year	Event
1955	Princeton (USA). International Symposium on Environment
1972	Stockholm. United Nations' sponsored conference on Human Environment
1980	Washington. Carter administration published its Global 2000 Report
1984	Responsible Care
1987	a) ISO 9000 b) Common Future c) Montreal Protocol d) SAGE recommends international trade
1988	a) CMA (USA) b) SAGE recommends international trade
1989	a) Costa Rica established INBio b) CERES
1991	Keidahren Charter (Japan)
1992	a) EU proposed Eco-Audit Management Regulation b) BS 7750
1993	EU agrees to adopt EMAS and EMAS is published
1994	BS 7750 revised
1995	EMAS goes into effect
1996	ISO 14000: 1996 series
2004	ISO 14000: 2004 series

Worsley, 1995; Tibor and Feldman, 1997

notable examples is the Business Charter for Sustainable Development developed by the International Chamber of Commerce (Tibor and Feldman, 1997). The ISO 14000 series emerged primarily as a result of the Uruguay round of the GATT negotiations (to reduce trade barriers) and the Rio Summit on the protection of the environment held in 1992. Over the past ten years, a steady growth of national and regional environmental standards has occurred (Boudouropoulos and Arvanitoyannis, 1999, 2000). The United Nations Conference on Environment and Development, or Earth Summit, Rio de Janeiro, Brazil, 1992, was convened to address global environmental issues and recommend solutions. The two most important results of this conference were the compilation of Agenda 21 and ISO 14000. The former is a comprehensive set of guidelines for achieving sustainability and was overwhelmingly adopted by 172 nations at the conference. ISO 14000 stands for a series of standards among which ISO 14001 addresses environmental management and pollution prevention (<http://www.quality.co.uk/quality>). By late 1994, several European countries had stated their intention to commit themselves to the basic principles of sustainability as expressed and formulated in the 1992 Rio Earth Summit. As for the USA, despite their leading role in developing national environmental legislation and environmental technology in the late 1960s and the early 1970s, they saw their role gradually shrinking by the late 1980s despite some isolated efforts such as the establishment of the Environmental Technology Initiative (ETI) in 1993 and the President's Council on Sustainable Development (PCSD) (Haklik, 1998).

New regulations requiring EMS in place are currently implemented in most countries. It has been a great challenge for the environmental management to decide which systems to design and how to implement them in a cost-effective way (Lash and Buzzelli, 1995). When one adds the comprehensive management systems that will now be required for ISO 14001 certification, the task for the environmental manager could easily become overwhelming. The first two published standards are ISO 14001 (EMS – Specification with guidance for use), and ISO 14004 (EMS – General guidelines on principles, systems and supporting techniques). These two documents are the pillars of the ISO 14000 series since they specify the requirements against which a company's EMS is to be judged. Further documents regarding auditing principles and procedures, auditor qualifications and life cycle assessment principles have been approved and published since October 1996.

Since 1997, various ISO 14000 committee documents have reached the draft international standard (DIS) stage. These documents focus on environmental labels and declarations, life cycle assessment and environmental management terms and definitions (<http://www.envir.com/iso/>; Hunt and Johnson, 1995).

Several proposed standards have been involved in the merging of environmental management and standardization. Figure 2.2 illustrates several of these environmental standards, such as BS7750, that have been considered. Many different organizations and individuals around the world have worked on the proposed standards in an attempt to make them as convenient as possible, user friendly and acceptable to all the countries that have endorsed ISO 14000 (<http://www.scc.ca/iso14000/infobref.html>).

Technical Committee 207 (TC 207)

The Strategic Advisory Group for the Environment (SAGE) recommended that the ISO should establish a new technical committee to develop standards in most of the following areas of:

- Environmental management systems (EMS)
- Environmental auditing (EA)
- Environmental performance evaluation (EPE)
- Life cycle analysis (LCA)
- Environmental labeling (EL)
- Terms and definitions (TandD)
- Environmental aspects of product standards (EAPS).

By early 1993, the ISO Technical Management board approved the SAGE recommendations and established a new technical committee, TC 207, to be responsible for the development of these standards. The management of the TC 207 secretariat was awarded to the Standards Council of Canada. In June 1993, the first plenary meeting of the new technical committee was held in Toronto (Canada).

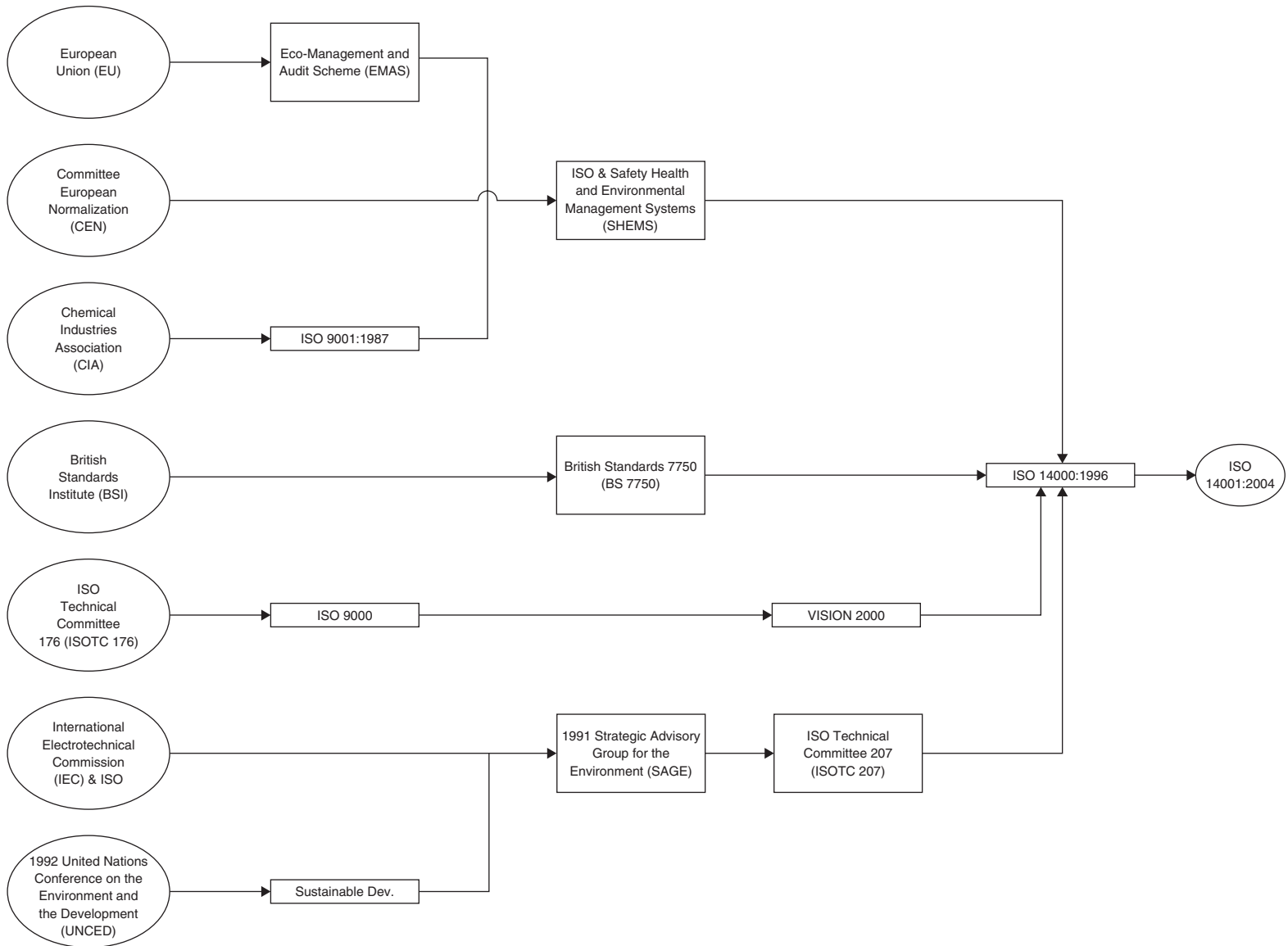

Figure 2.2 Evolution of ISO 14000

The TC 207, based on the recommendations of SAGE, set up six subcommittees and a working group with secretariats based in different countries (noted in parentheses):

- SC1 Environmental management systems (UK)
- SC2 Environmental auditing (The Netherlands)
- SC3 Environmental labeling (Australia)
- SC4 Environmental performance evaluation (USA)
- SC5 Life cycle analysis (France/Germany)
- SC6 Terms and definitions (Norway)
- WG1 Environmental aspects of product standards (Germany).

The standards developed by TC 207 could be divided into two categories: organizational and product-related (Kuhre, 1995; Barg, 1996).

Environmental management systems (EMS)

What is *environmental management*?

An EMS is a set of managerial activities defining the environmental policy and its objectives implementing these activities by means of planning for environmental objectives, measurement of results and the control of environmental effects (<http://www.tc207.org/articles/>).

EM is a tool for an organization to keep aware of the interactions that its products and activities have with the environment and to achieve and continuously improve the desired level of environmental performance (EP) (<http://www.infomintl.com/managesyslinks.html>).

What is an *environmental management system*?

It is the part of the overall management system which focuses on organizational structure, planning activities, responsibilities, practices, procedures, processes and resources for developing, implementing, achieving, reviewing and maintaining the environmental policy.

What is *environmental policy*?

They are goals and general objectives endorsed by the company concerning the environment. The adopted environmental policy should respect the corresponding environmental legislation and regulations. A prerequisite for making an appropriate selection of objectives and targets is the evaluation of environmental effects (Tibor and Feldman, 1997). A guiding principle in choosing and prioritizing objectives and targets is that these should address significant environmental effects, although ISO 14000 does not require that all these problems be simultaneously resolved (Lash and Buzzelli, 1995).

The International Standardization Organization's (ISO) vision of an EMS includes establishing an environmental policy that reflects 'the commitment of top management

of the company to compliance with applicable laws and continuous improvement' (Fredericks and McCallum, 1995). That policy forms the basis for setting objectives and targets and executing an environmental management program to achieve them through organizational structures, management controls and accountability. It also involves measuring and monitoring progress toward the targets, addressing problems and analyzing and revising the management system. However, specific performance goals are not part of an EMS (Begley, 1997).

To prevent organizations from either copying someone else's policy or writing flowery policies, the standard also requires that the organization ensures that its environmental policy satisfies two important conditions: the policy must be appropriate to the nature, scale and environmental impacts of its activities, products or services; a commitment must be stated with regard to continuous improvement, pollution prevention, compliance with relevant environmental legislation and regulations, or other requirements to which the organization subscribes (Jackson, 1997).

The organization's environmental policy must be documented, implemented, maintained and communicated to all employees and also available to the public (Lamprecht, 1996). The most basic requirements of an EMS are to establish and maintain an EMS including all requirements as described in the standard. The representative model for an EMS is based on five basic steps which are discussed in more detail in Table 2.2.

Table 2.2 The five basic EMS steps

1 Commitment and policy	Defining its environmental policy (EP) and ensuring commitment to it. Top management commitment to continuous improvement of the EMS, prevention of pollution and compliance with applicable law. EP relevant to the nature, scale and environmental impacts of activities, products and services. Policy documented, available to the public and communicated to employees
2 Planning	Development of a cross-functional team and identification of significant environmental impacts of activities, products and services, along with legal and other standards. Setting objectives and quantifying them wherever feasible
3 Implementation	Providing resources and support mechanism necessary to achieve the environmental policy and the objectives and targets. Defining the roles and responsibilities of all involved in the process, including senior management representatives. Identifying activities and processes with significant environmental impacts and implementing procedures to manage these activities and processes and training procedures
4 Measurement and evaluation	Measuring, monitoring and evaluating its environmental performance against its objectives and targets. Generation of specific procedures for conducting performance evaluations. Conducting EMS audits to identify areas that require improvement and non-conformances that must be corrected
5 Review and improvement	Developing procedures to review and continuously improve the EMS, with the objective of comparing the actual performance with targets

Tansey and Worsley, 1995; Hunt and Johnson, 1995; Shah, 1997; Jackson, 1997;
<http://www.mgmt14k.com/>

The characterization of environmental effects envisages identifying those past, present and planned organization's activities, products or services that have or could have an effect on the environment. It is required to consider the complete life cycle of products/services to assess the environmental effects. The characterization involves the following exercise:

- 1 Preparation of a material flow diagram (MFD) of materials (raw material, energy, water) between various sections/departments/units, starting from the receipt through the processing and finally to dispatch should be drawn
- 2 Preparation of a process flow diagram (PFD) in which steps of the process within a section/department, unit, through which materials flow, should be sketched
- 3 Carrying out mass balance (MB). After completing the process flow diagrams, the mass balance should be carried out for every significant step of the PFDs. For the mass balance, the format shown in Figure 2.3 may be used
- 4 Preparation of effects identification matrix.

Criteria and issues of an EMS

In executing an EMS audit, one should always keep in mind that the basic questions that should be answered are:

Is the EMS complete?

- 1 Environmental policy
- 2 Environmental program

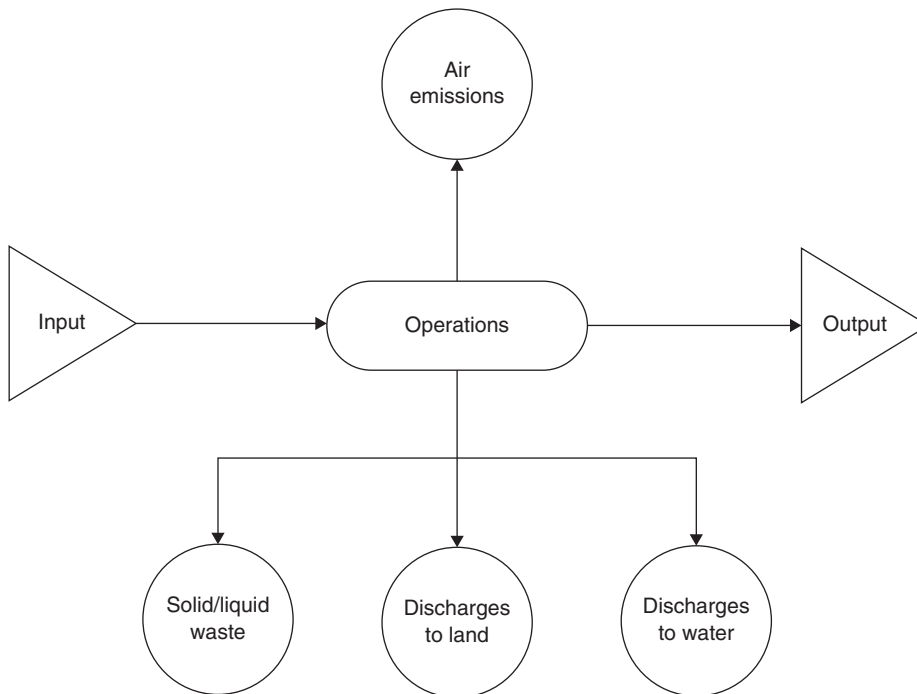

Figure 2.3 Mass balance (adapted from Arora, 2000)

- 3 Organizational structure, tasks, responsibilities, authorities
- 4 Internal and external communications
- 5 Procedures, instructions
- 6 Training and competence
- 7 Measuring and recording
- 8 Corrective mechanisms
- 9 Environmental auditing and management review processes
- 10 Emergency procedures and plans

Questions relating to environmental policy could then be:

- 1 Has the environment policy been established in writing?
- 2 Has it been communicated to all employees?
- 3 Is it appropriate to the nature, scale and environmental impacts of the activities, products and services?
- 4 Does it include a commitment to continual improvement of the environmental performance and to prevention of pollution?
- 5 Is it the right EMS for the activities involved?

This involves checking whether the EMS elements have been properly tailored to the nature and the complexity of the organization's activities and to the environmental aspects and impacts that are linked to them. For this criterion it will be necessary to check issues such as:

- 1 Local situation of the company
- 2 Air, water emissions and discharges
- 3 Waste production and disposal
- 4 Soil pollution
- 5 Handling and storage of raw materials, chemicals and hazardous substances
- 6 Collection and disposal of wastes
- 7 Technical environmental provisions
- 8 Process performance and management
- 9 Environmental risks
- 10 Maintenance aspects
- 11 Is EMS properly implemented?

The auditor should check whether the system has really been implemented at all levels and activities in the organization. Moreover, this check will have to be done by sampling. Checklists may include:

- 1 Availability and implementation of procedures
- 2 Training records
- 3 Availability of records and measurement reports
- 4 Whether the environmental policy has been communicated to all employees
- 5 Is the EMS suitable for meeting the environmental policy and objectives of the organization?

One can have a complete system, it can be tailored well to the nature and the complexity at hand, it can be implemented well and still it may not be sufficient to fulfill the organization's environmental policy and objectives. Therefore, the audit should also take into account checking the real environmental policy and objectives. Checks may include (Arora, 2000):

- 1 Checking measurements of emissions and discharges against objectives
- 2 Checking specific provisions in licenses and regulations for compliance.

Benefits of implementing ISO 14000

Among the benefits of ISO 14000 certifications are enhancement of a company's public image and defense strengthening against lawsuits. Mismanagement of environmental regulations can cause harsh penalties to companies and time-consuming lawsuits for not adhering to these regulations. The ISO 14000 standard can be modified, customized and implemented to meet the site-specific operations and business model (<http://www.envir.com/iso/>; Goodchild, 1998). The fear of the initial cost of implementing an EMS can be discouraging to some organizations, especially smaller companies. The companies that have not started even to consider how they might implement an EMS may find that their competitors are leaving them behind (<http://www.mgmt14k.com/>).

Companies that have implemented an EMS have realized improvements in the following areas (<http://www.envir.com/iso/>; Tansey and Worsley, 1995; <http://www.mgmt14k.com/>; Goodman, 1998; Petroni, 2001):

- Improved efficiency of operations and processes
- Environmental liability
- Reduced operating cost
- Management of supply change
- Increased productivity
- Improved financial performance
- Maintenance of consistent compliance with legislative and regulatory requirements
- Declining paperwork
- Waste reduction
- Improved community and customer relations
- Employee motivation
- Improved environmental performance
- Potential impact on world trade
- Improved customer satisfaction
- Assurance of conformity through third party verification
- Cooperation between management and employees
- Increased product quality
- Employees' responsibility
- Increased domestic market share.

Although pollution reduction is the goal of ISO 14000, its expected reduction is neither clearly prescribed nor quantified. Therefore, reduction results from voluntary actions supported by the management system. A challenge facing supporters of ISO 14000 is convincing companies to register to the standard because of the perception in industry that the benefits of registration may not outweigh the costs of the effort. In the USA, companies are accustomed to complying with environmental regulation and recognize such efforts as a cost of doing business. Although ISO 14001 provides a standard and comprehensive approach to EMS with many benefits to registration, it is possible that companies can have an effective EMS in place and good environmental performance without registration (<http://www.iso14000.com/>).

ISO 14000: a new approach

ISO 14000 embodies a new approach to environmental protection by challenging each organization to establish its own objectives and targets, commit itself to effective and reliable processes and continuous improvement and bring all employees and managers into a system of shared and enlightened awareness and personal responsibility for the environmental performance of the organization. Recent industrial accidents, occasionally entailing significant human and environmental harm, proved that regulatory compliance is not adequate for ensuring protection against environmental degradation. As it becomes clear that compliance was not a complete prescription for environmental protection, awareness arose that a more proactive system such as ISO 14000 was needed (Haklik, 1998).

From a strategic viewpoint, many organizations are focusing on issues such as quick response (to customer needs), customer relationships, core competence and continuous improvement, in addition to conventional indicators, including cost control and technology (<http://www.scc.ca/iso14000/>). Implementing an ISO 14001 EMS system could positively influence customers' perceptions about companies (Fredericks and McCallum, 1995).

ISO 14001 provides a framework to direct the use of organizational resources to the full breadth of actual and potential environmental impacts through reliable management processes and a base of educated and committed employees. Regulatory compliance is now a normal result of this management strategy, along with awareness, sensitivity and preparedness, greater reliability and consistency in meeting environmental objectives and greater confidence in the organization's ability to prevent accidents (Haklik, 1998).

The EMS can be documented in an environmental manual, or maintained in sections of the company's quality or operation manual. The EMS should clearly state the company's environmental goals (Tansey and Worsley, 1995). The real value and contribution of the 14001 standard can only be realized when it is used as a set of practical, certifiable tools to implement an environmental strategy. As with any good overall business strategy, the main focus of the environmental strategy needs to be the position of the firm and its products and services and its stakeholders (Cascio *et al.*, 1996). Effective environmental strategy implementation requires the definition of proactive

Table 2.3 The development of the ISO 14000 series

ISO 14000	Guide to environmental management systems: general guidelines
ISO 14001	Environmental management systems – Specification with guidance for use
ISO 14004	Environmental management systems – General guidelines on principle, systems and supporting techniques
ISO 14010	Guidelines for environmental auditing – General principles of environmental auditing
ISO 14011/1	Guidelines for environmental auditing – Audit procedures – Auditing of environmental management systems
ISO 14012	Guidelines for environmental auditing – Qualification criteria for auditors
ISO 14013	Management of environmental audit programs
ISO 14014	Initial reviews
ISO 14015	Environmental site assessments
ISO 14020	Environmental labeling – General principles
ISO 14021	Terms and definitions for self-declaration environmental claims
ISO 14022	Environmental labeling – symbols
ISO 14023	Environmental labeling – testing and verification methodologies
ISO 14024	Environmental labeling – guiding principles, practices and criteria for multiple criteria-based practitioner programs – guide for certification
ISO 14031	Evaluation of the environmental performance
ISO 14040	Environmental management – Life cycle assessment – principles and guidelines
ISO 14041	Environmental management – Life cycle assessment – goal and definitions/scope and inventory analysis
ISO 14042	Environmental management – Life cycle assessment – Life cycle impact assessment
ISO 14043	Environmental management – Life cycle assessment – interpretation
ISO 14050	Terms and definitions guide on the principles for ISO/TC SC6 terminology work
ISO 14060	Guide 64 for the inclusion of environmental actions in product standards

<http://www.envir.com/iso/>; Thayer, 1996; Tibor and Worsley, 1997; Boudouropoulos and Arvanitoyannis, 1999; <http://www.trst.com>, <http://www.scc.ca/iso14000/>

stakeholder management processes which support sustainable development and assist reconciliation of occasionally conflicting stakeholder interests (Canter, 1995; Thayer, 1996). The articles included in the ISO 14000 series are given synoptically in Table 2.3.

ISO 14001: what it is and what it is not

ISO 14001 requires that an organization develops an EMS to address all its environmental objectives and targets and describes how each will be achieved. The program must include a specific plan describing the actions required to meet each objective and target, the person(s) responsible for meeting each objective and a detailed time scale of when each target is due to be attained. Objectives and targets are usually prioritized within the program, but all of them must be included (Tansey and Worsley, 1995; <http://www.trst.com>).

One valuable feature of the ISO 14001 standard is the inclusion of a comprehensive and informative annex (Lamprecht, 1996). These core elements are recognized by all the countries (involved) as the minimum that would be acceptable on a global basis

(<http://www.scc.ca.iso14000/>). Not surprisingly, the scope of ISO 14001 is very broad and is intended for 'all types and sizes of organizations'.

The standard is applicable to *any* company/organization that wishes to:

- Implement, maintain and improve an EMS
- Assure itself of its conformance with its stated environmental policy and demonstrate it to others
- Seek certification/registration of its EMS by an external organization
- Make a self-determination and declaration of conformance with this environmental standard.

The opening paragraphs of ISO 14001 emphasize the following general objectives: supporting environmental protection in balance with socio-economic needs. The EMS can be integrated with other management requirements as found in the ISO 9000 series, for example.

In order to achieve environmental objectives, the EMS should encourage organizations to consider implementation of the *best available technology* where appropriate and where economically viable (EVABAT).

The standard is not intended to address and does not include requirements for aspects of occupational health and safety management. It does not seek to discourage an organization from integrating such management system elements. Furthermore, the standard does not state specific environmental performance criteria (Lamprecht, 1996).

Faced with society's increasing expectations, the Common Agricultural Policy (CAP) review considers environmental management to be an ever more critical criterion in the allocation of farm subsidies. With the goal of evaluating the environmental friendliness of farm practices, France's agricultural research and extension services have built a range of agricultural/environmental diagnostic tools over recent years. Galan *et al.* (2007) compared the five tools most frequently used in France required by the ISO 14001: IDEA, DIAGE, DIALECTE, DIALOGUE and INDIGO. All the tools have the same purpose: evaluation of the impact of farm practices on the environment via indicators and monitoring of farm management practices. When tested on a sample of large-scale farms in Picardie, the five tools sometimes produced completely different results: for a given farm, the most supposedly significant environmental impacts depend on the tool used. These results lead to differing environmental management plans and raise the question of the methods' pertinence.

An analysis grid of diagnostic tools aimed at specifying their field of validity, limits and relevance was drawn up. The resulting comparative analysis enables definition of each tool's domain of validity and allows suggesting lines of thought for developing more relevant tools for:

- 1 evaluating a farm's environmental performance
- 2 helping farmers to develop a plan for improving practices within the framework of an environmental management system.

Similarity of ISO 14000 to other programs

Comparing ISO 14001 and Responsible Care

The principles stated within the ISO 14001 EMS are certainly not new, since most of them have already been formulated by others often with greater clarity and more rigor. One could cite for example, the ten guiding principles of the Process Safety Code of Management Practices specified by the Chemical Manufacturers Association's (CMA) Responsible Care® initiatives. The concept of formulating a set of principles designed to improve the management of chemicals was first conceived by the Canadian chemical industry in 1988 and, in October 1990, the Responsible Care® initiatives were formally released. Responsible Care® was an obligation of CMA membership and all CMA members have pledged their unreserved support (Lamprecht, 1996). This costly, ambitious, and still unique, industry program was fashioned not only to change performance but also to alter industry's decision-making process and its relationship with the public. The main motivation was to transform public perception of an arrogant culture pursuing profits at any cost to one that could be trusted to protect public and workers' health and environment as well (Ember, 1995).

Both Responsible Care® and ISO 14001 heavily emphasize the concept of continuous improvement. The CMA declares continuous improvement in health, safety and environmental performance throughout the chemical industry to be the overriding goal of Responsible Care. ISO 14001, however, defines continuous improvement as the 'process of enhancing the EMS to achieve improvements in overall environmental performance' (Tibor and Feldman, 1997).

Comparing Responsible Care® with ISO 14001, one concludes that ISO 14001 is more industry specific, because the twenty-two management practices listed in Responsible Care® go beyond the requirements listed in ISO 14001 (Lamprecht, 1996). There are strong similarities in both structure and purpose between the ISO 14001 EMS standard and the Responsible Care Pollution Prevention Code. Both require senior management commitment, a planning process, including prioritization and goal setting, implementation and continuous improvement, measurement of progress, periodic evaluation of practices, and control of critical operations (Tansey and Worsley, 1995).

Comparing ISO 14001 and CERES principles

Founded in 1989, the Coalition for Environmentally Responsible Economies (CERES) is a non-profit membership organization comprised of leading social investment professionals, environmental groups, religious organizations, public pension trustees and public interest groups. The CERES Principles, released in 1989 as the Valdez Principles:

represent a comprehensive ten-point environmental ethic devised to encourage the development of programs to prevent environmental degradation, assist corporations in setting policy, and enable investors to make informed decisions regarding environmental issues (Tansey and Worsley, 1995).

Although most companies attempt to answer the ninety-one questions that make up the CERES Report, some companies simply submit a brief incomplete report, while others seem to rush through the report. This lack of consistency is partly due to the fact

that the CERES Report (similar to ISO 14001 and other international standards) seems to focus on large companies, particularly chemical or petrochemical corporations, already experienced in how to deal with the EPA (Environmental Protection Agency) and OSHA (Occupational Safety and Health Administration) regulations, whereas smaller businesses have to struggle with many of the questions (Lamprecht, 1996).

These Principles aimed at establishing an ethic with criteria which enable the investors and others effectively to assess the environmental performance of companies. Companies that endorse these principles pledge to go voluntarily beyond the requirements of the law (Tansey and Worsley, 1995). Still, when one compares the ISO 14001 standard with the CERES Principles, obvious differences in emphasis quickly become apparent. ISO 14001 is an environmental management system. The CERES Principles, by contrast, recognize the importance of management and 'principles' thus differentiating it from ISO 14001. The CERES Principles emphasize the need for corporations to protect the earth and act responsibly toward the environment in order to allow 'future generations to sustain themselves', while the ISO 14001 standard is more business-friendly and constitutes a compromise document properly written not to alienate the business community. Although ISO 14001 will most likely not satisfy environmentalists, it is a good first step in the right direction toward helping companies throughout the world to begin considering environmental issues (Lamprecht, 1996).

Comparing ISO 14001 and Eco-Management and Audit Scheme (EMAS)

ISO 14000 was developed in the context of other EMS initiatives, such as the BS 7750 EMS standard and the European Union's Eco-Management and Audit Scheme regulation (EMAS) (Demetrakes, 1996). Adherence to a formal EMS and auditing procedure is mandatory under EMAS. EMAS also requires organizations to make independent verifiable statements regarding their environmental performance. Participation in the program entitles a company to register a site in an EU-authorized list of participating sites and to use an EU-approved statement of participation and graphic to publicize its inclusion in the program.

The specific objectives of EMAS can be summarized as follows:

- To promote continuous improvements in environmental performance (EP) by establishing policies, programs and management systems
- To perform systematic, objective and periodic evaluation of these elements, i.e. maintenance of the system
- To provide information related to these activities to the public (Tansey and Worsley, 1995).

Furthermore, the EMAS regulation also requires an organization to communicate its objectives and targets to the public and, occasionally, to disclose the organization's progress, including successes and failures, in meeting these objectives and targets. Thus, the public can view a company's goals for pollution prevention and can exert pressure on those companies which have less aggressive goals or do not meet their objectives and targets (Giese, 1996).

The most obvious difference is that EMAS falls into a category of voluntary regulation, while ISO 14001 is a fully-fledged international standard. EMAS applies only to sites within the EU, whereas ISO 14001 is applicable worldwide. Other key differences include the following (Tansey and Worsley, 1995; Cascio, 1996):

- EMAS is site-specific and relates to industrial activities, whereas ISO 14001 applies to activities, products and services across all sectors, including non-industrial entities such as government.
- EMAS requires an extensive initial environmental review as part of the EMS while this is not specifically required in ISO 14001, but is suggested in Annex A.3.1 of ISO 14001.
- EMAS requires the publication of a validated public environmental statement and an annual simplified statement, whereas ISO 14001 does not require a public statement. In fact, it is up to the company to decide what information to communicate. Furthermore, while EMAS requires the company to publicize its policies, programs and EMS system, ISO 14001 only requires that the EP is available to the public.
- EMAS demands more extensive and rigorous auditing than ISO 14001, which only requires EMS auditing (although the organization under ISO 14001 must evaluate compliance within its requirements).

The EMS requirements in EMAS require the preparation of an environmental effects register contrary to ISO 14001 (Lamprecht, 1996).

Comparing ISO 9000 and ISO 14000

The ISO 14001 (EMS) standard and the companion guideline are believed to have evolved as a natural adjunct to the ISO 9000 series of quality management systems (QMS). While there was an attempt to model the EMS after the QMS, environmental experts saw a need to depart significantly from this standard, primarily in terms of specific requirements. Although integration of ISO 14000 with ISO 9000 has many advantages (Tansey and Worsley, 1995), there are also several major differences between quality management and environmental management that impede total correspondence between the two standards. For instance, whereas quality standards affect an organization and its customers, environmental standards primarily affect an organization's relationship to its neighbors, nearby creatures and ecologies. In addition, unlike the quality field, the environmental field has been on several cases of confrontation, burdened with political exploitation. If one fails to attain quality levels, it is normally not subject to civil and criminal sanctions, the one who transgresses the environmental laws clearly is. Therefore, dissimilarities are bound to exist between elements of the quality and the environmental management standards (Haklik, 1998). ISO 14000 was considerably influenced by the ISO 9000, BS 7750 and EMAS regulations before it emerged as the international quality management standard. Rapid implementation has occurred in sectors like chemicals and electronics. ISO 9000 registration has been strongly leveraged by customer/supplier relationships because ISO 9000 is market-driven; ISO 9000 companies require their suppliers to become certified. This chain of commerce linkage is a highly compelling factor for companies to

proceed and it is believed that there is sufficient ISO 9000 momentum for a natural carry-through into ISO 14000 (Giese, 1996). A comparison of the two standards is given in Table 2.4 (Tansey and Worsley, 1995; Haklik, 1998).

Structure and technology

Three documents in the ISO 9000 series are classified as *requirement documents*, since they lay down the requirements for an organization that wants to be registered. These standards in the ISO 9000 series are:

- ISO 9001. Model for quality assurance in design/development, production, installation and servicing
- ISO 9004. Model for quality assurance in final inspection and test.

The equivalent to these standards in ISO 14001 is known as the *specification document* because it provides the specifications for an EMS. An organization must meet these specifications if it wants to be registered. Both the ISO 9000 and the ISO 14000

Table 2.4 Comparison of ISO 9000 and ISO 14000

	ISO 9000	ISO 14000
Aims	Providing suppliers a means for demonstrating to customers the achievement of requirements for quality. Enhancing the overall performance of a supplier organization in relation to quality	Providing organizations with the elements of an EM: providing assistance to organizations regarding the implementation/improvement of an EMS, including advice on how to meet environmental performance expectations
Structure	Management activities, process requirements and verification requirements; separate guidance standard	Adherence to 'plan-do-check-act' business model
Environmental aspects	The supplier shall define and document how the requirements for quality will be met in order to address customer quality specifications	Addressing the need to identify all environmental aspects of activities, products or services
Contents	Both ISO 9000 and ISO 14000 contain elements of management commitment and responsibility, management system documentation, document control, operational control, training, monitoring and measurement, non-conformance and corrective action, records and audits ISO 9001 includes discrete elements of quality planning, product identification and tractability, and statistical techniques	ISO 14001 includes discrete elements of environmental aspects, legal requirements, objectives and targets, EM program, communications and emergency preparedness and response

Cascio, 1996; Tibor and Worsley, 1997

documents provide the same type of architecture even though the terminology differs. While both systems share the same concept of targets and tolerances, they strongly differ in the variability of demands placed on the systems. In quality systems, a strong line of communication is established between customer and supplier. The registration systems provide assurance to customers that systems are in place to respond to customer needs (Tropea, 1997).

Some components of the ISO 14000 series, such as environmental labeling and life cycle assessment, as well as the environmental performance evaluation guideline documents have no parallel in the ISO 9000 standards. While some correlation in the numbering system can be found, a one-to-one correspondence between document numbers and content does not exist.

Auditing

Auditing is a common denominator of both ISO 9000 and ISO 14000 standards. Although there are some similarities between the two corresponding documents (i.e. use of the verb *should*), in general, the documents differ markedly. The ISO 9000 auditing documents are ISO 10011-1, which is the guideline for auditing quality systems; ISO 10011-2, which includes the qualification criteria for quality system assessors; and ISO 10011-3, a procedure for management of assessment programs. Moreover, ISO Guide 48 specifies guidelines for third-party assessment and registration of a supplier's quality system (Haklik, 1998).

Similarly to ISO 9000, ISO 14000 mandates auditing to ensure that standard requirements are being met. Guidelines for these audits and qualification guidelines for auditors are provided in ISO 14010, 14011/1 and 14012. Audits may be performed internally by trained individuals within the company or by external auditors (Demetrakes, 1996). EMS auditors will also need experience and background in evaluating a system's ability to identify all environmental aspects, significant impacts and risk level of processes (Tansey and Worsley, 1995).

Documentation

Record management systems must be independently developed to meet a variety of internal and external stakeholder needs. Record management under the EMS standard must take into account the issue of liability and compliance with environmental regulations. Recent initiatives, such as privileged legislation in many states and the new EPA audit policy, enable organizations to establish more liberal record keeping programs. There is no apparent description on the quality of records in terms of what records should be kept or how long they should be maintained (Tropea, 1997).

One of the strongest aspects of the ISO 9000 management model is the requirement for sound, comprehensive and controlled documentation. This model, which requires documentation for major elements of the quality system, is also included in the ISO 14000 standards. Record management, document control, documented procedures and training records must all be part of the EMS (Tansey and Worsley, 1995). The comparison of requirements among major codes of environmental management practice is presented in Table 2.5 (Tansey and Worsley, 1995; Lamprecht, 1996; Haklik, 1998).

Table 2.5 Comparison of requirements as stated by major codes in environmental management practices

Requirements	ISO 14001	BS 7750	EMAS	Responsible Care®	CERES	Keidahren Charter
Continuous improvement	Environmental policy must 'include commitment to continuous improvement' to the EMS	Environmental policy must commit to continuous improvement of EP quantifiable, in terms of environmental goals and targets	Commit to 'reasonable continuous improvement' of EP reducing environmental impacts to levels not exceeding those of EVABAT	Continuous improvement required explicitly in pollution prevention and product stewardship codes	Constantly 'update practices in light of advances in technology and new understandings in environmental science'. Aiming at eliminating the release of any substances that may cause environmental damage	Not addressed
Assessment of environmental impacts	'Establish and maintain a procedure to identify the significance of environmental aspects of activities, products and services. Workers must be aware of their personal contribution to environment	Develop a system to identify, examine and evaluate and record the environmental effects, direct and indirect, of its activities	Produce an environmental statement including 'an assessment of all environmental issues' and a report on pollution, use of resources and other environment related activities for public distribution	Several codes require 'regular evaluations of risks'. Pollution prevention codes require 'quantitative inventory of waste'	Not addressed in principles although data on chemical use, waste generation, and resource consumption are required for CERES report	'All company activities shall be scientifically evaluated for their impact on the environment'
Pollution prevention	'Commitment to prevention of pollution' including pollution control	Refers to Annex and to Standard as a corporate policy commitment	Take 'measures to prevent/eliminate pollution or to reduce pollutant emissions and waste generation by using clean technologies'	'Ongoing reduction in waste and releases, is related to source reduction, to recycle/reuse and to treatment'	'Reduce and where possible eliminate waste' through source reduction and recycling	'Employees must be educated to ensure prevention of pollution and energy conservation'
Environmental conduct of suppliers, distributors, customers	'Communicate relevant performance'	Only environmental policy must be made public; communications must be considered, but what else is to be communicated is up to the management	A description of the environmental policy, program with factual data and management system must be available to the public	Everyone affected by conditions caused by the company that endanger health, safety of the environment should be informed in a timely manner. The company will seek advice and counsel with persons in communities near its facilities. The company will not take action against employees for reporting dangerous incidents	'Inform customers about the environmental impacts of its products or services and try to correct unsafe use'	Purchase environmentally friendly products. It will 'provide users with information on appropriate use and disposal including recycling of their products'

Applications of ISO 14000

Applications to the food industry

As with the ISO 9000 standards, the food industry has lagged behind other businesses in implementing the ISO 14000 series. Chemical and automobile companies have been the most active participants in ISO 14000 development. The main environmental challenges of food companies could be summarized as follows: water availability, wastewater discharge, air emissions, by-product disposal or utilization, chemical residues, solid waste disposal and food packaging materials. Ensuring a safe food supply requires prolonged shelf-life of a food product and choice of appropriate packaging material which may constitute a critical disposal problem (Stauffer, 1997). Another challenge facing many food processors is the need to separate and dewater solids from wastewater, thus enhancing both the environmental protection and the profitability of the enterprise. The question regarding the best equipment (screen, presses or centrifuges) for removing waste out of water and then water out of waste should be examined case by case (<http://www.scc.ca.uk/iso14000/>).

However, food companies have already recorded significant environmental achievements. The 1995 annual report for Anheuser-Busch disclosed that, under a company-sponsored program, the volume of recycled aluminum beverage cans tripled over the previous 10 years. The report goes on to describe the company's Biological Energy Recovery System in terms of digesting organic matter in brewing wastewater to convert it to methane gas which is used as fuel in the brewery's boilers (Begley, 1997). The 1998 Unilever Environment report commented on the progress that has been made in all fields of environmental preservation, such as the integration of warehouse and transport arrangements in the frozen food business to save noise, congestion, fuel and emissions both for European and non-European ISO 14001 certified food industries (Biggs and Nestel, 1995; Propper, 1998).

Kellogg was one of the few cereal companies employing recycled material in its packaging. On the company's box of Mueslix breakfast cereal, the following statement is stamped next to the recycle symbol with chasing arrows: 'Carton made from 100% recycled paper, minimum 35% post-consumer content', indicating the concern of food processors for environmental issues (Stauffer, 1997).

ISO 14000 standards are important to food companies and will hopefully be implemented much faster than ISO 9000 because they directly affect issues that can only become more important in the future. Various food industry management problems, such as processing wastewater and packaging issues, are likely to be solved through ISO 14000. Laboratories working on this implementation will most likely be strongly encouraged to register to ISO 14000 standards in order to enhance their business opportunities by performing life cycle assessments among other tests (Giese, 1996).

Implementation of a structured management system will ensure that an organization and its facilities not only meet (as is suggested by environmental reviews or audits) but also will continue to meet environmental objectives. Such a system will function only with the commitment of all employees beginning at the highest level of management and the need for training, awareness for implementation and maintenance of ISO 14000 should be anticipated (Propper, 1998).

Applications to the chemical companies

Companies already having a strict EMS in place may find ISO 14000 a non-demanding and superficial system, according to one, containing elements that 'any reasonable competent environmental system should have'. The decision to follow ISO 14000 standards will ultimately come down to costs versus benefits. International consistency in environmental management, especially as multinational companies expand manufacturing and marketing overseas, is a leading advantage advocated by chemical industry environment, safety and health (ESH) managers. Uniform standards are anticipated to minimize confusion and levy trade barriers. It is widely believed that certification of a company's EMS by an international recognized registrar may reinforce the standards' impact with outside interests and governments (Shirley, 1997).

Many hydrocarbon processing companies ponder whether or not to invest their time and resources in attaining ISO 14000 accreditation. Similarly to ISO 9000, ISO 14000 is a verification process assuring that the operating company is continuously struggling to achieve its environmental goals and policies. The standards broadly define that organizations should develop an EMS as the infrastructure to customize procedures and guidelines. Although adopting EMS is no guarantee that environmental performance will improve, EMS can considerably enhance the company's chance of achieving better performance. Besides the marketing advantages, EMS can install an environmental culture, thus inducing employees to adopt a work attitude that can result in improved EP (Fredericks and McCallum, 1995).

The answer to whether ISO 14001 establishes EP requirements is negative because the standard was written to be applicable to all organizations irrespectively of type and size in diverse geographical, cultural, social and economic situations. In fact, it seeks to balance socio-economic and business needs with support of pollution prevention. Although ISO 14001 does not establish absolute EP requirements, the standard does contain requirements that should result in a higher and steadily improving performance level (Hunt and Johnson, 1995). ISO 14000 certification will require investment in software, manpower, equipment installation and possible third-party auditing (Carawan, 1995).

Applications to forestry and agriculture

Forestry sector delegates who attended the International Standards Organizations' Environmental Committee (TC 207) in Rio de Janeiro said that they were delighted with the decision to establish a formal ISO Working Group with the task of preparing informative reference material to assist forest organizations in their use of the ISO Environmental Management Standards (Romanow-Gaecia, 1996).

Implementation of these ISO standards and practices encouraged better forestry practice worldwide. Forestry management involves a most complex matrix of environmental, social and economic issues. The ISO standards and processes improved the understanding of these complex global issues and offered a practical framework for implementation at local level (Shirley, 1997).

Dutch trade/industry delegates to international forums have continued to put forward concrete suggestions for implementing an ISO-14000 based system of certification and supported Canadian efforts in this area. Continuing pressure from ENGOs on target groups such as 'do-it-yourself' retailers and municipalities to limit use of tropical timber to certify sustainable products resulted in an aggressive press campaign. Since the influential 'Heart for Wood' campaign has been extended to cover all timber, not solely tropical products, it becomes increasingly important for temperate producers to develop systems that certify sustainable production and are compatible with the Dutch industry-led hallmarking system (Shirley, 1997).

The Monsanto Corporation is one of the world's largest producers of chemicals and pesticides for agricultural and home use. Monsanto recently stated that sustainable development is the company's fundamental business strategy because this is the only way to ensure the continuation of the company's operations in the long run. Seven sustainability teams are currently working toward developing methods, processes and systems integrating sustainable development into the operations of Monsanto.

Stakeholder management is a central activity within any environmental strategy. Increasingly, business leaders around the world are recognizing the importance of developing an environmental strategy that supports sustainable development and integrates stakeholders' issues, concerns and requirements. The ISO 14001 standard for EMS offers a set of practical and certifiable tools to implement stakeholder management processes and to support a sustainable global economy.

ISO 14000 and banks

The ability to adjust banking credit and investment practices to reflect environmental factors may depend on a bank's ability to obtain and use accurate and reliable environmental information. An opportunity for expanding the information base on the environmental performance of industrial entities may arise with the advent of ISO 14000.

The ISO 14001 initiative could play a meaningful role in helping debt issuers to evaluate the environmental risk on a pre-commitment and, to a lesser extent, post-commitment monitoring basis. The emphasis on ISO 14001 compliance (non-compliance) information could be integrated into current environmental due diligent processes on any form of credit, as it pertains to any plant and/or equipment extension of credit. As to the exact role ISO 14000 might play, one should realize the bankers' need for consistent and comparable data that allows them to compare similar types of financing transactions.

Through compliance with the ISO standard, firms can demonstrate that they have a specific plan to reduce environmental pollution and are incorporating environmental management into the overall management of the organization. The banking industry's interest will depend on how the bankers perceive a connection between this certification and the actual reductions in financial risk. This connection will clearly depend on the quality of external information that emanates from the ISO 14001 process, which is still under development (Murray *et al.*, 1997).

ISO 14000 and governments/education

An experiment was carried out by an informal consortium of 10 states in the USA to determine how beneficial EMS are for the environment and economy. The group is made up of several state regulator representatives from EPA, the National Institute of Standards and Technology, the University of North Carolina, Tulane Law School, the Environmental Law Institute and a Washington, DC-based law firm. This group developed a set of peer-reviewed criteria to measure the environmental and economic results of using a voluntary ISO 14000-based EMS. The common research methodology was designed to produce comparable results between different states (Begley, 1997).

This study covered a wide range of industries, from a military base to potato farms to manufacturing and process industries, including automobile and equipment manufacturers as well as metal coating and finishing plant. The long-term objective of these pilot projects was to gain insight into the changes of a firms' environmental and economic performances and to see whether they will be cleaner or achieve the same degree of performance more efficiently.

Workshops with business community and other interested groups looking at issues related to the use of ISO 14000 have been sponsored. They provide guidance on how inspection policies should change for organizations adopting the standards, how small companies could be included in the program, how to deal with community concerns about the perception of less enforcement for companies committed to this approach and what laws and regulations should be changed to accommodate the ISO 14000 system. The first result of these workshops was the proposed policy to encourage the use of environmental compliance systems and voluntary compliance audits. According to this proposal, companies that conduct compliance audits or follow ISO 14000 standards will not be subjected to fines or penalties for violations they uncover, as long as the violations are reported and promptly corrected (Seif, 1997).

Indonesia had been planning to adopt ISO 14001 as its national EMS standard, following the example of other countries. The ISO EMS and environmental auditing standards were scheduled for adoption as Indonesian standards in the first quarter of 1997 when a formal accreditation system would be launched. BAPEDAL, the government agency appointed by DSN to lead environmental standardization, held an ISO 14001 conference in Central Java. Several companies present stated their intention to implement ISO 14001 and seek certification, with exporters and foreign-owned companies showing the most interest (<http://www.cutter.com/iso14000/>).

Survey results showed that companies in the USA, Canada and the UK have a strong interest in EMS activities but are not racing toward certification. The majority of USA companies surveyed wanted to learn about what their customers are demanding, what their competitors are doing and what is going on in the foreign marketplace prior to initiating such activities. They were aware that Europe and the Pacific Rim countries were far ahead of the USA in adopting voluntary standards. Both ISO 9001 and ISO 14001 were applied in public and private universities both in developed and developing countries in an attempt to show clearly their compliance with quality assurance and environmental management.

ISO 14001 implementation

Introduction

All EMS components should be coordinated with other important functions of the organization, the policies, objectives and targets of the finance, operations and safety departments and, if possible, compatibility with those of the environmental department (Kuhre, 1995).

If an organization is already ISO 9000 certified, considerable time can be saved because the following materials, already prepared for ISO 9000 certification, can be used for ISO 14000 with only minor changes: organization and personnel procedures, records and controls of documents, audits and reviews. Although several other sections from ISO 9000 documents can be also used as a starting point, further modification is required (i.e. procurement section) to bring them up to ISO 14000 standards (Rothery, 1993).

TC 207's strategies for implementation of its standards could be classified into three stages: building confidence in the standards by ensuring consistent interpretation and mutual recognition between jurisdictions; promoting acceptance of the standards among users; and monitoring the effectiveness of the standards. TC 207 wants to ensure that the ISO 14000 EM standards are used and interpreted appropriately. To that end, it is working to provide consistent information on them, guided by its Communication Plan. Since the standards are both voluntary and widely available, it is up to the standards organizations, governments and conformity assessment bodies to ensure that they are correctly employing them, based on the information provided by the TC and its member organizations. TC 207 also cooperates with ISO and other working bodies to ensure that certification/registration structures worldwide are consistent and broadly recognized (Barg, 1996). In Figure 2.4, the EM cycle for a glass industry is given and, in Figure 2.5, the implementation diagram of ISO 14001 is shown (Tansey and Worsley, 1995; Ammenberg and Hjelm, 2002).

Initial assessment and definition of purpose

Before an organization begins planning and implementing the ISO 14001, an initial assessment should be carried out. This will help identify the most critical needs for new environmental systems. However, if most major systems have already been in place, then the initial assessment is not required for certification. The definition of purpose should be made in conjunction with initial assessment. The purpose could consist of better environment protection and that the ISO 14000 certified factory could become more cost-effective and would improve community relations and market appeal (<http://www.scc.ca/iso14000/infobref.html>).

Policy preparation

The policy must reflect the organization's commitment to comply with environment-related applicable laws and regulations. ISO 14001 registration complements compliance

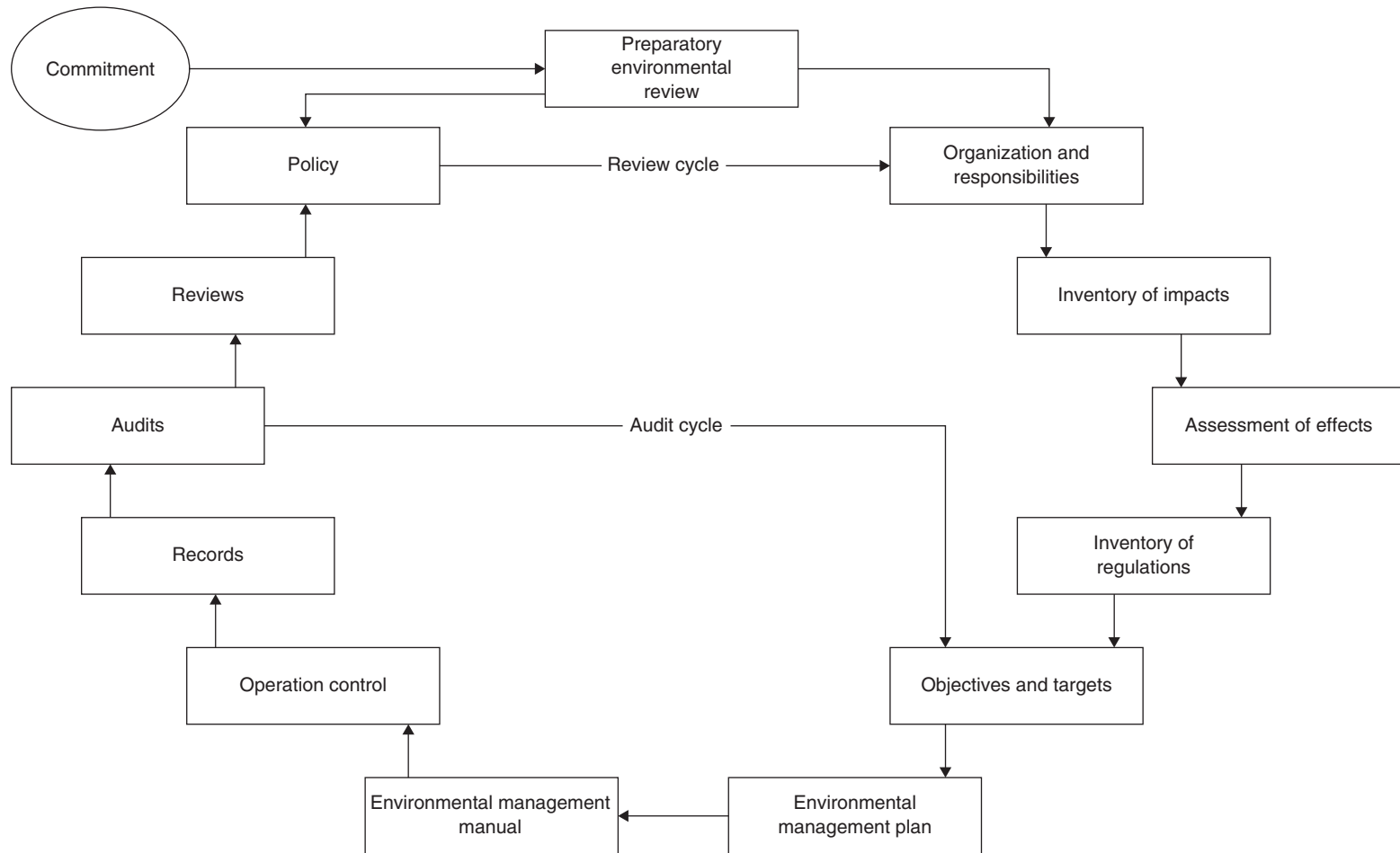

Figure 2.4 The environmental management cycle (adapted from Tansey and Worsley, 1995; Ammenberg and Hjelm, 2002)

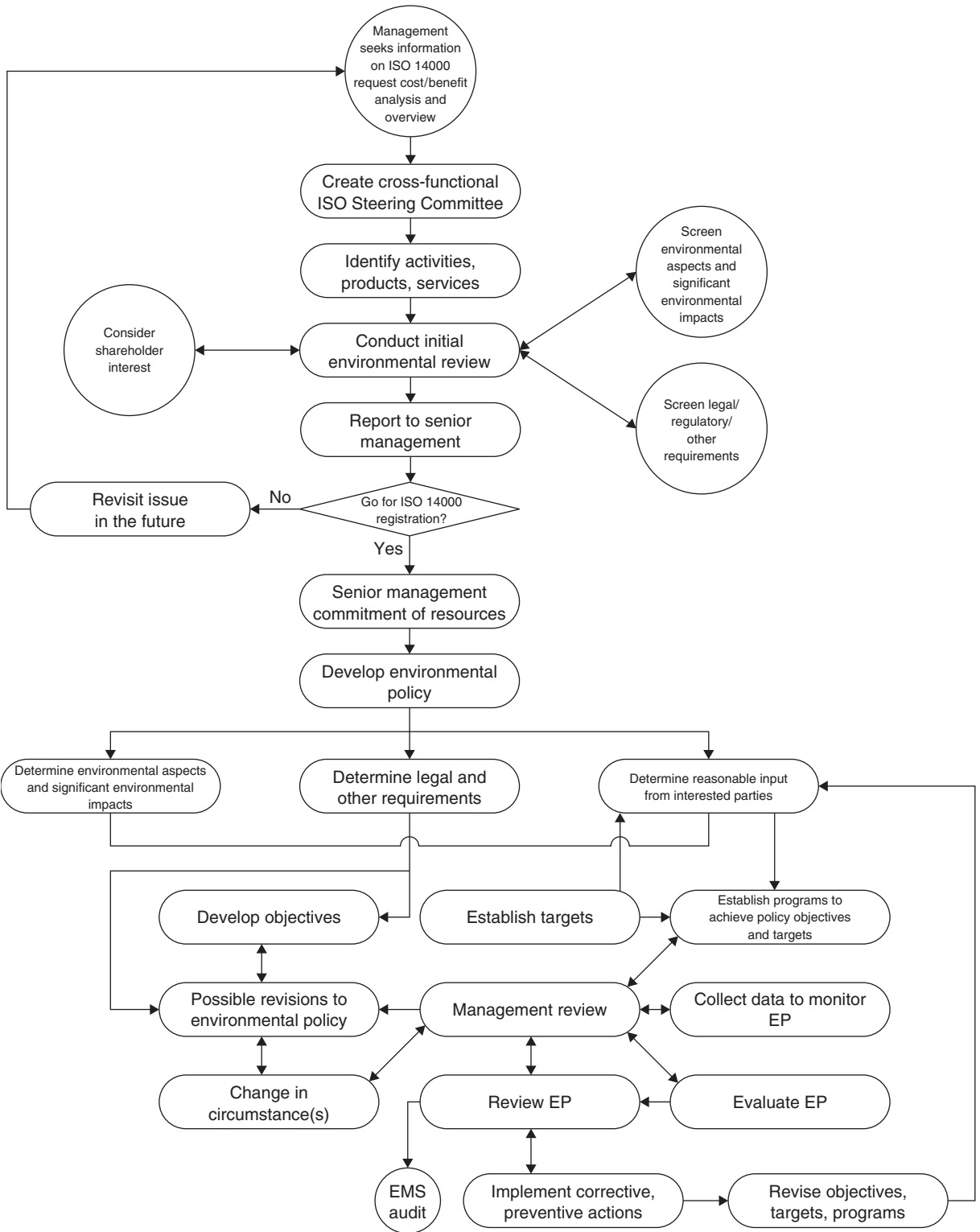

Figure 2.5 Typical ISO 14000 implementation diagram for an organization/company (adapted from Zeng *et al.* (2005); Ammenberg and Hjelm, 2002)

with national laws and regulations (Tibor and Feldman, 1997). The policy's role is to address impacts and regulations in a broad sense and should be supported by senior management and communicated to all employees and public. The policy preparation is due to start at the early stages in the process and should be continuously upgraded. Even if the policy is only roughed out at this point, it will at least provide overall direction to the process when it is especially needed. A rough draft of the policy should be widely circulated for upgrades and input from as many employees as possible. This will increase acceptance to the maximum possible extent.

Objectives and targets

Objectives and targets should be set in order to adhere to the policy statement. The objections should include statements such as establishment of a waste minimization program. Targets would be specified for each objective and numerical goal (i.e. 10 tons of acetone waste to be recycled by the end of 1999). As with the policy statement, the objective and target preparation should start as early as possible and be continuously upgraded (<http://www.scc.ca/iso14000/infobref.html>). Specific and measurable environmental targets should be set to achieve the objectives within a specified time-frame. Measurements are recorded in the form of environmental performance indicators (EPI) such as quantity of raw material or energy used, quantity of a specific compound emitted, waste produced per quantity of finished product, percent recycled, or number of environmental incidents/accidents (Tansey and Worsley, 1995).

EMS documentation and utilization of existing documents and resources

Many companies reported that the EMS had led to improved procedures and documentation. This reported benefit is interesting because most organizations considering the implementation of EMS complained about the level of required documentation in ISO 14001. One explanation for this seemingly surprising discrepancy is that organizations acknowledge documentation and written procedures but they are not positively disposed to fulfill the standard requirements regarding what should or should not be documented (Rothery, 1993). If documents already exist for other programs (environmental and quality systems) that address some of the ISO 14000 considerations, they should be utilized. For example, many ISO 9000 documents and systems, such as training, could be used as they are or with very little adaptation since there are many common links or elements (<http://www.scc.ca/iso14000/infobref.html>). In Clause 4.4.4, ISO requires the preparation and maintenance, in paper or electronic form, of the following terms:

- Description of the core elements of the management system and their interactions
- Providing direction to related documentation

- Creating, using and maintaining written documentation and allowing an evaluation of current conditions and procedures and assessment of current performance is central to the effectiveness of EMS implementation (Tansey and Worsley, 1995)
- Preparation of new operation procedures and action plans.

After completion of the above steps, the new missing procedures will be prepared. Many EMS are often composed of unwritten procedures and standards, thereby leading to confusion, lack of direction and negative environmental impacts. It is necessary to put in writing any environmental control action so that questions can be answered about what was done. An environmental management manual(s) should be set up to include all procedures and standards. It should also contain a copy of the company policy.

Implementation of programs

Far too often, organizations only write and talk about environmental protection. The EMS needs to be implemented actually to protect the environment. Although this may seem obvious, in real-life, administrative delays, apathy and inadequate personnel and training can prevent environmental protection and improvement from happening. A good top management policy, energetically pursued, will assure success. The bottom line is that certification will require implementation in addition to the preparation of procedures and documents (Kuhre, 1995). An example of a registration process could be the following:

- Application/contract. Determination of the scope of registration, location and number of facilities and employees to be audited.
- Pre-audit option. Readiness of the new EMS for a pre-audit.
- Documentation review. Readiness of the organization for a formal audit.
- Certification assessment. Compliance of the EMS system with ISO 14001 standard requirements.
- Certification. Independent review will issue the ISO 14000 certificate.
- Certification maintenance (surveillance). Annual surveillance visits maintain the integrity of the established EMS (Rothery, 1993).

The time required to implement an EMS depends on the company's current status, its commitment to the process and allocation of resources. Although it can take some companies as little as six months, on average it takes slightly longer than a year to prepare for a first registration assessment (Hunt and Johnson, 1995).

Ongoing auditing, management reviews, correction and follow-up

The audits, reviews, correction and follow-up will result in continuous improvement of the EMS. It is always possible to improve the quality of the environmental controls with a net positive impact on the organization and the working and surrounding environment.

Certification

TC 207 promotes integration and certification of ISO 14000 with ISO 9000 through a coordinating committee (TC 176/TC 207). Integration is recommended in view of their relationship and their mutual complement. Integration, however, could result in loss of certification for both if one is not up to standard.

Continual improvement

By carrying out routine internal audits and monitoring, it will become evident that the policy, objectives, targets and plans will eventually have to be modified. Frequent upgrading of the entire system will keep it cost-effective and impacts will be reduced (<http://www.scc.ca/iso14000/infobref.html>). Registration is also considered by some companies as a potential way to demonstrate EP to customers and other stakeholders including regulators, insurance companies and community groups (Rothery, 1993).

ISO 14010 – Environmental auditing

Objectives or purposes of an environmental audit – general

Environmental audits, while originally intended to ensure regulatory compliance, have expanded in scope and purpose to include evaluations of management systems and risk assessments of unregulated activities (Diamond, 1996; <http://www.us.tuv.com/>). An environmental audit is a systematic process destined to obtain, evaluate and report facts concerning conformance with criteria, thus making meaningful improvements that will minimize negative impacts to the environment and employee safety (Kuhre, 1995; Mohamed, 2001).

ISO 14001 certification criteria

Determination of conformance of the EMS of an organization in terms of ISO 14001 certification constitutes a major objective of environmental audits. The emphasis, at least initially, will be on auditing against the ISO 14001-EMS specifications. For example, the auditor will assess whether management review of environmental issues is involved (<http://www.us.tuv.com/>). The audit documents provide the principles and procedures for systematic auditing. Conformance demonstrations have a foundation upon which to assert their credibility. Since part of this foundation is the certified expertise of the people conducting the audits, there is also one standard defining the criteria for auditor qualification (Kuhre, 1995).

Improve regulatory compliance

Another top priority of carrying out audits is to help an organization comply with current regulations. Audits will identify areas that need further improvement in order to

meet the regulations. Once these corrections are made, the organization should be able to demonstrate regulatory compliance. Effective detection of problems and possible violations considerably shorten the period of non-compliance, assuming the appropriate corrective action is undertaken (Mohamed, 2001).

Policies and objectives

The first step in the EMS audit is determining the audit scope, objectives and purpose. The lead auditor, in conjunction with the client, should define why the audit is being performed and what its target is. The lead auditor and the client will jointly determine the required resources, the audit duration and timing. In addition to standards and regulations imposed by external parties, most organizations establish internal policies and goals (General Principles and Practice Guidelines for Environment Auditing, 1998).

Save money

Auditing will help the organization save money by minimizing the monetary fines and by adopting proactive actions such as disposal and cleanup costs reduction (Mohamed, 2001).

Continuous environmental improvement

Continuous environmental improvement is essential for minimizing impact to the ecosystem and for building and maintaining a sound organization. Audits will help the organization continuously upgrade its environmental and safety control systems.

Spot potential problems

Early identification of a potential problem will usually allow correction in a more cost-effective manner. In some cases, if a potential or small problem is resolved early, it may prevent it from becoming a major crisis, which could possibly affect many components of the environment and employee safety. Overall audits help to reduce the risk of accidents when problems are promptly rectified.

EMS implementation and maintenance

The main way an organization can be assured that it is up to the ISO 14001 standards is the environmental audit. Although lack of problems and fines constitute an indication that an EMS is in place, audits would be more reliable and proactive.

Choosing a supplier

An environmental audit is an assessment tool of the environmental consciousness of a potential supplier. The company/organization should not only require its primary

suppliers to protect the environment, but the contractors or vendors of those suppliers as well. Care should be taken that the entire chain of suppliers starting from raw materials to final products does not harm the environment.

Quality control of the sampling and measurement process

An audit should include monitoring frequency, method, equipment used, sample size personnel employed and variation in results. The audit may suggest that sampling be carried out differently or that different variables have to be assessed. According to the Canadian Environmental Association, the audit plan consists of:

- Obtaining background information about the organization and the facilities, systems, or activities to be audited and identifying individuals with significant roles and responsibilities.
- Carrying out a preliminary on-site survey in order to identify aspect/areas of audit risk.
- The systematic application of appropriately designed procedures and methodologies promotes objectivity and reliability in obtaining audit evidence.
- Identifying the resources, such as number and qualifications of auditors and other technical experts that will be needed, depending on the type of audit, the nature and complexity of the subject matter and the assessment of audit risk and to ensure auditor objectivity.
- Consulting with the auditee regarding practical matters such as availability of auditee personnel, records and data, work place health and safety requirements and operating schedules (Kuhre, 1995).

Contractual requirements

Audits can help verify whether the contractual terms and conditions regarding environmental protection or safety are being met in a diligent manner or whether the contract has been breached.

Improving public perception

Companies conducting audits for ISO 14001 certification should carefully plan the audit to protect the company (auditee) from any liabilities. The audit may be conducted only for the purpose of identifying whether a company is willing and able to correct any violations detected during the course of the audit. The company should carefully plan the scope, ensure the confidentiality of the audit and rapidly rectify any violations identified by the audit report (Tibor and Feldman, 1997). Some organizations, especially in Europe, are planning on releasing audit results to the public in an attempt to build public trust and to comply with BS 7750 and EMAS. In the USA, although most companies really do care about public perception, they are not planning on releasing audit results to the public because of fear of litigation (General Principles and Practice Guidelines for Environment Auditing, 1998).

Improvement of management and employee awareness

Auditing can help enhance the environmental awareness of all employees if some of the audit results are shared with several employees. Problems identified must be promptly corrected, especially if the audit results are to be shared with many employees.

Costs of implementation

The generic set of cost attributes involved in implementing ISO 14001 that have been incorporated in the research model are listed below. However, it should be made clear that the level of these attributes varies substantially from company to company, greatly depending both on the scope of registration and the nature of environmental management system in practice.

- Training
- Documentation
- Process modification
- Registration fee (registrar fee, travel and lodging expenses depending on the number of external auditors and the number of days required for the third-party audit)
- Registration maintenance (mainly in terms of staff time)
- Organizational adaptation (roles and responsibilities must be clearly defined and communicated)
- Legal negative consequences which may result from audits, product labeling and liability must be considered when becoming certified
- The third-party review of documents required for ISO 14001 registration could make a company vulnerable to domestic regulatory actions against the company.

Post and Altman (1994) have broadly categorized the barriers experienced by organizations during environmental management process as:

- 1 industrial barriers (for instance technical information, capital costs, configuration of current operations, competitive pressures and industry regulations)
- 2 organizational barriers (for instance employee attitude, poor communication, past practice and inadequate top management leadership).

Brief presentation of new ISO 14001:2004

ISO 14001:2004 was published by ISO on 15 November, 2004 (http://www.iema.net/library/ISO14001_changes/ISO%2014001%20changes.pdf). The IS EN ISO version on the standard was published early in 2005. The publication date when the standard is published as an ISO document is the key date for transition timing (http://www.nsai.ie/News_ans_Events/upload/transition_plan.pdf). The key changes of ISO 14001:2004 include new documents, a documented assessment of environmental impacts,

compliance issues, emergency preparedness and response, non-conformity and management review (<http://www.iosh.co.uk/files/publications/ISO14001update.pdf>).

Primarily, findings which are exclusively against requirements of ISO 14001:2004, will be raised to a category three findings (comments). The transition period ended on 15 May, 2006 at which time certificates to ISO 14001:1996 became invalid and findings against ISO 14001:2004 will be raised as category 1 or 2 (non-conformances). ISO 14001:1996 certificates will now only be issued to have an expiry date of 15 May, 2006 or earlier (http://www.nsai.ie/News_ans_Events/upload/transition_plan.pdf). The details (standard sections, key changes, requirements, EMS, impact financial and compatibility with ISO 9001) of changes of ISO 14001:2004 are given in Table 2.6.

Overview of case studies reported on implementation of ISO 14001

A survey carried out by Zutshi and Sohal (2004) gives a general picture as to the perceptions and experiences of the organizations with respect to EMS implementation. The findings can be briefly summarized in the following points:

- 1 Employees play a significant role in the successful adoption of an EMS. They need to be made aware and trained in the basics and significance of EMS both for the organizations and the employees themselves. The communication and training provided by the organization (especially during the initial stages of the EMS adoption process) both increases employee knowledge and understanding of the EMS process itself and would also assist in reducing their resistance towards the EMS implementation and the changes being made.
- 2 The contributions made by suppliers to an organization's EMS process are still reserved and restricted. Organizations thus need to build trust and long-term relationships with their suppliers to obtain full benefits from their suppliers' involvement during the implementation process.
- 3 Organizations, when calculating the payback period from the EMS implementation, need to understand that not all the benefits from EMS implementation are quantifiable in dollar terms. Moreover, many benefits to be realized are long rather than short term.
- 4 Ambiguity, duplication and wastage reduction of resources are feasible only through integration of their existing management systems and audits with EMS.
- 5 EMS implementation costs would also be reduced if organizations learn from their past experiences of implementing other systems ISO 9000, OHS and from the experiences of other industries in the same field.

The considerable difference reported between the registration rate of ISO 14001 environmental management system (EMS) and the implementation rate of environmental impact assessment (EIA) in the construction industry in Mainland China clearly indicated that

Table 2.6 ISO 14001 comparative table of changes

Standard clause/section	Key change	Requirements	EMS	Impact financial (Euros)	Compatibility with ISO 9001
Definitions	<p>New terms and definitions to increase compatibility with ISO 9001 regarding:</p> <ul style="list-style-type: none"> ● auditor ● continual improvement ● corrective action ● document ● internal audit ● non-conformity ● preventive action ● procedure ● record <p>Revised standard removes definition of EMS Audit</p>	<ul style="list-style-type: none"> ● The definition of <i>auditor</i> has been aligned with the definition in ISO 9000:2000. Organizations will need to demonstrate that their (internal) auditors are competent and auditor competence must be defined in the organization's EMS ● The definition of <i>continual improvement</i> has been amended with an additional emphasis that the process must be a <i>recurring</i> one. The organization must be able to demonstrate that the continual improvement process is recurring and is not a one-off event ● <i>Internal audit</i> has replaced the term Environmental Management System Audit, partly to avoid confusion by users of the standard with external (certification) audits. The wording of the definition has been amended to emphasize that internal audits must be independent. The focus of the internal audit has changed from one of determining conformance of the EMS to determination of conformance with the EMS audit criteria ● The definition of <i>environmental performance</i> has changed in focus from the management system to the organization's management of its environmental aspects. Organizations will need to ensure that the evidence they use to demonstrate environmental performance improvement is in accordance with the revised definition ● The definition of <i>prevention of pollution</i> has been clarified to reflect methods and options for the prevention of pollution. An organization will need to examine how it defines prevention of pollution (and its scope) to ensure that it covers new concepts of 'creation, emission or discharge of any type of pollutant or waste' 	Document only	Nil	High alignment with ISO 9001

(Continued)

Table 2.6 (Continued)

Standard clause/section	Key change	Requirements	EMS	Impact financial (Euros)	Compatibility with ISO 9001
4.1 General requirements and scope	More specific requirements for the organization to clearly define and document the scope of its EMS, continually improve the EMS and to determine how it will fulfill the requirements	<ul style="list-style-type: none"> • The addition of ‘determine how it will fulfill these requirements’ to clause 4.1 requires the organization to state how the EMS fulfills the requirements of ISO 14001. The process will need to be traceable. It will be insufficient to claim that the internal audit cycle covers all clauses of the standard and therefore you are able to demonstrate that the EMS fulfills the requirements of ISO 14001 • Ensure that the scope of the EMS is clearly defined and documented, including what activities, operations, services and products are included within the scope. For organizations seeking accredited certification, the EMS scope must agree with the requirements laid down by accreditation rules. These preclude organizations from ‘ring fencing’ their EMS scope to exclude difficult areas or areas that are part of their site 	Document only	Nil	High alignment with ISO 9001
4.2 Environmental policy	The policy is consistent with the scope of the EMS (i.e. that it covers all activities, products and services within scope). In addition, the standard requires that the policy be communicated to ‘all persons working for or on its behalf’ and not just ‘employees’	<ul style="list-style-type: none"> • To comply with the requirement for the environmental policy to be consistent with the scope of the EMS, the environmental policy must not cover issues that are wider, narrower or different from that of the EMS scope • To demonstrate compliance with the new requirements the environmental policy must: <ul style="list-style-type: none"> - Be developed by top management - Cover the scope of the EMS - Cover all activities, products and services within the scope of the EMS - Reflect the amended terminology with regard to applicable legal and other requirements - Be communicated to everyone working for or on behalf of the organization. This includes contractors, subcontractors, temporary staff and remote workers 	The policy shall not go beyond the scope. On the legislation side it now goes beyond pure environmental legislation. It can include health and safety regulations, for instance, if applicable to environmental aspects. This change also applies to clauses 4.3.2 Legal and other requirements and 4.5.2 Evaluation of compliance	€	Low alignment with ISO 9001

<p>4.3 Planning 4.3.1 Environmental aspects</p>	<p>Revised standard is more specific to:</p> <ul style="list-style-type: none"> ● identify aspects of ‘activities, products and services’ that it can control and those it can influence. Clarifications to ensure no activities, products or services are excluded from aspects assessment. This provides organizations with flexibility to define scope but they cannot include only activities and exclude services and products. It is also implies that the organization will need to consider those it can influence (i.e. aspects relating to goods provided through the supply chain) ● identify aspects for new developments, or new or modified activities, products and services. This is to ensure changes in operations are evaluated appropriately and aspects identified ● consider significant aspects in establishing, implementing and maintaining its EMS. This extends the previous standard requirement which required significant environmental aspects to be considered in developing objectives and targets. Document the information from the identification and evaluation process. Clarifies existing requirement ● clear requirement for the information from the process is documented. Changes clarifies that the intent of an EMS is for identifying and managing significant aspects 	<ul style="list-style-type: none"> ● Activities, products or services have been replaced with activities, products and services within the scope of the organization’s EMS ● The requirement has been changed to those activities, products and services that it can influence. This means there is now a clear requirement to determine those aspects that an organization can influence in addition to those it can control. The procedure for identifying aspects and impacts needs to be revised to ensure that it incorporates activities, products and services that can be influenced within the scope of its EMS ● The aspect identification procedure needs to cover planned or new developments, or new or modified activities, products and services ● Organizations are required to document the whole process of identifying their environmental aspects and determining which are significant 	<p>If products (or services) causing significant environmental aspects were not previously included, this change may cause a more in-depth review of the system</p>	<p>€-€€€</p>	<p>Low alignment with ISO 9001</p>
<p>4.3.2 Legal and other environmental requirements</p>	<p>More specific to:</p> <ul style="list-style-type: none"> ● determine the legal and other requirements relevant to the organization’s environmental aspect, and how these apply 	<ul style="list-style-type: none"> ● The change in the wording of the requirement (in this clause and in Environmental Policy) means that organizations will have to take into account all legal requirements that relate to their environmental aspects. This means that not 	<p>The final output is more complex than a simple list, as is the (hitherto) current practice. As</p>	<p>€-€€€</p>	<p>Low alignment with ISO 9001</p>

(Continued)

Table 2.6 (Continued)

Standard clause/section	Key change	Requirements	EMS	Impact financial (Euros)	Compatibility with ISO 9001
4.3.3 Objectives, targets and program(s)	<ul style="list-style-type: none"> ensure that the environmental legal and other requirements are considered in developing, implementing and maintaining its EMS <p>The changes are to clarify that the organization needs to establish and understand the applicable requirements and not just have access to them. The revised standard eliminates the direct reference to environmental requirements. The purpose of this is to remove the potential for misinterpretation that only those requirements from environmental agencies/bodies are relevant (i.e. requirements from OHandS requirements may contain relevant requirements).</p> <p>The changes also increase the emphasis on compliance by stating that the requirements are taken into account in establishing, implementing and maintaining the EMS</p>	<p>only the directly applicable environmental legislation but also other environmental aspects related legislation e.g. COMAH (Control of Major Hazards and Accidents). Organizations will need to determine <i>how</i> the legal and other requirements apply to their environmental aspects, ensuring that these are reflected in the EMS overall</p>	<p>per the commitment made in the policy (4.2), ‘non-environmental’ legal and other requirements may have to be included</p>	Nil	Medium alignment with ISO 9001
	<p>The requirements of the 1996 Standard Clause 4.3.3 (Objectives and Targets) and 4.3.4 (Environmental Management Program(s)) are now incorporated in Clause 4.3.3 of revised Standard. The structure change is to improve the links between the goal setting and program/planning processes to achieve these goals.</p> <p>The revised standard now requires that objectives and targets are to be</p>	<ul style="list-style-type: none"> Organizations need to demonstrate through the EMS that the objectives are consistent with the above 	Document only	Nil	Medium alignment with ISO 9001

measurable (where practical) and consistent with all the Policy commitments – including those of compliance with legal and other environmental requirements and continual improvement and not just those related to the prevention of pollution.

The changes also require that significant aspects and legal and other requirements must be taken into account rather than just considered in developing objectives and targets

4.4 Implementation and operation

4.4.1 Resources, roles, responsibility and authority

Revised standard requires that resources (provided by management) be provided for establishing, implementing, maintaining and improving the EMS

The revised standard includes the phrase ‘improving the EMS’ in order to strengthen and facilitate the intent of continual improvement. It also includes ‘organizational infrastructure’ as a resource along with human resources

- The revised clause incorporates resources, roles and authority, in addition to responsibility, which need to be reflected in the EMS and documented procedures
- Organizations are now required to ‘ensure the availability’ of resources rather than ‘provide’. This will mean, for example, that organizations will need to demonstrate that there are contingency plans in place to ensure that competent people are able to fulfill specific EMS roles

No significant impacts, but potentially more responsibilities to the management representative when reporting to the top management (see 4.6), including recommendations for improvement

Nil

Medium alignment with ISO 9001

4.4.2 Competence, training and awareness

Any person(s) performing tasks on its behalf that have the potential to cause significant environmental impacts shall be competent. Persons now specifically includes contractors, temporary staff etc. (Note – 1996 Standard refers to ‘Personnel’)

The inclusion of ‘competence’ as the first word in the title increases the emphasis on competence. Other changes are terminology and structure of the clause

- The requirement for competence, training and awareness has been extended to incorporate all persons performing tasks for or on behalf of the organization. The organization will need to review all people working for or on behalf of it to ensure they are competent to fulfill their role in the EMS. Records must be retained by the organization that demonstrate competence (on the basis of education, training or experience) of people performing tasks that have the potential to cause a significant environmental impact
- The organization will need to ensure that all people performing tasks for or on behalf of the organization, which includes contractors, subcontractors, temporary staff and remote

May imply training of subcontractors, salespeople, home-based employees, if not done already. The same change applies to the policy. Competence records were kept in most of the EMS anyway

€-€€

Medium alignment with ISO 9001

(Continued)

Table 2.6 (Continued)

Standard clause/section	Key change	Requirements	EMS	Impact financial (Euros)	Compatibility with ISO 9001
4.4.3 Communication	The revised standard requires that if the organization decides to communicate externally about its significant environmental aspects, it shall document the decision and establish method(s) for the external communication	<p>workers, have had an appropriate assessment for their potential to cause a significant environmental impact and the associated competence required</p> <ul style="list-style-type: none"> • The revised wording in paragraph two allows flexibility for the organization to develop the skills and competence to fulfill EMS functions, rather than simply requiring training • If the organization decides to communicate its environmental aspects it needs to establish methods of communication in its EMS. The decision regarding this matter must be documented by the organization. Most organizations do communicate their environmental aspects: sometimes actively to all the public, e.g. through an environmental report or by the use of an environmental mark/logo on their product; sometimes selectively to people who ask about their performance; sometimes as part of legal requirements, e.g. monitoring returns to environmental regulators. In all these cases the organization will need to establish its methods for communicating. It is probable that only very few organizations do not communicate in some way and hence do not need a method of communication 	Document only – most organizations will prefer to communicate externally than to issue a documented decision not to communicate	Nil-€€	Medium alignment with ISO 9001
4.4.4 Documentation	The title of clause in the revised standard has been amended to documentation. This is to reflect alignment with ISO 9001:2000. The revised standard more specifically identifies the documentation required to be included in the EMS as: <ul style="list-style-type: none"> • Environmental policy, objective and targets 	<ul style="list-style-type: none"> • The organization will be required to demonstrate that the above documents are in place to ensure the effective planning, operation and control of processes which relate to significant environmental aspects. The extended requirements are in accordance with the requirements of ISO 9000:2000 	Potential simplification, but most organizations will need to use documented procedures. However, new documents are required: scope, environmental aspects, decision on external communication,	Nil-€	Medium alignment with ISO 9001

	<ul style="list-style-type: none"> ● Scope of EMS ● Description of main elements of the EMS and their interaction and reference to related documents ● All documents/ records required by the standard ● All documents/records needed to demonstrate the effective planning, operation and control of processes that related to significant aspects 		documenting of information to monitor performance, applicable operational controls and conformity with the organization's environmental objectives and targets. The overall EMS, policy, objectives and targets, responsibilities, and external communication still need to be documented		
4.4.5 Control of documents	<p>The title and clause text of the revised standard have been changed to reflect alignment with ISO 9001:2000</p> <p>The revised standard includes more specific requirements to control documents from external origin/sources which are relevant to the EMS</p> <p>Note: reference to 'documented procedure' in 1996 standard has been replaced with 'procedure'</p>	<ul style="list-style-type: none"> ● Title and wording has been changed to align with ISO 9000:2000 ● The organization will need to demonstrate, in addition to the existing requirements, how documents are approved for adequacy prior to issue and how documents of external origin, such as licences, are identified and their distribution is controlled 	No need to revise documents periodically any more, except for emergencies (see 4.4.7)	Nil	High alignment with ISO 9001
4.4.6 Operational control	The text of the revised standard has been changed for clarification, however, the intent remains the same. The clause now includes the term 'implementation' with respect to procedures to strengthen the intent (for controlling significant aspects and continual improvement)	<ul style="list-style-type: none"> ● No additional requirements 	No significant impacts	Nil	Medium alignment with ISO 9001
4.4.7 Emergency preparedness and response	The revised standard contains an additional specific requirement for the organizations to	<ul style="list-style-type: none"> ● Organizations should check that their existing procedure covers the 'identification of potential emergency situations and 	No significant impacts	Nil	Low alignment with ISO 9001

(Continued)

Table 2.6 (Continued)

Standard clause/section	Key change	Requirements	EMS	Impact financial (Euros)	Compatibility with ISO 9001
	respond to emergencies and mitigate or prevent adverse environmental impacts. The 1996 standard contained requirements for establishing and maintaining, and reviewing and revising procedures, but was not explicit regarding the need to respond	<p>potential accidents that can have an impact on the environment and how it will respond to them'</p> <ul style="list-style-type: none"> ● Procedures must also cover actual emergency situations ● Organizations will also be required to demonstrate that the procedures have been periodically reviewed 			
4.5 Checking 4.5.1 Monitoring and measurements	<p>The revised standard requires 'documenting of information to monitor performance...'. The 1996 standard requirement was 'recording' this information. The revised standard also now requires a procedure to document information required to monitor performance, applicable operation controls and conformity with objectives and targets</p> <p>The intent is to strengthen the monitoring element which is essential for facilitating improvement</p> <p>Note: The 1996 standard to evaluate compliance with applicable environmental legislation and other requirements is separated into its own clause (Clause 4.5.2) – refer below</p>	<ul style="list-style-type: none"> ● Applicable has replaced relevant when referring to operational controls. Organizations will need to update their procedures to reflect this change. 	No significant impacts	Nil	High alignment with ISO 9001
4.5.2 Evaluation of compliance	<p>New clause and most obvious change to revised standard. This clause has been prepared from the last paragraph of 4.5.1 in the 1996 standard version. It requires a procedure for periodically evaluating compliance for both legal environmental requirements</p>	<ul style="list-style-type: none"> ● Organizations will be required to retain records of the periodic evaluation of legal compliance undertaken. Note should be made that this clause requires organizations to undertake an evaluation of compliance against all legal and other requirements and that this will be a pre-requisite of accredited certification. This means that compliance against each 	Can imply a broader exercise to include other requirements. Consequently, if non-compliance is found, financial investment for	€-€€€€	Low alignment with ISO 9001

	<p>and other applicable requirements and that records of the evaluation are kept</p> <p>By including a separate clause covering ‘other requirements’ it emphasizes the increase in scope from purely ‘environmental requirements’ to all ‘other requirements’</p>	<p>and every piece of legislation/regulation relating to an organization’s environmental aspects will need to be evaluated before it can be considered to be in conformity with ISO 14001:2004; it will not be acceptable for organizations to claim that the periodic evaluation will be covered by their internal EMS audit programme at some future date</p>	<p>corrective action may be high</p>		
4.5.3 Non-conformity, corrective and preventive actions	<p>The revised standard clarifies the requirement to have a procedure to:</p> <ul style="list-style-type: none"> investigate and determine causes of actual non-conformity and to take action to prevent recurrence investigate potential non-conformities and assess the need for implementing preventive actions review effectiveness of corrective and preventative actions <p>The definition of ‘non-conformity’ as ‘non-fulfillment of requirement’ increases the scope of what a conformity covers, as this now implies non-compliance is a non-conformity, in addition to failing to meet an EMS requirement</p>	<ul style="list-style-type: none"> Organizations need to review and update their procedures as appropriate and ensure that they incorporate, in particular, the prevention of recurrence of non-conformities and the prevention of potential non-conformities The organization’s processes must also be reviewed to ensure that it evaluates the need for action to prevent non-conformities and implement appropriate actions to avoid their occurrence 	<p>New requirements for identification and investigation of causes of non-conformities. Effective and preventive actions are also required</p>	€-€€	High alignment with ISO 9001
4.5.4 Control of records	<p>The text of revised standard has been rearranged in which the specific records required are no longer listed. Instead the clause contains a requirement to have: ‘Records as necessary to demonstrate conformity to the requirements of its EMS and the Standard’ Records which are required specifically are identified under the relevant clause (including evaluation of compliance, monitoring and measurement)</p>	<ul style="list-style-type: none"> Organizations need to ensure that all records used to support the EMS and the standard demonstrate compliance with the EMS, procedures and results Record retention times are no longer required by the standard, although record retention is still required 	<p>No significant impacts</p>	Nil	High alignment with ISO 9001
4.5.5 Internal audit	<p>The title of the revised standard has been amended to reflect alignment with ISO 9001:2000</p>	<ul style="list-style-type: none"> The organization will need to demonstrate that audits have been planned and an audit program is in place – this may be done 	<p>No significant impacts, except when new auditors</p>	Nil	Medium alignment with ISO 9001

(Continued)

Table 2.6 (Continued)

Standard clause/section	Key change	Requirements	EMS	Impact financial (Euros)	Compatibility with ISO 9001
	<p>The revised standard requires that:</p> <ul style="list-style-type: none"> ● auditors selected are competent to ensure an objective and impartial audit ● the audit program is maintained—i.e. updated if scheduled audits are not conducted as scheduled (i.e. slippage in schedule) or are rescheduled <p>Note: Annex A now refers to ISO 19011:2002 for additional guidance</p>	<p>through the organization's audit procedure</p> <ul style="list-style-type: none"> ● Organizations must also retain records from audits and provision for this must be included in the procedure ● Impartiality and objectiveness of auditors will need to be demonstrated 	<p>have to be trained. 'Independence can be demonstrated by the freedom from responsibility for the activity being audited'; this is particularly important for small and medium-size enterprises (SMEs)</p>		
4.6 Management review	<p>Rewording of the clause to reflect alignment with ISO 9001:2000. The amendment specifies that the review is required to include assessing opportunities for improvement and the need for changes to the system. The revised standard also clearly identifies inputs to and outputs from the management review process. The inputs include:</p> <ul style="list-style-type: none"> ● results of internal audits and evaluation of compliance with legal requirements and with other requirements to which the organization subscribes ● communication(s) from the external interested parties, including complaints ● the environmental performance of the organization ● the extent to which objectives and targets have been met ● status of corrective and preventive actions 	<p>through the organization's audit procedure</p> <ul style="list-style-type: none"> ● The input and output of the management review is now prescribed in detail (as listed above) and each of the identified inputs/outputs will need to be incorporated into the organization's management review processes. Note that the management review is not limited to the list of items and may cover other issues as well as reach decisions and recommendations beyond the listed items but which are of relevance to the EMS ● As with audits, management reviews must be conducted at planned intervals, rather than intervals the organization determines ● Explicitly document decisions from the management review 	<p>New requirements to include a long list of issues in the management review: evaluation of compliance (4.5.2), communication with external parties, environmental performance, status of corrective and preventive actions, follow-up from previous management reviews</p>	€-€€	High alignment with ISO 9001

- follow-up actions from previous management reviews
- changing circumstances including developments in legal and other requirements related to its environmental aspects
- recommendations for improvements

The outputs from the process include decision and actions related to possible changes to any elements of the EMS, including the policy, consistent with the commitment to continual improvement

Annex A

Some of the information/guidance provided for some of the clauses has been improved, including references to ISO 14004 and ISO 19011

http://www.iema.net/library/ISO14001_changes/ISO%2014001%20changes.pdf, http://www.nsai.ie/News_and_Events/upload/transition_plan.pdf,
<http://www.iosh.co.uk/files/publications/ISO14001update.pdf>, <http://www.informintl.com/managesyslinks.html>

there was very little coordination between the implementation of the EIA and the EMS in construction projects in Mainland China, and the EIA practice may not really serve as a tool to promote environmental management (EM) in construction. Since the China Environmental Protection Bureau recently enacted to implement the environmental supervision system in construction project supervision, contractors have to pay greater attention to adopt and implement EM in construction. In this regard, Chen and coworkers (2004) presented an integrative methodology (E+) for dynamic EIA in construction, which integrates various EM approaches with a general EMS process throughout all stages in a construction project. The E+ is expected effectively and efficiently to assist contractors to enhance their environmental performances in China.

Ghisellinia and coworkers (2005) clearly demonstrated the presence of environmental decision traps during the implementation of the ISO 14001 and investigated how the overall environmental performance of certified companies can be affected by these traps. The environmental performance of several Illinois ISO certified companies over time was investigated. Furthermore, three manufacturing plants were visited, interviewed and analyzed to determine the possible correlation between their EMS and the environmental decision biases. Results indicated that even companies seriously committed to fulfillment of the ISO 14001 may still fall in cognitive decision traps. Among the suggested topics deserving further attention in the new version of ISO 14001 are:

- 1 Application of the concept of continuous improvement not only to the management system, but also to the actual environmental performance which requires the establishment of environmental indicators
- 2 The standard should better define possible methods for pollution prevention (material substitution, process efficiency, source reduction and in-plant reusing and recycling, rather than end-of-pipe solutions and off-site recycling)
- 3 Concerning voluntary third-party review and certification, the auditors should have a strong environmental and industrial background enabling them to assess the soundness of the company's environmental programs. They should be familiar with the concept of environmental decision traps and should be able to spot them among the various procedures that characterize the ISO implementation
- 4 The audit process should focus less on the documentation of procedures and more on the actual fulfillment of objectives and targets.

In 2002, Summers-Raines carried out a questionnaire study (131 companies across the world) according to which firms in economically developed countries report fairly high levels of satisfaction with ISO 14001 certification. The four wealthy countries with the largest numbers of responses (Canada, Sweden, the UK and the USA), showed no significant differences in overall satisfaction with ISO 14001. These firms were slightly less satisfied with the ability of ISO 14001 positively to impact their ability to trade. When asked to rate their satisfaction with ISO 14001's impact on their profitability, firms in wealthy countries were slightly less enthusiastic.

However, a number of respondents stated that they did not pursue ISO out of a concern for profits – they chose ISO 14001 due to its ability to improve their environmental performance. For these reasons, it is not surprising that firms reported the highest

levels of satisfaction with ISO 14001's impact on the environment. Developing country firms generally rated their satisfaction with ISO 14001 higher than firms in wealthier countries. Open-ended questions and interviews shed some light as to why this is the case. Many firms in developing countries stated that they had no environmental management system in place before ISO 14001. In addition, the relatively low levels of environmental regulation and enforcement have given firms few incentives for environmental protection. Yet, ISO 14001 provided a tool for companies proactively to manage and improve their environmental performance. While managers in economically developed countries were supportive of ISO 14001, it appears that these ideas, tools and practices are less new to them and, therefore, less exciting.

Savely *et al.* (2006) carried out a research study on a statistically relevant sample, resulting in a broad overview of the status of implementation of environmental management systems at colleges and universities in the USA. All 925 institutions were contacted by e-mail and, in conjunction with a follow-up, resulted in 30% response rate. In fact, the number of elements implemented among the 273 institutions ranges from 0 to 16, with a median of 12. Since 47% of the institutions that responded had at least one full-time employee who spends at least forty hours per week on environmental compliance and 55% budgeted annually for environmental improvements, this would indicate that approximately half of the institutions that responded had environmental programs that were well-developed enough to commit substantial time and resources to environmental issues and compliance. The USEPA Region III survey found that 36% of the institutions surveyed had implemented EMS, while during this survey participants indicated that 30% felt that they had implemented an EMS, thus lending support to the credibility of this study. A new methodology known as SOSEA (Strategic Overview of Significant Environmental Aspects) has been designed to identify and rank the significant environmental aspects in sea ports. The main objective of SOSEA is to help port managers to identify significant environmental aspects and to reinforce the awareness about them in order to prioritize work in environmental management. It is based on ISO 14001 vocabulary and requirements and it can be considered as the base for the implementation of any environmental management system for port communities. SOSEA methodology provides evidence of the significant environmental aspects related to port activities. The identification step is therefore important, even if the significance has not yet been established. The knowledge and awareness attainable by going through SOSEA is essential for the future implementation of a certifiable environmental management system (ISO 14001 or EMAS). Furthermore, through a set of key questions, SOSEA helps to assess the specific management status of each SEA, making clear whether and where there is room for improvements and stronger efforts. Finally, the yearly application of SOSEA can provide a snapshot of how significant environmental aspects, and the way they are addressed in practice, evolve (Darbra, 2005). Once the SOSEA procedure was considered complete and ready for evaluation, it was applied to several European ports, each with its own peculiar characteristics. On average, the time required to go through the tool was half a working day, although it varied according to considerations such as port size, experience of port managers and availability of information. As for the difficulty, SOSEA was found to be easily applicable and quite practical, although questions of interpretation were raised when filling in the matrix.

The Self Diagnosis Method (SDM) was developed by two research teams and about sixty sea ports, in an attempt to allow the comparison of the current environmental situation with that corresponding to previous years and the assessment of the opportunities for improvement. It has been designed as a 'first level' tool: it can be applied in approximately six hours by a non-expert user. It is based on the ISO 14001 vocabulary, requirements and structure and can be considered as a first step in the voluntary implementation of an environmental management system for port communities. The specific benefits of SDM are:

- Assessment of port environmental context and management.
- Periodical self-evaluation of the port's environmental improvement.
- Checking compliance with environmental legislation.
- Effective comparison of port environmental performance against a European benchmark.
- Monitoring the quality of current environmental management, to identify points of strength/weakness/opportunity/threat (SWOT) and relevant environmental management gaps.
- Identifying business risk.
- Motivating the port authority towards improved environmental management and raising staff environmental awareness.

Because of similarity and compatibility among the ISO 9001, ISO 14001 and OHSAS 18001 standards, some researchers have advocated an integration of quality, environmental and health and safety management systems in order to improve an organization's performance. Through a structured questionnaire survey, Zeng and coworkers (2006) concluded that the major underlying problems for an enterprise to operate parallel systems include: causing complexity of internal management; lowering management efficiency; incurring cultural incompatibility; causing employee hostility; and increasing management costs. The factors affecting the implementation of IMS are classified into internal and external categories. The internal factors comprise human resources, organizational structure, company culture, and understanding and perception. The external factors consist of technical guidance, certification bodies, stakeholders and customers and institutional environment. Therefore, the effective implementation, operation and maintenance of an IMS is possible provided that companies achieve a multilevel synergy in the implementation of an IMS. In the multilevel synergic model, the strategic synergy should be given the top priority at level 1. At level 2, the organizational structural, resource and cultural synergy play important roles and it is supported by the documentation synergy at level 3 (Figure 2.6). The synergy is beneficial to help ensure continuous improvement of the organization and management systems.

Hillary (2004) has recently compiled a review based on 33 different EMS studies at a UK and EU level dating from 1994 to 1999. Study reports were identified from academic and government sources and corresponding support organizations (Hillary, 1997a). Small and medium-sized enterprises (SMEs) face internal and external barriers when seeking to address their environmental issues and adopt and implement

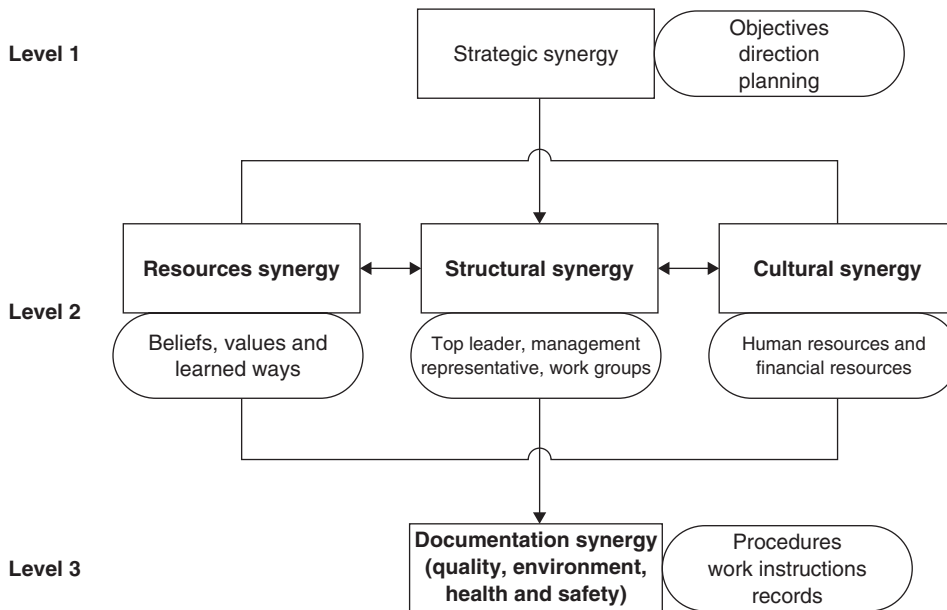

Figure 2.6 Synergetic model (adapted from Zeng *et al.*, 2006)

EMSs, but it is the internal barriers that initially play the most significant role in impeding progress. Negative company culture towards the environment and the disassociation between positive environmental attitudes of personnel and taking action cause the uptake of environmental performance improvements and EMS adoption to stumble at the first hurdle (Mori, 1994). On top of this general culture of inaction on the environment, SMEs are also very skeptical regarding the benefits to be gained from making environmental improvements (Hillary, 1995, 1997b). In many cases, especially for the smaller organizations, low awareness and the absence of pressure from customers (the most important driver for environmental improvements and EMS adoption) work adversely towards addressing the environmental issues. For SMEs it is not so easy to locate good quality advice and information. Once a smaller company has embarked on EMS implementation, the process is often interrupted and resources are frequently diverted to core business activities. It is the lack of human resources (multifunctional staff), not financial ones, which SMEs find most difficult to secure and maintain for EMS implementation, since the process of the latter will be most likely interrupted. Some studies indicated that SMEs, once on the route to certified EMS, face inconsistency and high charges in the certification system and poor quality advice from consultants in conjunction with indifference (towards the adoption of EMS) from the part of the customers. Legislation and the regulators are more important drivers for general environmental improvements in SMEs than customers (Hillary, 2004).

Chen (2005) has recently highlighted the role of ISO 14000 and green purchasing in achieving sustainable development when firms focus on improving both financial

and environmental performance and asserts the importance of the incorporation of green purchasing into the frame of ISO 14000. It was proposed that:

- 1 environmental purchasing is an effective tool in controlling pollution externalities and provides a positive effect on the implementation of ISO 14001 environmental management
- 2 with the incorporation of green purchasing into the framework of ISO 14000, it can encourage firms to implement pollution prevention from the source and to educate the public to engage themselves in green consumption, which leads to the attainments of both environmental and financial performance.

Moreover, a framework of guidelines for green purchasing and the related implementing procedures were presented as well.

Ammenberg and Hjelm (2002) analyzed the environmental performance by comparing the environmental reviews for a group of SMEs before and two years after their EMS implementation. They tried to show how the environmental performance of these firms has developed and draw some conclusions regarding the connection between standardized EMS and environmental performance in general. The case study illuminated some central aspects of ISO 14001's requirement of continual improvement and, in several firms, there were no such proofs (absence of EPIs or non-measurable targets). It is irrefutable that the selection of EPI is crucial. External environmental auditors should compare the development of these indicators and determine whether an improvement has occurred or not. The authors emphasized that an ISO 14001 certificate does not necessarily guarantee good environmental performance. Hence, it is very important to look beyond these certificates and as a customer or consumer require improved environmental performance leading to decreased environmental impact. An EMS is a tool that very well might lead to reduced environmental impact. However, it is critical to focus on environmental impact rather than to focus on implementing a certain tool.

China has undergone rapid changes since adoption of the reform and opening policy in 1978. Meanwhile, China has paid a great cost; e.g. severe environmental deterioration making it one of the most endangered urban and rural environments in the world. In improving the environment, China has taken a number of possible measures including promotion of ISO 14001. To investigate the implementation status of ISO 14001 and its impact on enterprises in China, Zeng *et al.* (2005) conducted a search by means of a structured questionnaire. The results revealed that the major motivation for the system was to seek entrance to the international market. The other benefits were: standardization of environmental management procedures for internal operations; saving resources and reducing wastage for corporate management; improving corporate image (CI) for marketing effects; enhancing environmental awareness of suppliers for supplier relations. Using relative importance analysis, the study identified the critical factors affecting implementation of the standards. The top five out of 27 factors were:

- 1 environmental consciousness of top leaders
- 2 environmental consciousness of middle management

- 3 well-defined responsibility for environmental management
- 4 legal system
- 5 legal enforcement.

Based on the analysis and discussion, the study concluded that the Chinese government should take the lead in improving the legal framework, providing financial support and training to promote ISO 14001 to the Chinese enterprises.

Although the EMS is commonly implemented in private firms, Lozano and Valles (2006) analyzed the consequences of implementing an EMS within the context of local public administrations, particularly regarding the City Council of Ohanes in Almeria (Spain). This was, according to the authors, the first European corporation to implement an EMS according to the ISO 14001 Standard, certified by the Spanish Association of Normalization and Certification. Its analysis would be equivalent to the Shumpeterian 'market innovator study', so that public administration 'followers' can hopefully take advantage of the derived benefits and of minimizing the negative effects of such an experience. On the other hand, it was shown that the economic and environmental advantages derived from the EMS go beyond the activities that the City Council is in charge of. They have spillover effects that extend to all economic activities in the municipality and these effects are expected to increase both in the medium and long-term perspective. Furthermore, a comparison was attempted between the costs and benefits obtained in two cases; the City Council implements the EMS or it does not implement it. It proved that there were considerable economic and environmental advantages obtained by a municipality when it is only the City Council who is implementing an EMS.

Babakri *et al.* (2003) examined the ISO 14001 implementation process using a questionnaire distributed to 584 firms in the USA. The results from the survey indicated that the time to obtain the certificate ranged from 8 to 19 months. In addition, the ISO standard's elements which required the greatest effort and time to implement were 'identifying environmental aspects', 'EMS documentation', 'training', 'EMS audits', 'operational control', 'environmental management program', 'objectives and targets' and 'document control'. Firms seeking ISO 14001 certification should note these time-consuming elements and allocate sufficient resources to them. Moreover, the results of the survey showed that the high cost of certification was the greatest obstacle for ISO 14001 implementation. Lack of available resources was the next greatest obstacle to implementation. The mean scores for the obstacles ranged from 3.57 to 2.53. This suggests that the ISO 14001 certification was not considered by most respondents to be very difficult to obtain. The study provided information on what a firm can expect to encounter during ISO 14001 implementation in terms of the time needed for obtaining the certificate; the most critical ISO 14001 elements in terms of time and effort (identifying environmental aspects, EMS documentation, training and EMS auditing); and obstacles encountered during the ISO 14001 certification process.

A total of 47 firms joined the Swedish EKO-Energi program between 1994 and 1997. This was a public voluntary program devoted to promoting the environmental vanguard, while disregarding the rearguard. The program offered free energy audits

and the promotion of a label, in return for implementation of energy management. Audits covered some 5% of industrial energy consumption. According to Helby (2002), the most clearly observed results were the inclusion of energy efficiency in the environmental policy of participating firms, the dissemination of values and diffusion of pre-existing knowledge within firms and some added impact of such values and knowledge on decisions. The effects of the EKO-Energi contracts could not be disentangled from the effects of simultaneous ISO 14001 or EMAS certification. By the end of 1999, at least 50% of the first 30 participating firms had completed ISO 14001 certification. Twenty percent had completed EMAS certification in addition to the ISO 14001 certification. One firm had EMAS certification without ISO 14001. Uncertified firms included some that were in the terminal phase of certification as well as some that appeared to have abandoned the goal of certification.

In autumn 2000, as part of a postal survey, Emilsson and Hjelm (2002) sent questionnaires to all of the 289 local authorities in Sweden. They were sent to the central environmental managers, or their equivalents, in the local authorities. The survey generated a quite high return rate of 81%. Almost half (107) of the local authority respondents replied that they are implementing EMSs in one or more of their departments and the conclusions were derived from the answers from these 107 authorities. All the questions analyzed in this research were open-ended. It is interesting to note from this survey that decreasing the negative environmental impact is given less priority than organizational changes as reasons for EMS implementation.

Nevertheless, this finding may indicate that many Swedish local authorities already have fairly ambitious environmental goals and are fairly aware of the environmental situation, but their organizations yet do not have the tools or strategies to realize these goals. Therefore, either they might use EMSs to facilitate this procedure or the main reason for EMS implementation could be strategic. If the local authorities obtain a more effective and structured organization, it should enhance environmental improvements because there is more knowledge and control of strategies and actions within the organization. Hence, environmental improvements are the indirect effects of organizational change and restructuring.

A theoretical correlation model was developed by Tien *et al.* (2005) based on various discussions on relevant theories and literature. Tien and his coworkers sent questionnaires to 1200 ISO 14001 certified firms registered with the Taiwan Environmental Management Association and 200 firms qualified for environment standards and registered with the Ministry of Economics, Taiwan. The empirical analysis results on ISO 14001 certified enterprises and firms qualified for environmental protection standards in Taiwan show that the internal motivation for environmental design has a significant effect on environmental design implementation. Communication with related interest groups, continuous education and persistent innovation could all substantially impact environmental design implementation. The better the communication with related interest groups, or the higher the education with environment-related knowledge, the more successful the environmental design implementation. Furthermore, environmental design implementation was shown to have a significant effect on business competitive advantages. The 'more successful environmental design implementation results in greater competitive advantages'

hypothesis is statistically tested and proven in this research. The two intermediate variables, industry group and enterprise scale, do not show noticeable impacts on environmental design and business competitive advantages.

Tan (2005) conducted a survey in Malaysia using a sampling frame consisting of all 38 companies that were certified with ISO 14001 since 1998. It was thought that only those with several years of registration would be able to supply information on at least perceived benefits. In fact, for smaller companies, the payback period for ISO 14001 certification was found to be longer and might take up to ten years (Freidman and Walter, 2002). The sampling frame was based on the list published by SIRIM (SIRIM 1998), the registering authority in Malaysia. However, only 18 responses were received. Due to the small number of firms involved, results of hypothesis testing were not used in the analyses. Instead, the analyses had to be confined to simple descriptive statistics and cross-tabulations. The results of a survey on Malaysian firms registered with ISO 14001 indicated that there were benefits to be gained from implementing ISO 14000 standards. Generally, the benefits were rather similar to those documented for companies that adopted ISO 14000 in industrialized countries. ISO 14000 implementation was crucial in bringing about effective environmental management and reduction of damage to the environment, as well as improvement of the company's image and operations.

The introduction of environmental management systems is relatively recent in the New Zealand context, yet there are three main EMS being implemented throughout the New Zealand wine industry. These are: Sustainable Winegrowing New Zealand (SWNZ), ISO 14001 and Bio-Gro. Hughey *et al.* (2005) carried out a qualitative survey of vineyards, using interview-based questions rather than via a long-term quantitative examination of biophysical indicators that would enable an 'objective' inter-system evaluation. Fifteen selected vineyards/wineries (four Bio-Gro, five ISO 14001 and six SWNZ) were chosen for the study. The ISO 14001 accredited companies surveyed noted that, in addition to shared benefits, they also experienced: decreased waste, particularly through recycling; decreased use of natural resources; continual improvement of business systems; peer support and information sharing (Riddiford, 2001). Apart from the comment regarding eventual savings, the majority of ISO 14001-company spokespeople stated that they were yet to see any economic benefits. Additional benefits noted by an ISO 14001 company spokesperson were increased accountability, the empowerment of staff and the ability to drive constant improvement within the company.

Rennings *et al.* (2006) carried out a preliminary telephone survey (regarding the design of the questionnaire), including twelve case studies within German EMAS-validated facilities (in Baden-Wurttemberg) which covered the most important economic sectors. For these case studies, environmental reports were analyzed and semi-structured face-to-face interviews with facility representatives were conducted. On this basis, a broad telephone survey of EMAS validated facilities was conducted. In this way, it was possible to analyze the impacts of different characteristics of EMAS on technical environmental innovations and economic performance. It can be summarized that most German EMAS validated facilities report a positive influence of EMS on environmental process innovations. In addition, environmental reports support the diffusion of technical environmental innovations. The study showed as

well that environmental process innovations particularly depended on the maturity of EMS (measured as two re-validations of EMAS and prior experience concerning the organization of environmental protection). Another important determinant of environmental process innovations is the strong participation of specific departments (RandD) in the further development of EMAS. Learning processes by EMS have a positive effect both on learning product innovations and increase of turnover and exports. Moreover, environmental process innovations had a positive influence on the increase of the number of employees and turnover.

References

- Ammenberg, J. and Hjelm, O. (2002). The connection between environmental management systems and continual environmental performance improvements. *Corp Environ Strat* **9**(2), 183–192.
- Arora, D.K.C. (2000). TQM and ISO 14000. Millenium edition (S.K. Kataria, ed.), pp. 698, 720–721. Delhi, India.
- Babakri, K.A., Bennett, R.A. and Franchetti, M. (2003). Critical factors for implementing ISO 14001 standard in United States industrial companies. *J Cleaner Prod* **11**, 749–752.
- Barg, S. (1996). *Global Green Standards: ISO 14000 and Sustainable Development*. International Institute for Sustainable Development, Canada.
- Begley, R. (1997). 14000 A step toward industry self-regulation. *Environ Sci Technol* **30**(7), 298–302.
- Begley, R. (1997). Value of ISO 14000 management systems put to the test. *Environ Sci Technol* **31**(8), 364–366.
- Biggs, R.B. and Nestel, G.K. (1995). *Proactive building blocks for achieving global sustainable development*. Roy F. Weston, Inc. <http://www.rfweston.com/sd/iso>.
- Boudouropoulos, I. and Arvanitoyannis, I.S. (1999). Current state and advances in the implementation of ISO 14000 by the food industry. Comparison of ISO 14000 to ISO 9000 to other environmental programs. *Trends Food Sci Technol* **9**, 395–408.
- Boudouropoulos, I. and Arvanitoyannis, I.S. (2000). Potential and perspectives for application of Environmental Management System (EMS) and ISO 14000 to food industries. *Food Rev Int* **16**(2), 177–237.
- Business and the Environment's ISO 14000 Update. (1996). In *Business and the Environment's ISO 14000 Update* Cutter Information Corp. <http://www.cutter.com/iso14000/>, December.
- Canter, R. (1995). How to compete. *Harvard Business Review*, July–August.
- Carawan, E. (1995). Cleaner technologies for cereal manufacturing. *Cereal Foods World* **40**(11), 799–800.
- Cascio, J., Woodside, G. and Mitchel, P. (1996). *ISO 14000 Guide: the new environmental standards*. McGraw-Hill, New York.
- Chen, C.-C. (2005). Incorporating green purchasing into the frame of ISO 14000. *J Cleaner Prod* **13**, 927–933.

- Chen, Z., Li, H. and Hong, J. (2004). An integrative methodology for environmental management in construction. *Automation Construct* **13**, 621–628.
- Darbra, R.M. (2005). Una nova metodologia per a la valuacio de la gestio ambiental en ports de mar. PhD Thesis, Universitat Politecnica de Catalunya, Barcelona.
- Data collected from isofakta* (1999). www.isofakta.com/.
- Demetrakes, P. (1996). Wringing success. *Food Proc* **57**(12), 73.
- Diamond, C.P. (1996). *Environmental management system demonstration project – final report*. NSF International, Michigan.
- Ember, L. (1995). Responsible care: chemical makers still counting on it to improve image. *CandEN* **5**, 10–18.
- Emilsson, S. and Hjelm, O. (2002). Implementation of standardised environmental management systems in Swedish local authorities: reasons, expectations and some outcomes. *Environ Sci Pol* **5**, 443–448.
- Envirocom Systems. *ISO 14000* <http://www.envir.com/iso/>.
- Environmental Management Systems (ISO 14000 series)* International Forum for Management Systems, <http://www.informintl.com/managesyslinks.html>.
- Fredericks, I. and McCallum, D. (1995). *International standards for environmental management systems: ISO 14000* MGMT Alliances Inc. Originally published in Canadian Environmental Association, <http://www.mgmt14k.com/>.
- Freidman, J. and Walther, M. (2002). The impact of corporate environmental management systems – A comparison of EMAS and ISO 14001. *Green Manage Int* **36** winter, 91–103.
- Galan, M.B., Perschard, D. and Boizard, H. (2007). ISO 14001 at the farm level: analysis of five methods for evaluating the environmental impact of agricultural practices. *J Environ Management* **82**(3), 341–352.
- General Principles and Practice Guidelines for Environmental Auditing* Canadian Environmental Auditing Association, (1998) May.
- Ghisellinia, A., Deborah, L. and Thurston, D.L. (2005). Decision traps in ISO 14001 implementation process: case study results from Illinois certified companies. *J Cleaner Prod* **13**, 763–777.
- Giese, J. (1996). ISO 14000 is coming. *Food Techn* **50**(7), 34.
- Goodchild, E. (1998). *The business benefits of EMS approaches*. Salford University, Salford.
- Goodman, S.L. (1998). Is ISO 14001 an important element in business survival? *Qual Mag Australia* **6**.
- Haklik, J.E. (1998). Benefiting from pollution prevention. *Transformation strategies*, <http://www.trst.com>.
- Haklik, J.E. (1998). ISO 14001 and sustainable development. *Transformation strategies*, <http://www.trst.com>.
- Helby, P. (2002). EKO-Energi – a public voluntary programme targeted at Swedish firms with ambitious environmental goals. *J Cleaner Prod* **10**, 142–151.
- Hillary, R. (1995). Small firms and the environment – a groundwork status report. Groundwork, Birmingham.
- Hillary, R. (1997a.) The eco-management and audit scheme: analysis of the regulation, implementation and support. Imperial College, London.

- Hillary, R. (1997b). UK national co-ordinator's report on euromanagement – environment pilot action. Imperial College, London.
- Hillary, R. (1998). An assessment of the implementation status of council regulation (No 1836/93) eco-management and audit scheme (EMAS) in the European Union Member States (AIMS – EMAS). Imperial College, London, <http://europa.eu.int/comm/emas>.
- Hillary, R. (2004). Environmental management systems and the smaller enterprise. *J Cleaner Prod* **12**, 561–569.
- Hughey, K.F.D, Tait, S.V. and O'Connell, M.J. (2005). Qualitative evaluation of three 'environmental management systems' in the New Zealand wine industry. *J Cleaner Prod* **13**, 1175–1187.
- Hunt, D. and Johnson, C. (1995). *Environmental management systems principles and practices*. McGraw-Hill, London.
- ISO 14000 – Is it time for your company to become certified? ISO 14001 Overview by Capaccio Environmental Engineering Inc., <http://www.iso14000.com/>.
- ISO 14000 Registration Process TUV North America Inc., <http://www.us.tuv.com/>.
- ISO 14001:2004 IOSH briefing on the revised Standard, <http://www.iosh.co.uk/files/publications/ISO14001update.pdf>.
- Jackson, J. (1997). ISO 14000: What you need to know. *Hydrocarbon Process* **76**(4), 133–137.
- Jackson, S.L. (1997). *The ISO 14001 Implementation Guide*. John Wiley & Sons Inc., New York.
- Japan Accreditation Board for Conformity Assessment (1999), <http://www.jab.or.jp/eng/htm/>.
- Johansson, L. (1997). The challenge of implementing ISO 14001 for small- and medium-sized enterprises – surviving in the new global jungle. *Environ Qual Manage* **7**(2), 9–19.
- Kuhre, W.L. (1995). *ISO 14010s Environmental auditing*. Prentice-Hall, New Jersey.
- Kuhre, W.L. (1995). *ISO 14001 Certification environmental management systems*. Prentice Hall PTR, New Jersey.
- Lamprecht, J.L. (1996). ISO 14000. In *ISO 14000*. Amacom, New York.
- Lash, J. and Buzzelli, D. (1995). The president's council on sustainable development. *Environment* **37**(3), 44–45.
- Lozano, M. and Valles, J. (2006). An analysis of the implementation of an environmental management system in a local public administration. *J Environ Manage* **82**(4), 495–511.
- Mohamed, S.T. (2001). The impact of ISO 14000 on developing world businesses. *Renewable Energy* **23**, 579–584.
- Mori, J. (1994). Eco-management and audit scheme. Research study conducted by Mori for the Department of the Environment, London, UK.
- Murray, P.C. (1997). The international environmental management standard, ISO 14000: a non tariff barrier or a step to an emerging global environmental policy?. *U PA J Int Econ Law* **18**(2), 577–615.
- NSAI's ISO 14001:2004 transition policy, http://www.nσαι.ie/News_and_Events/upload/transition_plan.pdf.
- Petroni, A. (2001). Developing a methodology for analysis of benefits and shortcomings of ISO 14001 registration: lessons from experience of a large machinery manufacturer. *J Cleaner Prod* **9**, 351–364.

- Post, J.E. and Altman, B.W. (1994). Managing the environmental change process: barriers and opportunities. *J Organ Change Manage* 7(4), 64–81.
- Propper, S. (1998). *Environment Report 1998*. Unilever Corporate Relations Department: London and Rotterdam, April.
- Quality Network. (1996). *International Standard ISO 14000*, <http://www.quality.co.uk/quality>.
- Rennings, K., Ziegler, A., Ankele, K. and Hoffmann, E. (2006). The influence of different characteristics of the EU environmental management and auditing scheme on technical environmental innovations and economic performance. *Ecol Econom* 57, 45–59.
- Revision to ISO 14001 what the publication of the 2004 edition means for organizations using the standard, http://www.iema.net/library/ISO14001_changes/ISO%2014001%20changes.pdf.
- Riddiford, R. (2001). ISO 14001 and the living wine group. In *Proceedings of the Eleventh Australian Wine Industry Technical Conference*, Adelaide, 7–11 October 2001 (R. Blair, P. Williams and P. Ho, eds). Australian Wine Industry Technical Conference Inc., Glen Osmond.
- Romanow-Garcia, S. (1996). Is the HPI ready for ISO 14000?. *Hydrocarbon Process* 75(6), 15.
- Rothery, B. (1993). *BS-7750 Implementing the environmental standard and the EC eco-management scheme*. VT Gower Press, Brookfield.
- Savely, S.M., Carson, A.I. and Delclos, G.L. (2006). A survey of the implementation status of environmental management systems in US colleges and universities. *J Cleaner Prod* 15(7), 650–657.
- Seif, J.M. (1997). *ISO 14000: privatizing environmental regulation – an idea without borders*. Pennsylvania Department of Environmental Protection, <http://www.dep.state.pa.us>.
- Shah, G. (1997). Use ISO 14000 as a compliance and productivity tool. *Hydrocarbon Process* 76(8), 75–77.
- Shirley, K. (1997). ISO breakthrough on forestry. *Forestry Chron* 72(5), 456.
- SIRIM (Standards and Industrial Research Institute of Malaysia). QAS Directory of Certified Products & Companies 1998.
- Stauffer, J.E. (1997). ISO 14000 standards. *Cereal Foods World* 42(4), 228–230.
- Summers Raines, S. (2002). Implementing ISO 14001 – an international survey assessing the benefits of certification corporate environmental strategy. *Corp Environ Strategy* 9(4), 418–426.
- Tan, L.P. (2005). Implementing ISO 14001: is it beneficial for firms in newly industrialized Malaysia? *J Cleaner Prod* 13, 397–404.
- Tansey, G. and Worsley, T. (1995). *The food system: a guide*. Earthscan Publ. Ltd, London.
- Thayer, A. (1996). Chemical companies take-wait-and-see-stance toward ISO 14000 standards. *CandEN* 74(4), 11–15.
- The ISO 14000 Pizza* MGMT Alliances Inc., <http://www.mgmt14k.com/>.
- The ISO 14000 series of EMS Standards* Standards Council of Canada (SCC), <http://www.scc.ca/iso14000/>.
- The Number of ISO 14001/EMAS certification registration of the world* ISO World, <http://www.ecology.or.jp/>.

- Tibor, T. and Feldman, J. (1997). Implementing ISO 14000. In *Implementing ISO 14000*. Irwin Profess Library Publication.
- Tien, S.-W., Chung, Y.-C. and Tsai, C.-H. (2005). An empirical study on the correlation between environmental design implementation and business competitive advantages in Taiwan's industries. *Technovation* **25**, 783–794.
- Tropea, L.C. (1997). An opinion. ISO 14000: a corporate perspective. In *An opinion. ISO 14000: A corporate perspective*. Pennsylvania Department of Environmental Protection, <http://www.dep.state.pa.us>.
- What is ISO 14000? Questions and Answers*. Standards Council of Canada: Ottawa, <http://www.scc.ca/iso14000/infobref.html>.
- Zeng, S.X., Shi, J.J. and Lou, G.X. (2006). A synergetic model for implementing an integrated management system: an empirical study in China. *J Cleaner Prod* (in press).
- Zeng, S.X., Tamb, C.M., Tamb, V.W.Y. and Deng, Z.M. (2005). Towards implementation of ISO 14001 environmental management systems in selected industries in China. *J Cleaner Prod* **13**, 645–656.
- Zutshi, A. and Sohal, A. (2004). A study of the environmental management system (EMS) adoption process within Australasian organisations – 2. Role of stakeholders. *Technovation* **24**, 371–386.

ISO 14040: Life Cycle Assessment (LCA) – Principles and Guidelines

Ioannis S. Arvanitoyannis

The concept of LCA	97
The structure of LCA	98
Examples of LCA studies on food production systems	99
LCA case studies reported	106
LCA in the future	126

The concept of LCA

Every day in the marketplace, people make choices that affect, directly or indirectly, the environment. Manufacturers choose from among different materials, suppliers or production methods. Consumers, for their part, either choose among products or whether to use a product at all. Those who would like to make environmentally responsible choices need reliable information which is frequently related to life cycle assessment (LCA) (<http://www.tc207.org/articles/>).

LCA considers the environmental aspects and the potential impacts of a product or a service system throughout its life – from raw material acquisition through production, use and disposal (from cradle to grave). This information is very important and can be of great help in identifying ways to improve environmental aspects of a product at various stages in its life cycle, to support decision-making in industry, governmental or non-governmental organizations. It can substantially help the selection of various indicators of environmental performance (EP) and (with proper precautions) to promote the marketing of products or services (EPA, 1994). The Society for Environmental Toxicology and Chemistry (SETAC) defines LCA as the:

Process to evaluate the environmental burdens associated with a product, process or activity by identifying and quantifying energy and materials used and wastes released to the environment; to assess the impact of those energy and material uses and releases to the environment; and to identify and

evaluate opportunities to effect environmental improvements. The assessment includes the entire life cycle of the product, process or activity, encompassing extracting and processing raw materials; manufacturing; transportation and distribution; use, re-use, maintenance; recycling; and final disposal (EPA, 1994).

The main focus of LCA is to determine the environmental impacts of the system under study in the areas of ecological well-being, human health and resource depletion (Tansey and Worsley, 1995). ISO 14041 is entitled 'Life Cycle Assessment – Goals and Definition/Scope and Inventory Analysis' and is intended to describe the special requirements and guidelines for the preparation, conduct and critical review of the life cycle inventory analysis.

The structure of LCA

The most widely accepted LCA structure is the one suggested by SETAC as described in Table 3.1. The term 'life cycle analysis' is often employed for the analysis stage of a life cycle assessment.

Goal definition (ISO 14040) is perhaps the most important component of LCA. The inventory (ISO 14041) is an analysis, qualitative and/or quantitative, of the resources used and the emissions generated in the life cycle. The impact assessment (ISO 14042) can be divided into classification, characterization and valuation (Andersson *et al.*, 1994). The assessed impacts fall into three broad categories: human health, ecological health and resource use (Tansey and Worsley, 1995). Characterization is the aggregation of inventory data within the impact categories by the use of equivalency factors (Andersson *et al.*, 1994). It is a largely quantitative step that analyzes the relative contribution of the multiple inputs or outputs by category (Tansey and Worsley, 1995). Valuation can be carried out either qualitatively or quantitatively by expert panels or by comparison of environmental loading profiles, respectively (Andersson *et al.*, 1994; Boudouropoulos and Arvantioyannis, 1999). Interpretation (ISO 14043) stands for conclusions based on the assessment and suggestion of improvement actions.

Table 3.1 Structure of LCA suggested by the Society of Environmental Toxicology and Chemistry (SETAC)

Analysis	Goal definition and scoping Inventory analysis
Assessment	Impact assessment, which is divided into: Classification Characterization Valuation Improvement analysis

Andersson *et al.*, 1994, Tibor and Feldman, 1997

International Standards are playing a critically important role in all industries for national production, international terminologies, safety and health protection, measurements, analysis, quality control and environmental protection, particularly in the energy field, where standards for the interfaces in energy flows are indispensable, such as electric connectors, fueling devices, calibration methods and electrical safety. Besides the specific standards for petroleum, coal, nuclear and hydro-power, hydrogen and the vast field of electricity, the energy standards series ISO 13600 allows the characterization, analysis and comparison of all energy systems and soon will issue a global energy statistics and planning matrix for the transition to environmentally-sound sustainable economics. These standards allow integrated resource planning, including all new renewable options, such as the increasingly important direct and indirect solar energy, co-generation, hybrid systems, small decentralized units, bio-energy, ambient temperature use by heat pumps and substitutions of muscle-powered systems or vice versa, besides the more efficient production and use of conventional finite and renewable energy-sources (Grob, 2003). The total cost of their emissions, their net gray, i.e. re-usable embedded energy, can be determined, total and relative efficiencies can be calculated and their life cycles and risks can be assessed with this new standard tool in conjunction with the many existing and emerging standards on specific energy systems or parts thereof (Figure 3.1).

Examples of LCA studies on food production systems

Most of the initially conducted LCA studies compared different packaging materials. For example, for milk, a large number of studies has been carried out comparing single-use cartons with disposable and refillable bottles of both glass and polycarbonate. An ecologically sound recycling and recovery of the packaging material strategy combines mechanical recycling with efficient feedstock recycling and energy techniques. The analysis clearly showed that mechanical recycling of the high-grade film and bottle fractions, which only accounted for about 30% of the plastic packaging of households, has already reached its limits (Boudouropoulos and Arvanitoyannis, 1999, 2000).

In the feedstock recycling and energy recovery sectors, the blast furnace process, thermolysis using the BASF process, monocombustion, for which pilot plants are only available abroad at present, and hydrogenation at the Kohle-OI-Anlage are in the top group. Consequently, classification into mechanical recycling, feedstock recycling and energy recovery techniques is merely process-orientated and does not constitute an ecological evaluation (Rob, 1996). Table 3.2 provides a synoptic presentation of the LCA studies carried out on foods and (food) packaging materials.

Life cycle assessment (LCA), the systematic inventory and evaluation of environmental impacts of a product ‘from the cradle to the grave’, is an emerging tool. On one hand, it is used by governments, e.g. when establishing ecolabeling criteria for certain product groups or when defining mandatory re-use or recycling quotas as done

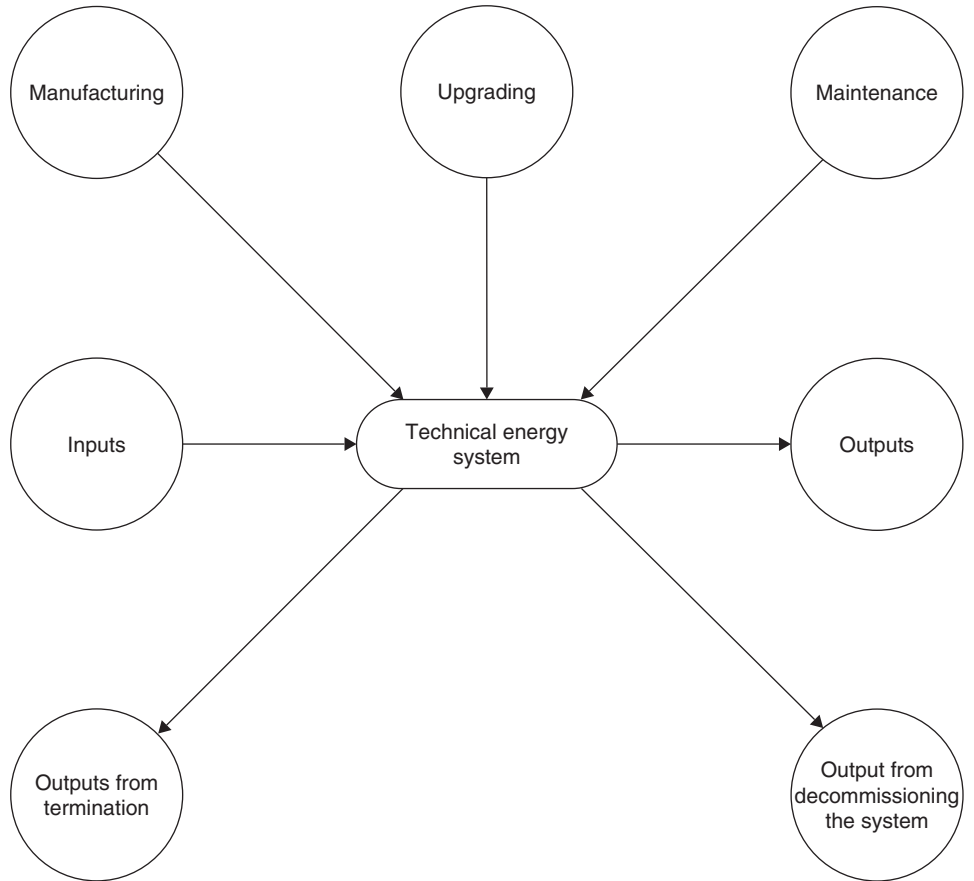

Figure 3.1 Factors affecting the total cost of emissions (adapted from Grob, 2003)

in the context of the German packaging ordinance. On the other hand, it is increasingly applied by companies for the identification of environmental weak spots in products and for product development (Grotz and Scholl, 1996; Oosterhuis *et al.*, 1996; Rubik, 1997; Scholl and Nisius, 1998).

LCA methodology has become well known and accepted in both Europe and the USA and is a procedure used to quantify inputs and outputs related to a product or an activity system. It may be used to assess environmental performances of industrial and consumer goods from the very beginning of their production to the end of their use, both for internal (e.g. improvement of product performances) and external uses (e.g. communication or marketing) (Vigon and Jensen, 1995). LCA is a process:

to evaluate environmental burdens related to products, processes or activities, to identify potential impacts on the environment coming from energy or material consumptions, to identify and to evaluate possible product improvements (SETAC, 1993).

Table 3.2 LCA studies on foods

Product (food)	Country	Effect	Reference
Peas, bread and milk products	The Netherlands	Environmental impacts from packaging in proportion to other parts of the food supply system	Kooijman, 1993
Margarine	The Netherlands	Two margarines and two low-fat products were investigated, concentrating on the fat components and packaging	Vis <i>et al.</i> , 1992
Bread and meat	Denmark	Qualitative study with a very broad definition of environmental parameters	Pedersen, 1992
Canned cooked products	Austria	Application of the Institute for Ökologische Wirtschaftsforschung's eco-balance system. The study involved four canning industries and one producer of packaging	IOW Wien, 1992
Fruit yogurt	Germany	Comparison of processed products from ordinary and ecological agriculture	Ott, 1992
Bread, beer and cheese	Germany	Comparison of processed products from ordinary and ecological agriculture	Ott, 1992
Tomatoes and cucumbers	Switzerland	Comparison of seven hydroponic systems and eight ordinary production systems (under glass, in tunnels, and outdoor production)	Hahn, 1992
Tomatoes	Switzerland	Comparison of seven different ways of producing tomatoes under glass	Gysi and Reist, 1990
Potatoes	Switzerland	Investigation of seven combinations of thermal, mechanical and chemical potato topping	Jolliet, 1993
Milk chain supply	Sweden	The total use of energy and packaging materials seems to be critical to the outcome. More knowledge of the amount of wastage in households is required, both in absolute numbers and as influenced by the type of packaging	Sonesson and Berlin, 2003
Ketchup production	Sweden	Six alternative sub-systems, including packaging, processing and transportation, were modeled and simulated. The environmental impact categories included were energy use, global warming, acidification, eutrophication, photo-oxidant formation and the generation of radioactive waste. It was concluded that the contributions to acidification can be reduced significantly and the environmental profile of the product can be improved for either the type of tomato paste currently used or a less concentrated tomato paste	Andersson and Ohlsson, 1999
Milk production	Spain	Different sub-systems were identified and thoroughly studied – farms, fodder factories and dairies – and even though the collection of their inventory data took place throughout one complete year, some values were found to vary considerably. Raw milk production, specifically the agricultural phase, and packaging manufacture have been identified as the crucial elements. Other aspects such as formulation of animal food at farms and emission from boilers at dairies are also decisive when improvement actions are to be set up	Hospido <i>et al.</i> , 2003
Beer	Greece	The impact categories most affected by the beer production are the earth toxicity or heavy metals and the	Koroneos <i>et al.</i> , 2005

(Continued)

Table 3.2 (Continued)

Product (food)	Country	Effect	Reference
Wild caught and farmed salmon	Norway	category of smog formation. Bottle production, followed by packaging and beer production are found to be the sub-systems that account for most of the emissions The fishing phase for the cod and the feeding phase for both salmon and chicken dominate for all environmental impacts considered. Chicken is most energy effective followed by salmon and cod, which are almost on the same level. The area of sea floor affected by bottom trawling is around 100 times larger than the land area needed to produce the chicken feed for production of the 0.2 kg fillet. There is potential for improvement of environmental performance, both for salmon farming and cod fishing, especially when it comes to energy use	Ellingsen and Aanonsen, 2006
Danish fish products	Denmark	Energy consumption is a key factor contributing to the environmental burden for all investigated fish products. The (quantitative) LCA suggests that the environmental hotspot for flatfish is the fishing stage. The same applies to cod, Norway lobster, shrimp and prawn. Generally, however, the use and retail stages are also important, while the processing stage only represents an important impact potential for certain types of fish products (pickled herring, canned mackerel and mussels)	Thrane, 2006
Fish	The Netherlands	Impacts such as climate change, stratospheric ozone depletion, photo-oxidant formation (smog), eutrophication, acidification, toxicological stress on human health and ecosystems, the depletion of resources and noise. The need exists to address these product-related contributions more holistically and in an integrated manner, providing complementary insights to those of regulatory/process-oriented methodologies	Pennington <i>et al.</i> , 2004
Canned tuna	Spain	The system under study included landing at harbor, transport to the factory, processing inside the factory, final product distribution to markets and use in households. The results show that processing accounted for the greatest percentage in all the impact categories, except human toxicity potential. Inside the factory, the production and transportation of tinplate was identified as the most significant contributor and, consequently, improvement actions were proposed and evaluated, such as an increase in the percentage of the recycled tinplate	Hospido <i>et al.</i> , 2006
Soft drink containers	Israel	A fair and globally sustainable comparison is feasible only if the costs of environmental burdens (or benefits) are to be internalized in the price of the product	Ayalon <i>et al.</i> , 2000
Egg packaging (polystyrene and recycled paper)	Greece	PS packages contribute more to acidification potential, winter and summer smog, while recycled paper egg packages contribute more to heavy metal and carcinogenic substances impact. Paper eggcups have less environmental impact than the polystyrene ones	Zabaniotou and Kassidi, 2003

(Continued)

Table 3.2 (Continued)

Product (food)	Country	Effect	Reference
Alternative coffee packaging	Italy	Issues pointed out during the analysis recommend particular diligence regarding the selection of materials used for packaging production, an element required during the design phase. The results of the study also show that the use of poly laminated bags instead of metallic cans in the case of small size packages could be an alternative, even though this solution does not favor material recycling	De Monte <i>et al.</i> , 2005
Environmental sustainability in food production systems	The Netherlands	The systemic approach can calculate trade-offs along supply chains that make up a production system. The use of the method implies an extension of environmental SCP towards the overall performance of a production system. The final outcome is expressed in three performance indicators: the total land, energy and water requirement per kilogram of available food. For companies, the data generated can be used to compare trends over time, to compare results with targets and to benchmark a company against others. For consumers, data can be used to compare the environmental effects of various foods	Gerbens-Leenes <i>et al.</i> , 2003
Comparison of two packaging materials; expanded polystyrene (EPS) and corrugated paperboard (CPB)	Singapore	LCA was used to investigate, quantify and compare the potential environmental impacts of the life cycles of two packaging materials, EPS and CPB inserts. The first LCA cradle-to-gate study and impact assessment results highlighted quantitatively the environmental benefits of redesigning the products to consume less material. The next LCA study explored various waste scenarios for EPS and CPB inserts, displaying the positive and negative environmental impacts of landfilling and incineration options, as well as transportation. The least overall damage caused to the environment for the 'cradle-to-grave' study of both EPS and CPB comes from increased incineration practices (90-100%) and the worst from landfilling	Tan and Khoo, 2005
Reusing food packaging (plastic)	Australia	The life cycle impacts in all impact categories examined in this study were less for the proposed EPSHIPS/PE shrink-wrap packaging than for the present EPS/PE packaging. This is due to its lighter weight and also to the innovative recycling/re-use strategy for the new packaging system	Ross and Evans, 2003
Pesticides on humans and ecosystems	Italy	The life cycle assessment of impact of pesticides on human health and ecosystems was determined by means of a full-fate analysis and exposure to toxic pollutants through different media and pathways, including residues in food, based on the behavior of the pesticides in air and the importance of transfers between soil and surface or groundwaters. For human toxicity, estimates of pesticide residues showed that food intake results in the highest toxic exposure, about 10^3 to 10^5 times higher than that induced by drinking water or inhalation. An intra-species extrapolation factor of 10 explained the relationship between acute (LC50) and chronic (NOEC) ecotoxicity, whereas it was not suitable for inter-species extrapolation	Margni <i>et al.</i> , 2002

(Continued)

Table 3.2 (Continued)

Product (food)	Country	Effect	Reference
Pest management toxicological impact in greenhouses	Spain	Both the USES-LCA model and the empirical model CST showed in general a higher level of potential contamination in greenhouses treated with CPM, permitting a quantification of these values. Results must be considered as relative values due to the level of uncertainty of both methods	Anton <i>et al.</i> , 2004
Human intake of toxic pollutants	The Netherlands	The human population intake fraction is on average 10^{-5} – 10^{-8} for organics and 10^{-3} – 10^{-4} for inorganics, depending on the emission compartment considered. Chemical-specific human population intake fractions can be 1–2.7 orders of magnitude higher or lower compared to the typical estimates. For inorganics, the human population intake fractions highly depend on the assumption that exposure via food products can be modeled with constant bioconcentration factors. The environmental fate factor is on average 10^{-11} – 10^{-18} days m^{-3} for organics and 10^{-10} – 10^{-12} days m^{-3} for inorganics, depending on the receiving environment and the emission compartment considered. Chemical-specific environmental fate factors can be 1–8 orders of magnitude higher or lower compared to the typical estimates	Huijbregts <i>et al.</i> , 2005
Food waste management options	Australia	Compared with the other three options, centralized composting has a relatively poor environmental performance due to the energy-intense waste collection activities it requires. Implementing a separate collection and transportation system for organic waste results in relatively high environmental impacts due to the frequency of collections and the small quantities of green waste collected per household	Lundie and Peters, 2005
Solid waste management	Spain	Scenarios with energy recovery achieve better environmental performances than scenarios without energy recovery. The scenario with emphasis on the recovery of the putrescible fraction performs slightly better than the one which emphasizes the quality of the recovered materials, for most of the impact categories and impact assessment methods	Bovea and Powell, 2006
Wheat	The Netherlands	Comparison of wheat (only one herbicide treatment and only animal manure applied) to ordinary wheat (artificial fertilizer and employment of growth-regulating agents)	Jolliet <i>et al.</i> , 1996

The ‘from cradle to grave’ perspective, which LCA can take into account, makes it possible to judge and improve environmental performances over the entire life cycle, as well as appraise embodied improvements at particular levels. Nevertheless, depending on the specific requirements of a company, LCA may also be used in a limited perspective (‘from process to process’), which can be of particular interest should the company wish to analyze carefully a limited part of the whole life cycle, the one under its own control (De Monte *et al.*, 2005).

As regards the potential applications of LCA, Azapagic (1999) from Hospido *et al.* (2003) put forward the main uses as follows:

- 1 Identification of environmental improvement opportunities
- 2 Strategic planning or environmental strategy development
- 3 Product and process optimization, design and innovation
- 4 Environmental reporting and marketing.

Life cycle assessment (LCA) is an analytical tool for the systematic evaluation of the environmental aspects of a product or service system through all stages of its life cycle. A graphical description of LCA methodology based on the principles of ISO 14040 is shown in Figure 3.2.

The main applications of LCA are in:

- 1 Analyzing the origin of problems related to a particular product
- 2 Comparing improvement variants of a given product
- 3 Designing new products
- 4 Choosing among a number of comparable products (LCA part 1).

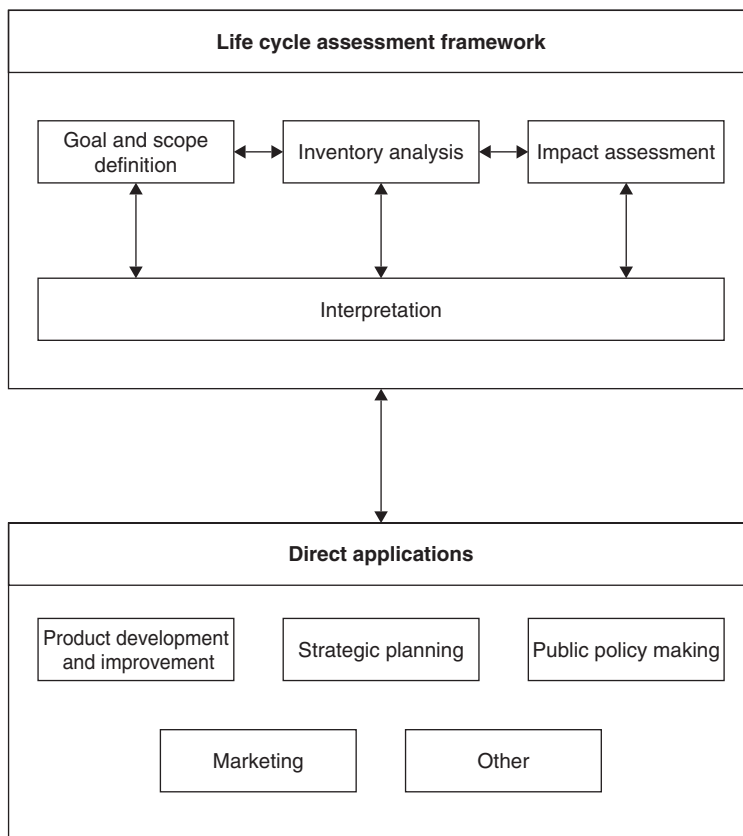

Figure 3.2 Phases and applications of an LCA (ISO 14040, 1997)

Pennington *et al.* (2004) recently compiled a review on the life cycle impact assessment (LCIA) phase, focusing on the key attributes of the supporting models and methodologies. These models and methodologies provide LCA practitioners with the factors they need for calculating and cross-comparing indicators of the potential impact contributions associated with the wastes, the emissions and the resources consumed that are attributable to the provision of the product in a study. ISO 14042, entitled 'Life Cycle Assessment – Impact Assessment (LCIA)', proposes to provide guidance on the impact assessment phase of LCA. This phase of LCA is aimed at evaluating the significance of potential environmental impacts using the results of the life cycle inventory analysis (Haklik, 1998). The environmental load unit taken from the natural resource or substance effect index multiplied by the amount of the substance used or released produces a total environmental load value (ELV) for the particular product or process (Kuhre, 1995). Because of the inherent subjectivity in impact assessments, the most critical requirement for their conduct will be disclosure, so that decisions and assumptions can be clearly described and reported (Haklik, 1998). LCIA consists of both mandatory and optional elements, as illustrated in Figure 3.3 (ISO 14042, 2000):

- 1 Selection of the impact categories of interest, the indicators per impact category and the underlying models (a procedure also considered in the initial goal and scope phase of an LCA)
- 2 Assignment of the inventory data to respective impact category. Impact categories include climate change, stratospheric ozone depletion, photo-oxidant formation (smog), eutrophication, acidification, water use and noise.

The food production industry requires large inputs of resources and causes several negative environmental effects. The food production systems are oriented and optimized to satisfy economic demands and the nutritional needs of a rapidly growing world population. Environmental issues, however, have not been given much attention. There are many difficulties in conducting life cycle studies of food products. Ideally, a complete study should include agricultural production, industrial refining, storage and distribution, packaging, consumption and waste management, all of which together comprise a large and complex system (Koroneos *et al.*, 2005).

LCA case studies reported

The typical problem encountered in the case of applying the LCA methodology to a food system is, besides the great gaps in accessible data, how to handle the agricultural production and the consumer phase; for both these phases, collection of representative data is only one difficulty. Agricultural production makes special demands on the LCA methodology (Heijungs, 1992; Tansey and Worsley, 1995; Rubik, 1997; Thrane, 2004). For instance, it is difficult to determine the system boundary between the technological system and nature; agricultural production takes place in nature itself and is actually a part of the environmental system. Ideally, all of the crops in a crop rotation system

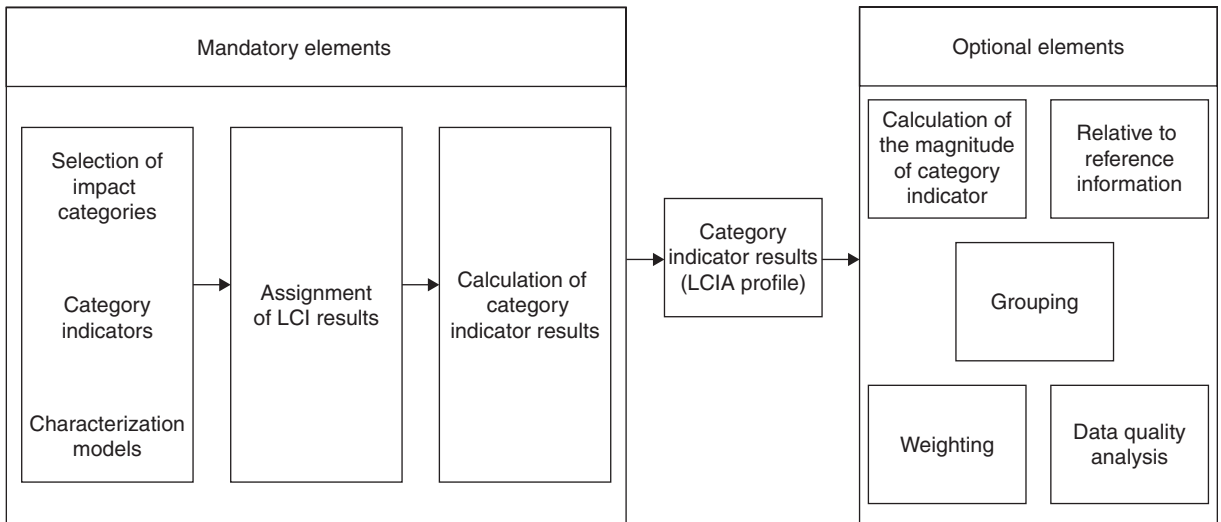

Figure 3.3 Elements of LCIA (ISO 14042, 2000)

should be studied, since a crop may be influenced by the previous crops; the environmental loads should then be allocated between the different crops (an allocation problem is how to handle common agricultural co-products such as straw and animal manure). Models to estimate the leakage of nutrients and pesticides in cultivation, for different soils, climate and crops, are needed in LCAs of food products; the models for characterization of human toxicity and ecotoxicity also need further development. In particular, the energy analysis indicates that the household phase and the behaviour of the consumer in conjunction with shopping (car use, distance and amount bought) may be very important. In addition, the 5% loss in the household phase is equivalent to 5% of the total environmental impact (Andersson and Ohlsson, 1999 ketchup).

The purpose of the ketchup LCA carried out by Andersson and Ohlsson (1999) was to identify 'hot-spots', that is parts of the life cycle that are important to the total environmental impact. The system investigated includes agricultural production, industrial refining, packaging, transportation, consumption and waste management. Energy use and emissions were quantified and some of the potential environmental effects assessed. Packaging and food processing were found to be hot-spots for many, but not all, of the impact categories investigated. For primary energy use, the storage time in a refrigerator (household phase) was found to be a critical parameter as well. For the production of tomato paste and ketchup, allocation was made by weight. The results obtained were validated in the following ways. At the tomato paste plant, mass allocation yields the following requirements per tonne of product: 5.9 GJ thermal and 0.38 GJ electrical energy. As to thermal energy use, the specific production line is dominated by the evaporation and sterilization steps for which data on the use of steam and electricity were collected and requirements of 5.1 GJ thermal and 0.18 GJ electrical energy per tonne tomato paste were calculated.

The beer production system investigated was divided into five subsystems. The life cycle can be described briefly as follows:

- 1 Raw material acquisition: the LCA study starts with the transportation of the raw materials to the fermentation factory. The transportation to the factory is made mainly by heavy-duty vehicles (containers and trucks), which use diesel fuel. The air emission factors (g pollutant/km) and the fuel consumption are calculated. The calculation is based on the type of vehicle and the average speed of the vehicle (Koroneos *et al.*, 2005). The pollutants that are calculated were CO, NO_x, high volatile organic chemical (VOC), PM, CO₂, and SO₂.
- 2 Beer production: the main ingredients for the production of beer are water and barley malt. To produce 1 liter of beer, the brewery will consume 5.25 liters of water close to the 7 liters reported in the literature (Andersson *et al.*, 1994). The production of beer is a batch process and 12 000 kg of barley malt are processed in each batch. Figure 3.4 shows the basic input and outputs in the beer production subsystem.
- 3 Bottle production: the bottle production was investigated and analyzed since the bottles are produced mainly from recycled glass.
- 4 Packaging and bottling: the bottling of one batch requires 140 376 bottles (0.546 kg of glass per bottle) including losses (about 3% of which is returned to the bottle producer as scrap glass). Of these bottles, about 51% is from returned bottles to the factory and the rest come from the bottle producer.
- 5 Transportation/storage/distribution: the LCA study was completed with the transportation and distribution of the produced beer to the consumers. Also the distribution of solid wastes and recyclable materials was taken into account.

According to the results obtained, it was concluded that for most of the impact categories, bottle production followed by packaging and beer production are the subsystems that contribute heavily to the adverse environmental impacts (emissions) of the beer production. Thus, the attempt to minimize the latter caused by beer production should focus on the minimization of the emissions released by these subsystems.

LCA was applied to egg packaging from polystyrene (PS) and recycled paper by Zabaniotou and Kassidi (2003). The input and output streams of mass and energy were examined and the environmental impacts associated with the two systems analyzed. The application of LCA by using EcoIndicator 95 has made possible the comparison of the environmental impacts of two egg packages. The results of this LCA study were discussed and revealed that the PS packages contribute more to acidification potential, winter and summer smog, while recycled paper egg packages contribute more to heavy metal and carcinogenic substances impact. Nevertheless, it seems that paper eggcups have less environmental impact than the polystyrene ones with the assumption that the accuracy of the results is confined by the credibility of European databases used for primary data.

The dairy sector has been extensively studied from the perspective of LCA in Norway: milk production (Hogaas, 2002); Sweden: milk production focused on the

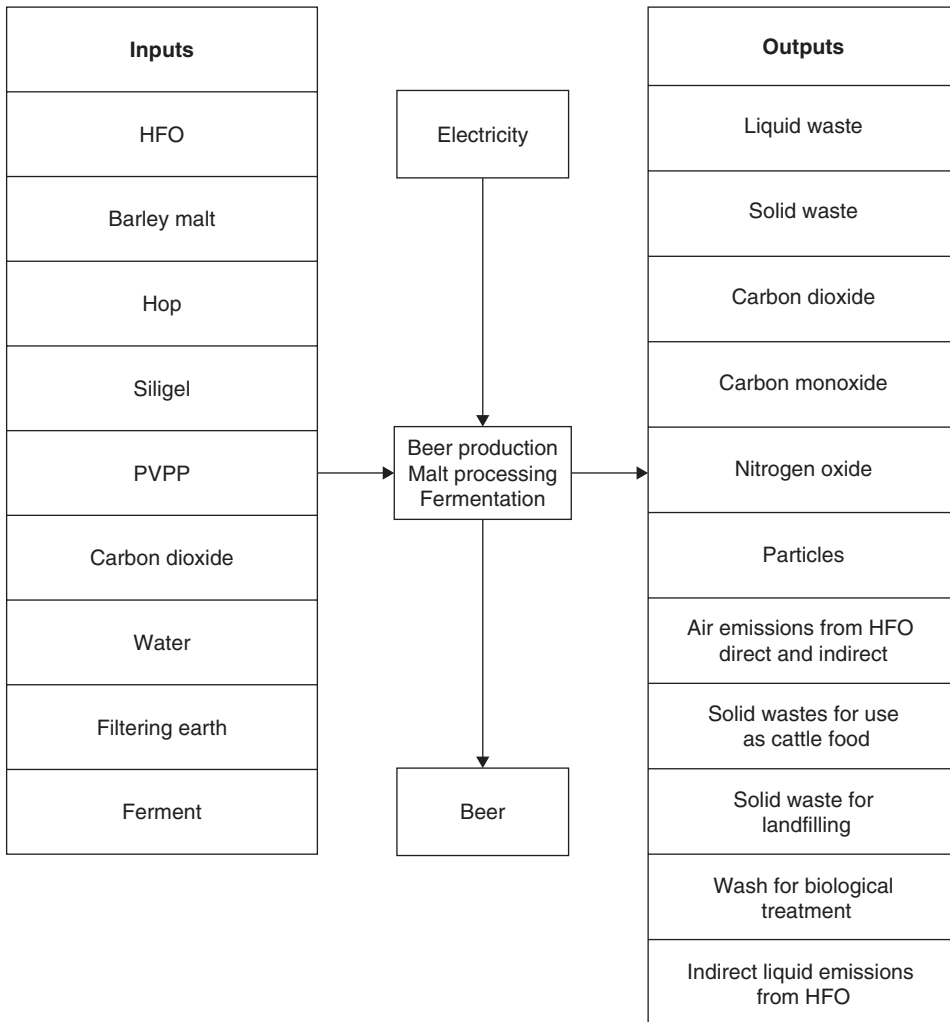

Figure 3.4 Input and outputs in the beer production subsystem for one batch (adapted from Koroneos *et al.*, 2005)

farm level (Cederberg and Mattson, 2000) and semi-hard cheese (Berlin, 2002); and Germany: milk production, with a special interest on impacts associated to agriculture (Cederberg and Mattson, 2000; Haas *et al.*, 2001). Although all dairy products are essential for the everyday nutritional regime, milk production has been chosen in this work as the most representative due to its outstanding position as an important staple food. In fact, most citizens consider consumption of milk in infancy, childhood and throughout adult life, as a prescription for good health. Regarding the different types of milk, skimmed milk (0.5% fat), semi-skimmed milk (1.5–1.8% fat) and whole milk (3.5% fat) are the most important ones (Hospido *et al.*, 2003). The life cycle of milk production included in the analysis by Hospido *et al.* is shown in Figure 3.5. In this

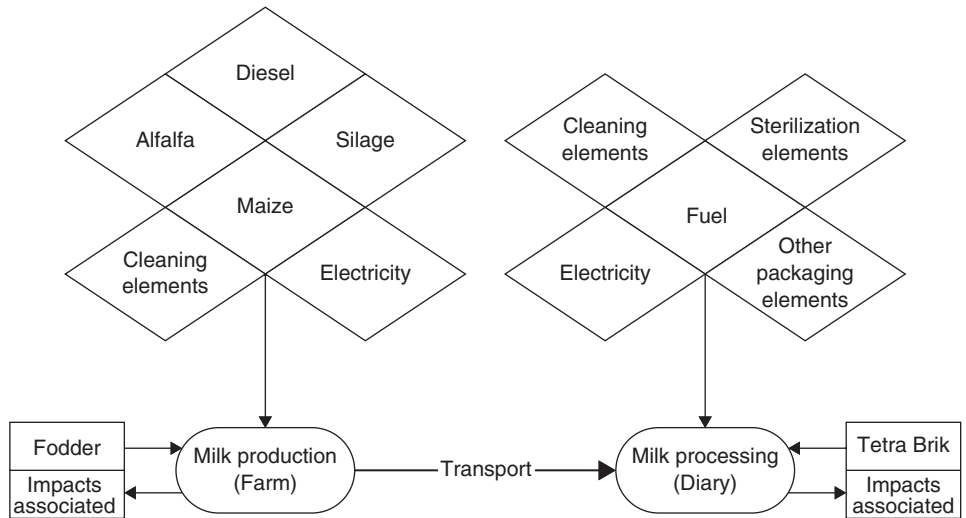

Figure 3.5 Schematic flow chart of the life cycle of milk. The main stages of the process are represented in blocks; inputs associated with industrial processes in triangles; inputs from LCA databases in continuous circles; impacts associated in discontinuous circles (adapted from Hospido *et al.*, 2003)

analysis, six categories have been considered (global warming, stratospheric ozone depletion, acidification, eutrophication, photo-oxidant formation and depletion of abiotic resources) as well as a flow indicator, energy consumption; on the contrary, others such as eco- and human toxicity and land use were not analyzed. In a qualitative way, they considered that potential damage over those categories should not be very significant if the nature of emissions (with the exception of pesticides at the agricultural phase) and the Galician land characteristics (low population density and low industrial character) are borne in mind. Among these six categories, three have been reported as significant: eutrophication, acidification and global warming. Several actions focused on these categories (specifically on eutrophication potential (EP) and acidification potential (AP)) have been proposed and the percentages of reduction have been measured. However, it is necessary to indicate that there is an action that, although it cannot be quantified, had to be pointed out due to its importance on global warming potential (GWP). Methane emitted by cows on farms is responsible for more than 30% of greenhouse gas emissions, so it has an outstanding weight. The elements involved at animal feed turned out to be accountable for an important percentage of all the impact categories at the farm level. In addition, the item 'impacts associated with milk production', which includes emissions to air as well as to water, were identified as responsible for certain categories (GWP and PCOP).

The milk supply chain model consists of two main parts: a background and a foreground system (Figure 3.6). The actual handling of dairy products is the foreground system. However, to supply the foreground system with such necessary inflows as packaging material, water and energy in various forms, and also to take care of its residues, background systems are necessary. The results from a simulation thus

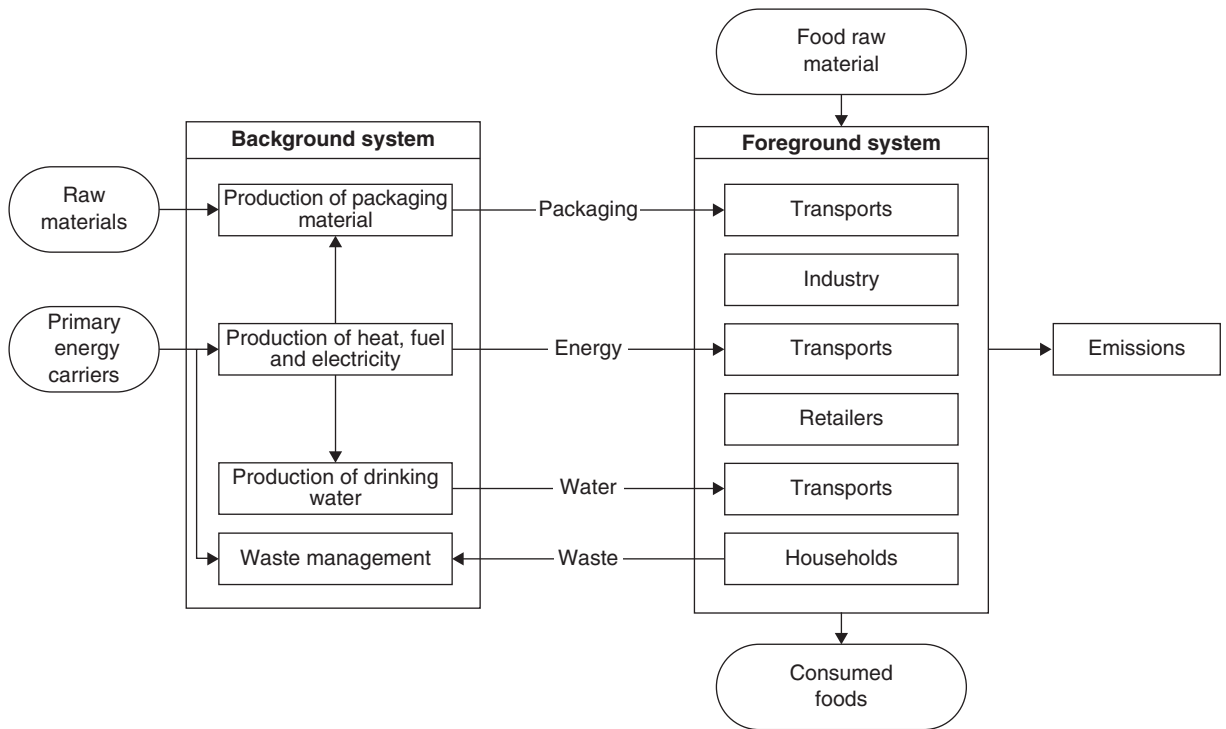

Figure 3.6 LCA in future milk supply chains in Sweden (adapted from Sonesson and Berlin, 2003)

include emissions from both background and foreground systems as well as all use of primary energy carriers caused by the milk supply chain. All models are static, i.e. the emissions and use of energy change linearly with changes in the flow, no economies of scale are assumed. The subsystems involved are as follows:

- 1 Truck transport
- 2 Car and van transport
- 3 Dairies
- 4 Retail
- 5 Households
- 6 Energy system
- 7 Production of packaging material
- 8 Production of drinking water
- 9 Waste management (Sonesson and Berlin, 2003).

Within dairies, more products and more frequent deliveries to retailers probably result in less efficient dairies. The effects are also noticeable in distribution, retailing, home transport and wastage within households. The model used in this study could still be improved to reflect fully the strong trends in this direction and provide reliable indications of their effects on environmental impacts. The total use of energy and packaging materials

seems to be crucial to the outcome. More knowledge of the amount of wastage in households is needed, both in absolute numbers and as influenced by the type of packaging. In future studies, it might be interesting to include agriculture in the analysis since different future scenarios will probably also affect the structure of agriculture. In this study, agricultural patterns would probably differ in the large-scale scenario and in the green IT-wave scenario and thus would have different impacts on the environment.

Due to the global aspects of production, use and disposal of goods, there should be a market mechanism to internalize environmental costs. The use of the suggested approach will promote optimal economic and environmental decisions with regard to soft drink containers. The multidimensional LCA methodology elaborated illustrated how to account for the full costs of alternative packaging materials and their disposal options, while taking into consideration the entire life cycle. To ensure a fair and globally sustainable comparison, the costs of environmental burdens (or benefits) should be internalized in the price of the product. This mechanism will ensure that there will be no advantage for importing countries over the exporting ones that bear most of the environmental burdens occurring mainly in the first stages (i.e. raw material acquisition) (Ayalon *et al.*, 2000).

Georgakellos (2005) proposed a new method for evaluating the results of a life cycle inventory using critical volume aggregation and polygon-based interpretation. It is designed to help decision-making in less sophisticated comparisons of products. Its main advantages are simplicity and flexibility, while it leads to an easily comparable single value, without being information intensive. As to disadvantages, except for the usual weaknesses of this kind of procedure, one can mention that some ambiguity cannot be avoided, while it may not result in a definite conclusion in specific conditions. An application of this method concerning the comparison of three soft drink containers (a glass bottle, an aluminum container and a PET bottle) is represented to illustrate the proposed framework. The life cycle system consists of 11 subsystems that together cover the entire life cycle of the containers. These subsystems are:

- 1 raw material acquisition and materials manufacture (it includes all the activities required to gather or obtain a raw material or energy source from the earth and to process them into a form that can be used to fabricate a particular container)
- 2 materials transportation (to the point of containers fabrication)
- 3 containers fabrication (this is the process step that uses raw or manufactured materials to fabricate a container ready to be filled)
- 4 containers transportation (to the point of filling)
- 5 filling-final product production (it includes all processes that fill the containers and prepare them for shipment)
- 6 final product transportation (to retail outlets)
- 7 final product use (it comprises activities such as storage of the containers for later use, preparation for use, consumption, etc.)
- 8 solid waste collection and transportation for landfilling (it begins after the containers have served their intended purpose and enter the environment through the waste management system)

- 9 solid wastes landfilling (it includes all necessary activities for the land disposal of waste)
- 10 used containers collection and refilling (it includes all the activities required to off-site re-use, such as the return of the containers to be re-filled for their original purpose)
- 11 recycling (it encompasses all activities necessary to take the used containers out of the waste management system and deliver them to the container fabrication stage).

These 11 subsystems that all together form the LCI system are represented in Figure 3.7.

The life cycle of rice (produced by vessel, medium-boiler and untreated process) was evaluated to determine environmental load and production cost of rice in Bangladesh. All the production processes have a negative effect on the environment and the environmental load varies from process to process. The inventory results (energy consumption and CO₂ emission) gradually decreased from the vessel to the untreated process (vessel > medium boiler > untreated). The untreated process was found to be both the environmentally sustainable and cost-effective process compared to the others, if milled rice is consumed instead of head rice (whole kernels after milling). A change in production process and consumption pattern (parboiled to untreated rice) would help to conserve 8–29% primary energy (biomass) and abate 2.5–9.6 million tons CO₂ emission per year in Bangladesh. Among the local parboiling processes, vessel and medium-boiler and the untreated process were considered to evaluate the life cycle of rice. Figure 3.8 shows the life cycle of rice under different processing methods (Roy *et al.*, 2007). The cost and profit are the most important indicators in decision-making on an investment. The processing capacity of the untreated process was assumed to be the same as the vessel process. Rice yield is an estimate of the quantity of rice (after milling) which can be produced from a unit of paddy and expressed in a percentage, i.e.

$$\begin{aligned} \text{Milled rice yield} &= [(\text{weight of rice kernels after milling})/(\text{weight of paddy})] \times 100, \\ \text{and head rice yield} &= [(\text{weight of whole rice kernels after} \\ &\quad \text{milling})/(\text{weight of paddy})] \times 100 \end{aligned}$$

The maximum head and milled rice yield were reported to be 68% and 70%, respectively for parboiled rice and these were 60% and 68%, respectively for untreated rice (Roy, 2003).

Seafood products have hardly been studied from an LCA perspective. Ziegler *et al.* (2003) have studied the entire life cycle of frozen cod as an example of seafood, emphasizing the fishery-specific types of environmental impact. Thrane (2004) worked on the analysis of a wide range of Danish fish products, such as flatfish, also from a life cycle perspective. A finding common to both studies is that the fish harvesting stage of the production cycle typically accounts for 70–95% of the total impact regardless of the impact category considered. Hospido and Tyedmers (2005) studied thoroughly the fish harvesting stage.

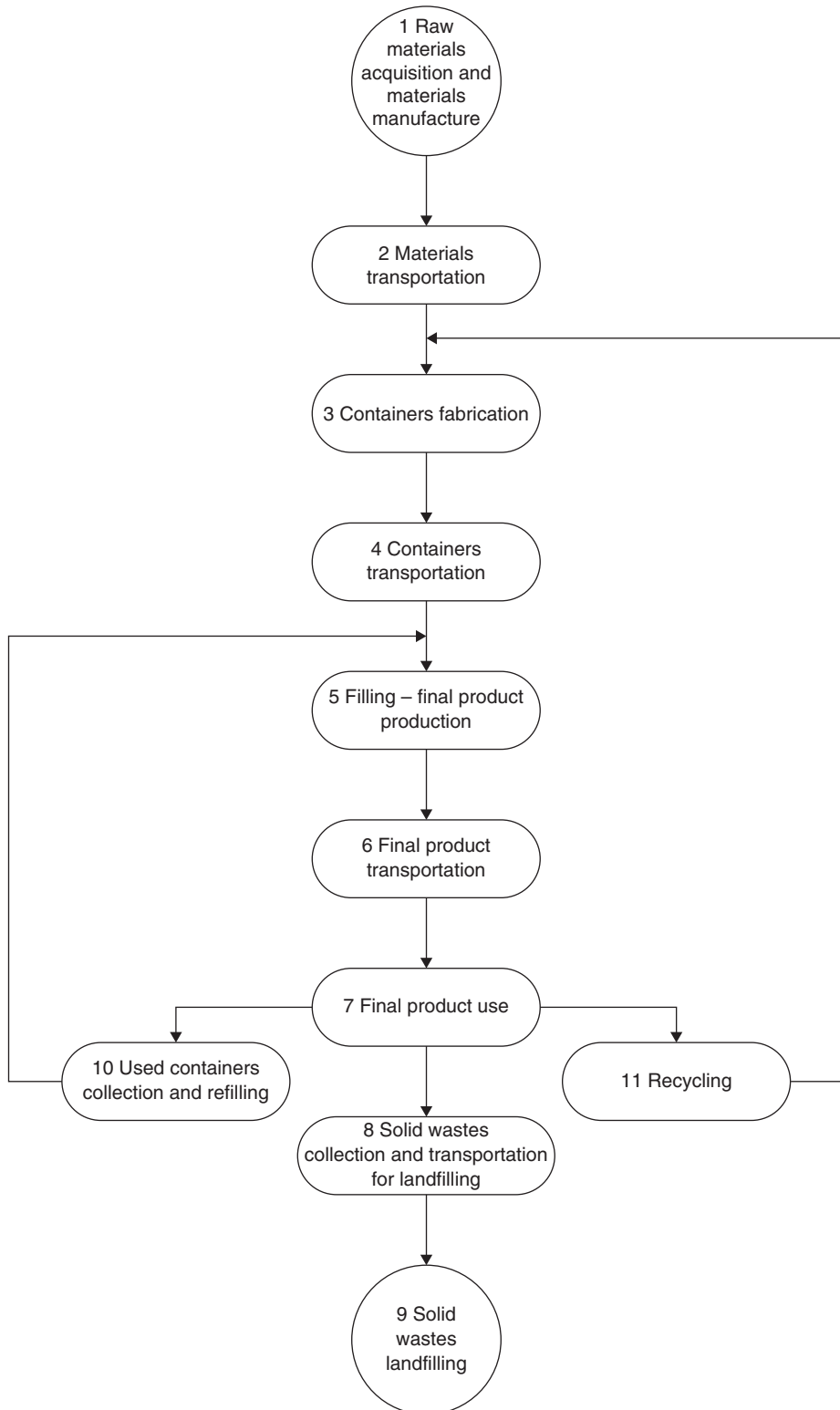

Figure 3.7 The system and its 11 subsystems (adapted from Georgakellos, 2005)

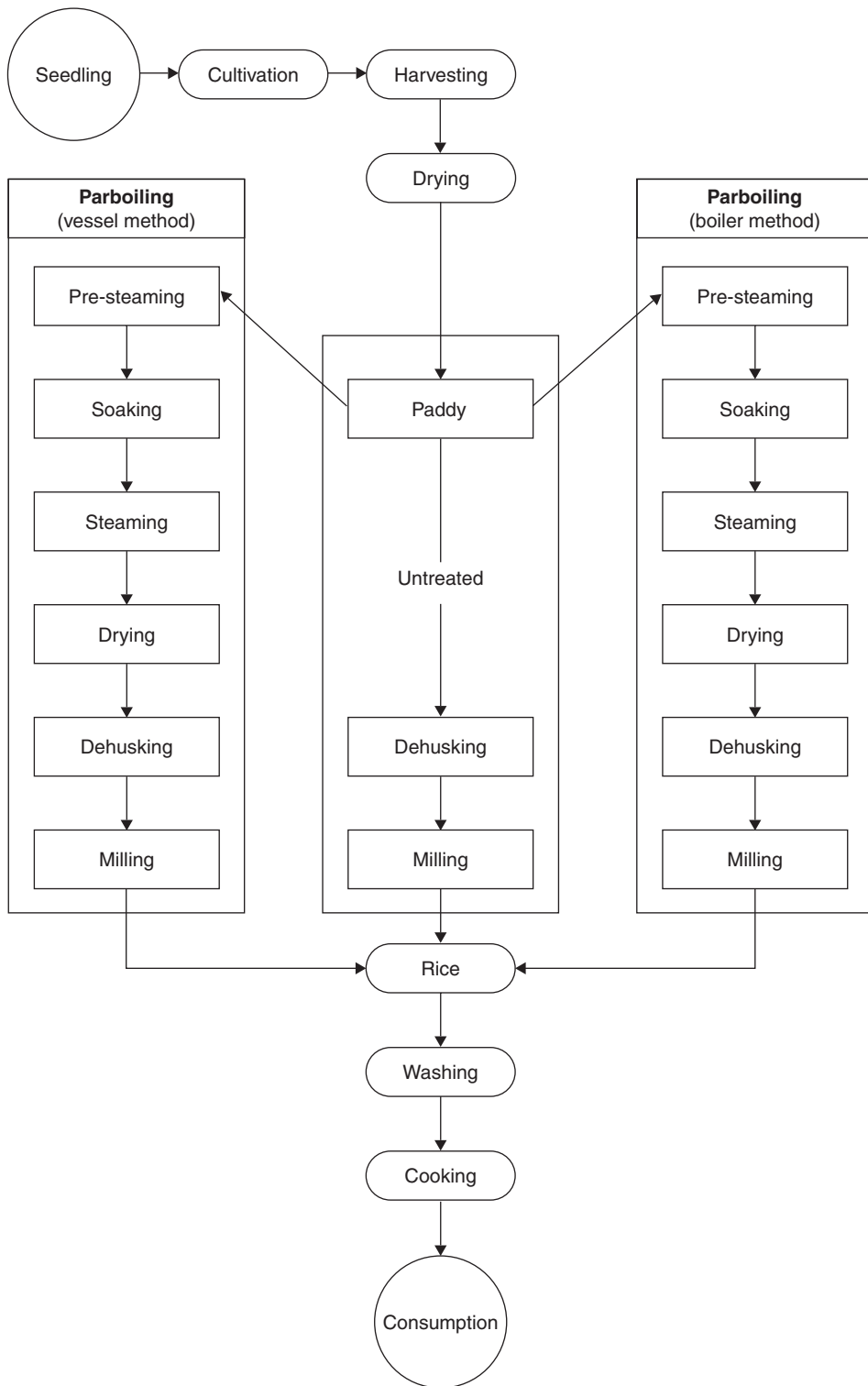

Figure 3.8 Life cycle of rice (adapted from Roy *et al.*, 2006)

Inside the factory, the canned tuna manufacture is divided into seven subsystems, six of which are related to the process itself and the seventh comprises the ancillary activities, such as wastewater treatment and tinplate production for packaging:

- 1 Landing and transport
- 2 Reception, thawing and cutting
- 3 Cooking (key step for quality of the finished product)
- 4 Manual removal of skin, viscera, bones and other useless parts
- 5 Liquid dosage and filling
- 6 Sterilization and cooling in tunnels with steam and dried
- 7 Quality control and packaging
- 8 Assembly shop for cans and easy-open rings as well as the wastewater treatment plant (ancillary activities)
- 9 Labeled transport to wholesale and retail
- 10 Household use (Hospido *et al.*, 2006).

A representative flow diagram of canned tuna production with inputs and outputs at various stages based on LCA principles is given in Figure 3.9. Important reduction is likely to be achieved if changes related to packaging (recycling and composting) are carried out.

An eco-label for fish products caught by energy efficient fishing practices would be one way to promote sustainable fisheries, but authorities should also consider subsidies, fuel taxes, re-distribution of quota and prohibition of certain types of gear. Energy consumption is a key factor contributing to the environmental burden for all investigated fish products. At the fishing stage, the fuel requirement amounts to several liters of fuel per kg caught fish for some species, but the exact figure depends on the applied method for co-product allocation. The qualitative LCA emphasized the importance of the fishing stage, which generally is the main cause for overexploitation of fish stocks, fatal accidents, damage to seafloor habitats, by-catch of sea mammals, and discard. The processing stage only represents an important impact potential for certain types of fish products (pickled herring, canned mackerel and mussels). The latter is partly due to fuel efficient fishing practices and the use of energy intensive packaging materials (Thrane, 2006).

The software SimaPro 6 (System for Integrated Environmental Assessment of PROducts), developed by the Dutch PRé Consultants, was used as the LCA modeling and analysis tool by the University of Cyprus. The software allows modeling and analysis of complex life cycles in a systematic and transparent way, following the recommendations of the ISO 14040 (1997) series of standards. At this stage, the basic model of the olive oil production cycle is built by creating the unit processes identified in concept of the LCA and interconnecting them into an assembly network through 'known outputs to technosphere (products and co-products)'. Since the software only allows the creation of processes with quantified product output flow, in the absence at this stage of quantified flow data, a unit of product output is used for each process. It is highlighted that the model is only preliminary and further development will possibly be required during the implementation of the inventory analysis. A list with the processes used in the model is provided in Table 3.3. There are three types of

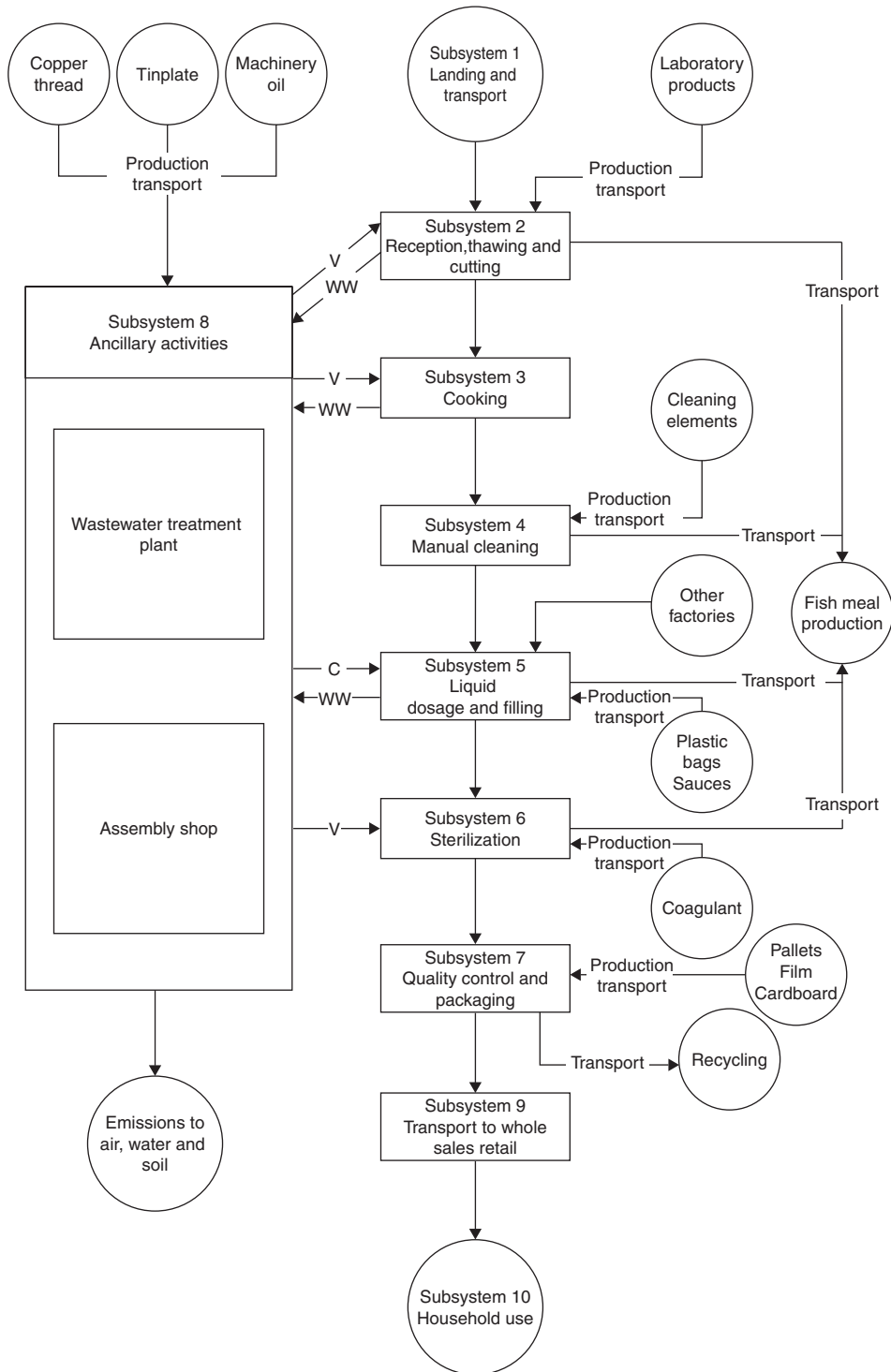

Figure 3.9 System under study: letters with arrows stand for water (W), wastewater (WW), vapor (V) and cans (C) (adapted from Hospido *et al.*, 2006)

Table 3.3 Unit processes included in basic olive oil model

Process category	Unit process	Output to technosphere
Material	Irrigation water supply	Electricity produced (J)
	Irrigation	
	Fertilizer production	
	Fertilizer application	
	Pesticide production	
	Transportation of pesticides to farm	
	Pesticide application	
	Herbicide production	
	Herbicide application	
	Olive collection	
	Water treatment	
	Water supply	
	Olive purification	
	Olive grinding	
	Oil extraction	
Transportation	Transportation of fertilizers to farm	Transported fertilizers, herbicides and olives (tonnes/km)
	Transportation of herbicides to farm	
	Transportation: olive farm to production unit	
Processing	Soil management	Olive trees planted, cultivated and pruned (p)
	Olive tree planting	
	Olive tree cultivation	
	Pruning	Storage time (h)
	Pre-processing olive storage	
Bulk storage of olive oil		
Waste treatment	On-site liquid waste treatment	Waste treated (m ³ or kg)
	Wastewater supplied through network	
	Wastewater treatment (public)	
	Pomace processing	
	Solid waste treatment	

Adapted from <http://www.ecoil,tuc.gr/SimaPro%206.pdf>

inputs. The first type, inputs from nature, refers to inputs that are extracted from natural resources. It is highlighted that this is just referring to the fact that a resource is used, thus the emissions and other environmental impacts to extract the resource should be included in the process. The second input type, inputs from technosphere (materials/fuel) refers to materials and mass flows respectively supplied by other unit processes, whereas the third type, inputs from technosphere electricity/heat refers to non-mass flows including transport and energy supplied by other unit processes. It is highlighted that the only reason SimaPro separates mass and non-mass flows is to allow easier mass balance checks. It is important to highlight that one should only consider potential impacts. Whether the potential materializes will depend on a long series of other factors such as precise fate, exposure, background concentrations and sensitivity of the receiving environment (ecosystems, humans etc.) in the area affected. The impact chain describes the environmental mechanism from 'exchanges' to 'endpoints'.

An ‘endpoint’ is something that one wishes to protect (a value item) such as trees, crops, rivers and human health. A ‘midpoint’ on the other hand, refers to all elements in an environmental mechanism of an impact category that fall between environmental exchanges and endpoints.

Expanded polystyrene (EPS) and corrugated paperboard (CPB) are used in many industrial applications, such as containers, shock absorbers or simply as inserts. Both materials pose two different types of environmental problems. The first is the pollution and resource consumption that occur during the production of these materials; the second is the growing landfills that arise out of the excessive disposal of these packaging materials. The first LCA cradle-to-grave study and impact assessment results highlighted quantitatively the environmental benefits of redesigning the products to consume less material. The next LCA study explored various waste scenarios for EPS and CPB inserts, displaying the positive and negative environmental impacts of land-filling and incineration options, as well as transportation. In conclusion, the least overall damage caused to the environment for the ‘cradle-to-grave’ study of both EPS and CPB comes from increased incineration practices (90–100%) and the worst from landfilling (Tan and Khoo, 2005).

Pulp and paper mills are also among the five major industrial water users in the USA, consuming about 7.5×10^6 m³/day according to Gould (1976). Most of this is discharged into the environment as wastewater from the washing process. Nearly 50% of the wood entering the pulp mill leaves the mill as product paper. Good and Trocino (1979) report that 14 million tons of bark removed each year become a disposal problem since uses of fibers as fuel have been outstripped by production. The greatest percentage of loss in weight from trees to paper is represented by solids, which must be disposed of into the environment. A balanced industrial complex entered a pulp and paper mill as early as 1977 (Nemerow *et al.*, 1977). Timber is brought into the complex to the pulp mill. Major wastes from wood pulp mill are bark, which is burned subsequently in the steam plant, and sulfate waste liquor, which is used in three internal plants: road binder, vanillin and sulfate concentrating. Products from road binder and vanillin can be sold locally or internationally. In all, this complex manufactures six products for external scale: fine paper, wrapping paper, hardboard, vanillin, paperboard and road binder. It also produces four products for internal use: concentrated sulfate, wood pulp, wrapping paper and groundwood pulp. In addition, all the major wastes of suspended solids, cooking liquor, fillers, heat and bark are reused within the complex in the manufacturing of these products. The solids concentration of spent sulfate liquor waste from the pulp mill digester will vary from 6% to 16%, with an average value of 11%. These solids may contain as much as 68% liquosulfonic acid, 20% reducing sugars and 6.8% calcium. Complete evaporation of sulfate waste liquor produces a fuel that can either be burned without an additional outside fuel supply or yield a salable by-product such as synthetic vanillin or road binder (Nemerow, 1995). The overall potential production of Kraft papers of different quality is presented in Figure 3.10.

New human population intake fractions after emission to rural and urban air are systematically higher compared to the previous model calculations. A higher human population intake fraction via inhalation, resulting from a longer modeled residence time of chemicals in air caused by the inclusion of no rain conditions, clarifies this

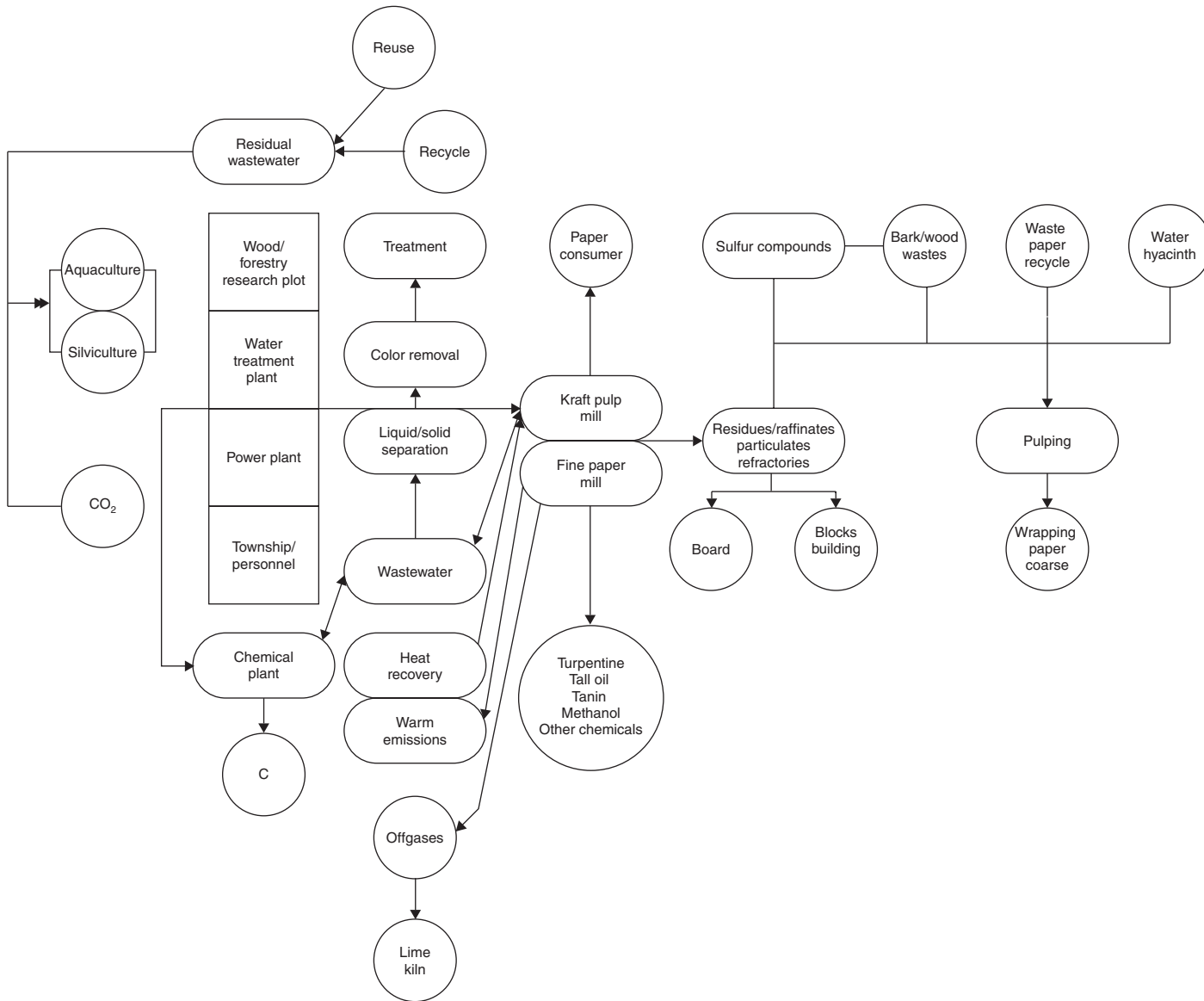

Figure 3.10 Environmentally balanced pulp and paper complex (adapted from Nemerow, 1995)

systematic difference. It was also shown that the new human population intake fractions after emission to industrial soil are systematically higher (factor of 6) compared to the previous model calculations. This can be explained by the fact that a higher runoff rate from industrial soil to surface water is assumed, resulting in higher surface water concentrations and consequently drinking water and fish concentrations in the new model version. However, after emission to agricultural soil the human population intake fractions are systematically lower (factor of 10) compared to the previous model calculations.

The new fate factors of the marine environment are systematically higher due to the assumed lower degradation rates in seawater compared to freshwater (Huijbregts *et al.*, 2005).

Another study assessed the relative impacts of pest-control methods in greenhouses, based on current LCA tools. As a case study, the relative impacts of two tomato production methods, chemical pest management (CPM) and integrated pest management (IPM), were assessed. The amount of the active ingredient applied, the fate of the ingredients in the various greenhouse and environmental compartments, the human exposure routes via the various compartments and the inherent toxicity of the ingredients were taken into account in the relative impact calculations. The importance of model selection in the assessment pesticide-specific fate and exposure factors for humans and aquatic and terrestrial ecosystems, used to aggregate pesticide emissions, was calculated with two different models:

- 1 the USES-LCA model, adapted in order to calculate the pesticide transfer from greenhouse air and soil to fruits
- 2 the empirical model critical surface time (CST).

Impact scores have in general shown a higher level of potential contamination in greenhouses treated with CPM compared to IPM (a factor of 1.4 to 2.3) (Anton *et al.*, 2004).

The development of methodologies to assess the effects of pesticides in a consistent way and to enable comparison with the impacts from other agricultural practices is urgently needed. LCA is used to determine the impact of pesticides on human health and ecosystems. The approach considers a full-fate analysis and the exposure to toxic pollutants through different media and pathways, including residues in food, based on the behavior of the pesticides in air and the importance of transfers between soil and surface or groundwaters. For human toxicity, estimates of pesticide residues show that food intake results in the highest toxic exposure, about 10^3 to 10^5 times higher than that induced by drinking water or inhalation. Better evaluation practices of pesticide residues in food need to be established in priority. For the 'no effect concentration (NEC)' used as a reference for both terrestrial and aquatic ecotoxicity, extrapolation methods are developed on the basis of experimental data. Extrapolation coefficients for risk assessment are to be used with caution; an intra-species extrapolation factor of 10 explained the relationship between acute (LC_{50}) and chronic (NOEC) ecotoxicity, whereas it was not suitable for inter-species extrapolation. The method was applied to five fungicides that have the same function on wheat. It was demonstrated that the comparison of pesticides is feasible, the pollution sources of highest concern being identifiable and the

best environmental management practices thereby promoted without penalizing the crop itself. Relative impacts have been shown to be highly dependent on the selection of specific pesticides and crop stage development at the moment of pesticide application. This means that both CPM and IPM could be improved by a careful selection of pesticides (Margni *et al.*, 2002).

Environmental sustainable corporate performance (SCP) often focuses on events at a local level. The enormous number of indicators found in the literature generates numerous data that often provide no additional knowledge on the environmental sustainability of a system. Overall environmental implications of food production are therefore poorly understood. The proposed measuring method uses three indicators that address global environmental issues: the use of energy (from both fossil and renewable sources), land and water. The systematic approach can calculate trade-offs along supply chains that make up a production system. The use of the method implies an extension of environmental SCP towards the overall performance of a production system. The final outcome is expressed in three performance indicators: the total land, energy and water requirement per kilogram of available food. For companies, the data generated can be used to compare trends over time, to compare results with targets and to benchmark a company against others. For consumers, data can be used to compare the environmental effects of various foods. The method is also applicable to other business sectors (Gerbens-Leenes *et al.*, 2003).

In alumina production, also commonly named alumina refining, bauxite is converted to aluminum oxide using the Bayer process, which uses caustic soda and calcined lime (limestone) as input reactants. Bauxite is ground and blended into a liquor containing sodium carbonate and sodium hydroxide. The slurry is heated and pumped to digesters, which are heated pressure tanks. In digestion, iron and silicon impurities form insoluble oxides called bauxite residue. The bauxite residue settles out and a rich concentration of sodium aluminate is filtered and seeded to form hydrate alumina crystals in precipitators. These crystals are then heated in a calcining process. The heat in the calciners drives off combined water except for alumina. Fresh water (input taken conservatively whether the water used is from fresh, underground, mine waste water, etc. sources) or seawater is used as cooling agent. The major differences in processing are at the calcination stage. Two types of kilns are used: rotary and fluid bed. The fluid bed or stationary kiln is newer and significantly more energy efficient. Energy requirements (coal, diesel oil, heavy oil, natural gas and electricity) have almost been halved over the last 15 years with the introduction of higher pressure digesters and fluid flash calciners. Air emissions mostly arise from the calcination stage (particulates; NO_x (as NO_2), SO_2 , from fuel combustion; mercury found in bauxite ores), while water emissions come from cooling use (fresh water, seawater, oil/grease) or are linked with the digestion stage (suspended solids, mercury found in bauxite ores). Most of the bauxite residue currently turns out as solid waste, while a small but growing fraction is reused. Other by-products for external recycling are reaction chemicals. Other landfill wastes are typically inert components from bauxite such as sand or waste chemicals (International Aluminium Institute, 2003).

Keoleian and Kar (2003) used the LCD framework to evaluate three air intake manifold designs: a sand cast aluminum, brazed aluminum tubular and nylon composite.

Life cycle inventory, life cycle cost and product/process performance analyses highlighted significant trade-offs among alternative manifolds, with respect to system design requirements. The life cycle inventory indicated that the sand-cast aluminum manifold consumed the most life cycle energy (1798 MJ) compared to the tubular brazed aluminum (1131 MJ) and nylon composite (92 MJ) manifolds. The cast aluminum manifold generated the least life cycle solid waste of 218 kg per manifold, whereas the brazed aluminum tubular and nylon composite manifolds generated comparable quantities of 418 kg and 391 kg, respectively. Material production accounted for 70% of the total life cycle solid waste for the brazed tubular manifold, while auto shredder residue was responsible for half the total waste for the nylon composite design. The life cycle cost analysis estimated Ford manufacturing costs, customer gasoline costs and end-of-life management costs. The nylon composite manifold had the highest estimated manufacturing costs but the least use phase gasoline costs. Significant end-of-life management revenues from aluminum recycling would accrue to Ford under automobile take back legislation. A total of 20 performance requirements were used to evaluate each design alternative. Table 3.4 shows that the life cycle costs of the two aluminum manifolds are similar. The life cycle cost of the composite manifold is approximately \$10.76 more than that of the aluminum manifolds. The material cost of a sand-cast manifold is about \$5.23 higher than that of multitube brazed and \$6.87 higher than composite manifold. The higher material cost of a sand-cast manifold is due to its higher weight compared to a multitube brazed manifold.

The final studies of this chapter are two handbooks of guidelines and checklists for the eco-efficient development of two types of vending machines: one for snack and food (spirals model), the other for hot and cold drinks. In order to achieve these results, an LCA has been developed and a system to prioritize guidelines has been adopted; this system has led to a procedure which moves from general to specific guidelines and checklist. Finally, these tools have been integrated within the company procedure. The adopted design criteria were: energy reduction in use, product and components life extension, materials life extension, design for disassembly, material consumption reduction, toxicity reduction, conservation and bio-compatibility. For each of these design

Table 3.4 Life cycle costs of intake manifolds (in US dollars)

	Composite		Sand-cast	
	US	German	US	German
Material cost	6.01	6.01	12.38	12.38
<i>Manufacturing cost</i>				
Fixed	3.90	3.90	2.70	2.70
Variable	50.16	50.16	38.66	38.66
Use phase costs	4.47	11.90	10.52	28.16
End-of-life costs	0.42	0.42	1.81	1.81
Salvage value	0.68	0.58	5.93	5.93
Life cycle cost	58.27	65.70	47.76	65.40

Adapted from Keoleian and Kar, 2003

criteria, a priority indicator was computed according to their potential of environmental improvement (relative to the other criteria). The highest priority was defined (normalized) as 100; the lower values indicated the relative lower priorities (Vezzoli and Sciama, 2006).

The methodology applied to evaluate the environmental performance of each alternative is life cycle assessment (LCA). The analysis has been performed at two levels; first, the emissions accounted for in the inventory stage have been arranged into impact categories to obtain an indicator per category; and secondly, weighing of environmental data to a single unit was applied. Despite quantitative differences between the results obtained with four alternative impact assessment methods, the same preference ranking has been established: scenarios with energy recovery 1v – this scenario emphasizes the recovery of the putrescible fraction. The household waste is source separated into three fractions: putrescible, restwaste and recyclable – and 2v – emphasis on quality of the recovered materials, both organics and inorganics and the household waste is source separated into four fractions: putrescible, inorganic, restwaste and recyclable – achieve major improvements compared to baseline, with scenario 1v being better than 2v for all impact assessment methods except for the EPS'00 method, which obtains better results for scenario 2v (Table 3.5) (Bovea and Powell, 2006).

A novel indicator aiming at characterizing the renewability of (bio)energy sources is proposed – the energy renewability efficiency (ERenEf). ERenEf measures the fraction of final fuel energy obtained from renewable sources. Inventory results – calculated using four different allocation approaches and ignoring co-product credits – are analyzed in order to understand the effect of allocation in the energy efficiency and renewability results. Sensitivity analysis shows that allocation has a major influence on the results. This research concludes that bioethanol produced in France is clearly favorable in terms of primary energy. A maximum ERenEf value of 48% was obtained for wheat-based ethanol (mass allocation), meaning that 48% of the biofuel energy content is indeed renewable energy. Fossil energy savings when gasoline is displaced by bioethanol, bioETBE or E5 are calculated. In particular, pure bioethanol may save up to 0.70 MJ, depending on whether wheat or sugar beet is used and on the allocation procedure adopted. The production route of ethanol from wheat (Figure 3.11) includes a sequence of mechanical and chemical processes, which can be divided in two main stages. First, feedstock processing, including grinding of grains, liquefaction and saccharification, where enzymes are introduced to break down the starch in the wheat into

Table 3.5 Results of impact assessment methods

	Reprocessing (%)	Compost (%)	Landfill (%)
Scenario 0 (Baseline) current situation	10.5	13.4	55.0 without energy recovery
Scenario 1v	23.3	19.0	37.7 with/without energy recovery
Scenario 2v	24.2	19.0	36.8 with/without energy recovery

Adapted from Bovea and Powell, 2006

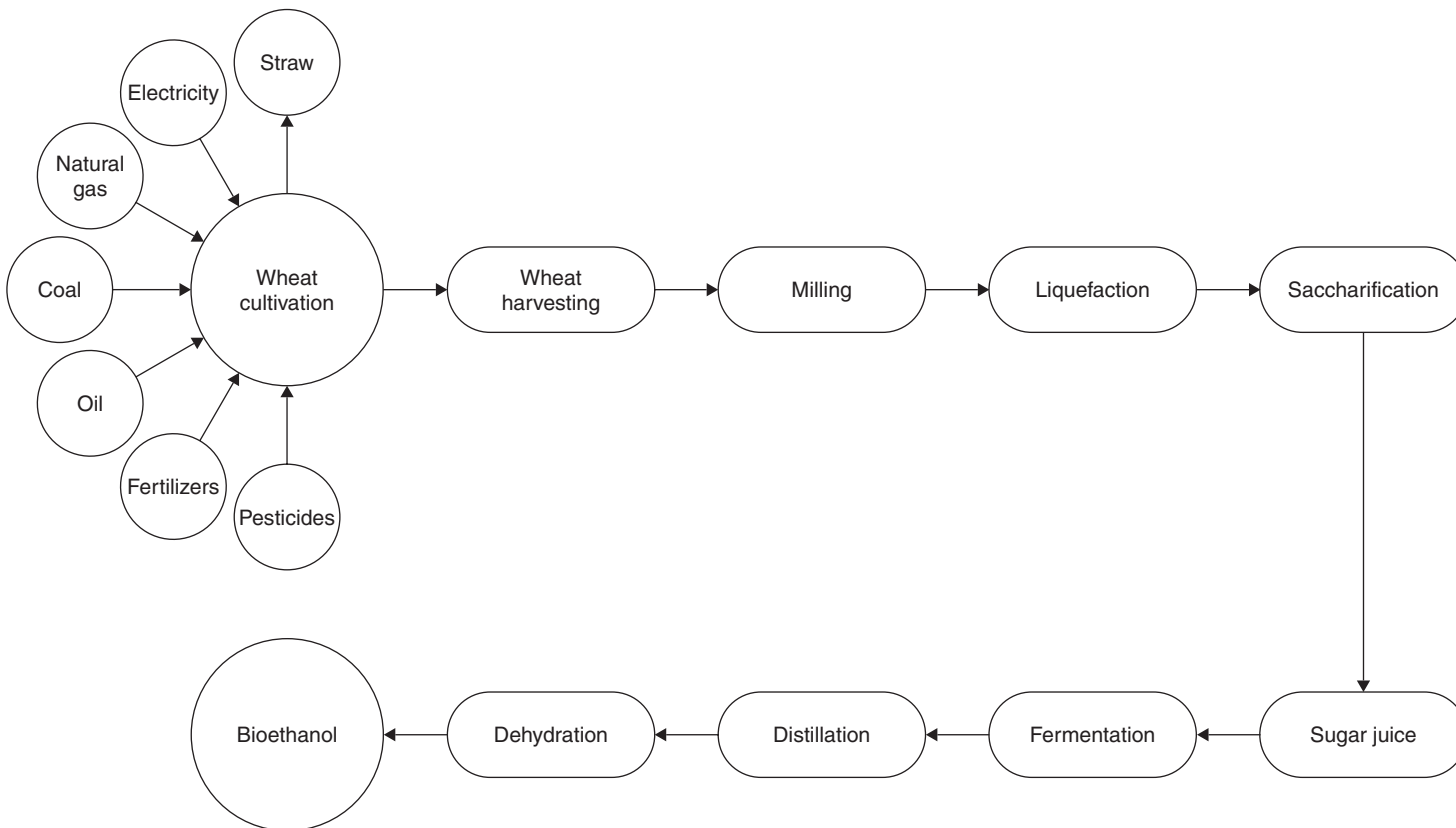

Figure 3.11 Flow chart illustrating the bioethanol production chain from wheat (adapted from Malca and Freire, 2006)

fermentable sugar. Secondly, fermentation of sugar juice using yeast to produce ethanol at 10–15% concentration, distillation of this solution to recover the ethanol at higher concentrations (95%) and dehydration to obtain anhydrous ethanol used as fuel. The leftover residue from the fermentation process (distiller's dried grains with solubles (DDGS)) is the wheat equivalent of pulps from sugar beet but with higher protein content and can be sold as high-protein animal feed (Malca and Freire, 2006). The results demonstrated that the LCEA of wheat-based ethanol is highly sensitive to the allocation method used. In fact, ERenEf values for bioethanol (wheat) can vary more than 50%, ranging between -10% (replacement method) and 48% (mass allocation), with 31% for energy allocation and 46% for allocation based on market values. However, the energy renewability efficiency of ethanol from sugar beet varies only between 33% and 37%, being less sensitive to allocation because, in this case, co-production is not very relevant. ERenEf values calculated ignoring co-product credits can be very low, emphasizing the importance of performing allocation. Regardless of the kind of biofuel (pure or blended) assessed in this research, actual fossil energy savings are achieved in comparison to gasoline, even though to different extents depending on the fraction of bioethanol in the final commercial blend. Energy savings per MJ of FEC range from 0.02MJ (E5) to 0.70MJ (bioethanol).

Sarmah and coworkers (2006) reported on the veterinary antibiotics entering the environment through manufacturing plants, process effluents, disposal of unused or expired compounds, overland flow runoff, unsaturated zone transport from fields to which agricultural waste has been applied, and through leaky waste-storage structures (Figure 3.12). The importance of the individual pathways of these compounds into the environment varies and depends primarily on the waste storage, manure field application practices and the type of antibiotic used. It has been reported that in some cases, as much as 80% of the antibiotics administered orally to livestock, pass through the animal unchanged into bacteria-rich waste lagoons and is then spread on agricultural fields as a source of fertilizer (USEPA, 2000). The amounts of antibiotics excreted vary with the type of antibiotic, the dosage level, as well as the type and the age of animal (Katz, 1980). Studies on the occurrence, fate and transport of pharmaceutical compounds in the environment are comparatively recent and a number of these compounds have been detected in sewage effluents and surface waters, as well as in drinking water (Ternes, 1998; Hirsch *et al.*, 1999; Stumpf *et al.*, 1999; Kolpin *et al.*, 2002; McArdell *et al.*, 2003). Although the majority of these studies reported the occurrence of human pharmaceuticals, there are instances where animal antibiotics have been found in surface and groundwaters and in marine sediments.

LCA in the future

Nowadays, there is an increasing awareness that today's life style should aim at more sustainable production schemes in conjunction with limited use of renewable resources and minimal environmental impact on land, water and air (Environment in <http://www.tc207.org/articles/>). All processes have to be envisaged as potential

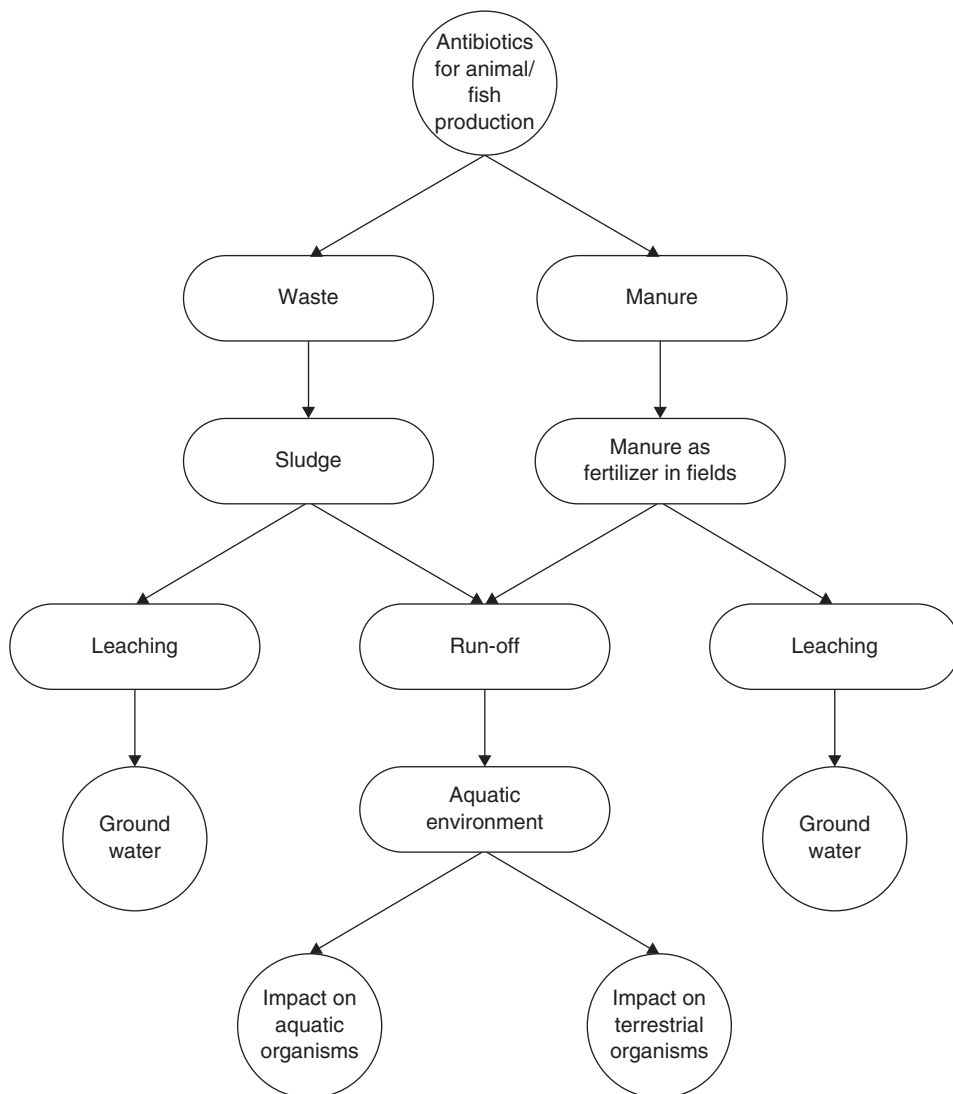

Figure 3.12 Anticipated exposure pathways for veterinary antibiotics in the environment (adapted from Sarmah *et al.*, 2006)

resources since their by-products provide the primary material for a subsequent process in a continuous regenerative loop (Tansey and Worsley, 1995). Life cycle assessment, though not a brand new tool any more, is still able to analyze and assess the environmental impacts associated with a product, process or service by multi-attribute product evaluations. The importance of LCA as an environmental decision support tool continues to increase rapidly. A distinction between the objective and subjective elements of LCA is bound to take place in order to clarify the structure of the method and be of great help to the decision-making. Goal definition and scoping as well as interpretation of the inventory results would benefit most from decision

analytic approach and methods. In these phases, subjectivity and the overall goal of the process have a major impact. The important dimensions of the decision problem could be presented in a value tree and this could be exposed to general discussion and modification before deciding the actual content and scope of the study. Pertinent answering of the prioritization questions at an early stage of the study is anticipated to help greatly the decision-makers in terms of identifying both the real decision alternatives and the concrete environmental problems closely linked with the product's environmental impacts thus providing the required inventory data. Valuation referring to values is another subjective issue and is closely linked to preference data (Miettinen and Hamalainen, 1997).

References

- Andersson, K., Ohlsson, T. and Olsson, P. (1994). Life cycle assessment (LCA) of food products and production systems. *Trends Food Sci Technol* **5**, 134–138.
- Andersson, K. and Ohlsson, T. (1999). Including environmental aspects in production development: a case study of tomato ketchup. *Lebensm-Wiss u-Technol* **32**, 134–141.
- Anton, A., Castells, F., Montero, J.I. and Huijbregts, M. (2004). Comparison of toxicological impacts of integrated and chemical pest management in Mediterranean greenhouses. *Chemosphere* **54**, 1225–1235.
- Ayalon, O., Avnimelecha, Y. and Shechter, M. (2000). Application of a comparative multidimensional life cycle analysis in solid waste management policy: the case of soft drink containers. *Environ Sci Pol* **3**, 135–144.
- Azapagic, A. (1999). Life cycle assessment and its application to process selection, design and optimisation. *Chem Engine J* **73**, 1–21.
- Berlin, J. (2002a). Environmental life cycle assessment (LCA) of semi-hard cheese. *Int Dairy J* **12**, 939–953.
- Boudouropoulos, I. and Arvanitoyannis, I.S. (2000). Potential and perspectives for application of environmental management system (EMS) and ISO 14000 to food industries. *Food Rev Int* **16**(2), 177–237.
- Boudouropoulos, I. and Arvanitoyannis, I.S. (1999). Current state and advances in the implementation of ISO 14000 by the food industry. Comparison of ISO 14000 to ISO 9000 to other environmental programs. *Trends Food Sci Technol* **9**, 395–408.
- Bovea, M.D. and Powell, J.C. (2006). Alternative scenarios to meet the demands of sustainable waste management. *J Environ Manage* **79**, 115–132.
- Cederberg, C. and Mattson, B. (2000). Life cycle assessment of milk production – a comparison of conventional and organic farming. *J Cleaner Prod* **8**, 49–60.
- De Monte, M., Padoano, E. and Pozzetto, D. (2005). Alternative coffee packaging: an analysis from a life cycle point of view. *J Food Engine* **66**, 405–411.
- Ellingsen, H. and Aanonsen, S.A. (2006). Environmental impacts of wild caught cod and farmed salmon – a comparison with chicken. *Int J LCA* **11**(1), 60–65.
- Environment–First Principles for Environmental Life Cycle Assessment Reprinted with the permission of ISO Bulletin, *Technical Committee 207* <http://www.tc207.org/articles/>.

- EPA (1994). EPA pollution prevention accomplishments 1993, policy leads to action. EPA Publication Number EPA-100-R-94-002. US Environmental Protection Agency, Office of the Administrator, Washington, DC.
- Gerbens-Leenes, P.W., Moll, H.C. and Schoot Uiterkamp, A.J.M. (2003). Design and development of a measuring method for environmental sustainability in food production systems. *Ecol Econ* **46**, 231–248.
- Georgakellos, D.A. (2005). Evaluation of life cycle inventory results using critical volume aggregation and polygon-based interpretation. *J Cleaner Product* **13**, 567–582.
- Good, R.D. and Trocino, F.S. (1979). Fir bark conversion route. *Process Technology and Flow Sheets*. McGraw-Hill, New York.
- Gould, M. (1976). Water pollution control in the paper and allied products industry. *Industrial Wastewater Management Handbook*. McGraw-Hill, New York.
- Grob, G.R. (2003). Importance of ISO and IEC international energy standards and a new total approach to energy statistics and forecasting. *Appl Energy* **76**, 39–54.
- Grotz, S. and Scholl, G. (1996). Application of LCA in German industry. *Int J LCA* **1**(4), 226–230.
- Gysi, C. and Reist, A. (1990). Hors-sol Kulturen – eine ökologische Bilanz. *Landwirtsch Schweiz* **3**(8), 447–459.
- Haas, G., Wetterich, F., and Kopke, U. (2001). Comparing intensive, extensified and organic grassland farming in southern Germany by process life cycle assessment. *Agricult Ecosyst Environ* **83**(1–2), 43–53.
- Hahn, S. (1992). Applicability of LCA in food chain. *PhD Thesis*. Universiteit des Landes Hessen, Witzenhausen.
- Haklik, J.E. (1998). ISO 14001 and sustainable development. *Transformation strategies*, <http://www.trst.com>.
- Heijungs, R. (1992). Environmental life cycle assessment of products, backgrounds, October 1992. CML, Leiden University, Leiden.
- Hirsch, R., Ternes, T., Haberer, K. and Kratz, K.L. (1999). Occurrence of antibiotic in the aquatic environment. *Sci Total Environ* **225**, 109–118.
- Hogaas, M. (2002). Life cycle assessment of industrial milk production. *Int J LCA* **7**(2), 115–126.
- Hospido, A., Moreira, M.T. and Feijoo, G. (2003). Simplified life cycle assessment of galician milk production, *Int Dairy J* **13**, 783–796.
- Hospido, A. and Tyedmers, P. (2005). Life cycle environmental impacts of Spanish tuna fisheries. *Fish Res* **76**, 174–186.
- Hospido, A., Vazquez, M.E., Cuevas, A., Feijoo, G. and Moreira, M.T. (2006). Environmental assessment of canned tuna manufacture with a life-cycle perspective. *Resources Conservat Recyc* **47**, 56–72.
- Huijbregts, M.J., Struijs, J., Goedkoop, M., Heijungs, R., Hendriks, A.J. and Van de Meent, D. (2005). Human population intake fractions and environmental fate factors of toxic pollutants in life cycle impact assessment. *Chemosphere* **61**, 1495–1504.
- International Aluminium Institute, Vigon (2003). Annual Report.
- IOW Wien (1992). In *Methodenteil zum Forschungsprojekt Okobilanzen für die Konservenindustrie*. Schriftenreihe, Vienna 13/1992, IOW Wien.

- Jolliet, O. (1998). Life cycle impact assessment of pesticides on human health and ecosystems. In *Life cycle assessment in agriculture* (D. Ceuterik, ed.), pp. 109–119. Agro-industry and Forestry, VITO, mol, Helsinki.
- Jolliet, O. (1993). Bilan écologique de la production de tomates en serre. *Rev Suisse Viticult Arboricult Horticult* **25**, 261–267.
- Jolliet, O., Cotting, K., Drexler, C. and Farago, S. (1996). *Agriculture, Ecosystems and Environment*. Elsevier, Amsterdam.
- Katz, S.E. (1980). The effects of human health. In *Subtherapeutic use of antimicrobials in animal feeds*. National Academy of Sciences, Washington, DC.
- Keoleian, G.A. and Kar, K. (2003). Elucidating complex design and management trade-offs through life cycle design: air intake manifold demonstration project. *J Cleaner Product* **11**, 61–77.
- Kolpin, D.W., Furlong, E.T., Meyer, M.T. *et al.* (2002). Pharmaceuticals, hormones and other waste water contaminants in US streams 1999–2000. A national reconnaissance. *Environ Sci Technol* **36**, 1202–1211.
- Kooijman, J.M. (1993). Environmental assessment of packaging: sense and sensibility. *Environ Manage* **17**(5), 575–586.
- Koroneos, C., Roumbas, D., Gabari, Z., Papagiannidou, E. and Moussiopoulos, N. (2005). Life cycle assessment of beer production in Greece. *J Cleaner Product* **13**, 433–439.
- Kuhre, W.L. (1995). *ISO 14010s Environmental auditing*. Prentice-Hall, New Jersey.
- Lundie, S. and Peters, G.M. (2005). Life cycle assessment of food waste management options. *J Cleaner Product* **13**, 275–286.
- Malca, J. and Freire, F. (2006). Renewability and life-cycle efficiency of bioethanol and bio-ethyl tertiary butyl ether (bioETBE): Assessing the implications of allocation. *Energy* **31**, 3362–3380.
- Margni, M., Rossier, D., Crettaz, P. and Jolliet, O. (2002). Life cycle impact assessment of pesticides on human health and ecosystems. *Agricult Ecosystems Environ* **93**, 379–392.
- McArdell, C.S., Molnar, E., Suter, M.J.F. and Giger, W. (2003). Occurrence and fate of macrolide antibiotics in wastewater treatment plants and in the Glatt valley watershed, Switzerland. *Environ Sci Technol* **37**, 5479–5486.
- Miettinen, P., Raimo, P. and Hamalainen, R.P. (1997). How to benefit from decision analysis in environmental life cycle assessment (LCA). *Eur J Operational Res* **102**, 279–294.
- Nemerow, N.L. (1995). *Zero pollution for industry. Waste minimization through industrial complexes*. Wiley-Interscience Publication, New York.
- Nemerow, N.L., Farooq, S. and Sengupta, S. (1977). Industrial complexes and their relevances for pulp and papermills. *Environ Int* **3**(1), 65–68.
- Oosterhuis, F., Rubik, F. and Scholl, G. (1996). *Product policy in Europe: new environmental perspectives*. Kluwer Academic Publishers, Dordrecht.
- Ott, D. (1992). LCA in packaging materials. *Msc Thesis*. Fachhochschule Hamburg.
- Pedersen, B. (1992). Udvikling af Kvalitetsstandareder for Forarbejdede Okologiske Fodevater. Technical University of Denmark.
- Pennington, D.W., Potting, J., Finnveden, G. *et al.* (2004). Life cycle assessment Part 2: Current impact assessment practice. *Environ Int* **30**, 721–739.

- Rob, P. (1996). Life-cycle analysis on recycling and recovery of post-consumer plastics. Association of Plastic Manufacturers in Europe, 1996 January.
- Ross, S. and Evans, D. (2003). The environmental effect of reusing and recycling a plastic-based packaging system. *J Cleaner Prod* **11**, 561–571.
- Roy, P., Shimizu, N., Okadome, H., Shiima, T. and Kimura, T. (2007). Life cycle of rice: challenges and choices for Bangladesh. *J Food Eng* **79**(4), 1250–1255.
- Roy, P. (2003). Improvement of energy requirement in traditional parboiling process. PhD thesis, University of Tsukuba, Japan (unpublished).
- Rubik, F. (1997). Themen, Initiatoren, Methoden, Summaries und Anwendungen-Wohin bewegen sich Produkt-Oekobilanzen? In UTECH Berlin '97: Produktbezogene Oekobilanzen V. Berlin: 19–20 February 1997, pp. 29–50.
- Sarmah, A.K., Meyer, M.T. and Boxall, A.B.A. (2006). A global perspective on the use, sales, exposure pathways, occurrence, fate and effects of veterinary antibiotics (VAs) in the environment. *Chemosphere* **65**(5), 725–759.
- Scholl, G.U. and Nisius, S. (1998). The environmental benefits to German companies through application of LCA. *J Cleaner Prod* **6**, 247–252.
- SETAC (1993) Life cycle assessment in http://www.setac.org/htdocs/who_intgrp_lca.html (Accessed 06 Dec. 2006).
- Sonesson, U. and Berlin, J. (2003). Environmental impact of future milk supply chains in Sweden: a scenario study. *J Cleaner Prod* **11**, 253–266.
- Stumpf, M., Ternes, T.A., Rolf-Dieter, W., Rodrigues, S.V. and Baumann, W. (1999). Polar drug residues in sewage and natural waters of Rio de Janeiro, Brazil. *Sci Total Environ* **225**, 135–141.
- Tan, R.B.H. and Khoo, H.H. (2005). Life cycle assessment of EPS and CPB inserts: design considerations and end of life scenarios. *J Environ Manage* **74**, 195–205.
- Tansey, G. and Worsley, T. (1995). *The food system: a guide*. Earthscan Publ. Ltd, London.
- Ternes, T.A. (1998). Occurrence of drugs in German sewage treatment plants and rivers. *Water Res* **32**, 3245–3260.
- Thrane, M. (2004). Environmental impacts from Danish fish products: hot spots and environmental policies (doctoral thesis). Alborg University, Alborg.
- Thrane, M. (2006). LCA of Danish fish products new methods and insights. *Int J LCA* **11**(1), 66–74.
- Tibor, T. and Feldman, J. (1997). Implementing ISO 14000. In *Implementing ISO 14000*. Irwin Profess Library Publication.
- University of Cyprus. LCA of olive oil using SimaPro 6. (<http://www.ecoil,tuc.gr/SimaPro%206.pdf>)
- USEPA (United States Environmental Protection Agency) (2000). National management measures to control non-point pollution from agriculture. Office of water, Non-point Source Control Branch, Draft report.
- Vezzoli, C. and Sciamia, D. (2006). Life cycle design: from general methods to product type specific guidelines and checklists: a method adopted to develop a set of guidelines/checklist handbook for the eco-efficient design of NECTA vending machines. *J Cleaner Prod* **14**, 1319–1325.
- Vigon, B.W. and Jensen, A.A. (1995). Life cycle assessment: data quality and databases practitioner survey. *J Cleaner Prod* **3**(3), 135–141.

- Vis, J., Krozer, J., van Durse, P. and Koudijs, H. (1992) *Milieumaten van Margarine + een Oeffenproject*.
- Zabaniotou, A. and Kassidi, E. (2003). Life cycle assessment applied to egg packaging made from polystyrene and recycled paper. *J Cleaner Prod* **11**, 549–559.
- Ziegler, F., Nilsson, P., Mattsson, B. and Walther, Y. (2003). Life cycle assessment of frozen cod filets including fishery-specific environmental impacts. *Int J LCA* **8**(1), 39–47.

Environmental Legislation

PART

2

- | | | |
|---|---|-----|
| 4 | Presentation and Comments on EU Legislation Related to Food Industries – Environment Interactions | 135 |
| 5 | Presentation and Comments on USA and Canada Legislation Related to Food Industries – Environment Interactions | 289 |

This page intentionally left blank

Presentation and Comments on EU Legislation Related to Food Industries – Environment Interactions

*Ioannis S. Arvanitoyannis, Persefoni Tserkezou and
Stefania Choreftaki*

Introduction	135
Topics/categories covered under EU legislation	138

Introduction

The goal of European waste-related legislation is to protect public health and the environment and, so far, it has had a significant impact. However, given the lack of precision of the definition of waste in the European Community Directive (European Council, 1993), each Member State makes a different interpretation of the definition of waste with regard to specific materials, resulting in trade barriers and the impact of this upon the recycling industry is not to be underestimated. Under the present European definition of waste, recoverable material is seen more as a potential pollutant than as a potential raw material (Bontoux and Leone, 1997). Thanks mainly to the legislative actions of the European Union (EU), the importance attached to environmental protection and awareness is being increasingly recognized across Western European nations. The Urban Waste Water Treatment Directive, one of the main pillars of the existing EU legislation on wastewater, has already been incorporated into national law in all Member States and is necessitating investment at both municipal and industrial level in

appropriate technology, including solid/liquid separation units. The Western European solid/liquid separation market was found to have amassed revenues worth 1.63 billion Euros in 2000 and demand for new and replacement equipment is expected to maintain growth rates in the short and medium term. The impressive range of applications using solid/liquid separation equipment is forecast to overcome the problem of competitive pricing in many market sectors, producing a Western European market valued 2.13 billion Euros by 2007 (Frost and Sullivan, 2001). According to Pongrácz and Pohjola (1997) waste can be classified into four classes:

- 1 Class 1: non-wanted things created not intended, or not avoided, with no purpose
- 2 Class 2: things that were given a finite purpose thus destined to become useless after fulfilling it
- 3 Class 3: things with well-defined purpose, but their performance ceased being acceptable
- 4 Class 4: things with well-defined purpose and acceptable performance, but their users failed to use them for the intended purpose.

Although incineration is an effective way of treating municipal solid waste, the potential public health effects associated with stack emissions have become a major public concern. Some of the chemicals emitted are constituents of the waste, which move through the combustion chamber and are not captured by pollution control devices. Chemicals like polychlorinated dibenzo-p dioxins and furans (PCDD/Fs) emitted into the atmosphere as air emissions are directly transmitted to humans through inhalation. However, these chemicals can also be distributed in various media such as soil, vegetation, water, biota, etc. Therefore, human health can be indirectly affected through different pathways, such as drinking water or groundwater, skin absorption of the chemicals present in water, consuming contaminated foodstuffs and through ingestion and skin absorption of those chemicals adsorbed to soil (Meneses *et al.*, 2004).

Human health risk assessment requires identification of the pathways through which people can be potentially exposed to the chemicals of concern (PCDD/Fs in this case). The quantitative health risk assessment due to a PCDD/F exposure is considered as a combination of five parameters:

- 1 intake of contaminated soil (hand-to-mouth transfer)
- 2 ingestion of vegetables grown in the area under evaluation
- 3 inhalation of re-suspended soil particles
- 4 inhalation of both vapor and particle air concentration
- 5 dermal absorption (Meneses *et al.*, 2004).

In the policies of the EU and its Member States, biomass is expected to play a major role as a renewable energy source (EU, 1997). In the course of implementing this policy, it appeared that a large proportion of the resource base for biomass consists of waste. In the EU, both clean and contaminated biomass types may be used as fuels. However, the stricter emission limit values for waste incineration will be applied to those waste biomass fuels which are not exempted from the waste incineration

legislation. As a consequence, stricter emission limit values will be set for electricity plants which employ contaminated biomass than for electricity plants which are fired with fossil fuels, or clean biomass. In this manner, the use of non-exempted waste biomass for electricity production is either prevented or made more expensive. If prevented, the non-exempted waste biomass is likely to be incinerated in a dedicated waste incineration plant at a low electricity recovery efficiency and the balance of the electricity consumption is probably made up by firing additional coal in an electricity plant, with all associated additional emissions. If its use as a fuel in an electricity plant is not prevented, but does take place, its conversion costs are higher than under a non-waste regime. By substituting fossil fuels, the emission of greenhouse gases will be reduced. But not only those – also SO₂ and dust emissions from the aggregate of power plants and waste incineration plants will be lower, since stricter emission limits apply for these substances if released from fossil fuels or clean biomass. The additional costs therefore for substituting fossil fuels by waste should not be regarded as costs purely made to reduce greenhouse gas emissions, but rather as expenses to achieve other environmental objectives as well. Perhaps an economic consideration may shed some light on the evaluation. At the root of a waste management chain, the value of a waste is always negative since even its handling by the owner requires some cost. However, what is a waste for one may become a valuable material for another to an extent that this value is paid to the primary owner. For example: in some instances sawdust and wood shavings which serve no purpose at a timber factory, when no space heating or wood drying is required, are disposed of at the factory by means of incineration. In other instances they are sold to fuel briquette manufacturers (Siemons, 2002).

A large number of countries are involved in a process of transformation with regard to the management of municipal solid waste. This process is a consequence of environmental requirements that occasionally materialize in legislation, such as the European Council Directive 31/99/EC on waste release in the EU. In some cases, the remediation of old landfills can be carried out in compliance with environmental requirements; in other cases, it is necessary to proceed with the closure of the landfill and to assimilate it into its own environment. A diagnosis tool implies the Environmental Risk Index (ERI) which aims to gage the potential for the environmental impact for each observed parameter, reflecting whether or not interaction exists between the processes in the release point and the characteristics of the environment. Environmental Risk Index depends not only on probability but also on the environmental value of the parameter considered. The aim of this concept is to identify and quantify the environmental aspect of each parameter in the landfill environment, taking as a starting point the relationship between the landfill's environmental and/or social and political characteristics and the emissions in the release point. A representative example is the landfill contamination of surface water and groundwater. The most crucial parameters regarding cross-contamination are the following: landfill compaction, waste and organic matter types, age, cover material, aquifer characteristics, surface drainage system, rainfall, landfill lining system, control of leachate, final cover, fault, release-point location in surface runoff, release-point location in floodwater storage volume and operability (Calvo *et al.*, 2005).

Topics/categories covered under EU legislation

General provisions

The main provisions in the EC Treaty dealing with the protection of the environment and with sustainable development are introduced. After that, some general remarks are made. Then, the different treaties that altered the original European Economic Community (EEC) Treaty into the present European Community (EC) Treaty and the European Union Treaty provisions dealing with the environment and sustainable development are discussed (<http://www.eel.nl/index.asp>). Legislation may be classified as 'horizontal' when it relates to general environmental management issues rather than to specific sectors, products or types of emissions. The three directives in this category concern the collection and assessment of information on the environment and on the wide range of human activities which have impact on the environment. The information may be in the form of an environmental impact assessment of proposed developments, public access to information about the environment, or the requirements and procedures for reporting on the implementation of environmental directives. Accurate information about the environment and the effects of human activities is of the utmost importance since it is the basis for the development, implementation, monitoring and enforcement of environmental protection regulations and policies. It is also the basis for public participation in environmental decision-making and hence for stronger democratic institutions. The Directive on Access to Environmental Information seeks to grant the public access to information on the environment which is held by public authorities or government controlled bodies with public responsibility for the environment. The Environmental Impact Assessment Directive requires that, before governmental approval can be granted, a number of development projects must be subject to a process in which potential environmental effects are assessed. The Directive reporting on implementation of environmental directives harmonizes and seeks to improve upon the Member States' reporting to the Commission (<http://europa.eu.int/comm/environment/guide/part2a.htm>).

Action programs – general provisions

The communication from the Commission to the Council, the European Parliament, the Economic and Social Committee and the Committee of the Regions of 24 January 2001 on the Sixth Environment Action Program of the European Community 'Environment 2010: Our future, our choice' (COM(2001) 31 final – not published in the Official Journal) makes it clear that meeting the challenges of today's environmental problems means looking beyond a strictly legislative approach and taking a strategic approach, using a whole range of instruments and measures to influence decisions made by business, consumers, policy planners and citizens. It proposes five priority avenues of strategic action: ensuring the implementation of existing legislation; integrating environmental concerns into other policies; working closer with the market; empowering people as private citizens and helping them to change behavior; and taking account of the environment in land-use planning and management

decisions. To improve the implementation of legislation, the following specific actions are outlined:

- 1 support for the IMPEL network and its extension to the candidate countries
- 2 reporting on the implementation of environmental law
- 3 a 'name, shame and fame' strategy on the implementation of environmental law
- 4 the improvement of environmental standards of inspection
- 5 initiatives to combat environmental crimes
- 6 pursuing action in the European Court to ensure implementation.

The objective of the Decision No 2179/98/EC (entry into force 10/10/1998) is to transform patterns of growth in the Community in such a way as to promote sustainable development. The program continues to tackle environmental problems (such as climate change, aquatic pollution and waste management), but also aims at establishing new relations among the participants in the environmental sector. The program sets out a new approach to Community environment policy based on the following principles:

- 1 the adoption of a global, proactive approach aimed at the different actors and activities which affect natural resources or pollute the environment
- 2 the will to change current trends and practices which harm the environment for current and future generations
- 3 encouraging changes in social behavior by engaging all the actors concerned (public authorities, citizens, consumers, enterprises, etc.)
- 4 establishing the concept of shared responsibility
- 5 using new environmental instruments.

The Community is limiting its action to the following priority areas:

- 1 long-term management of natural resources: soil, water, countryside and coasts
- 2 an integrated approach to combating pollution and acting to prevent waste
- 3 reducing the consumption of energy from non-renewable sources
- 4 improving the management of mobility by developing efficient and clean modes of transport
- 5 drawing up a coherent package of measures to improve the quality of the urban environment
- 6 improving health and safety, in particular in relation to the management of industrial hazards, nuclear safety and radiation protection.

A summary of the EU Communications and Decisions related to action programs – general provisions is given in Table 4.1.

Principles of the environmental policy – general provisions

The Proposal for a Directive of the European Parliament and of the Council of 23 January 2002 on environmental liability with regard to the prevention and remedying

Table 4.1 EU Communication and Decision (main points and comments) related to action programs – general provisions

Directive	Title	Main points
COM(2001) 31 final Not published in the Official Journal	Communication from the Commission to the Council, the European Parliament, the Economic and Social Committee and the Committee of the Regions of 24 January 2001 on the Sixth Environment Action Program of the European Community 'Environment 2010: Our future, our choice'	<ul style="list-style-type: none"> • Specific actions are outlined to improve the implementation of legislation • Focus on four priority areas for action: climate change, biodiversity, environment and health and sustainable management of resources and wastes • Integration of environmental concerns into all aspects of the European Union's external relations
Decision No 2179/98/EC (entry into force 10/10/ 1998)	The review of the European Community program of policy and action in relation to the environment and sustainable development 'Towards sustainability'	<ul style="list-style-type: none"> • Treaty establishing the European Community explicitly provides for the development and implementation of a Community policy on the environment • To transform patterns of growth in the Community in such a way as to promote sustainable development • Sets out a new approach to Community environment policy based on five principles • Underlines the importance of Community intervention in selected target sectors

Adapted from Arvanitoyannis *et al.*, 2006a

of environmental damage is formulated in COM(2002) 17 final – Official Journal C 151 E of 25/6/2002. The principle, according to which the polluter should pay when environmental damage occurs (the 'polluter pays' principle), is set out in the Treaty establishing the European Community. This principle acts as a deterrent against the violation of environmental standards and thereby contributes to meeting the objectives and implementing EU policy in this area. The aim of the White Paper on environment liability, published in February 2000, was to examine how to implement the 'polluter pays' principle in order to carry out the EU's environmental policy. Under this proposal, environmental damage means damage caused to the aquatic environment covered by Community legislation on water management, species and habitats protected under Community legislation on nature conservation, areas protected under national or regional legislation on nature conservation and health risks resulting from soil contamination. Where there is an imminent threat of environmental damage, the competent authority designated by each Member State will require the operator (the potential polluter) to take the necessary preventive measures, or will take such measures itself and recover the costs incurred at a later date.

Communication from the Commission of 2 February 2000 on the precautionary principle has been recognized in various international agreements, notably in the Sanitary and Phytosanitary Agreement (SPS) concluded in the framework of the World Trade Organization (WTO). A clear definition as to how the Community intends to use the precautionary principle with a view to ensuring an appropriate level of environmental and health protection can contribute to the discussions already launched in

Table 4.2 EU Proposal for a Directive and Communication (main points and comments) focused on principles of the environmental policy – general provisions

Directive	Title	Main points
COM(2002) 17 final Official Journal C 151 E of 25/6/2002	Proposal for a Directive of the European Parliament and of the Council of 23 January 2002 on environmental liability with regard to the prevention and remedying of environmental damage	<ul style="list-style-type: none"> • The polluter should pay when environmental damage occurs (the 'polluter pays' principle) is set out in the Treaty establishing the European Community • Prevention and remedying of environmental damage • Cost recovery • Legal and natural persons likely to be adversely affected by environmental damage may require the competent authority to take action against the damage • Member States report to the Commission on the application of this Directive within five years after its entry into force
Communication from the Commission of 2 February 2000	The precautionary principle	<ul style="list-style-type: none"> • One explicit reference to the precautionary principle • Factors triggering use of the precautionary principle • Measures resulting from precautionary principle • Precautionary principle should be informed by three specific principles • Apart from the rules for drugs, pesticides or food additives, EU legislation does not prescribe a prior authorization system for placing products on the market

Adapted from Arvanitoyannis *et al.*, 2006a

these international arenas. The precautionary principle should be informed by three specific principles:

- 1 implementation of the principle should be based on the fullest possible scientific evaluation. As far as possible this evaluation should determine the degree of scientific uncertainty at each stage
- 2 any decision to act or not to act pursuant to the precautionary principle must be preceded by a risk evaluation and an evaluation of the potential consequences of inaction
- 3 once the results of the scientific evaluation and/or the risk evaluation are available, all the interested parties must be given the opportunity to study of the various options available, while ensuring the greatest possible transparency.

All EU Proposals for a Directive and Communication focused on principles of the environmental policy – general provisions are given in Table 4.2.

Environmental instruments – general provisions

Following the EU Directive 2001/42/EC (entry into force 21/7/2001), the target is to provide a high level of protection of the environment and to contribute to the integration of environmental considerations into the preparation and adoption of plans and programs with a view to promoting sustainable development, by ensuring that an

environmental assessment is carried out of certain plans and programs which are likely to have significant effects on the environment. Member States shall ensure that, when a plan or program is adopted, the authorities referred to in the Directive, the public and any Member State are informed and the following items are made available to those so informed:

- 1 the plan or program as adopted
- 2 a statement summarizing how environmental considerations have been integrated into the plan or program and how the environmental report was prepared, the opinions expressed and the results of consultations entered into pursuant to the Directive have been taken into account and the reasons for choosing the plan or program as adopted, in the light of the other reasonable alternatives dealt with
- 3 the measures decided concerning monitoring.

According to Regulation (EC) No 1210/1990 (entry into force 30/10/1993), the European Environment Agency aims at the setting-up and establishment of a European environment information and observation network. The principal areas of activity of the Agency shall, as far as possible, include all elements enabling it to gather the information making it possible to describe the present and foreseeable state of the environment from the following points of view:

- 1 the quality of the environment
- 2 the pressures on the environment
- 3 the sensitivity of the environment.

The Agency shall furnish information which can be directly used in the implementation of Community environmental policy. Priority will be given to the following areas of work:

- 1 air quality and atmospheric emissions
- 2 water quality, pollutants and water resources
- 3 the state of the soil, the fauna and flora and the biotopes
- 4 land use and natural resources
- 5 waste management
- 6 noise emissions
- 7 chemical substances which are hazardous for the environment
- 8 coastal protection.

In particular, transfrontier, plurinational and global phenomena shall be covered. The socio-economic dimension shall also be taken into account.

In Regulation (EC) No 1655/2000 (entry into force 31/7/2000), the general objective of LIFE shall be to contribute to the implementation, updating and development of Community environment policy and environmental legislation, in particular as regards the integration of the environment into other policies and to sustainable development in the Community. LIFE shall consist of the three thematic components: LIFE-nature,

LIFE-environment and LIFE-third countries. The projects financed by LIFE shall meet the following general criteria:

- 1 be of Community interest by making a significant contribution to the general objective
- 2 be carried out by technically and financially sound participants
- 3 be feasible in terms of technical proposals, timetable, budget and value for money.

The rate of Community financial support shall be a maximum of 30% of the eligible cost of the project for projects generating substantial net revenue. The rate of Community financial support to all other applicants shall be a maximum of 50% of the eligible cost of the project. The rate of Community financial support for the accompanying measures shall be a maximum of 100% of their cost.

Another Regulation, (EC) No 1980/2000 (entry into force 24/9/2000), claimed that the objective of the Community eco-label award scheme (hereafter referred to as the Scheme) was to promote products which had the potential to reduce negative environmental impacts, as compared with the other products in the same product group, thus contributing to the efficient use of resources and a high level of environmental protection. This objective shall be pursued through the provision of guidance and accurate, non-deceptive and scientifically based information to consumers on such products. The environmental impacts shall be identified on the basis of examination of the interactions of products with the environment, including the use of energy and natural resources, during the life cycle of the product. In order to be included in this Scheme, a product group must meet the following conditions:

- 1 it shall represent a significant volume of sales and trade in the internal market
- 2 it shall involve, at one or more stages of the product's life, a significant environmental impact on a global or regional scale and/or of a general nature
- 3 it shall present a significant potential for effecting environmental improvements through consumer choice as well as an incentive to manufacturers or service providers to seek a competitive advantage by offering products which qualify for the eco-label
- 4 a significant part of its sales volume shall be sold for final consumption or use.

According to Regulation (EEC) No 761/2001 (entry into force 27/4/2001), the objective of EMAS was to promote continual improvements in the environmental performance of organizations by:

- 1 the establishment and implementation of environmental management systems by organizations
- 2 the systematic, objective and periodic evaluation of the performance of such systems
- 3 the provision of information on environmental performance and an open dialogue with the public and other interested parties
- 4 the active involvement of employees in the organization and appropriate initial and advanced training that makes active participation in the tasks referred to under (1) possible.

In order for an organization to maintain registration to EMAS it shall:

- 1 have the environmental management system and audit program
- 2 forward the yearly necessary validated updates of its environmental statement to the competent body and make them publicly available.

In the Green Paper of 7 February 2001 on integrated product policy (COM (2001) 68 final – not published in the Official Journal), the proposed strategy called for the involvement of all the parties concerned at all possible levels of action and throughout the life cycle of the products. Eco-design must be promoted by the manufacturers so as to ensure that the products on the market are more environmentally friendly. Distributors should put green products on the shelves and should inform consumers of their existence and benefits. Consumers should preferably choose green products and use them in such a way as to prolong their shelf-life and reduce their impact on the environment. This Green Paper considers the process of educating consumers (including children) and companies as an important way of promoting demand for more environmentally friendly products, thereby working for greener consumption. Public funding of this kind of eco-labeling should be increased, both at European and at national level. The fact that public procurement contracts represent 12% of the European Union's GDP will serve as a potential encouragement to manufacturers to increase the production of green products if such contracts focus on the purchase of environmentally friendly products. With a view to extending eco-design across a broader range of products, steps must be taken to produce and publish information on the environmental impact of products throughout their life cycle. Life Cycle Inventories (LCIs) and Life Cycle Analyses (LCAs) are effective instruments to this end. The Green Paper notes that eco-design guidelines and a general strategy for integrating the environment in the design process could be used as instruments for the promotion of the life cycle concept within companies.

The Communication from the Commission to the European Parliament, the Council, the Economic and Social Committee and the Committee of the Regions of 17 July 2002 on Environmental Agreements at Community Level within the Framework of the Action Plan on the 'Simplification and Improvement of the Regulatory Environment' (COM(2002) 412 final – not published in the Official Journal) was a form of self-regulation as they are not binding at Community level. However, the Commission can encourage them, recognize them (this applies to self-regulation) or propose that the legislature make use of them (this applies to co-regulation). While self-regulation (agreement among social partners) does not involve the adoption of a legislative instrument, the Commission can nevertheless decide to introduce an evaluation system. Environmental agreements should comply with:

- 1 the provisions of the Community Treaties (in particular the rules on competition, the internal market and State aid for the environment) and all international commitments of the Union
- 2 the inter-institutional balance between the Commission, Council and Parliament

- 3 the obligations concerning multilateral trade laid down by the World Trade Organization. The agreements should provide for the participation of operators from third countries
- 4 the provisions of the Aarhus Convention
- 5 national and Community judicial control.

The Report of 23 June 2003 from the Commission to the European Parliament and to the Council referred to the application and effectiveness of the EIA Directive (Directive 85/337/EC as amended by Directive 97/11/EC). The question was 'How successful are the Member States in implementing the EIA Directive?' (COM(2003) 334 final – not published in the Official Journal) revealed that the main problem lies in the way the Directive is applied and not, generally speaking, in the transposition of its legal requirements. To improve the way the Directive was being applied, the Commission invites the Member States to:

- 1 remedy shortcomings in their national and regional legislation on environmental impact assessment
- 2 introduce records to provide annual information on the number and type of projects which have undergone EIA
- 3 make sure that systems with fixed mandatory thresholds (in relation to screening) are so designed as to ensure that all projects that might have significant effects are subject to an appropriate screening process
- 4 make more widespread use of the guidelines on environmental impact assessment and on screening, scoping (i.e. identifying the items on which an environmental impact statement is to focus), review and cumulative impacts
- 5 introduce formal provisions for the review of the environmental information supplied by developers
- 6 organize training for their regional and local authorities to improve their understanding of the EIA Directive
- 7 make more use of the guidance provided by the United Nations Economic Commission for Europe (UN/ECE) in relation to environmental impact assessment.

In order to check the correct implementation of Community law in the Member States, the Commission acts at different stages: first it checks that Member States transpose the Directives in their legal systems within the deadlines set. Then it checks the conformity of the Member States' legislation with the Directives and the application of the latter. To assess the correct application in Member States, the Commission bases its deliberations on reports from Member States on the application of the Directives, any complaints revealing specific situations of potential breach of EC Law; and facts raised through written questions and petitions brought to the Commission's attention by the European Parliament. Approximately 50% of the Member States explicitly state that the guidelines of the Commission are used.

The European environment and health strategy of 11 June 2003 (COM(2003) 338 final – not published in the Official Journal) is to integrate the information on the state of the environment, the ecosystem and human health. The ultimate objective is to

establish a framework towards a better understanding of the cause-and-effect relationships between the environment and health and to make available the information needed to develop an integrated Community policy. The plan is to implement the strategy incrementally in successive cycles. The first cycle, from 2004 to 2010, will focus on the link between environmental factors and:

- 1 childhood respiratory diseases, asthma and allergies
- 2 neurodevelopmental disorders
- 3 childhood cancer
- 4 disruption of the endocrine system (glands which secrete hormones).

In the first cycle, three pilot projects will be launched to develop a method for putting in place a European system for integrated environment and health monitoring. The possibility of developing a harmonized European bio-monitoring system for children will also be considered during the first cycle. Several Member States and some Acceding Countries have set up 'environment and health' bio-monitoring campaigns and related initiatives to explore environmental factors that influence human health.

The Proposal for a Regulation of the European Parliament and of the Council concerning the establishment of a European pollutant release and transfer register (COM(2004) 634 final – not published in the Official Journal) is for a pollutant release and transfer register (PRTR) to be created at European Union (EU) level in the form of a publicly accessible electronic database. This database will meet the requirements of the United Nations Economic Commission for Europe (UN-ECE) Protocol on Pollutant Release and Transfer Registers, signed by the Community in May 2003. The public should be able to access this register free of charge on the Internet and will be able to find information using various search criteria (type of pollutant, geographical location, affected environment, source facility, etc.). The register will contain information on releases of pollutants to air, water and land, as well as transfers of waste and pollutants, where emissions exceed certain threshold values and result from specific activities. The register will also cover releases of pollutants from diffuse sources (such as transport). Information gathered at national level by Member States and reported to the Commission will be fed into the database on a regular basis.

The Decision No 466/2002/EC (entry into force 17/3/2002) makes clear the introduction of a Community action program promoting non-governmental organizations (NGOs) primarily active in the field of environmental protection. The general objective of this program shall be to promote NGOs which are primarily active in the field of environmental protection and enhancement at a European level. Such activities should involve contributing, or being able to contribute, to the development and implementation of Community environmental policy and legislation in different regions of Europe. The program shall be open to the participation of European NGOs established in either:

- 1 the Member States
- 2 the Associated Countries (6) in accordance with the conditions established in the respective Europe Agreements, in the additional protocols thereto and in the decisions of the respective Association Councils

- 3 Cyprus, Malta or Turkey in accordance with conditions and procedures to be agreed with those countries
- 4 the Balkan countries forming part of the Stabilization and Association process for countries of South-Eastern Europe (7) in accordance with conditions and procedures to be agreed with those countries.

The Decision 2004/210/EC (entry into force 3/3/2004) specifies Scientific Committee advisory structure and fields of competence. The following Scientific Committees are hereby established:

- 1 the Scientific Committee on Consumer Products (hereinafter SCCP)
- 2 the Scientific Committee on Health and Environmental Risks (hereinafter SCHER)
- 3 the Scientific Committee on Emerging and Newly Identified Health Risks (hereinafter SCENIHR).

The Commission shall request a scientific opinion from the Scientific Committees in the cases laid down by Community law. The Commission may also request an opinion from the Committees on questions of particular relevance to consumer safety, public health and the environment and not falling within the mandate of other Community bodies. The SCCP and the SCHER shall each consist of a maximum of 19 members. They shall be appointed on the basis of their expertise and, consistent with this, a geographical distribution that reflects the diversity of scientific problems and approaches in the Community. The Commission shall determine the number of members in each committee in accordance with the requisite needs. The SCENIHR shall be composed of 13 members.

The Commission Communication of 26 March 1997, on environmental taxes and charges in the Single Market, includes the broadening of the range of environmental policy instruments as one of its key priorities. On several occasions, the Commission has been invited to explore the potential of new measures, in particular of a fiscal nature. Environmental taxes and charges can be a way of implementing the 'polluter pays' principle by inducing consumers and producers to adopt more environmentally compatible behavior. The Commission defines taxes and charges as covering all compulsory unrequited payments, whether the revenue accrues directly to the Government budget or is destined for particular purposes (e.g. earmarking). The word 'levy' is used to cover taxes and charges. A levy is considered as environmental if the taxable base of the levy has a negative effect on the environment. There are two categories of environmental levies: those charged on pollutant emissions (taxes on water pollution and on noise emissions in the field of aviation) and those charged on products (taxes on pesticides, excise on gasoline . . .). The Commission's strategy is as follows:

- 1 to collect Member States' experiences of environmental taxation
- 2 to analyze the economic and environmental effects of existing levies and
- 3 to monitor the effects of the levies on the Single Market and the competitiveness of European industry.

Following the Commission communication 'Community guidelines on state aid for environmental protection' (Official Journal C 37 of 3/2/2001), the guidelines apply to aid to protect the environment in all sectors governed by the EC Treaty, including those subject to specific Community rules on state aid (steel processing, shipbuilding, motor vehicles, synthetic fibers, transport and fisheries), but excluding state aid for research and development, training aid and the area covered by the guidelines for state aid in the agricultural sector. However, the guidelines do apply to the fisheries and aquaculture sector. The guidelines recognize three main types of environmental aid, namely:

- 1 operating aid to promote waste management and energy saving: firms should normally bear the costs of treating industrial waste in accordance with the 'polluter-pays' principle. All such operating aid is subject to a limited duration of five years where the aid is 'degressive'. Its intensity may amount to 100% of the extra costs in the first year but must have fallen in a linear fashion to zero by the end of the fifth year. For instance, the Commission considers that operating aid may be justified for the combined production of electric power and heat where the costs of producing electric power or heat exceed market prices
- 2 aid for small and medium-sized enterprises (SMEs) for advisory/consultancy services in the environmental field
- 3 investment aid: the investments concerned are investments in land which are strictly necessary in order to meet environmental objectives, investments in buildings, plant and equipment intended to reduce or eliminate pollution and nuisances and investments to adapt production methods with a view to protecting the environment.

The recommendation of the European Parliament and of the Council of 4 April 2001 provided the minimum criteria for environmental inspections in the Member States. By putting forward such criteria regarding the organization, performance, follow-up and publicizing of environmental inspections, this recommendation aims at meeting this requirement. The recommendation covers environmental inspections of all industrial installations, enterprises and facilities subject to authorization, permit or licencing requirements under current Community environmental legislation ('controlled installations'). Inspection entails the following checking that installations comply with Community environmental requirements and monitoring the impact of installations on the environment. These inspections:

- 1 will have to respect a number of minimum criteria (compliance with Community legal requirements, risk analysis based on an integrated approach)
- 2 will have to be mandatory in specific cases (enquiries carried out following environmental complaints, enquiries into accidents, incidents or infringement cases; examinations prior to the granting of authorization for a controlled activity or for the renewal of such authorization)
- 3 will have to be recorded in the form of reports and made available to the public.

The titles, main points and comments of the EU Directive, Regulations, Communication and Decisions dealing with environmental instruments – general provisions are summarized in Table 4.3.

Table 4.3 EU Directive, Regulations, Communication and Decisions (main points and comments) dealing with environmental instruments – general provisions

Directive	Title	Main points	Comments
EU 2001/42/EC (entry into force 21/7/2001)	Assessment of the effects of certain plans and programs on the environment	<ul style="list-style-type: none"> • Directive applied to plans and programs liable to have significant effects on the environment which are prepared and/or adopted by a competent authority or prepared by a competent authority for adoption by means of a legislative procedure • Report must include a non-technical summary of this information • When a plan or program is adopted, the Member State responsible will inform all of the parties concerned which have been consulted 	
Regulation (EC) No 1210/1990 (entry into force 30/10/1993)	Establishment of the European Environment Agency and the European environment information and observation network	<ul style="list-style-type: none"> • Regulation establishing the European Environment Agency (EEA), an independent body whose objective is to protect and improve the environment in accordance with the provisions of the Treaty and Community environment action programs • Agency may cooperate in the exchange of information with other bodies, including the IMPEL network (Implementation and Enforcement of Environmental Law) 	Amendment > Regulation (EC) No 933/1999 (entry into force 5/5/1999) > Regulation (EC) No 1641/2003 (entry into force 1/10/2003) > Additional elements for the articles
Regulation (EC) No 1655/2000 (entry into force 31/7/2000)	Concerning the Financial Instrument for the Environment (LIFE)	<ul style="list-style-type: none"> • LIFE cofinances environmental activities in the Community and in certain non-Community countries • Projects financed by LIFE must meet three general criteria • LIFE consists of three thematic components: LIFE-Nature, LIFE-Environment and LIFE-third countries 	Amendment > Regulation (EC) No 1682/2004 (entry into force 8/10/2004) > Replacement in the Articles Repeal > Regulation (EEC) No 1973/92
Regulation (EC) No 1980/2000 (entry into force 24/9/2000)	A revised Community eco-label award scheme	<ul style="list-style-type: none"> • Eco-label awarded to products available in the Community which meet certain environmental requirements and specific eco-label criteria • Applications for award of an eco-label are subject to payment of a fee • Any product to which the eco-label is awarded is recognizable by the 'daisy' logo • Commission and Member States must promote the use of the eco-label by means of awareness-raising actions and information campaigns 	
Regulation (EEC) No 761/2001 (entry into force 27/4/2001)	Allowing voluntary participation by organizations in a Community eco-management and audit scheme (EMAS)	<ul style="list-style-type: none"> • Objective of the new Community eco-management and audit scheme (EMAS) is to promote improvements in the environmental performance of organizations in all sectors • Competent bodies may suspend or delete an organization or refuse its registration where the latter fails to meet the requirements of this Regulation • Register of environmental verifiers and of organizations registered with EMAS kept by the Commission and made available to the public 	

(Continued)

Table 4.3 (Continued)

Directive	Title	Main points	Comments
COM(2001) 68 final Not published in the Official Journal	Green Paper of 7 February 2001 on integrated product policy	<ul style="list-style-type: none"> ● Regulation commits the Member States to encourage the participation of small and medium-sized undertakings in the eco-management and audit scheme ● All products and services fall within the scope of this Green Paper ● Fixing prices of products ● Green Paper sees the process of educating consumers (including children) and companies as an important way of promoting demand for more environmentally friendly products, thereby making for greener consumption ● Green Paper notes that eco-design guidelines and a general strategy for integrating the environment in the design process could be used as instruments for the promotion of the life cycle concept within companies ● Eco-management and environmental audit schemes, such as the EMAS systems, are important instruments in the quest to ascertain and control the effects of products on the environment 	
COM(2002) 412 final Not published in the Official Journal	Communication from the Commission to the European Parliament, the Council, the Economic and Social Committee and the Committee of the Regions of 17 July 2002 on Environmental Agreements at Community Level within the Framework of the Action Plan on the 'Simplification and Improvement of the Regulatory Environment'	<ul style="list-style-type: none"> ● All environmental agreements covered by the Communication contribute to achieving the objectives of Union policy on the environment ● Environmental agreements are a form of self-regulation as they are not binding at Community level ● Environmental agreements should comply with many provisions ● Procedure for adoption of environmental agreements when they are used as instruments for self-regulation 	
COM(2003) 334 final Not published in the Official Journal	Report of 23 June 2003 from the Commission to the European Parliament and to the Council on the application and effectiveness of the EIA Directive. How successful are the Member States in implementing the EIA Directive?	<ul style="list-style-type: none"> ● Main problem lies in the way the Directive is applied ● Several aspects of the Directive's application need to be improved and strengthened 	
COM(2003) 338 final Not published in the Official Journal	European environment and health strategy of 11 June 2003	<ul style="list-style-type: none"> ● Integrate the information on the state of the environment, the ecosystem and human health ● Implement the strategy incrementally in successive cycles 	

(Continued)

Table 4.3 (Continued)

Directive	Title	Main points	Comments
COM(2004) 634 final Not published in the Official Journal	Proposal for a Regulation of the European Parliament and of the Council concerning the establishment of a European pollutant release and transfer register	<ul style="list-style-type: none"> • Strategy will pave the way for a Community information system for assessing the overall impact of the environment on human health and the cause-and-effect links • Register will contain information on releases of pollutants to air, water and land, as well as transfers of waste and pollutants • How the PRTR will work • Information gathered at national level by Member States and reported to the Commission will be fed into the database on a regular basis • The public will have the opportunity to be involved in further developing the register and preparing amendments 	
Decision No 466/2002/EC (entry into force 17/3/2002)	Laying down a Community action program promoting non-governmental organizations primarily active in the field of environmental protection	<ul style="list-style-type: none"> • To promote activities of NGOs which are primarily active in protecting the environment and contribute to the development and implementation of Community environmental policy in all the regions of Europe • Cover NGOs with five characteristics • Grants to NGOs of member countries will not exceed 70% of the average annual eligible expenses of the organization during the preceding two years • Mechanisms for verification and evaluation of the results of NGOs benefiting under the program have been provided for • Program covered the period from 1 January 2002 to 31 December 2006 and its budget amounts to EUR 32 million 	
Decision 2004/210/EC (entry into force 3/3/2004)	Setting up Scientific Committees in the field of consumer safety, public health and the environment	<ul style="list-style-type: none"> • Decision sets up three advisory Scientific Committees: the Scientific Committee on Consumer Products, the Scientific Committee on Health and Environmental Risks and the Scientific Committee on Emerging and Newly Identified Health Risks • Fields of competence • Members of the three Committees are appointed on the basis of their skills and experience in the field(s) in question and, consistent with this, a geographical distribution that reflects the diversity of scientific problems and approaches in the EU 	Repeals > Decision 97/404/EC > Decision 97/579/EC
Commission Communication of 26 March 1997	Environmental taxes and charges in the Single Market	<ul style="list-style-type: none"> • Provision of a number of economic, technical or fiscal instruments • Environmental taxes and charges can be a way of implementing the 'polluter pays' • Word 'levy' is used to cover taxes and charges • Two categories of environmental levies 	

(Continued)

Table 4.3 (Continued)

Directive	Title	Main points	Comments
Commission communication Official Journal C 37 of 03.02.2001	Community guidelines on state aid for environmental protection	<ul style="list-style-type: none"> • Guidelines apply to aid to protect the environment in all sectors governed by the EC Treaty, including those subject to specific Community rules on state aid but excluding state aid for research and development, training aid and the area covered by the guidelines for state aid in the agricultural sector • Guidelines recognize three main types of environmental aid • Different types of investment aid (aid to help SMEs, energy saving, etc.) 	
Recommendation of the European Parliament and of the Council of 4 April 2001	Providing for minimum criteria for environmental inspections in the Member States	<ul style="list-style-type: none"> • Covers environmental inspections of all industrial installations, enterprises and facilities subject to authorization, permit or licensing requirements under current Community environmental legislation • Lays down a general obligation on Member States • Environmental inspections will require the inspection authorities to regularly carry out inspections in the field 	

Adapted from Arvanitoyannis *et al.*, 2006a

Application and control of Community Environmental Law – General provisions

According to EU Directive 90/313/EC (entry into force 15/6/1990), freedom of access to, and dissemination of, information on the environment held by public authorities should be ensured and set out the basic terms and conditions on which such information should be made available. Member States shall ensure that public authorities are required to make available information relating to the environment to any natural or legal person at his request and without his having to prove an interest. Member States shall define the practical arrangements under which such information is effectively made available. Member States may provide for a request for such information to be refused where it affects:

- 1 the confidentiality of the proceedings of public authorities, international relations and national defense
- 2 public security
- 3 matters which are, or have been, under enquiry (including disciplinary enquiries), or which are the subject of preliminary investigation proceedings
- 4 commercial and industrial confidentiality, including intellectual property
- 5 the confidentiality of personal data and/or files
- 6 material supplied by a third party without that party being under a legal obligation to do so
- 7 material, the disclosure of which would make it more likely that the environment to which such material related would be damaged.

The aim of this Proposal for a Directive of the European Parliament and of the Council on the protection of the environment through criminal law (COM(2001) 139 final – Official Journal C 180 E of 26/6/2001) is to lay down minimum environmental protection standards. The Member States will have to ensure that any act committed intentionally or out of serious negligence, which breaches the Community rules protecting the environment is treated as a criminal offence. An exhaustive list of the relevant Community legislation is attached to the proposal and includes provisions on the following:

- 1 the unauthorized discharge of hydrocarbons, waste oils or sewage sludge into water and the emission of a certain quantity of materials into the air, soil or water
- 2 the treatment, transport, storage and elimination of hazardous waste
- 3 the discharge of waste on or into land or into water, including the improper operation of a landfill site
- 4 the possession and taking of, or trading in protected wild fauna and flora species
- 5 the deterioration of a protected habitat
- 6 trade in ozone-depleting substances.

The Proposal for a Regulation of the European Parliament and of the Council of 24 October 2003 on the application of the provisions of the Århus Convention on Access to Information, Public Participation in Decision-making and Access to Justice in Environmental Matters to EC institutions and bodies (COM(2003) 662 final – not published in the Official Journal) contains the provisions required for applying the Århus Convention to Community institutions and bodies. They:

- 1 guarantee access for the public (one or more natural or legal persons, and associations, organizations or groups of such persons) to environmental information held by Community institutions and bodies
- 2 make environmental information available to the public
- 3 allow public participation in the preparation by the Community of plans and programs relating to the environment
- 4 guarantee public access to justice at Community level in environmental matters.

These databases or registers should include:

- 1 reports on the implementation of Treaties, international Conventions or agreements, Community legislation to the environment
- 2 reports on the state of the environment
- 3 data derived from the monitoring of activities affecting the environment
- 4 authorizations affecting the environment
- 5 environmental impact studies and risk assessments.

Community institutions and bodies must provide for public participation in the preparation of environmental plans and programs.

Following Decision 2003/80/JHA (entry into force 5/2/2003), the Council, concerned by environmental offences, wishes to protect the environment under criminal law, to

step up exchanges of information between Member States and to establish effective cooperation between national authorities. Serious environmental crime is defined as acts which cause, or risk causing pollution of air, water, soil or subsoil and storage or disposal of waste or similar substances. The fact that the act cannot be considered part of the normal, everyday operation of a lawful activity, that the offence is major in scale or that financial gain was obtained or sought are all aggravating circumstances. Anyone convicted of serious environmental crime will be precluded or disqualified from engaging in an activity requiring official authorization where there is a risk that the situation might be abused. Powers and methods of inquiry are available whereby national authorities can investigate and prosecute offences committed:

- 1 on their territory, including on vessels registered in the Member State concerned
- 2 by natural persons who are nationals of or permanently resident in the Member State concerned
- 3 by legal persons based on their territory.

In Decision 2005/370/EC (entry into force 17/5/2005), the UN/ECE Convention on access to information, public participation in decision-making and access to justice in environmental matters, (Århus Convention) was hereby approved on behalf of the Community. The European Community declares that, in accordance with the Treaty establishing the European Community, it is competent for entering into international agreements and for implementing the obligations resulting therefrom, which contribute to the pursuit of the following objectives:

- 1 preserving, protecting and improving the quality of the environment
- 2 protecting human health
- 3 prudent and rational utilization of natural resources
- 4 promoting measures at international level to deal with regional or worldwide environmental problems.

Finally, the Community reiterates its declaration made upon signing the Convention that the Community institutions will apply the Convention within the framework of their existing and future rules on access to documents and other relevant rules of Community law in the field covered by the Convention.

The Commission staff working paper of 27 April 1999, entitled 'First Annual Survey on the implementation and enforcement of Community environmental law' (October 1996 to December 1997), has identified specific new areas for action which might assist in the implementation of environmental law. These are inspections by Member States and access to courts and tribunals. Member States' inspection tasks: there is a wide disparity between Member States' environmental inspection activities. The Commission and the Council therefore envisaged a role for IMPEL in this context. The involvement of IMPEL emphasizes the Commission's intention to involve those with implementation and enforcement responsibilities in the Member States at an early stage of the legislative process. Access to courts and tribunals: the 1992 Rio Declaration on Environment and Development emphasized the importance of access

to information and to justice in matters concerning the environment. It stated that Member States should encourage public awareness by making information widely available and that effective access to justice should be provided.

The Commission working document of 13 July 2000 entitled 'Second Annual Study on the implementation and monitoring of the application of Community environment law' (from January 1998 to December 1999) presented the follow-up measures carried out after the 1996 communication on the implementation of Community environment law:

- 1 the presentation by the Commission on 16 December 1998 of a proposal for a Council Recommendation providing for minimum criteria for environmental inspections. The proposal establishes guidelines for the minimum criteria applicable to environmental inspections of industrial installations and other enterprises and sites of the waste-producing activities.
- 2 A study on the extra-judicial mechanisms for settling disputes and on access to justice, essential elements for effective application of Community environment law: this study has revealed considerable divergences between the Member States with regard to complaints and enquiries and may serve as a basis for future projects in the area.
- 3 Promotion of knowledge of Community environment law: this has been done by means of a program of courses for magistrates and by the launching of a pilot teaching project in European universities, in particular through the creation of 'green chairs'.

In the Commission staff working paper of 1 October 2002, referring to the Third Annual Survey on the implementation and enforcement of Community environmental law (January 2000 to December 2001) (SEC(2002) 1041 – not published in the Official Journal), the report gives the following reasons for this increase:

- 1 the systematic examination by the Commission of the conformity of national implementing measures notified by Member States
- 2 the difficulties faced by Member States in respecting Community law due to their constitutional organization or internal administration
- 3 the broad scope of Community environmental legislation
- 4 absent or inadequate complaint procedures at national level
- 5 the improved public knowledge of Community environmental legislation and public awareness of problems in that field.

Air: several directives in the air sector fell due for transposition in 2001. Reasoned opinions were sent to various Member States due to non-conformity in the air sector. Water: several cases are under way concerning infringements of the Directives on the quality required of surface water intended for the abstraction of drinking water. Nature: infringement proceedings were brought against several Member States in 2001 concerning the birds and habitats Directives. Noise: the Directive on the approximation of laws of the Member States relating to noise emission in the environment by equipment for use outdoors was due to be transposed on 3 July 2001. Chemicals and biotechnology: the Commission brought several court actions against Member States which failed to communicate, within the prescribed period, national measures transposing

directives on chemicals which fell due for transposition in 2001. Waste: infringement proceedings were opened against eleven Member States in the context of the Directive on the landfill of waste, which was to be transposed by 16 July 2001. Environment and industry: the Severo II Directive was due to be transposed by 3 February 1999. Radiation protection: in 2001, infringement procedures were under way against many Member States who had failed to communicate their final transposition measures.

In the Commission staff working paper of 7 June 2003 entitled 'Fourth Annual Survey on the implementation and enforcement of Community environmental law – 2002' (SEC(2003) 804 – not published in the Official Journal) the following topics were covered:

- 1 Freedom of access to information: the Commission dealt with two cases of non-compliance with the freedom of access to information on the environment
- 2 Environmental impact assessment
- 3 Air: infringement procedures were opened for non-notification of national measures implementing various directives on air quality
- 4 Water
- 5 Infringement proceedings continued against a number of Member States for failure to comply with the conservation of wild birds
- 6 Noise: Italy, Greece and the UK were brought before the Court of Justice because of non-notification problems connected with the approximation of the laws of the Member States relating to the noise emission in the environment by equipment for use outdoors
- 7 Chemicals and biotechnology
- 8 Infringement procedures were opened for incorrect application of waste
- 9 Environment and industry: on industry, the Court ruled against Spain, Greece and the UK for failure to adopt the respective laws
- 10 Radiation protection: the Commission took the UK to Court because of non-submission of the Euratom Treaty concerning the dismantling of the JASON research reactor. It also referred Denmark to the Court for failing to give notification of all its undertaken measures.

In the Commission staff working paper of 27 July 2004: 'Fifth annual survey on the implementation and enforcement of Community environmental law 2003' (SEC(2004) 1025 – not published in the Official Journal), in total, the study revealed 88 cases in which the Directives on the environment had not been transposed within the time limit (non-communication), 118 cases in which Directives had been incorrectly transposed (non-conformity) and 95 cases in which Member States had failed to comply with the 'secondary' obligations imposed by the Directives (horizontal bad implementation), for example through failing to comply with the deadlines for presenting certain plans, submitting data or designating protected areas. The areas in which most infringement cases have been opened are air, waste, nature and water.

Some representative points and comments of the EU Directive, Proposals for a Directive, Decisions and Papers regarding application and control of Community Environmental Law – general provisions are given in Table 4.4.

Table 4.4 EU Directive, Proposals for a Directive, Decisions and Papers (main points and comments) for application and control of Community Environmental Law – general provisions

Directive	Title	Main points	Comments
EU 90/313/EC (entry into force 15/6/1990)	The freedom of access to information on the environment	<ul style="list-style-type: none"> • Environmental information is a prerequisite for stepping up the application and monitoring of Community environment law • Disparities can create inequality within the Community as regards access to information and/or as regards conditions of competition • Available information relating to the environment to any natural or legal person at his request and without his having to prove an interest 	<p>Amendment</p> <ul style="list-style-type: none"> > Directive EU 2003/4/EC (entry into force 14/2/2003) • Public access to environmental information
COM(2001) 139 final Official Journal C 180 E of 26/6/2001	Proposal for a Directive of the European Parliament and of the Council on the protection of the environment through criminal law	<ul style="list-style-type: none"> • Minimum environmental protection standards • Any act committed intentionally or out of serious negligence • Criminal penalties must be effective, proportionate and dissuasive 	
COM(2003) 662 final – Not published in the Official Journal	Proposal for a Regulation of the European Parliament and of the Council of 24 October 2003 on the application of the provisions of the Århus Convention on Access to Information, Public Participation in Decision-making and Access to Justice in Environmental Matters to EC institutions and bodies	<ul style="list-style-type: none"> • Provisions necessary to apply the Århus Convention to Community institutions and bodies • Public participation in the preparation of environmental plans and programs • Legal action without having to demonstrate the impairment of a right or a sufficient interest • Regular checks ensure that entities continue to satisfy these conditions 	
Decision 2003/80/JHA (entry into force 5/2/2003)	The protection of the environment through criminal law	<ul style="list-style-type: none"> • Council wishes to protect the environment under criminal law, to step up exchanges of information between Member States • The fact that the act cannot be considered part of the normal, everyday operation of a lawful activity • Powers and methods of inquiry are available whereby national authorities can investigate and prosecute offenses 	
Decision 2005/370/EC (entry into force 17/5/2005)	The conclusion on behalf of the European Community of the Convention on access to information, public participation in the decision-making process and access to justice in environmental matters	<ul style="list-style-type: none"> • Greater public awareness of and involvement in environmental matters will improve environmental protection • Rights and duties regarding access to information, including deadlines for providing information • Public participation in environmental decision-making • Procedural time-frames must allow for genuine public participation 	
Commission staff working paper of 27 April 1999 October 1996 to December 1997	First annual survey on the implementation and enforcement of Community environmental law	<ul style="list-style-type: none"> • Specific new areas for action might assist in the implementation of environmental law • More information on the implementation of environmental law and to improve enforcement • Publishing a White Paper on environmental liability in order to examine and compare different ways of tackling the issue of environmental damage 	

(Continued)

Table 4.4 (Continued)

Directive	Title	Main points	Comments
Commission working document of 13 July 2000 January 1998 to December 1999	Second annual study on the implementation and monitoring of the application of Community environmental law	<ul style="list-style-type: none"> • Commission presents the follow-up measures carried out after the 1996 communication on the implementation of Community environment law • Other specific environmental actions • Application of Community environmental directives depends on correct transposition by the Member States within the set time limits 	
SEC(2002) 1041 Not published in the Official Journal January 2000 to December 2001	Third Annual Survey on the implementation and enforcement of Community environmental law	<ul style="list-style-type: none"> • Report gives five reasons for this increase • Directives about environmental impact assessment, air, water, nature, noise, chemicals and biotechnology, waste, environment and industry, radiation protection • Networks for the application of environmental law • Report looks at how the network is working now, and lists the IMPEL reports and projects adopted in 2000 and 2001 	
SEC(2003) 804 Not published in the Official Journal	Commission staff working paper of 7 June 2003. Fourth annual survey on the implementation and enforcement of Community environmental law – 2002	<ul style="list-style-type: none"> • Freedom of access to information, environmental impact assessment, air, water, nature, noise, chemicals and biotechnology, waste, environment and industry, radiation protection • Implementation and Enforcement of Environmental Law (IMPEL) is an informal network between the environmental authorities in the Member States and the Commission 	
SEC(2004) 1025 Not published in the Official Journal	Commission staff working paper of 27 July 2004: 'Fifth annual survey on the implementation and enforcement of Community environmental law 2003'	<ul style="list-style-type: none"> • Over one third of infringement cases examined by the European Commission in 2003 • 505 new complaints of breaches of environmental legislation, slightly fewer than in 2002 • Areas already opened are air, waste, nature and water • Freedom of access to information, environmental impact assessment, air, water, nature, noise, chemicals and biotechnology, waste, environment and industry, radiation protection 	

Adapted from Arvanitoyannis *et al.*, 2006a

Sustainable development

Sustainable development is about:

- 1 balanced and equitable economic development
- 2 high levels of employment, social cohesion and inclusiveness
- 3 a high level of environmental protection and responsible use of natural resources
- 4 coherent policy making in an open, transparent and accountable political system
- 5 effective international cooperation to promote sustainable development globally.

The concept of sustainable development was first given real political momentum in the United Nations Brundtland Commission report of 1987. The 1992 UN Conference

on Environment and Development in Rio de Janeiro was a ground-breaking meeting, adopting the Rio Declaration on environment and development, as well as the Agenda 21 Action Program. Sustainable development is closely linked to Governance, Better Regulation and Impact Assessment. Indicators to measure progress are also vital. In June 2001, the European Council at Göteborg discussed a strategy for sustainable development proposed by the European Commission. This strategy proposed measures to deal with important threats to our well-being, such as climate change, poverty and emerging health risks, which had been identified in a consultation paper in March 2001. The EU is also committed to promoting sustainable development at the global level. A second paper covering our external policies was adopted by the Commission in February 2002, adding a global dimension to the EU strategy. This was an important Community input to the World Summit on sustainable development in Johannesburg in the autumn of 2002. The UN Commission on sustainable development reviewed progress and promotes implementation of the Johannesburg commitments (http://europa.eu.int/comm/sustainable/index_en.htm).

Sustainable development – general framework

Communication from the Commission of 15 May 2001, ‘A Sustainable Europe for a Better World: A European Union Strategy for Sustainable Development’ (COM(2001) 264 – not published in the Official Journal), stated that the main threats to sustainable development are:

- 1 emissions of greenhouse gases from human activity
- 2 new antibiotic-resistant strains of some diseases
- 3 poverty and social exclusion
- 4 low birth rates
- 5 loss of biodiversity
- 6 transport congestion.

Tackling these unsustainable trends and achieving the vision offered by sustainable development requires: urgent action, committed and far-sighted political leadership, a new approach to policy making, widespread participation and international responsibility. The communication indicates that a review needs to be carried out at each spring European Council to check on progress with the implementation of the strategy.

Communication from the Commission to the European Parliament, the Council, the Economic and Social Committee and the Committee of the Regions ‘Towards a global partnership for sustainable development’ (COM(2002) 82 final – not published in the Official Journal) presents a series of actions to contribute to global sustainable development. They complement the May 2001 strategy for sustainable development and cover economic, social, environmental and financial aspects, as well as coherence of Community policies and governance at all levels. The specific economic activities set out by the Commission are as follows:

- 1 within the framework of the World Trade Organization (WTO), to improve the integration of developing countries into the world economy

- 2 to help developing countries benefit from the global trading system
- 3 to change the generalized system of preferences (GSP) to take account of sustainable development
- 4 to include sustainable development in the bilateral and regional agreements
- 5 to reduce the non-transparent use of the international financial system and to regulate it more efficiently
- 6 to encourage European businesses to be socially responsible
- 7 to promote cooperation between the WTO and international environmental organizations.

The objective of sustainable management of natural and environmental resources is to reverse the trend of the loss of environmental resources by 2015, as well as to develop intermediate objectives in the sectors of water, land and soil, energy and biodiversity.

According to the Communication from the Commission to the Council and the European Parliament of 23 December 2003 'The World Summit on Sustainable Development one year on: implementing our commitments' (COM(2003) 829 final – not published in the Official Journal), the main targets adopted by the international community at the Johannesburg Summit in September 2002 were:

- 1 to reduce the proportion of people without access to safe drinking water and basic sanitation
- 2 to increase access to energy services, energy efficiency and the use of renewable energy
- 3 to reverse the current trend in natural resource degradation
- 4 to reduce biodiversity loss
- 5 to minimize the harmful effects of chemicals
- 6 to promote sustainable patterns of production and consumption
- 7 to promote the implementation of national sustainable development strategies.

The summary of EU Communications related to sustainable development – general framework is given in Table 4.5.

Sustainable development – sustainable development instruments

In the Commission report of 13 March 2002, known as 'environmental technology for sustainable development' (COM(2002) 122 final – not published in the Official Journal), the term 'environmental technology' refers to technologies that prevent pollutants being generated during the production process and discharged at the end, new materials, environmental know-how and new ways of working. In fact, environmental technology refers to all activities which produce goods and services to measure, prevent, limit or correct environmental damage, as well as problems related to waste, noise and ecosystems. It includes three types of activity: pollution management, integrated technologies and products which generate little pollution and resource management. The report reveals the importance of environmental technology on the European and world markets. The EU is particularly competitive in the following sectors: the

Table 4.5 EU Communications (main points and comments) related to sustainable development – general framework

Directive	Title	Main points
COM(2001) 264 Not published in the Official Journal	Communication from the Commission of 15 May 2001 'A Sustainable Europe for a Better World: A European Union Strategy for Sustainable Development' (Commission's proposal to the Gothenburg European Council)	<ul style="list-style-type: none"> • Policy framework to deliver sustainable development • Policies need to be made more consistent and that all of them should give priority to sustainable development • Strategy identifies six unsustainable trends
COM(2002) 82 final Not published in Official Journal	Communication from the Commission to the European Parliament, the Council, the Economic and Social Committee and the Committee of the Regions 'Towards a global partnership for sustainable development'	<ul style="list-style-type: none"> • Series of actions to contribute to global sustainable development • Strategy for sustainable development and covers economic, social, environmental and financial aspects, as well as coherence of Community policies and governance at all levels
COM(2003) 829 final Not published in the Official Journal	Communication from the Commission to the Council and the European Parliament of 23 December 2003 'The World Summit on Sustainable Development one year on: implementing our commitments'	<ul style="list-style-type: none"> • A set of priorities for EU action • EU's 'Water for Life' and 'Energy for Poverty Eradication and Sustainable Development' initiatives, the sustainable management of natural resources, the promotion of sustainable patterns of consumption and production methods, and international environmental governance

Adapted from Arvanitoyannis *et al.*, 2006b

development of water distribution and wastewater treatment infrastructure, waste management, technologies for combating air pollution and renewable energy sources. The report mentions several obstacles to the development of environmental technology: lack of financial resources, risk aversion and uncertainty, lack of information on efficiency, shortage of required skills, economic risks, innovation costs, the segmentation of the market and lack of competition.

The Report from the Commission to the Council of 20 September 2002, Analysis of the 'open list' of environment-related headline indicators (COM(2002) 524 final – not published in the Official Journal) was an analysis of the feasibility and availability of data for the proposed indicators. It was a basis for choosing the seven environmental indicators for eventual inclusion in the 2003 Spring report. The indicators were divided into four groups:

- 1 those feasible in 2002 as the data required are available and reliable
- 2 those feasible only in part in 2002 as the data, although available, are incomplete or not sufficiently up to date
- 3 those unlikely feasible in the near future because, although the data are identifiable, the available sources are inadequate or the data is not always produced on an annual basis
- 4 those for which the available data are not sufficiently clear and for which methodological or other development work will be required.

In order to be able to work out an optimum waste management strategy covering the overall framework and practical implementing measures, the Commission launched the Commission Communication of 27 May 2003 entitled 'Towards a thematic strategy on the prevention and recycling of waste' (COM(2003) 301– Official Journal C 76 of 25 March 2004), which is a process of very broad consultation among all stakeholders on the essential measures and instruments needed to promote waste prevention and recycling. The objective was not to recommend the use of any particular instrument, but to launch a debate on the potential role and efficiency of the different options within the context of an overall thematic strategy. With regard to waste prevention, the Commission has asked and has received contributions on the following:

- 1 exchange of information and experience and dissemination of best practices in national incentive schemes
- 2 ways and means for economic operators to compile and implement waste prevention plans
- 3 the waste prevention potential of the Directive on integrated pollution prevention and control.

Furthermore, in the Commission Communication of 1 October 2003 'Towards a thematic strategy on the sustainable use of natural resources' (COM(2003) 572 – not published in the Official Journal), the Commission sets up the main features of a future thematic strategy with the aim of establishing a framework and adopting measures that will make the sustainable use of natural resources possible without continuing to degrade the environment. In order to ensure that such a strategy is efficient, it should be based on particular elements: the resources themselves, the impact of human activities and actions already initiated. The future thematic strategy should therefore adopt an overall approach, focusing on disseminating information and organizing an action framework with the following main elements:

- 1 gathering knowledge on the links between obtaining and using resources on the one hand and their impact in every phase of their life cycle on the other
- 2 assessing policies impacting on the environment to determine how far policy choices in these different areas are compatible with the aim of decoupling economic growth from environmental degradation, and
- 3 policy integration of the issues relating to natural resources.

Communication from the Commission to the Council and the European Parliament of 28 January 2004 entitled 'Stimulating technologies for sustainable development: an environmental technologies action plan for the European Union' (COM(2004)38 final – not published in the Official Journal) sets an action plan that concerns technologies to manage pollution, less polluting and less resource-intensive products and services and ways to manage resources more efficiently. They reduce costs and improve competitiveness by reducing energy and resource consumption and so creating fewer emissions and less waste. The Commission identifies a number of factors which, in its

opinion, are of importance when promoting environmental technologies and which underpin this action plan:

- 1 environmental technologies are very diverse and can be applied in all economic sectors
- 2 many environmental technologies are under-used
- 3 targeted and effective incentives can contribute to the successful introduction of environmental technologies
- 4 reducing uncertainty about future market developments would boost investment in environmental technologies
- 5 the experience and commitment of the various stakeholders is vital in promoting environmental technologies
- 6 the optimum use of policy and economic instruments (such as legislation, voluntary measures etc.) can accelerate the uptake of environmental technologies
- 7 some of the measures which are needed to promote environmental technologies may not affect investment decisions immediately.

Some major points of the EU legislation focused on sustainable development – sustainable development instruments are presented in Table 4.6.

Sustainable development – integration of environmental policy

The activities to be carried out under Regulation (EC) No 2493/2000 (entry into force 18/11/2000) were as follows:

- 1 global environmental issues, in particular those covered by multilateral environmental agreements, such as climate change, desertification and biological diversity
- 2 transboundary environmental issues, in particular air, soil and water pollution
- 3 environmental impacts related to the integration of developing countries into the world economy
- 4 the inclusion in development cooperation projects of environmental considerations enabling the sustainable dimension of these projects to be distinguished, identified and assessed
- 5 environmental impacts of macroeconomic and sectoral policies in developing countries
- 6 sustainable patterns of production and consumption
- 7 sustainable management and use of natural and environmental resources in all productive sectors such as agriculture, fisheries and industry
- 8 environmental problems caused by the non-sustainable use of resources due to poverty
- 9 sustainable production and use of energy and, in particular, encouragement of the use of renewable energy sources, increased energy efficiency, energy saving and the replacement of especially damaging energy sources by others which are less so
- 10 sustainable production and use of chemical products, in particular hazardous and toxic substances

Table 4.6 EU Communications (main points and comments) with regard to sustainable development – sustainable development instruments

Directive	Title	Main points
COM(2002) 122 final Not published in the Official Journal	Commission report of 13 March 2002, environmental technology for sustainable development	<ul style="list-style-type: none"> • Three types of activity pollution management, integrated technologies and products which generate little pollution and resource management • Environmental technology on the European and world markets • Development of environmental technology are mentioned
COM(2002) 524 final Not published in the Official Journal	Report from the Commission to the Council of 20 September 2002, Analysis of the 'open list' of environment-related headline indicators	<ul style="list-style-type: none"> • Feasibility analysis and availability of data for the proposed indicators • Basis for choosing the seven environmental indicators for eventual inclusion in the 2003 spring report • Concludes by stating that a detailed work program for the production of the indicators will be developed in the next stage
COM(2003) 301 Official Journal C 76 of 25 March 2004	Commission Communication of 27 May 2003 entitled 'Towards a thematic strategy on the prevention and recycling of waste'	<ul style="list-style-type: none"> • Not to recommend the use of any particular instrument but to launch a debate on the potential role and efficiency of the different options within the context of an overall thematic strategy
COM(2003) 572 Not published in the Official Journal	Commission Communication of 1 October 2003: 'Towards a thematic strategy on the sustainable use of natural resources'	<ul style="list-style-type: none"> • Main features of a future thematic strategy with the aim of establishing a framework and adopting measures that will make the sustainable use of natural resources possible without continuing to degrade the environment • Based on particular elements: the resources themselves, the impact of human activities and actions already initiated
COM(2004) 38 final Not published in the Official Journal	Communication from the Commission to the Council and the European Parliament of 28 January 2004 entitled 'Stimulating technologies for sustainable development: an environmental technologies action plan for the European Union'	<ul style="list-style-type: none"> • Action plan concerns technologies to manage pollution, less polluting and less resource-intensive products and services and ways to manage resources more efficiently • Number of factors are of importance when promoting environmental technologies • Three main areas according to their effect

Adapted from Arvanitoyannis *et al.*, 2006b

- 11 conservation of biological diversity – especially by protecting ecosystems and habitats and the conservation of species diversity – the sustainable use of its components, the involvement of holders of traditional knowledge on the use of biological diversity, and the fair and equitable sharing of the benefits arising out of the utilization of genetic resources
- 12 the management of freshwater resources
- 13 coastal zone, estuary and wetland management
- 14 desertification
- 15 urban environment problems relating, inter alia, to transport, waste, wastewater, air pollution and noise, and the quality of drinking water
- 16 environmental problems related to industrial activities.

Communication from the Commission to the European Council of 27 May 1998 on a partnership for integration, entitled 'a strategy for integrating the environment into EU policies (Cardiff – June 1998)' (COM(1998) 333 – not published in the Official Journal), stated that the Commission has set out guidelines which will enable the environmental dimension to be properly integrated into other policies:

- 1 integrating the environment into all activities by Community institutions
- 2 a review of existing policies
- 3 introduction of strategies for action in key areas
- 4 drafting of a Council report for the Vienna European Council on how the environmental dimension has been successfully integrated into other policies of the Member States
- 5 definition of priority actions and mechanisms for monitoring implementation
- 6 review by the European Council of environmental integration into sectoral policies
- 7 a joint study by the Council, Parliament and the Commission on the development of mechanisms for implementing these guidelines and for monitoring their implementation.

Communication from the Commission to the Council, the European Parliament, the Economic and Social Committee and the Committee of the Regions of 27 January 1999, 'Directions towards sustainable agriculture' (COM(1999) 22 final – Official Journal C 173 of 19/6/1999): technological developments and commercial criteria intended to increase yields and reduce costs have greatly increased the intensification of agriculture over the last forty years. The common agricultural policy (CAP) is largely responsible for this intensification. The high level of support for agricultural prices has encouraged intensive agriculture and greater use of fertilizers and pesticides. This has resulted in polluted water and land and the destruction of some important ecosystems. The impact of the intensification of agriculture on the landscape can be included among the other changes in the environment having been speeded up by the prices policy of the CAP. The abandonment of land use for agricultural purposes, mainly for economic reasons, also exerts pressure on the landscape and biodiversity. The Union's environmental strategy under the CAP is based on targeted agri-environmental measures which, particularly in rural areas, go beyond sound agricultural practice and environmental legislation. These measures form an integral part of the rural development programs.

Commission Communication of 28 May 2002 set out a Community Action Plan to integrate environmental protection requirements into the Common Fisheries Policy (CFP) (COM(2002) 186 final) and was part of the reform of the common fisheries policy and proposed specific integration measures. The CFP heavily contributed to environmental objectives without prejudice to its economic and social objectives. It is based on the principles of precaution, prevention, rectification at source and polluter pays, and aims at progressively implementing an ecosystem-based approach, to the extent permitted by scientific knowledge. Integrating environmental protection requirements into the CFP must give priority to reducing the pressure on resources, improving fishing methods and abolishing state aid for the modernization and renewal

of the fishing fleet. To facilitate the integration of environmental protection requirements into the CFP, the European Commission also considered it necessary to:

- 1 stimulate a better understanding of the marine ecosystems in the context of the 6th Framework Program for Community research
- 2 extend management measures to the protection of non-commercial species and habitats
- 3 analyze the application of the principles of prevention, rectification at source and polluter-pays in the field of fisheries
- 4 initiate pilot projects regarding the collection of information on the relationships between fisheries and the environment
- 5 implement integrated coastal zone management
- 6 inform the general public of the impact of fisheries and aquaculture on ecosystems
- 7 consider the use of trade measures compatible with the Community's obligations to promote sustainable and environmentally-sound fishing practices
- 8 study the possibilities offered by eco-labeling
- 9 remedy the harmful effects of human activities.

Communication from the Commission of 11 February 2004 'Towards a thematic strategy on the urban environment' (COM(2004) 60 – Official Journal C 98 of 23/4/2004) focuses on the urban environment, while taking account of related economic and social issues. It will therefore focus on four basic cross-cutting themes: urban management, urban transport, construction and urban design. The main aspect of the strategy in terms of development of sustainable urban management is that each capital city and every other city and town of over 100 000 inhabitants should adopt an environmental management plan for the urban area as a whole, together with targets related to the key environmental impacts and should implement an environmental management system to manage this process and deliver these objectives. Regarding sustainable urban transport, every capital city and every city and town of over 100 000 inhabitants should develop, adopt, implement and regularly revise a sustainable urban transport plan, with short-, medium- and long-term targets.

In the communication from the Commission of 14 October 1998 'Strengthening environmental integration within Community energy policy', the Commission identifies three main objectives of Community energy policy that take account of the environmental dimension:

- 1 to promote energy efficiency/saving
- 2 to increase the share of production and use of cleaner energy sources
- 3 to reduce the environmental impact of the production and use of energy sources.

To achieve these objectives, action in the following areas is proposed:

- 1 facilitating cooperation between the Community, the Member States and relevant parties
- 2 promoting specific energy policy actions

- 3 ensuring better coordination with other Community policy measures in the energy field
- 4 developing the energy policy response to climate change
- 5 developing the external dimension of energy policy
- 6 establishing a monitoring system and identifying indicators for environmental integration.

Communication of 8 June 1999 from the Commission to the European Parliament and the Council regarded the single market and environment. One of the targets set in the action plan for the single market was to deliver a single market for the benefit of all citizens, in which environmental protection would play an important role. The Community must also use economic instruments such as taxes. The Commission proposes a series of measures which could be taken to integrate environmental objectives more fully into various areas of the single market:

- 1 publish a handbook
- 2 assess how proposed environmental measures will contribute to better functioning of the single market
- 3 simplify environmental legislation and administrative procedures
- 4 update the existing Commission database on environmental taxes and charges used in the internal market
- 5 develop the role of environmental agreements
- 6 develop the role and contribution of the Community eco-label award scheme
- 7 review the environment-related national technical regulations
- 8 review the Community framework for State aid for environmental protection
- 9 contribute to the measures taken by the Council on transport and energy, in order to integrate environmental considerations into transport and energy policy.

Communication from the Commission promoting sustainable development in the EU non-energy extractive industry covers the extraction of all solid minerals, except coal and uranium. Lignite, peat, brown coal and oil shale are also excluded from the scope of the communication. From the point of view of the environment, extractive operations raise two types of concern: the use of non-renewable sources may mean that these resources will not be available for future generations and extractive operations harm the environment. Priority issues for the integration of the environment into the extractive industry include prevention of mining accidents, improvement of the overall environmental performance of the industry and sound management of mining waste. The Commission is proposing to draw up an inventory of abandoned mine sites and unrecovered quarries which spoil the landscape and may pose environmental threats.

Communication from the Commission to the Council and the European Parliament entitled 'bringing our needs and responsibilities together – integrating environmental issues and economic policy' shows no inherent contradiction between economic growth and the maintenance of an acceptable level of environmental quality. Therefore, measures to integrate environmental and economic policies should simultaneously reduce pollution and improve the functioning of the economy. The communication

advocates a number of solutions to improve the functioning of environmental product markets: fixing correct prices for environmental goods, creating and assigning well-defined property rights for environmental goods and services which are enforceable by law and tradeable, fixing a price to pay for pollution, establishing deposit-refund schemes to encourage recycling, offering subsidies to goods and services which generate positive environmental effects, negotiating agreements with industry and providing information about the environmental characteristics of goods and services.

Commission Communication of 1 December 1999 to the Council, the European Parliament, the Economic and Social Committee and the Committee of the Regions on air transport and the environment sets out the strategy the EU is to pursue to put in place a coherent and environmentally friendly policy in the field of air transport. The first pillar of the strategy proposed in the communication is the improvement of technical environmental standards on noise and gaseous emissions. It also proposes the introduction of economic and regulatory market incentives to enhance the competitive edge of operators and users who choose to use state-of-the-art technologies and environmentally friendly operations. Another pillar indicated is environmental protection measures to be applied in airports.

Recommendation 2002/413/EC of the European Parliament and of the Council of 30 May 2002 focused on the implementation of Integrated Coastal Zone Management in Europe (Official Journal L 148 of 6/6/2002). The EU recommends that Member States take a strategic approach to their management. This must be based on: protection of the coastal environment, recognition of the threat posed by climate change, the implementation of coastal protection measures, including protection of coastal settlements and their cultural heritage, sustainable economic opportunities and employment options, a functioning social and cultural system, accessible land for recreational purposes and esthetic reasons, the cohesion of remote coastal communities and improved coordination of measures.

A summary of the EU legislation related to sustainable development – integration of environmental policy is given in Table 4.7.

Climate change

Once, all climate changes occurred naturally. However, during the Industrial Revolution, human beings began altering our climate and environment through changing agricultural and industrial practices. Prior to the Industrial Revolution, human activity released very few gases into the atmosphere, but nowadays through population growth, fossil fuel burning and deforestation, the mixture of gases in the atmosphere is heavily affected. Emission inventories are developed for a variety of purposes. Inventories of natural and anthropogenic emissions are used by scientists as inputs to air quality models, by policy makers to develop strategies and policies or track progress of standards, and by facilities and regulatory agencies to establish compliance records with allowable emission rates (<http://yosemite.epa.gov/OAR/globalwarming.nsf/content/emissions.html>). Many chemical compounds found in the Earth's atmosphere act as 'greenhouse gases'. These gases allow sunlight to enter the atmosphere freely.

Table 4.7 EU Regulation and Communications (main points and comments) for sustainable development – integration of environmental policy

Directive	Title	Main points
Regulation (EC) NO 2493/2000 (entry into force 18/11/2000)	Measures to promote the full integration of the environmental dimension in the development process of developing countries	<ul style="list-style-type: none"> • Cooperation projects initiated by various players (governments, public bodies, regional authorities, traditional or local communities, cooperatives, international organizations, non-governmental organizations, private actors) in developing countries and intended to promote sustainable development may receive financial aid and technical assistance from the Community
COM(1998) 333 Not published in the Official Journal	Communication from the Commission to the European Council of 27 May 1998 on a partnership for integration: a strategy for integrating the environment into EU policies (Cardiff, June 1998)	<ul style="list-style-type: none"> • Guidelines will enable the environmental dimension to be properly integrated into other policies
COM(1999) 22 final Official Journal C 173 of 19/6/1999	Communication from the Commission to the Council, the European Parliament, the Economic and Social Committee and the Committee of the Regions of 27 January 1999 – Directions towards sustainable agriculture	<ul style="list-style-type: none"> • Basic environmental rules form an integral part of the support systems for agriculture • Reduction of payments to farmers who do not make the efforts needed to comply with European legislation on the environment • Member States may designate up to 10% of their territory as areas suffering from particular handicaps
COM(2002) 186 final	Commission Communication of 28 May 2002 setting out a Community Action Plan to integrate environmental protection requirements into the Common Fisheries Policy	<ul style="list-style-type: none"> • Integrating environment into common fisheries policy is an obligation laid down in the Treaty • CFP is based on the principles of precaution, prevention, rectification at source and polluter pays
COM(2004) 60 Official Journal C 98 of 23/4/2004	Communication from the Commission of 11 February 2004 'Towards a thematic strategy on the urban environment'	<ul style="list-style-type: none"> • Focus on the urban environment while taking account of related economic and social issues • Focus on four basic cross-cutting themes: urban management, urban transport, construction and urban design
Communication from the Commission of 14 October 1998	Strengthening environmental integration within Community energy policy	<ul style="list-style-type: none"> • Integration of environmental aspects within energy policy should take place in a balanced way and should be based on facts and analysis • Commission identifies three main objectives of Community energy policy that take account of the environmental dimension
Communication of 8 June 1999 from the Commission to the European Parliament and the Council	Single market and environment	<ul style="list-style-type: none"> • To deliver a single market for the benefit of all citizens, in which environmental protection would play an important role • To reinforce the synergies between the single market and environment policies, with the aid of a series of measures on public procurement, standardization and eco-labeling • A series of measures which could be taken to integrate environmental objectives more fully into various areas of the single market
Communication from the Commission	Promoting sustainable development in the EU non-energy extractive industry	<ul style="list-style-type: none"> • The extraction of all solid minerals, except coal and uranium • Lignite, peat, brown coal and oil shale are also excluded from the scope of the communication

(Continued)

Table 4.7 (Continued)

Directive	Title	Main points
Communication from the Commission to the Council and the European Parliament	Bringing our needs and responsibilities together – integrating environmental issues and economic policy	<ul style="list-style-type: none"> • There is no inherent contradiction between economic growth and the maintenance of an acceptable level of environmental quality • Advocates a number of solutions to improve the functioning of environmental product markets
Commission communication of 1 December 1999 to the Council, the European Parliament, the Economic and Social Committee and the Committee of the Regions	Air transport and the environment	<ul style="list-style-type: none"> • Sets out the strategy the EU is to put in place a coherent and environmentally friendly policy in the field of air transport • The improvement of technical environmental standards on noise and gaseous emissions • Environmental protection measures to be applied in airports
Recommendation 2002/413/EC of the European Parliament and of the Council of 30 May 2002 Official Journal L 148 of 6/6/2002	Concerning the implementation of Integrated Coastal Zone Management in Europe	<ul style="list-style-type: none"> • EU recommends that the Member States take a strategic approach to the management of coastal zones

Adapted from Arvanitoyannis *et al.*, 2006b

When sunlight strikes the Earth's surface, a part of it is reflected towards space as infrared radiation (heat). Greenhouse gases absorb this infrared radiation and trap the heat in the atmosphere. Many gases exhibit these 'greenhouse' properties. Some of them occur in nature (water vapor, carbon dioxide, methane and nitrous oxide), while others are exclusively human-made (like gases used for aerosols). There is uncertainty in how the climate system varies naturally and reacts to emissions of greenhouse gases. Making progress in reducing uncertainties in projections of future climate will require better awareness and understanding of the buildup of greenhouse gases in the atmosphere and the behavior of the climate system (<http://www.eia.doe.gov/oiaf/1605/ggcebro/chapter1.html>). During the last century, the Earth's average surface temperature rose by around 0.6°C. Evidence is getting stronger that most of the global warming that has occurred over the last 50 years is attributable to human activities. In its Third Assessment Report, published in 2001, the Intergovernmental Panel on Climate Change (IPCC) projects that global average surface temperatures will rise by a further 1.4 to 5.8°C by the end of this century. This global temperature increase is likely to trigger serious consequences for humanity and other life forms alike, including a rise in sea levels of an estimated 9 to 88 cm by the end of this century, which will endanger coastal areas and small islands, and a greater frequency and severity of extreme weather events. The EU is at the forefront of international efforts to combat climate change and has played a key role in the development of the two major treaties addressing the issue, the United Nations Framework Convention on Climate

Change and its Kyoto Protocol (http://europa.eu.int/comm/environment/climate/home_en.htm).

Climate change legislation

Following the EU Directive 2003/87/EC (entry into force 25/10/2003) ‘allowance’ means an allowance to emit one tonne of carbon dioxide equivalent during a specified period, which shall be valid only for the purposes of meeting the requirements of this Directive and shall be transferable in accordance with the provisions of this Directive and ‘emissions’ means the release of greenhouse gases into the atmosphere from sources in an installation. An application to the competent authority for a greenhouse gas emissions permit shall include a description of:

- 1 the installation and its activities including the technology used
- 2 the raw and auxiliary materials
- 3 the sources of emissions of gases from the installation
- 4 the measures planned to monitor and report emissions in accordance with the guidelines.

Greenhouse gas emissions permits shall contain the following:

- 1 the name and address of the operator
- 2 a description of the activities and emissions from the installation
- 3 monitoring requirements, specifying monitoring methodology and frequency
- 4 reporting requirements
- 5 an obligation to surrender allowances equal to the total emissions of the installation in each calendar year within four months following the end of that year.

Member States may maintain their registries in a consolidated system, together with one or more other Member States. Greenhouse gases referred to carbon dioxide (CO₂), methane (CH₄), nitrous oxide (N₂O), hydrofluorocarbons (HFCs), perfluorocarbons (PFCs) and sulfur hexafluoride (SF₆).

According to the communication on the implementation of the first phase of the European Climate Change Program (COM(2001) 580 – not published in the Official Journal), a package of measures was suggested, which the Commission intended to bring forward during the next 24 months. They were grouped in four sections: cross-cutting, energy, transport and industry. Those measures represented a cost-effective reduction potential of some 122–178 Mt CO₂ eq. However, the ECCP also highlighted the importance of measures which are particularly promising in a long-term perspective and for which the cost-effectiveness constraint of EUR20 per tonne of CO₂ eq. needs to be qualified. In this respect, the emission reduction potential could increase with another 100 Mt of CO₂ eq. in view of reflecting proactive policies in the field of combined heat and power (CHP) and biofuels. This applies particularly to actions in the transport sector.

In the Proposal for a Regulation of the European Parliament and of the Council of 11 August 2003 on certain fluorinated greenhouse gases (COM(2003) 492 – not

published in the Official Journal), it was stated the proposed Regulation aimed at reducing emissions of certain fluorinated gases (HFCs, PFCs and sulfur hexafluorides), to improve containment and monitoring of these gases and restrict their marketing and use. The proposal would lead to a reduction in emissions of 23 million tonnes of carbon dioxide equivalent by 2010, and an even greater reduction thereafter. HFCs are used as refrigerants, cleaning solvents and foam blowing agents. PFCs are used in semi-conductor manufacture, as cleaning solvents and as foam blowing agents. Sulfur hexafluorides are used in high-voltage switch gear and magnesium production. Emissions of these three gases are forecast to increase to around 98 million tonnes of carbon dioxide equivalent by 2010, representing 2–4% of total projected greenhouse gas emissions for the period. In order to improve the confinement of fluorinated greenhouse gases, the proposal states that:

- 1 all persons responsible for emissions are required to take all measures to prevent and minimize leakages
- 2 refrigeration, air-conditioning and heat-pump equipment and fire protection systems must undergo at least one leakage inspection a year
- 3 the owners of refrigeration, air-conditioning and heat-pump equipment and fire protection systems containing 300 kg or more of fluorinated gas are required to install leak detection systems
- 4 the owners of refrigeration, air-conditioning and heat-pump equipment and fire protection systems containing 3 kg or more of fluorinated gas are required to maintain records, these records must indicate the quantity and type of gas.

The use of sulfur hexafluoride was prohibited from 1 January 2007, except for magnesium die-casting where the annual consumption of sulfur hexafluoride is below 500 kg.

The Decision 2002/358/EC (entry into force 15/5/2002) made clear that the Commission shall, at the latest by 31 December 2006, determine the respective emission levels allocated to the European Community and to each Member State in terms of tonnes of carbon dioxide equivalent following the establishment of definitive base-year emission figures and on the basis of the quantified emission limitation or reduction commitments taking into account the methodologies for estimating anthropogenic emissions by sources and removals by sinks referred to in the Protocol and the modalities for the calculation of assigned amount pursuant to the Protocol. The Kyoto Protocol tackles emissions of six greenhouse gases: carbon dioxide (CO₂), methane (CH₄), nitrous oxide (N₂O), hydrofluorocarbons (HFC), perfluorocarbons (PFC) and sulfur hexafluoride (SF₆). It represents an important step forward in the effort to tackle global warming, as it includes binding, quantified objectives for limiting and reducing greenhouse gases. Overall, the Parties of the Framework Convention undertake to reduce their greenhouse gas emissions by at least 5% below 1990 levels during the period 2008 to 2012. The EU Member States collectively must reduce their greenhouse gas emissions by 8% between 2008 and 2012. For the period up to 2008, the Parties undertake to make demonstrable progress in achieving their commitments by no later than 2005.

Furthermore, another Decision 280/2004/EC (entry into force 10/3/2004) claims that it establishes a mechanism for:

- 1 monitoring all anthropogenic emissions by sources and removals by sinks of greenhouse gases not controlled by the Montreal Protocol on substances that deplete the ozone layer in the Member States
- 2 evaluating progress towards meeting commitments in respect of these emissions by sources and removals by sinks
- 3 implementing the UNFCCC and the Kyoto Protocol, greenhouse gas inventories, national systems and registries of the Community and its Member States, and the relevant procedures under the Kyoto Protocol
- 4 ensuring the timeliness, completeness, accuracy, consistency, comparability and transparency of reporting by the Community and its Member States to the UNFCCC Secretariat.

Member States shall, for the assessment of actual progress and to enable the preparation of annual reports by the Community, in accordance with obligations under the UNFCCC and the Kyoto Protocol, determine and report to the Commission by 15 January each year (year X):

- 1 their anthropogenic emissions of greenhouse gases listed in the Kyoto Protocol (carbon dioxide (CO₂), methane (CH₄), nitrous oxide (N₂O), hydrofluorocarbons (HFCs), perfluorocarbons (PFCs) and sulfur hexafluoride (SF₆)) during the year before last (year X-2)
- 2 provisional data on their emissions of carbon monoxide (CO), sulfur dioxide (SO₂), nitrogen oxides (NO_x) and volatile organic compounds (VOC) during the year before last (year X-2), together with final data for the year three-years previous (year X-3)
- 3 their anthropogenic greenhouse gas emissions by sources and removals of carbon dioxide by sinks resulting from land-use, land-use change and forestry during the year before last (year X-2)
- 4 information with regard to the accounting of emissions and removals from land-use, land-use change and forestry where a Member State decides to make use of it and the relevant decisions thereunder, for the years between 1990 and the year before last (year X-2)
- 5 any changes to the information relating to the years between 1990 and the year three-years previous (year X-3)
- 6 the elements of the national inventory report necessary for the preparation of the Community greenhouse gas inventory report, such as information on the Member State's quality assurance/quality control plan, a general uncertainty evaluation, a general assessment of completeness and information on recalculations performed
- 7 information from the national registry, once established, on the issue, acquisition, holding, transfer, cancellation, withdrawal and carry over of assigned amount units, removal units, emission reduction units and certified emission reductions during the previous year (year X-1)

- 8 information on legal entities authorized to participate in mechanisms under the Kyoto Protocol, in compliance with relevant national or Community provisions
- 9 steps taken to improve estimates, for example where areas of the inventory have been subject to adjustments
- 10 information on indicators for the year before last (year X–2)
- 11 any changes to the national inventory system.

According to the Green Paper on greenhouse gas emissions ‘towards a European Climate Change Program (ECCP)’, emissions trading is a scheme whereby companies are allocated allowances for their greenhouse gas emissions according to the overall environmental ambitions of their government. It is a very practical system in that individual companies are able to emit more than their allowance on condition that they can find another company which has emitted less than allowed and is willing to sell its ‘spare’ allowances. Community-wide emissions trading could reduce the cost of implementing the Community’s Kyoto commitments by nearly a fifth. Moreover, a Community emissions trading scheme would lead to one single price for allowances traded by companies, which would be compatible with the smooth functioning of the internal market. The degree of Community intervention depends on the nature of the system. The Community could opt for a supervising role (low-level intervention) or the role of a regulating authority (harmonization – firm intervention). Whatever it chooses, it will be necessary to:

- 1 ensure equal treatment for companies of comparable size under the emissions trading scheme
- 2 minimize the possibility of competition being distorted
- 3 ensure synergy with existing legislation
- 4 ensure the scheme is applied effectively
- 5 ensure compatibility with the scheme established by the Kyoto Protocol.

Some representative points and comments (amendments, repeals) of the EU Directive, Communications, Decisions and Green Paper about climate change are given in Table 4.8.

Waste management

In the EU, more than 1.3 billion tonnes of waste are produced annually. Most of the waste is either burnt in incinerators or dumped into landfill sites (67%). However, both these methods create environmental damage. The EU’s Sixth Environment Action Program primary objective is to decouple waste generation from economic activity. The EU’s approach to waste management is based on three principles:

- 1 waste prevention by improving product design
- 2 recycling and re-use including packaging waste, end-of-life vehicles, batteries, electrical and electronic waste
- 3 improving final disposal and monitoring.

Table 4.8 EU Directive, Communications, Decisions and Green Paper (main points and comments) dealing with climate change

Directive	Title	Main points	Comments
EU 2003/87/EC (entry into force 25/10/2003)	Establishing a scheme for greenhouse gas emission allowance trading within the Community	<ul style="list-style-type: none"> • The operator of the installation is capable of monitoring and reporting the emissions • At least 95% of the allowances for the initial three-year period are allocated to the installations free of charge • The operator must submit a report to the competent authority detailing the greenhouse gas emissions 	<p>Amendment</p> <ul style="list-style-type: none"> > Directive EU 2003/87/EC (entry into force 13/11/2004) • Replacement, correction and amendment of articles
COM(2001) 580 Not published in the Official Journal	Communication on the implementation of the first phase of the European Climate Change Program	<ul style="list-style-type: none"> • A package of instruments which also includes a proposal for a decision on the ratification of the Kyoto Protocol and a proposal for a Directive on emissions trading within the EU • There are four types of measure: cross-cutting, energy, transport and industry 	
COM(2003) 492 Not published in the Official Journal	Proposal for a Regulation of the European Parliament and of the Council of 11 August 2003 on certain fluorinated greenhouse gases	<ul style="list-style-type: none"> • Reduction of emissions of certain fluorinated gases, to improve containment and monitoring of these gases • Confinement of fluorinated gases • Air conditioning systems in new vehicles 	
Decision 2002/358/EC (entry into force 15/5/2002)	Approval, on behalf of the European Community, of the Kyoto Protocol to the United Nations Framework Convention on Climate Change and the joint fulfilment of commitments thereunder	<ul style="list-style-type: none"> • Framework Convention may be considered a success • Member States were to coordinate their action to deposit their tools of ratification • Kyoto Protocol tackles emissions of six greenhouse gases • Represents an important step forward in the effort to tackle global warming 	
Decision 280/2004/EC (entry into force 10/3/2004)	Mechanism for monitoring Community greenhouse gas emissions and for implementing the Kyoto Protocol	<ul style="list-style-type: none"> • Decision establishes a mechanism designed to monitor in the Member States all anthropogenic greenhouse gas emissions • Registries accounting for the issue, holding, transfer, cancellation and withdrawal of units 	
Green Paper	On greenhouse gas emissions: towards a European Climate Change Program (ECCP)	<ul style="list-style-type: none"> • Emissions trading is a scheme whereby companies are allocated allowances for their greenhouse gas emissions • Companies taking part in the emissions trading scheme will be regulated either by their national authorities or by the Commission • Scope of an emissions trading scheme: initial allocation of emission allowances, synergy with other policies and measures, compliance and enforcement 	

Adapted from Arvanitoyannis *et al.*, 2006b

To this end, the EU has recently approved a Directive setting strict guidelines for land-fill management and another recent Directive that lays down tough limits on emission levels from incinerators. The Union also aims at reducing emissions of dioxins and acid gases such as NO_x, sulfur dioxide (SO₂) and HCL (<http://europa.eu.int/comm/environment/waste/>). More specifically, solid waste disposal is becoming more difficult with each passing year. Although the generation of solid waste cannot be eliminated, there is ample opportunity to reduce significantly the amount of waste created. The second best option is to recycle unwanted materials rather than disposing of them. The next option is to use the waste materials for energy recovery by use of a solid waste incinerator that produces usable energy. Landfilling is the least desirable option for solid waste disposal, yet our current disposal practices rely heavily on landfilling. Another serious matter is the control of hazardous wastes, no longer of value to their owner or producer and which represent a threat to human health or the environment. Most hazardous wastes are an unfortunate by-product of 20th century industrial and technological innovations, exemplified by the chemical and petrochemical industries and a wide spectrum of new manufacturing procedures (Ray, 1995). The Community's approach has been to assign more responsibility to the producer. At international level, this approach was also adopted at the first Conference of the Parties to the OSPAR Convention for the Protection of the Marine Environment of the North-East Atlantic. The EU has defined the waste flows to be given priority consideration. As a consequence, it has adopted legislation on packaging waste (EU Directive 94/62/EC), batteries (EU Directive 91/157/EEC) and mineral oils (EU Directive 75/439/EEC). The various options for treating waste, such as disposal in landfills (EU Directive 1999/31/EC) and incineration, have also been the subject of Community measures (<http://europa.eu.int/scadplus/leg/en/lvb/l28066.htm>).

Waste management – general framework

From the scope of EU Directive 75/442/EEC (entry into force 18/7/1977), the wastes excluded are:

- 1 radioactive waste
- 2 waste resulting from prospecting, extraction, treatment and storage of mineral resources and the working of quarries
- 3 animal carcasses
- 4 wastewaters
- 5 gaseous effluents emitted into the atmosphere
- 6 waste covered by specific Community rules.

Member States shall take appropriate steps to encourage the prevention, recycling and processing of waste, the extraction of raw materials and possibly of energy therefrom and any other process for the re-use of waste. They shall inform the Commission of any draft rules to such effect and, in particular, of any draft rule concerning:

- 1 the use of products which might be a source of technical difficulties as regards disposal or lead to excessive disposal costs

- 2 the encouragement of the reduction in the quantities of certain waste, the treatment of waste for its recycling and re-use, the recovery of raw materials and/or the production of energy from certain waste
- 3 the use of certain natural resources, including energy resources, in applications where they may be replaced by recovered materials.

The purpose of EU Directive 96/61/EC (entry into force 30/10/1996) was to achieve integrated prevention and control of pollution arising from the activities listed. It laid down measures designed to prevent or, where that is not practicable, to reduce emissions in the air, water and land from activities, including measures concerning waste, in order to achieve a high level of protection of the environment taken as a whole. Member States shall take the necessary measures to provide that the competent authorities ensure that installations are operated in such a way that:

- 1 all the appropriate preventive measures are taken against pollution
- 2 no significant pollution is caused
- 3 waste production is avoided
- 4 energy is used efficiently
- 5 the necessary measures are taken to prevent accidents and limit their consequences
- 6 the necessary measures are taken upon definitive cessation of activities to avoid any pollution risk and return the site of operation to a satisfactory state.

Member States shall take the necessary measures to ensure that no new installation is operated without a permit. They shall take the necessary measures to ensure that an application to the competent authority for a permit includes a description of:

- 1 the installation and its activities
- 2 the raw and auxiliary materials, other substances and the energy used in or generated by the installation
- 3 the sources of emissions from the installation
- 4 the conditions of the site of the installation
- 5 the nature and quantities of foreseeable emissions from the installation
- 6 the proposed technology and other techniques for preventing or, where this not possible, reducing emissions from the installation
- 7 where necessary, measures for the prevention and recovery of waste generated by the installation
- 8 further measures planned to comply with the general principles of the basic obligations of the operator.

The aim of EU Directive 1999/31/EC (entry into force 16/7/1999) was to provide measures, procedures and guidance to prevent or reduce as far as possible negative effects on the environment, in particular the pollution of surface water, groundwater, soil and air, and on the global environment, including the greenhouse effect, as well as any resulting risk to human health, from landfilling of waste, during the whole

life cycle of the landfill. The following shall be excluded from the scope of this Directive:

- 1 the spreading of sludges and similar matter on the soil for the purposes of fertilization or improvement
- 2 the use of inert waste which is suitable, in redevelopment/restoration and filling-in work, or for construction purposes, in landfills
- 3 the deposit of non-hazardous dredging sludges alongside small waterways.

Each landfill should be classified into one of the following classes:

- 1 landfill for hazardous waste
- 2 landfill for non-hazardous waste
- 3 landfill for inert waste.

Regulation (EC) No 259/93 (entry into force 9/2/1993) was applied to shipments of waste within, into and out of the Community. The following was excluded from the scope of this Regulation:

- 1 the offloading to shore of waste generated by the normal operation of ships and off-shore platforms, including wastewater and residues, provided that such waste is the subject of a specific binding international instrument
- 2 shipments of civil aviation waste
- 3 shipments of radioactive waste
- 4 shipments of waste
- 5 shipments of waste into the Community.

Where the notifier intends to ship waste for disposal from one Member State to another Member State and/or pass it in transit through one or several other Member States, he shall notify the competent authority of destination and send a copy of the notification to the competent authorities of dispatch and of transit and to the consignee. Member States shall, however, establish an appropriate system for the supervision and control of shipments of waste within their jurisdiction. All exports of waste for disposal shall be prohibited, except those to EFTA countries which are also parties to the Basle Convention. All exports of waste for recovery were prohibited except those to countries to which the OECD decision applies and other countries which are Parties to the Basle Convention or with which individual Member States have concluded bilateral agreements and arrangements prior to the date of application of this Regulation.

The purpose of Regulation (EC) No 2150/2002 (entry into force 9/2/2003) was to establish a framework for the production of Community statistics on the generation, recovery and disposal of waste. The statistics shall cover:

- 1 generation of waste
- 2 recovery and disposal of waste
- 3 import and export of waste for which no data are collected.

Member States shall acquire the data necessary for the specification of the characteristics by means either of: surveys, administrative or other sources, statistical estimation procedures on the basis of samples or waste-related estimators or a combination of these means. They shall transmit the results, including confidential data, to Eurostat in an appropriate format and within a set period of time from the end of the respective reference periods. The Commission shall draw up a program for pilot studies on waste from specific economic activities.

According to the Communication from the Commission of 22 July 1998, entitled 'the competitiveness of the recycling industries', the recycling industries are confronted with insufficient demand, precarious market structures which are not very competitive and excessive competition from 'virgin' raw materials (non-recycled). Despite the disparity among the different branches of recycling, it is possible to identify a number of factors of competitiveness which are common to all branches. These concern production, the supply and demand for recycled products and the ways in which the markets operate. The factors operating at the production and supply level identified by the Commission are:

- 1 structural aspects, notably the increase in the cost of recycled products
- 2 technical aspects affecting the cost of collecting and sorting.

Finally, the Commission identified the following factors affecting the functioning of the markets and the business framework:

- 1 a lack of transparency, revealed by the almost total absence of indicators and statistics, and market fragmentation
- 2 a lack of consistency in the way in which existing Community regulations are applied.

Among actions in the area of standardization, the Commission proposes:

- 1 the review of industrial standards to ensure that design favors the aptitude of products for recycling and to eliminate obstacles to the use of secondary raw materials
- 2 the substitution of hazardous substances by other substances in products
- 3 the harmonization of specifications and testing methods for recycled products and the development of marking systems aimed at facilitating the identification of substances and at aiding consumers to separate types of waste.

The report from the Commission to the Council and the European Parliament of 19 May 2003 on the implementation of Community waste legislation, in particular Directive 75/442/EEC on waste, Directive 91/689/EEC on hazardous waste, Directive 75/439/EEC on waste oils, Directive 86/278/EEC on sewage sludge and Directive 94/62/EC on packaging and packaging waste, for the period 1998–2000 (COM (2003) 250 final – not published in the Official Journal), highlighted an increase in domestic waste per inhabitant and that the production of hazardous waste has stabilized. However, most Member States have notified the Commission, in accordance with

Directive 91/689/EEC, of the waste which, in their opinion, is of a hazardous nature. The hierarchy of principles established by Directive 75/442/EEC was as follows: prevention, recycling, energy recovery and safe disposal. The provisions of Directive 86/278/EEC proved very effective in fighting pollution arising from the use of sewage sludge. The quality of data concerning waste should improve with the implementation of Regulation (EC) No 2150/2002/EC on waste statistics. Most Member States comply with Directives 75/442/EEC and 91/689/EEC which require operators of waste management installations and producers of hazardous waste to keep registers. However, some countries do not comply with Directive 86/278/EEC which lays down similar provisions on sewage sludge.

The Commission launched a process of very broad consultation among all stakeholders on the essential measures and instruments needed to promote waste prevention and recycling. The objective of the Commission Communication of 27 May 2003, entitled 'Towards a thematic strategy on the prevention and recycling of waste (COM(2003) 301 final – Official Journal C 76 of 25 March 2004), was not to recommend the use of any particular instrument but to launch a debate on the potential role and efficiency of the different options within the context of an overall thematic strategy. With regard to waste prevention, the Commission has asked and has received contributions on the following:

- 1 exchange of information and experience and dissemination of best practices in national incentive schemes
- 2 the role which the future chemicals policy could play in reducing the hazardousness of chemical waste
- 3 ways and means for economic operators to compile and implement waste prevention plans
- 4 the waste prevention potential of the Directive on integrated pollution prevention and control.

With regard to waste recycling, the Commission asked for and obtained comments on:

- 1 fixing more efficient recycling targets
- 2 the use of economic market-based instruments to control recycling costs, such as coordinated landfill taxes
- 3 the possibility of making producers responsible for recycling
- 4 measures enabling the adoption of homogeneous rules on recycling.

The titles, main points and comments of the EU Directives, Regulation and Communications (main points and comments) for waste management – general framework are summarized in Table 4.9.

Waste management – specific waste

EU Directive 75/439/EEC (entry into force 18/6/1977) says that Member States shall take the necessary measures to ensure the safe collection and disposal of waste oils

Table 4.9 EU Directives, Regulation and Communications (main points and comments) focused on waste management – general framework

Directive	Title	Main points	Comments
EU 75/442/EEC (entry into force 18/7/1977)	Waste	<ul style="list-style-type: none"> • Application for all substances or objects • No application for radioactive waste, mineral waste, animal carcasses and agricultural waste, wastewater and gaseous • All holders of wastes shall hand wastes over to a private or public collection agency or to a disposal company • Companies or establishments treating, storing or dumping waste for another party must obtain an authorization from the competent authority • Competent authorities shall draw up one management plan governing the types, quantities and origins of the wastes etc. 	Amendments > Directive EU 91/156/EEC (entry into force 1/4/1993) > Directive EU 91/692/EEC (entry into force 1/1/1995) > Directive EU 96/350/EC (entry into force 28/5/1996) > Directive EU 96/59/EC (entry into force 16/9/1996) <ul style="list-style-type: none"> • Additional elements for the articles
EU 96/61/EC (entry into force 30/10/1996)	Integrated pollution prevention and control	<ul style="list-style-type: none"> • Procedure for applying for operating permits and minimum requirements to be included in any such permit is laid down • Member States inspect industrial installations and ensure they comply with the provisions 	
EU 1999/31/EC (entry into force 16/7/1999)	The landfill of waste	<ul style="list-style-type: none"> • Definition of the different categories of waste and application for all landfills • No application for the spreading on the soil of sludges, the use in landfills of inert waste for redevelopment or restoration work, the deposit of unpolluted soil or of non-hazardous inert waste resulting from prospecting and extraction, treatment and storage of mineral resources 	Amendment > Regulation (EC) No 1882/2003 (entry into force 20/11/2003) <ul style="list-style-type: none"> • Replacement of annexes
Regulation (EC) No 259/93 (entry into force 9/2/1993)	The supervision and control of shipments of waste within, into and out of the European Community	<ul style="list-style-type: none"> • Shipments of waste, both within and into or out of the European Community, to waste transported between Member States but routed through one or more third countries, and to waste transported between third countries but routed through one or more Member States • Concerns the application by the Member States of a system of prior authorization for the shipment of waste • Distinction between waste for disposal and waste for recovery • A standard consignment note for shipments of waste • Member States must take the necessary steps to inspect, sample and monitor waste shipments 	Amendments > Decision 94/721/EC (entry into force 24/10/1994) > Decision 96/660/EC (entry into force 18/11/1996) > Regulation No 120/97 (entry into force 27/1/1997) > Regulation No 2408/98 (entry into force 25/11/1999) > Decision 1999/816/EC (entry into force 25/11/1999) > Regulation No 1420/1999 (entry into force 30/9/1999) > Regulation No 1547/1999 (entry into force 16/8/1999)

(Continued)

Table 4.9 (Continued)

Directive	Title	Main points	Comments
Regulation (EC) No 2150/2002 (entry into force 29/12/2002)	Waste statistics	<ul style="list-style-type: none"> ● Member States and the Commission produce statistics on waste production, recovery and disposal of waste and import and export of waste ● Statistics are to be produced using the statistical nomenclature set out ● Data are to be collected by means of surveys, statistical estimation procedures or referral to administrative or other sources 	<ul style="list-style-type: none"> > Regulation No 2557/2001 (entry into force 1/1/2001) ● Replacement of annexes <p>Amendment</p> <ul style="list-style-type: none"> > Regulation (EC) No 574/2004 (entry into force 16/4/2004) ● Amendment of annexes
Communication from the Commission of 22 July 1998	The competitiveness of the recycling industries	<ul style="list-style-type: none"> ● Constitutes a partial response to the Council's invitation, formulated in its Resolution of 24/2/1997, on a Community strategy for waste management ● Commission advocates the following regulatory measures: (a) increased transparency, (b) simplification of Community legislation, (c) increased use of market-based and regulatory instruments and (d) the drawing up of new measures 	
COM(2003) 250 final Not published in the Official Journal	Report from the Commission to the Council and the European Parliament of 19 May 2003 on the implementation of Community waste legislation, in particular Directive 75/442/EEC on waste, Directive 91/689/EEC on hazardous waste, Directive 75/439/EEC on waste oils, Directive 86/278/EEC on sewage sludge and Directive 94/62/EC on packaging and packaging waste, for the period 1998–2000	<ul style="list-style-type: none"> ● Report stresses that it is not yet satisfactory ● Hierarchy of principles established by Directive EU 75/442/EEC is as follows: prevention, recycling, energy recovery and safe disposal ● Quality of data concerning waste should improve with the implementation of Regulation (EC) No 2150/2002 on waste statistics ● Most Member States comply with Directives EU 75/442/EEC and EU 91/689/EEC which require operators of waste management installations and producers of hazardous waste to keep registers. However, some countries do not comply with Directive EU 86/278/EEC which lays down similar provisions on sewage sludge 	
COM(2003) 301 final Official Journal C 76 of 25 March 2004	Commission Communication of 27 May 2003 entitled 'Towards a thematic strategy on the prevention and recycling of waste'	<ul style="list-style-type: none"> ● Establishing an overall coherent policy on preventing and recycling waste ● A process of very broad consultation among all stakeholders on the essential measures and instruments needed to promote waste prevention and recycling 	

Adapted from Arvanitoyannis *et al.*, 2006c

and shall take the necessary measures to ensure that, as far as possible, the disposal of waste oils is carried out by recycling. They shall also take the necessary measures to ensure the prohibition of:

- 1 any discharge of waste oils into internal surface waters, groundwater, coastal waters and drainage systems
- 2 any deposit and/or discharge of waste oils harmful to the soil and any uncontrolled discharge of residues resulting from the processing of waste oils
- 3 any processing of waste oils causing air pollution which exceeds the level prescribed by existing provisions.

The main aim of EU Directive 78/176/EEC (entry into force 21/2/1979) was the prevention and progressive reduction, with a view to its elimination, of pollution caused by waste from the titanium dioxide industry. Member States should take the necessary measures to ensure that waste is disposed of without endangering human health and without harming the environment and, in particular:

- 1 without risk to water, air, soil and plants and animals
- 2 without deleteriously affecting beauty-spots or the countryside.

They should take appropriate measures to encourage the prevention, recycling and processing of waste, the extraction of raw materials and any other process for the re-use of waste. The discharge, dumping, storage, tipping and injection of waste are prohibited unless prior authorization is issued by the competent authority of the Member State in whose territory the waste is produced.

EU Directive 82/883/EEC (entry into force 9/12/1984) laid down the procedures for the surveillance and monitoring of the effects on the environment, with regard to its physical, chemical, biological and ecological aspects, of the discharge, dumping, storage on, tipping on or injection into the ground of waste from the titanium dioxide industry. Member States should carry out surveillance and monitoring of the environments affected and of a neighboring zone deemed to be unaffected. The samples must be taken at the same location and depth and under the same conditions in the course of successive sampling operations.

EU Directive 86/278/EEC (entry into force 18/6/1986) dealt with the regulation of the use of sewage sludge in agriculture in such a way as to prevent harmful effects on soil, vegetation, animals and man, thereby encouraging the correct use of such sewage sludge. Member States should prohibit the use of sludge where the concentration of one or more heavy metals in the soil exceeds the limit values which they lay down. Member States should prohibit the use of sludge or the supply of sludge for use on:

- 1 grassland or forage crops if the grassland is to be grazed or the forage crops to be harvested before a certain period has elapsed
- 2 soil in which fruit and vegetable crops are growing, with the exception of fruit trees and ground intended for the cultivation of fruit and vegetable crops which are normally in direct contact with the soil and normally eaten raw.

The purpose of EU Directive 91/157/EEC (entry into force 25/3/1991) was to approximate and converge the laws of the Member States on the recovery and controlled disposal of those spent batteries and accumulators containing dangerous substances. The marketing of:

- 1 alkaline manganese batteries for prolonged use in extreme conditions containing more than 0.05% of mercury by weight
- 2 all other alkaline manganese batteries containing more than 0.025% of mercury by weight is prohibited as from 1/1/1993.

Alkaline manganese button cells and batteries composed of button cells shall be exempted from this prohibition. The marking must include the following indications: separate collection, where appropriate, recycling and the heavy-metal content.

EU Directive 92/112/EEC (entry into force 15/6/1993) laid down procedures for harmonizing the programs for the reduction and eventual elimination of pollution from existing industrial establishments and is intended to improve the conditions of competition in the titanium dioxide industry. The dumping of any solid waste, strong acid waste, treatment waste, weak acid waste, or neutralized waste, was prohibited with effect from 15/6/1993. Member States should take the necessary measures to ensure that discharges of waste into inland surface waters, internal coastal waters, territorial waters, the high sea and the atmosphere are prohibited.

EU Directive 94/62/EC (entry into force 31/12/1994) aimed at harmonizing national measures concerning the management of packaging and packaging waste in order to prevent any impact thereof on the environment of all Member States as well as of third countries or to reduce such impact, thus providing a high level of environmental protection and to ensure the functioning of the internal market and to avoid obstacles to trade and distortion and restriction of competition within the Community. It covered all packaging placed on the market in the Community and all packaging waste, whether it is used or released at industrial, commercial, office, shop, service, household or any other level, regardless of the material used and shall apply without prejudice to existing quality requirements for packaging such as those regarding safety, the protection of health and the hygiene of the packed products or to existing transport requirements. Member States may encourage reuse systems of packaging, which can be reused in an environmentally sound manner. Moreover, they should encourage the use of materials obtained from recycled packaging waste for the manufacturing of packaging and other products.

The purpose of EU Directive 96/59/EC (entry into force 16/9/1996) was to approximate the laws of the Member States on the controlled disposal of PCBs, the decontamination or disposal of equipment containing PCBs and/or the disposal of used PCBs in order to eliminate them completely. Member States should take the necessary measures to ensure that used PCBs are disposed of and PCBs and equipment containing PCBs are decontaminated or disposed of as soon as possible. Member States should take the necessary measures to ensure that used PCBs and equipment containing PCBs are transferred to licensed undertakings and should take the necessary measures to prohibit any incineration of PCBs and/or used PCBs on ships.

EU Directive 2000/53/EC (entry into force 21/10/2000) laid down measures targeting the prevention of waste from vehicles and the re-use, recycling and other forms of recovery of end-of life vehicles and their components. In order to promote the prevention of waste, Member States shall encourage:

- 1 vehicle manufacturers to limit the use of hazardous substances in vehicles and to reduce them as far as possible
- 2 the design and production of new vehicles which take into full account and facilitate the dismantling, re-use and recovery, in particular the recycling
- 3 vehicle manufacturers to integrate an increasing quantity of recycled material in vehicles and other products.

Member States shall ensure materials and components of vehicles put on the market after 1/7/2003 do not contain lead, mercury, cadmium or hexavalent chromium.

EU Directive 2002/95/EC (entry into force 13/2/2003) tried to approximate the laws of the Member States on the restrictions of the use of hazardous substances in electrical and electronic equipment and to contribute to the protection of human health and the environmentally sound recovery and disposal of waste electrical and electronic equipment. This Directive does not apply to spare parts for the repair or to the re-use of electrical and electronic equipment put on the market before 1/7/2006. Member States shall ensure that, from 1/7/2006, new electrical and electronic equipment put on the market does not contain lead, mercury, cadmium, hexavalent chromium, PBBs or PBDEs.

The aim of EU Directive 2002/96/EC (entry into force 13/2/2003) is the prevention of waste electrical and electronic equipment (WEEE) and the re-use, recycling and other forms of recovery of such wastes so as to reduce the disposal of waste. It also seeks to improve the environmental performance of all operators involved in the life cycle of electrical and electronic equipment. Member States shall encourage the design and production of electrical and electronic equipment which take into account and facilitate dismantling and recovery, in particular the re-use and recycling of WEEE, their components and materials. They shall adopt appropriate measures in order to minimize the disposal of WEEE and to achieve a high level of separate collection of WEEE.

All the EU Directives, Proposals for a Directive and Green Paper dealing with waste management – specific waste are given in Table 4.10.

Waste management – incineration of waste

The objective of EU Directive 94/67/EC (entry into force 31/12/1994) was to provide for measures and procedures to prevent or, where that is not practical, to reduce as far as possible, negative impact on the environment, in particular the pollution of air, soil, surface and groundwater, and the resulting risks to human health, from the incineration of hazardous waste and, to that end, to set up and maintain appropriate operating conditions and emission limit values for hazardous waste incineration plants within the Community. It applies without prejudice to other relevant Community legislation, in particular relating to waste and the protection of the health and safety of workers at

Table 4.10 EU Directives, Proposals for a Directive and Green Paper (main points and comments) dealing with waste management – specific waste

Directive	Title	Main points	Comments
EU 75/439/EEC (entry into force 18/6/1977)	The disposal of waste oil	<ul style="list-style-type: none"> ● Application to any mineral-based lubrication or industrial oils ● Any discharge into inland surface water, ground-water, territorial seawater and drainage systems, any deposit and/or discharge harmful to the soil and any uncontrolled discharge of residues resulting from the processing of waste oils and any processing causing air pollution which exceeds the level prescribed by existing provisions is prohibited ● No authorization for mixing of waste oils with PCBs and PCTs or with toxic and dangerous wastes 	<p>Amendments – Directive</p> <ul style="list-style-type: none"> > EU 87/101/EEC (entry into force 1/1/1990) > EU 91/692/EEC (entry into force 1/1/1995) > EU 2000/76/EC (entry into force 28/12/2000) <ul style="list-style-type: none"> ● Amendment and correction of articles
EU 78/176/EEC (entry into force 21/2/1979)	Titanium dioxide industrial waste	<ul style="list-style-type: none"> ● Waste-disposal procedures take due account of human health and environmental considerations ● Any discharge, dumping, storage, accumulation or injection of waste will require prior authorization by the competent Member State authority ● Programs for the gradual reduction, and ultimate elimination, of pollution caused by waste from old manufacturing facilities 	<p>Amendments – Directive</p> <ul style="list-style-type: none"> > EU 82/883/EEC (entry into force 9/12/1984) > EU 83/29/EEC (entry into force 28/1/1983) > EU 91/692/EEC (entry into force 1/1/1993) <ul style="list-style-type: none"> ● Correction of articles
EU 82/883/EEC (entry into force 9/12/1984)	Procedures for the surveillance and monitoring of environments concerned by waste from the titanium dioxide industry	<ul style="list-style-type: none"> ● Application for discharge into water, the land surface, underground strata and the air of waste from the manufacture of titanium dioxide ● Surveillance and monitoring of the environments affected ● Flooding or natural disaster or on account of exceptional weather conditions 	<p>Amendments</p> <ul style="list-style-type: none"> > Regulation No 807/2003 (entry into force 5/6/2003) <ul style="list-style-type: none"> ● Amendment of the annex
EU 86/278/EEC (entry into force 18/6/1986)	The protection of the environment, and in particular of the soil, when sewage sludge is used in agriculture	<ul style="list-style-type: none"> ● Limit values for concentrations of heavy metals in the soil, in sludge and for the maximum annual quantities of heavy metals ● Use of sewage sludge is prohibited if the concentration of one or more heavy metals in the soil ● Sludge must be treated before being used in agriculture 	
EU 91/157/EEC (entry into force 25/3/1991)	Batteries and accumulators containing certain dangerous substances	<ul style="list-style-type: none"> ● Alkaline batteries designed for prolonged use in extreme conditions and containing more than 0.05% by weight of mercury and any other alkaline battery with a mercury content of more than 0.025% by weight ● Batteries of the 'button' type or those composed of elements of the 'button' type ● Programs aimed primarily at reducing the heavy-metal content of batteries and accumulators 	<p>Amendments</p> <ul style="list-style-type: none"> > Directive EU 93/86/EEC (entry into force 11/10/1993) > Directive EU 98/101/EC (entry into force 25/1/1999) <ul style="list-style-type: none"> ● Amendment of annexes

(Continued)

Table 4.10 (Continued)

Directive	Title	Main points	Comments
EU 92/112/EEC (entry into force 15/6/1993)	Procedures for harmonizing the programs for the reduction and eventual elimination of pollution caused by waste from the titanium dioxide industry	<ul style="list-style-type: none"> ● Application for solid waste, strong acid waste, weak acid waste, neutralized waste, treatment waste and dust ● Dumping of any waste from ships or aircrafts ● Discharges into territorial waters and the high sea of solid waste and strong acid waste from existing industrial establishments ● Discharges into the atmosphere are reduced in accordance with the limit values 	
EU 94/62/EC (entry into force 31/12/1994)	Packaging and packaging waste	<ul style="list-style-type: none"> ● All packaging waste, whether it is used or released at industrial, commercial, office, shop, service, household or any other level, regardless of the material used ● Member States must introduce systems for the return and/or collection of used packaging to attain specific targets ● No later than 31/12/2007, the European Parliament and the Council will fix targets for 2009–2014 	Amendments > Directive EU 2004/12/EC (entry into force 18/2/2004) > Directive EU 2005/2/EC (entry into force 5/4/2005) ● Amendment of articles
EU 96/59/EC (entry into force 16/9/1996)	The disposal of polychlorinated biphenyls and polychlorinated terphenyls (PCBs/PCTs)	<ul style="list-style-type: none"> ● Necessary measures ensure that used PCBs are disposed of and PCBs and equipment containing PCBs are decontaminated or disposed of ● Inventories must be compiled of equipment with PCB volumes of more than 5 dm³ ● Any equipment which is subject to inventory must be labeled ● Member States must prohibit the separation of PCBs from other substances 	Repeal > Directive EU 76/403/EEC
EU 2000/53/EC (entry into force 21/10/2000)	End-of-life vehicles	<ul style="list-style-type: none"> ● Directive covers any end-of-life vehicle and two- or three-wheel motor vehicles and their components ● Waste prevention ● Provisions on the collection of all end-of-life vehicles ● Member States must ensure that producers use material coding standards 	Amendments > Decision 2002/525/EC (entry into force 1/1/2003) ● The City of Cork shall be designated as the European Capital of Culture 2005 > Decision 2005/63/EC ● Replacement of an article
EU 2002/95/EC (entry into force 13/2/2003)	The restriction of the use of certain hazardous substances in electrical and electronic equipment	<ul style="list-style-type: none"> ● Directive covers the same scope as the Directive on waste electrical and electronic equipment. It also applies to electric light bulbs and luminaires in households ● From 1/7/2006, lead, mercury, cadmium, hexavalent chromium, PBBs and PBDEs in electrical and electronic equipment must be replaced by other substances 	Amendment > Directive EU 2003/108/EC (entry into force 31/12/2003) ● Replacement of annexes
EU 2002/96/EC (entry into force 13/2/2003)	Waste electrical and electronic equipment	<ul style="list-style-type: none"> ● Specific categories of electrical and electronic equipment 	Amendment > Directive EU 2003/108/EC

(Continued)

Table 4.10 (Continued)

Directive	Title	Main points	Comments
COM(2003) 319 final Not published in the Official Journal	Proposal for a Directive of the European Parliament and of the Council on the management of waste from the extractive industries	<ul style="list-style-type: none"> • Disposal of waste electrical and electronic equipment (WEEE) as unsorted municipal waste and are to set up separate collection systems for WEEE • Producers of electrical and electronic equipment must apply the best available treatment, recovery and recycling techniques • Application for waste resulting from extraction, processing and storage of mineral resources and the working of quarries • Operators of the waste facility draw up a waste management plan • Operator of a waste management facility takes the measures necessary to prevent water and soil contamination 	<p>(entry into force 31/12/2003)</p> <ul style="list-style-type: none"> • Replacement of annexes
COM(2004) 162 final Not published in the Official Journal	Proposal for a European Parliament and Council Directive of 11 March 2004 on the type-approval of motor vehicles with regard to their re-usability, recyclability and recoverability	<ul style="list-style-type: none"> • Re-use of some component parts in the construction of new vehicles is banned • Application for cars, station wagons and people carriers and to light-duty trucks, new models and models already in production • No application for special purpose vehicles, for multi-stage built light-duty vehicles or for vehicles produced in small series 	<p>Amendment > Directive EU 70/156/EEC</p> <ul style="list-style-type: none"> • Replacement of articles
Green Paper of 26 July 2000	Environmental issues of PVC	<ul style="list-style-type: none"> • Two main questions: (a) environmental and health questions concerning the use of certain additives in PVC and (b) the question of waste management • Presentation of a range of policy options for reducing the impact on human health and the environment 	

Adapted from Arvanitoyannis *et al.*, 2006c

incineration plants. Permits shall be granted only if the application shows that the incineration plant is designed, equipped and will be operated in such a manner that the appropriate preventive measures against environmental pollution will be taken.

The aim of EU Directive 2000/76/EC (entry into force 28/12/2000) was to prevent or to limit, as far as practicable, negative effects on the environment, in particular pollution by emissions into air, soil, surface water and groundwater, and the resulting risks to human health, from the incineration and co-incineration of waste. It covers incineration and co-incineration plants. The following plants shall however be excluded:

- 1 plants treating vegetable waste from agriculture and forestry, vegetable waste from the food processing industry, fibrous vegetable waste from virgin pulp production and from production of paper from pulp, wood waste, cork waste, radioactive waste, animal carcasses, waste resulting from the exploration for, and the exploitation of, oil and gas resources.

Table 4.11 EU Directives (main points and comments) for waste management – incineration of waste

Directive	Title	Main points	Comments
EU 94/67/EC (entry into force 31/12/1994)	The incineration of hazardous waste	<ul style="list-style-type: none"> ● Before an incineration plant can become operational ● Analytical report each time waste is delivered ● General and specific conditions governing the design and operation of incineration plants ● Emission threshold values comparable to those obtainable with the best available technologies 	The Directive will be repealed on 28/12/2005 by EU Directive 200/76/EC, relating to the incineration of waste
EU 2000/76/EC (entry into force 28/12/2000)	The incineration of waste	<ul style="list-style-type: none"> ● Directive does not cover experimental plants for improving the incineration process ● All incineration or co-incineration plants must be authorized ● Limit values for incineration plant emissions to atmosphere ● Quantity and harmfulness of incineration residues must be reduced to a minimum and residues must be recycled 	Repeals > Directive EU 89/369/EEC > Directive EU 89/429/EEC

Adapted from Arvanitoyannis *et al.*, 2006c

2 experimental plants used for research, development and testing in order to improve the incineration process and which treat less than 50 tonnes of waste per year. No incineration or co-incineration plant shall operate without a permit to carry out these activities. Incineration plants shall be operated in order to achieve a level of incineration such that the slag and bottom ashes total organic carbon (TOC) content is less than 3% or their loss on ignition is less than 5% of the dry weight of the material.

A summary of the EU Directives related to waste management – incineration of waste is found in Table 4.11.

Waste management – hazardous waste

The object of Directive 91/689/EEC (entry into force 19/12/1991) was to approximate the laws of the Member States on the controlled management of hazardous waste. Member States shall take the necessary measures:

- 1 to require that on every site where tipping of hazardous waste takes place the waste is recorded and identified
- 2 to require that establishment and undertaking which dispose of, recover, collect or transport hazardous waste do not mix different categories of hazardous waste or mix hazardous waste with non-hazardous waste
- 3 to ensure that, in the course of collection, transport and temporary storage, waste is properly packaged and labeled.

Decision 93/98/EEC (entry into force 1/1/1993): the Convention (text attached as Annex to the Decision) aimed at introducing a system for controlling the export,

import and disposal of hazardous wastes, to reduce the volume of such exchanges so as to protect human health and the environment. A transboundary movement is any movement of hazardous wastes or other wastes from an area under the national jurisdiction of one State to or through an area under the national jurisdiction of another State. General obligations:

- 1 it is prohibited to export or import hazardous wastes or other wastes to or from a non-party State
- 2 no wastes may be exported if the State of import has not given its consent in writing to the specific import
- 3 information about proposed transboundary movements must be communicated to the States concerned, by means of a notification form, so that they may evaluate the effects of the proposed movements on human health and the environment
- 4 transboundary movements of wastes must only be authorized where there is no danger attaching to their movement and disposal
- 5 wastes which are to be the subject of a transboundary movement must be packaged, labeled and transported in conformity with international rules, and must be accompanied by a movement document from the point at which a movement commences to the point of disposal
- 6 any party may impose additional requirements that are consistent with the provisions of the Convention.

A summary of the EU Directive and Decisions related to waste management – hazardous waste is given in Table 4.12.

Waste management – radioactive waste and substances

Regulation (EC) No 1493/93 (entry into force 9/7/1993) shall apply to shipments, between Member States, of sealed sources and other relevant sources, whenever the quantities and concentrations exceed the levels laid down. It shall also apply to shipments of radioactive waste between Member States. A holder of sealed sources or radioactive waste who intends to carry out a shipment of such sources or waste, or to arrange for such a shipment to be carried out, shall obtain a prior written declaration by the consignee of the radioactive substances to the effect that the consignee has complied, in the Member State of destination, with all applicable provisions and with relevant national requirements for safe storage, use or disposal of that class of source or waste.

The Proposal for a Council Directive (Euratom) on the management of spent nuclear fuel and radioactive waste (COM(2003) 32 final – not published in the Official Journal) shall apply to all stages of spent nuclear fuel management and obliges Member States to:

- 1 take all necessary measures to ensure that spent nuclear fuel and radioactive waste are managed in such a way that individuals, society and the environment are protected against radiological hazards

Table 4.12 EU Directive and Decisions (main points and comments) related to waste management – hazardous waste

Directive	Title	Main points	Comments
EU 91/689/EEC (entry into force 19/12/1991)	Hazardous waste	<ul style="list-style-type: none"> • List of the hazardous wastes covered by the Directive • Any establishment or undertaking which carries out disposal operations must obtain a permit • Competent authorities publish plans for the management of hazardous waste and the Commission evaluates these plans 	Amendment > Directive EU 94/31/EC (entry into force 22/7/1994) <ul style="list-style-type: none"> • Substitution of an article
Decision 93/98/EEC (entry into force 1/1/1993)	The conclusion, on behalf of the Community, of the Convention on the control of transboundary movements of hazardous wastes and their disposal (Basle Convention)	<ul style="list-style-type: none"> • EEC approves the Convention on the control of transboundary movements of hazardous wastes and their disposal • Introducing a system for controlling the export, import and disposal of hazardous wastes and their disposal, to reduce the volume of such exchanges so as to protect human health and the environment 	
Decision 97/640/EC (entry into force 22/6/1997)	The approval, on behalf of the Community, of the amendment to the Convention on the control of transboundary movements of hazardous wastes and their disposal (Basle Convention)	<ul style="list-style-type: none"> • Establishment of notification procedures regarding transboundary movements between parties and transboundary movements from a party through the territory of States which are not parties 	

Adapted from Arvanitoyannis *et al.*, 2006c

- 2 ensure that the production of radioactive waste is kept to the minimum level possible
- 3 take all the necessary legislative, regulatory and administrative measures and other steps required to ensure the safe management of spent nuclear fuel and radioactive waste
- 4 establish or designate a regulatory body entrusted with the implementation of the legislative and regulatory framework
- 5 guarantee adequate financial resources to support the management of spent nuclear fuel
- 6 ensure effective public information.

Council Directive 92/3/Euratom of 3 February 1992 referred to the supervision and control of shipments of radioactive waste between Member States and into and out of the Community whenever the quantities and concentration exceed the levels laid down. A holder of radioactive waste who intends to carry out a shipment of such waste or to arrange for such a shipment to be carried out should submit an application for authorization to the competent authorities of the country of origin. These competent authorities sent such applications for approval to the competent authorities of the country of destination and of the country or countries of transit, if any. Where waste

falling within the scope of this Directive was to enter the Community from a third country and the country of destination is a Member State, the consignee shall submit an application for authorization to the competent authorities of that Member State. Where a sealed source was returned by its user to the supplier of the source in another country, its shipment should not fall within the scope of this Directive.

Communication and fourth report from the Commission of 11 January 1999 on the present situation and prospects for radioactive waste management in the EU contained detailed information on the waste arising from the first three activities in five year periods up to year 2020 for all Member States, and general information on the processing of material. The report distinguishes between:

- 1 low and intermediate-level waste (non-heat-generating) of both short (up to 30 years) and long half-life
- 2 high-level waste, which includes vitrified residues from reprocessing and conditioned spent fuel declared as being radioactive waste.

The titles, main points and comments of the EU Regulation, Proposal for a Directive and Communication about waste management – radioactive waste and management are summarized in Table 4.13.

Air pollution

Air pollution became a serious and widespread problem during the last century. There have been several documented episodes of air pollution in which loss of human lives occurred. In 1931, in the heavily industrialized area of Manchester (UK), more than 500 people lost their lives by being exposed to particulates and acids in the air. In 1948, in the steel town of Donora, Pennsylvania (USA), about 20 people died and several thousand became ill from the effects of airborne contaminants. In 1994, an estimated 3000 cancer deaths annually were attributed to second hand tobacco smoke alone (Ray, 1995). Organic pollutants in terrestrial environments are of concern because of potential environmental changes caused by direct adverse effects on the indigenous animal populations and because of the potential transmission of these compounds to humans through the food chain. These two situations may lead to two different evaluations of a given level of environmental contamination. In the case of potential human exposure, the primary concern often is the exposure to potential mutagens and carcinogens. These materials are of more serious consequence to humans than to animal species because medical science allows the retention of many adverse mutations in the human (Fries, 1991). The atmosphere, which makes up the largest fraction of the biosphere, is a dynamic system that continuously absorbs a wide range of solids, liquids and gases from both natural and man-made sources. These substances travel through air, disperse and react with one another and with other substances both physically and chemically. Most of these constituents eventually find their way into a depository such as the ocean, or to a receptor such as man. Some substances, such as helium, however, escape from the biosphere. Others, such as carbon dioxide, may enter the atmosphere faster than

Table 4.13 EU Regulation, Proposal for a Directive and Communication (main points and comments) for waste management – radioactive waste and management

Directive	Title	Main points
Regulation (EC) No 1493/93 (entry into force 9/7/1993)	Shipments of radioactive substances between Member States	<ul style="list-style-type: none"> • Shipments between Member States of sealed sources and other relevant sources • Shipments of radioactive waste between Member States • Shipment of certain substances
COM(2003) 32 final Not published in the Official Journal	Proposal for a Council Directive (Euratom) on the management of spent nuclear fuel and radioactive waste	<ul style="list-style-type: none"> • All stages of spent nuclear fuel management • National programs for the disposal of radioactive waste in general and deep disposal of high-level radioactive waste • Shipments of radioactive waste or spent fuel to another Member State or third country
Council Directive 92/3/Euratom of 3 February 1992	Regarding the supervision and control of shipments of radioactive waste between Member States and into and out of the Community	<ul style="list-style-type: none"> • Shipments of radioactive waste between the Member States and shipments entering and/or leaving the Community • Mandatory system of notification and a uniform control document for the transfer of radioactive waste • All shipments of radioactive waste between Member States and into and out of the Community
Communication and fourth report from the Commission of 11 January 1999	The present situation and prospects for radioactive waste management in the European Union	<ul style="list-style-type: none"> • Strategy towards public safety and environmental protection • Its approach is one of harmonization at Community level of radioactive waste management principles and practices to ensure an equivalent and acceptable level of safety • Radioactive waste results from four types of activity: nuclear electricity generation, the operation of research reactors, the use of radiation and radioactive material in medicine, agriculture, industry and research and processing of material containing natural radionuclides

Adapted from Arvanitoyannis *et al.*, 2006c

they enter a reservoir and thus gradually accumulate in the air (Rao and Rao, 1989). Air consists of nitrogen, oxygen, water vapor and inert gases. Human activities can release substances into the air, some of which can cause problems for humans, plants and animals. There are several main types of pollution including smog, acid rain, the greenhouse effect and 'holes' in the ozone layer (www.lbl.gov/Education/ELSI/pollution-main.html). Moreover, air pollution can have disastrous consequences on agriculture close to pollutant sources. Such impacts on agricultural productivity can have serious implications where problems of food scarcity exist (www.geocities.com/sebindia/01_04/04-04-1.html). The effects of air pollution on health are very complex as there are many different sources and their individual effects vary from one to another. Air pollution is aggravated because of increasing traffic, growing cities, rapid economic development and industrialization (<http://edugreen.teri.res.in/explore/air/air.htm>). Pollutants can be classified as either primary or secondary. Primary pollutants are substances directly produced by a process, while secondary pollutants are not emitted. They are formed in the air when primary pollutants react or interact (<http://www.epa>.

nsw.gov.au/envirom/princairpol.htm). Major air pollutants include carbon monoxide (CO), carbon dioxide (CO₂), chlorofluorocarbons (CFC), lead (Pb), ozone (O₃), nitrogen oxides (NO_x), suspended particulate matter (SPM) and sulfur dioxide (SO₂) (<http://edugreen.teri.res.in/explore/air/air.htm>). Organic priority pollutants, defined by the United States Environmental Protection Agency (USEPA) and the European Community (EC), include organochlorine pesticides, polychlorinated biphenyls (PCBs), halogenated aliphatic hydrocarbons, halogenated ethers, monocyclic aromatics, phthalate acid esters, polynuclear aromatic hydrocarbons (PAHs) and other miscellaneous compounds. Many of these pollutants come from industrial sources, i.e. petroleum refining, organic chemicals and synthetic industries, still milling and coal conversion, textile processing and pulp and paper milling (Wild and Jones, 1991). The Clean Air Act lists 188 toxic air pollutants as hazardous. Some toxic air pollutants remain in the environment for only short periods of time. On the other hand, other toxic air pollutants, break down slowly in the environment and can be redeposited many times. Additionally, they build up in the body and concentrate as they rise through the food chain (www.healthfoods.com/Education/Environment_Information/Air_Pollution/toxic_air_pollutants.htm). There are three methods of identifying air pollution:

- 1 sensory recognition
- 2 physical measurement of pollution
- 3 effects on plants, animals and buildings (Rao and Rao, 1989).

In an attempt to reach a significant reduction in air pollution, the United Nations Framework Convention on Climate Change (1992) and the Kyoto Protocol (1997) were adopted. In order to make progress towards the target, the Community has approved a program on climate change and a communication on its implementation (COM(2001) 580). The Commission further published a Green Paper on greenhouse gas emissions trading within the EU. The Community is also a party to the Geneva Convention on Long-Range Transboundary Air Pollution (Decision 81/462/EEC) and to the International Protocols on Acidifying Substances which complement that Convention. Community legislation in this field is principally aimed at reducing emissions from industrial activities and road vehicles. Where transport is concerned, the strategy is to reduce polluting emissions, to reduce the fuel consumption of private cars and to promote clean vehicles. In an attempt to improve air quality, a global strategy was adopted in May 2001 and several Directives have been or are being adopted (<http://europa.eu.int/scadplus/leg/en/lvb/l28066.htm>).

Air pollution – air quality

EU Directive 82/884/EEC (entry into force 9/12/1982) fixed an upper limit value for lead in the air specifically in order to help protect human beings against the effects of lead in the environment and shall not apply to occupational exposure. The limit value was 2 mg Pb/m³ expressed as an annual mean concentration. Member States shall ensure that sampling stations are installed and operated at places where individuals may be exposed continually for a long period.

The purpose of EU Directive 85/203/EEC (entry into force 26/3/1985) was to fix an upper limit value for nitrogen dioxide in the atmosphere to help protect human beings against the effects of nitrogen dioxide in the environment and to lay down guide values for nitrogen dioxide in the atmosphere in order to improve the protection of human health and contribute to the long-term protection of the environment. The Directive has no application for exposure at work or inside buildings. Member States shall take the necessary measures to ensure that as from 1/7/1987 the measured concentrations of nitrogen dioxide in the atmosphere are not greater than the limit value.

The general aim of EU Directive 96/62/EC (entry into force 21/11/1996) was to define the basic principles of a common strategy to:

- 1 define and establish objectives for ambient air quality in the Community designed to avoid, prevent or reduce harmful effects on human health and the environment as a whole
- 2 assess the ambient air quality in Member States on the basis of common methods and criteria
- 3 obtain adequate information on ambient air quality and ensure that it is made available to the public, inter alia by means of alert thresholds
- 4 maintain ambient air quality where it is good and improve it in other cases.

The atmospheric pollutants to be taken into consideration in the assessment and management of ambient air quality are: sulfur dioxide, nitrogen dioxide, fine particulate matter such as soot, suspended particulate matter, lead, ozone, benzene, carbon monoxide, polyaromatic hydrocarbons, cadmium, arsenic, nickel and mercury. When the alert thresholds are exceeded, Member States shall undertake to ensure that the necessary steps are taken to inform the public.

The object of EU Directive 1999/30/EC (entry into force 19/7/1999) was to:

- 1 establish limit values and, as appropriate, alert thresholds for concentrations of sulfur dioxide, nitrogen dioxide and oxides of nitrogen, particulate matter and lead in ambient air intended to avoid, prevent or reduce harmful effects on human health and the environment as a whole
- 2 assess concentrations of sulfur dioxide, nitrogen dioxide and oxides of nitrogen, particulate matter and lead in ambient air on the basis of common methods and criteria
- 3 obtain adequate information on concentrations of sulfur dioxide, nitrogen dioxide and oxides of nitrogen, particulate matter and lead in ambient air and ensure that it is made available to the public
- 4 maintain ambient air quality where it is good and improve it in other cases.

Member States shall ensure that up-to-date information on ambient concentrations of sulfur dioxide, nitrogen dioxide and oxides of nitrogen, particulate matter and lead is routinely made available to the public as well as to appropriate organizations such as environmental organizations and consumer organizations.

EU Directive 2001/81/EC (entry into force 27/11/2001) aims at limiting emissions of acidifying and eutrophying pollutants and ozone precursors in order to improve the

protection in the Community of the environment and human health against risks of adverse effects from acidification, soil eutrophication and ground-level ozone and to move towards the long-term objectives of not exceeding critical levels and loads and of effective protection of all people against recognized health risks from air pollution by establishing national emission ceilings, taking the years 2010 and 2020 as benchmarks. It covers emissions in the territory of Member States and their exclusive economic zones from all sources of the pollutants which arise as a result of human activities. By the year 2010 at the latest, Member States shall limit their annual national emissions of the pollutants sulfur dioxide (SO₂), nitrogen oxides (NO_x), volatile organic compounds (VOC) and ammonia (NH₃) to amounts not greater than the emission ceilings laid down.

Regulation (EC) No 2037/2000 (entry into force 30/9/2000) applies to the production, importation, exportation, placing on the market, use, recovery, recycling and reclamation and destruction of chlorofluorocarbons, other fully halogenated chlorofluorocarbons, halons, carbon tetrachloride, 1,1,1-trichloroethane, methyl bromide, hydrobromofluorocarbons and hydrochlorofluorocarbons, to the reporting of information on these substances and to the importation, exportation, placing on the market and use of products and equipment containing those substances. The production of the previous substances shall be prohibited. The release for free circulation in the Community or inward processing of controlled substances shall be subject to the presentation of an import licence. Controlled substances contained in:

- 1 refrigeration, air-conditioning and heat pump equipment, except domestic refrigerators and freezers
- 2 equipment containing solvents
- 3 fire protection systems and fire extinguishers shall be recovered for destruction by technologies approved by the Parties or by any other environmentally acceptable destruction technology, or for recycling or reclamation during the servicing and maintenance of equipment or before the dismantling or disposal of equipment.

CFCs are categories of one of the substances depleting the ozone layer whose production and consumption was prohibited in the Community in 1995. However, they are still available for use in metered dose inhalers for the treatment of asthma and chronic obstructive pulmonary disease (COPD) by virtue of a derogation for essential uses provided for in the Montreal Protocol and in Regulation (EC) No 3093/94. The Communication aimed at presenting a transitional strategy for the phaseout of CFCs in metered dose inhalers. As soon as technically and economically acceptable substitute solutions are available, CFCs will have to be withdrawn. A certain number of inhalers without CFCs have already been successfully placed on the Community market. It also promoted the early transition of all patients in the Community to treatments without CFCs.

Decision 97/101/EC (entry into force 1/1/1997) established a reciprocal exchange of information and data from networks and individual stations measuring ambient air pollution. It should apply to networks and stations, covering detailed information describing the air-pollution monitoring networks and stations operating in the Member States

and measurements of air quality obtained from stations. The information to be communicated to the Commission should concern the characteristics of the measurement stations, the measurement equipment and the operational procedures followed in those stations and the structure and organization of the network to which they belong.

Decision 2001/379/EC aims at controlling emissions of heavy metals caused by anthropogenic activities that are subject to long-range transboundary atmospheric transport and that are likely to have significant adverse effects on human health or the environment. It stipulates the reduction of total annual emissions into the atmosphere of cadmium, lead and mercury, and the application of product control measures.

All the EU Directives, Regulation, Communications and Decisions related to air pollution – air quality are given in Table 4.14.

Table 4.14 EU Directives, Regulation, Communications and Decisions (main points and comments) focused on air pollution – air quality

Directive	Title	Main points	Comments
EU 82/884/EEC (entry into force 9/12/1982)	Limit value for lead in the air	<ul style="list-style-type: none"> • Limit value for lead in the air and a sampling method and procedure • Monitoring the areas where persons may continuously be exposed to lead during a long period • Member States shall inform the Commission annually of areas where the limit value has been exceeded 	Amendment > Directive EU 91/692/EEC (entry into force 23/12/1991) <ul style="list-style-type: none"> • Replacement of articles
EU 85/203/EEC (entry into force 26/3/1985)	Air quality standards for nitrogen dioxide	<ul style="list-style-type: none"> • Limit value which may not be exceeded throughout the Member States during specified periods and guide values specified • Reference method for analyzing concentrations of nitrogen dioxide and specifications for the measuring stations 	On 19/7/2001, the Directive was partly repealed by Directive EU 1999/30/EC relating to limit values for sulfur dioxide, nitrogen dioxide and oxides of nitrogen, particulate matter and lead in ambient air. It will be fully repealed in 2010
EU 96/62/EC (entry into force 21/11/1996)	Ambient air quality assessment and management	<ul style="list-style-type: none"> • Strategy for establishing quality objectives for ambient air • Limit values and alert thresholds for sulfur dioxide, nitrogen dioxide and oxides of nitrogen, particulate matter and lead-benzene and carbon monoxide-ozone-PAH, cadmium, arsenic, nickel and mercury • Program for attaining limit values a set deadline • A list of the areas and conurbations where pollution levels exceed the limit values 	Amendment > Regulation (EC) No 1882/2003 (entry into force 20/11/2003) <ul style="list-style-type: none"> • Amendment of articles
EU 1999/30/EC (entry into force 19/7/1999)	Limit values for sulfur dioxide, nitrogen dioxide and oxides of nitrogen,	<ul style="list-style-type: none"> • Council adopted limit values and alert thresholds for a number of specific pollutants 	Amendment > Decision 2001/714/EC (entry into force 2/10/2001)

(Continued)

Table 4.14 (Continued)

Directive	Title	Main points	Comments
	particulate matter and lead in ambient air	<ul style="list-style-type: none"> Member States must ensure that up-to-date information on ambient concentrations of pollutants is routinely made available to the public and to appropriate bodies 	<ul style="list-style-type: none"> Amendment of annex V relating to limit values for sulfur dioxide, nitrogen dioxide and oxides of nitrogen, particulate matter and lead in ambient air Repeals <ul style="list-style-type: none"> > Directive EU 80/779/EEC on air quality limit values and guide values for sulfur dioxide and suspended particulates > Directive EU 82/884/EEC on a limit value for lead in the air > Directive EU 85/203/EEC on air quality standards for nitrogen dioxide
EU 2001/81/EC (entry into force 27/11/2001)	National emission ceilings for certain atmospheric pollutants	<ul style="list-style-type: none"> Purpose of the emission ceilings is to meet specific interim environmental objectives Programs for the progressive reduction of their annual national emissions Update national emission inventories and emission projections for SO₂, NO_x, VOC and NH₃ Commission must report to the European Parliament and the Council on progress on the implementation of the ceilings 	
Regulation (EC) No 2037/2000 (entry into force 30/9/2000)	Substances that deplete the ozone layer	<ul style="list-style-type: none"> Application for the production, importation, exportation, placing on the market, use, recovery, recycling and/or regeneration of specific substances, the information to be notified concerning these substances, inspections and penalties and new substances Phased restriction on the use, placing on the market, production and importation of virgin HCFCs Minimum training requirements for personnel responsible for maintaining equipment containing those substances by 31/12/2001 	Amendments – Regulation (EC) <ul style="list-style-type: none"> > No. 2038/2000 (entry into force 30/9/2000) • Addition in an article > No. 2039/2000 (entry into force 30/9/2000) • Addition in an article Repeal <ul style="list-style-type: none"> > Regulation (EC) No 3093/94
Communication from the Commission to the European Parliament and to the Council of 23 October 1998	The phaseout of CFCs in metered dose inhalers	<ul style="list-style-type: none"> As soon as technically and economically acceptable substitute solutions are available, CFCs will have to be withdrawn 	

(Continued)

Table 4.14 (Continued)

Directive	Title	Main points	Comments
Decision 97/101/EC (entry into force 1/1/1997)	Establishment of a reciprocal exchange of information and data from networks and individual stations measuring ambient air pollution within the Member States	<ul style="list-style-type: none"> • Introduction of a reciprocal exchange of information and data relating to the networks and stations set up in the Member States to measure air pollution and to the air quality measurements taken by those stations • All data to be sent by the Member States to the Commission 	Amendment > Decision 2001/752/EC (entry into force 26/10/2001) • Replacement of annexes
Decision 2001/379/EC The approval, on behalf of the European Community, of the Protocol to the 1979 Convention	Long-range transboundary air pollution on heavy metals	<ul style="list-style-type: none"> • To reduce emissions from heavy metals caused by anthropogenic activities that are subject to long-range transboundary atmospheric transport and are likely to have serious adverse effects on human health and the environment • Signatory parties will encourage research and development, monitoring and cooperation with regard to heavy metals 	

Adapted from Arvanitoyannis *et al.*, 2006b

Air pollution – motor vehicles

EU Directive 70/220/EEC states that no Member State may refuse to grant EEC type approval or national type approval of a vehicle on grounds relating to air pollution by gases from positive-ignition engines of motor vehicles. The Member State which has granted type approval shall take the necessary measures to ensure that it is informed of any modification of a part or characteristic referred.

EU Directive 88/77/EEC (entry into force 16/12/1987) claimed that, from 1/7/1988, no Member State may, on grounds relating to the gaseous pollutants emitted from an engine:

- 1 refuse to grant EEC type-approval
- 2 prohibit the registration, sale, entry into service or use of such new vehicles
- 3 refuse to grant EEC type-approval, or to grant national type-approval for a type of diesel engine
- 4 prohibit the sale or use of new diesel engines.

From 1/7/1988, Member States may, on grounds relating to gaseous pollutants emitted from an engine:

- 1 refuse to grant national type-approval for a type of vehicle propelled by a diesel engine
- 2 refuse to grant national type-approval for a diesel-engine type.

EU 93/12/EEC should not apply to gas oils: contained in the fuel tanks of vessels, aircraft or motor vehicles crossing a frontier between a third country and a Member State or intended for processing prior to final combustion. Member States shall prohibit the marketing of diesel fuels in the Community if their sulfur compound content exceeds 2% by weight as from 1/10/1994 or 0.05% by weight as from 1/10/1996.

EU Directive 97/68/EC (entry into force 16/12/1987) aims at approximating the laws of the Member States relating to emission standards and type-approval procedures for engines to be installed in non-road mobile machinery. It will contribute to the smooth functioning of the internal market, while protecting human health and the environment. Application for engine or engine family type-approval shall be submitted by the manufacturer to the approval authority of a Member State. The Member State which has granted type-approval must take the necessary measures to ensure that it is informed of any change in the particulars appearing in the information package.

EU Directive 98/70/EC (entry into force 28/12/1998) set technical specifications on health and environmental grounds for fuels to be used for vehicles equipped with positive-ignition and compression-ignition engines. No later than 1/1/2000, Member States shall prohibit the marketing of leaded petrol within their territory. They shall ensure that, no later than 1/1/2000, diesel fuel can be marketed within their territory only if it complies with the environmental specifications set out. The Member States involved shall provide the Commission with data on ambient air quality for the area in question as well as the predicted effects on air quality of the measures proposed.

The purpose of EU Directive 1999/94/EC (entry into force 18/1/2000) is to ensure that information relating to the fuel economy and CO₂ emissions of new passenger cars offered for sale or lease in the Community is made available to consumers in order to enable consumers to make an informed choice. The Member States shall ensure that a label on fuel economy and CO₂ emissions is attached to or displayed, in a clearly visible manner, near each new passenger car model at the point of sale. The Member States shall ensure that, for each make of car, a poster is exhibited with a list of the official fuel consumption data and the official specific CO₂ emissions data of all new passenger car models displayed or offered for sale or lease at or through that point of sale.

EU Directive 2000/25/EC (entry into force 12/7/2000) states that Member States may not after 30/11/2000:

- 1 refuse to grant EC type-approval or national type-approval in respect of an engine type or family
- 2 prohibit the sale, entry into service or use of a new engine
- 3 refuse to grant EC type-approval or national type-approval of tractor types
- 4 prohibit the use, the sale, the initial entry into service of tractor types on grounds relating to air pollution if the pollutants emitted by those engines or the engines fitted to those tractors meet the requirements of the Directive.

Communication from the Commission to the European Parliament and the Council of 20 November 2002, 'A European Union strategy to reduce atmospheric emissions from seagoing ships' (COM(2002) 595), states that emissions from seagoing ships include air pollutants, greenhouse gases and ozone-depleting substances entailing risks for

human health and the environment. The Communication contains a table giving emissions of air pollutants and greenhouse gases from ships in Community waters in 2000 as well as projected emissions for 2010 and their environmental impact. It outlines a number of actions to achieve these objectives, including:

- 1 coordinating the positions of EU Member States within the International Maritime Organization (IMO) to press for tougher measures to reduce ship emissions
- 2 adopting the proposal for a Directive amending EU Directive 1999/32/EC to limit the sulfur content of marine fuels
- 3 amending EU Directive 97/68/EC on NO_x and PM emissions standards from non-road engines
- 4 if the IMO has not proposed tighter international standards by 2007, to bring forward a proposal to reduce NO_x emissions from seagoing vessels
- 5 to remove, by 2010, the exemption which permits the use of halon on board existing cargo ships operating in EU waters.

Decision No 1753/2000/EC establishes a scheme to monitor the average specific emissions of CO₂ from new passenger cars registered in the Community. It applies only to those passenger cars which are being registered in the Community for the first time and have not been registered previously elsewhere.

- 1 For each separate fuel type: the total number of newly registered passenger cars, the average specific emissions of CO₂ for newly registered passenger cars
- 2 For each fuel type and for each distinct CO₂ emission category: the number of newly registered passenger cars, the average specific emissions of CO₂
- 3 For each fuel type and for each distinct mass category: the number of newly registered passenger cars, the average specific emissions of CO₂, the average mass
- 4 For each fuel type and for each distinct maximum net power category specified: the number of newly registered passenger cars, the average specific emissions of CO₂, the average maximum net power
- 5 For each fuel type and for each distinct engine capacity category specified: the number of newly registered passenger cars, the average specific emissions of CO₂, the average engine capacity.

The Commission working paper of 14 July 1998, 'Towards a framework for the solution of the environmental problems caused by traffic of heavy goods vehicles', is the Commission's response to the Council's request, made in 1994, to bring together in one framework a number of specific actions to reduce the environmental problems caused by heavy goods vehicles. These measures, which are based on a number of principles are divided into four 'pillars', namely: charges for road use, railway infrastructure, combined transport facilities and technical standards for vehicles. The Commission proposes several specific measures:

- 1 the development of interoperable road pricing systems in the Member States. Charges would be based on the number of kilometers traveled, measured by systems on board vehicles and, in the longer term, by electronic roadside systems

- 2 the promotion of best practice among companies by means of tax incentives
- 3 development of a common framework for infrastructure charging, applicable in all Member States and to all transport operations.

Some representative points and comments (repeals, modifications, amendments) of the EU Directives, Communication and Decision (main points and comments) for air pollution – motor vehicles are given in Table 4.15.

Table 4.15 EU Directives, Communication and Decision (main points and comments) with regard to air pollution – motor vehicles

Directive	Title	Main points	Comments
EU 70/220/EEC	The approximation of the laws of the Member States relating to measures to be taken against air pollution by emissions from motor vehicles	<ul style="list-style-type: none"> ● Directive covers motor vehicles with spark-ignition and compression-ignition engines ● To encourage advance compliance when new limit values are permitted ● Reports on the development of onboard diagnostic systems and on their extension to other safety-related electronic monitoring systems 	Amendments <ul style="list-style-type: none"> > Directive EU 74/290/EEC > Directive EU 77/102/EEC > Directive EU 78/665/EEC > Directive EU 83/351/EEC > Directive EU 88/76/EEC > Directive EU 88/436/EEC > Directive EU 89/491/EEC > Directive EU 89/458/EEC > Directive EU 91/441/EEC > Directive EU 93/59/EEC > Directive EU 94/12/EC > Directive EU 96/44/EC > Directive EU 96/69/EC > Directive EU 98/69/EC > Directive EU 99/102/EC > Directive EU 2001/1/EC > Directive EU 2001/100/EC ● Amendment of annexes
EU 88/77/EEC (entry into force 16/12/1987)	The approximation of the laws of the Member States relating to the measures to be taken against the emission of gaseous pollutants from diesel engines for use in vehicles	<ul style="list-style-type: none"> ● Limit values for emissions of gaseous and particulate pollutants from all vehicles ● No application for vehicles which run on rails, agricultural tractors and machines and public works vehicles ● Requirements for second stage in the reduction of emissions of gaseous pollutants from vehicles with diesel engines 	Amendments <ul style="list-style-type: none"> > Directive EU 1999/96/EC (entry into force 16/2/2000) ● The title shall be replaced by the following: ‘Council Directive 88/77/EEC of 3 December 1987 on the approximation of the laws of the Member States relating to the measures to be taken against the emission of gaseous and particulate pollutants from compression ignition engines for use in vehicles and the emission of gaseous pollutants from positive ignition engines fuelled with natural gas or liquefied petroleum gas for use in vehicles’ ● Replacement of articles and annexes

(Continued)

Table 4.15 (Continued)

Directive	Title	Main points	Comments
EU 93/12/EEC	The sulfur content of gas oil	<ul style="list-style-type: none"> • Limit values for emissions of gaseous and particulate pollutants from all vehicles • Reduction in sulfur dioxide emissions applies to heavy fuel oils and gas oil • No application to liquid fuels derived from petroleum used by seagoing ships, gas oil for maritime use used by ships crossing a frontier between a third country and a Member State, fuels intended for processing before final combustion, fuels intended for processing in refineries 	<p>Amendments</p> <ul style="list-style-type: none"> > Directive EU 98/70/EC (entry into force 28/12/1998) • Setting of technical specifications on health and environmental grounds for fuels to be used for vehicles equipped with positive-ignition and compression-ignition engines > Directive EU 1999/32/EC (entry into force 11/5/1999) • Amendment of articles
EU 97/68/EC (entry into force 16/12/1987)	The approximation of the laws of the Member States relating to measures against the emission of gaseous and particulate pollutants from internal combustion engines to be installed in non-road mobile machinery	<ul style="list-style-type: none"> • Emission standards and type-approval procedures for engines intended to be fitted to non-road mobile machinery • Manufacturer must affix specific marks to each unit manufactured • A list of the exemptions granted and the reasons given and must guarantee that conformity of production is checked effectively before type approval is granted 	<p>Amendments</p> <ul style="list-style-type: none"> > Directive EU 2001/63/EC • In order to allow for technical progress, it amends Directive EU 97/68/EC in accordance with Regulation (EC) No 96 of the United Nations Economic Commission for Europe (UNECE) on emissions from compression ignition engines to be installed in agricultural and forestry tractors > Directive EU 2002/88/EC • The Directive extends the scope of Directive EU 97/68/EC to also cover small spark ignition (petrol) engines > Directive EU 2004/26/EC • The Directive extends the scope of Directive EU 97/68/EC to cover locomotives and inland waterway vessels
EU 98/70/EC (entry into force 28/12/1998)	The quality of petrol and diesel fuels	<ul style="list-style-type: none"> • Environmental specifications applicable successively to fuels for vehicles equipped with positive ignition engines (petrol) and with compression ignition engines (diesel) • Provides for progressive improvements in the environmental quality of unleaded petrol and diesel fuel • Member States may allow petrol or diesel fuels which fail to comply with the Directive to remain on the market • Member States must monitor using the analytical methods defined 	<p>Amendments</p> <ul style="list-style-type: none"> > Directive EU 2000/71/EC (entry into force 4/12/2000) • Replacement of annexes > Directive EU 2003/17/EC (entry into force 22/3/2003) • The Directive requires Member States to ensure that unleaded petrol and diesel fuel with a maximum sulfur content of 10 mg/kg is marketed within their territories by no later than 1/2/2005. By no later than 1/1/2009 they must ensure that unleaded petrol and diesel fuel marketed in their territory complies with the environmental

(Continued)

Table 4.15 (Continued)

Directive	Title	Main points	Comments
EU 1999/94/EC (entry into force 18/1/2000)	The availability of consumer information on fuel economy and CO ₂ emissions in respect of the marketing of new passenger cars	<ul style="list-style-type: none"> • Fuel economy and CO₂ emissions of new passenger cars offered for sale or lease in the Community • A fuel economy label must be attached to the windshield of all new passenger cars at the point of sale • Member States must notify the Commission of the competent body or bodies responsible for the implementation and functioning of the consumer information scheme 	<p>specifications set out in the Annexes</p> <ul style="list-style-type: none"> > Regulation (EC) No 1882/2003 (entry into force 20/11/2003) • Replacement of annexes <p>Amendments</p> <ul style="list-style-type: none"> > Directive EU 2003/73/EC (entry into force 25/7/2003) • Replacement of annex III > Regulation (EC) No 1882/2003 (entry into force 20/11/2003) • Replacement of annexes
EU 2000/25/EC (entry into force 12/7/2000)	Action to be taken against the emission of gaseous and particulate pollutants by engines intended to power agricultural or forestry tractors	<ul style="list-style-type: none"> • Requirements concerning emissions by agricultural and forestry tractors • Test requirements for off-road mobile machinery and the corresponding limit values for levels of emissions • As of 30/9/2000, Member States may not refuse to grant EC type-approval or national type-approval in respect of an engine type or family, prohibit the sale, refuse to grant EC type-approval or national type-approval of tractor types and prohibit the use 	
COM(2002) 595 Communication from the Commission to the European Parliament and the Council, of 20 November 2002	'A European Union strategy to reduce atmospheric emissions from seagoing ships'	<ul style="list-style-type: none"> • Objectives of strategy are to reduce ships' emissions of SO₂ where they contribute to critical loads for acidification being exceeded and where they affect local air quality, to reduce ships' emissions of NO_x where they contribute to critical loads for acidification and eutrophication being exceeded and buildups of ground-level ozone which affect health and the environment, to reduce ships' emissions of primary particles where these affect local air quality, to reduce ships' emissions of VOCs where these contribute to buildups of ground-level ozone which affect health and the environment, to reduce ships' emissions of CO₂ and to eliminate emissions of ozone-depleting substances from all ships operating in EU waters 	

(Continued)

Table 4.15 (Continued)

Directive	Title	Main points	Comments
Decision No 1753/2000/EC	Establishing a scheme to monitor the average specific emissions of CO ₂ from new passenger cars	<ul style="list-style-type: none"> Community has introduced a strategy to reduce emissions of CO₂ from new passenger cars, setting a target of 120 g/km to be attained by 2005 (2010 at the latest) Member States must collect the vehicle information needed to set up the monitoring scheme 	
Commission working paper of 14 July 1998	Towards a framework for the solution of the environmental problems caused by traffic of heavy goods vehicles	<ul style="list-style-type: none"> Measures are charges for road use, railway infrastructure, combined transport facilities and technical standards for vehicles Commission proposes several specific measures Community's railway policy should promote rail transport or road transport 	

Adapted from Arvanitoyannis *et al.*, 2006b

Air pollution – industry

EU Directive 94/63/EC (entry into force 20/1/1995) shall apply to the operations, installations, vehicles and vessels used for storage, loading and transport of petrol from one terminal to another or from a terminal to a service station. Storage installations shall be designed and operated in accordance with specific technical provisions. These provisions are designed to reduce the total annual loss of petrol resulting from loading and storage at each storage installation at terminals to below the target reference value of 0.01 weight by weight (w/w) % of the throughput. Member States may adopt technical measures for the reduction of losses of petrol other than those set down.

The purpose of EU Directive 96/61/EC (entry into force 30/10/1996) is to achieve integrated prevention and control of pollution arising from the activities. It lays down measures designed to prevent or, where that is not practicable, to reduce emissions in the air, water and land from the abovementioned activities, including measures concerning waste, in order to achieve a high level of protection of the environment taken as a whole. Member States shall take the necessary measures to provide that the competent authorities ensure that installations are operated in such a way that:

- 1 all the appropriate preventive measures are taken against pollution, in particular through application of the best available techniques
- 2 no significant pollution is caused
- 3 waste production is avoided
- 4 energy is used efficiently
- 5 the necessary measures are taken to prevent accidents and limit their consequences

- 6 the necessary measures are taken upon definitive cessation of activities to avoid any pollution risk and return the site of operation to a satisfactory state.

The aim of EU Directive 1999/13/EC (entry into force 29/3/1999) is to prevent or reduce the direct and indirect effects of emissions of volatile organic compounds into the environment, mainly into air, and the potential risks to human health, by providing measures and procedures to be implemented for specific activities, insofar as they are operated above the solvent consumption thresholds listed. Member States shall adopt the necessary measures to ensure that:

- 1 all new installations comply with the provisions
- 2 all new installations not covered by EU Directive 96/61/EC are registered or undergo authorization before being put into operation.

All installations shall comply with:

- 1 either the emission limit values in waste gases and the fugitive emission values, or the total emission limit values, and other requirements laid down or
- 2 the requirements of the reduction scheme specified.

The target of EU Directive 2001/80/EC (entry into force 27/11/2001) is to apply to combustion plants the rated thermal input of which is equal to or greater than 50 W irrespective of the type of fuel used (solid, liquid or gaseous). This Directive shall apply only to combustion plants designed for production of energy with the exception of those which make direct use of the products of combustion in manufacturing processes. Plants powered by diesel, petrol and gas engines shall not be covered by this Directive. The following conditions shall apply to national emission reduction plans:

- 1 the plan shall comprise objectives and related targets, measures and timetables for reaching these objectives and targets, and a monitoring mechanism
- 2 Member States shall communicate their national emission reduction plan to the Commission no later than 27/11/2003
- 3 the Commission shall, no later than 27/11/2002, develop guidelines to assist Member States in the preparation of their plans.

All the EU Directives dealing with air pollution – industry are summarized in Table 4.16.

Water protection and management

The pollutants occurring in municipal wastewaters include solids, microorganisms and the more recently recognized dissolved minerals. Liquid wastes of industries, however, may contain these and many more possible contaminants, such as coloring agents, toxic organic chemicals, heavy metals, oil, detergents, acids and alkalis, odors, heat, radioactivity and many types of colloidal solids. In addition, industrial effluents are

Table 4.16 EU Directives (main points and comments) related to air pollution – industry

Directive	Title	Main points	Comments
EU 94/63/EC (entry into force 20/1/1995)	The control of volatile organic compound (VOC) emissions resulting from the storage of petrol and its distribution from terminals to service stations	<ul style="list-style-type: none"> • Application for the operations, installations, vehicles and vessels used for storage, loading and transport of petrol to a service station • Technical specifications for the design and use of storage installations at terminals, equipment for loading and unloading mobile containers at terminals, mobile containers and equipment for loading into storage installations at service stations are laid down 	Amendment > Regulation (EC) No 1882/2003 (entry into force 20/11/2003) • Replacement of annexes
EU 96/61/EC (entry into force 30/10/1996)	Integrated pollution prevention and control	<ul style="list-style-type: none"> • Issuing and updating operating permits and minimum requirements to be included in any such permit is laid down • Installations can be brought into conformity with the requirements of the Directive 	
EU 1999/13/EC (entry into force 29/3/1999)	The limitation of emissions of volatile organic compounds due to the use of organic solvents in certain activities and installations	<ul style="list-style-type: none"> • Directive covers emissions of organic solvents from stationary commercial and industrial sources • Solvents containing substances likely to have a serious effect on human health, must be replaced by less harmful substances within the shortest possible time • Member States may define and implement national plans for reducing emissions from the activities and industrial installations 	Amendments > Regulation (EC) No 1882/2003 (entry into force 20/11/2003) • Replacement of annexes > Directive EU 2004/42/EC (entry into force 30/4/2004) • Amendment of annexes
EU 2001/80/EC (entry into force 27/11/2001)	The limitation of emissions of certain pollutants into the air from large combustion plants	<ul style="list-style-type: none"> • Directive applies to combustion plants with a rated thermal input equal to or greater than 50 MW • Aiming at reducing the annual emissions of sulfur dioxide and oxides of nitrogen from existing plants and to lay down emission limit values for sulfur dioxide • Significant emission reductions by 1/1/2008 at the latest and implement a national emission reduction plan for existing plants 	

Adapted from Arvanitoyannis *et al.*, 2006b

much more unpredictable as to both quantity and quality at any given time (Nemerow, 1995). Several Directives were adopted by the Member States towards introducing water quality standards: drinking water (EU Directive 98/83/EC), bathing water (EU Directive 76/160/EEC) and water for aquaculture (EU Directive 78/659/EEC).

Community measures in the 1980s and early 1990s were based more on the principle of emission critical limits. The treatment of urban wastewater (EU Directive 91/271/EEC) and measures to reduce pollution from nitrates (EU Directive 91/76/EEC) are examples of this. From 1995, the Community began to adopt a more global approach to water management. This has led to the framework Directive for a policy on water (EU Directive 2000/60/EC) which seeks to promote sustainable use of water resources and to ensure the coherence of policy in this area. The Community is a party to various international conventions aimed at protecting the marine environment: the above-mentioned OSPAR Convention, the Barcelona Convention for the Protection of the Mediterranean Sea (Council Decision 77/585/EEC) and the Paris Convention for the Protection of the Marine Environment of the North East Atlantic. Other conventions seek to protect and preserve water courses: the Helsinki Convention on Transboundary Water Courses and International Lakes, the Convention on Cooperation for the Protection and Sustainable Use of the River Danube, the Convention on the Protection of the Rhine etc. (<http://europa.eu.int/scadplus/leg/en/lvb/l28066.htm>).

Water protection and management – general framework

The object of EU Directive 2000/60/EC (entry into force 22/12/2000) is to establish a framework for the protection of inland surface waters, transitional waters, coastal waters and groundwater which:

- 1 prevents further deterioration and protects and enhances the status of aquatic ecosystems and, with regard to their water needs, terrestrial ecosystems and wetlands directly depending on the aquatic ecosystems
- 2 promotes sustainable water use based on a long-term protection of available water resources
- 3 aims at enhanced protection and improvement of the aquatic environment, inter alia, through specific measures for the progressive reduction of discharges, emissions and losses of priority substances and the cessation or phasing-out of discharges, emissions and losses of the priority hazardous substances
- 4 ensures the progressive reduction of pollution of groundwater and prevents its further pollution
- 5 contributes to mitigating the effects of floods and droughts.

Member States shall identify the individual river basins lying within their national territory and shall assign them to individual river basin districts. Each Member State shall ensure that, for each river basin district or for the portion of an international river basin district falling within its territory:

- 1 there is an analysis of its characteristics
- 2 there is a review of the impact of human activity on the status of surface waters and on groundwater
- 3 an economic analysis of water use is undertaken according to the technical specifications set out.

In the Communication from the Commission to the Council, European Parliament and Economic and Social Committee, entitled 'Pricing and sustainable management of water resources', the Commission stresses that this communication should not be taken as solely advocating pricing in order to solve water-resource problems. However, this must be taken into due consideration and be combined with other instruments as part of drawing up of management plans for water resources at individual catchment-area level. In order to achieve the environmental aims and to include the major economic principles, water pricing policies must reflect the following costs:

- 1 Financial costs: direct costs embracing the costs of supply and administration, operation and maintenance, and also capital costs
- 2 Environmental costs: cost of the waste caused by water use on the ecosystem
- 3 Resource costs: cost of resource depletion leading to the disappearance of certain options for other users.

Decision 2455/2001/EC adopts a list of priority substances including substances identified as priority hazardous substances. In order to ensure consideration of all potential priority substances, the Commission and the Member States shall ensure that the substance and exposure-related data needed for the implementation of the COMMPS procedure are made available.

A summary of the EU Directive, Communication and Decision focused on water protection and management – general framework is given in Table 4.17.

Water protection and management – specific uses of water

EU Directive 98/38/EC (entry into force 25/12/1998) relates to the quality of water intended for human consumption. Its objective is to protect human health from the adverse effects of any contamination of water intended for human consumption by ensuring that it is wholesome and clean. It shall not apply to natural mineral waters and waters which are medicinal products. Member States may exempt from the provisions:

- 1 water intended exclusively for those purposes for which the competent authorities are satisfied that the quality of the water has no influence, either directly or indirectly, on the health of the consumers concerned
- 2 water intended for human consumption from an individual supply providing less than 10 m³ a day as an average or serving fewer than 50 persons, unless the water is supplied as part of a commercial or public activity.

EU Directive 75/440/EEC (entry into force 16/6/1977) concerns the quality requirements which surface freshwater used or intended for use in the abstraction of drinking water must meet after application of appropriate treatment. Surface water shall be divided according to limiting values into three categories, A1, A2 and A3, which correspond to the appropriate standard methods of treatment given. These groups correspond to three different qualities of surface water, the respective physical, chemical

Table 4.17 EU Directive, Communication and Decision (titles, main points and comments) on water protection and management – general framework

Directive	Title	Main points	Comments
EU 2000/60/EC (entry into force 22/12/2000)	Establishment of a framework for Community action in the field of water policy	<ul style="list-style-type: none"> • All the river basins lying within their national territory and assign them to individual river basin districts • Analysis of the characteristics of each river basin district, a review of the impact of human activity on the water, an economic analysis of water use and a register of areas requiring special protection • Nine years after, a management plan and program of measures must be produced for each river basin district • Objectives have to be achieved at the latest fifteen years after the date of entry into force of the Directive 	<p>Amendment</p> <ul style="list-style-type: none"> > Decision No 2455/2001/EC (entry into force 16/12/2001) • Addition of a list of priority substances including substances identified in EU Directive 2000/60/EC <p>Repeals</p> <p>Seven years after the entry into force of the Directive, the following legislation will be repealed:</p> <ul style="list-style-type: none"> > Directive EU 75/440/EEC > Directive EU 77/795/EEC > Directive EU 79/869/EEC <p>Thirteen years after the entry into force of the Directive, the following legislation will be repealed:</p> <ul style="list-style-type: none"> > Directive EU 78/659/EEC > Directive EU 79/923/EEC > Directive EU 80/68/EEC > Directive EU 76/464/EEC, repealed on the date of entry into force of this Directive
Communication from the Commission to the Council, European Parliament and Economic and Social Committee	Pricing and sustainable management of water resources	<ul style="list-style-type: none"> • Aiming to enable a fruitful political debate to take place on this matter and to inform those concerned 	
Decision 2455/2001/EC (entry into force 16/12/2001)	Establishment of the list of priority substances in the field of water policy	<ul style="list-style-type: none"> • Decision ranks in order of priority the substances for which quality standards and emission control measures will be set at Community level • Using a procedure for compiling data produced by a new method • Up to 33 priority substances or groups of substances have been proposed 	

Adapted from Arvanitoyannis *et al.*, 2006c

and microbiological characteristics of which are set out. Member States shall take all necessary measures to ensure that surface water conforms to the values laid down. Surface water shall be assumed to conform to the relevant parameters if samples of this water taken at regular intervals at the same sampling point and used in the

abstraction of drinking water show that it complies with the parametric values for the water quality in question, in the case of:

- 1 95% of the samples for parameters conforming to those specified
- 2 90% of the samples in all other cases.

EU Directive 79/869/EEC (entry into force 9/10/1981) deals with the reference methods of measurement and frequencies of sampling and analysis for the parameters listed. Member States shall, as far as possible, use the reference methods of measurement. The values for the limit of detection and for the precision and accuracy of the methods of measurement used to check the parameters must be respected. The containers used for samples, the agents or methods used to preserve part of a sample for the analysis of one or more parameters, the conveyance and storage of samples and the preparation of samples for analysis must not be such as to bring about any significant change in the results of the analysis.

EU Directive 78/659/EEC (entry into force 20/7/1980) concerns the quality of freshwaters and applies to those waters designated by the Member States as needing protection or improvement in order to support fish life. It shall not apply to waters in natural or artificial fish ponds used for intensive fish-farming. The aim of this Directive is to protect or improve the quality of those running or standing freshwaters which support or which, if pollution were reduced or eliminated, would become capable of supporting fish belonging to indigenous species offering a natural diversity or species the presence of which is judged desirable for water management purposes by the competent authorities of the Member States. Member States shall, for the designated waters, set values for the parameters listed. Member States shall, initially within a two-year period following the notification of this Directive, designate salmonid waters and cyprinid waters.

EU Directive 91/271/EEC (entry into force 19/6/1991) relates to the collection, treatment and discharge of urban wastewater and the treatment and discharge of wastewater from certain industrial sectors. Member States shall ensure that urban wastewater entering collecting systems shall before discharge be subject to secondary treatment or an equivalent treatment. Competent authorities or appropriate bodies shall monitor discharges from urban wastewater treatment plants to verify compliance with the requirements in accordance with the control procedures laid down and amounts and composition of sludges disposed of to surface waters.

Some representative points and comments (repeals, amendments) of the EU Directives with regard to water protection and management – specific uses of water are given in Table 4.18.

Water protection and management – marine pollution

The object of Regulation (EC) No 782/2003 (entry into force 10/5/2003) is to reduce or eliminate adverse effects on the marine environment and human health caused by organotin compounds, which act as active biocides in anti-fouling systems used on ships flying the flag of, or operating under the authority of, a Member State, and on

Table 4.18 EU Directives (main points and comments) related to water protection and management – specific uses of water

Directive	Title	Main points	Comments
EU 98/38/EC (entry into force 25/12/1998)	The quality of water intended for human consumption	<ul style="list-style-type: none"> • Application for all water intended for human consumption apart from natural mineral waters and waters which are medicinal products • Drinking water does not contain any concentration of microorganisms, parasites or any other substance which constitutes a potential human health risk • Member States shall take any action needed in order to guarantee that water quality complies with the provisions 	<p>Repeal</p> <ul style="list-style-type: none"> > Directive EU 80/778/EEC shall be repealed and replaced by Directive EU 98/83/EC with effect from 25/12/2003
EU 75/440/EEC (entry into force 16/6/1977)	The quality required of surface water intended for the abstraction of drinking water in the Member States	<ul style="list-style-type: none"> • Setting of the minimum quality requirements to be met by surface freshwater • Parameters and the frequency of analysis of surface water in accordance with the guidelines set out in the Directives • Surface water is classified on the basis of its characteristics into three categories with different limit values • Procedure for adapting to technical progress the reference methods of measurement, the limit of detection, and the precision and accuracy of these methods 	<p>Amendments</p> <ul style="list-style-type: none"> > Directive EU 79/869/EEC (entry into force 9/10/1981) • It concerns the reference methods of measurement and frequencies of sampling and analysis for the parameters listed in Annex II to EU Directive 75/440/EEC > Directive EU 91/692/EEC (entry into force 1/1/1993) • Replacement of specific provisions of annexes
EU 79/869/EEC (entry into force 9/10/1981)	The methods of measurement and frequencies of sampling and analysis of surface water intended for the abstraction of drinking water in the Member States	<ul style="list-style-type: none"> • Establishment of reference methods of measurement frequencies of sampling and analysis for the parameters listed and which define the physical, chemical and microbiological characteristics of surface water intended for the abstraction of drinking water 	<p>Amendments</p> <ul style="list-style-type: none"> > Directive EU 81/855/EEC (entry into force 1/1/1981) • Replacement of an article > Directive EU 90/656/EEC (entry into force 31/12/1995) • Amendments of the annexes > Directive EU 91/692/EEC (entry into force 1/1/1993) • Replacement of specific provisions of annexes
EU 78/659/EEC (entry into force 20/7/1980)	The quality of freshwaters needing protection or improvement in order to support fish life	<ul style="list-style-type: none"> • Directive concerns the protection and/or improvement of the quality of running or standing freshwaters • Waters in natural or artificial fish ponds used for intensive fish-farming are excluded • To designate the freshwaters which are to be considered suitable for fish-breeding • Minimum quality criteria to be met by such waters are laid down • Procedure for adapting the methods of analysis and the binding limit values to technical and scientific progress 	<p>Amendments</p> <ul style="list-style-type: none"> > Directive EU 91/692/EEC (entry into force 1/1/1993) • Replacement of specific provisions of annexes > Regulation (EC) No 807/2003 (entry into force 5/6/2003) • Replacement of annexes <p>Repeal</p> <ul style="list-style-type: none"> > The Framework Directive in the field of water policy provides for the Directive to be repealed on 22/12/2013

(Continued)

Table 4.18 (Continued)

Directive	Title	Main points	Comments
EU 91/271/EEC (entry into force 19/6/1991)	Urban wastewater treatment	<ul style="list-style-type: none"> ● Directive concerns the collection, treatment and discharge of urban wastewater and the treatment and discharge of wastewater from certain industrial sectors ● Industrial wastewater entering collecting systems and the disposal of wastewater and sludge from urban wastewater treatment plants ● Specific requirements for discharges from certain industrial sectors of biodegradable industrial wastewater not entering urban wastewater treatment plants 	Amendment > Directive EU 98/15/EC (entry into force 27/3/1998) ● Amendment of annex I

Adapted from Arvanitoyannis *et al.*, 2006c

ships, regardless of the flag they fly, sailing to or from ports of the Member States. This Regulation shall apply to:

- 1 ships flying the flag of a Member State
- 2 ships not flying the flag of a Member State but operating under the authority of a Member State
- 3 ships that enter a port or offshore terminal of a Member State but do not fall within points (1) or (2). As from 1/7/2003, organotin compounds which act as biocides in anti-fouling systems shall not be applied or re-applied on ships.

The Proposal for a Regulation of the European Parliament and of the Council on the establishment of a fund for the compensation of oil pollution damage in European waters and related measures (COM(2000) 802 final – Official Journal C 120 E, 24 April 2001) forms part of the second package of Community measures on maritime safety. The objective of this proposal from the Commission is to set up a supplementary fund covering liability and compensation for pollution damage caused by oil tankers, designated COPE (Compensation for Oil Pollution in European waters fund), to pay compensation to the victims of oil spills in European waters. Moreover, this proposal aims at ensuring adequate compensation for pollution damage in EU waters resulting from the transport of oil by sea and to introduce a financial penalty to be imposed on any person found to have contributed to an oil pollution incident.

Communication from the Commission to the Council and the European Parliament of 2 October 2002, 'Towards a strategy to protect and conserve the marine environment' (COM(2002) 539 final – not published in the Official Journal) starts by taking stock of the environmental quality of the seas and oceans, particularly off Europe's coasts, giving both a summary and a more extensive description of the situation.

These threats include loss or degradation of biodiversity, changes in the structure of the ecosystem, loss of habitats, contamination by dangerous substances and nutrients and the potential consequences of climate change. The related pressures include commercial fishing, oil and gas exploration, shipping, water-borne and atmospheric deposition of hazardous substances and nutrients, waste dumping and physical degradation of habitats due to dredging and extraction of sand and gravel.

The Proposal for a Directive of the European Parliament and of the Council on ship-source pollution and on the introduction of sanctions, including criminal sanctions, for pollution offences (COM(2003) 92 final – not published in the Official Journal) consists of two different measures:

- 1 the incorporation into Community law of international discharge rules for ship-source pollution and detailed regulation of the enforcement of those rules
- 2 the establishment of criminal sanctions and guidance on the nature of the sanctions to be imposed.

It applies to discharges of polluting substances in:

- 1 the internal waters, including ports, of a Member State
- 2 the territorial sea of a Member State
- 3 straits used for international navigation subject to the regime of transit passage, as laid down in the 1982 United Nations Convention on the Law of the Sea
- 4 the exclusive economic zone (EEZ) of a Member State
- 5 the high seas.

It applies to illegal discharges from any ship, irrespective of its flag, with the exception of any warship or other ship owned or operated by a State and used only on government non-commercial service.

Decision 77/585/EEC (entry into force 25/7/1977) covers only pollution of the region of the Mediterranean Sea caused by ships and aircraft (I).

Decision 81/420/EEC (entry into force 19/5/1981) stipulates that the Parties will cooperate when a huge quantity of oil and/or other harmful substances in the Mediterranean Sea, whether accidental or cumulative, presents a serious and imminent danger to the marine environment, the coast or the economic, health or ecological interests of one or more Parties (II).

The purpose of Decision 83/101/EEC (entry into force 28/2/1983) is to fight pollution in the Mediterranean Sea caused by discharges from rivers, outfalls, canals or other watercourses, or pollution emanating from any other source or activity within the territory of the States party to the Protocol (III).

Decision 84/132/EEC (entry into force 1/3/1984) concerning specially protected areas in the Mediterranean, to which the Community acceded in 1984, protects natural resources in the Mediterranean region, preserves the diversity of the gene pool and protects certain natural sites by creating a series of specially preserved areas (IV).

Following Decision 1999/800/EC (entry into force 22/10/1999), the contracting parties to the Convention will individually or jointly take all appropriate measures to

prevent, abate and combat pollution of the Mediterranean Sea area. The parties give particular attention to four types of pollution:

- 1 due to dumping from ships and aircraft
- 2 pollution from ships
- 3 due to exploration and exploitation of the continental shelf and the seabed and its subsoil
- 4 due to land-based sources (V).

Furthermore, Decision 1999/801/EC (entry into force 22/10/1999) updates the legal mechanisms in the Barcelona Convention by incorporating in it measures concerning cooperation between Parties regarding prevention and, in cases of emergency, combating pollution in the Mediterranean caused by ships. It also endeavors to promote the development and implementation of international regulations adopted in the framework of the International Maritime Organization (VI).

Finally, Decision 1999/802/EC (entry into force 22/10/1999) regards the acceptance of amendments to the Convention for the Protection of the Mediterranean Sea against Pollution and to the Protocol for the Prevention of Pollution by Dumping from Ships and Aircraft (Barcelona Convention) (VII) and Decision 2004/575/EC (entry into force 29/4/2004) regards the conclusion, on behalf of the European Community, of the Protocol to the Barcelona Convention for the Protection of the Mediterranean Sea against Pollution, concerning cooperation in preventing pollution from ships and, in cases of emergency, combating pollution of the Mediterranean Sea (VIII).

Decision 94/156/EC and Decision 94/157/EC: the Parties to the Convention undertake to ban the use of dichlorodiphenyltrichloroethane (DDT) and its derivatives (DDE and DDD), polychlorinated biphenyls (PCBs) and polychlorinated terphenyls (PCTs) in the Baltic Sea area. They must also take all appropriate measures and work together to control and minimize pollution from land-based sources. Large quantities of the substances referred to may not be introduced without a prior special permit issued by the appropriate national authority. With regard to pollution from ships, the Parties must take a series of measures to protect the Baltic Sea area against pollution linked to spillage of hydrocarbons and other harmful substances and the discharge of wastewater and sewage from ships. The Contracting Parties must ban the dumping of waste in the Baltic Sea area, except for:

- 1 dredged material, provided a special permit has been issued
- 2 cases where the safety of human life or of a ship or aircraft at sea is threatened by the complete destruction or total loss of the ship or aircraft, if dumping appears to be the only way of averting the threat.

Decision 98/249/EC (entry into force 23/4/1998): the Parties to the Convention undertake to take all possible steps to prevent and eliminate pollution and the necessary measures to protect the maritime area against the adverse effects of human activities so as to safeguard human health and to conserve maritime ecosystems and, when practicable, restore marine areas which have been adversely affected. To this end, the

Parties will, individually and jointly, adopt programs and measures and harmonize their policies and strategies. The Parties to the Convention, individually or jointly, take all possible steps:

- 1 to prevent and eliminate pollution of the maritime area from land-based sources
- 2 to prevent and eliminate pollution by dumping or incineration of wastes or other matter
- 3 to prevent and eliminate pollution from offshore sources.

According to Decision No 2850/2000/EC, the Member States are obliged to improve Community action in the field of accidental marine pollution and integrate it into a single framework for cooperation covering the period from 1/1/2000 to 31/12/2006. The framework for cooperation is intended to:

- 1 supplement Member States' efforts at national, regional and local level to protect the marine environment, human health and coastlines against the risks of accidental or deliberate pollution at sea
- 2 reinforce cooperation and mutual assistance between the Member States in this field, with a view to providing for compensation for damage in accordance with the polluter-pays principle
- 3 improve the response capabilities of the Member States in the event of incidents involving spills of harmful substances at sea.

The plan will specify individual actions, which will be selected on the basis of their contribution to:

- 1 informing and preparing those responsible for and involved in dealing with accidental marine pollution in the Member States, including port authorities
- 2 improving the techniques and methods of intervention and rehabilitation after emergencies and techniques for assessing damage
- 3 providing operational support, by mobilizing experts from the Community Task Force to the Member States
- 4 better public information and stepping up cooperation with the competent local authorities and with nature protection organizations.

In Decision 2002/762/EC, the Bunkers Convention filled a significant gap in the international regulations on marine pollution liability. The Convention applies to pollution damage caused in the territory, in the territorial sea and in the exclusive economic zone or equivalent zone of any State which is a party to the Convention and measures taken to prevent or minimize such damage. The shipowner at the time of an incident is liable for all pollution damage caused by its bunker oil. However, no liability will attach to the shipowner if the shipowner proves that:

- 1 the damage resulted from an act of war, hostilities, insurrection or a natural phenomenon of an exceptional, inevitable and irresistible character
- 2 the damage was caused by an act or omission done with intent to cause damage by a third party

3 the damage was wholly caused by the negligence of any Government or other authority responsible.

The titles, main points and comments of the EU Regulation, Proposals for Regulation, Communication and Decisions about water protection and management – marine pollution are summarized in Table 4.19.

Table 4.19 EU Regulation, Proposals for Regulation, Communication and Decisions (titles, main points and comments) for water protection and management – marine pollution

Directive	Title	Main points	Comments
Regulation (EC) No 782/2003 (entry into force 10/5/2003)	The prohibition of organotin compounds on ships	<ul style="list-style-type: none"> • Regulation imposes on shipowners detailed requirements • No application for any warship, naval auxiliary or other ship owned by a State and used on government service • As from 1/7/2003, organotin compounds may no longer be applied on ships flying the flag of a Member State 	
COM(2000) 802 final Official Journal C 120 E, 24 April 2001	Proposal for a Regulation of the European Parliament and of the Council on the establishment of a fund for the compensation of oil pollution damage in European waters and related measures	<ul style="list-style-type: none"> • To ensure adequate compensation for pollution damage in EU waters resulting from the transport of oil by sea and to introduce a financial penalty on any person found to have contributed to an oil pollution incident 	Codecision procedure (COD/2002/0326) On 12/6/2002 the Commission adopted an amended proposal On 12/6/2002 the amended proposal was submitted to the European Parliament
COM(2002) 539 final Not published in the Official Journal	Communication from the Commission to the Council and the European Parliament of 2 October 2002 'Towards a strategy to protect and conserve the marine environment'	<ul style="list-style-type: none"> • A set of objectives to promote sustainable use of the seas and conserving marine ecosystems 	
COM(2003) 92 final Not published in the Official Journal	Proposal for a Directive of the European Parliament and of the Council on ship-source pollution and on the introduction of sanctions, including criminal sanctions, for pollution offences	<ul style="list-style-type: none"> • Proposed Directive consists of two different measures: the incorporation into Community law of international discharge rules for ship-source pollution and detailed regulation of the enforcement of those rules and the establishment of criminal sanctions and guidance on the nature of the sanctions to be imposed • Application for discharges of polluting substances in the internal waters of a Member State, the territorial sea of a Member State, straits used for international navigation, the EEZ of a Member State and the high seas 	
Decision 77/585/EEC (entry into force 25/7/1977)	The Convention for the protection of the Mediterranean Sea against pollution and the Protocol for the prevention of the	<ul style="list-style-type: none"> • Protocol covers only pollution of the region of the Mediterranean Sea caused by ships and aircraft • Protocol stipulates that the Parties will cooperate when a huge quantity of oil and/or other harmful substances in the Mediterranean 	

(Continued)

Table 4.19 (Continued)

Directive	Title	Main points	Comments
Decision 81/420/EEC (entry into force 19/5/1981)	pollution of the Mediterranean Sea by dumping from ships and aircraft The conclusion of the Protocol concerning cooperation in combating pollution of the Mediterranean Sea by oil and other harmful substances in cases of emergency	Sea, whether accidental or cumulative, presents a serious and imminent danger to the marine environment, the coast or the economic, health or ecological interests of one or more Parties	
Decision 83/101/EEC (entry into force 28/2/1983)	The Protocol for the protection of the Mediterranean Sea against pollution from land-based sources	<ul style="list-style-type: none"> • Purpose of this Protocol is to combat pollution in the Mediterranean Sea caused by discharges from rivers, outfalls, canals or other watercourses, or pollution emanating from any other source or activity within the territory of the States party to the Protocol • Protocol concerning specially protected areas in the Mediterranean, to which the Community acceded in 1984, protects natural resources in the Mediterranean region, preserves the diversity of the gene pool and protects certain natural sites by creating a series of specially preserved areas 	
Decision 84/132/EEC (entry into force 1/3/1984)	The conclusion of the Protocol concerning Mediterranean specially protected areas	<ul style="list-style-type: none"> • Contracting parties to the Convention will individually or jointly take all appropriate measures to prevent, abate and combat pollution of the Mediterranean Sea area. The parties give particular attention to four types of pollution: (a) pollution caused by dumping from ships and aircraft, (b) pollution from ships, (c) pollution resulting from exploration and exploitation of the continental shelf and the seabed and its subsoil and (d) pollution from land-based sources 	
Decision 1999/800/EC (entry into force 22/10/1999)	The Protocol concerning specially protected areas and biological diversity in the Mediterranean and on accepting the annexes to that Protocol (Barcelona Convention)	<ul style="list-style-type: none"> • Protocol updates the legal mechanisms in the Barcelona Convention by incorporating in it measures concerning cooperation between Parties regarding prevention and, in cases of emergency, combating pollution in the Mediterranean caused by ships. It also endeavors to promote the development and implementation of international regulations adopted in the framework of the International Maritime Organization 	
Decision 1999/801/EC (entry into force 22/10/1999)	Acceptance of the amendments to the Protocol for the protection of the Mediterranean Sea against pollution from land-based sources (Barcelona Convention)		
Decision 1999/802/EC (entry into force 22/10/1999)	The acceptance of amendments to the Convention for the Protection of the Mediterranean Sea against Pollution and to the Protocol for the Prevention of Pollution by Dumping from Ships and Aircraft (Barcelona Convention)		
Decision 2004/575/EC (entry into force 29/4/2004)	The conclusion, on behalf of the European Community, of the Protocol to the Barcelona Convention for the Protection of the		

(Continued)

Table 4.19 (Continued)

Directive	Title	Main points	Comments
	Mediterranean Sea against Pollution, concerning cooperation in preventing pollution from ships and, in cases of emergency, combating pollution of the Mediterranean Sea		
Decision 94/156/EC Official Journal L 73, 16/3/1994	The accession of the Community to the Convention on the Protection of the Marine Environment of the Baltic Sea Area 1974 (Helsinki Convention)	<ul style="list-style-type: none"> Contracting Parties must ban the dumping of waste in the Baltic Sea area with exceptions Each Contracting Party must take the necessary measures to prevent pollution resulting from exploration or exploitation of the seabed or the subsoil thereof Signatories must adopt measures and cooperate to minimize pollution by hydrocarbons and other harmful substances 	
Decision 94/157/EC Official Journal L 73, 16/3/1994	The conclusion, on behalf of the Community, of the Convention on the Protection of the Marine Environment of the Baltic Sea Area (Helsinki Convention as revised in 1992)		
Decision 98/249/EC (entry into force 23/4/1998)	The conclusion of the Convention for the protection of the marine environment of the North-East Atlantic (Paris Convention)	<ul style="list-style-type: none"> Parties to the Convention take all possible steps to prevent and eliminate: (a) pollution of the maritime area from land-based sources, (b) pollution by dumping or incineration of wastes or other matter and (c) pollution from offshore sources Arbitration procedure is laid down for the settlement of disputes between Contracting Parties 	Replacement > The Convention entered into force on 23/4/1998 to replace the Oslo (1972) and Paris (1974) Conventions
Decision No 2850/2000/EC (entry into force 28/12/2000)	Setting up a Community framework for cooperation in the field of accidental or deliberate marine pollution	<ul style="list-style-type: none"> Decision is designed to improve Community action in the field of accidental marine pollution and integrate it into a single framework for cooperation covering the period from 1/1/2000 to 31/12/2006 Framework for cooperation will be implemented on the basis of a 3 year rolling action plan, to be re-examined annually 	
Decision 2002/762/EC Official Journal L 256 of 25/9/2002	Authorization of the Member States, in the interest of the Community, to sign, ratify or accede to the International Convention on Civil Liability for Bunker Oil Pollution Damage, 2001 (the Bunkers Convention)	<ul style="list-style-type: none"> Convention applies to: (a) pollution damage caused in the territory, in the territorial sea and in the exclusive economic zone or equivalent zone of any State which is a party to the Convention and (b) measures taken to prevent or minimize such damage Shipowner at the time of an incident is liable for all pollution damage caused by its bunker oil 	

Adapted from Arvanitoyannis *et al.*, 2006c

Water protection and management – inland water

The Danube and the Black Sea constitute the largest non-oceanic body of water in Europe. As the environmental situation in the region is extremely critical, a strategy is required to rectify it. If this strategy is to be effective, there has to be cooperation between all the countries of the region. The Communication from the Commission, entitled 'Environmental cooperation in the Danube – Black Sea region (COM(2001) 615 final – not published in the Official Journal) is the current instrument for environmental cooperation. The Communication considers that it should be reinforced and form the basis for environmental cooperation in the region. Discharge of wastewater, oil pollution in the coastal areas and loss of biodiversity, including fish stocks, are the most serious problems in the Black Sea. The Commission states that the long-term goal is to reduce the levels of nutrients and other hazardous substances in the water in order to allow the ecosystems to recover. The intermediate goal is to implement measures to avoid discharges of nitrogen and phosphorus to the Black Sea exceeding 1997 levels by promoting sustainable water use, reducing pollution of groundwater and mitigating the effects of floods and droughts.

Decision 95/308/EC (entry into force 4/9/1995) establishes a framework for cooperation between the member countries of the United Nations Economic Commission for Europe on the prevention and control of pollution of transboundary watercourses by ensuring rational use of water resources with a view to sustainable development. The Parties to the Convention undertake to take all appropriate measures to prevent, control and reduce any transboundary impact. This means they must:

- 1 ensure that transboundary waters are managed in a rational, environment-friendly manner
- 2 ensure that transboundary waters are used in a reasonable and equitable way
- 3 ensure conservation and restoration of ecosystems.

The new Convention for the Protection of the Rhine on behalf of the Community was approved by Decision 2000/706/EC. The aims of the new Convention are as follows:

- 1 sustainable development of the Rhine ecosystem
- 2 production of drinking water
- 3 improvement of sediment quality
- 4 flood protection
- 5 coordination with measures to protect the North Sea.

All the EU Communication and Decisions with regard to water protection and management – inland water are given in Table 4.20.

Water protection and management – discharges of substances

EU Directive 76/464/EEC (entry into force 5/5/1976) applies to inland surface water, territorial waters, internal coastal waters and groundwater. Member States shall apply a system of zero-emission to discharges into groundwater of specific substances. The Council shall lay down the limit values which the emission standards must not exceed

Table 4.20 EU Communication and Decisions (main points and comments) dealing with water protection and management – inland water

Directive	Title	Main points
COM(2001) 615 final Not published in the Official Journal	Communication from the Commission: Environmental cooperation in the Danube – Black Sea region	<ul style="list-style-type: none"> • Convention on cooperation and protection and sustainable use of the Danube River and the Convention on the protection of the Black Sea against pollution • Commission states that the long-term goal is to reduce the levels of nutrients and other hazardous substances in the water • Intermediate goal is to implement measures to avoid discharges of nitrogen and phosphorus to the Black Sea exceeding 1997 levels
Decision 95/308/EC (entry into force 4/9/1995) Official Journal L 186 of 5/8/1995	The conclusion, on behalf of the Community, of the Convention on the protection and use of transboundary watercourses and international lakes (Helsinki Convention)	<ul style="list-style-type: none"> • Cooperation between the member countries of the United Nations Economic Commission for Europe on the prevention and control of pollution of transboundary watercourses by ensuring rational use of water resources with a view to sustainable development • Cooperation among the Riparian Parties by means of bilateral and multilateral agreements for the introduction of harmonized policies, programs and strategies to protect transboundary waters
Decision 2000/706/EC	The conclusion, on behalf of the Community, of the Convention for the Protection of the Rhine	<ul style="list-style-type: none"> • Decision approves the new Convention for the Protection of the Rhine on behalf of the Community • Aiming at sustainable development of the Rhine ecosystem, production of drinking water, improvement of sediment quality, flood protection and coordination with measures to protect the North Sea

Adapted from Arvanitoyannis *et al.*, 2006c

for the various dangerous substances included in the families and groups of substances laid down. These limit values shall be determined by:

- 1 the maximum concentration of a substance permissible in a discharge
- 2 where appropriate, the maximum quantity of such a substance expressed as a unit of weight of the pollutant per unit of the characteristic element of the polluting activity. The limit values applicable to the substances shall be laid down mainly on the basis of: toxicity, persistence and bioaccumulation.

The aim of EU Directive 80/68/EEC (entry into force 19/12/1981) was to prevent the pollution of groundwater by substances belonging to specific families and groups of substances laid down in the Annexes (List I, List II). This Directive should not apply to:

- 1 discharges of domestic effluents from isolated dwellings not connected to a sewerage system and situated outside areas protected for the abstraction of water for human consumption

- 2 discharges which are found by the competent authority of the Member State concerned to contain substances in lists I or II in a quantity and concentration so small as to obviate any present or future danger of deterioration in the quality of the receiving groundwater
- 3 discharges of matter containing radioactive substances.

Member States shall take the necessary steps to:

- 1 prevent the introduction into groundwater of substances in list I
- 2 limit the introduction into groundwater of substances in list II so as to avoid pollution of this water by these substances.

EU Directive 82/176/EEC (entry into force 1/7/1983) laid down the following:

- 1 limit values for emission standards for mercury in discharges from industrial plants
- 2 quality objectives for mercury in the aquatic environment
- 3 the time limits for compliance with the conditions of the authorizations granted by the competent authorities of Member States in the case of existing discharges
- 4 the reference methods of measurement enabling the mercury content in discharges and in the aquatic environment to be determined
- 5 a monitoring procedure
- 6 Member States to cooperate with one another in the case of discharges affecting the waters of more than one Member State.

The objective of EU Directive 91/676/EEC (entry into force 19/12/1991) was to reduce water pollution caused or induced by nitrates from agricultural sources and preventing further such pollution. Member States shall, within a two-year period following the notification of this Directive, designate as vulnerable zones all known areas of land in their territories which drain into the waters identified and which contribute to pollution. With the aim of providing a general level of protection against pollution for all waters, Member States were obliged to, within a two-year period following the notification of this Directive:

- 1 establish a code or codes of good agricultural practice, to be implemented by farmers on a voluntary basis
- 2 set up where necessary a program, including the provision of training and information for farmers, promoting the application of the code(s) of good agricultural practice. They shall also within two years of notification of the Directive, monitor the nitrate concentration in freshwaters over a period of one year, repeat the monitoring program at least every four years and review the eutrophic state of their fresh surface waters, estuarial and coastal waters every four years.

The purpose of EU Directive 96/61/EC (entry into force 30/10/1996) was to achieve integrated prevention and control of pollution arising from the activities laid down. It lays down measures designed to prevent or, where that is not practicable, to reduce

emissions in the air, water and land from specific activities, including measures concerning waste, in order to achieve a high level of protection of the environment taken as a whole. Member States shall take the necessary measures to provide that the competent authorities ensure that installations are operated in such a way that:

- 1 all the appropriate preventive measures are taken against pollution, in particular through application of the best available techniques
- 2 no significant pollution is caused
- 3 waste production is avoided
- 4 energy is used efficiently
- 5 the necessary measures are taken to prevent accidents and limit their consequences
- 6 the necessary measures are taken upon definitive cessation of activities to avoid any pollution risk and return the site of operation to a satisfactory state.

Regulation (EC) No 648/2004 (entry into force 8/10/2005) establishes rules designed to achieve the free movement of detergents and surfactants for detergents in the internal market while, at the same time, ensuring a high degree of protection of the environment and human health. It harmonizes the following rules for the placing on the market of detergents and of surfactants for detergents:

- 1 the biodegradability of surfactants in detergents
- 2 restrictions or bans on surfactants on grounds of biodegradability
- 3 the additional labeling of detergents, including fragrance allergens
- 4 the information that manufacturers must hold at the disposal of the Member States competent authorities and medical personnel. The request by a manufacturer for derogation shall be made by sending an application to the competent authority of the Member State concerned.

Some representative points and comments (repeals, modifications, amendments) of EU Directives and Regulation (main points and comments) related to water protection and management – discharges of substances are given in Table 4.21.

Protection of nature and biodiversity

The starting point for environmental protection is a good condition of the environment and ecologically sustainable development. Land and water use, construction and housing all have an impact on the environment. Environmental protection seeks to prevent and reduce adverse environmental impacts caused by human activity and to improve the state of the environment thus preserving architectural and cultural heritage. Nature conservation is aimed at maintaining natural biodiversity. The latter implies the variety and abundance of types of plants, animals and other organisms, their genetic variation and the variety of different habitats. Nature conservation areas and national parks give people the opportunity to enjoy nature (http://www.suomi.fi/english/nature_and_the_environment/environmental_protection_and_nature_conservation/).

Table 4.21 EU Directives and Regulation (main points and comments) related to water protection and management – discharges of substances

Directive	Title	Main points	Comments
EU 76/464/EEC (entry into force 5/5/1976)	Pollution caused by certain dangerous substances discharged into the aquatic environment of the Community	<ul style="list-style-type: none"> • Application for inland surface water, territorial waters, internal coastal waters and groundwater • To eliminate pollution of these waters, two lists of dangerous substances to be monitored are established 	Amendment > Directive EU 91/692/EEC (entry into force 1/1/1993) • Replacement of specific provisions of annexes
EU 80/68/EEC (entry into force 19/12/1981)	The protection of groundwater against pollution caused by certain dangerous substances	<ul style="list-style-type: none"> • Prevention of discharge of certain toxic, persistent and bioaccumable substances into groundwater • Discharges of domestic effluents from isolated dwellings and discharges of matter containing radioactive substances 	Amendment > Directive EU 91/692/EEC (entry into force 1/1/1993) • Replacement of specific provisions of annexes
EU 82/176/EEC (entry into force 1/7/1983)	Limit values and quality objectives for mercury discharges by the chlor-alkali electrolysis industry	<ul style="list-style-type: none"> • Directive concerns inland surface water, territorial waters and internal coastal waters • Lays down for plant in which alkali chlorides are electrolyzed by means of mercury cells 	Amendment > Directive EU 91/692/EEC (entry into force 1/1/1993) • Replacement of specific provisions of annexes
EU 91/676/EEC (entry into force 19/12/1991)	The protection of waters against pollution caused by nitrates from agricultural sources	<ul style="list-style-type: none"> • Member States must identify, on their territory surface waters and groundwater affected or which could be affected by pollution, in accordance with the procedure and criteria set out in the Directive • Member States must establish codes of good agricultural practice to be implemented by farmers on a voluntary basis 	Amendment > Regulation (EC) No 1882/2003 (entry into force 20/11/1993) • Amendment of annexes
EU 96/61/EC (entry into force 30/10/1996)	Integrated pollution prevention and control	<ul style="list-style-type: none"> • Directive defines the basic obligations to be met by all the industrial installations concerned, whether new or existing • Transitional period (30/10/1999–30/10/2007) is laid down during which existing installations can be brought into conformity with the requirements 	
Regulation (EC) No 648/2004 (entry into force 8/10/2005)	Detergents	<ul style="list-style-type: none"> • Protection of the aquatic environment against the surfactants in detergents and other cleaning products • Regulation stipulates that the Commission shall conduct an evaluation and submit a report and a legislative proposal on the use of phosphates with a view to gradually introducing a ban or restrictions on the use of such products • By 8/4/2007 at the latest, the Commission will similarly conduct an evaluation and submit a report and a legislative proposal on anaerobic biodegradability 	Repeals > Directive EU 73/404/EEC > Directive EU 73/405/EEC > Directive EU 82/242/EEC > Directive EU 82/243/EEC > Directive EU 86/94/EEC (on the biodegradability of surfactant detergents) > Commission Recommendation 89/542 on the labeling of detergents

Adapted from Arvanitoyannis *et al.*, 2006c

International obligations on nature protection are entered into at federal level. Among the conventions on the environment, the most important ones on biodiversity conservation are:

- 1 the Ramsar Convention on Wetlands of International Importance Especially as Waterfowl Habitat (1971), ratified in 1977
- 2 the Convention on Biological Diversity (1992), ratified in 2002
- 3 the Convention on International Trade in Endangered Species of Wild Fauna and Flora (1979) (CITES), ratified in 2002 (http://www.unece.org/env/epr/studies/serbia_and_montenegro/chapter09.pdf).

As early as 1971, with the signing of the Convention on Wetlands of International Importance Especially as Waterfowl Habitat (commonly called the Ramsar Convention), the international community recognized the need for 'conservation and wise use' of wetlands which were recognized as valuable natural resources. The Convention on International Trade in Endangered Species of Wild Fauna and Flora (CITES) sought to protect wildlife and plant populations from over-exploitation caused by increased international commercial trade. In fact since 1975, the treaty continues to provide for the monitoring and regulation of trade in designated species in its 135 country members. More recently, at the Rio de Janeiro Earth Summit in 1992, 157 countries signed the Convention on Biological Diversity (CBD), in recognition of the continued threat to global and local biological resources. Notwithstanding a wide range of successful international initiatives and domestic policy measures, biological diversity and natural habitats continue to face increasing pressures primarily from intensive agriculture, forestry, urbanization, fisheries, resource extraction, transport and tourism. At European level, the European Environment Agency (EEA) has found that 'the threat to Europe's wild species continues to be severe and the number of species in decline is growing' (<http://www.rec.org/REC/Progrms/SofiaInitiatives/EcoInstruments/GreenBudget/GreemBudget5/editorial.html>).

Protection of nature and biodiversity – biodiversity

The EU Directive 92/43/EEC (entry into force 10/6/1992) specified that for the purpose of this Directive:

- 1 conservation means a series of measures required to maintain or restore the natural habitats and the populations of species of wild fauna and flora at a favorable status
- 2 natural habitats means terrestrial or aquatic areas distinguished by geographic, abiotic and biotic features, whether entirely natural or semi-natural
- 3 natural habitat types of Community interest includes those which, within the territory referred to in this Directive, are in danger of disappearance in their natural range.

The aim of this Directive was to contribute towards ensuring biodiversity through the conservation of natural habitats and of wild fauna and flora in the European territory of the Member States to which the Treaty applies. Member States shall take the

requisite measures to establish a system of strict protection for the animal species in their natural range, prohibiting:

- 1 all forms of deliberate capture or killing of specimens of these species in the wild
- 2 deliberate disturbance of these species, particularly during the period of breeding, rearing, hibernation and migration
- 3 deliberate destruction or taking of eggs from the wild
- 4 deterioration or destruction of breeding sites or resting places.

According to the Decision 82/72/EEC (entry into force 1/9/1982), the European Community is a contracting party to the Convention on the conservation of European wildlife and natural habitats adopted at Bern on 19 September 1979. Wild flora and fauna constitute a natural heritage of great value that needs to be preserved and handed on to future generations. In addition to national protection programs, the parties to the Convention consider that cooperation should be established at a European level. The parties undertook to:

- 1 promote national policies for the conservation of wild flora, wild fauna and natural habitats
- 2 integrate the conservation of wild flora and fauna into national planning, development and environmental policies
- 3 promote education and disseminate information on the need to conserve species of wild flora and fauna and their habitats.

Appropriate legislative and administrative measures must also be adopted to conserve the wild fauna species. The following were prohibited:

- 1 all forms of deliberate capture and keeping and deliberate killing
- 2 the deliberate damage to or destruction of breeding or resting sites
- 3 the deliberate disturbance of wild fauna, particularly during the period of breeding, rearing and hibernation
- 4 the deliberate destruction or taking of eggs from the wild or keeping these eggs
- 5 the possession of and internal trade in these animals, alive or dead, including stuffed animals and any part or derivative thereof.

The objectives of Decision 93/626/EEC (entry into force 25/10/1993), to be pursued in accordance with its relevant provisions, are the conservation of biological diversity, the sustainable use of its components and the fair and equitable sharing of the benefits arising out of the utilization of genetic resources, including by appropriate access to genetic resources and by appropriate transfer of relevant technologies, taking into account all rights over those resources and to technologies, and by appropriate funding. Each Contracting Party shall, as far as possible and as appropriate:

- 1 establish a system of protected areas or areas where special measures need to be taken to conserve biological diversity

- 2 develop guidelines for the selection, establishment and management of protected areas or areas where special measures need to be taken to conserve biological diversity
- 3 regulate or manage biological resources important for the conservation of biological diversity whether within or outside protected areas
- 4 promote the protection of ecosystems, natural habitats and the maintenance of viable populations of species in natural surroundings
- 5 promote environmentally sound and sustainable development in areas adjacent to protected areas
- 6 rehabilitate and restore degraded ecosystems and promote the recovery of threatened species
- 7 establish or maintain means to regulate, manage or control the risks associated with the use and release of living modified organisms resulting from biotechnology which are likely to have adverse environmental impacts
- 8 prevent the introduction of, control or eradicate those alien species which threaten ecosystems, habitats or species
- 9 endeavor to provide the conditions needed for compatibility between present uses and the conservation of biological diversity
- 10 subject to its national legislation, respect, preserve and maintain knowledge
- 11 develop or maintain necessary legislation and/or other regulatory provisions for the protection of threatened species and populations
- 12 where a significant adverse effect on biological diversity regulate or manage the relevant processes and categories of activities
- 13 cooperate in providing financial and other support for in situ conservation, particularly to developing countries.

According to the Commission Communication of 27 March 2001 to the Council and the European Parliament, the Biodiversity Action Plan for the Conservation of Natural Resources (Volume II), the rate of decline and even disappearance of species and related habitats, ecosystems and genes (i.e. biodiversity) increased throughout the world. This loss of biodiversity is deplorable in itself and has adverse effects on economic development since it is the basis for the food, fibers, drink, medicines, industrial processes, agriculture and fisheries activities humans rely on for their survival. The communication sets three main priorities to meet the objective of maintaining or improving the conservation status of natural habitats and wild animal and plant species: application of the Habitats and Birds Directives; establishment of networks such as Natura 2000 and financial and technical support for them; formulating special action plans for threatened and hutable species. The communication sets the objective of adopting the list of Natura 2000 sites for all biogeographical regions, including forested areas, by the end of 2002. The Commission will favor funding Natura 2000 through LIFE-Nature projects.

Following the Commission Communication of 27 March 2001 to the Council and the European Parliament, 'Biodiversity Action Plan for Agriculture' (Volume III), the Community Biodiversity Strategy and the Action Plans are covered by the European Union commitment to achieve sustainable development and integrate environmental

concerns into other sectoral policies and other policy areas. Indicators will be used for the long-term monitoring and benchmarking of Action Plan implementation. These indicators, which still have to be specified by the Commission with the help of the Member States, scientists and organizations concerned, will be measured locally and results compared. The volume on agriculture begins with an analysis of the reciprocal relationship between agriculture and biodiversity stressing mutual benefits but also the pressure on biodiversity from farming. That analysis resulted in the following priorities for the action plan:

- 1 keeping intensive farming at a level which is not harmful to biodiversity by establishing good agricultural practice, reducing the use of fertilizers, supporting non-intensive modes of production and establishing sustainable resource management
- 2 ensuring that farming activities are economically viable, socially acceptable and safeguard biodiversity
- 3 implementing agri-environmental measures for the sustainable use of biodiversity
- 4 ensuring that the necessary ecological infrastructure exists
- 5 supporting measures related to maintaining local breeds and varieties and the diversity of varieties used in agriculture
- 6 preventing the spreading of non-native species.

Another Commission Communication of 27 March 2001 to the Council and the European Parliament, 'Biodiversity Action Plan for Fisheries' (Volume IV), claims that the rate of decline and even disappearance of species and related habitats, ecosystems and genes (i.e. biodiversity) has increased throughout the world. Indicators will be used for the long-term monitoring and benchmarking of Action Plan implementation. These indicators, which still have to be specified by the Commission with the help of the Member States, scientists and organizations concerned, will be measured locally and results compared. The plan identified the following priorities to maintain or restore biodiversity threatened by fishing or aquaculture activities:

- 1 promoting the conservation and sustainable use of fish stocks
- 2 promoting the control of exploitation rates and the establishment of technical conservation measures to support the conservation and sustainable use of fish stocks
- 3 reducing the impact of fisheries activities on non-target species and on marine and coastal ecosystems
- 4 avoiding aquaculture practices that may affect habitat conservation.

Education, training, raising awareness and providing information are essential complements to the effective implementation of this action plan.

The Communication of 27 March 2001 from the Commission to the Council and the European Parliament, 'Biodiversity Action Plan for Economic and Development Cooperation' (volume V), makes clear that there has been a global drop in the number of species and their habitats, ecosystems and genes (in other words biodiversity) and a higher rate of extinction. This loss of biodiversity is regrettable in itself, but it also has negative repercussions for economic development, as biodiversity provides the basis

for basic commodities. The Biodiversity Action Plan on Economic and Development Cooperation will be implemented in the context of the International Development Targets agreed for 2015. These include reversing the trends in environmental degradation and natural resource loss and reducing poverty. As far as poverty is concerned, the aim is to reduce the number of people living in conditions of extreme poverty by half. Biodiversity is an asset for many poor communities and can therefore be used to help reduce their poverty.

A summary of the EU Directive, Decisions and Communications focused on protection of nature and biodiversity – biodiversity is given in Table 4.22.

Protection of nature and biodiversity – fauna and flora

The EU Directive 79/409/EEC (entry into force 6/4/1979) relates to the conservation of all species of naturally occurring birds in the wild state in the European Territory of the Member States to which the Treaty applies. It covers the protection, management and control of these species and lays down rules for their exploitation. It shall apply to birds, their eggs, nests and habitats. This Directive shall not apply to Greenland. The Member States must also conserve, maintain or restore the biotopes and habitats of these birds by:

- 1 creating protection zones
- 2 maintaining the habitats
- 3 restoring destroyed biotopes
- 4 creating biotopes.

Directive establishing a general scheme for the protection of all bird species. The following are prohibited:

- 1 deliberately to kill or capture the bird species covered by the Directives. However, the Directives authorize the hunting of certain species on condition that the methods used comply with certain principles (wise use and balanced control, hunting outside the period of migration or reproduction, prohibition of large-scale or non-selective killing or catching methods)
- 2 to destroy, damage or collect their nests and eggs or removal of their nests
- 3 to disturb them deliberately during the period of breeding and rearing, in so far as disturbance would be significant having regard to the objectives of this Directive
- 4 to take their eggs in the wild and keep these eggs even if empty
- 5 to keep birds of species the hunting and capture of which is prohibited.

According to EU Directive 83/129/EEC (entry into force 1/10/1983), the importation for commercial purposes of certain products of whitecoat pups of harp seals and of pups of hooded seals (blue-backs) is prohibited throughout the Community. The products related are raw furskins and furskins, tanned or dressed, including furskins assembled in plates, bags, crosses and similar forms and articles of these furskins. The Directive does not apply to products resulting from traditional hunting by the Inuit people.

Table 4.22 EU Directive, Decisions and Communications (main points and comments) with regard to protection of nature and biodiversity – biodiversity

Directive	Title	Main points
EU 92/43/EEC (entry into force 10/6/1992)	The conservation of natural habitats and of wild fauna and flora	<ul style="list-style-type: none"> • Habitats Directive, is intended to help maintain biodiversity in the Member States by defining a common framework for the conservation of wild plants and animals and habitats of Community interest • Directive establishes a European ecological network known as 'Natura 2000' • Special areas of conservation are designated in three stages
Decision 82/72/EEC (entry into force 1/9/1982)	Convention on the conservation of European wildlife and natural habitats (Bern Convention)	<ul style="list-style-type: none"> • Wild flora and fauna constitute a natural heritage of great value that needs to be preserved and handed on to future generations • To promote cooperation between the signatory States in order to conserve wild flora and fauna and their natural habitats and to protect endangered migratory species • Standing committee responsible for following the application of the Convention
Decision 93/626/EEC (entry into force 25/10/1993)	Convention on biological diversity	<ul style="list-style-type: none"> • States are responsible for the conservation of their biological diversity and the sustainable use of their biological resources • To exploit their own resources pursuant to their own environmental policies • Economically and socially sound measures that act as incentives for the conservation and sustainable use of components of biological diversity
Commission Communication of 27 March 2001 to the Council and the European Parliament	Biodiversity Action Plan for the Conservation of Natural Resources (Volume II)	<ul style="list-style-type: none"> • To achieve sustainable development and environmental concerns into other sectoral policies and other policy areas • Conservation of wild fauna and flora • Preventing biodiversity loss related to management of water, soil, forests, wetlands
Commission Communication of 27 March 2001 to the Council and the European Parliament	Biodiversity Action Plan for Agriculture (Volume III)	<ul style="list-style-type: none"> • To achieve sustainable development and environmental concerns into other sectoral policies and other policy areas • Long-term monitoring and benchmarking of Action Plan implementation • Volume on agriculture begins with an analysis of the reciprocal relationship between agriculture and biodiversity stressing mutual
Commission Communication of 27 March 2001 to the Council and the European Parliament	Biodiversity Action Plan for Fisheries (Volume IV)	<ul style="list-style-type: none"> • To achieve sustainable development and integrate environmental concerns into other sectoral policies and other policy areas • To maintain or restore biodiversity threatened by fishing or aquaculture activities • To reduce fisheries activities, technical measures and measures to intensify research
Communication of 27 March 2001 from the Commission to the Council and the European Parliament	Biodiversity Action Plan for Economic and Development Cooperation (Volume V)	<ul style="list-style-type: none"> • Biodiversity Action Plan on Economic and Development Cooperation includes reversing the trends in environmental degradation and natural resource loss and reducing poverty • 'Guiding principles' including the ecosystem approach, stakeholder participation, sharing the costs and benefits from biodiversity conservation and giving the public access to information • Action Plan sets out actions to be taken in three inter-linked contexts

Adapted from Arvanitoyannis *et al.*, 2006b

The aim of EU Directive 86/609/EEC (entry into force 28/11/1986) was to ensure that where animals are used for experimental or other scientific purposes, the provisions laid down by law, regulation or administrative provisions in the Member States for their protection are approximated so as to avoid affecting the establishment and functioning of the common market, in particular by distortions of competition or barriers to trade. Member States shall ensure that, as far as the general care and accommodation of animals is concerned:

- 1 all experimental animals shall be provided with housing, an environment, at least some freedom of movement, food, water and care which are appropriate to their health and well-being
- 2 any restriction on the extent to which an experimental animal can satisfy its physiological and ethological needs shall be limited to the absolute minimum
- 3 the environmental conditions in which experimental animals are bred, kept or used must be checked daily
- 4 the well-being and state of health of experimental animals shall be observed by a competent person to prevent pain or avoidable suffering, distress or lasting harm
- 5 arrangements are made to ensure that any defect or suffering discovered is eliminated as quickly as possible. Experiments shall be performed solely by competent authorized persons, or under the direct responsibility of such a person, or if the experimental or other scientific project concerned is authorized in accordance with the provisions of national legislation.

Following the EU Directive 1999/22/EC (entry into force 9/4/1999), the objectives of this Directive are to protect wild fauna and to conserve biodiversity by providing for the adoption of measures by Member States for the licensing and inspection of zoos in the Community, thereby strengthening the role of zoos in the conservation of biodiversity. Member States shall take measures under the Directive to ensure all zoos implement the following conservation measures:

- 1 participating in research from which conservation benefits accrue to the species and/or training in relevant conservation skills
- 2 promoting public education and awareness in relation to the conservation of biodiversity
- 3 accommodating their animals under conditions which aim to satisfy the biological and conservation requirements of the individual species
- 4 preventing the escape of animals in order to avoid possible ecological threats to indigenous species
- 5 keeping of up-to-date records of the zoo's collection appropriate to the species recorded.

The Regulation (EC) No 348/81 (entry into force 1/1/1982) claimed that the introduction into the Community of cetacean products to be used for commercial purposes is

prohibited. An import licence is required for the introduction of products used for other purposes. These include:

- 1 meat and offal, edible or unfit for consumption
- 2 meat extracts and juices
- 3 meat meal and powder, and offal unfit for consumption
- 4 whalebone and similar cetacean products
- 5 greases and oils
- 6 spermaceti from whales and other cetaceans
- 7 products treated with oil from whales or other cetaceans or made from leathers and hides treated with such oil.

The Member States are responsible for issuing import licences. The list of products subject to an import licence may be extended. The following procedure shall be adopted for implementing this Regulation:

- 1 the Commission representative shall submit to the Committee a draft of the provisions to be adopted. The Committee shall deliver an opinion on the draft within a time limit set by the chairman having regard to the urgency of the matter. Decisions shall be taken by a majority of 45 votes and the chairman is not allowed to vote
- 2 The Commission shall adopt the provisions envisaged if they are in accordance with the opinion of the Committee
- 3 If the provisions envisaged are not in accordance with the opinion of the Committee, or if no opinion is delivered, the Commission shall without delay submit to the Council a proposal with regard to the provisions to be adopted.

The object of this Regulation (EC) No 338/97 (entry into force 1/3/1997) is to protect species of wild fauna and flora and to guarantee their conservation by regulating trade therein in accordance with the Articles. The import permit may be issued only in accordance with the restrictions and when the following conditions have been met:

- 1 the competent scientific authority, after considering any opinion by the Scientific Review Group, has advised that the introduction into the Community would not have a harmful effect on the conservation status of the species or on the extent of the territory occupied by the relevant population of the species
- 2 the applicant provides documentary evidence that the specimens have been obtained on the protection of the species concerned which, in the case of import from a third country of specimens of a species shall be an export permit or re-export certificate, or copy thereof
- 3 the competent scientific authority is satisfied that the intended accommodation for a live specimen at the place of destination is adequately equipped to conserve and care for it properly
- 4 the management authority is satisfied that the specimen is not to be used for primarily commercial purposes

- 5 the management authority is satisfied that there are no other factors relating to the conservation of the species which militate against issuance of the import permit
- 6 in the case of introduction from the sea, the management authority is satisfied that any live specimen will be so prepared and shipped as to minimize the risk of injury, damage to health or cruel treatment.

Member States shall take appropriate measures to ensure the imposition of sanctions for at least the following infringements of this Regulation:

- 1 introduction into, or export or re-export from, the Community of specimens without the appropriate permit or certificate or with a false, falsified or invalid permit or certificate or one altered without authorization by the issuing authority
- 2 failure to comply with the stipulations specified on a permit or certificate issued in accordance with this Regulation
- 3 making a false declaration or knowingly providing false information in order to obtain a permit or certificate
- 4 using a false, falsified or invalid permit or certificate or one altered without authorization as a basis for obtaining a Community permit or certificate or for any other official purpose in connection with this Regulation
- 5 making no import notification or a false import notification
- 6 shipment of live specimens not properly prepared so as to minimize the risk of injury, damage to health or cruel treatment
- 7 use of specimens of species given at the time of issuance of the import permit or subsequently
- 8 trade in artificially propagated plants contrary to the provisions
- 9 shipment of specimens into or out of or in transit through the territory of the Community
- 10 purchase, offer to purchase, acquisition for commercial purposes, use for commercial gain
- 11 use of a permit or certificate for any specimen other than one for which it was issued
- 12 falsification or alteration of any permit or certificate issued in accordance with this Regulation
- 13 failure to disclose rejection of an application for a Community import, export or re-export permit or certificate.

The Commission Communication of 1 October 2003, entitled ‘Towards a thematic strategy on the sustainable use of natural resources’ (COM(2003) 572 – not published in the Official Journal), included:

- 1 Raw materials such as minerals (including fossil energy carriers and metal ores) and biomass. Their stocks are finite and are diminishing because of the use by human activities. In contrast, biomass is in principle renewable within the human timeframe.
- 2 Environmental media such as air, water and soil. These resources sustain life and produce biological resources. In contrast with raw materials it is their declining

quality that causes concern. It is not a question of how much there is, but what state they are in.

- 3 Flow resources such as wind, geothermal, tidal and solar energy. These resources cannot be depleted, but require other resources to exploit them.
- 4 Space, as it is obvious that physical space is required to produce or sustain all the abovementioned resources.

The entire life cycle of resources, from their extraction to their final disposal as waste, gives rise to environmental impacts. Two other factors explain why reserves of non-renewable resources tend not to decline:

- 1 efficiency improvements: process improvements mean that a greater proportion of the resources present in reserves can be extracted. In addition, innovation means that we can make more out of a tonne of steel today than we could one century ago.
- 2 recycling: some materials can be recycled to a very high degree, e.g. aluminum. Each tonne of aluminum recycled saves many tonnes of primary raw material.

According to Decision 81/691/EEC (entry into force 4/9/1981), this Convention applies to the Antarctic marine living resources of the area south of 60° South latitude and to the Antarctic marine living resources of the area between that latitude and the Antarctic Convergence which form part of the Antarctic marine ecosystem. Antarctic marine living resources means the populations of fin fish, molluscs, crustaceans and all other species of living organisms, including birds, found south of the Antarctic. Nothing in this Convention and no acts or activities taking place while the present Convention is in force shall:

- 1 constitute a basis for asserting, supporting or denying a claim to territorial sovereignty in the Antarctic Treaty area or create any rights of sovereignty in the Antarctic Treaty area
- 2 be interpreted as a renunciation or diminution by any Contracting Party of, or as prejudicing, any right or claim or basis of claim to exercise coastal State jurisdiction under international law within the area to which this Convention applies
- 3 be interpreted as prejudicing the position of any Contracting Party as regards its recognition or non-recognition of any such right, claim or basis of claim
- 4 affect the provision of the Antarctic Treaty that no new claim, or enlargement of an existing claim, to territorial sovereignty in Antarctica shall be asserted while the Antarctic Treaty is in force.

The objective of Decision 82/461/EEC (entry into force 24/6/1982) is the conservation of migratory species worldwide. Wild animals require special attention because of their importance from the environmental, ecological, genetic, scientific, esthetic, recreational, cultural, educational, social and economic points of view. Parties that are Range States of a migratory species listed in Appendix I shall endeavor:

- 1 to conserve and, where feasible and appropriate, restore those habitats of the species which are of importance in removing the species from danger of extinction

- 2 to prevent, remove, compensate for or minimize, as appropriate, the adverse effects of activities or obstacles that seriously impede or prevent the migration of the species
- 3 to the extent feasible and appropriate, to prevent, reduce or control factors that are endangering or are likely to further endanger the species, including strictly controlling the introduction of, or controlling or eliminating already introduced, exotic species.

An Agreement should, wherever possible, deal with more than one migratory species. Agreements may also provide for:

- 1 research into the species
- 2 the exchange of information on the migratory species
- 3 the restoration or maintenance of a network of suitable habitats for the conservation of the species
- 4 periodic review of the conservation status of the species
- 5 emergency procedures whereby conservation action would be rapidly strengthened.

Furthermore, another Decision, 1999/337/EC (entry into force 27/5/1999), claimed that the objectives of the Agreement are:

- 1 to reduce progressively incidental dolphin mortalities in the tuna purse-seine fishery in the Agreement Area to levels approaching zero, through the setting of annual limits
- 2 with the goal of eliminating dolphin mortality in this fishery, to seek ecologically sound means of capturing large yellowfin tuna not in association with dolphins
- 3 to ensure the long-term sustainability of the tuna stocks in the Agreement Area, as well as that of the living marine resources related to this fishery, taking into consideration the interrelationship among species in the ecosystem, with special emphasis on, inter alia, avoiding, reducing and minimizing by-catches and discards of juvenile tuna and non-target species.

Pursuant to the International Dolphin Conservation Program and in consideration of the objective of this Agreement, the parties shall, inter alia:

- 1 limit total incidental dolphin mortality in the purse-seine tuna fishery in the Agreement Area to no more than 5000 annually
- 2 establish per-stock per-year dolphin mortality caps and review and assess the effects of these caps
- 3 review the measures at a meeting of the parties.

The titles, main points and comments of the EU Directives, Regulations, Communications, Decisions and Proposal for a Directive about protection of nature and biodiversity – fauna and flora are summarized in Table 4.23.

Protection of nature and biodiversity – forests

According to Regulation (EC) No 2494/2000 (entry into force 18/11/2000), the Community shall provide financial assistance and appropriate expertise to promote

Table 4.23 EU Directives, Regulations, Communications, Decisions and Proposal for a Directive (main points and comments) for protection of nature and biodiversity – fauna and flora

Directive	Title	Main points	Comments
EU 79/409/EEC (entry into force 6/4/1979)	The conservation of wild birds	<ul style="list-style-type: none"> ● To protect, manage and regulate all bird species naturally living in the wild within the European territory of the Member States, including the eggs of these birds, their nests and their habitats and regulate the exploitation of these species ● Establishing a general scheme for the protection of all bird species ● To encourage research and activities conducive to the protection, management and exploitation of the bird species 	Amendment Directive EU > 81/854/EEC (entry into force 7/11/1981) > 85/511/EEC (entry into force 25/7/1985) > 86/122/EEC (entry into force 14/4/1986) > 90/656/EEC (entry into force 13/12/1990) > 91/244/EEC (entry into force 27/3/1991) > 94/24/EEC (entry into force 20/7/1994) > 97/49/EEC (entry into force 2/9/1997) ● Correction and amendment of articles
EU 83/129/EEC (entry into force 1/10/1983)	Concerning the importation into the Member States of skins of certain seal pups and products derived therefrom	<ul style="list-style-type: none"> ● Importation for commercial purposes of certain products of whitecoat pups of harp seals and of pups of hooded seals (blue-backs) ● The Directive does not apply to products resulting from traditional hunting by the Inuit people 	Amendment > Directive EU 89/370/EEC (entry into force 4/7/1989) ● Concerning the importation into Member States of skins of certain seal pups and products derived therefrom
EU 86/609/EEC (entry into force 28/11/1986)	The approximation of laws, regulations and administrative provisions of the Member States regarding the protection of animals used for experimental and other scientific purposes	<ul style="list-style-type: none"> ● Directive applies to the use of animals ● Each Member State must prohibit the use of endangered species for experimental purposes ● Persons who carry out experiments or take part in them must be scientifically competent and have the appropriate education and training ● Any animal taken to a breeding supplier or user establishment must be provided with an identification mark in the least painful manner possible 	Amendment > Directive EU 2003/65/EC (entry into force 16/9/2003) ● Addition and replacement in articles
EU 1999/22/EC (entry into force 9/4/1999)	The keeping of wild animals in zoos	<ul style="list-style-type: none"> ● To protect wildlife and to preserve biodiversity by providing for the adoption by the Member States of measures for granting licences and inspecting zoos within the Community ● All zoos will implement the conservation measures ● All zoos must hold a four year licence ● In the event of non-compliance with the legal requirements, the competent authority will bar public access to the zoo or a part of the zoo 	

(Continued)

Table 4.23 (Continued)

Directive	Title	Main points	Comments
Regulation (EC) No 348/81 (entry into force 1/1/1982)	Common rules for imports of whale or other cetacean products	<ul style="list-style-type: none"> • Introduction into the Community of cetacean products to be used for commercial purposes • Import licence is required for the introduction of products • Member States are responsible for issuing import licences • List of products subject to an import licence 	
Regulation (EC) No 338/97 (entry into force 1/3/1997)	The protection of species of wild fauna and flora by regulating trade therein	<ul style="list-style-type: none"> • Principles and provisions of the Convention on International Trade in Endangered Species of Wild Fauna and Flora (CITES) • To impose general import restrictions, or restrictions relating only to certain countries of origin • Regulation establishes derogations for specimens born and bred in captivity or artificially propagated, for specimens in transit and for specimens forming part of personal and household effects or destined for scientific institutions 	<p>Amendment -Regulation (EC)</p> <ul style="list-style-type: none"> > No 1497/2003 (entry into force 30/8/2003) > No 1882/2003 (entry into force 20/11/2003) > No 834/2004 (entry into force 19/5/2004) • Addition and amendment of articles
COM(2003) 572 Not published in the Official Journal	Commission Communication of 1 October 2003: 'Towards a thematic strategy on the sustainable use of natural resources'	<ul style="list-style-type: none"> • Natural resources are classified to the following categories: raw materials, environmental media, flow resources and physical space required to produce or sustain the other resources • Extraction and use of natural resources may reduce the quality of the natural environment in a way that threatens ecosystems 	
Decision 81/691/EEC (entry into force 4/9/1981)	Convention on the conservation of Antarctic marine living resources	<ul style="list-style-type: none"> • Importance of safeguarding the environment and protecting the integrity of the ecosystem of the seas surrounding Antarctica • Contracting Parties, whether or not they are Parties to the Antarctic Treaty, agree that they will not engage in any activities in the Treaty area contrary to the principles and purposes of that Treaty 	
Decision 82/461/EEC (entry into force 24/6/1982)	Convention on the conservation of migratory species of wild animals (Bonn Convention)	<ul style="list-style-type: none"> • Objective of the Bonn Convention is the conservation of migratory species worldwide • Conservation and management of the species may require international agreements 	
Decision 1999/337/EC (entry into force 27/5/1999)	The signature by the European Community to the agreement on the International Dolphin Conservation Program	<ul style="list-style-type: none"> • Agreement aimed at gradually reducing incidental dolphin mortalities in the tuna purse-seine fishery in the Eastern Pacific Ocean to levels approaching zero • Parties to the agreement are obliged to limit total incidental dolphin mortality during tuna fishing to no more than 5000 annually 	

Adapted from Arvanitoyannis *et al.*, 2006b

the conservation and sustainable management of tropical forests and other forests in developing countries, so as to meet the economic, social and environmental demands placed on forests at local, national and global levels. The assistance and expertise provided under this Regulation shall complement and reinforce that provided through other instruments of development cooperation. Activities to be carried out under this Regulation shall aim at:

- 1 raising the status of forests in national policies and integrating forest policies based on sustainable forest management in development planning
- 2 promoting the production and use of wood and non-wood forest products from sustainably managed resources
- 3 contributing to the adequate valuation of forest resources and services
- 4 ensuring active participation of forest-dependent people and local communities in the development of national forest policies and in development planning
- 5 improving coordination and the flow of information between Commission and Member State projects.

Particular attention shall be given to:

- 1 encouraging environmentally and socially responsible private entrepreneurship in the forest products processing and marketing chain
- 2 encouraging the direct participation of cooperation partners in the developing countries
- 3 providing prior information and ensuring the participation of forest-dependent people and local communities in activities carried out under this Regulation
- 4 proper coordination and information flows between the Commission and the Member States in order to ensure coherence of activities in the regions concerned
- 5 gender-specific roles, knowledge, perspectives and contributions of women/girls and men/boys in the management and use of forests.

Following Regulation (EC) No 2152/2003 (entry into force 11/12/2003), a Community scheme for broad-based, harmonized and comprehensive, long-term monitoring of the condition of forests (hereinafter referred to as 'the scheme') is hereby established to:

- 1 continue and further develop monitoring of air pollution and air pollution effects and of other agents and factors that have an impact on forests, such as biotic and abiotic factors and factors of anthropogenic origin, monitoring of forest fires and their causes and effects and forest fire prevention
- 2 assess the requirements for and develop the monitoring of soils, carbon sequestration, climate change effects and biodiversity, as well as protective functions of forests
- 3 continuously evaluate the efficiency of the monitoring activities in the assessment of the condition of forests and the further development of monitoring activity.

The scheme shall provide for actions designed to:

- 1 promote harmonized collection, handling and assessment of data
- 2 improve data evaluation and promote integrated data evaluation at Community level
- 3 improve the quality of data and information gathered under the scheme
- 4 further develop the monitoring activity of the scheme
- 5 enhance the understanding of forests and, in particular, the impact of natural and anthropogenic stresses
- 6 study the dynamics of forest fires and their causes and impacts on forests
- 7 develop indicators as well as methodologies for risk assessment concerning multiple stresses on forests over time and space.

In the Communication from the Commission to the Council and the European Parliament of 4 November 1999 on the EC approach to forests and development, forests and trees are vital assets for developing countries offering economic, social and environmental benefits for both local communities and national economies. They also provide environmental services such as preserving biodiversity and protecting agricultural land. Sustainable forest management (SFM) is the principal objective of forestry development. This concept covers the whole range of environmental, economic and social benefits of forests. Obstacles to the effective implementation of SFM in natural forests are the lack of criteria and indicators for SFM, applicable management systems and relevant experience. Other important factors with a negative impact on the forestry sector are:

- 1 subsidies in adjacent sectors which indirectly encourage deforestation
- 2 current concession and timber pricing policies which create strong incentives for unsustainable management
- 3 the lack of adequate and transparent information on the state and use of forest resources. Forests and trees prevent landslides, protect the soil against erosion and filter water. Forests also contribute to environmental stability at global level, by alternatively producing and absorbing CO₂ they can both contribute to and mitigate climate change. Forest services and products contribute around 2% of world GDP and 3% of international merchandise trade. A more realistic pricing system could increase revenues to the State and slow down the pace of deforestation. The issue of forests concerns a large number of people.

All the EU Regulations and Communication related to protection of nature and biodiversity – forests are given in Table 4.24.

Protection of nature and biodiversity – genetically modified organisms (GMOs)

The EU Directive 90/219/EEC (entry into force 23/10/1991) claimed that the term ‘contained use’ stands for any operation in which microorganisms are genetically modified or in which such GMOs are cultured, stored, used, transported, destroyed or disposed of and for which physical barriers, or a combination of physical barriers

Table 4.24 EU Regulations and Communication (main points and comments) focused on protection of nature and biodiversity – forests

Directive	Title	Main points
Regulation (EC) No 2494/2000 (entry into force 18/11/2000)	Measures to promote the conservation and sustainable management of tropical forests and other forests in developing countries	<ul style="list-style-type: none"> • Conservation and sustainable management of forests are critical for a healthy environment and sustainable development • To promote the conservation and sustainable management of tropical and other forests in developing countries they could be provided with financial assistance and/or technical expertise • Activities carried out pursuant to the Regulation will have five main objectives • Regulation provides for total funding of EUR 249 million for the period 2000–2006
Regulation (EC) No 2152/2003 (entry into force 11/12/2003)	Concerning monitoring of forests and environmental interactions in the Community (Forest Focus)	<ul style="list-style-type: none"> • Establishing Forest Focus seeks to implement forest monitoring and protection activities in four areas • Networks of observation points and plots are to be maintained in order to produce periodic inventories and carry out continuous monitoring of forest ecosystems • Member States may carry out studies, experiments and demonstration projects and establish pilot monitoring schemes
Communication from the Commission to the Council and the European Parliament of 4 November 1999	The EC approach to forests and development	<ul style="list-style-type: none"> • Forests and trees are vital assets for developing countries offering economic, social and environmental benefits • Tropical forests contain half of all known plant and animal species and constitute ecosystems • Forest services and products contribute around 2% of world GDP and 3% of international merchandise trade • Government services are responsible for implementing forestry policy • Need for concerted action to protect forests on an international scale has long been recognized at different levels and in various ways

Adapted from Arvanitoyannis *et al.*, 2006b

together with chemical and/or biological barriers, are used to limit their contact with the general population and the environment. There is no application to the storage, transport, destruction or disposal of GMOs placed on the market under Community legislation, which includes a specific risk assessment similar to that provided in this Directive. Techniques of genetic modification are:

- 1 recombinant DNA techniques using vector systems
- 2 direct introduction into a microorganism of heritable material prepared outside the microorganism
- 3 cell fusion or hybridization techniques.

Techniques of genetic modification to be excluded from the Directive, on condition that they do not involve the use of GMOs as recipient or parental organisms are mutagenesis, the construction and use of somatic animal hybridoma cells, cell fusion of cells from plants which can be produced by traditional breeding methods and self-cloning of non-pathogenic naturally occurring microorganisms.

In EU Directive 2001/18/EC (entry into force 17/4/2001) the laws, regulations and administrative provisions of the Member States should be approximated and human health and the environment should be protected when:

- 1 carrying out the deliberate release into the environment of GMOs for any other purposes than placing on the market within the Community
- 2 placing on the market GMOs as or in products within the Community.

This Directive shall not apply to:

- 1 organisms obtained through the techniques of genetic modification
- 2 the carriage of GMOs by rail, road, inland waterway, sea or air.

The information relating to the release into the environment should report on:

- 1 purpose of the release
- 2 foreseen dates and duration of the release
- 3 method by which the genetically modified plants will be released
- 4 method for preparing and managing the release site, prior to, during and post-release, including cultivation practices and harvesting methods
- 5 approximate number of plants or plants per m².

The information relating to the conditions of release and the receiving environment contains:

- 1 description of the proposed deliberate release
- 2 foreseen dates of the release and time planning of the experiment including frequency and duration of releases
- 3 preparation of the site previous to the release
- 4 size of the site
- 5 methods to be used for the release
- 6 quantities of GMOs to be released
- 7 disturbance on the site (type and method of cultivation, mining, irrigation or other activities)
- 8 worker protection measures taken during the release
- 9 post-release treatment of the site
- 10 techniques foreseen for elimination or inactivation of the GMOs at the end of the experiment
- 11 information on, and results of previous releases of the GMOs.

The potential adverse effects of GMOs may include disease to humans, disease to animals and plants, altered susceptibility to pathogens, effects on the dynamics of populations of species in the receiving environment and the genetic diversity of each of these populations.

Regulation (EC) No 258/97 (entry into force 14/5/1997) refers to the placing on the market within the Community of foods and food ingredients which have not hitherto

been used for human consumption to a significant degree within the Community and which fall in the following categories:

- 1 foods and food ingredients containing or consisting of GMOs
- 2 foods and food ingredients produced from, but not containing, GMOs
- 3 foods and food ingredients with a new or intentionally modified primary molecular structure
- 4 foods and food ingredients consisting of or isolated from microorganisms, fungi or algae
- 5 foods and food ingredients consisting of or isolated from plants and food ingredients isolated from animals, except for foods and food ingredients obtained by traditional propagating or breeding practices and having a history of safe food use
- 6 foods and food ingredients to which has been applied a production process not currently used, where that process gives rise to significant changes in the composition or structure of the foods or food ingredients which affect their nutritional value, metabolism or level of undesirable substances.

Regulation (EC) No 1830/2003 (entry into force 7/11/2003) shall apply, at all stages of the placing on the market, to:

- 1 products consisting of, or containing, GMOs, placed on the market in accordance with Community legislation
- 2 food produced from GMOs, placed on the market in accordance with Community legislation
- 3 feed produced from GMOs, placed on the market in accordance with Community legislation.

At the first stage of the placing on the market of a product consisting of or containing GMOs, including bulk quantities, operators shall ensure that the following information is transmitted in writing to the operator receiving the product that it contains or consists of GMOs and the unique identifier(s) assigned to those GMOs. For products consisting of or containing GMOs, operators shall ensure that:

- 1 for pre-packaged products consisting of, or containing GMOs, the words 'This product contains genetically modified organisms' or 'This product contains genetically modified (name of organism(s))' appear on a label
- 2 for non-pre-packaged products offered to the final consumer the words 'This product contains genetically modified organisms' or 'This product contains genetically modified (name of organism(s))' shall appear.

The adventitious presence of GMOs is an important point to be noted in this Regulation. The threshold is set at 0.5% for this type of 'contamination' for GMOs which have been the subject of a favorable scientific opinion. When placing products produced

from GMOs on the market, operators shall ensure that the following information is transmitted in writing to the operator receiving the product:

- 1 an indication of each of the food ingredients which is produced from GMOs
- 2 an indication of each of the feed materials or additives which is produced from GMOs
- 3 in the case of products for which no list of ingredients exists, an indication that the product is produced from GMOs.

Regulation (EC) No 1830/2003 (entry into force 7/11/2003) is applicable at all stages of the placing on the market to: products consisting of, or containing GMOs placed on the market in accordance with Community legislation, food produced from GMOs placed on the market in accordance with Community legislation and to feed produced from GMOs placed on the market in accordance with Community legislation. Regarding traceability, at the first stage of the placing on the market of a product consisting of or containing GMOs, including bulk quantities, operators shall ensure that the following information is transmitted in writing to the operator receiving the product: that it contains or consists of GMOs and the unique identifier assigned to those GMOs in accordance with the Regulation. When placing products produced from GMOs on the market, operators shall ensure that the following information is transmitted in writing to the operator receiving the product: an indication of each of the food ingredients which is produced from GMOs, an indication of each of the feed materials or additives which is produced from GMOs and in the case of products for which no list of ingredients exists, an indication that the product is produced from GMOs.

Another Regulation (EC) No 1946/2003 (entry into force 25/11/2003) shall apply to the transboundary movements of all GMOs that may have adverse effects on the conservation and sustainable use of biological diversity, also taking into account risks to human health. Pharmaceuticals for humans that are addressed by other relevant international agreements or organizations are excluded from the scope of this Regulation. In cases where the Party of import does not communicate its decisions in response to a notification within 270 days from the date of receiving the notification, the exporter shall send a written reminder, with a deadline for response of 60 days from receipt of this reminder, to the competent authority of that Party of import, with a copy to the Secretariat, to the Member State of export and to the Commission. In calculating the time within which a Party of import is to respond, the number of days it has to wait for additional relevant information shall not be taken into account. Where a Party or non-Party of import does not respond to such a request within 90 days, the exporter shall send a written reminder to the competent authority of that Party or, where appropriate, non-Party of import, with a copy to the Secretariat, requesting a response within a set period following receipt of the reminder. The Commission, on behalf of the Community or, where appropriate, the Member State which made the decision shall inform the BCH and other Parties through the BCH of any final decision regarding use, including placing on the market, within the Community or use within a Member State, of a GMO that may be subject to transboundary movements for direct use as food or feed or for processing. This information shall be sent to the BCH within 15 days of the adoption of that decision.

A summary of the EU Directives and Regulations related to protection of nature and biodiversity – genetically modified organisms (GMOs) is given in Table 4.25.

Table 4.25 EU Directives and Regulations (main points and comments) related to protection of nature and biodiversity – genetically modified organisms (GMOs)

Directive	Title	Main points	Comments
EU 90/219/EEC (entry into force 23/10/1991)	Contained use of GM microorganisms	<ul style="list-style-type: none"> Measures for limited use of GM microorganisms Not applicable to certain techniques of genetic modification Measures for avoidance of adverse effects in human health and environment Emergency plan in case of an accident and regular inspections 	Amendments > Directive EU 98/81/EC (entry into force 5/12/1998) <ul style="list-style-type: none"> Additional elements for the articles
EU 2001/18/EC (entry into force 17/4/2001)	The deliberate release into the environment of genetically modified organisms	<ul style="list-style-type: none"> Making the procedure for granting consent to the deliberate release and placing on the market of GMOs more efficient and more transparent, to limit such consent to a period of ten years (renewable) and to introduce compulsory monitoring after GMOs have been placed on the market Public consultation and GMO labeling are made compulsory Annual report on ethical issues will be published 	Amendment > Regulation (EC) No 1830/2003 (entry into force 7/11/2003) <ul style="list-style-type: none"> Concerning the traceability and labeling of genetically modified organisms and the traceability of food and feed products produced from genetically modified organisms Repeal > Directive EU 90/220/EEC from 17/10/2002
Regulation (EC) No 258/97 (entry into force 14/5/1997)	Novel food and novel food ingredients	<ul style="list-style-type: none"> Placing on the market foods and food ingredients which have not been used for human consumption Not applicable to food additives, flavorings, extraction solvents Specific requirements for labeling and for foodstuffs containing GMOs 	
Regulation (EC) No 1830/2003 (entry into force 7/11/2003)	Concerning the traceability and labeling of genetically modified organisms and the traceability of food and feed products produced from genetically modified organisms	<ul style="list-style-type: none"> Regulation concerns the traceability of GMOs as products or product components, including seeds, and of food or feed products produced from GMOs Traces of GMOs in products will continue to be exempt from the labeling obligation if they do not exceed the threshold of 0.9%. Threshold is set at 0.5% for this type of 'contamination' for GMOs which have been the subject of a scientific opinion 	
Regulation (EC) No 1830/2003 (entry into force 7/11/2003)	Traceability and labeling of GMOs and traceability of food and feed products produced from GMOs	<ul style="list-style-type: none"> Traceability of products consisting of, or containing GMOs and foodstuffs, feed produced from GMOs Application for all stages of disposal on the market Specific demands on labeling 	
Regulation (EC) No 1946/2003 (entry into force 25/11/2003)	Transboundary movement of genetically modified organisms	<ul style="list-style-type: none"> Regulation distinguishes between GMOs intended for deliberate release into the environment and GMOs intended for use as food or feed or for processing Exporters must ensure that the exported GMOs are clearly identified 	

Adapted from Arvanitoyannis *et al.*, 2005

Chemical products

The presence of organic chemicals in the environment often has an effect upon the growth and performance of vegetation. In the simplest form, this describes the activity of herbicides used on land. More complex interactions can include effects upon the chemical itself, including its degradation into simpler compounds; accumulation of the chemicals in the plant and a wide variety of effects upon the plant. These latter effects can occur at any stage during the life cycle of the plant from when the plant emerges from the seed to the adult plant and may result in increases or decreases in plant yield (Bell and Failey, 1991). EPA evaluates existing pesticides that originally were registered when the standards for government approval were less stringent. This comprehensive evaluation and risk mitigation process is complete when EPA is satisfied that the pesticide(s), used in accordance with approved labeling, will not pose unreasonable risks to human health or the environment. EPA's regulatory conclusion about each case is presented in a document called a Reregistration Eligibility Decision (RED). Later, once product-specific data and revised labeling are submitted to EPA and approved, the Agency reregisters products containing the eligible pesticide(s). A pesticide product is not reregistered, however, until all of its active ingredients are eligible for registration (<http://epa.gov/pesticides/factsheets/chemicals/deet.htm>). In the early days of the European Community, it was recognized that there was a need to protect the Community's environment and to create common standards to protect consumers in order to ensure the free circulation of goods among the Member States. For this reason, the first Community environment legislation dealt with various products, among them hazardous chemicals. However, in recent years, drawbacks of the current system have been identified and examined. The most important of these are:

- 1 100 106 existing substances can be used without testing
- 2 burden of proof on public authorities
- 3 no efficient instrument to ensure safe use of the most problematic substances
- 4 lack of incentives for innovation, in particular of less hazardous substitutes.

The REACH proposal focused mainly on the following legislation:

- 1 Directive on the Classification, Packaging and Labeling of Dangerous Substances
- 2 Directive on the Classification, Packaging and Labeling of Dangerous Preparations
- 3 Regulation on the Evaluation and Control of the Risks of Existing Substances
- 4 Directive on Restrictions on the Marketing and Use of certain Dangerous Substances and Preparations (<http://europa.eu.int/comm/environment/chemicals/>).

As use of chemicals is likely to leave residues in foods, the MRL (maximum residue limit) is incorporated into the food standards code which, in turn, is incorporated into state and territory food legislation. Residues in some commodities are monitored at national and state levels to ensure that they are within established standards and do not pose risks to consumers or threaten exports. Several grower groups and exporters also monitor residues as part of their quality-assurance programs (<http://www.rurallaw.org.au/handbook/xml/ch03s06.php>).

Chemical products – hazardous substances and preparations

The purpose of EU Directive 1967/548/EEC (entry into force 29/6/1967) is to approximate the laws, regulations and administrative provisions of the Member States on classification, packaging and labeling of dangerous substances which are placed on the market in the Member States of the Community. The following substances and preparations are ‘hazardous’ within the meaning of this Directive:

- 1 explosive: substances and preparations which may explode under the effect of flame or which are more sensitive to shocks or friction than dinitrobenzene
- 2 oxidizing: substances and preparations which give rise to highly exothermic reaction when in contact with other substances
- 3 easily flammable: substances and preparations which may become hot and finally catch fire in contact with air at ambient temperature without any application of energy or solid substances and preparations which may readily catch fire after brief contact with a source of ignition
- 4 flammable: liquid substances and preparations having a flash point between 21°C and 55°C
- 5 toxic: substances and preparations which, if they are inhaled or taken internally or if they penetrate the skin, may involve serious, acute or chronic health risks and even death
- 6 harmful: substances and preparations which, if they are inhaled or taken internally or if they penetrate the skin, may involve limited health risks
- 7 corrosive: substances and preparations which may, on contact with living tissues, destroy them
- 8 irritant: non-corrosive substances and preparations which, through immediate, prolonged or repeated contact with the skin or mucous membrane, can cause inflammation.

EU Directive 76/769/EEC (entry into force 3/8/1976) shall not apply to:

- 1 the carriage of dangerous substances and preparations by rail, road, inland waterway, sea or air
- 2 hazardous substances and preparations exported to non-member countries
- 3 substances and preparations in transit and subject to customs inspection, provided that they undergo no processing.

For the purposes of this Directive: ‘substances’ means chemical elements and their compounds as they occur in the natural state or as produced by industry, ‘preparations’ means mixtures or solutions composed of two or more substances.

Another EU Directive (1999/45/EC, entry into force 30/7/1999) aims at the approximation of the laws, regulations and administrative provisions of the Member States relating to the classification, packaging and labeling of dangerous preparations and to the approximation of specific provisions for certain preparations which may present hazards, whether or not they are classified as dangerous within the meaning of this Directive, when such preparations are placed on the market of the Member States. This Directive shall not apply to the carriage of dangerous preparations by rail, road,

inland waterway, sea or air and preparations in transit which are under customs supervision, provided they do not undergo any treatment or processing. The evaluation of the hazards of a preparation shall be based on the determination of:

- 1 physicochemical properties
- 2 properties affecting health
- 3 environmental properties.

Member States shall take all necessary measures to ensure that the preparations covered by this Directive cannot be placed on the market unless they comply with it. The name of any substance which led to the classification of the preparation in the following hazard categories: explosive, oxidizing, extremely flammable, highly flammable, flammable, irritant, dangerous for the environment, need not be mentioned on the label unless the substance has to be mentioned pursuant to this Directive. The dangerous health effects have been subdivided into:

- 1 acute lethal effects
- 2 non-lethal irreversible effects after a single exposure
- 3 severe effects after repeated or prolonged exposure
- 4 corrosive effects, irritant effects
- 5 sensitizing effects
- 6 carcinogenic effects, mutagenic effects, toxic effects for reproduction.

The main requirements relating to packaging are as follows:

- 1 the form of packaging and materials used must be strong and solid
- 2 containers which contain hazardous preparations offered or sold to the general public must not have either a shape and/or graphic decoration likely to attract children or mislead consumers nor a presentation similar to that used for foodstuffs or animal feeding stuffs or medicinal or cosmetic products
- 3 preparations offered or sold to the general public must be supplied in a container fitted with child-resistant fastenings and/or carrying a tactile warning of danger.

The objectives of Regulation (EC) No 304/2003 (entry into force 7/3/2003) are:

- 1 to implement the Rotterdam Convention on the Prior Informed Consent Procedure for Certain Hazardous Chemicals and Pesticides in International Trade
- 2 to promote shared responsibility and cooperative efforts in the international movement of hazardous chemicals in order to protect human health and the environment from potential harm
- 3 to contribute to their environmentally sound use.

They shall be achieved by facilitating information exchange about the characteristics of such chemicals, by providing for a decision-making process within the Community

on their import and export and by disseminating decisions to Parties and other countries as appropriate. This Regulation applies to:

- 1 certain hazardous chemicals that are subject to the prior informed consent (PIC) procedure under the Rotterdam Convention
- 2 certain hazardous chemicals that are banned or severely restricted within the Community or a Member State
- 3 all chemicals when exported insofar as their classification, packaging and labeling are concerned.

The Commission, with the support of the Member States as necessary, shall, as appropriate, ensure:

- 1 the provision of publicly available information on regulatory actions relevant to the objectives of the Convention
- 2 the provision of information to Parties and other countries directly or through the Secretariat on those actions which substantially restrict one or more uses of a chemical.

Regulation (EC) No 648/2004 (entry into force 8/10/2005) establishes rules designed to achieve the free movement of detergents and surfactants for detergents in the internal market while, at the same time, ensuring a high degree of protection of the environment and human health. For this purpose, this Regulation harmonizes the following rules for the placing on the market of detergents and of surfactants for detergents: the biodegradability of surfactants in detergents, restrictions or bans on surfactants on grounds of biodegradability, the additional labeling of detergents, including fragrance allergens and the information that manufacturers must hold at the disposal of the Member States' competent authorities and medical personnel. The following information must appear in legible, visible and indelible characters on the packaging in which the detergents are put up for sale to the consumer:

- 1 the name and trade name of the product
- 2 the name or trade name or trademark and full address and telephone number of the party responsible for placing the product on the market
- 3 the address, e-mail address, where available, and telephone number.

The same information must appear on all documents accompanying detergents transported in bulk. By 8 April 2009, the Commission shall carry out a review of the application of this Regulation, paying particular regard to the biodegradability of surfactants and shall evaluate, submit a report on, and, where justified, present legislative proposals relating to: anaerobic biodegradation, the biodegradation of main non-surfactant organic detergent ingredients. The following provisions on labeling shall apply to the packaging of detergents sold to the general public. The following weight percentage ranges:

- 1 less than 5%
- 2 5% or over but less than 15%

- 3 15% or over but less than 30%
- 4 30% and more

shall be used to indicate the content of the constituents listed below where they are added in a concentration above 0.2% by weight: phosphates, phosphonates, anionic surfactants, cationic surfactants, amphoteric surfactants, non-ionic surfactants, oxygen-based bleaching agents, chlorine-based bleaching agents, EDTA and salts thereof, NTA (nitrilotriacetic acid) and salts thereof, phenols and halogenated phenols, paradichlorobenzene, aromatic hydrocarbons, aliphatic hydrocarbons, halogenated hydrocarbons, soap, zeolites, polycarboxylates. The following classes of constituent, if added, shall be listed irrespective of their concentration: enzymes, disinfectants, optical brighteners, perfumes. All ingredients shall be listed in order of decreasing abundance by weight and the list shall be subdivided into the following weight percentage ranges:

- 1 10% or more
- 2 1% or over, but less than 10%
- 3 0.1% or over, but less than 1%
- 4 less than 0.1%.

The Commission White Paper of 27 February 2001 on the strategy for a future chemicals policy (COM(2001) 88 final – not published in the Official Journal) prohibits some harmful chemicals (asbestos, for example). However, there still are gaps in the Community legislation with regard to existing chemical substances. There is a lack of information on the effects of many existing substances placed on the market prior to 1981, when the requirement for the testing and notification of new substances was introduced. Such substances account for approximately 99% of the total volume of substances available on the market and, although the Commission has initiated an assessment of these substances, it is a lengthy process and does not subject existing substances to the same stringent test criteria as new substances. In view of concerns about the harmful effects of chemical substances on human health and the environment, the Commission considers that a strategy must be developed to guarantee the protection of human health and the environment in a context of sustainable development. The substitution of less hazardous chemicals for hazardous chemical substances as soon as feasible will be encouraged. The REACH system is a single system for both existing and new substances covering all phases of the procedure. An eleven-year transition period has been scheduled for existing substances to be assimilated into the new single system. A specific timetable and task force have accordingly been planned to assess the data which already exist. The industry will be responsible for testing and assessing risks. However, evaluation for all substances exceeding a production volume of 100 t or, in case of concern, also for substances at lower tonnage will be carried out by the relevant national authorities in accordance with substance-tailored testing programs focusing on the effects of long-term exposure.

Council Decision of 14 May 2001 on the signature, on behalf of the European Community, of the Stockholm Convention on Persistent Organic Pollutants (POPs)

(COM(2001) 0237 final – not published in the Official Journal) fits into the broader context of the numerous international treaties and conventions concluded on the environment in recent years, such as the Rio Declaration (1992) on Environment and Development for example. POPs are chemical substances which possess certain toxic properties and, unlike other pollutants, resist degradation, which makes them particularly harmful for human health and the environment. POPs accumulate in living organisms, are transported by air, water and migratory species and accumulate in terrestrial and aquatic ecosystems. They are therefore a cross-border problem on which international action is indispensable. Three bodies have been set up to implement the Convention at international level:

- 1 the Conference of the Parties (major decisions): this is the principal body, consisting of all the Parties of the Convention plus, where appropriate, observers
- 2 the Persistent Organic Pollutants Review Committee: this committee, made up of specialists, examines proposals to add new substances to the Convention
- 3 the Secretariat: this body is responsible principally for administrative tasks.

Exports are authorized:

- 1 for environmentally sound disposal of existing POPs (destruction of waste, etc.)
- 2 to a party granted an exemption from the Convention to use the substance in question
- 3 to States which have not signed the Convention.

In the latter case, the importing State must provide annual certification to the exporting Party specifying, among other things, the intended use of the chemical.

The Communication from the Commission to the Council, the European Parliament and the Economic and Social Committee of 24 October 2001 is focused on ‘Dioxins, furans and polychlorinated biphenyls’ (COM(2001) 593 final – not published in the Official Journal) which are among the primary concerns of the European public on account of their serious and multiple effects on the environment and human health. These clinical substances have also been recently implicated in accidents which have emphasized the dangers connected with them. What is more, in some cases, concentrations, particularly of dioxins, have risen appreciably. Although legislation governing these substances exists, the Commission considers that there are shortcomings and that it is becoming urgent to take additional steps to protect human health and the environment. The objectives of the strategy are:

- 1 to assess the current state of the environment and the ecosystem
- 2 to reduce human exposure to dioxins and PCBs in the short term and to maintain human exposure at safe levels in the medium to long term
- 3 to reduce environmental effects from dioxins and PCBs.

The quantitative objective is to reduce human intake levels below 14 picograms WHO-TEQ per kg body weight per week. Dioxins are essentially ‘unintentional by-products’

formed by chemical reactions and combustion processes. They are found particularly in soils and sediments. Dioxins are more toxic than PCBs, but the quantities of PCBs released into the environment are greater. The most important route for human exposure to these substances is food consumption. Cancer is not the only effect of dioxins and is not necessarily, therefore, the major effect to be considered; dioxins can also trigger cognitive disorders, immunosuppression, endometriosis and other problems. Similar effects have been observed in wildlife. Unlike dioxins, PCBs are 'intentionally produced'. They are classified as substances which are probably carcinogenic to man and they have other harmful effects, such as endangering reproduction.

According to the Communication from the Commission of 28 January 2005, 'Community Strategy Concerning Mercury' (COM(2005) 20 – Official Journal C 52 of 2 March 2005), mercury and its compounds are highly toxic to humans, ecosystems and wildlife. High doses can be fatal, but even relatively low doses can damage the nervous system. The purpose of this strategy is to reduce the impact of mercury and the risks it presents for the environment and human health. It is based on the following six objectives:

- 1 reducing mercury emissions
- 2 cutting the supply and demand for mercury
- 3 managing existing amounts of mercury in products still in use or in storage
- 4 protecting against mercury exposure
- 5 improving understanding of the mercury problem and its solutions
- 6 supporting and promoting international action on mercury.

The strategy identifies a certain number of specific actions for each objective. The EU is the world's biggest exporter of mercury. The Commission intends to propose a ban (by 2011) on the export of mercury from the European Union (EU). Moreover, the Commission wants to restrict the marketing of non-electrical or electronic measuring and control equipment containing mercury (for example thermometers) and evaluate the impact of residual mercury use (in particular dental amalgams). The main source of exposure in developed countries is through inhaling mercury vapor from dental amalgam; furthermore, methyl mercury (its most toxic form) collects and concentrates especially in the aquatic food chain (fish, seafood, etc.).

According to Decision 2003/106/EC (entry into force 19/12/2002), the Rotterdam Convention on the Prior Informed Consent Procedure for certain hazardous chemicals and pesticides in international trade, signed on 11 September 1998, was hereby approved on behalf of the European Community. The Convention regulates the import and export of certain hazardous chemicals and pesticides. It is based on the fundamental principle of Prior Informed Consent (PIC). This means that under the Convention, a chemical listed in the Convention may only be exported with the importer's prior consent. The Convention establishes a procedure to disseminate the decisions taken by the importing countries, thus implementing the PIC principle in the international trade in chemicals. It contains provisions requesting detailed information on the chemicals so that these decisions may be taken once data on the properties and the incidence of these

products, in particular on human health and the environment, are available. Over 30 chemicals are currently subject to the PIC procedure. However, certain products are excluded from the scope of the Convention, namely narcotic drugs and psychotropic substances, radioactive materials, wastes, pharmaceuticals, chemical weapons, chemicals used as food additives, food, chemicals.

The Proposal of 29 October 2003 for a regulation of the European Parliament and of the Council concerning the registration, evaluation, authorization and restriction of chemicals (REACH), establishes REACH, a single integrated system for these purposes, together with a European Chemicals Agency. REACH would commit firms which manufacture and import chemicals to evaluate the risks resulting from the use of those chemicals and to take the necessary steps to manage any identified risk. The burden of proof that the safety of chemicals placed on the market is ensured would be reversed and passed from public authorities to industry. The proposed regulation could replace more than 40 directives and regulations currently in force. The following are excluded from the scope of the Directive:

- 1 radioactive substances (because they are covered by other legislations)
- 2 substances under customs supervision which are in temporary storage, in free zones or free warehouses with a view to re-exportation or in transit
- 3 non-isolated intermediates.

Registration is the key component of REACH. It will be compulsory to register, in a central database, chemical substances which are manufactured or imported in quantities of more than one tonne per annum. Failure to register a substance means that it cannot be manufactured or imported. Substances of very high concern are subject to authorization by the Commission with regard to particular uses. Such substances include:

- 1 CMRs (carcinogens, mutagens and reproductive toxins)
- 2 PBTs (persistent, bioaccumulative and toxic substances)
- 3 vPvBs (very persistent and very bioaccumulative substances)
- 4 substances of concern which have irreversible serious effects on humans and the environment, such as endocrine disruptors.

The Communication from the Commission to the Council and the European Parliament of 17 December 2003 refers to a Community strategy for endocrine disruptors. Although the phenomenon of endocrine disruptors is not new, it has only recently attracted significant media attention and has become a cause for public concern. Some Member States have already introduced measures to limit or prohibit certain suspected substances. Though considerable research still needs to be carried out in this area, growing public concern and the various research results already available confirming the problems linked to these substances have prompted the Community to act urgently to address the problem. Endocrine disruptors are agents which appear to interfere with (or 'disrupt') the functioning of glands and hormones. Existing legislation does not necessarily take into account the adverse effects of endocrine disruptors. The strategy is thus based on existing information but should be flexible enough to

incorporate new scientific knowledge. Similarly, the measures are based on an assessment of the likely timeframe within which results can be achieved, i.e. 1–2 years for short-term actions, 2–4 years for medium-term actions and more than 4 years for long-term action. Short-term measures are:

- 1 establishment of a priority list for evaluation
- 2 use of existing legislative instruments
- 3 establishment of monitoring programs
- 4 identification of specific cases
- 5 exchange of information and effective coordination between players
- 6 full public information
- 7 regular consultation of stakeholders.

All the EU Directives, Regulations, Communications, Decisions and Proposals for a Regulation related to chemical products – dangerous substances and preparations are given in Table 4.26.

Chemical products – pesticides

The Communication of 1 July 2002 from the Commission to the Council, the European Parliament and the Economic and Social Committee aims at establishing a thematic strategy on the sustainable use of pesticides (COM(2002) 349 final – not published in the Official Journal) and represents an important step in the preparation of the thematic strategy on sustainable use of pesticides. The objectives formulated by the Council and Parliament are set out below: the communication puts forward ways and means of meeting these objectives in order to initiate the debate during this consultation phase:

First objective: minimizing the hazards and risks to health and environment from the use of pesticides, through:

- 1 establishment of national plans to reduce hazards, risks and dependence on chemical control
- 2 reducing particular risks, such as pollution of watercourses, ditches and water catchment areas and the introduction of chemical control measures in environmentally sensitive areas
- 3 improving knowledge of risks by: monitoring of the health of users at particularly high risk such as agricultural workers and more sensitive consumers; collection of data on incidents having consequences for health and environment of workers.

Second objective: improved controls on the use and distribution of pesticides:

- 1 reporting of production and import/export quantities of PPPs by producers and distributors to national authorities
- 2 reinforcement of ongoing work on the collection of data concerning use (quantities of PPPs applied per crop, product, area, time of application . . .)
- 3 reinforcement of the system (inspections, monitoring of use and distribution of PPP by wholesalers, retailers and farmers)

Table 4.26 EU Directives, Regulations, Communications, Decisions and Proposal for a Regulation (main points and comments) dealing with chemical products – dangerous substances and preparations

Directive	Title	Main points	Comments
EU 1967/548/EEC (entry into force 29/6/1967)	The approximation of laws, regulations and administrative provisions relating to the classification, packaging and labeling of dangerous substances	<ul style="list-style-type: none"> • Provisions relating to packaging and labeling are not applicable to containers for gases which are compressed, liquefied or dissolved under pressure • Definitions (substances, preparations etc.) • Classification of dangerous substances is based on categories • Packaging of substances must comply with three provisions • Labeling must indicate: the name, the origin, the danger symbol and indication of danger 	<p>Amendments</p> <p>Directive EU</p> <ul style="list-style-type: none"> > 1971/144/EEC (entry into force 24/3/1971) > 1973/146/EEC (entry into force 24/5/1973) > 1975/409/EEC (entry into force 27/6/1975) > 1979/831/EEC (entry into force 19/7/1976) > 92/32/EEC (entry into force 22/5/1992) > 96/56/EC (entry into force 21/9/1996) > 1999/33/EC (entry into force 19/8/1999) <ul style="list-style-type: none"> • Correction and amendment of Directives about classification, packaging and labeling of dangerous substances
EU 76/769/EEC (entry into force 3/8/1976)	The approximation of the laws, regulations and administrative provisions of the Member States relating to restrictions on the marketing and use of certain dangerous substances and preparations	<ul style="list-style-type: none"> • Definitions (substances, preparations etc.) • Limits laid down in the Directive are not applicable to products marketed or used for research and development or analysis purposes • List of products covered by the measures provided for in this Directive as well as the conditions governing their placing on the market 	<p>Amendments</p> <p>Directive EU</p> <ul style="list-style-type: none"> > 89/678/EEC (entry into force 4/1/1990) > 91/157/EEC (entry into force 25/3/1991) <ul style="list-style-type: none"> • Additional elements for the articles
EU 1999/45/EC (entry into force 30/7/1999)	The approximation of the laws, regulations and administrative provisions of the Member States relating to the classification, packaging and labeling of dangerous preparations	<ul style="list-style-type: none"> • Main requirements relating to packaging are three • As regards labeling, any package must be clearly and indelibly marked with certain specific information • Member States responsible for the exchange of information with the Commission on the application of this Directive • Not prohibit, restrict or impede the placing on the market of dangerous preparations which satisfy the requirements of the above mentioned Directive • Commission takes the decision on the measure taken by the Member State 	<p>Amendment</p> <ul style="list-style-type: none"> > Directive EU 2004/66/EC (entry into force 1/5/2004) <ul style="list-style-type: none"> • The fields of free movement of goods, freedom to provide services, agriculture, transport policy and taxation, by reason of the accession of the Czech Republic, Estonia, Cyprus, Latvia, Lithuania, Hungary, Malta, Poland, Slovenia and Slovakia
Regulation (EC) No 304/2003 (entry into force 7/3/2003)	The export and import of dangerous chemicals	<ul style="list-style-type: none"> • To implement the provisions of the Rotterdam Convention within the European Community • Certain hazardous chemicals are banned or severely restricted within the Community or a Member State and all chemicals when 	<p>Amendment</p> <ul style="list-style-type: none"> > Regulation (EC) No 1213/2003 (entry into force 27/7/2003) <ul style="list-style-type: none"> • Replacement in the Annexes

(Continued)

Table 4.26 (Continued)

Directive	Title	Main points	Comments
Regulation (EC) No 648/2004 (entry into force 8/10/2005)	Detergents	<p>exported insofar as their classification, packaging and labeling</p> <ul style="list-style-type: none"> • Export measures will apply to exports to all countries and not just to those that have signed the Convention • Regulation will permit improved protection of the aquatic environment against the surfactants in detergents and other cleaning products • Consumers will be better protected against fragrance substances and preservation agents that are present in detergents and can cause allergies • To protect consumers, healthcare professionals will be able to obtain from manufacturers (on request) full listings of the ingredients in detergents so that they can determine whether there is a causal link between a patient's allergy and a product which is present in a detergent 	<p>Repeals</p> <ul style="list-style-type: none"> > Directive EU 73/404/EEC from 8/10/2005 > Directive EU 73/405/EEC from 8/10/2005 > Directive EU 82/242/EEC from 8/10/2005 > Directive EU 82/243/EEC from 8/10/2005 > Directive EU 86/94/EEC from 8/10/2005
COM(2001) 88 final Not published in the Official Journal	Commission White Paper of 27 February 2001 on the strategy for a future chemicals policy	<ul style="list-style-type: none"> • Many tests conducted outside the European Union (EU) should also be recognized: the results can help to fill in the gaps in European data and prevent the duplication of efforts • REACH system is a single system for both existing and new substances covering all phases of the procedure • Registration is mandatory for all substances exceeding a production volume of 1 t 	
COM(2001) 0237 final Not published in the Official Journal	Council Decision of 14 May 2001 on the signature, on behalf of the European Community, of the Stockholm Convention on Persistent Organic Pollutants	<ul style="list-style-type: none"> • POPs are chemical substances which possess certain toxic properties and, unlike other pollutants, resist degradation, which makes them particularly harmful for human health and the environment • Convention provides for ending imports and exports of banned POPs • Goal is to minimize and, where feasible, eliminate unintentional production and release of POPs 	
COM(2001) 593 final Not published in the Official Journal	Communication from the Commission to the Council, the European Parliament and the Economic and Social Committee of 24 October 2001. Community strategy for dioxins, furans and polychlorinated biphenyls	<ul style="list-style-type: none"> • Three groups of substances are persistent chemicals which are particularly toxic to man and the environment • Commission considers that the integrated approach devised by the strategy should permit it to control the problem of dioxins and PCBs in the next ten years • There are short- to medium-term actions and long-term actions 	

(Continued)

Table 4.26 (Continued)

Directive	Title	Main points	Comments
COM(2005) 20 Official Journal C 52 of 2 March 2005	Communication from the Commission of 28 January 2005, 'Community Strategy Concerning Mercury'	<ul style="list-style-type: none"> Mercury and its compounds are highly toxic to humans, ecosystems and wildlife. High doses can be fatal, but even relatively low doses can damage the nervous system Strategy identifies a certain number of specific actions for each objective Although mercury is released by natural sources such as volcanoes, additional releases from human activity 	
Decision 2003/106/EC (entry into force 19/12/2002)	On behalf of the European Community, the Rotterdam Convention on the Prior Informed Consent Procedure for certain hazardous chemicals and pesticides in international trade	<ul style="list-style-type: none"> Convention regulates the import and export of certain hazardous chemicals and pesticides Convention applies to banned or severely restricted chemicals and to severely hazardous pesticide formulations Aim is to facilitate the exchange of scientific, technical, economic and legal information concerning the chemicals 	
Proposal of 29 October 2003 for a Regulation of the European Parliament and of the Council	Concerning the registration, evaluation, authorization and restriction of chemicals (REACH), establishing a European Chemicals Agency	<ul style="list-style-type: none"> A single integrated system for the registration, evaluation and authorization of chemicals, together with a European Chemicals Agency Registration is the key component of REACH New system could encourage research and innovation by raising the registration threshold from the current 10 kg to 1 t 	
Communication from the Commission to the Council and the European Parliament of 17 December 2003	A Community strategy for endocrine disrupters	<ul style="list-style-type: none"> Endocrine system consists of a set of glands and the hormones they produce, which help guide the development, growth, reproduction and behavior of animals, including human beings Strategy is thus based on existing information but should be flexible enough to incorporate new scientific knowledge Measures are based on an assessment of the likely timeframe within which results can be achieved 	

Adapted from Arvanitoyannis *et al.*, 2006b

- 4 introduction of a system of regular and safe collection, possible re-use and controlled destruction of PPP packaging and unused products
- 5 introduction of a system of regular technical inspection of application equipment (sprayers)
- 6 creation of a system of mandatory education, awareness raising, training and certification for all PPP users (farmers, local authorities, workers, distributors, traders and extension services).

Table 4.27 EU Communication (main points and comments) for chemical products – pesticides

Directive	Title	Main points
COM(2002) 349 final Not published in the Official Journal	Communication of 1 July 2002 from the Commission to the Council, the European Parliament and the Economic and Social Committee 'Towards a thematic strategy on the sustainable use of pesticides'	<ul style="list-style-type: none"> • Definition (pesticide) • Use of plant protection products: quantities, benefits, costs and risks of using them • The communication puts forward ways and means of meeting these objectives in order to initiate the debate during this consultation phase • Management of stockpiles of obsolete pesticides in a number of candidate countries has been mentioned repeatedly as an important problem in the context of EU enlargement

Adapted from Arvanitoyannis *et al.*, 2006b

Third objective: reducing the levels of harmful active substances by substituting the most dangerous with safer (including non-chemical) alternatives.

Fourth objective: encouragement of the use of low input or pesticide-free crop farming particularly by raising users' awareness, promoting the use of codes of good practices and consideration of the possible application of financial instruments.

The fifth objective is a transparent system for reporting and monitoring the progress made, including the development of suitable indicators regular reporting on national risk reduction programs and development of suitable indicators for monitoring and definition of quantitative targets.

The EU Communication COM(2002) 349 about chemical products – pesticides is summarized in Table 4.27.

Chemical products – biocidal products

EU Directive 98/8/EC (entry into force 14/5/1998) concerns:

- 1 the authorization and placing on the market of biocidal products in the Member States
- 2 the mutual recognition of authorizations within the Community
- 3 the establishment at Community level of a list of active substances which may be used in biocidal products.

The system of authorization is based on the principle of mutual recognition of authorizations. However, there are a number of derogations from mutual recognition:

- 1 the Member State may request that certain conditions relating to the classification, labeling and packaging of biocidal products be adjusted to the different circumstances. These involve the quantity of the target species in the territory of the Member State, the degree of resistance of the target organism to the biocidal product and the relevant circumstances of use

- 2 where a Member State believes that a low-risk biocidal product, which has been registered in another Member State, does not comply with the definition set out in the Directive it may provisionally refuse to register it. In such cases, it must notify the competent authority responsible for verifying the dossier
- 3 where a Member State believes a biocidal product authorized by another Member State cannot meet the conditions for granting the authorization and proposes to refuse the authorization or registration it must notify the Commission, the other Member States and the applicant. The case will then be referred to the Standing Committee on Biocidal Products for a final and universally binding decision
- 4 save as otherwise provided in the Treaty, Member States may refuse to grant mutual recognition of authorizations issued for types of products used against vermin, fish and birds, provided that such action is justifiable and does not frustrate the objectives of the Directive.

The title, main point and comment of the EU Directive 98/8/EC for chemical products – biocidal products is given in Table 4.28.

Chemical products – fertilizers

The EU Directive 76/116/EEC (entry into force 18/12/1975) made clear that it shall apply to products which are marketed as fertilizers and designated ‘EEC fertilizer’. If the fertilizers are packed, these markings must appear on the packages or labels. For containers with a quantity of fertilizer exceeding 100 kg, these markings need appear only on the accompanying documents. If the fertilizers are in bulk, these markings must appear on the accompanying documents. In order to satisfy the requirements of the Directive, Member States may prescribe that for fertilizers marketed in their territories, indication of the phosphorus, potassium and magnesium contents shall be expressed: solely in the oxide form (P_2O_5 , K_2O , MgO) or solely in the elemental form (P, K, Mg) or in both these forms simultaneously. In the case of packaged fertilizers, the package must be closed in such a way or by such a device that, when it is opened, the fastening, fastening seal or the package itself is irreparably damaged. Valve sacks may be used. Without prejudice to the provisions of other Community Directives, Member States may not on grounds of composition, identification, labeling or

Table 4.28 EU Directive (main points and comments) related to chemical products – biocidal products

Directive	Title	Main points
EU 98/8/EC (entry into force 14/5/1998)	Concerning the placing of biocidal products on the market	<ul style="list-style-type: none"> ● Directive applies to biocidal products ● Member States must ensure the authorization, classification, labeling, packaging and proper use of the biocidal products ● System of authorization is based on the principle of mutual recognition of authorizations ● Directive provides for the possibility of derogation from the requirements for placing biocidal products on the market

Adapted from Arvanitoyannis *et al.*, 2006b

packaging, prohibit, restrict or hinder the marketing of fertilizers marked 'EEC fertilizer' which comply with the provisions of this Directive.

According to EU Directive 80/876/EEC (entry into force 15/7/1980) for the purposes of this Directive, 'fertilizer' means ammonium nitrate based products manufactured chemically for use as fertilizer and containing more than 28% by weight of nitrogen, which may contain inorganic additives or inert substances such as ground limestone or ground dolomite, calcium sulfate, magnesium sulfate and kieserite. The person responsible for marketing the fertilizer, established within the Community, shall certify its conformity by use of the description 'EEC fertilizer'. Only packaged fertilizer may be made available to the final user. Where a Member State has good grounds for believing that a fertilizer, although satisfying the requirements of this Directive, constitutes a hazard to safety or health, it may temporarily prohibit the marketing of the fertilizer in its territory or make it subject to special conditions. It shall immediately inform the other Member States and the Commission thereof, giving the reasons for its decision.

The Regulation (EC) No 2003/2003 (entry into force 11/12/2003) claims that products which are placed on the market as fertilizers are designated 'EC fertilizer'. In order to satisfy the requirements of Article 9, Member States may prescribe that the indication of the nitrogen, phosphorus and potassium contents of fertilizers placed on their market is to be expressed in the following way:

- 1 nitrogen solely in the elemental form (N) and either
- 2 phosphorus and potassium solely in the elemental form (P, K) or
- 3 phosphorus and potassium solely in the oxide form (P_2O_5 , K_2O) or
- 4 phosphorus and potassium in both elemental and oxide forms simultaneously.

Member States may prescribe that the calcium, magnesium, sodium and sulfur contents of secondary nutrient fertilizers and of primary nutrient fertilizers placed on their markets are to be expressed:

- 1 in the oxide form (CaO, MgO, Na_2O , SO_3) or
- 2 in the elemental form (Ca, Mg, Na, S) or
- 3 in both of these forms.

To convert the calcium oxide, magnesium oxide, sodium oxide and sulfur trioxide contents into calcium, magnesium, sodium and sulfur contents, the following factors shall be used:

- 1 calcium (Ca) = calcium oxide (CaO) \times 0.715
- 2 magnesium (Mg) = magnesium oxide (MgO) \times 0.603
- 3 sodium (Na) = sodium oxide (Na_2O) \times 0.742
- 4 sulfur (S) = sulfur trioxide (SO_3) \times 0.400. For the calculated oxide or elemental content, the figure declared shall be rounded to the nearest decimal place.

Some representative points and comments of the EU Directives and Regulation for chemical products – fertilizers are given in Table 4.29.

Table 4.29 EU Directives and Regulation (main points and comments) with regard to chemical products – fertilizers

Directive	Title	Main points	Comments
EU 76/116/EEC (entry into force 18/12/1975)	The approximation of the laws of the Member States relating to fertilizers	<ul style="list-style-type: none"> • Directive applies to solid, straight or compound fertilizers that comply with the technical rules on composition, delimitation and designation • Definitions (EEC fertilizers) • If the fertilizer is packaged, the identification markings must be placed in a conspicuous position, either on the label or on the package • Member States may not on grounds of composition, identification, labeling or packaging, prohibit, restrict or hinder the marketing of fertilizers marked 'EEC fertilizer' which comply with the requirements of the Directive 	Amendments Directive EU > 88/183/EEC (entry into force 22/3/1988) > 89/284/EEC (entry into force 13/4/1989) > 89/530/EEC (entry into force 18/9/1989) > 97/63/EC (entry into force 22/12/1997) > 98/97/EC (entry into force 12/2/1999) <ul style="list-style-type: none"> • Correction and amendment of definitions and articles
EU 80/876/EEC (entry into force 15/7/1980)	The approximation of the laws of the Member States relating to straight ammonium nitrate fertilizers of high nitrogen content	<ul style="list-style-type: none"> • Directive applies to all ammonium nitrate based products containing more than 28% by weight of nitrogen and possibly also containing inorganic additives or inert substances • International rules on the carriage of dangerous substances apply to consignments of such fertilizers • Member States are required to check that fertilizers placed on the market comply with the Directive 	Amendments > Directive EU 97/63/EC (entry into force 26/12/1997) <ul style="list-style-type: none"> • This directive replaces the description 'EEC fertilizer' on the labeling of fertilizers by the words 'EC fertilizer'
Regulation (EC) No 2003/2003 (entry into force 11/12/2003)	Fertilizers	<ul style="list-style-type: none"> • Fertilizers are made up of one or more plant nutrients (or fertilizing elements) • All types of fertilizer which comply with this regulation are designated 'EC fertilizers' and are subject to its provisions • In addition to the provisions regarding the designation of 'EC fertilizers', the regulation sets out provisions for the harmonization of labeling and packaging in the Community • Declaration and identification and packaging of four types of fertilizer • Member States determine the rules on penalties applicable to infringements of the provisions of the Regulation 	Repeals Directive EU > 76/116/EEC (Fertilizers) > 77/535/EEC (Methods of sampling and analysis for fertilizers) > 80/876/EEC (Straight ammonium nitrate fertilizers of high nitrogen content) > 87/94/EEC (Procedures for the control of characteristics of, limits for and resistance to detonation of straight ammonium nitrate fertilizers of high nitrogen content)

Adapted from Arvanitoyannis *et al.*, 2006b

Chemical products – control of the risks

According to EU Directive 96/62/EC (entry into force 3/2/1997), it shall not apply to the following:

- 1 military establishments, installations or storage facilities
- 2 hazards created by ionizing radiation

- 3 the transport of dangerous substances and intermediate temporary storage by road, rail, internal waterways, sea or air, outside the establishments covered by this Directive, including loading and unloading and transport to and from another means of transport at docks, wharves or marshalling yards
- 4 the transport of dangerous substances in pipelines, including pumping stations, outside establishments covered by this Directive
- 5 the activities of the extractive industries concerned with exploration for, and the exploitation of, minerals in mines and quarries or by means of boreholes
- 6 waste landfill sites.

The notification shall contain the following details:

- 1 the name or trade name of the operator and the full address of the establishment concerned
- 2 the registered place of business of the operator, with the full address
- 3 the name or position of the person in charge of the establishment, if different from 1
- 4 information sufficient to identify the dangerous substances or category of substances involved
- 5 the quantity and physical form of the dangerous substance or substances involved
- 6 the activity or proposed activity of the installation or storage facility
- 7 the immediate environment of the establishment (elements liable to cause a major accident or to aggravate the consequences thereof).

Member States shall require the operator to produce a safety report for the purposes of:

- 1 demonstrating that a major accident prevention policy and a safety management system is in place
- 2 demonstrating that major accident hazards have been identified and that the necessary measures have been taken to prevent such accidents and to limit their consequences for man and the environment
- 3 demonstrating that adequate safety and reliability have been incorporated into the design, construction, operation and maintenance of any installation, storage facility, equipment and infrastructure connected with its operation which are linked to major accident hazards inside the establishment
- 4 demonstrating that internal emergency plans have been drawn up and supplying information to enable the external plan to be drawn up in order to take the necessary measures in the event of a major accident
- 5 providing sufficient information to the competent authorities to enable decisions to be made in terms of the siting of new activities or developments around existing establishments.

In EU Directive 98/24/EC (entry into force 25/5/1998) 'chemical agent' means any chemical element or compound, on its own or admixed, as it occurs in the natural state or as produced, used or released, including release as waste, by any work activity, whether or not produced intentionally and whether or not placed on the market. For any

chemical state, Member States shall establish a national occupational exposure limit value, taking into account the Community limit value, determining its nature in accordance with national legislation and practice. Risks to the health and safety of workers at work involving hazardous chemical agents shall be eliminated or reduced to a minimum by:

- 1 the design and organization of systems of work at the workplace
- 2 the provision of suitable equipment for work with chemical agents and maintenance procedures which ensure the health and safety of workers at work
- 3 reducing to a minimum the number of workers exposed or likely to be exposed
- 4 reducing to a minimum the duration and intensity of exposure
- 5 appropriate hygiene measures
- 6 reducing the quantity of chemical agents present at the workplace to the minimum required for the type of work concerned
- 7 suitable working procedures including arrangements for the safe handling, storage and transport within the workplace of hazardous chemical agents and waste containing such chemical agents.

EU Directive 2004/9/EC (entry into force 11/3/2004) refers to the inspection and verification of the organizational processes and the conditions under which laboratory studies are planned, performed, recorded and reported for the non-clinical testing, carried out in accordance with the rules and regulations, of all chemicals (e.g. cosmetics, industrial chemicals, medicinal products, food additives, animal feed additives, pesticides) in order to assess the effect of such products on man, animals and the environment. This Directive does not concern the interpretation and evaluation of test results. Member States shall designate the authorities responsible for the inspection of laboratories within their territories and for the audit of studies carried out by laboratories to assess compliance with Good Laboratory Practice (GLP). The Committee may examine any question which is referred to it by its chairman either on his own initiative or at the request of a representative of a Member State, concerning the implementation of this Directive and in particular regarding:

- 1 cooperation between the authorities designated by the Member States in technical and administrative matters arising from the implementation of GLP
- 2 the exchange of information on the training of inspectors.

A (national) GLP compliance program should be the responsibility of a properly constituted, legally identifiable body adequately staffed and working within a defined administrative framework. Member States should:

- 1 ensure that the (national) GLP Monitoring Authority is directly responsible for an adequate 'team' of inspectors having the necessary technical/scientific expertise or is ultimately responsible for such a team
- 2 publish documents relating to the adoption of GLP principles within their territories

- 3 publish documents providing details of the (national) GLP compliance program, including information on the legal or administrative framework within which the program operates and references to published acts, normative documents (e.g. regulations, codes of practice), inspection manuals, guidance notes, periodicity of inspections and/or criteria for inspection schedules, etc.
- 4 maintain records of test facilities inspected (and their GLP compliance status) and of studies audited for both national and international purposes.

Furthermore, another EU Directive 2004/10/EC (entry into force 11/3/2004) claims that Member States shall adopt the measures necessary for verification of compliance with the principles of Good Laboratory Practice (GLP). These measures shall include, in particular, inspections and study checks in accordance with the recommendations of the OECD in this area. Member States shall notify to the Commission the name or names of the authority or authorities responsible for verifying compliance with the principles of GLP. These test items are frequently synthetic chemicals, but may be of natural or biological origin and, in some circumstances, may be living organisms. The purpose of testing these test items is to obtain data on their properties and/or their safety with respect to human health and/or the environment. Non-clinical health and environmental safety studies covered by the principles of good laboratory practice include work conducted in the laboratory, in greenhouses and in the field. Unless specifically exempted by national legislation, these principles of GLP apply to all non-clinical health and environmental safety studies required by regulation for the purpose of registering or licensing pharmaceuticals, pesticides, food and feed additives, cosmetic products, veterinary drug products and similar products, and for the regulation of industrial chemicals. Each test facility management should ensure that these principles of GLP are complied with, in its test facility.

The Regulation (EEC) No 793/93 (entry into force 4/6/1993) shall apply to:

- 1 the collection, circulation and accessibility of information on existing substances
- 2 the evaluation of the risks of existing substances to man, including workers and consumers, and to the environment, in order to ensure better management of those risks within the framework of Community provisions.

The provisions of this Regulation shall apply without prejudice to Community legislation on the protection of workers and consumers. Special attention shall be given to substances which may have chronic effects, in particular substances known or suspected to be carcinogenic, toxic to reproduction and/or mutagenic or known or suspected to increase the incidence of these effects. Industrial and commercial secrecy shall not apply to:

- 1 the name of the substance, as given in EINECS
- 2 the name of the manufacturer or importer
- 3 data on physico-chemical properties of the substance and on pathways and environmental fate
- 4 the summary results of the toxicological and ecotoxicological tests, in particular data on carcinogenicity, mutagenicity and/or the substance's toxicity for reproduction

- 5 any information relating to the methods and precautions relating to the substance and the emergency measures
- 6 any information which, if withheld, might lead to animal experiments being carried out or repeated needlessly
- 7 analytical methods that make it possible to detect a dangerous substance when discharged into the environment as well as to determine the direct exposure of humans to the substance.

The Communication from the Commission, of 2 June 2003, to the Council and the European Parliament on cooperation in the European Union on preparedness and response to Biological and Chemical agent attacks (Health security) (COM(2003) 320) final – not published in the Official Journal) is a follow-up to the unprecedented terrorist attacks in the USA in September 2001. Governments and international bodies responded to this event by examining the means they had at their disposal to prevent and counter threats and mitigate the effects of such attacks. They also undertook to develop appropriate responses to a new type of threat, that of deliberate releases of biological and chemical agents. This Communication reports on the health aspects of EU action against bioterrorism and reviews the measures taken to strengthen health defenses against deliberate releases of biological and chemical agents. Health authorities and agencies have a crucial role here and must:

- 1 establish effective surveillance,
- 2 familiarize clinicians with the syndromes to look out for
- 3 disseminate case management guidelines
- 4 put in place effective arrangements for prompt notifications to the authorities in charge of collecting and evaluating epidemiological information
- 5 coordinate public health responses.

Bioterrorism has direct consequences, not only for people, but also for the environment, the food chain and property. Preventing terrorist acts and responding to their consequences therefore requires a mobilization of actors and resources in many sectors other than health. Sectors which should be given particular attention include the following:

- 1 food safety
- 2 animal safety
- 3 plant safety
- 4 water safety.

Some points of the EU legislation focused on chemical products – control of the risks related to biological safety are stated in Table 4.30.

Chemical products – management of waste

The EU Directive 91/689/EEC (entry into force 19/12/1991) specified that the object of it is to approximate the laws of the Member States on the controlled management

Table 4.30 EU Directives, Regulation and Communication (main points and comments) for chemical products – control of the risks

Directive	Title	Main points	Comments
EU 96/62/EC (entry into force 3/2/1997)	The control of major accident hazards involving dangerous substances	<ul style="list-style-type: none"> • Directive includes an obligation to notify under the principle that it is illegal for enterprises to hold large quantities of dangerous substances • Member States must require the operator to produce a safety report • Safety report must contain certain specific information, including an updated inventory of the dangerous substances present in the establishment 	Amendments > Directive EU 2003/105/EC (entry into force 31/12/2003) • Additions and corrections in the Articles and Annexes Repeal > Directive EU 82/501/EEC from 4/2/1997
EU 98/24/EC (entry into force 25/5/1998)	The protection of the health and safety of workers from the risks related to chemical agents at work	<ul style="list-style-type: none"> • Definitions (chemical agent, hazardous chemical agent, activity involving chemical agents, occupational exposure limit value etc.) • Member States must keep workers' and employers' organizations informed of these limit values • Where a Member State introduces or revises a national limit value for a chemical agent, it must inform the Commission and other Member States 	
EU 2004/9/EC (entry into force 11/3/2004)	The inspection and verification of good laboratory practice (GLP)	<ul style="list-style-type: none"> • Each Member State designates the authorities responsible for the inspection of laboratories within its territory • Member State is the guarantor that the laboratory is GLP-compliant and this decision is binding in the other Member States • If a Member State considers that a laboratory within its territory claiming GLP compliance does not in fact comply which shall inform the other Member States 	
EU 2004/10/EC (entry into force 11/3/2004)	The harmonization of laws, regulations and administrative provisions relating to the application of the principles of good laboratory practice and the verification of their applications for tests on chemical substances	<ul style="list-style-type: none"> • Purpose of this Directive is to take over all the provisions from the existing Directives in this field • Applies where other Community provisions for the application of the principles of GLP to tests on chemical products to evaluate their safety for man and/or the environment • On grounds relating to the principles of GLP, prohibit, restrict or impede the placing on the market of chemical products 	Repeal > Directive EU 87/18/EEC
Regulation (EEC) No 793/93 (entry into force 4/6/1993)	The evaluation and control of the risks of existing substances	<ul style="list-style-type: none"> • Regulation sets up a program designed to identify and control the risks posed by some of the existing chemical substances listed in EINECS (European Inventory of Existing Commercial Chemical Substances) • Listing of priority substances 	Amendments > Regulation (EC) No 1882/2003 (entry into force 20/11/2003)

(Continued)

Table 4.30 (Continued)

Directive	Title	Main points	Comments
COM(2003) 320 final Not published in the Official Journal	Communication from the Commission, of 2/6/2003, to the Council and the European Parliament on cooperation in the EU on preparedness and response to Biological and Chemical agent attacks (Health security)	<ul style="list-style-type: none"> • Certain information, such as physico-chemical data and summaries of the results of toxicological and ecotoxicological tests, cannot be accorded protection on the grounds of manufacturing and business secrecy • Recent bioterrorist incidents and repercussions in the EU • Public health preparedness and response • Availability and stockpiling of medicines • Bioterrorism has direct consequences not only for people, but also for the environment, the food chain and property 	<ul style="list-style-type: none"> • The provisions relating to committees which assist the Commission in the exercise of its implementing powers laid down in instruments subject to the procedure

Adapted from Arvanitoyannis *et al.*, 2006b

of hazardous waste. Member States shall take the necessary measures to require that on every site where tipping (discharge) of hazardous waste takes place the waste is recorded and identified. Member States shall take the necessary measures to require that establishment and undertaking which dispose of, recover, collect or transport hazardous waste do not mix different categories of hazardous waste or mix hazardous waste with non-hazardous waste. Member States should ensure that, in the course of collection, transport and temporary storage, waste is properly packaged and labeled in accordance with the international and Community standards in force. The Commission shall compare these plans and, in particular, the methods of disposal and recovery. It shall make this information available to the competent authorities of the Member States which ask for it. In cases of emergency or grave danger, Member States shall take all necessary steps, including, where appropriate, temporary derogations from this Directive, to ensure that hazardous waste is so dealt with as not to constitute a threat to the population or the environment.

The purpose of EU Directive 96/59/EC (entry into force 16/9/1996) is to approximate the laws of the Member States on the controlled disposal of PCBs, the decontamination or disposal of equipment containing PCBs and/or the disposal of used PCBs in order to eliminate them completely on the basis of the provisions of this Directive. For the purposes of this Directive: 'PCBs' means:

- 1 polychlorinated biphenyls
- 2 polychlorinated terphenyls

- 3 monomethyl-tetrachlorodiphenyl methane, monomethyl-dichloro-diphenyl methane, monomethyl-dibromo-diphenyl methane
- 4 any mixture containing any of the abovementioned substances in a total of more than 0.005% by weight.

Member States shall ensure that inventories are compiled of equipment with PCB volumes of more than 5 dm³ and shall send summaries of such inventories to the Commission at the latest three years after the adoption of this Directive. Equipment in respect of which it is reasonable to assume that the fluids contain between 0.05% and 0.005% by weight of PCBs may be inventoried and may be labeled as 'PCBs contaminated 0.05%'. The inventories shall comprise the following:

- 1 the names and addresses of the holders
- 2 the location and description of the equipment
- 3 the quantity of PCBs contained in the equipment
- 4 the dates and types of treatment or replacement carried out or envisaged
- 5 the dates of declaration.

If a Member State has already compiled a similar inventory, a new one shall not be required. Inventories shall be regularly updated. Member States shall take the necessary measures to ensure that transformers containing more than 0.05% by weight of PCBs are decontaminated under the following conditions:

- 1 the objective of the decontamination must be to reduce the level of PCBs to less than 0.05% by weight and, if possible, to no more than 0.005% by weight
- 2 the replacement fluid not containing PCBs must entail markedly lesser risks
- 3 the replacement of the fluid must not compromise the subsequent disposal of the PCBs
- 4 the labeling of the transformer after its decontamination must be replaced by the labeling.

According to Decision 93/98/EEC (entry into force 1/2/1993), the EEC approved the Convention on the control of transboundary movements of hazardous wastes and their disposal. The Convention came into force for the EEC on 7 February 1994. The Convention aimed, by means of introducing a system for controlling the export, import and disposal of hazardous wastes and their disposal, at reducing the volume of such exchanges so as to protect human health and the environment. It defines hazardous wastes. Each party may add to the list other wastes listed as hazardous in its national legislation. General obligations:

- 1 it is prohibited to export or import hazardous wastes or other wastes to or from a non-party State
- 2 no wastes may be exported if the State of import has not given its consent in writing to the specific import

- 3 information about proposed transboundary movements must be communicated to the States concerned, by means of a notification form, so that they may evaluate the effects of the proposed movements on human health and the environment
- 4 transboundary movements of wastes must only be authorized where there is no danger attaching to their movement and disposal
- 5 wastes which are to be the subject of a transboundary movement must be packaged, labeled and transported in conformity with international rules and must be accompanied by a movement document
- 6 any party may impose additional requirements that are consistent with the provisions of the Convention.

Another Decision (97/640/EC, entry into force 22/6/1997) refers that the amendment of the Convention on the control of transboundary movements of hazardous wastes and their disposal is hereby approved on behalf of the Community. The text of the amendment is attached to this Decision. The President of the Council is hereby authorized to designate the person(s) empowered to deposit, on behalf of the Community, the instrument of approval with the Secretary General of the United Nations. The aim is to implement all practical measures to ensure that wastes covered by the Convention are handled in such a way that protection of human health and the environment from their harmful effects is guaranteed. Parties may enter into bilateral, multilateral or regional agreements or arrangements regarding transboundary movements of hazardous wastes, with parties or non-parties, provided that these do not derogate from the principles defined by the Convention.

The Green Paper of 26 July 2000 on environmental issues of PVC is a report on the situation of PVC in Europe. Opinions vary on the effects of PVC on human health and the environment, as they do on the measures taken by some Member States to deal with the problem. Nowadays, PVC is one of the most widely used plastics. The European Commission therefore considers that an integrated approach is necessary in order to meet two objectives: the proper functioning of the internal market and a high level of protection for human health and the environment. The Green Paper follows on from the Commission's commitment, in its draft Directive on end-of-life vehicles, to assess the impact of PVC waste on the environment in an 'integrated approach', i.e. throughout the life cycle of PVC. It is the outcome of a three-year study program launched by the Commission on the technical, scientific and economic aspects of the PVC life cycle. The adoption of the Green Paper is an important milestone in the development of a global Community strategy on PVC. The Green Paper deals with two main questions:

- 1 environmental and health questions concerning the use of certain additives in PVC (particularly lead, cadmium and phthalates)
- 2 the question of waste management (landfill, incineration, recycling of PVC waste): PVC waste is expected to increase by about 80% over the next twenty years.

A summary of the EU legislation related to chemical products – management of waste is given in Table 4.31.

Table 4.31 EU Directives/Decisions/Green Paper (main points and comments) dealing with chemical products – management of waste

Directive	Title	Main points	Comments
EU 91/689/EEC (entry into force 19/12/1991)	Hazardous waste	<ul style="list-style-type: none"> List of the hazardous wastes covered by the Directive is to be drawn up on the basis of the categories, constituents and properties set out in the Directive Member States ensure that hazardous waste is recorded and identified Any establishment or undertaking which carries out disposal operations must obtain a permit Competent authorities publish plans for the management of hazardous waste and the Commission evaluates these plans 	Amendments > Directive EU 94/31/EC (entry into force 22/7/1994) • Replacement of the Articles
EU 96/59/EC (entry into force 16/9/1996)	The disposal of polychlorinated biphenyls and polychlorinated terphenyls (PCBs/PCTs)	<ul style="list-style-type: none"> Inventories must be compiled of equipment with PCB volumes of more than 5 dm³ Any equipment which is subject to inventory must be labeled Member States must draw up plans 	Repeal > Directive EU 76/403/EEC
Decision 93/98/EEC (entry into force 1/2/1993)	The conclusion, on behalf of the Community, of the Convention on the control of transboundary movements of hazardous wastes and their disposal (Basle Convention)	<ul style="list-style-type: none"> EEC approves the Convention on the control of transboundary movements of hazardous wastes and their disposal Defines hazardous wastes General obligations To improve and achieve environmentally sound management of hazardous wastes and other wastes 	
Decision 97/640/EC (entry into force 22/6/1997)	The approval, on behalf of the Community, of the amendment to the Convention on the control of transboundary movements of hazardous wastes and their disposal (Basle Convention)	<ul style="list-style-type: none"> Convention aims, by introducing a system for controlling the export, import and disposal of hazardous wastes and their disposal, to reduce the volume of such exchanges so as to protect human health and the environment Transboundary movement is any movement of hazardous wastes or other wastes from an area under the national jurisdiction of one State to or through an area under the national jurisdiction of another State Convention establishes notification procedures 	
Green Paper of 26 July 2000	On environmental issues of PVC	<ul style="list-style-type: none"> Green Paper follows on from the Commission's commitment, in its draft Directive on end-of-life vehicles, to assess the impact of PVC waste on the environment in an 'integrated approach' Deals with two main questions Presents a range of policy options for reducing the impact on human health and the environment and for possible measures to form part of a future Community strategy on PVC 	

Adapted from Arvanitoyannis *et al.*, 2006b

Soil protection

Soils face a number of threats, including climate change, contamination, erosion, loss of biodiversity, loss of organic matter, sealing and compaction that, will reduce their ability to perform their various functions (<http://www.defra.gov.uk/environment/land/>). There is no simple relationship between rates of degradation and the organic carbon content of soil. This is because, although microbial biomass usually increases with organic carbon content, this increase is partially offset by sorption and so less of the chemical is available in soil–water for biodegradation. However, it is frequently observed that chemicals are persistent in peat soils where sorption must overcome the effect of a large biomass (Nicholls, 1991). Half of the EU's land is farmed. Farming has contributed over the centuries to creating and maintaining a variety of valuable semi-natural habitats. EU policies, and notably the Common Agricultural Policy (CAP), are therefore increasingly aimed at heading off the risks of environmental degradation, while encouraging farmers to continue to play a positive role in the maintenance of the countryside and the environment by targeted rural development measures and by contributing to securing farming profitability in the different EU regions. The agri-environmental strategy of the CAP is largely aimed at enhancing the sustainability of agro-ecosystems. The measures set out to address the integration of environmental concerns into the CAP encompass environmental requirements (cross-compliance) and incentives integrated into the market and income policy, as well as targeted environmental measures that form part of the Rural Development Programs (http://europa.eu.int/comm/agriculture/envir/index_en.htm).

Soil protection

EU Directive 96/61/EC (entry into force 30/11/1996) aims at achieving integrated prevention and control of pollution arising from specific activities. It lays down measures designed to prevent or to reduce emissions in the air, water and land from the activities listed, including measures concerning waste, in order to achieve a high level of protection of the environment taken as a whole. Member States shall take the necessary measures to provide that the competent authorities ensure that installations are operated in such a way that:

- 1 all the appropriate preventive measures are taken against pollution, in particular through application of the best available techniques
- 2 no significant pollution is caused
- 3 waste production is avoided
- 4 energy is used efficiently
- 5 the necessary measures are taken to prevent accidents and limit their consequences
- 6 the necessary measures are taken upon definitive cessation of activities to avoid any pollution risk and return the site of operation to a satisfactory state.

One of the objectives of the Communication of 16 April 2002 from the Commission to the Council, the European Parliament, the Economic and Social Committee and the Committee of the Regions, 'Towards a Thematic Strategy for Soil Protection'

Table 4.32 EU Directive and Communication (main points and comments) focused on soil protection

Directive	Title	Main points
EU 96/61/EC (entry into force 30/10/1996)	Integrated pollution prevention and control	<ul style="list-style-type: none"> • Directive concerns highly polluting industrial and agricultural activities • Procedure for applying for, issuing and updating operating permits and minimum requirements to be included in any such permit is laid down • Transitional period (30/10/1999–30/10/2007) is laid down during which existing installations can be brought into conformity with the requirements
COM(2002)179 final Not published in the Official Journal	Communication of 16 April 2002 from the Commission to the Council, the European Parliament, the Economic and Social Committee and the Committee of the Regions 'Towards a Thematic Strategy for Soil Protection'	<ul style="list-style-type: none"> • Communication relates to the protection of soils against erosion and pollution • Examination of the international initiatives taken to address soil degradation • Community thematic strategy for soil was presented in 2004 • Arrangement of control plans and taking into consideration the principles of precaution, anticipation and environmental responsibility

Adapted from Arvanitoyannis *et al.*, 2006b

(COM(2002) 179 final – not published in the Official Journal) is to protect soils against erosion and pollution. The Communication describes the functions of soil, which include:

- 1 producing food
- 2 storing, filtering and transforming minerals, water, organic matter, gases, etc.
- 3 providing raw materials
- 4 being the platform for human activity.

It also identifies the main threats to soil in Europe such as erosion, decline in organic matter, soil contamination, soil sealing, soil compaction, decline in soil biodiversity, salinization, floods and landslides.

The titles, main points and comments of the EU Directive and Communication for soil protection are summarized in Table 4.32.

References

EU legislation

EU Communication and Decision related to action programs – general provisions

COM(2001) 31

(http://europa.eu.int/smartapi/cgi/sga_doc?smartapi!celexplus!prod!DocNumber&lg=en&type_doc=COMfinal&an_doc=2001&nu_doc=31)

Decision No 2179/98/EC

(http://europa.eu.int/smartapi/cgi/sga_doc?smartapi!celexplus!prod!DocNumber&lg=en&type_doc=Decision&an_doc=98&nu_doc=2179)

EU Directive, Regulations, Communication and Decisions dealing with environmental instruments – general provisions

EU 2001/42/EC

(http://europa.eu.int/smartapi/cgi/sga_doc?smartapi!celexplus!prod!DocNumber&lg=en&type_doc=Directive&an_doc=2001&nu_doc=42)

Regulation (EC) No 1210/1990

(http://europa.eu.int/smartapi/cgi/sga_doc?smartapi!celexplus!prod!DocNumber&lg=en&type_doc=Regulation&an_doc=1990&nu_doc=1210)

Regulation (EC) No 1655/2000

(http://europa.eu.int/smartapi/cgi/sga_doc?smartapi!celexplus!prod!DocNumber&lg=en&type_doc=Regulation&an_doc=2000&nu_doc=1655)

Regulation (EC) No 1980/2000

(http://europa.eu.int/smartapi/cgi/sga_doc?smartapi!celexplus!prod!DocNumber&lg=en&type_doc=Regulation&an_doc=2000&nu_doc=1980)

Regulation (EEC) No 761/2001

(http://europa.eu.int/smartapi/cgi/sga_doc?smartapi!celexplus!prod!DocNumber&lg=en&type_doc=Regulation&an_doc=2001&nu_doc=761)

COM(2001) 68

(http://europa.eu.int/smartapi/cgi/sga_doc?smartapi!celexplus!prod!DocNumber&lg=en&type_doc=COMfinal&an_doc=2001&nu_doc=68)

COM(2002) 412

(http://europa.eu.int/smartapi/cgi/sga_doc?smartapi!celexplus!prod!DocNumber&lg=en&type_doc=COMfinal&an_doc=2002&nu_doc=412)

COM(2003) 334

(http://europa.eu.int/smartapi/cgi/sga_doc?smartapi!celexplus!prod!DocNumber&lg=en&type_doc=COMfinal&an_doc=2003&nu_doc=334)

COM(2003) 338

(http://europa.eu.int/smartapi/cgi/sga_doc?smartapi!celexplus!prod!DocNumber&lg=en&type_doc=COMfinal&an_doc=2003&nu_doc=338)

COM(2004) 634

(http://europa.eu.int/smartapi/cgi/sga_doc?smartapi!celexplus!prod!DocNumber&lg=en&type_doc=COMfinal&an_doc=2004&nu_doc=634)

Decision No 466/2002/EC

(http://europa.eu.int/smartapi/cgi/sga_doc?smartapi!celexplus!prod!DocNumber&lg=en&type_doc=Decision&an_doc=2002&nu_doc=466)

Decision 2004/210/EC

(http://europa.eu.int/smartapi/cgi/sga_doc?smartapi!celexplus!prod!DocNumber&lg=en&type_doc=Decision&an_doc=2004&nu_doc=210)

Commission Communication on environmental taxes and charges in the Single Market

(<http://europa.eu.int/scadplus/leg/en/lvb/128058.htm>)

Commission communication: Community guidelines on state aid for environmental protection

(<http://europa.eu.int/scadplus/leg/en/lvb/l26106.htm>)

Recommendation providing for minimum criteria for environmental inspections in the Member States

(<http://europa.eu.int/scadplus/leg/en/lvb/l28080.htm>)

EU Directive, Proposals for a Directive, Decisions and Papers for application and control of Community Environmental Law – general provisions

EU 90/313/EC

(http://europa.eu.int/smartapi/cgi/sga_doc?smartapi!celexplus!prod!DocNumber&lg=en&type_doc=Directive&an_doc=90&nu_doc=313)

COM(2001) 139

(http://europa.eu.int/smartapi/cgi/sga_doc?smartapi!celexplus!prod!DocNumber&lg=en&type_doc=COMfinal&an_doc=2001&nu_doc=139)

Decision 2005/370/EC

(http://europa.eu.int/smartapi/cgi/sga_doc?smartapi!celexplus!prod!DocNumber&lg=en&type_doc=Decision&an_doc=2005&nu_doc=370)

COM(2003) 662

(http://europa.eu.int/smartapi/cgi/sga_doc?smartapi!celexplus!prod!DocNumber&lg=en&type_doc=COMfinal&an_doc=2003&nu_doc=662)

Commission staff working paper of 27 April 1999: First annual survey on the implementation and enforcement of Community environmental law

(<http://europa.eu.int/scadplus/leg/en/lvb/l28111.htm>)

Commission working document of 13 July 2000: second annual study on the implementation and monitoring of the application of Community environment law

(<http://europa.eu.int/scadplus/leg/en/lvb/l28128.htm>)

SEC(2002) 1041

(http://europa.eu.int/smartapi/cgi/sga_doc?smartapi!celexplus!prod!DocNumber&lg=en&type_doc=SEC&an_doc=2002&nu_doc=1041)

SEC(2003) 804

(http://europa.eu.int/smartapi/cgi/sga_doc?smartapi!celexplus!prod!DocNumber&lg=en&type_doc=SEC&an_doc=2003&nu_doc=804)

SEC(2004) 1025

(http://europa.eu.int/smartapi/cgi/sga_doc?smartapi!celexplus!prod!DocNumber&lg=en&type_doc=SEC&an_doc=2004&nu_doc=1025)

EU Communications related to sustainable development – general framework

COM(2001) 264

(http://europa.eu.int/smartapi/cgi/sga_doc?smartapi!celexplus!prod!DocNumber&lg=en&type_doc=COMfinal&an_doc=2001&nu_doc=264)

COM(2002) 82

(http://europa.eu.int/smartapi/cgi/sga_doc?smartapi!celexplus!prod!DocNumber&lg=en&type_doc=COMfinal&an_doc=2002&nu_doc=82)

COM(2003) 829

(http://europa.eu.int/smartapi/cgi/sga_doc?smartapi!celexplus!prod!DocNumber&lg=en&type_doc=COMfinal&an_doc=2003&nu_doc=829)

EU Communications with regard to sustainable development – sustainable development instruments

COM(2002) 122

(http://europa.eu.int/smartapi/cgi/sga_doc?smartapi!celexplus!prod!DocNumber&lg=en&type_doc=COMfinal&an_doc=200&nu_doc=112)

COM(2002) 524

(http://europa.eu.int/smartapi/cgi/sga_doc?smartapi!celexplus!prod!DocNumber&lg=en&type_doc=COMfinal&an_doc=2002&nu_doc=524)

COM(2003) 301

(http://europa.eu.int/smartapi/cgi/sga_doc?smartapi!celexplus!prod!DocNumber&lg=en&type_doc=COMfinal&an_doc=2003&nu_doc=301)

COM(2003) 572

(http://europa.eu.int/smartapi/cgi/sga_doc?smartapi!celexplus!prod!DocNumber&lg=en&type_doc=COMfinal&an_doc=2003&nu_doc=572)

COM(2004) 38

(http://europa.eu.int/smartapi/cgi/sga_doc?smartapi!celexplus!prod!DocNumber&lg=en&type_doc=COMfinal&an_doc=2004&nu_doc=38)

EU Regulation and Communications for sustainable development – integration of environmental policy

Regulation (EC) No 2493/2000

(http://europa.eu.int/smartapi/cgi/sga_doc?smartapi!celexplus!prod!DocNumber&lg=en&type_doc=Regulation&an_doc=2000&nu_doc=2493)

COM(1998) 333

(http://europa.eu.int/smartapi/cgi/sga_doc?smartapi!celexplus!prod!DocNumber&lg=en&type_doc=COMfinal&an_doc=1998&nu_doc=333)

COM(1999) 22

(http://europa.eu.int/smartapi/cgi/sga_doc?smartapi!celexplus!prod!DocNumber&lg=en&type_doc=COMfinal&an_doc=1999&nu_doc=22)

COM(2002) 186

(http://europa.eu.int/smartapi/cgi/sga_doc?smartapi!celexplus!prod!DocNumber&lg=en&type_doc=COMfinal&an_doc=2002&nu_doc=186)

COM(2004) 60

(http://europa.eu.int/smartapi/cgi/sga_doc?smartapi!celexplus!prod!DocNumber&lg=en&type_doc=COMfinal&an_doc=2004&nu_doc=60)

Communication from the Commission: Strengthening environmental integration within Community energy policy

(<http://europa.eu.int/scadplus/leg/en/lvb/128071.htm>)

Communication: Single market and environment

(<http://europa.eu.int/scadplus/leg/en/lvb/128090>)

Communication from the Commission promoting sustainable development in the EU non-energy extractive industry

(<http://europa.eu.int/scadplus/leg/en/lvb/l28113.htm>)

Communication: bringing our needs and responsibilities together – integrating environmental issues and economic policy

(<http://europa.eu.int/scadplus/leg/en/lvb/l28114.htm>)

Commission communication: air transport and the environment

(<http://europa.eu.int/scadplus/leg/en/lvb/l28116.htm>)

Recommendation: concerning the implementation of Integrated Coastal Zone Management in Europe

(<http://europa.eu.int/scadplus/leg/en/lvb/g24229.htm>)

EU Directive, Communications, Decisions and Green Paper dealing with climate change

EU 2003/87/EC

(http://europa.eu.int/smartapi/cgi/sga_doc?smartapi!celexplus!prod!DocNumber&lg=en&type_doc=Directive&an_doc=2003&nu_doc=87)

COM(2001) 580

(http://europa.eu.int/smartapi/cgi/sga_doc?smartapi!celexplus!prod!DocNumber&lg=en&type_doc=COMfinal&an_doc=2001&nu_doc=580)

COM (2003) 492

(http://europa.eu.int/smartapi/cgi/sga_doc?smartapi!celexplus!prod!DocNumber&lg=en&type_doc=COMfinal&an_doc=2003&nu_doc=492)

Decision 2002/358/EC

(http://europa.eu.int/smartapi/cgi/sga_doc?smartapi!celexplus!prod!DocNumber&lg=en&type_doc=Decision&an_doc=2002&nu_doc=358)

Decision 280/2004/EC

(http://europa.eu.int/smartapi/cgi/sga_doc?smartapi!celexplus!prod!DocNumber&lg=en&type_doc=Decision&an_doc=2004&nu_doc=280)

Green Paper

(<http://europa.eu.int/scadplus/leg/en/lvb/l28012.htm>)

EU Directives, Regulation and Communications focused on waste management – general framework

EU 75/442/EEC

(http://europa.eu.int/smartapi/cgi/sga_doc?smartapi!celexplus!prod!DocNumber&lg=en&type_doc=Directive&an_doc=75&nu_doc=442)

EU 96/61/EC

(http://europa.eu.int/smartapi/cgi/sga_doc?smartapi!celexplus!prod!DocNumber&lg=en&type_doc=Directive&an_doc=96&nu_doc=61)

EU 1999/31/EC

(http://europa.eu.int/smartapi/cgi/sga_doc?smartapi!celexplus!prod!DocNumber&lg=en&type_doc=Directive&an_doc=1999&nu_doc=31)

Regulation (EC) No 259/93

(http://europa.eu.int/smartapi/cgi/sga_doc?smartapi!celexplus!prod!DocNumber&lg=en&type_doc=Regulation&an_doc=93&nu_doc=259)

Regulation (EC) No 2150/2002

(http://europa.eu.int/smartapi/cgi/sga_doc?smartapi!celexplus!prod!DocNumber&lg=en&type_doc=Regulation&an_doc=2002&nu_doc=2150)

Communication: the competitiveness of the recycling industries

(<http://europa.eu.int/scadplus/leg/en/lvb/128065.htm>)

COM (2003) 250

(http://europa.eu.int/smartapi/cgi/sga_doc?smartapi!celexplus!prod!DocNumber&lg=en&type_doc=COMfinal&an_doc=2003&nu_doc=250)

COM(2003) 301

(http://europa.eu.int/smartapi/cgi/sga_doc?smartapi!celexplus!prod!DocNumber&lg=en&type_doc=COMfinal&an_doc=2003&nu_doc=301)

EU Directives, Proposals for a Directive and Green Paper dealing with waste management – specific waste

EU 75/439/EEC

(http://europa.eu.int/smartapi/cgi/sga_doc?smartapi!celexplus!prod!DocNumber&lg=en&type_doc=Directive&an_doc=75&nu_doc=439)

EU 78/176/EEC

(http://europa.eu.int/smartapi/cgi/sga_doc?smartapi!celexplus!prod!DocNumber&lg=en&type_doc=Directive&an_doc=78&nu_doc=176)

EU 82/883/EEC

(http://europa.eu.int/smartapi/cgi/sga_doc?smartapi!celexplus!prod!DocNumber&lg=en&type_doc=Directive&an_doc=82&nu_doc=883)

EU 86/278/EEC

(http://europa.eu.int/smartapi/cgi/sga_doc?smartapi!celexplus!prod!DocNumber&lg=en&type_doc=Directive&an_doc=86&nu_doc=278)

EU 91/157/EEC

(http://europa.eu.int/smartapi/cgi/sga_doc?smartapi!celexplus!prod!DocNumber&lg=en&type_doc=Directive&an_doc=91&nu_doc=157)

EU 92/112/EEC

(http://europa.eu.int/smartapi/cgi/sga_doc?smartapi!celexplus!prod!DocNumber&lg=en&type_doc=Directive&an_doc=92&nu_doc=112)

EU 94/62/EC

(http://europa.eu.int/smartapi/cgi/sga_doc?smartapi!celexplus!prod!DocNumber&lg=en&type_doc=Directive&an_doc=94&nu_doc=62)

EU 96/59/EC

(http://europa.eu.int/smartapi/cgi/sga_doc?smartapi!celexplus!prod!DocNumber&lg=en&type_doc=Directive&an_doc=96&nu_doc=59)

EU 2000/53/EC

(http://europa.eu.int/smartapi/cgi/sga_doc?smartapi!celexplus!prod!DocNumber&lg=en&type_doc=Directive&an_doc=2000&nu_doc=53)

EU 2002/95/EC

(http://europa.eu.int/smartapi/cgi/sga_doc?smartapi!celexplus!prod!DocNumber&lg=en&type_doc=Directive&an_doc=2002&nu_doc=95)

EU 2002/96/EC

(http://europa.eu.int/smartapi/cgi/sga_doc?smartapi!celexplus!prod!DocNumber&lg=en&type_doc=Directive&an_doc=2002&nu_doc=96)

COM(2003) 319

(http://europa.eu.int/smartapi/cgi/sga_doc?smartapi!celexplus!prod!DocNumber&lg=en&type_doc=COMfinal&an_doc=2003&nu_doc=319)

COM(2004) 162

(http://europa.eu.int/smartapi/cgi/sga_doc?smartapi!celexplus!prod!DocNumber&lg=en&type_doc=COMfinal&an_doc=2004&nu_doc=162)

Green Paper

(<http://europa.eu.int/scadplus/leg/en/lvb/l28110>)

EU Directives for waste management – incineration of waste

EU 2000/76/EC

(http://europa.eu.int/smartapi/cgi/sga_doc?smartapi!celexplus!prod!DocNumber&lg=en&type_doc=Directive&an_doc=2000&nu_doc=76)

EU 94/67/EC

(http://europa.eu.int/smartapi/cgi/sga_doc?smartapi!celexplus!prod!DocNumber&lg=en&type_doc=Directive&an_doc=94&nu_doc=67)

EU Directive and Decisions related to waste management – hazardous waste

EU 91/689/EEC

(http://europa.eu.int/smartapi/cgi/sga_doc?smartapi!celexplus!prod!DocNumber&lg=en&type_doc=Directive&an_doc=91&nu_doc=689)

Decision 93/98/EEC

(http://europa.eu.int/smartapi/cgi/sga_doc?smartapi!celexplus!prod!DocNumber&lg=en&type_doc=Decision&an_doc=93&nu_doc=98)

Decision 97/640/EC

(http://europa.eu.int/smartapi/cgi/sga_doc?smartapi!celexplus!prod!DocNumber&lg=en&type_doc=Decision&an_doc=97&nu_doc=640)

EU Regulation, Proposal for a Directive and Communication for waste management – radioactive waste and management

Regulation (EC) No 1493/93

(http://europa.eu.int/smartapi/cgi/sga_doc?smartapi!celexplus!prod!DocNumber&lg=en&type_doc=Regulation&an_doc=93&nu_doc=1493)

COM(2003) 32

(http://europa.eu.int/smartapi/cgi/sga_doc?smartapi!celexplus!prod!DocNumber&lg=en&type_doc=COMfinal&an_doc=2003&nu_doc=32)

Council Directive 92/3/Euratom

(<http://europa.eu.int/scadplus/leg/en/lvb/l11020>)

Communication on the present situation and prospects for radioactive waste management in the European Union
(<http://europa.eu.int/scadplus/leg/en/lvb/128097>)

EU Directives, Regulation, Communications and Decisions focused on air pollution – air quality

EU 82/884/EEC

(http://europa.eu.int/smartapi/cgi/sga_doc?smartapi!celexplus!prod!DocNumber&lg=en&type_doc=Directive&an_doc=82&nu_doc=884)

EU 85/203/EEC

(http://europa.eu.int/smartapi/cgi/sga_doc?smartapi!celexplus!prod!DocNumber&lg=en&type_doc=Directive&an_doc=85&nu_doc=203)

EU 96/62/EC

(http://europa.eu.int/smartapi/cgi/sga_doc?smartapi!celexplus!prod!DocNumber&lg=en&type_doc=Directive&an_doc=96&nu_doc=62)

EU 1999/30/EC

(http://europa.eu.int/smartapi/cgi/sga_doc?smartapi!celexplus!prod!DocNumber&lg=en&type_doc=Directive&an_doc=1999&nu_doc=30)

EU 2001/81/EC

(http://europa.eu.int/smartapi/cgi/sga_doc?smartapi!celexplus!prod!DocNumber&lg=en&type_doc=Directive&an_doc=2001&nu_doc=81)

Regulation (EC) No 2037/2000

(http://europa.eu.int/smartapi/cgi/sga_doc?smartapi!celexplus!prod!DocNumber&lg=en&type_doc=Regulation&an_doc=2000&nu_doc=2037)

Communication on the phaseout of CFCs in metered dose inhalers

(<http://europa.eu.int/scadplus/leg/en/lvb/128073>)

Commission communication ‘The Clean Air for Europe (CAFE) Program: Towards a Thematic Strategy for Air Quality’

(<http://europa.eu.int/scadplus/leg/en/lvb/128026>)

Decision 97/101/EC

(http://europa.eu.int/smartapi/cgi/sga_doc?smartapi!celexplus!prod!DocNumber&lg=en&type_doc=Decision&an_doc=97&nu_doc=101)

Decision 2001/379/EC

(http://europa.eu.int/smartapi/cgi/sga_doc?smartapi!celexplus!prod!DocNumber&lg=en&type_doc=Decision&an_doc=2001&nu_doc=379)

EU Directives, Communication and Decision with regard to air pollution – motor vehicles

EU 70/220/EEC

(http://europa.eu.int/smartapi/cgi/sga_doc?smartapi!celexplus!prod!DocNumber&lg=en&type_doc=Directive&an_doc=70&nu_doc=220)

EU 88/77/EEC

(http://europa.eu.int/smartapi/cgi/sga_doc?smartapi!celexplus!prod!DocNumber&lg=en&type_doc=Directive&an_doc=88&nu_doc=77)

EU 93/12/EEC

(http://europa.eu.int/smartapi/cgi/sga_doc?smartapi!celexplus!prod!DocNumber&lg=en&type_doc=Directive&an_doc=93&nu_doc=12)

EU 97/68/EC

(http://europa.eu.int/smartapi/cgi/sga_doc?smartapi!celexplus!prod!DocNumber&lg=en&type_doc=Directive&an_doc=97&nu_doc=68)

EU 98/70/EC

(http://europa.eu.int/smartapi/cgi/sga_doc?smartapi!celexplus!prod!DocNumber&lg=en&type_doc=Directive&an_doc=98&nu_doc=70)

EU 1999/94/EC

(http://europa.eu.int/smartapi/cgi/sga_doc?smartapi!celexplus!prod!DocNumber&lg=en&type_doc=Directive&an_doc=1999&nu_doc=94)

EU 2000/25/EC

(http://europa.eu.int/smartapi/cgi/sga_doc?smartapi!celexplus!prod!DocNumber&lg=en&type_doc=Directive&an_doc=2000&nu_doc=25)

COM(2002) 595

(http://europa.eu.int/smartapi/cgi/sga_doc?smartapi!celexplus!prod!DocNumber&lg=en&type_doc=COMfinal&an_doc=2002&nu_doc=595)

Decision No 1753/2000/EC

(http://europa.eu.int/smartapi/cgi/sga_doc?smartapi!celexplus!prod!DocNumber&lg=en&type_doc=Decision&an_doc=2000&nu_doc=1753)

Commission working paper: Towards a framework for the solution of the environmental problems caused by traffic of heavy goods vehicles

(<http://europa.eu.int/scadplus/leg/en/lvb/l28063>)

EU Directives related to air pollution – industry

EU 94/63/EC

(http://europa.eu.int/smartapi/cgi/sga_doc?smartapi!celexplus!prod!DocNumber&lg=en&type_doc=Directive&an_doc=94&nu_doc=63)

EU 96/61/EC

(http://europa.eu.int/smartapi/cgi/sga_doc?smartapi!celexplus!prod!DocNumber&lg=en&type_doc=Directive&an_doc=96&nu_doc=61)

EU 1999/13/EC

(http://europa.eu.int/smartapi/cgi/sga_doc?smartapi!celexplus!prod!DocNumber&lg=en&type_doc=Directive&an_doc=1999&nu_doc=13)

EU 2001/80/EC

(http://europa.eu.int/smartapi/cgi/sga_doc?smartapi!celexplus!prod!DocNumber&lg=en&type_doc=Directive&an_doc=2001&nu_doc=80)

EU Directive, Communication and Decision on water protection and management – general framework

EU 2000/60/EC

(http://europa.eu.int/smartapi/cgi/sga_doc?smartapi!celexplus!prod!DocNumber&lg=en&type_doc=Directive&an_doc=2000&nu_doc=60)

Decision 2455/2001/EC

(http://europa.eu.int/smartapi/cgi/sga_doc?smartapi!celexplus!prod!DocNumber&lg=en&type_doc=Decision&an_doc=2001&nu_doc=2455)

Communication: Pricing and sustainable management of water resources

(<http://europa.eu.int/scadplus/leg/en/lvb/l28112>)

EU Directives related to water protection and management – specific uses of water

EU 98/38/EC

(http://europa.eu.int/smartapi/cgi/sga_doc?smartapi!celexplus!prod!DocNumber&lg=en&type_doc=Directive&an_doc=98&nu_doc=38)

EU 75/440/EEC

(http://europa.eu.int/smartapi/cgi/sga_doc?smartapi!celexplus!prod!DocNumber&lg=en&type_doc=Directive&an_doc=75&nu_doc=440)

EU 79/869/EEC

(http://europa.eu.int/smartapi/cgi/sga_doc?smartapi!celexplus!prod!DocNumber&lg=en&type_doc=Directive&an_doc=79&nu_doc=869)

EU 76/160/EEC

(http://europa.eu.int/smartapi/cgi/sga_doc?smartapi!celexplus!prod!DocNumber&lg=en&type_doc=Directive&an_doc=76&nu_doc=160)

EU 78/659/EEC

(http://europa.eu.int/smartapi/cgi/sga_doc?smartapi!celexplus!prod!DocNumber&lg=en&type_doc=Directive&an_doc=78&nu_doc=659)

EU 91/271/EEC

(http://europa.eu.int/smartapi/cgi/sga_doc?smartapi!celexplus!prod!DocNumber&lg=en&type_doc=Directive&an_doc=91&nu_doc=271)

EU Regulation, Proposals for Regulation, Communication and Decisions for water protection and management – marine pollution

Regulation (EC) No 782/2003

(http://europa.eu.int/smartapi/cgi/sga_doc?smartapi!celexplus!prod!DocNumber&lg=en&type_doc=Regulation&an_doc=2003&nu_doc=782)

COM(2000) 802

(http://europa.eu.int/smartapi/cgi/sga_doc?smartapi!celexplus!prod!DocNumber&lg=en&type_doc=COMfinal&an_doc=2000&nu_doc=802)

COM(2002) 539

(http://europa.eu.int/smartapi/cgi/sga_doc?smartapi!celexplus!prod!DocNumber&lg=en&type_doc=COMfinal&an_doc=2002&nu_doc=539)

COM(2003) 92

(http://europa.eu.int/smartapi/cgi/sga_doc?smartapi!celexplus!prod!DocNumber&lg=en&type_doc=COMfinal&an_doc=2003&nu_doc=92)

Decision 77/585/EEC

(http://europa.eu.int/smartapi/cgi/sga_doc?smartapi!celexplus!prod!DocNumber&lg=en&type_doc=Decision&an_doc=77&nu_doc=585)

Decision 81/420/EEC

(http://europa.eu.int/smartapi/cgi/sga_doc?smartapi!celexplus!prod!DocNumber&lg=en&type_doc=Decision&an_doc=81&nu_doc=420)

Decision 83/101/EEC

(http://europa.eu.int/smartapi/cgi/sga_doc?smartapi!celexplus!prod!DocNumber&lg=en&type_doc=Decision&an_doc=83&nu_doc=101)

Decision 84/132/EEC

(http://europa.eu.int/smartapi/cgi/sga_doc?smartapi!celexplus!prod!DocNumber&lg=en&type_doc=Decision&an_doc=84&nu_doc=132)

Decision 1999/800/EC

(http://europa.eu.int/smartapi/cgi/sga_doc?smartapi!celexplus!prod!DocNumber&lg=en&type_doc=Decision&an_doc=1999&nu_doc=800)

Decision 1999/801/EC

(http://europa.eu.int/smartapi/cgi/sga_doc?smartapi!celexplus!prod!DocNumber&lg=en&type_doc=Decision&an_doc=1999&nu_doc=801)

Decision 1999/802/EC

(http://europa.eu.int/smartapi/cgi/sga_doc?smartapi!celexplus!prod!DocNumber&lg=en&type_doc=Decision&an_doc=1999&nu_doc=802)

Decision 2004/575/EC

(http://europa.eu.int/smartapi/cgi/sga_doc?smartapi!celexplus!prod!DocNumber&lg=en&type_doc=Decision&an_doc=2004&nu_doc=575)

Decision 94/156/EC

(http://europa.eu.int/smartapi/cgi/sga_doc?smartapi!celexplus!prod!DocNumber&lg=en&type_doc=Decision&an_doc=94&nu_doc=156)

Decision 94/157/EC

(http://europa.eu.int/smartapi/cgi/sga_doc?smartapi!celexplus!prod!DocNumber&lg=en&type_doc=Decision&an_doc=94&nu_doc=157)

Decision 98/249/EC

(http://europa.eu.int/smartapi/cgi/sga_doc?smartapi!celexplus!prod!DocNumber&lg=en&type_doc=Decision&an_doc=98&nu_doc=249)

Decision No 2850/2000/EC

(http://europa.eu.int/smartapi/cgi/sga_doc?smartapi!celexplus!prod!DocNumber&lg=en&type_doc=Decision&an_doc=2000&nu_doc=2850)

Decision 2002/762/EC

(http://europa.eu.int/smartapi/cgi/sga_doc?smartapi!celexplus!prod!DocNumber&lg=en&type_doc=Decision&an_doc=2002&nu_doc=762)

EU Communication and Decisions dealing with water protection and management – inland water

COM(2001) 615

(http://europa.eu.int/smartapi/cgi/sga_doc?smartapi!celexplus!prod!DocNumber&lg=en&type_doc=COMfinal&an_doc=2001&nu_doc=615)

Decision 95/308/EC

(http://europa.eu.int/smartapi/cgi/sga_doc?smartapi!celexplus!prod!DocNumber&lg=en&type_doc=Decision&an_doc=95&nu_doc=308)

Decision 2000/706/EC

(http://europa.eu.int/smartapi/cgi/sga_doc?smartapi!celexplus!prod!DocNumber&lg=en&type_doc=Decision&an_doc=2000&nu_doc=706)

Directives and Regulation related to water protection and management – discharges of substances

EU 76/464/EEC

(http://europa.eu.int/smartapi/cgi/sga_doc?smartapi!celexplus!prod!DocNumber&lg=en&type_doc=Directive&an_doc=76&nu_doc=464)

EU 80/68/EEC

(http://europa.eu.int/smartapi/cgi/sga_doc?smartapi!celexplus!prod!DocNumber&lg=en&type_doc=Directive&an_doc=80&nu_doc=68)

EU 82/176/EEC

(http://europa.eu.int/smartapi/cgi/sga_doc?smartapi!celexplus!prod!DocNumber&lg=en&type_doc=Directive&an_doc=82&nu_doc=176)

EU 91/676/EEC

(http://europa.eu.int/smartapi/cgi/sga_doc?smartapi!celexplus!prod!DocNumber&lg=en&type_doc=Directive&an_doc=91&nu_doc=676)

EU 96/61/EC

(http://europa.eu.int/smartapi/cgi/sga_doc?smartapi!celexplus!prod!DocNumber&lg=en&type_doc=Directive&an_doc=96&nu_doc=61)

Regulation (EC) No 648/2004

(http://europa.eu.int/smartapi/cgi/sga_doc?smartapi!celexplus!prod!DocNumber&lg=en&type_doc=Regulation&an_doc=2004&nu_doc=648)

EU Directive, Decisions and Communications with regard to protection of nature and biodiversity – biodiversity

EU 92/43/EEC

(http://europa.eu.int/smartapi/cgi/sga_doc?smartapi!celexplus!prod!DocNumber&lg=en&type_doc=Directive&an_doc=92&nu_doc=43)

Decision 93/626/EEC

(http://europa.eu.int/smartapi/cgi/sga_doc?smartapi!celexplus!prod!DocNumber&lg=en&type_doc=Decision&an_doc=93&nu_doc=626)

Decision 82/72/EEC

(http://europa.eu.int/smartapi/cgi/sga_doc?smartapi!celexplus!prod!DocNumber&lg=en&type_doc=Decision&an_doc=82&nu_doc=72)

Commission Communication: Biodiversity Action Plan for the Conservation of Natural Resources (Volume II)

(<http://europa.eu.int/scadplus/leg/en/lvb/128023>)

Commission Communication: Biodiversity Action Plan for Agriculture (Volume III)

(<http://europa.eu.int/scadplus/leg/en/lvb/128024>)

Commission Communication: Biodiversity Action Plan for Fisheries (Volume IV)

(<http://europa.eu.int/scadplus/leg/en/lvb/128025>)

Communication: Biodiversity Action Plan for Economic and Development Co-operation (volume V)

(<http://europa.eu.int/scadplus/leg/en/lvb/128037>)

EU Directives, Regulations, Communications, Decisions and Proposal for a Directive for protection of nature and biodiversity – fauna and flora

EU 79/409/EEC

(http://europa.eu.int/smartapi/cgi/sga_doc?smartapi!celexplus!prod!DocNumber&lg=en&type_doc=Directive&an_doc=79&nu_doc=409)

EU 83/129/EEC

(http://europa.eu.int/smartapi/cgi/sga_doc?smartapi!celexplus!prod!DocNumber&lg=en&type_doc=Directive&an_doc=83&nu_doc=129)

EU 86/609/EEC

(http://europa.eu.int/smartapi/cgi/sga_doc?smartapi!celexplus!prod!DocNumber&lg=en&type_doc=Directive&an_doc=86&nu_doc=609)

EU 1999/22/EC

(http://europa.eu.int/smartapi/cgi/sga_doc?smartapi!celexplus!prod!DocNumber&lg=en&type_doc=Directive&an_doc=1999&nu_doc=22)

Regulation (EC) No 348/81

(http://europa.eu.int/smartapi/cgi/sga_doc?smartapi!celexplus!prod!DocNumber&lg=en&type_doc=Regulation&an_doc=81&nu_doc=348)

Regulation (EC) No 338/97

(http://europa.eu.int/smartapi/cgi/sga_doc?smartapi!celexplus!prod!DocNumber&lg=en&type_doc=Regulation&an_doc=97&nu_doc=338)

COM(2003) 572

(http://europa.eu.int/smartapi/cgi/sga_doc?smartapi!celexplus!prod!DocNumber&lg=en&type_doc=COMfinal&an_doc=2003&nu_doc=572)

Decision 81/691/EEC

(http://europa.eu.int/smartapi/cgi/sga_doc?smartapi!celexplus!prod!DocNumber&lg=en&type_doc=Decision&an_doc=81&nu_doc=691)

Decision 82/461/EEC

(http://europa.eu.int/smartapi/cgi/sga_doc?smartapi!celexplus!prod!DocNumber&lg=en&type_doc=Decision&an_doc=82&nu_doc=461)

Decision 1999/337/EC

(http://europa.eu.int/smartapi/cgi/sga_doc?smartapi!celexplus!prod!DocNumber&lg=en&type_doc=Decision&an_doc=1999&nu_doc=337)

Proposal for a Directive introducing humane trapping standards for certain animal species

(<http://europa.eu.int/scadplus/leg/en/lvb/l28147>)

EU Regulations and Communication focused on protection of nature and biodiversity – forests

Regulation (EC) No 2494/2000

(http://europa.eu.int/smartapi/cgi/sga_doc?smartapi!celexplus!prod!DocNumber&lg=en&type_doc=Regulation&an_doc=2000&nu_doc=2494)

Regulation (EC) No 2152/2003

(http://europa.eu.int/smartapi/cgi/sga_doc?smartapi!celexplus!prod!DocNumber&lg=en&type_doc=Regulation&an_doc=2003&nu_doc=2152)

Communication on the EC approach to forests and development

(<http://europa.eu.int/scadplus/leg/en/lvb/l28105>)

EU Directives and Regulations related to protection of nature and biodiversity – genetically modified organisms (GMOs)

EU 90/219/EEC

(http://europa.eu.int/smartapi/cgi/sga_doc?smartapi!celexplus!prod!DocNumber&lg=en&type_doc=Directive&an_doc=90&nu_doc=219)

EU 2001/18/EC

(http://europa.eu.int/smartapi/cgi/sga_doc?smartapi!celexplus!prod!DocNumber&lg=en&type_doc=Directive&an_doc=2001&nu_doc=18)

Regulation (EC) No 258/97

(http://europa.eu.int/smartapi/cgi/sga_doc?smartapi!celexplus!prod!DocNumber&lg=en&type_doc=Regulation&an_doc=97&nu_doc=258)

Regulation (EC) No 1830/2003

(http://europa.eu.int/smartapi/cgi/sga_doc?smartapi!celexplus!prod!DocNumber&lg=en&type_doc=Regulation&an_doc=2003&nu_doc=1830)

Regulation (EC) No 1830/2003

(http://europa.eu.int/smartapi/cgi/sga_doc?smartapi!celexplus!prod!DocNumber&lg=en&type_doc=Regulation&an_doc=2003&nu_doc=1830)

Regulation (EC) No 1946/2003

(http://europa.eu.int/smartapi/cgi/sga_doc?smartapi!celexplus!prod!DocNumber&lg=en&type_doc=Regulation&an_doc=2003&nu_doc=1946)

EU Directives, Regulations, Communications, Decisions and Proposal for a Regulation dealing with chemical products – dangerous substances and preparations

EU 1967/548/EEC

(http://europa.eu.int/smartapi/cgi/sga_doc?smartapi!celexplus!prod!DocNumber&lg=en&type_doc=Directive&an_doc=1967&nu_doc=548)

EU 76/769/EEC

(http://europa.eu.int/smartapi/cgi/sga_doc?smartapi!celexplus!prod!DocNumber&lg=en&type_doc=Directive&an_doc=76&nu_doc=769)

EU 1999/45/EC

(http://europa.eu.int/smartapi/cgi/sga_doc?smartapi!celexplus!prod!DocNumber&lg=en&type_doc=Directive&an_doc=1999&nu_doc=45)

Regulation (EC) No 304/2003

(http://europa.eu.int/smartapi/cgi/sga_doc?smartapi!celexplus!prod!DocNumber&lg=en&type_doc=Regulation&an_doc=2003&nu_doc=304)

Regulation (EC) No 648/2004

(http://europa.eu.int/smartapi/cgi/sga_doc?smartapi!celexplus!prod!DocNumber&lg=en&type_doc=Regulation&an_doc=2004&nu_doc=648)

COM(2001) 88

(http://europa.eu.int/smartapi/cgi/sga_doc?smartapi!celexplus!prod!DocNumber&lg=en&type_doc=COMfinal&an_doc=2001&nu_doc=88)

COM(2001) 0237

(http://europa.eu.int/smartapi/cgi/sga_doc?smartapi!celexplus!prod!DocNumber&lg=en&type_doc=COMfinal&an_doc=2001&nu_doc=0237)

COM(2001) 593

(http://europa.eu.int/smartapi/cgi/sga_doc?smartapi!celexplus!prod!DocNumber&lg=en&type_doc=COMfinal&an_doc=2001&nu_doc=593)

COM(2005) 20

(http://europa.eu.int/smartapi/cgi/sga_doc?smartapi!celexplus!prod!DocNumber&lg=en&type_doc=COMfinal&an_doc=2005&nu_doc=20)

Decision 2003/106/EC

(http://europa.eu.int/smartapi/cgi/sga_doc?smartapi!celexplus!prod!DocNumber&lg=en&type_doc=Decision&an_doc=2003&nu_doc=106)

Proposal for a Regulation concerning the registration, evaluation, authorization and restriction of chemicals (REACH), establishing a European Chemicals Agency

(<http://europa.eu.int/scadplus/leg/en/lvb/l21282>)

Communication on a Community strategy for endocrine disruptors

(<http://europa.eu.int/scadplus/leg/en/lvb/l21277>)

EU Communication for chemical products – pesticides

COM(2002) 349

(http://europa.eu.int/smartapi/cgi/sga_doc?smartapi!celexplus!prod!DocNumber&lg=en&type_doc=COMfinal&an_doc=2002&nu_doc=349)

EU Directive related to chemical products – biocidal products

EU 98/8/EC

(http://europa.eu.int/smartapi/cgi/sga_doc?smartapi!celexplus!prod!DocNumber&lg=en&type_doc=Directive&an_doc=98&nu_doc=8)

EU Directives and Regulation with regard to chemical products – fertilizers

EU 76/116/EEC

(http://europa.eu.int/smartapi/cgi/sga_doc?smartapi!celexplus!prod!DocNumber&lg=en&type_doc=Directive&an_doc=76&nu_doc=116)

EU 80/876/EEC

(http://europa.eu.int/smartapi/cgi/sga_doc?smartapi!celexplus!prod!DocNumber&lg=en&type_doc=Directive&an_doc=80&nu_doc=876)

Regulation (EC) No 2003/2003

(http://europa.eu.int/smartapi/cgi/sga_doc?smartapi!celexplus!prod!DocNumber&lg=en&type_doc=Regulation&an_doc=2003&nu_doc=2003)

EU Directives, Regulation and Communication for chemical products – control of the risks

EU 96/62/EC

(http://europa.eu.int/smartapi/cgi/sga_doc?smartapi!celexplus!prod!DocNumber&lg=en&type_doc=Directive&an_doc=96&nu_doc=62)

EU 98/24/EC

(http://europa.eu.int/smartapi/cgi/sga_doc?smartapi!celexplus!prod!DocNumber&lg=en&type_doc=Directive&an_doc=98&nu_doc=24)

EU 2004/9/EC

(http://europa.eu.int/smartapi/cgi/sga_doc?smartapi!celexplus!prod!DocNumber&lg=en&type_doc=Directive&an_doc=2004&nu_doc=9)

EU 2004/10/EC

(http://europa.eu.int/smartapi/cgi/sga_doc?smartapi!celexplus!prod!DocNumber&lg=en&type_doc=Directive&an_doc=2004&nu_doc=10)

Regulation (EEC) No 793/93

(http://europa.eu.int/smartapi/cgi/sga_doc?smartapi!celexplus!prod!DocNumber&lg=en&type_doc=Regulation&an_doc=93&nu_doc=793)

COM(2003) 320

(http://europa.eu.int/smartapi/cgi/sga_doc?smartapi!celexplus!prod!DocNumber&lg=en&type_doc=COMfinal&an_doc=2003&nu_doc=320)

EU Directives/Decisions/Green Paper dealing with chemical products – management of waste

EU 91/689/EEC

(http://europa.eu.int/smartapi/cgi/sga_doc?smartapi!celexplus!prod!DocNumber&lg=en&type_doc=Directive&an_doc=91&nu_doc=689)

EU 96/59/EC

(http://europa.eu.int/smartapi/cgi/sga_doc?smartapi!celexplus!prod!DocNumber&lg=en&type_doc=Directive&an_doc=96&nu_doc=59)

Decision 93/98/EEC

(http://europa.eu.int/smartapi/cgi/sga_doc?smartapi!celexplus!prod!DocNumber&lg=en&type_doc=Decision&an_doc=93&nu_doc=98)

Decision 97/640/EC

(http://europa.eu.int/smartapi/cgi/sga_doc?smartapi!celexplus!prod!DocNumber&lg=en&type_doc=Decision&an_doc=97&nu_doc=640)

Green Paper on environmental issues of PVC

(<http://europa.eu.int/scadplus/leg/en/lvb/128110>)

EU Directive and Communication focused on soil protection

EU 96/61/EC

(http://europa.eu.int/smartapi/cgi/sga_doc?smartapi!celexplus!prod!DocNumber&lg=en&type_doc=Directive&an_doc=96&nu_doc=61)

COM(2002) 179

(http://europa.eu.int/smartapi/cgi/sga_doc?smartapi!celexplus!prod!DocNumber&lg=en&type_doc=COMfinal&an_doc=2002&nu_doc=179)

EU Communications/Decisions focused on civil protection – general framework

COM(2001) 707

(http://europa.eu.int/smartapi/cgi/sga_doc?smartapi!celexplus!prod!DocNumber&lg=en&type_doc=COMfinal&an_doc=2001&nu_doc=707)

COM(2002) 302

(http://europa.eu.int/smartapi/cgi/sga_doc?smartapi!celexplus!prod!DocNumber&lg=en&type_doc=COMfinal&an_doc=2002&nu_doc=302)

Decision No 2001/792/EC

(http://europa.eu.int/smartapi/cgi/sga_doc?smartapi!celexplus!prod!DocNumber&lg=en&type_doc=Decision&an_doc=2001&nu_doc=792)

e-addresses

- 1 <http://www.lbl.gov/Education/ELSI/pollution-main.html>
- 2 http://www.geocities.com/sebindia/01_04/04-04-1.html
- 3 <http://www.epa.nsw.gov.au/envirom/princairpol.htm>
- 4 <http://edugreen.teri.res.in/explore/air/air.htm>
- 5 http://www.healthfoods.com/Education/Environment_Information/Air_Pollution/toxic_air_pollutants.htm
- 6 <http://europa.eu.int/scadplus/leg/en/lvb/128066.htm>
- 7 <http://www.defra.gov.uk/enviromnent/land/>
- 8 http://europa.eu.int/comm/agriculture/envir/index_en.htm
- 9 http://app.nea.gov.sg/cms/htdocs/category_sub.asp?cid=35
- 10 <http://europa.eu.int/comm/environment/civil/>
- 11 http://www.lgib.gov.uk/european_work/education/protection/index.html
- 12 <http://europa.eu.int/comm/environment/waste/>
- 13 <http://www.lbl.gov/Education/ELSI/Sustain-main.html>
- 14 http://europa.eu.int/comm/sustainable/index_en.htm
- 15 <http://yosemite.epa.gov/OAR/globalwarming.nsf/content/emissions.html>
- 16 <http://www.eia.doe.gov/oiaf/1605/ggccebro/chapter1.html>
- 17 http://europa.eu.int/comm/environment/climate/home_en.htm
- 18 <http://epa.gov/pesticides/factsheets/chemicals/deet.htm>
- 19 <http://europa.eu.int/comm/environment/chemicals/>
- 20 <http://www.rurallaw.org.au/handbook/xml/ch03s06.php>
- 21 http://www.suomi.fi/english/nature_and_the_environment/environmental_protection_and_nature_conservation/
- 22 http://www.unece.org/env/epr/studies/serbia_and_montenegro/chapter09.pdf
- 23 <http://www.rec.org/REC/Progrms/SofiaInitiatives/EcoInstruments/GreenBudget/GreemBudget5/editorial.html>
- 24 <http://europa.eu.int/comm/environment/guide/part2a.htm>
- 25 <http://www.eel.nl/index.asp>
- 26 <http://www.gnet.org/government/lawlibrary/1802.cfm>
- 27 <http://www.grrn.org/landfill/index.html>
- 28 http://www.ucowr.siu.edu/updates/pdf/V113_A5.pdf
- 29 <http://www.eia.doe.gov/emeu/cabs/usenv.html>
- 30 <http://www.grrn.org/resources/BevEPR.html>

Articles

Arvanitoyannis, I.S., Tserkezou, P. and Choreftaki, S. (2006a). Presentation and comments on EU legislation related to food industries – environment interactions and waste management. *Int J Food Sci Technol* **41**(1), 96–129.

- Arvanitoyannis, I.S., Tserkezou, P. and Choreftaki, S. (2006b). Presentation and comments on EU legislation related to food industries – environment interactions: sustainable development and protection of nature and biodiversity – genetically modified organisms. *Int J Food Sci Technol* **41**(7), 813–832.
- Arvanitoyannis, I.S., Tserkezou, P. and Choreftaki, S. (2006c). Presentation and comments on EU legislation related to food industries – environment interactions: organic contaminants (chemicals, pesticides, dioxins, furans, biocides and their waste management). *Int J Food Sci Technol* **41**(7), 833–853.
- Arvanitoyannis, I.S., Choreftaki, S. and Tserkezou, P. (2005). An update of EU legislation (Directives and Regulations) on food-related issues (safety, hygiene, packaging, technology, GMOs, additives, radiation, labelling): presentation and comments. *Int J Food Sci Technol* **40**(10), 2021–2112.
- Bell, R.M. and Failey, R.A. (1991). Plant uptake of organic pollutants. In *Organic contaminants in the environment*. Ed. K.C. Jones. Elsevier Applied Science, Essex, U.K.
- Bontoux, L. and Leone, F. (1997). The legal definition of waste and its impact on waste management in Europe. Office for Official Publications of the European Communities, EUR 17716 EN, November, Luxembourg.
- Calvo, F., Moreno, B., Zamorano, M. and Szanto, M. (2005). Environment diagnosis methodology for municipal waste landfills. *Waste Manage* **25**, 768–779.
- Fries, G.F. (1991). Organic contaminants in terrestrial food chains. In *Organic contaminants in the environment*. Ed. K.C. Jones. Elsevier Applied Science, Essex, U.K.
- Frost and Sullivan. (2001). Ed. K.C. Jones. Environmental legislation and increasing waste boost solid/liquid separation. *Industrial News*, p. 4.
- Gareth, E.J., Ben, D. and Salman, H. (2000). *Ecological economics: an introduction*. Blackwell Science, Oxford, U.K.
- Meneses, M., Schuhmacher, M. and Domingo, J.L. (2004). Health risk assessment of emissions of dioxins and furans from a municipal waste incinerator: comparison with other emission sources. *Environ Int* **30**, 481–489.
- Nemerow, N.L. (1995). *Zero pollution for industry, waste minimization through industrial complexes*. Wiley Interscience Publication, New York.
- Nicholls, P.H. (1991). Organic contaminants in soils and groundwaters. In *Organic contaminants in the environment*. Ed. K.C. Jones. Elsevier Applied Science, Essex, U.K.
- Pongrácz, E. and Pohjola, V.J. (1997). Re-defining waste, the concept of ownership and the role of waste management. *Resources Conservat Recyc* **40**, 141–153.
- Rao, M.N. and Rao, H.V.N. (1989). *Air pollution*. Tata McGraw Hill, New York.
- Ray, B.T. (1995). *Environmental Engineering*. PWS Publishing Company.
- Siemons, R.V. (2002). How European waste will contribute to renewable energy. *Energy policy*, **30**, 471–475.
- Wild, S.R. and Jones, K.C. (1991). Organic contaminants in wastewaters and sewage sludges: transfer to the environment following disposal. In *Organic contaminants in the environment*. Ed. K.C. Jones. Elsevier Applied Science, Essex, U.K.

Presentation and Comments on USA and Canada Legislation Related to Food Industries – Environment Interactions

Ioannis S. Arvanitoyannis and Persefoni Tserkezou

Introduction	289
US legislation for environment	293
Canadian legislation for environment	317

Introduction

In the USA, the state and local governments must have regulations that are at least as stringent as those of the federal government. However, they can enact regulations that are more stringent. Because of the potential liability associated with non-compliance, it is critically important for the organization to have a mechanism in place so it can remain current on regulatory developments at the local, state, national and international levels. A lack of knowledge or understanding does not absolve an organization from the responsibility of complying with regulations. Furthermore, a lack of compliance can seriously affect the financial well-being of the organization and individuals within the organization. Administrative and civil penalties under the major environmental statutes in the USA can reach \$25 000 per violation or day of violation. Administrative penalties are typically assigned for lesser problems or when the agency wants a quick resolution of the problem. When the Environmental Protection

Agency (EPA) seeks civil or criminal penalties, the case is referred to the Department of Justice (Ritchie and Hayes, 1998). The rule making process involves publishing proposed regulations in the Federal Register (FR), providing for public comment through public hearings or written comments and publishing final regulations in the FR. The final regulations become effective on the published dates, unless otherwise noted in the final rule. The FR also contains the regulatory history and explanations (including responses to public comments) for the agency's proposals. The FR has a monthly index and a monthly 'List of Sections Affected', which allow the user to locate changes in the regulations since the FR was issued. The final rules are published once each year in the Code of Federal Regulations (CFR).

In 1919, the American Petroleum Institute (API) was founded as a result of awareness by the petroleum industry that a lack of standardization had been a primary contributor to the shortages experienced by industry around the turn of the century. With additional pressure on the oil industry coming from regulatory agencies, the API began to invest heavily in environmental stewardship. The result was, in 1990, the creation of STEP – Strategies for Today's Environmental Partnership. It is a basic system for preventing pollution, conserving natural resources, measuring progress, promoting product stewardship, maintaining crisis readiness, addressing community concerns and working with government agencies (Culley, 1998). The great advantage of these principles is their great similarity to the ISO 14001 framework. The American Petroleum Institute is also encouraging the petroleum industry constituents to register with ISO 14001, especially if they wish to conduct international business or comply with an international environmental management system.

The environmental regulatory movement in the USA actually began several decades before the creation of the EPA and started with the Federal Insecticide, Fungicide and Rodenticide Act in 1947 and the Air Pollution Control Act of 1955. However, it was not until the late 1960s that the government began to take more aggressive and pragmatic steps to control environmental pollution. In 1969, the US Federal government passed a statute known as the National Environmental Policy Act (NEPA) which was enacted in response to a growing concern over environmental harm resulting from population growth, high-density urbanization, industrial expansion and resource exploitation. The Environmental Protection Agency was involved in the development of ISO 14001 and primarily engineered two of the requirements now in the standards: pollution prevention and compliance management. With ISO 14001, someone will notice the compatibility with Responsible Care. A key difference is that Responsible Care is a series of very specific management initiatives, while ISO 14001 is a very broad-based environmental management system.

The US Congress puts together environmental laws. For such legislation to be enacted, law makers must perceive that environmental regulation benefits society. Only after legislators see the public interest in and the public's desire for such laws will they be passed. In the USA, a law can be passed by a simple majority of the House of Representatives and the Senate if the bill is signed by the president. However, if the president vetoes the bill, a two-thirds majority of both houses is required to override. Several important pieces of environmental legislation were passed over presidential vetoes during the past 25 years. When Congress passes environmental legislation, it directs the

appropriate federal agency to develop and publish regulations to implement it. Before 1970, the US Public Health Service was the agency most concerned about environmental matters. In 1970, Congress created the US Environmental Protection Agency. Since then, the EPA has been responsible for enforcing applicable federal laws. In many cases, the laws allow the states to adopt and enforce the federal laws. Environmental law started in 1899. The event was passage of the Rivers and Harbors Acts, the purpose of which was to prevent the discharge of materials that would impede river traffic into navigable waterways (Ray, 1995). Extended Producer Responsibility (EPR) is an emerging principle for a new generation of pollution prevention policies that focus on product systems instead of production facilities. The aim of EPR is to encourage producers to prevent pollution and reduce resource and energy use in each stage of the product life cycle through changes in product design and process technology. In its widest sense, Producer Responsibility is the principle that producers bear a degree of responsibility for all the environmental impacts of their products. This includes upstream impacts arising from the choice of materials and from the manufacturing process and downstream impacts from the use and disposal of products. Producers accept their responsibility when they accept legal, physical or economic responsibility for the environmental impacts that cannot be eliminated by design. In the longer term, the goals of EPR are to promote the development of sustainable production-consumption systems through more efficient resource use and a drop in the consumption of resources. This can be achieved through:

- 1 overall waste prevention
- 2 the use of non-toxic materials and processes
- 3 the development of closed materials cycles
- 4 the development of more durable products
- 5 the development of more re-usable and recyclable products
- 6 increased re-use, recycling and recovery
- 7 the transfer of waste management costs for used products onto producers consistent with the Polluters Pay Principle (<http://www.grn.org/resources/BevEPR.html>).

Environmental legislation invokes science both in its goals and its methods and either or both may generate fierce debate. The legislator must first determine whether there are defensible scientific grounds for asserting that an environmental problem exists and then defend specific policy choices reflected in a bill that proposes to address the problem. Even if there is general agreement that an environmental problem exists, debate over the specific mechanisms of a bill may obscure its fundamental aims. An initial question considered was whether crop production, as the leading agricultural polluter, should be a higher environmental priority than animal agriculture. While this question has not been a large factor in the current debate on this issue, it is an obvious one that should be considered. First, changing production practices in the livestock industry are intensifying environmental challenges. The national trend toward fewer operations, with more animals per operation and a lower average land base (upon which crops could be grown to utilize manure), means that, in some areas, there is a

surplus of manure – more manure than can be safely applied on nearby crop land. In 1997, the US Department of Agriculture reported that:

The continued intensification of animal production systems without regard to the adequacy of the available land base for manure recycling presents a serious policy problem.

This move toward specialized farms – raising only livestock, not crops – means that an increasing number of animal feeding operations are not dependent on a particular land base but can locate anywhere that makes economic sense, taking into account access to feed supplies, processing plants, inexpensive land, etc. Secondly, the economic incentives of nutrient management are substantially different between crop production and animal agriculture. Controlling nutrient use in crop production is primarily a matter of managing fertilizer inputs, so the cost savings from reducing commercial fertilizer use are an economic incentive for better management practices. Finally, although a number of states have developed environmental regulations specifically focused on animal agriculture and many more states are considering such regulations, the rapid intensification of livestock operations in some areas of the country has out paced some states ability to enact adequate regulations (http://www.ucowr.siu.edu/updates/pdf/V113_A5.pdf).

Motor vehicles represent the single largest anthropogenic (man-made) source of air pollution in the USA. In recent years, the shift away from cars towards larger vehicles, such as sports utility vehicles (SUVs), is responsible for a reversal of years in fuel efficiency improvements to the US motor vehicle fleet. Fuel efficiency technology improvements generally have not been sufficient to compensate for the increasing popularity of SUVs and other relatively fuel-inefficient vehicles. These vehicles produce, on average, one-third more carbon dioxide per kilometer than the average passenger car. As required by the Clean Air Act (CAA), the US petroleum refining industry has responded to five major new Federal rules on motor gasoline product quality in the last 14 years or so: Phase 1 Summer Volatility (RVP) Regulation (June 1989); Phase 2 Summer Volatility Regulation (May 1992); Oxygenated Gasoline (November 1992); Reformulated Gasoline Phase 1 (December 1994); and Reformulated Gasoline Phase 2 (January 2000) (<http://www.eia.doe.gov/emeu/cabs/usenv.html>).

Canada has been one of the drivers of ISO 14001, primarily because of its significant potential impact on sustainable development. Because of its large forest industry and fisheries, Canada has been at the forefront and a champion of sustainable development industries. Much of its 'wealth' is based on its abundant natural resources and, as such, Canada has placed a high priority on the environment at federal, provincial, territorial and local levels of government. A strong commitment to ecosystem management is now a priority in most corporate Canadian overall business decision-making. Canada not only hosted the Montreal Protocol, but is also the home of the International Institute for Sustainable Development (IISD), which plays a key role in monitoring and developing programs and policies that are concerned with integrating trade and the environment (Culley, 1998).

Through the 1960s and early 1970s, it was speculated that the earth's ozone layer was being destroyed by the use of chlorofluorocarbons (CFCs). In 1985, an international agreement, known as the Vienna Convention for the Protection of the Ozone

Layer, was signed but did not impose accountability or obligations on any country. Accountability and legal requirements were finally addressed in 1987, when the Montreal Protocol on Substances that Deplete the Ozone Layer was signed by 27 countries. It was further amended in 1990 and 1992 when more than 50 additional countries signed a written agreement with its requirements. The main issues of this document are focused on the stratospheric ozone layer by three milestones:

- 1 stop employing chlorofluorocarbon (CFCs) by 1996
- 2 halons, carbon tetrachloride by 2000
- 3 methyl chloroform (trichloroethane) by 2005.

The parties to the agreement understood some CFCs have essential applications, such as medical, for which there are no known practical substitutes yet available. Since the Montreal Protocol came into effect, the atmospheric concentrations of the most important chlorofluorocarbons and related chlorinated hydrocarbons have either leveled off or decreased. Halon concentrations have continued to increase, as the halons presently stored in fire extinguishers are released, but their rate of increase has slowed and their abundance is expected to begin to decline by about 2020. Also, the concentration of the hydrochlorofluorocarbons (HCFCs) increased drastically at least partly due to the fact that for many uses CFCs (e.g. used as solvents or refrigerating agents) were substituted with HCFCs. While there have been reports of attempts by individuals to circumvent the ban, e.g. by smuggling CFCs from undeveloped to developed nations, the overall level of compliance has been high. In consequence, the Montreal Protocol has often been called the most successful international environmental agreement to date. Unfortunately, the HCFCs and hydrofluorocarbons, or HFCs, are now thought to contribute to anthropogenic global warming. On a molecule-for-molecule basis, these compounds are up to 10 000 times more potent greenhouse gases than carbon dioxide and their intensive use significantly increases the danger that human activity will change the climate. The Montreal Protocol currently calls for a complete phaseout of HCFCs by 2030, but does not place any restriction on HFCs (Culley, 1998; http://en.wikipedia.org/wiki/Montreal_Protocol).

US legislation for environment

According to the Federal Insecticide, Fungicide and Rodenticide Act (FIFRA) of 1947, the term 'pesticide' means:

- 1 any substance or mixture of substances intended for preventing, destroying, repelling, or mitigating any pest
- 2 any substance or mixture of substances intended for use as a plant regulator, defoliant or desiccant
- 3 any nitrogen stabilizer,

except that the term 'pesticide' shall not include any article that is a 'new animal drug', that has been determined by the Secretary of Health and Human Services not to be a new animal drug by a regulation establishing conditions of use for the article, or that is an animal feed within the meaning of this section or containing a new animal drug. The term 'pesticide' does not include liquid chemical sterilant products (including any sterilant or subordinate disinfectant claims on such products) for use on a critical or semi-critical device. A pesticide is misbranded if:

- 1 its labeling bears any statement, design, or graphic representation relative thereto or to its ingredients which is false or misleading in any particular
- 2 it is contained in a package or other container or wrapping which does not conform to the standards established by the Administrator
- 3 it is an imitation of, or is offered for sale under the name of, another pesticide
- 4 its label does not bear the registration number assigned under this section of this title to each establishment in which it was produced
- 5 the label does not contain a warning or caution statement which may be necessary and if complied with this Act
- 6 in the case of a pesticide not registered in accordance with this section and intended for export, the label does not contain, in words prominently placed thereon with such conspicuousness (as compared with other words, statements, designs, or graphic matter in the labeling) as to render it likely to be noted by the ordinary individual under customary conditions of purchase and use, the following: 'Not Registered for Use in the United States of America'.

A pesticide which is not registered with the Administrator may be transferred if:

- 1 the transfer is from one registered establishment to another registered establishment operated by the same producer solely for packaging at the second establishment or for use as a constituent part of another pesticide produced at the second establishment
- 2 the transfer is pursuant to and in accordance with the requirements of an experimental use permit.

The Administrator shall register a pesticide if the Administrator determines that, when considered with any restrictions imposed under this section:

- 1 its composition is such as to warrant the proposed claims for it
- 2 its labeling and other material required to be submitted comply with the requirements of this subchapter
- 3 it will perform its intended function without unreasonable adverse effects on the environment
- 4 when used in accordance with widespread and commonly recognized practice it will not generally cause unreasonable adverse effects on the environment.

In order to carry out the policy set forth in the National Environmental Policy Act (NEPA) of 1969, it is the continuing responsibility of the Federal Government to use

all practicable means, consistent with other essential considerations of national policy, to improve and coordinate Federal plans, functions, programs and resources to the end that the Nation may:

- 1 fulfill the responsibilities of each generation as trustee of the environment for succeeding generations
- 2 assure for all Americans safe, healthful, productive and esthetically and culturally pleasing surroundings
- 3 attain the widest range of beneficial uses of the environment without degradation, risk to health or safety, or other undesirable and unintended consequences
- 4 preserve important historic, cultural and natural aspects of our national heritage and maintain, wherever possible, an environment which supports diversity and variety of individual choice
- 5 achieve a balance between population and resource use which will permit high standards of living and a wide sharing of life's amenities
- 6 enhance the quality of renewable resources and approach the maximum attainable recycling of resources.

The Congress recognizes that each person should enjoy a healthful environment and that each person has a responsibility to contribute to the preservation and enhancement of the environment. All agencies of the Federal Government shall:

- 1 utilize a systematic, interdisciplinary approach which will insure the integrated use of the natural and social sciences and the environmental design arts in planning and in decision-making which may have an impact on man's environment
- 2 identify and develop methods and procedures, in consultation with the Council on Environmental Quality established by title II of this Act, which will ensure that presently unquantified environmental amenities and values may be given appropriate consideration in decision-making along with economic and technical considerations
- 3 include in every recommendation or report on proposals for legislation and other major Federal actions significantly affecting the quality of the human environment, a detailed statement by the responsible official on:
 - i the environmental impact of the proposed action
 - ii any adverse environmental effects which cannot be avoided should the proposal be implemented
 - iii alternatives to the proposed action
 - iv the relationship between local short-term uses of man's environment and the maintenance and enhancement of long-term productivity
 - v any irreversible and irretrievable commitments of resources which would be involved in the proposed action should it be implemented.

In general, the Occupational Safety and Health Act of 1970 (OSH Act) covers all employers and their employees in the 50 states, the District of Columbia, Puerto Rico and other US territories. Coverage is provided either directly by the federal Occupational Safety and Health Administration (OSHA) or by an OSHA-approved state job safety and health

plan. Employees of the US Postal Service also are covered. The Act defines an employer as any 'person engaged in a business affecting commerce that has employees, but does not include the United States or any state or political subdivision of a State'. Therefore, the Act applies to employers and employees in such varied fields as manufacturing, construction, longshoring, agriculture, law and medicine, charity and disaster relief, organized labor and private education. The Act establishes a separate program for federal government employees and extends coverage to state and local government employees only through the states with OSHA-approved plans. The Act does not cover self-employed persons, farms which employ only immediate members of the farmer's family, working conditions for which other federal agencies, operating under the authority of other federal laws, regulate worker safety. This category includes most working conditions in mining, nuclear energy and nuclear weapons manufacture and many aspects of the transportation industries and employees of state and local governments, unless they are in one of the states operating an OSHA-approved state plan. The Act assigns OSHA two regulatory functions: setting standards and conducting inspections to ensure that employers are providing safe and healthful workplaces. OSHA standards may require that employers adopt certain practices, means, methods or processes reasonably necessary and appropriate to protect workers on the job. Employers must become familiar with the standards applicable to their establishments and eliminate hazards. The Voluntary Protection Programs (VPP) are an OSHA initiative aimed at extending worker protection beyond the minimum required by OSHA standards. The VPP is designed to:

- 1 recognize the outstanding achievements of those who have successfully incorporated comprehensive safety and health programs into their total management systems
- 2 motivate others to achieve excellent safety and health results in the same outstanding way
- 3 establish a relationship between employers, employees and OSHA that is based on cooperation rather than coercion.

The Clean Air Act (CAA) of 1970 contains titles that: strengthen measures for attaining air quality standards (Title I); set forth provisions relating to mobile sources (Title II); expand the regulation of hazardous air pollutants (Title III); require substantial reductions in power plant emissions for control of acid rain (Title IV); establish operating permits for all major sources of air pollution (Title V); establish provisions for stratospheric ozone protection (Title VI); and expand enforcement powers and penalties (Title VII). The original 1970 CAA authorized EPA to establish National Ambient Air Quality Standards (NAAQS) to limit levels of pollutants in the air. EPA has promulgated NAAQS for six criteria pollutants: sulfur dioxide (SO₂), nitrogen dioxide (NO₂), carbon monoxide (CO), ozone, lead and particulate matter (PM-10). All areas of the USA must maintain ambient levels of these pollutants below the ceilings established by the NAAQS; any area that does not meet these standards is a 'non-attainment' area (NAA). Under previous law, 'major sources' were those with the potential to emit

more than 100 tons per year (tpy). The CAA Amendments reduced the size of plants subject to permitting and stringent retrofitting or offsetting requirements:

- 1 in serious ozone NAAs, 'major sources' include those with the potential to emit more than 50 tpy of volatile organic compounds (VOCs). In severe ozone NAAs, 'major sources' include those that emit 25 tpy or, in extreme areas, 10 tpy
- 2 for serious CO NAAs a 'major source' is now one that emits 50 tpy
- 3 for serious PM-10 NAAs a 'major source' is now one that emits 70 tpy.

The new permit program will be fee-based and federal facilities are explicitly required to pay a fee or charge imposed by a state or local agency to defray the costs of its air-pollution regulatory program. The statute sets minimum rates for such fees at \$25 per ton of each regulated pollutant, up to 4000 tpy. The EPA Administrator may set other amounts to reflect adequately reasonable costs of the permit program. The following sources must have a permit to operate: major Hazardous Air Pollutant (HAP) sources, major sources under NAAQS, all affected sources under Title IV and all sources subject to NSPS.

The Clean Water Act (CWA) of 1972, formerly known as the Federal Water Pollution Control Act, intended to restore and maintain the chemical, physical and biological integrity of the Nation's waters. To accomplish that objective, the act aimed to attain a level of water quality that 'provides for the protection and propagation of fish, shellfish and wildlife and provides for recreation in and on the water' by 1983 and to eliminate the discharge of pollutants into navigable waters by 1985. The CWA has five main elements:

- 1 a system of minimum national effluent standards for each industry
- 2 water quality standards
- 3 a discharge permit program that translates these standards into enforceable limits
- 4 provisions for special problems such as toxic chemicals and oil spills
- 5 a revolving construction loan program (formerly a grant program) for publicly-owned treatment works (POTWs).

The CWA requires the EPA to establish effluent limitations for the amounts of specific pollutants that may be discharged by municipal sewage plants and industrial facilities. The two-step approach to setting the standards includes:

- 1 establishing a nationwide, base-level treatment through an assessment of what is technologically and economically achievable for a particular industry
- 2 requiring more stringent levels of treatment for specific plants if necessary to achieve water quality objectives for the particular body of water into which that plant discharges.

For example, EPA sets limits based on water quality to control pollution in waters designated by the states for drinking, swimming or fishing. The primary method by which the act imposes limitations on pollutant discharges is the nationwide permit program

established under Section 402 and referred to as the National Pollutant Discharge Elimination System (NPDES). Under the NPDES program, any person responsible for the discharge of a pollutant or pollutants into any waters of the USA from any point source must apply for and obtain a permit. For industrial facilities that existed before July 1, 1977, the 'best conventional technology' must be applied to the discharge stream for conventional pollutants. For facilities built after July 1, 1977, so-called 'new' facilities, the National Standards of Performance apply. When either an existing or new facility discharges toxic pollutants, more stringent controls are required. The regulations for toxics are based on 'best available technology economically achievable'. In all cases, NPDES permits can be made even more stringent than the above standards if the specific water body in question requires lower discharges of pollutants to meet water quality standards. Facilities that discharge to a municipal or publicly-owned wastewater system do not have to obtain an NPDES permit, but they must follow the pretreatment regulations. These pretreatment regulations require that industrial dischargers remove or treat all pollutants that could pass through the municipal system untreated or could adversely affect the performance of the municipal system. Toxic pollutants are the primary concern of these regulations. Note that, quite apart from the CWA, states may, under certain circumstances, exercise a limited role in the regulation of these materials. Until this section was added to the AEA in 1959, states had no role in the licensing and regulation of source, by-product or special nuclear materials.

Following the Marine Protection, Research and Sanctuaries Act (MPRSA) of 1972, in the case of dredged material disposal sites, the Administrator, in conjunction with the Secretary, shall develop a site management plan for each site designated pursuant to this section. In developing such plans, the Administrator and the Secretary shall provide opportunity for public comment. Such plans shall include, but not be limited to:

- 1 a baseline assessment of conditions at the site
- 2 a program for monitoring the site
- 3 special management conditions or practices to be implemented at each site that are necessary for protection of the environment
- 4 consideration of the quantity of the material to be disposed of at the site and the presence, nature and bioavailability of the contaminants in the material
- 5 consideration of the anticipated use of the site over the long term, including the anticipated closure date for the site, if applicable, and any need for management of the site after the closure of the site
- 6 a schedule for review and revision of the plan (which shall not be reviewed and revised less frequently than 10 years after adoption of the plan and every 10 years thereafter).

An agreement shall be a compliance agreement for purposes of this section only if:

- 1 it includes a plan negotiated by the person, the State in which the person is located and the Administrator that will, in the opinion of the Administrator, if adhered to by the

person in good faith, result in the phasing out and termination of ocean dumping and transportation for the purpose of ocean dumping, of sewage sludge and industrial waste by such person by not later than December 31, 1991, through the design, construction and full implementation of an alternative system for the management of sewage sludge and industrial waste transported or dumped by the person

- 2 it includes a schedule
- 3 it requires the person to notify in a timely manner the Administrator and the Governor of the State of any problems the person has in complying with the schedule referred to this Act
- 4 it requires the Administrator and the Governor of the State to evaluate on an ongoing basis the compliance of the person with the schedule referred to this Act
- 5 it requires the person to pay in accordance with this section all fees and penalties the person is liable for under this section
- 6 it authorizes the person to use interim measures before completion of the alternative system referred to in this section.

For the purpose of the Coastal Zone Management Act (CZMA) of 1972, the term 'coastal zone' means the coastal waters (including the lands therein and there under) and the adjacent shorelands (including the waters therein and there under), strongly influenced by each other and in proximity to the shorelines of the several coastal states and includes islands, transitional and intertidal areas, salt marshes, wetlands and beaches. The zone extends in Great Lakes waters to the international boundary between the USA and Canada and, in other areas, seaward to the outer limit of State title and ownership under the Submerged Lands Act, the Puerto Rican Federal Relations Act, the Covenant to Establish a Commonwealth of the Northern Mariana Islands in Political Union with the USA. The zone extends inland from the shorelines only to the extent necessary to control shorelands, the uses of which have a direct and significant impact on the coastal waters, and to control those geographical areas which are likely to be affected by or vulnerable to sea level rise. Excluded from the coastal zone are lands the use of which is by law subject solely to the discretion of or which is held in trust by the Federal Government, its officers or agents.

For the purposes of the Endangered Species Act (ESA) of 1973, the term 'alternative courses of action' means all alternatives and thus is not limited to original project objectives and agency jurisdiction, the term 'commercial activity' means all activities of industry and trade, including, but not limited to, the buying or selling of commodities and activities conducted for the purpose of facilitating such buying and selling, provided, however, that it does not include exhibitions of commodities by museums or similar cultural or historical organizations and the terms 'conserve', 'conserving' and 'conservation' mean to use and the use of all methods and procedures which are necessary to bring any endangered species or threatened species to the point at which the measures provided pursuant to this Act are no longer necessary. Such methods and procedures include, but are not limited to, all activities associated with scientific resources management such as research, census, law enforcement, habitat acquisition and maintenance, propagation, live trapping and transplantation and, in the extraordinary case where population pressures within a given ecosystem cannot be otherwise

relieved, may include regulated taking. In carrying out the program authorized by this Act, the Secretary shall cooperate to the maximum extent practicable with the States. Such cooperation shall include consultation with the States concerned before acquiring any land or water, or interest therein, for the purpose of conserving any endangered species or threatened species. The Secretary shall:

- 1 conduct, at least once every five years, a review of all species included in a list which is published and which is in effect at the time of such review
- 2 determine on the basis of such review whether any such species should:
 - i be removed from such list
 - ii be changed in status from an endangered species to a threatened species
 - iii be changed in status from a threatened species to an endangered species.

According to the Safe Drinking Water Act (SDWA), the term 'primary drinking water regulation' means a regulation which:

- 1 applies to public water systems
- 2 specifies contaminants which, in the judgment of the Administrator, may have any adverse effect on the health of persons
- 3 specifies for each such contaminant either a maximum contaminant level, if, in the judgment of the Administrator, it is economically and technologically feasible to ascertain the level of such contaminant in water in public water systems or if, in the judgment of the Administrator, it is not economically or technologically feasible to so ascertain the level of such contaminant, each treatment technique known to the Administrator which leads to a reduction in the level of such contaminant sufficient to satisfy the requirements of this section
- 4 contains criteria and procedures to assure a supply of drinking water which dependably complies with such maximum contaminant levels; including accepted methods for quality control and testing procedures to insure compliance with such levels and to insure proper operation and maintenance of the system and requirements as to the minimum quality of water which may be taken into the system and siting for new facilities for public water systems.

At any time after promulgation of a regulation referred to in this paragraph, the Administrator may add equally effective quality control and testing procedures by guidance published in the Federal Register. Such procedures shall be treated as an alternative for public water systems to the quality control and testing procedures listed in the regulation. For purposes of this Act, a State has primary enforcement responsibility for public water systems during any period for which the Administrator determines (pursuant to regulations prescribed under this section) that such State:

- 1 has adopted drinking water regulations that are no less stringent than the national primary drinking water regulations promulgated by the Administrator under this

section not later than 2 years after the date on which the regulations are promulgated by the Administrator, except that the Administrator may provide for an extension of not more than 2 years if, after submission and review of appropriate, adequate documentation from the State, the Administrator determines that the extension is necessary and justified

- 2 has adopted and is implementing adequate procedures for the enforcement of such State regulations, including conducting such monitoring and making such inspections as the Administrator may require by regulation
- 3 will keep such records and make such reports with respect to its activities under paragraphs (1) and (2) as the Administrator may require by regulation
- 4 if it permits variances or exemptions, or both, from the requirements of its drinking water regulations which meet the requirements of paragraph (1), permits such variances and exemptions under conditions and in a manner which is not less stringent than the conditions under and the manner in which variances and exemptions may be granted under this section of this title
- 5 has adopted and can implement an adequate plan for the provision of safe drinking water under emergency circumstances including earthquakes, floods, hurricanes and other natural disasters, as appropriate
- 6 has adopted authority for administrative penalties (unless the constitution of the State prohibits the adoption of the authority) in a maximum amount:
 - i in the case of a system serving a population of more than 10 000, that is not less than \$1000 per day per violation
 - ii in the case of any other system, that is adequate to ensure compliance (as determined by the State); except that a State may establish a maximum limitation on the total amount of administrative penalties that may be imposed on a public water system per violation.

The Hazardous Materials Transportation Act (HMTA) of 1974 specified that a motor carrier shall determine its base state designation in the following manner:

- 1 a motor carrier that has its principal place of business in this state shall designate this state as its base state
- 2 a motor carrier that has its principal place of business outside of this state shall determine its base state designation by the highest number of hazardous materials miles traveled among the states participating in the uniform program. A motor carrier shall determine its percentage of transportation in this state by dividing the number of miles traveled in this state under the international registration plan during the previous year by the number of miles it traveled nationwide under the international registration plan. If a motor carrier operated only in this state, its percentage is 100%. If a motor carrier is not registered in the international registration plan, the motor carrier shall calculate the number of miles traveled using the method in the international registration plan. If a motor carrier operates more than one fleet under the international registration plan, the motor carrier may calculate each fleet's contribution to the motor carrier's total fee separately. A motor carrier who operated in another state under a reciprocal agreement with that state shall

include the miles operated under the agreement as miles traveled in this state in calculating mileage under this section. A motor carrier with a valid permit shall annually certify that its current operations are not substantially different from its operations on the date the motor carrier obtained its permit and shall annually certify its compliance with all applicable laws and regulations in its application for renewal.

The objectives of the Resource Conservation and Recovery Act (RCRA) of 1976 are to protect health and the environment and to conserve valuable material and energy resources by measures which include: providing technical and financial assistance to state and local governments and interstate agencies for the development of solid waste management plans (including resource recovery and resource conservation) to promote improved solid waste management techniques; prohibiting open dumping on land; assuring that hazardous waste is managed in a manner that protects human health and the environment; minimizing the generation and land disposal of hazardous waste by encouraging process substitution, materials recovery, properly conducted recycling and re-use and treatment; establishing a viable federal-state partnership to carry out the purposes of the Act. It is national policy that, wherever feasible, the generation of hazardous waste is to be reduced or eliminated as expeditiously as possible. Waste that is generated should be treated, stored or disposed of as to minimize the present and future threat to human health and the environment. The Act directs the Administrator to adopt regulations for hazardous waste generators as necessary to protect human health and the environment, including requirements that generators use a manifest system to ensure that waste being transported is sent to authorized facilities. Generators must maintain certain records, label and use appropriate containers for the waste they generate and have waste minimization programs in place. The Act requires the Administrator to adopt performance standards for hazardous waste treatment, storage or disposal (TSD) facilities. Regulations must include standards for the location, design and construction of the facilities and for operating methods and practices. Owners and operators of TSD facilities are required to obtain permits and must be able to demonstrate financial responsibility for meeting facility closure and corrective action requirements. RCRA prohibits the disposal of most hazardous wastes in landfills unless strict treatment standards are met. Groundwater monitoring is required on an ongoing basis at landfills, surface impoundments and certain other permitted TSD facilities. Corrective action is required at all permitted facilities when contamination is found. Under RCRA, any person may bring a citizen suit in federal district court against anyone who is allegedly violating the Act or a regulation or permit issued under the Act, as well as against anyone contributing to a past or present handling of hazardous waste that may present an imminent and substantial endangerment to health or the environment, with a 60-day notice to the violator. In addition, the Administrator, upon receipt of evidence that past or present handling, storage, treatment, transportation or disposal of a solid waste or hazardous waste may present an imminent and substantial endangerment to health or the environment, may order the offending person to restrain from that action, or take such other action as may be necessary, or both.

Following the Toxic Substances Control Act (TSCA), the term 'chemical substance' means any organic or inorganic substance of a particular molecular identity, including:

- 1 any combination of such substances occurring in whole or in part as a result of a chemical reaction or occurring in nature
- 2 any element or uncombined radical.

Such term does not include:

- 1 any mixture
- 2 any pesticide when manufactured, processed or distributed in commerce for use as a pesticide
- 3 tobacco or any tobacco product
- 4 any source material, special nuclear material or by-product material
- 5 any food, food additive, drug, cosmetic or device when manufactured, processed or distributed in commerce for use as a food, food additive, drug, cosmetic or device.

Within six months after 1 January 1977, the Administrator shall promulgate rules to:

- 1 prescribe methods for the disposal of polychlorinated biphenyls
- 2 require polychlorinated biphenyls to be marked with clear and adequate warnings, and instructions with respect to their processing, distribution in commerce, use or disposal or with respect to any combination of such activities.

One year after January 1, 1977, no person may manufacture, process or distribute in commerce or use any polychlorinated biphenyl in any manner other than in a totally enclosed manner. The Administrator may, by rule, authorize the manufacture, processing, distribution in commerce or use (or any combination of such activities) of any polychlorinated biphenyl in a manner other than in a totally enclosed manner if the Administrator finds that such manufacture, processing, distribution in commerce or use (or combination of such activities) will not present an unreasonable risk of injury to health or the environment. For the purposes of this paragraph, the term 'totally enclosed manner' means any manner which will ensure that any exposure of human beings or the environment to a polychlorinated biphenyl will be insignificant as determined by the Administrator by rule. No person may manufacture any polychlorinated biphenyl after two years after January 1, 1977 and no person may process or distribute in commerce any polychlorinated biphenyl after two and one-half years after such date. The Administrator may grant by rule such an exemption if the Administrator finds that:

- 1 an unreasonable risk of injury to health or environment would not result
- 2 good faith efforts have been made to develop a chemical substance which does not present an unreasonable risk of injury to health or the environment and which may be substituted for such polychlorinated biphenyl.

An exemption granted under this sub-paragraph shall be subject to such terms and conditions as the Administrator may prescribe and shall be in effect for such period (but not more than one year from the date it is granted) as the Administrator may prescribe. The term 'imminently hazardous chemical substance or mixture' means a chemical substance or mixture which presents an imminent and unreasonable risk of serious or widespread injury to health or the environment. Such a risk to health or the environment shall be considered imminent if it is shown that the manufacture, processing, distribution in commerce, use or disposal of the chemical substance or mixture, or that any combination of such activities, is likely to result in such injury to health or the environment before a final rule can protect against such risk.

The purposes of the Surface Mining Control and Reclamation Act (SMCRA) of 1977 are to establish a nationwide program to protect society and the environment from the adverse effects of surface coal mining operations; assure that surface mining operations are not conducted where reclamation is not feasible and are conducted so as to protect the environment; assure that adequate procedures are undertaken to reclaim surface areas as contemporaneously as possible with the surface coal mining operations; strike a balance between protection of the environment and agricultural productivity and the nation's need for coal as an essential source of energy; assist the states in developing and implementing a program to achieve the purposes of the Act; promote the reclamation of mined areas left without adequate reclamation. The Act creates the Abandoned Mine Reclamation Fund (Fund) to be administered by the Secretary. Among other purposes, the Fund may be used to reclaim and restore land and water resources adversely affected by past coal mining, including reclamation and restoration of abandoned surface mine areas; prevent and control water pollution caused by coal mine drainage; prevent and control coal mine subsidence; seal and fill abandoned deep mine entries and voids; acquire and fill voids and seal tunnels, shafts and entryways. The Act directs that Fund expenditures on eligible lands and waters reflect stated priorities in a given order, including the restoration of land and water resources and the environment degraded by coal mining practices. Restoration includes measures to conserve and develop soil, water, woodland, fish and wildlife, recreation sources and agricultural productivity. The Act requires annual reports to Congress on operations under the Fund and recommendations for future Fund uses. Lands and water eligible for reclamation or drainage abatement expenditures are those that were mined for coal or affected by mining, wastebanks, coal processing or other coal mining processes and abandoned or left in an inadequate reclamation status prior to enactment of the Act. The Act directs the Secretary to maintain an inventory of eligible lands and waters.

The Uranium Mill Tailings Radiation Control Act (UMTRCA) of 1978 gave the US Department of Energy (DOE) the responsibility of stabilizing, disposing and controlling uranium mill tailings and other contaminated material at twenty-four uranium mill processing sites located across ten states and at approximately 5200 associated properties. In the 1950s and 1960s, private firms processed most uranium ore mined in the USA. After uranium mining came under federal control, companies abandoned their mill operations, leaving behind materials with potential long-term health hazards. These mills contained low-level radioactive wastes and other hazardous substances that eventually migrated to

surrounding soil, groundwater, surface water and emitted radon gas. Under the Act, the DOE established the Uranium Mill Tailings Remedial Action (UMTRA) Project to monitor the cleanup of uranium mill tailings. The UMTRA gave the Nuclear Regulatory Commission (NRC) regulatory authority over the cleanup and licensing of mill tailing facilities at sites under NRC license. The US Environmental Protection Agency (EPA) had the task of developing cleanup strategies and recording standards for mills. The UMTRA used on-site disposal methods for eleven of the mills, while excavating and disposing of the wastes found at the remaining thirteen sites to remote off-site disposal locations owned by the DOE.

The Comprehensive Environmental Response, Compensation and Liability Act (CERCLA), commonly known as Superfund, was enacted by Congress in 1980. This law created a tax on the chemical and petroleum industries and provided broad Federal authority to respond directly to releases or threatened releases of hazardous substances that may endanger public health or the environment. Over five years, \$1.6 billion was collected and the tax went to a trust fund for cleaning up abandoned or uncontrolled hazardous waste sites. CERCLA:

- 1 established prohibitions and requirements concerning closed and abandoned hazardous waste sites
- 2 provided for liability of persons responsible for releases of hazardous waste at these sites
- 3 established a trust fund to provide for cleanup when no responsible party could be identified.

The law authorizes two kinds of response actions:

- 1 short-term removals, where actions may be taken to address releases or threatened releases requiring prompt response
- 2 long-term remedial response actions, that permanently and significantly reduce the dangers associated with releases or threats of releases of hazardous substances that are serious, but not immediately life threatening.

In the Low Level Radioactive Policy Act (LLRPA) of 1980, the purpose of this section was:

- 1 to recognize the interests of the States in the peaceful uses of atomic energy and to clarify the respective responsibilities under this chapter of the States and the Commission with respect to the regulation of by-product, source and special nuclear materials
- 2 to recognize the need, and establish programs, for cooperation between the States and the Commission with respect to control of radiation hazards associated with use of such materials
- 3 to promote an orderly regulatory pattern between the Commission and State governments with respect to nuclear development and use and regulation of by-product, source and special nuclear materials

- 4 to establish procedures and criteria for discontinuance of certain of the Commission's regulatory responsibilities with respect to by-product, source and special nuclear materials and the assumption thereof by the States
- 5 to provide for coordination of the development of radiation standards for the guidance of Federal agencies and cooperation with the States
- 6 to recognize that, as the States improve their capabilities to regulate effectively such materials, additional legislation may be desirable.

The Commission is authorized and directed to cooperate with the States in the formulation of standards for protection against hazards of radiation to assure that State and Commission programs for protection against hazards of radiation will be coordinated and compatible. The Commission, upon its own motion or upon request of the Governor of any State, may, after notifying the Governor, temporarily suspend all or part of its agreement with the State without notice or hearing if, in the judgment of the Commission:

- 1 an emergency situation exists with respect to any material covered by such an agreement creating danger which requires immediate action to protect the health or safety of persons either within or outside the State
- 2 the State has failed to take steps necessary to contain or eliminate the cause of the danger within a reasonable time after the situation arose.

A temporary suspension under this paragraph shall remain in effect only for such time as the emergency situation exists and shall authorize the Commission to exercise its authority only to the extent necessary to contain or eliminate the danger.

The Superfund Amendments and Reauthorization Act (SARA) of 1986 Title III provides funding for training in emergency planning, preparedness, mitigation, response and recovery capabilities associated with hazardous chemicals. Individuals who would be eligible for this training include public officials, fire and police personnel, medical personnel, first responders and other tribal response and planning personnel. Funding is available to federally recognized Tribal Nations. Title III of SARA addresses concerns about emergency preparedness for hazardous chemicals. It establishes requirements for federal, Tribal/State, local governments and industry regarding emergency planning and 'community-right-to-know' reporting on hazardous and toxic chemicals. This legislation emphasizes:

- 1 helping communities meet their responsibilities in preparing to handle chemical emergencies
- 2 increasing public knowledge and access to information on hazardous chemicals present in their communities.

A program narrative that includes an acceptable work plan with the following elements:

- 1 narrative description of requested background and proposed program information, including a description of the overall long-range training objective(s)
- 2 titles of courses/activities to be funded

- 3 projected number of participants and level of training they will receive
- 4 percentage of the long-range objective(s) that will be attained by this funding
- 5 prioritization of training if less than 100% of grant application is approved
- 6 activities other than training for which funds will be expended
- 7 documentation to support the 20% matching funds requirement.

The objects of Soil Conservation and Land Care Act (SCLCA) of 1989 are as follows:

- 1 to recognize that the land and its soil, vegetation and water constitute the most important natural resource of the State and that conservation of that resource is crucial to the welfare of the people of this State
- 2 to recognize that degradation of the land has occurred to a significant extent and that some degradation is still occurring and that Government, industry and the community at large must work together to prevent or minimize further degradation and rehabilitate degraded land
- 3 to ensure that conservation of land becomes an integral part of land management practice and that land is used within its capability
- 4 to establish a system ensuring the regular and effective monitoring and evaluation of the condition of the land, the early identification of degradation of the land and the causes of that degradation, the development, implementation and enforcement of plans for preventing or minimizing further degradation and for rehabilitating degraded land
- 5 to involve the community as widely as possible in the administration of this Act and in programs designed to conserve or rehabilitate land.

The Minister, the Council, the boards, the Conservator and all other bodies and persons involved in the administration of this Act must, in carrying out that administration, act consistently with and seek to further the objects of this Act. The functions of the Council are as follows:

- 1 to advise the Minister on the administration of this Act and the policies that should govern that administration
- 2 to monitor and evaluate the condition of the land of the State and advise the Minister on the extent of land degradation and the economic and environmental implications of that degradation
- 3 to advise the Minister on the priorities to be accorded to land degradation research programs, land care programs and other projects or programs for the conservation or rehabilitation of land
- 4 to develop sound strategies for the conservation and rehabilitation of land
- 5 to disseminate information on and promote community awareness of issues relating to conservation and rehabilitation of land and, in particular, to promote the principles that land must be used within its capability and forward planning on that basis must become standard land management practice

- 6 to monitor the operation of this Act and report to the Minister on any problems identified by the Council with the Act or its administration
- 7 to perform the other functions (including the approval of district plans and three year board programs) assigned to the Council by or under this Act or by the Minister.

The Council may require a board to investigate and report to the Council on any matters relating to the administration of this Act within the board's district. The position of Soil Conservator established under the repealed Act continues in existence. The Conservator is a Public Service employee. It is an essential requirement for appointment to the position of Soil Conservator that the appointee has had experience in the field of soil conservation or land management.

The Oil Pollution Act (OPA) was signed into law in August 1990, largely in response to rising public concern following the 'Exxon Valdez' incident. The OPA improved the nation's ability to prevent and respond to oil spills by establishing provisions that expand the Federal government's ability and provide the money and resources necessary to respond to oil spills. The OPA also created the national Oil Spill Liability Trust Fund, which is available to provide up to one billion dollars per spill incident. In addition, the OPA provided new requirements for contingency planning both by government and industry. The National Oil and Hazardous Substances Pollution Contingency Plan (NCP) has been expanded in a three-tiered approach: the Federal government is required to direct all public and private response efforts for certain types of spill events; Area Committees – composed of federal, state and local government officials – must develop detailed, location-specific Area Contingency Plans; and owners or operators of vessels and certain facilities that pose a serious threat to the environment must prepare their own Facility Response Plans. Finally, the OPA increased penalties for regulatory non-compliance, broadened the response and enforcement authorities of the Federal government and preserved State authority to establish law governing oil spill prevention and response.

According to the Pollution Prevention Act (PPA) of 1990, the term 'source reduction' means any practice which:

- 1 reduces the amount of any hazardous substance, pollutant or contaminant entering any waste stream or otherwise released into the environment (including fugitive emissions) prior to recycling, treatment or disposal
- 2 reduces the hazards to public health and the environment associated with the release of such substances, pollutants or contaminants.

The term includes equipment or technology modifications, process or procedure modifications, reformulation or redesign of products, substitution of raw materials and improvements in housekeeping, maintenance, training or inventory control. The Administrator shall establish a Source Reduction Clearinghouse to compile information, including a computer database which contains information on management,

technical and operational approaches to source reduction. The Administrator shall use the clearinghouse to:

- 1 serve as a center for source reduction technology transfer
- 2 mount active outreach and education programs by the States to further the adoption of source reduction technologies
- 3 collect and compile information reported by States receiving grants under this section on the operation and success of State source reduction programs.

The Administrator shall make available to the public such information on source reduction as is gathered pursuant to this chapter and any other pertinent information and analysis regarding source reduction as may be available to the Administrator. The data base shall permit entry and retrieval of information to any person.

The Federal Facility Compliance Act (FFCA) of 1992 made clear that the report shall include the following:

- 1 a description of each type of mixed waste at each Department of Energy facility in each State, including, at a minimum, the name of the waste stream
- 2 the amount of each type of mixed waste currently stored at each Department of Energy facility in each State, set forth separately by mixed waste that is not subject to such prohibition requirements
- 3 an estimate of the amount of each type of mixed waste the Department expects to generate in the next 5 years at each Department of Energy facility in each State
- 4 a description of any waste minimization actions the Department has implemented at each Department of Energy facility in each State for each mixed waste stream
- 5 the EPA hazardous waste code for each type of mixed waste containing waste that has been characterized at each Department of Energy facility in each State
- 6 an inventory of each type of waste that has not been characterized by sampling and analysis at each Department of Energy facility in each State
- 7 the basis for the Department's determination of the applicable hazardous waste code for each type of mixed waste at each Department of Energy facility and a description of whether the determination is based on sampling and analysis conducted on the waste or on the basis of process knowledge
- 8 a description of the source of each type of mixed waste at each Department of Energy facility in each State
- 9 the land disposal prohibition treatment technology or technologies specified for the hazardous waste component of each type of mixed waste at each Department of Energy facility in each State
- 10 a statement of whether and how the radionuclide content of the waste alters or affects use of the technologies described in this Act.

The Task Force shall:

- 1 identify regulations developed pursuant Federal environmental laws which pose significant compliance problems for small towns

- 2 identify means to improve the working relationship between the Environmental Protection Agency (hereafter referred to as the Agency) and small towns
- 3 review proposed regulations for the protection of the environmental and public health and suggest revisions that could improve the ability of small towns to comply with such regulations
- 4 identify means to promote regionalization of environmental treatment systems and infrastructure serving small towns to improve the economic condition of such systems and infrastructure
- 5 provide such other assistance to the Administrator as the Administrator deems appropriate.

Following the Nuclear Waste Policy Act, the term 'high-level radioactive waste' means:

- 1 the highly radioactive material resulting from the reprocessing of spent nuclear fuel, including liquid waste produced directly in reprocessing and any solid material derived from such liquid waste that contains fission products in sufficient concentrations
- 2 other highly radioactive material that the Commission, consistent with existing law, determines by rule requires permanent isolation.

The Congress finds that:

- 1 radioactive waste creates potential risks and requires safe and environmentally acceptable methods of disposal
- 2 a national problem has been created by the accumulation of spent nuclear fuel from nuclear reactors and radioactive waste from reprocessing of spent nuclear fuel, activities related to medical research, diagnosis and treatment and other sources
- 3 Federal efforts during the past 30 years to devise a permanent solution to the problems of civilian radioactive waste disposal have not been adequate
- 4 while the Federal government has the responsibility to provide for the permanent disposal of high-level radioactive waste and such spent nuclear fuel as may be disposed of in order to protect the public health and safety and the environment, the costs of such disposal should be the responsibility of the generators and owners of such waste and spent fuel
- 5 the generators and owners of high-level radioactive waste and spent nuclear fuel have the primary responsibility to provide for, and the responsibility to pay the costs of, the interim storage of such waste and spent fuel until such waste and spent fuel is accepted by the Secretary of Energy in accordance with the provisions of this Act
- 6 State and public participation in the planning and development of repositories is essential in order to promote public confidence in the safety of disposal of such waste and spent fuel
- 7 high-level radioactive waste and spent nuclear fuel have become major subjects of public concern, and appropriate precautions must be taken to ensure that such waste and spent fuel do not adversely affect the public health and safety and the environment for this or future generations.

The Secretary, the Commission and other authorized Federal officials shall each take such actions as such official considers necessary to encourage and expedite the effective use of available storage, and necessary additional storage, at the site of each civilian nuclear power reactor consistent with:

- 1 the protection of the public health and safety and the environment
- 2 economic considerations
- 3 continued operation of such reactor
- 4 any applicable provisions of law
- 5 the views of the population surrounding such reactor.

Transportation of spent nuclear fuel under section 136(a) shall be subject to licensing and regulation by the Commission and by the Secretary of Transportation as provided for transportation of commercial spent nuclear fuel under existing law. The Secretary, in providing for the transportation of spent nuclear fuel under this Act shall utilize by contract private industry to the fullest extent possible in each aspect of such transportation. The Secretary shall use direct Federal services for such transportation only upon a determination of the Secretary of Transportation, in consultation with the Secretary, that private industry is unable or unwilling to provide such transportation services at reasonable cost.

The Clean Smokestacks Act of 2002 requires power companies to reduce their smog- and haze-forming emissions by approximately three-fourths over the next decade. It is hoped this landmark for multi-pollutant legislation will set the standard for similar actions by the Federal government and other states. Under the act, coal-fired power plants must achieve a 77% cut in nitrogen oxide (NO_x) emissions by 2009 and a 73% cut in sulfur dioxide (SO₂) emissions by 2013. NO_x is the main cause of ozone, one of North Carolina's biggest air quality problems and it contributes to haze and acid rain. SO₂ is the main cause of tiny particle pollution, haze and acid rain. Although the act does not set caps on mercury, it is estimated that the controls needed to meet the NO_x and SO₂ limits will reduce mercury significantly, perhaps as much as 60–90%. Reducing emissions of these pollutants will help control North Carolina's biggest air pollution problems, thereby safe-guarding public health, improving visibility and protecting the environment. An important feature of the Clean Smokestacks Act is that North Carolina's two largest utility companies, Duke Power Co. and Progress Energy Corp. (formerly known as Carolina Power & Light) must achieve these emissions cuts through actual reductions at their 14 power plants in the state – not by buying or trading emissions credits from utilities in other states, as allowed under federal regulations. The utilities also cannot sell credits for their emissions cuts, ensuring that utilities in neighboring states do not negate the gains achieved in North Carolina by purchasing the rights to increase or to avoid controlling their own emissions. The legislation had its genesis in a series of public hearings the state held in 2000 regarding rules for complying with the US Environmental Protection Agency's call for revised State Implementation Plans for controlling NO_x. The hearings attracted large crowds, particularly in the mountains of western North Carolina and helped convince state Representative

Martin Nesbitt and state Senator Stephen Metcalf to co-sponsor a multi-pollutant bill that went beyond the requirements of the EPA's SIP Call.

In the Climate Stewardship Act of 2005, the term 'carbon dioxide equivalents' means, for each greenhouse gas, the amount of each such greenhouse gas that makes the same contribution to global warming as one metric ton of carbon dioxide, as determined by the Administrator. The term 'greenhouse gas' means:

- 1 carbon dioxide
- 2 methane
- 3 nitrous oxide
- 4 hydrofluorocarbons
- 5 perfluorocarbons
- 6 sulfur hexafluoride.

The Assistant Secretary of Technology Policy at the Department of Commerce shall conduct a study of technology transfer barriers, best practices and outcomes of technology transfer activities at Federal laboratories related to the licensing and commercialization of energy efficient technologies and other technologies that, compared to similar technology in commercial use, result in reduced emissions of greenhouse gases or increased sequestration of greenhouse gases. The study shall be submitted to the Senate Committee on Commerce, Science and Transportation and the House of Representatives Committee on Science within 6 months after the date of enactment of this Act. The Assistant Secretary shall work with the existing interagency working group to address identified barriers. Within 6 months after the date of enactment of this Act, the Secretary shall execute a contract with the National Academy of Science for a report to the Senate Committee on Commerce, Science and Transportation and the House of Representatives Committee on Science on the effects that the entry into force of the Kyoto Protocol without USA participation will have on:

- 1 US industry and its ability to compete globally
- 2 international cooperation on scientific research and development
- 3 US participation in international environmental climate change mitigation efforts and technology deployment.

As soon as practicable after the date of enactment of this Act, the Administrator, in coordination with the Secretary, the Secretary of Energy, the Secretary of Agriculture and private sector and non-governmental organizations, shall establish, operate and maintain a database, to be known as the 'National Greenhouse Gas Database', to collect, verify and analyze information on greenhouse gas emissions by entities. The database shall consist of:

- 1 an inventory of greenhouse gas emissions
- 2 a registry of greenhouse gas emission reductions and increases in greenhouse gas sequestrations.

The Secretary, through the National Oceanic and Atmospheric Administration, shall carry out a program of scientific research on potential abrupt climate change designed:

- 1 to develop a global array of terrestrial and oceanographic indicators of paleoclimate in order sufficiently to identify and describe past instances of abrupt climate change
- 2 to improve understanding of thresholds and non-linearities in geophysical systems related to the mechanisms of abrupt climate change
- 3 to incorporate these mechanisms into advanced geophysical models of climate change
- 4 to test the output of these models against an improved global array of records of past abrupt climate changes.

Some major points of the US legislation focused on environment are presented in Table 5.1.

Table 5.1 US Acts (main points and comments) related to environment

Year	Title of Act	Main points	Comments
1947	Federal Insecticide, Fungicide and Rodenticide Act (FIFRA)	<ul style="list-style-type: none"> ● It regulates the use and safety of pesticides within the USA ● FIFRA mandates that users take exams and be certified as pesticide applicators 	
1969	National Environmental Policy Act (NEPA)	<ul style="list-style-type: none"> ● NEPA, one of the first modern environmental laws, establishes a broad national framework for efforts to protect the environment ● Requires that federal agencies assess the environmental impact of implementing their major programs and actions early in the planning process ● Establishes the use of Environmental Assessments (EAs) and Environmental Impact Statements (EISes) by federal agencies 	Amendments > Some Sections of NEPA were amended in 1970, 1975 and 1982
1970	Occupational Safety and Health Act (OSHA)	<ul style="list-style-type: none"> ● Seeks to ensure workplace safety through the regulation of worker exposure to toxic chemicals, excessive noise levels, mechanical dangers, heat or cost stress or unsanitary conditions ● OSHA created the Occupational Safety and Healthy Administration (also known as OSHA), part of the Department of Labor and the National Institute for Occupational Safety and Health (NIOSH) 	
1970	Clean Air Act (CAA)	<ul style="list-style-type: none"> ● It was established to protect and enhance the quality of the nation's air resources so as to promote public health and welfare and the productive capacity of its population 	Amendments > The 1966 amendments expanded local air pollution control programs

(Continued)

Table 5.1 (Continued)

Year	Title of Act	Main points	Comments
		<ul style="list-style-type: none"> ● The CAA establishes emission standards for stationary sources, volatile organic compound emissions, hazardous air pollutants and vehicles and other mobile sources ● The CAA also requires the states to develop implementation plans applicable to particular industrial sources 	<ul style="list-style-type: none"> > The 1967 (Air Quality Act) amendments divided parts of the nation into Air Quality Control Regions (AQCRs) as a means of monitoring ambient air > The 1977 amendments set new timetables and goals for achieving the National Ambient Air Quality Standards (NAAQS) > The 1990 amendments dealt primarily with matters which had not been fully addressed previously, such as acid rain, ozone depletion, and tail-pipe emissions > The CWA was reauthorized in 1987
1972	Clean Water Act (CWA)	<ul style="list-style-type: none"> ● The CWA was established to restore and maintain the chemical, physical and biological integrity of the nation's waters ● The CWA sets goals to eliminate discharges of pollutants into navigable water, protect fish and wildlife and prohibit the discharge of toxic pollutants in quantities that could adversely affect the environment ● The CWA also provides for the construction of publicly-owned wastewater treatment facilities 	
1972	Marine Protection, Research and Sanctuaries Act (MPRSA)	<ul style="list-style-type: none"> ● MPRSA establishes a policy to regulate the dumping of all types of materials into ocean waters ● MPRSA also establishes a policy to prevent or strictly limit the dumping into ocean waters of any material that would adversely affect human health, welfare or the marine environment or systems 	<p>Amendment</p> <ul style="list-style-type: none"> > In 2000, MPRSA was amended and some new elements were added
1972	Coastal Zone Management Act (CZMA)	<ul style="list-style-type: none"> ● CZMA promotes the preservation, protection, development and, where possible, the restoration or enhancement of coastal resources ● States develop management plans for their coastal resources 	
1973	Endangered Species Act (ESA)	<ul style="list-style-type: none"> ● Seeks to conserve endangered and threatened plants, animals and their habitats ● Act requires federal agencies to carry out programs for the conservation of listed species and must take actions to ensure that projects they authorize, fund or implement will not endanger these species ● Act also establishes an Endangered Species Committee to grant exemptions from the Act 	
1974	Safe Drinking Water Act (SDWA)	<ul style="list-style-type: none"> ● It seeks to protect sources of the nation's drinking water and to protect public 	

(Continued)

Table 5.1 (Continued)

Year	Title of Act	Main points	Comments
1974	Hazardous Materials Transportation Act (HMTA)	<p>health to the maximum extent possible, using proper water treatment techniques</p> <ul style="list-style-type: none"> ● SDWA establishes national primary drinking water standards based upon maximum contaminant levels and establishes state management programs to enforce the standards ● SDWA also establishes procedures for the development, implementation and assessment of demonstration programs designed to protect critical aquifer protection areas located within areas designated as sole or principal source aquifers ● HMTA establishes a program of regulating the shipment of hazardous materials that may pose a threat to health, safety, property or the environment when transported by air, water, rail or highway 	
1976	Resource Conservation and Recovery Act (RCRA)	<ul style="list-style-type: none"> ● Addresses solid waste issues and provides EPA with the authority to regulate the disposal of hazardous waste ● Encourages the development of solid waste management plans and non-hazardous waste regulatory programs by the states ● Provides for a national research, development and demonstration program for improved solid waste management and resource conservation techniques ● Prohibits open dumping of wastes; regulates underground storage tanks 	<ul style="list-style-type: none"> > RCRA was amended in 1984 to include the Hazardous and Solid Waste Amendments > RCRA was further amended in 1986 to address environmental problems caused by underground storage tanks containing petroleum and other hazardous substances
1976	Toxic Substances Control Act (TSCA)	<ul style="list-style-type: none"> ● It establishes the EPA's toxic substances program ● Under this law manufacturers may be required to conduct tests to evaluate the characteristics of the substance ● The Act establishes a system for the prioritized listing of chemical substances to be tested ● Under TSCA, manufacturers must notify EPA of their intentions to mass-produce a new chemical substance ● TSCA also regulates polychlorinated biphenyls or PCBs 	<ul style="list-style-type: none"> > In 1986, TSCA was amended to incorporate the Asbestos Hazard Emergency Response Act to address matters relating to asbestos products in public schools and other buildings
1977	Surface Mining Control and Reclamation Act (SMCRA)	<ul style="list-style-type: none"> ● SMCRA establishes a national program for surfacing mining operations ● SMCRA provides for the reclamation of abandoned mines and controls the environmental impacts of surface mining 	
1978	Uranium Mill Tailings Radiation Control Act (UMTRCA)	<ul style="list-style-type: none"> ● UMTRCA regulates the remedial actions for uranium mill tailings 	<ul style="list-style-type: none"> > In 1998, UMTRCA was amended

(Continued)

Table 5.1 (Continued)

Year	Title of Act	Main points	Comments
1980	Comprehensive Environmental Response, Compensation and Liability Act (CERCLA)	<ul style="list-style-type: none"> ● CERCLA provides EPA with the authority to respond to releases of hazardous wastes from 'inactive' hazardous waste sites which endanger public health and the environment ● Establishes a federal 'Superfund' to finance response actions, establishes regulations controlling inactive hazardous waste sites, and establishes liability to recover cleanup costs 	
1980	Low Level Radioactive Policy Act (LRWPA)	<ul style="list-style-type: none"> ● The Act made states responsible for disposing of their own low-level radioactive waste and set forth the federal policy that waste disposal is best handled on a regional basis ● It encouraged states to form interstate compacts, or regional associations of states, for the purpose of low-level radioactive waste disposal. States that are not members of any compact are often referred to as unaffiliated states 	
1986	Superfund Amendments and Reauthorization Act (SARA)	<ul style="list-style-type: none"> ● SARA established emergency planning, reporting and notification requirements to protect the public in the event of a release of hazardous substances 	
1989	Soil Conservation and Land Care Act (SCLCA)	<ul style="list-style-type: none"> ● An Act to provide for the conservation and rehabilitation of the land of this State and for other purposes ● This Act is published under the Legislation Revision and Publication Act 2002 and incorporates all amendments in force as at 24 November 2003 	
1990	Oil Pollution Act (OPA)	<ul style="list-style-type: none"> ● Definitions ● OPA provisions establish strict liability for damages caused by oil spills in navigable water ● OPA requires vessel and facility operators to file detailed oil spill response plans and the replacement of single-hull oil tankers and barges with double-hull vessels ● OPA creates a \$1 billion supplemental compensation fund for oil spills 	
1990	Pollution Prevention Act (PPA)	<ul style="list-style-type: none"> ● PPA established the prevention of pollution as a national objective ● It required the EPA to develop and implement a strategy to promote source reduction ● The PPA amended EPCRA through the Toxic Chemical Release Inventory (TRI), which requires facilities to file an annual toxic chemical release form and to provide information on pollution prevention and recycling for each facility and for each toxic chemical 	

(Continued)

Table 5.1 (Continued)

Year	Title of Act	Main points	Comments
1992	Federal Facility Compliance Act (FFCA)	<ul style="list-style-type: none"> ● FFCA amended RCRA to ensure that federal facilities complied with all federal, state and local solid and hazardous waste laws 	
2002	Nuclear Waste Policy Act (NWPA)	<ul style="list-style-type: none"> ● Definitions (high-level radioactive waste etc.) ● Available capacity for interim storage of spent nuclear fuel ● Laying down the transportation of spent nuclear fuel 	
2002	Clean Smokestacks Act	<ul style="list-style-type: none"> ● It requires power companies to reduce their smog- and haze-forming emissions by approximately three-fourths over the next decade ● Power companies must reduce their NO_x emissions year-round 	
2004	Environmental Management Act (EMA)	<ul style="list-style-type: none"> ● The EMA provides enabling provisions for modern environmental management tools – such as area-based planning and administrative monetary penalties ● The act brings provisions from both Waste Management Act and Environment Management Act into one statute ● Entry into force on 8 July 2004 	Repeal > Waste Management Act
2005	Climate Stewardship Act	<ul style="list-style-type: none"> ● It was introduced to provide for a program of scientific research on abrupt climate change ● It was also introduced to accelerate the reduction of greenhouse gas emissions in the USA by establishing a market-driven system of greenhouse gas tradeable allowances ● It aimed to limit greenhouse gas emissions in the USA and reduce dependence upon foreign oil and ensure benefits to consumers from the trading in such allowances. 	

Canadian legislation for environment

In the Canada Water Act of 1970, ‘boundary waters’ means the waters from main shore to main shore of the lakes and rivers and connecting waterways, or the portions thereof, along which the international boundary between the USA and Canada passes, including all bays, arms and inlets thereof, but not including tributary waters which in their natural channels would flow into such lakes, rivers and waterways, or waters

flowing from such lakes, rivers and waterways or the waters of rivers flowing across the boundary; 'waste' means:

- 1 any substance that, if added to any water would degrade or alter or form part of a process of degradation or alteration of the quality of that water to an extent that is detrimental to their use by man or by any animal, fish or plant that is useful to man
- 2 any water that contains a substance in such a quantity or concentration or that has been so treated, processed or changed, by heat or other means, from a natural state that it would, if added to any other water, degrade or alter or form part of a process of degradation or alteration of the quality of that water to the extent described in this paragraph

and 'water quality management' means any aspect of water resource management that relates to restoring, maintaining or improving the quality of water. For the purpose of facilitating the formulation of policies and programs with respect to the water resources of Canada and to ensure the optimum use of those resources for the benefit of all Canadians, having regard to the distinctive geography of Canada and the character of water as a natural resource, the Minister may, with the approval of the Governor in Council, enter into an arrangement with one or more provincial governments to establish, on a national, provincial, regional, lake or river-basin basis, inter-governmental committees or other bodies:

- 1 to maintain continuing consultation on water resource matters and to advise on priorities for research, planning, conservation, development and utilization relating thereto
- 2 to advise on the formulation of water policies and programs
- 3 to facilitate the coordination and implementation of water policies and programs.

Subject to this Act, the Minister may, with the approval of the Governor in Council, with respect to any waters where there is a significant national interest in the water resource management thereof, enter into agreements with one or more provincial governments having an interest in the water resource management of those waters, providing for programs to:

- 1 establish and maintain an inventory of those waters
- 2 collect, process and provide data on the quality, quantity, distribution and use of those waters
- 3 conduct research in connection with any aspect of those waters or provide for the conduct of any such research by or in cooperation with any government, institution or person
- 4 formulate comprehensive water resource management plans, including detailed estimates of the cost of implementation of those plans and of revenues and other benefits likely to be realized from the implementation thereof, based on an examination of the full range of reasonable alternatives and taking into account views expressed at public hearings and otherwise by persons likely to be affected by implementation of the plans

- 5 design projects for the efficient conservation, development and utilization of those waters
- 6 implement any plans or projects referred to in this paragraph and establishing or naming joint commissions, boards or other bodies empowered to direct, supervise and coordinate those programs.

The Canada Wildlife Act of 1973–74 made clear that the Minister may, with the approval of the Governor in Council, enter into an agreement with the governor of any province to provide for:

- 1 the undertaking of wildlife research, conservation and interpretation programs and measures, the administration of lands for those purposes or the construction, maintenance and operation of facilities and works related thereto
- 2 the payment of contributions in respect of the costs of those programs and measures.

Any agreement entered into pursuant to this section shall:

- 1 specify the portions, if any, of the cost of any programs or measure to which the agreement relates that are payable by the Government of Canada and the government of the province or the amount of any contribution in respect of the cost of any program or measure that is payable by the Government of Canada and the time or times at which any amounts under the agreement will be paid
- 2 specify the authority that will be responsible for the undertaking, operation and maintenance of any programs or measure to which the agreement relates or any part thereof
- 3 specify the proportions of the revenues from any program or measure to which the agreement relates and the charges, if any, to be charged to persons to whom any of the benefits of the program or measure are made available. The Government in Council may authorize the Minister to purchase, acquire or lease any lands or interest therein for the purpose of research, conservation and interpretation in respect of migratory birds or, with the agreement of the government of the province having an interest therein, other wildlife.

According to the Canada Shipping Act of 1978, ‘black smoke’ was defined smoke that appears black or approximately black and ‘smoke’ means any solid, liquid, gas or combination thereof produced by the combustion of fuel and includes soot, ash and grit. The smoke chart to be used in determining the density of black smoke for the purpose of these Regulations is the Department of Transport Smoke Chart set out in the schedule or a comparable chart upon which fine black dots or lines evenly spaced on a white ground are so arranged as to indicate:

- 1 density No.1, by having approximately 20% of the space black
- 2 density No.2, by having approximately 40% of the space black
- 3 density No.3, by having approximately 60% of the space black
- 4 density No.4, by having approximately 80% of the space black

5 density No.5, by having approximately 100% of the space black.

No person shall operate or permit the operation of any fuel-burning installation on a ship so that smoke is emitted in greater density than the maximum density authorized by this section. Any fuel-burning installation utilizing hand-fired boilers may:

- 1 while in the Detroit River, emit smoke of a density not greater than density No.3 for an aggregate of not more than 9 minutes in any 30-minute period
- 2 while elsewhere than in the Detroit River, emit smoke
 - i of a density not greater than density No.3 for an aggregate of not more than 9 minutes in any 30-minute period
 - ii of a density not greater than density No.4 for an aggregate of not more than 3 minutes in any 30-minute period.

Where smoke is emitted from a ship contrary to these Regulations, the owner and master of the ship, as well as the person directly responsible for the emission of the smoke, is guilty of an offense and liable on summary conviction to a fine not exceeding \$500 or to imprisonment for a term not exceeding six months or to both.

For the purpose of Coastal Fisheries Protection Act of 1982, 'Canadian fisheries waters' means all waters in the fishing zones of Canada, all waters in the territorial sea of Canada and all internal waters of Canada; 'Canadian fishing vessel' means a fishing vessel:

- 1 that is registered or licensed under the Canada Shipping Act
- 2 that is not registered or licensed under the Canada Shipping Act or under the laws of another state but is owned by one or more persons each of whom is
 - i a Canadian citizen
 - ii in the case of a vessel that is not required to be registered or licensed under that Act, a person resident and domiciled in Canada
 - iii a corporation incorporated under the laws of Canada or a province, having its principal place of business in Canada.

No person, being aboard a foreign fishing vessel or being a member of the crew of or attached to or employed on a foreign fishing vessel, shall in Canada or in Canadian fisheries waters:

- 1 fish or prepare to fish
- 2 unload, land or tranship any fish, outfit or supplies
- 3 ship or discharge any crew member or other person
- 4 purchase or obtain bait or any supplies or outfits
- 5 take or prepare to take marine plants, unless authorized by this Act or the regulations, any other law of Canada or a treaty.

No person, being aboard a foreign fishing vessel or being a member of the crew of or attached to or employed on a foreign fishing vessel, shall fish or prepare to fish for a

sedentary species of fish in any portion of the continental shelf of Canada that is beyond the limits of Canadian fisheries waters, unless authorized by this Act or the regulations or any other law of Canada. The Governor in Council may make regulations for carrying out the purposes and provisions of this Act including, but not limited to, regulations:

- 1 for authorizing, by means of licenses, permits or otherwise
 - i foreign fishing vessels to enter Canadian fisheries waters for any purpose specified in the regulations
 - ii persons to do all or any of the things described in this section
- 2 respecting the issuance, suspension and cancellation of any licenses or permits provided for under this paragraph and prescribing their forms, the fees payable therefore and their terms and conditions, which are in addition to such terms and conditions
- 3 for appointing or authorizing persons to enforce the provisions of this Act and the regulations
- 4 for securing and keeping any fishing vessels or things seized pursuant to this Act
- 5 for the implementation of the Agreement, including regulations
 - i designating any area of the sea regulated by the regional fisheries management organization or arrangement
 - ii setting out the circumstances in which a person engaged or employed in the administration or enforcement of this Act may exercise, in a manner consistent with the Agreement and the measures incorporated by reference and the regulations made under this paragraph, the powers conferred by or under this Act and setting out any procedures to be followed in doing so
 - iii empowering the Minister to authorize a participating state to take enforcement action in respect of a Canadian fishing vessel
 - iv respecting the manner of service and the giving and sending of summonses, notices, statements and other documents
- 6 for the implementation of the provisions of any other international fisheries treaty or arrangement to which Canada is party, including any conservation, management or enforcement measures taken under the treaty or arrangement.

The Radiation Emitting Devices Act of 1985 claims that where a person who is the manufacturer or importer of a radiation emitting device becomes aware, after the device has left the person's premises, of the fact that the device:

- 1 does not comply with the standards, if any, prescribed under this paragraph and applicable thereto
- 2 creates a risk to any person of genetic or personal injury, impairment of health or death from radiation by reason of the fact that it
 - i does not perform according to the performance characteristics claimed for it
 - ii does not accomplish its claimed purpose
 - iii emits radiation that is not necessary in order for it to accomplish its claimed purpose, the person shall forthwith notify the Minister.

An inspector may at any reasonable time enter, subject to this subsection, the premises of any manufacturer, distributor or importer of a radiation emitting device in which he believes on reasonable grounds there is a radiation emitting device, or any place in which he believes on reasonable grounds there is a radiation emitting device that is owned by a manufacturer, distributor or importer, and may:

- 1 examine any radiation emitting device found therein and take it away for further examination
- 2 open and examine any package that the inspector believes on reasonable grounds contains a radiation emitting device and take it away for further examination
- 3 examine any books, reports, test data, records, shipping bills and bills of lading or other documents or papers found in any premises or place referred to in this subsection that the inspector believes on reasonable grounds contain any information relevant to the enforcement of this Act and make copies thereof or extracts therefrom.

A radiation emitting device seized pursuant to this subsection shall not be detained after:

- 1 the provisions of any regulations made under this section that are applicable to that device have, in the opinion of the inspector, been complied with
- 2 the expiration of ninety days from the day of seizure or such longer period as may be prescribed with respect to any device, unless before that time proceedings have been instituted in respect of the contravention, in which case the device may be detained until the proceedings are finally concluded.

An interim order has effect from the time that it is made but ceases to have effect on the earliest of

- 1 14 days after it is made, unless it is approved by the Governor in Council
- 2 the day on which it is repealed
- 3 the day on which a regulation made under this Act, that has the same effect as the interim order, comes into force
- 4 one year after the interim order is made or any shorter period that may be specified in the interim order.

In any prosecution for an offense under this Act, it is sufficient proof of the offense to establish that it was committed by an employee or agent of the accused whether or not the employee or agent is identified or has been prosecuted for the offense, unless the accused establishes that the offense was committed without the knowledge or consent of, and that all due diligence to prevent its commission was exercised by, the accused.

For the purpose of the Canada Hazardous Products Act of 1985, the term 'controlled product' means any the product, material or substance specified by the regulations and the term 'hazardous product' means any prohibited product, restricted product or controlled product. This Part does not apply in respect of the sale or importation of any:

- 1 explosive within the meaning of the Explosives Act
- 2 cosmetic, device, drug or food within the meaning of the Food and Drugs Act

- 3 control product within the meaning of the Pest Control Products Act
- 4 substance, within the meaning of the Nuclear Safety and Control Act, that is radioactive
- 5 hazardous waste
- 6 product, material or substance packaged as a consumer product
- 7 wood or product made of wood
- 8 tobacco or a tobacco product as defined in section of the Tobacco Act
- 9 manufactured article.

For the purposes of this Part, a label is applied to a controlled product or container in which a controlled product is packaged if the label is attached to, imprinted on, stencilled on or embossed on the controlled product or container or, in the case of a bulk shipment of a controlled product, is included with or caused to accompany the bulk shipment in the manner prescribed. An inspector may at any reasonable time enter any place where the inspector believes on reasonable grounds any hazardous product is manufactured, prepared, preserved, processed, packaged, sold or stored for sale, processing or packaging and:

- 1 examine any product, material or substance that the inspector believes on reasonable grounds is a hazardous product and take samples thereof and examine any other thing that the inspector believes on reasonable grounds is used or is capable of being used for the manufacture, preparation, preservation, processing, packaging, sale or storage of a hazardous product
- 2 open and examine any receptacle or package that the inspector believes on reasonable grounds contains any hazardous product
- 3 examine any books, records or other documents that the inspector believes on reasonable grounds contain any information relevant to the enforcement of this Act and make copies thereof or of any portion thereof
- 4 where the inspector believes on reasonable grounds that any computer system on the premises contains data relevant to the enforcement of this Act or that such data are available to the computer system, use the computer system or cause it to be used to search any data contained in or available to the computer system, reproduce any record or cause it to be reproduced from the data in the form of a printout or other intelligible output and seize the printout or other output for examination or copying
- 5 seize any product, material or substance, or any labeling, advertising material or other thing, by means of or in relation to which the inspector believes on reasonable grounds any provision of this Act or of any regulation made under this Act has been contravened or has not been complied with

First, some of the definitions of Canadian Environmental Assessment Act of 1992 are 'environment' which means the components of the Earth and includes:

- 1 land, water and air, including all layers of the atmosphere
- 2 all organic and inorganic matter and living organisms
- 3 the interacting natural systems that include components referred to in this paragraph,

‘environmental effect’ which means, in respect of a project:

- 1 any change that the project may cause in the environment, including any change it may cause to a listed wildlife species, its critical habitat or the residences of individuals of that species, as those terms are defined in subsection of the Species at Risk Act
- 2 any effect of any change referred to in this paragraph on
 - i health and socio-economic conditions
 - ii physical and cultural heritage
 - iii the current use of lands and resources for traditional purposes by aboriginal persons
 - iv any structure, site or thing that is of historical, archeological, paleontological or architectural significance
- 3 any change to the project that may be caused by the environment, whether any such change or effect occurs within or outside Canada

and ‘sustainable development’ which means development that meets the needs of the present, without compromising the ability of future generations to meet their own needs.

The purposes of this Act are:

- 1 to ensure that projects are considered in a careful and precautionary manner before federal authorities take action in connection with them, in order to ensure that such projects do not cause significant adverse environmental effects
- 2 to encourage responsible authorities to take actions that promote sustainable development and thereby achieve or maintain a healthy environment and a healthy economy to ensure that responsible authorities carry out their responsibilities in a coordinated manner with a view to eliminating unnecessary duplication in the environmental assessment process, to promote cooperation and coordinated action between federal and provincial governments with respect to environmental assessment processes for projects and to promote communication and cooperation between responsible authorities and Aboriginal peoples with respect to environmental assessment
- 3 to ensure that projects that are to be carried out in Canada or on federal lands do not cause significant adverse environmental effects outside the jurisdictions in which the projects are carried out
- 4 to ensure that there be opportunities for timely and meaningful public participation throughout the environmental assessment process.

The environmental assessment of a project under this section shall be conducted where:

- 1 the project is to be carried out on federal lands and the prescribed authority is the proponent of the project and does any act or thing that commits it to carrying out the project in whole or in part
- 2 the project is to be carried out on federal lands and the prescribed authority makes or authorizes payments or provides a guarantee for a loan or any other form of

financial assistance to the proponent for the purpose of enabling the project to be carried out in whole or in part

- 3 the prescribed authority sells, leases or otherwise disposes of federal lands or any interests in those lands, for the purpose of enabling the project to be carried out in whole or in part
- 4 the prescribed authority, under a provision prescribed under this paragraph, issues a permit or license, grants an approval or takes any other action for the purpose of enabling the project to be carried out in whole or in part
- 5 in circumstances prescribed by regulations made under this paragraph, a project is to be carried out in whole or in part on federal lands over which the prescribed authority has administration or management or any right or interest specified in those regulations.

The purpose of the Nuclear Safety and Control Act of 1997 is to provide for:

- 1 the limitation, to a reasonable level and in a manner that is consistent with Canada's international obligations, of the risks to national security, the health and safety of persons and the environment that are associated with the development, production and use of nuclear energy and the production, possession and use of nuclear substances, prescribed equipment and prescribed information
- 2 the implementation in Canada of measures to which Canada has agreed respecting international control of the development, production and use of nuclear energy, including the non-proliferation of nuclear weapons and nuclear explosive devices.

'Nuclear energy' means any form of energy released in the course of nuclear fission or nuclear fusion or of any other nuclear transmutation, 'nuclear substance' means:

- 1 deuterium, thorium, uranium or an element with an atomic number greater than 92
- 2 a derivative or compound of deuterium, thorium, uranium or of an element with an atomic number greater than 92
- 3 a radioactive nuclide
- 4 a substance that is prescribed as being capable of releasing nuclear energy or as being required for the production or use of nuclear energy
- 5 a radioactive by-product of the development, production or use of nuclear energy
- 6 a radioactive substance or radioactive thing that was used for the development or production, or in connection with the use, of nuclear energy.

'Radiation' means the emission by a nuclear substance, the production using a nuclear substance, or the production at a nuclear facility, of an atomic or subatomic particle or electromagnetic wave with sufficient energy for ionization.

According to the Canadian Environmental Protection Act of 1999, 'air pollution' means a condition of the air, arising wholly or partly from the presence in the air of any substance, that directly or indirectly:

- 1 endangers the health, safety or welfare of humans
- 2 interferes with the normal enjoyment of life or property

- 3 endangers the health of animal life
- 4 causes damage to plant life or to property
- 5 degrades or alters, or forms part of a process of degradation or alteration of, an ecosystem to an extent that is detrimental to its use by humans, animals or plants.

‘Biotechnology’ means the application of science and engineering in the direct or indirect use of living organisms or parts or products of living organisms in their natural or modified forms, ‘environment’ means the components of the Earth and includes:

- 1 air, land and water
- 2 all layers of the atmosphere
- 3 all organic and inorganic matter and living organisms
- 4 the interacting natural systems that include components referred to in this paragraph.

‘Substance’ means any distinguishable kind of organic or inorganic matter, whether animate or inanimate, and includes:

- 1 any matter that is capable of being dispersed in the environment or of being transformed in the environment into matter that is capable of being so dispersed or that is capable of causing such transformations in the environment
- 2 any element or free radical
- 3 any combination of elements of a particular molecular identity that occurs in nature or as a result of a chemical reaction
- 4 complex combinations of different molecules that originate in nature or are the result of chemical reactions but that could not practicably be formed by simply combining individual constituents and includes
- 5 any mixture that is a combination of substances and does not itself produce a substance that is different from the substances that were combined
- 6 any manufactured item that is formed into a specific physical shape or design during manufacture and has, for its final use, a function or functions dependent in whole or in part on its shape or design
- 7 any animate matter that is, or any complex mixtures of different molecules that are, contained in effluents, emissions or wastes that result from any work, undertaking or activity.

‘Sustainable development’ means development that meets the needs of the present without compromising the ability of future generations to meet their own needs, ‘marine pollution’ means the introduction by humans, directly or indirectly, of substances or energy into the sea that results, or is likely to result, in:

- 1 hazards to human health
- 2 harm to living resources or marine ecosystems
- 3 damage to amenities
- 4 interference with other legitimate uses of the sea.

An environmental protection action may not be brought if the alleged conduct:

- 1 was taken
 - i to correct or mitigate harm or the risk of harm to the environment or to human, animal or plant life or health
 - ii to protect national security, support humanitarian relief efforts, participate in multilateral military or peace-keeping activities under the auspices of international organizations or defend a member state of the North Atlantic Treaty Organization
- 2 was reasonable and consistent with public safety.

Any person who has suffered loss or damage as a result of conduct that contravenes any provision of this Act or the regulations may, in any court of competent jurisdiction, bring an action to recover from the person who engaged in the conduct.

- 1 an amount equal to the loss or damage proved to have been suffered by the person
- 2 an amount to compensate for the costs that the person incurs in connection with the matter and proceedings under this section.

The Minister shall:

- 1 establish, operate and maintain a system for monitoring environmental quality
- 2 conduct research and studies relating to pollution prevention, the nature, transportation, dispersion, effects, control and abatement of pollution and the effects of pollution on environmental quality and provide advisory and technical services and information related to that research and those studies
- 3 conduct research and studies relating to
 - i environmental contamination arising from disturbances of ecosystems by human activity
 - ii changes in the normal geochemical cycling of toxic substances that are naturally present in the environment
 - iii detection and damage to ecosystem
- 4 collect, process, correlate, interpret, create an inventory of and publish on a periodic basis data on environmental quality in Canada from monitoring systems, research, studies and any other sources
- 5 formulate plans for pollution prevention and the control and abatement of pollution, including plans respecting the prevention of, preparedness for and response to an environmental emergency and for restoring any part of the environment damaged by or during an emergency and establish, operate and publicize demonstration projects and make them available for demonstration
- 6 publish, arrange for the publication of or distribute through an information clearing-house
 - i information respecting pollution prevention
 - ii pertinent information in respect of all aspects of environmental quality
 - iii a periodic report on the state of the Canadian environment.

A Canadian permit shall contain any conditions that the Minister considers necessary for the protection of marine life, any legitimate uses of the sea or human life, including conditions relating to the following:

- 1 the nature and quantity of the substance for loading, disposal or incineration
- 2 the method and frequency of the disposal or incineration authorized including, if necessary, the date or dates on which disposal or incineration is authorized
- 3 manner of loading and stowing the substance authorized for disposal or incineration
- 4 the site at which disposal or incineration may take place
- 5 the route to be followed by the ship or aircraft transporting the substance to the disposal or incineration site
- 6 any special precautions to be taken respecting the loading, transporting, disposal or incineration of the substance
- 7 the monitoring of the disposal, the incineration and the disposal site to determine the effects of the disposal on the environment and human life.

This Act includes regulation for:

- 1 toxic substances
- 2 products of biotechnology
- 3 controlling pollution and managing wastes
- 4 protection of the marine environment
- 5 fuels
- 6 vehicles, engine and equipment emissions
- 7 international air pollution
- 8 international water pollution.

For the Canada Foundation for Sustainable Development Technology Act of 2001, 'sustainable development' means development that meets the needs of the present without compromising the ability of future generations to meet their own needs. The corporation is continued as a corporation without share capital, to be called the Canada Foundation for Sustainable Development Technology, consisting of the Foundation's members and directors. The board of directors of the corporation ceases to exist and there shall be a board of directors of the Foundation that shall supervise the management of the business and affairs of the Foundation and, subject to the by-laws of the Foundation, exercise all its powers. A director ceases to be a director when the director

- 1 dies
- 2 resigns
- 3 is appointed to the Senate
- 4 is elected to the House of Commons or to the legislature of a province
- 5 becomes an employee or agent of Her Majesty in right of Canada or in right of a province

- 6 ceases to be ordinarily resident in Canada
- 7 becomes disqualified under the Canada Business Corporations Act
- 8 is removed from office under this subsection.

A person is not eligible to be appointed as a member if the person:

- 1 is a member of the Senate, the House of Commons or the legislature of a province
- 2 is an employee or agent of Her Majesty in right of Canada or in right of a province
- 3 is a director
- 4 does not ordinarily reside in Canada
- 5 is disqualified under the Canada Business Corporations Act.

The appointment of members shall be made having regard to the following considerations:

- 1 the need to ensure, as far as possible, that at all times the membership will be representative of
 - i persons engaged in the development and demonstration of technologies to promote sustainable development, including technologies to address issues related to climate change and the quality of air, water and soil
 - ii the business community
 - iii not-for-profit organizations
- 2 the importance of having membership that is representative of various regions of Canada and includes men and women who are able to contribute to the achievement of the objects and purposes of the Foundation
- 3 the need for a membership that has sufficient knowledge of technologies.

The Nuclear Fuel Waste Act of 2002 makes clear that ‘management’, in relation to nuclear fuel waste, means long-term management by means of storage or disposal, including handling, treatment, conditioning or transport for the purpose of storage or disposal, ‘nuclear energy corporation’ means

- 1 Ontario Power Generation Inc., Hydro-Québec, New Brunswick Power Corporation and any other body that owns nuclear fuel waste resulting from the production of electricity by means of a commercial nuclear reactor
- 2 any successor or assignee of a corporation mentioned in this paragraph
- 3 any assignee of Atomic Energy of Canada Limited, being the company incorporated or acquired pursuant to the Atomic Energy Control Act.

‘Nuclear fuel waste’ means irradiated fuel bundles removed from a commercial or research nuclear fission reactor. The members of the Advisory Council shall be appointed by the governing body of the waste management organization. The governing body shall make all reasonable efforts to ensure that the Advisory Council’s membership:

- 1 reflects a broad range of scientific and technical disciplines related to the management of nuclear fuel waste

- 2 reflects expertise, in matters of nuclear energy
 - i in public affairs
 - ii as needed, in other social sciences; reflects expertise in traditional aboriginal knowledge
- 3 includes representatives nominated by local and regional governments and aboriginal organizations that are affected because their economic region is specified for the approach that the Governor in Council selects under section.

Each nuclear energy corporation and Atomic Energy of Canada Limited shall maintain in Canada, either individually or jointly with one or more of the other nuclear energy corporations or Atomic Energy of Canada Limited, one trust fund with a financial institution incorporated or formed by or under an Act of Parliament or of the legislature of a province, except, in the case of a nuclear energy corporation, a financial institution in relation to which the nuclear energy corporation beneficially owns, directly or indirectly, more than 10% of the outstanding shares of any given class of shares. Each annual report after the date of the decision of the Governor in Council under this section must include:

- 1 the form and amount of any financial guarantees that have been provided during that fiscal year by the nuclear energy corporations and Atomic Energy of Canada Limited under the Nuclear Safety and Control Act and relate to implementing the approach that the Governor in Council selects under this section
- 2 the updated estimated total cost of the management of nuclear fuel waste
- 3 the budget forecast for the next fiscal year
- 4 the proposed formula for the next fiscal year to calculate the amount required to finance the management of nuclear fuel waste and an explanation of the assumptions behind each term of the formula
- 5 the amount of the deposit required to be paid during the next fiscal year by each of the nuclear energy corporations and Atomic Energy of Canada Limited and the rationale by which those respective amounts were arrived at.

The definitions in the Pest Control Products Act of 2002 are: ‘active ingredient’ means a component of a pest control product to which the intended effects of the product are attributed and includes a synergist but does not include a solvent, diluent, emulsifier or other component that is not primarily responsible for those effects; ‘biological diversity’ means the variability among living organisms from all sources, including, without limiting the generality of the foregoing, terrestrial and marine and other aquatic ecosystems and the ecological complexes of which they form a part and includes the diversity within and between species and of ecosystems; ‘environmental risk’, in respect of a pest control product, means the possibility of harm to the environment, including its biological diversity, resulting from exposure to or use of the product, taking into account its conditions or proposed conditions of registration and ‘pest control product’ means

- 1 a product, an organism or a substance, including a product, an organism or a substance derived through biotechnology, that consists of its active ingredient, formulants and

contaminants and that is manufactured, represented, distributed or used as a means for directly or indirectly controlling, destroying, attracting or repelling a pest or for mitigating or preventing its injurious, noxious or troublesome effects

- 2 an active ingredient that is used to manufacture anything described in this paragraph
- 3 any other thing that is prescribed to be a pest control product.

No person shall handle, store, transport, use or dispose of a pest control product in a way that is inconsistent with:

- 1 the regulations
- 2 if the product is registered, the directions on the label recorded in the Register, subject to the regulations.

When making a decision regarding the registration of a pest control product, the Minister shall, if necessary, specify any maximum residue limits for the product or for its components or derivatives that the Minister considers appropriate in the circumstances. A special review of a pest control product is initiated by the Minister delivering a notice in writing to the registrant explaining the reasons for initiating the special review and, if considered necessary by the Minister, requiring the registrant to provide information in the form and within the period specified in the notice. Every person who fails to comply with the conditions of an authorization issued under this section is guilty of an offense and liable:

- 1 on summary conviction, to a fine of not more than \$200 000 or to imprisonment for a term of not more than six months, or to both
- 2 on conviction on indictment, to a fine of not more than \$500 000 or to imprisonment for a term of not more than three years, or to both.

Every person is guilty of an offense if, while contravening this Act or the regulations, they willfully or recklessly cause:

- 1 a risk of imminent death or serious bodily harm to another person
- 2 a risk of substantial harm to the environment
- 3 harm to the environment.

According to the Environmental Management Act of 2003, a person who produces, stores, transports, handles, treats, recycles, deals with, processes or owns a hazardous waste must keep the hazardous waste confined in accordance with the regulations. A person must not store more than a prescribed amount of a hazardous waste except in accordance with any of the following that apply:

- 1 the regulations in relation to storing hazardous waste
- 2 an order that requires the person to store that kind of hazardous waste
- 3 an approved waste management plan that provides for storage of hazardous waste.

A person who produces or stores a hazardous waste:

- 1 must not cause or allow more than a prescribed quantity of the hazardous waste to be transported from the property where he or she produces or stores the hazardous waste unless the person first
 - i completes, in the form and manner prescribed, the part of a manifest that applies to him or her
 - ii files the manifest in the manner prescribed
- 2 must ensure that the person transporting more than the prescribed quantity of the hazardous waste from the place where it is produced or stored has a license for that purpose, if a license is required by the regulations
- 3 must not cause or allow more than the prescribed quantity of the hazardous waste to be transported to a place unless
 - i an order, waste management plan or regulation authorizes or requires it to be stored at that place
 - ii a permit, approval, order, waste management plan or regulation authorizes or requires it to be introduced into the environment or treated at that place
 - iii storage of the hazardous waste at that place is otherwise not prohibited under hazardous waste storage and disposal.

A director may issue a permit authorizing the introduction of waste into the environment subject to requirements for the protection of the environment that the director considers advisable and, without limiting that power, may do one or more of the following in the permit:

- 1 require the permittee to repair, alter, remove, improve or add to works or to construct new works and to submit plans and specifications for works specified in the permit
- 2 require the permittee to give security in the amount and form and subject to conditions the director specifies
- 3 require the permittee to monitor, in the manner specified by the director, the waste, the method of handling, treating, transporting, discharging and storing the waste and the places and things that the director considers will be affected by the discharge of the waste or the handling, treatment, transportation or storage of the waste
- 4 require the permittee to conduct studies and to report information specified by the director in the manner specified by the director
- 5 specify procedures for monitoring and analysis, and procedures or requirements respecting the handling, treatment, transportation, discharge or storage of waste that the permittee must fulfill
- 6 require the permittee to recycle certain wastes and to recover certain re-usable resources, including energy potential from wastes.

A director, on receipt of an application or on his or her own initiative, may amend a permit authorizing an introduction of waste described in this subsection, if:

- 1 in the opinion of the director, the amendment is necessary for the protection of the environment

- 2 the amendment is for one or more of the following purposes:
 - i a change of ownership or name
 - ii a change of address
 - iii a decrease in the authorized quantity of the discharge, emission or stored material
 - iv an increase of not more than 10% in the authorized quantity of the discharge, emission or stored material
 - v a change in the authorized quality of the discharge, emission or stored material such that, in the opinion of the director, the change has resulted in or will result in an equal or lesser impact on the environment
 - vi a change in a monitoring program
 - vii a change to the works, method of treatment or any other condition of a permit or an approval such that, in the opinion of the director, the change has resulted in or will result in an equal or lesser impact on the environment.

According to the Environmental Management Act (EMA) of 2004, the term 'waste' includes:

- 1 air contaminants
- 2 litter
- 3 effluent
- 4 refuse
- 5 biomedical waste
- 6 hazardous waste
- 7 any other substance prescribed by the Lieutenant Governor in Council.

'Waste management facility' means a facility for the treatment, recycling, storage, disposal or destruction of a waste, 'waste management plan' means a plan that contains provisions or requirements for the management of recyclable material or other waste or a class of waste within all or a part of one or more municipalities. The duties, powers and functions of the minister extend to any matter relating to the management, protection and enhancement of the environment including, but not limited to, the following matters:

- 1 planning, research and investigation in relation to the environment
- 2 development of policies for the management, protection and use of the environment
- 3 planning, design, construction, operation and maintenance of works and undertakings for the management, protection or enhancement of the environment
- 4 providing information to the public about the quality and use of the environment
- 5 preparing and publishing policies, strategies, objectives, guidelines and standards for the protection and management of the environment
- 6 preparing and publishing environmental management plans for specific areas of British Columbia which may include, but need not be limited to, measures with respect to the following flood control, flood hazard management and development

of land that is subject to flooding, drainage, soil conservation, water resource management, fisheries and aquatic life management, wildlife management, waste management, air management.

A person must not store more than a prescribed amount of a hazardous waste except in accordance with any of the following that apply:

- 1 the regulations in relation to storing hazardous waste
- 2 an order that requires the person to store that kind of hazardous waste
- 3 an approved waste management plan that provides for storage of hazardous waste.

Despite anything in its letters patent or supplementary letters patent, the Greater Vancouver Regional District may provide the service of air-pollution control and air quality management and, for that purpose, the board of the regional district may, by law, prohibit, regulate and otherwise control and prevent the discharge of air contaminants. A director may order that a responsible person, at the person's own expense, provide, in accordance with any regulations, for public consultation on a proposed remediation or a public review of remediation activities. For the purpose of deciding whether to make an order under subsection (1), the director may take into account any factors the director considers relevant, including without limitation, the following:

- 1 the size and location of the contaminated site
- 2 the nature of contamination at the contaminated site
- 3 the potential for human exposure to contamination
- 4 the impact on the environment of the contamination
- 5 migration of contamination off the site
- 6 the remediation methods proposed to be used and the potential for long-term health, environmental or financial impacts
- 7 opportunities for public involvement provided by any municipal development approval process
- 8 whether consultation with the public would improve the quality of information in a site investigation
- 9 whether consultation with the public would enable a well informed choice on the preferred remediation alternative
- 10 the extent to which public consultation has already taken place.

Following the Navigable Waters Protection Act of 2004, the Minister may make an interim order that contains any provision that may be contained in a regulation made under this Part if the Minister believes that immediate action is required to deal with a significant risk, direct or indirect, to safety or security. An interim order has effect from the time that it is made but ceases to have effect on the earliest of:

- 1 14 days after it is made, unless it is approved by the Governor in Council
- 2 the day on which it is repealed

- 3 the day on which a regulation made under this Part, that has the same effect as the interim order, comes into force
- 4 one year after the interim order is made or any shorter period that may be specified in the interim order.

If, in the opinion of the Minister:

- 1 navigation of any navigable water over which Parliament has jurisdiction is obstructed, impeded or rendered more difficult or dangerous by reason of the wreck, sinking, partial sinking, lying ashore or grounding of any vessel or part thereof or other thing
- 2 by reason of the situation of any wreck, vessel or part thereof or other thing so lying, sunk, partially sunk, ashore or grounded, the navigation of any such navigable water is likely to be obstructed, impeded or rendered more difficult or dangerous
- 3 any vessel or part thereof, wreck or other thing cast ashore, stranded or left on any property belonging to Her Majesty in right of Canada is an obstacle or obstruction to such use of that property as may be required for the public purposes of Canada

the Minister may cause the wreck, vessel or part thereof or other thing to be removed or destroyed, in such manner and by such means as the Minister thinks fit, if the obstruction, obstacle, impediment, difficulty or danger continues for more than twenty-four hours. The Governor in Council may make regulations to govern:

- 1 the laying, stretching or maintaining of any ferry cable
- 2 the maintenance of lights and any other precautions for the safety of navigation in connection with such a ferry cable
- 3 the opening and closing of any swing or draw bridge over any navigable water
- 4 the maintenance of lights and any other precautions for the safety of navigation in connection with such a bridge.

According to the Pesticide Control Act of 2005, 'pesticide certificate' means a document issued to a certified applicator, certified assistant or certified salesperson as defined in the regulations; 'watercourse' means the full length and width, including the sediment bed, bank and shore, of any stream, spring, creek, brook, river, lake, pond, bay, estuary or coastal water body or any part thereof, whether the same contains water or not. No person, whether or not acting under the authority of a license, pesticide certificate or permit under this Act or any exemption under the regulations, shall apply, discharge, or cause or allow the application or discharge of a pesticide or of any substance or thing containing a pesticide into the natural environment that pesticide:

- 1 causes or is likely to cause impairment of the quality of the natural environment greater than the impairment, if any, that would necessarily result from the proper use of the pesticide
- 2 causes or is likely to cause injury or damage to property or to plant or animal life greater than the injury or damage, if any, that would necessarily result from the proper use of the pesticide

- 3 causes or is likely to cause harm or discomfort to any person greater than the harm or discomfort, if any, that would necessarily result from the proper use of the pesticide
- 4 impairs or is likely to impair the safety of any person to a greater degree than the impairment, if any, of the safety of any person that would necessarily result from the proper use of the pesticide.

Where the Minister determines that any crop, food, feed, animal, plant, water, produce, product or other matter is contaminated by a pesticide, he may by order:

- 1 prohibit or restrict the sale, handling, use or distribution of the crop, food, feed, animal, plant, water, produce, product or other matter permanently or for such length of time as he considers necessary
- 2 cause the crop, food, feed, animal, plant, water, produce, product or other matter to be destroyed or rendered harmless, and no person shall be entitled to compensation therefore.

Where, having reasonable and probable grounds, the Director believes that the use, handling, storage, sale, disposal or display of, or the method of application or of transportation of, a pesticide or of a substance or thing containing a pesticide chemical control order:

- 1 causes or is likely to cause injury or damage to or impairment of the quality of the natural environment
- 2 causes or is likely to cause injury or damage to property or to plant or animal life
- 3 adversely affects or is likely to adversely affect the health or safety of any person
- 4 renders or is likely to render, directly or indirectly, any property or plant or animal life unfit for use by man

the Director may make an order called a 'chemical control order' directed to the person responsible for the pesticide or the substance or thing containing a pesticide, and shall cause a copy of the order to be served on the person to whom the order is directed.

Canada's Clean Air Act of 2006 and accompanying notice of intent to develop and implement Regulations and other measures to reduce air emissions outline a legislative agenda to reduce greenhouse gases and air pollution. They also purport to provide regulatory certainty for industry. Highlights of the Act and Notice of Intent include proposed amendments to the Canadian Environmental Protection Act (CEPA), the Motor Vehicle Fuel Consumption Standards Act and the Energy Efficiency Act to establish clear national standards:

- 1 move industry from voluntary compliance to legally enforceable regulations
- 2 monitor progress in reducing pollution and greenhouse gas emissions
- 3 require reporting to Canadians on that progress.

By between 2010 and 2015, the government intends to develop industrial intensity-based targets for reducing greenhouse gas emissions and fixed cap targets for air pollutants. By 2050, absolute reductions in greenhouse gas emissions to between 45% and

65% below 2003 levels are to be achieved. The government's stated long-term commitment to achieving such absolute reductions from 2003 levels represents a noted departure from the Kyoto Protocol's baseline year of 1990. It may give rise to concerns that a focus on 2003 is either arbitrary or may not accurately capture a relevant business cycle. National targets for levels of ozone and particulate matter will be developed. Also included are reporting requirements, particularly in the event of a contravention of the regulations, and whistleblower protections. The industrial sectors specifically identified as being subject to the new targets are essentially the same as those identified under previous proposals – the fossil-fuel fired electricity generation, upstream oil and gas, downstream petroleum, base metals, iron and steel, cement, forest products and chemicals production sectors. Three strategies will be used to reduce industrial air emissions:

- 1 emissions targets over the short, medium and long terms with a fixed cap for air pollutants and intensity-based targets for greenhouse gases (at least through the medium term)
- 2 a range of compliance options to optimize cost-effectiveness and flexibility on the part of industry
- 3 compliance assessment, monitoring and reporting with an emphasis (among other things) on harmonizing mandatory reporting among provinces and territories.

Table 5.2 Canada Acts (entry into force, main points and comments) for environment

Year	Title of Act	Main points	Comments
1970	Canada Water Act	<ul style="list-style-type: none"> ● This Act provides the management of the water resources of Canada ● This Act includes research and the planning and implementation of programs relating to the conservation, development and utilization of water resources 	> Canada Water Act was amended in 1985
1973–74	Canada Wildlife Act	<ul style="list-style-type: none"> ● This Act provides the protection of wild species and migratory birds 	> Canada Wildlife Act was amended in 1985 and the new Act specifies some points of the previous one
1978	Canada Shipping Act	<ul style="list-style-type: none"> ● Definitions (smoke, inspector etc.) ● Limits of smoke emission ● Density of smoke 	
1982	Coastal Fisheries Protection Act	<ul style="list-style-type: none"> ● Definitions (Canadian fisheries waters, Canadian fishing vessel etc.) ● Inspection, arrest, seizure and forfeiture 	
1985	Radiation Emitting Devices Act	<ul style="list-style-type: none"> ● An Act respecting the sale and importation of certain radiation emitting devices ● Definitions (radiation, package etc.) ● Disposition of devices with consent of owner 	
1985	Canada Hazardous Product Act	<ul style="list-style-type: none"> ● Definitions (hazardous product, inspector etc.) ● Prohibited and restricted products ● Controlled products 	
1992	Canadian Environmental Assessment Act	<ul style="list-style-type: none"> ● An Act to establish a federal environmental assessment process ● Federal environmental assessment coordinator 	

(Continued)

Table 5.2 (Continued)

Year	Title of Act	Main points	Comments
1997	Nuclear Safety and Control Act	<ul style="list-style-type: none"> ● Definitions (assessment by review panel, environment etc.) ● An Act to establish the Canadian Nuclear Safety Commission and to make consequential amendments to other Acts ● Definitions (nuclear energy, nuclear substance etc.) 	
1999	Canadian Environmental Protection Act	<ul style="list-style-type: none"> ● An Act respecting pollution prevention and the protection of the environment and human health in order to contribute to sustainable development ● Definitions (environment, fuel, environmental quality etc.) ● Environmental protection action ● Action to prevent or compensate loss 	
2001	Canada Foundation for Sustainable Development Technology Act	<ul style="list-style-type: none"> ● An Act to establish a foundation to fund sustainable development technology ● Definitions (eligible recipient, sustainable development etc.) ● Continuation of board of directors of corporation ● Member representation and experience 	
2002	Nuclear Fuel Waste Act	<ul style="list-style-type: none"> ● An Act respecting the long-term management of nuclear fuel waste ● Definitions (management, nuclear energy corporation, nuclear fuel waste etc.) ● Study and reports by waste management organization 	
2002	Pest Control Products Act	<ul style="list-style-type: none"> ● An Act to protect human health and safety and the environment by regulating products used for the control of pests ● Definitions (biotechnology, environment, pest control product, etc.) ● Registration of pest control products 	
2003	Environmental Management Act	<ul style="list-style-type: none"> ● Definitions (residential premises etc.) ● Hazardous waste management facility ● Hazardous waste storage disposal 	➤ Environmental Management Act repeals Waste Management Act of 1996
2004	Navigable Waters Protection Act	<ul style="list-style-type: none"> ● An Act respecting the protection of navigable waters ● Definitions (navigable water etc.) ● Regulation of ferry cables and swing or draw bridges 	
2005	Pesticides Control Act	<ul style="list-style-type: none"> ● Definitions (natural environment, pesticide certificate etc.) ● Chemical control order ● Licensing of pesticide services and vendors ● Pesticide, containers and storage 	
2006	Canada Clean Air Act	<ul style="list-style-type: none"> ● Clean Air Act is a legislative agenda to reduce greenhouse gases and air pollution ● It purports to provide regulatory certainty for industry ● Targets for emissions reduction 	

The government's ability to investigate releases of substances into the environment will be enhanced. An Environmental Damages Fund will be created to pool funds collected through fines paid by polluters. Regulations may specify the method of determining those fines. In addition, there will be penalties for failure to comply with emissions obligations (i.e. for failing to have sufficient credits or allowances available to reconcile against actual emissions to achieve the targets that will be imposed).

The main points and comments of the above Acts focused on the environment are summarized in Table 5.2.

References

US legislation

Federal Insecticide, Fungicide and Rodenticide Act

(<http://ipl.unm.edu/cwl/fedbook/fifra.html>)

National Environmental Policy Act

(<http://www.nepa.gov/nepa/regs/nepa/neaqia.htm>)

Occupational Safety and Health Act

(<http://www.dol.gov/compliance/guide/osha.htm>)

Clean Air Act

(<http://www.epa.gov/oar/caa/caa.txt>)

Clean Water Act

(http://www.access.gpo.gov/uscode/title33/chapter26_.html)

Marine Protection, Research and Sanctuaries Act

(<http://epw.senate.gov/mprsa72.pdf>)

Coastal Zone Management Act

(http://www.cr.nps.gov/local-law/FHPL_CstlZoneMngmt.pdf)

Endangered Species Act

(<http://www.fws.gov/endangered/esa.html>)

Safe Drinking Water Act

(<http://www.osha.gov/dep/oia/whistleblower/acts/sdwa.html>)

Hazardous Materials Transportation Act

(<http://www.legislature.mi.gov/documents/mcl/pdf/mcl-Act-138-of-1998.pdf>)

Resource Conservation and Recovery Act

(<http://ipl.unm.edu/cwl/fedbook/rcra.htm>)

Toxic Substances Control Act

(<http://www.osha.gov/dep/oia/whistleblower/acts/tsca.html>)

Surface Mining Control and Reclamation Act

(<http://ipl.unm.edu/cwl/fedbook/smcra.html>)

Uranium Mill Tailings Radiation Control Act

(http://www.eoearth.org/article/Uranium_Mill_Tailings_Radiation_Control_Act_of_1978,_United_States)

Comprehensive Environmental Resource, Compensation and Liability Act

(<http://www.epa.gov/superfund/action/law/cercla.htm>)

Low Level Radioactive Policy Act

(<http://sec.edgar-online.com/1997/03/14/00/0000008192-97-000012/Section3.asp>)

Superfund Amendments and Reauthorization Act

(<http://fema.gov/government/grant/sara.shtm>)

Soil Conservation and Land Care Act

(http://www.dwlbc.sa.gov.au/assets/files/Soil_Conservation_Land_Care_Act_1989.pdf)

Oil Pollution Act

(<http://epw.senate.gov/opa90.pdf>)

Pollution Prevention Act

(<http://www.epa.gov/oppt/p2home/pubs/p2policy/act1990.htm>)

Federal Facility Compliance Act

(http://www.epa.gov/swerffrr/documents/federal_facility_compliance_act.htm)

Nuclear Waste Policy Act

(<http://epw.senate.gov/nwpa82.pdf>)

Clean Smokestacks Act

(http://www.sustainableenergy.org/resources/policy/legislation/waxman_bill.htm)

Environmental Management Act

(http://www.ema.co.tt/docs%5Clegal%5Ccur%5CAct_3_of_2000.pdf)

Climate Stewardship Act

(http://www.columbia.edu/cu/mpaenvironment/pages/projects/CSA_FINAL_REPORT%20f03.pdf)

Canada legislation

Canada Water Act

(<http://lois.justice.gc.ca/en/c-11/text.html>)

Canada Wildlife Act

(<http://schoolnet.ca/aboriginal/treaties/wildlife-e.html>)

Canada Shipping Act

(<http://www.tc.gc.ca/acts-regulations/GENERAL/C/csa/regulations/001/csa002/csa2.html>)

Coastal Fisheries Protection Act

(<http://lois.justice.gc.ca/en/c-33/228885.html>)

Radiation Emitting Devices Act

(<http://lois.justice.gc.ca/en/r-1/text.html>)

Canada Hazardous Product Act

(http://www.unitar.org/cwg/publications/cbl/ghs/Documents/cat4/National/Canada_Haz_Products_Act.pdf)

Canadian Environmental Assessment Act

(<http://lois.justice.gc.ca/en/C-15.2/text.html>)

Nuclear Safety and Control Act

(<http://lois.justice.gc.ca/en/n-28.3/252272.html>)

Canadian Environmental Protection Act

(<http://lois.justice.gc.ca/en/c-15.31/text.html>)

Canada Foundation for Sustainable Development Technology Act

(<http://lois.justice.gc.ca/en/c-5.5/231997.html>)

Nuclear Fuel Waste Act

(<http://lois.justice.gc.ca/en/n-27.7/text.html>)

Pest Control Products Act

(<http://lois.justice.gc.ca/en/P-9.01/text.html>)

Environmental Management Act

(http://leg.bc.ca/37th4th/3rd_read/gov57-3-pt02.htm)

Navigable Waters Protection Act

(<http://lois.justice.gc.ca/en/n-22/251715.html>)

Pesticides Control Act

(<http://www.gov.pe.ca/law/statutes/pdf/p-04.pdf>)

Canada Clean Air Act

(<http://www.osler.com/resources.aspx?id=11449&tracklinkSP=SPOTRecentOslerUpdate>)

Scientific references

Culley, W.C. (1998). *Environmental and quality systems integration*, pp. 13–22. Lewis Publishers.

Ray, B.T. (1995). *Environmental engineering*, pp. 348, 389, 428. PWS Publishing Company.

Ritchie, I. and Hayes, W. (1998). *A guide to the implementation of the ISO 14000 series on environmental management*, pp. 202–203. Prentice Hall PRT.

e-addresses

<http://www.grrn.org/resources/BevEPR.html>

http://www.ucowr.siu.edu/updates/pdf/V113_A5.pdf

<http://www.eia.doe.gov/emeu/cabs/usenv.html>

http://en.wikipedia.org/wiki/Montreal_Protocol

This page intentionally left blank

Waste Treatment Methodologies

PART

3

6 Food Waste Treatment Methodologies

345

This page intentionally left blank

Food Waste Treatment Methodologies

Ioannis S. Arvanitoyannis, Aikaterini Kassaveti, Demetrios Ladas

Introduction	345
Treatment methods	359

Introduction

Since food industries produce a substantial amount of pollution, it is becoming more and more imperative to solve this problem. As the constraints related to environmental issues are becoming quite stringent, it is necessary to develop optimized systems for food waste treatment. Among the several biological and chemical processes in this chapter, the following are described: composting, anaerobic digestion, aerobic digestion, thermophilic anaerobic digestion, sequencing batch reactor, electrodialysis, wet oxidation, pyrolysis, incineration, solid state fermentation and ozonation. Most of them have a high capacity to degrade concentrated and difficult substrates (plant residues, animal wastes, food industry wastewater and so forth). Table 6.1 presents the literature about treatment methods of food waste and Table 6.2 summarizes the advantages, disadvantages, velocity rate, cost, duration and effectiveness of these methods.

Through the measures of the Waste Framework Directive (1975) as amended in 1991 and 1996, the Member States of the European Union are required to have a National Waste Strategy that sets out their policies in relation to the recovery and disposal of waste. The objectives of the National Strategy of Member States (Environmental Act 1995; Lane and Peto, 1995; Gervais, 2002) include:

- 1 ensuring that waste is recovered or disposed of without endangering human health and without using processes or methods which could harm the environment
- 2 establishing an integrated and adequate network of waste disposal installations, taking account of the best available technology but not involving excessive costs
- 3 ensuring self-sufficiency in waste disposal
- 4 encouraging the prevention or reduction of waste production and its harmfulness by the development of clean technologies
- 5 encouraging the recovery of waste by means of recycling, re-use or reclamation and the use of waste as a source of energy.

Table 6.1 Treatment methodology of food waste

No	Kind of waste	Treatment	Parameters	Methodology	Results	References
1	Wastewater	Anaerobic digestion	Density, fluidization velocity, TOC, HRT, TSS, VSS, VFA	In down-flow fluidization, particles with a specific density smaller than the liquid are fluidized downward by a concurrent flow of liquid	85% TOC removal Low energy requirement No need for a settling device	Garcia-Calderon <i>et al.</i> , 1998
2	Wastewater	Ozonation	$C_A \cdot 10^4$, S_0 , S_f , X_S , $k \cdot 10^2$, k	The ozonation experiments were conducted in a 1000 cm ³ batch reactor at 6 different conditions	2.59–4.56 mol/l $C_A \cdot 10^4$, 24.5–27.4 g/l S_0 , 20.1–24.7 g/l S_f , 15.3–26.5% X_S , 2.92–5.06/h/k10 ² , 64–196 l/(mol/h) k	Benitez <i>et al.</i> , 1999
3	Wastewater	Thermophilic anaerobic digestion	COD, biogas specific productivity, pH, total solids, temperature	A full-scale plant using thermophilic (50–55°C) anaerobic digestion of wastewaters	Biogas production 2.5 m ³ /m ³ _{reactor} day Methane production 0.4 m ³ /kg COD removal Conversion of organic solids to CH ₄ 70% and mean CO ₂ content of biogas 18%	Vlissidis and Zouboulis, 1993
4	Wastewater	Ozonation	COD, pH, total solids, UV radiation, ozone partial pressure, BOD ₅	The ozonation experiment was conducted in a 1000 cm ³ glass column with outlets for sampling and vending	5–25% removal of COD 16.8–51.4% removal of the total aromatic compounds	Benitez <i>et al.</i> , 2003
5	Wastewater	Aerobic biodegradation	COD, pH, total solids, BOD ₅ , Hydraulic retention time	Activated sludge system, comprising an aeration reactor and a clarifier	31–85% removal of COD	Benitez <i>et al.</i> , 2003
6	Wastewater	Thermophilic anaerobic digestion	COD, F:M ratio, ORL, TSS, biogas rate production	Biodegradation of wastewater in laboratory bed reactor with a porous medium	>82.5% COD reduction at a COD loading 32.3 kgCOD/m ³ /day	Perez <i>et al.</i> , 2001
7	Wastewater	Sequencing batch reactor	COD (total), BOD ₅ , COD (soluble), nitrogen concentration, total phosphorus concentration	Sequencing batch reactor operation during one cycle (24 h)	93% COD (total) 95% COD (soluble) 97.5% BOD ₅	Torrijos and Moletta, 1997

8	Wastewater	Sequencing batch reactor	COD (total), TSS	1-3 cycles/day effluent contains 50-184 mg of COD/l and 58-83 mg of TSS/l	97% COD	Houbron <i>et al.</i> , 1998
9	Wastewater	Electrodialysis	Tartaric acid concentration, malic acid concentration	Wastewater has been electrodialed at 60°C, cooled at 5°C for 48 h and re-electrodialyzed with the aim producing secondary precipitation	The cold storage of primary and secondary eliminates, respectively, 80% and 87% of tartaric acid, 15% and 14% of malic acid	Smagge <i>et al.</i> , 1992
10	Wastewater	Ozonation	COD, COD (soluble), BOD ₅ , TOC (soluble), pH, phenols concentration, IC (soluble)	Glass reactor with 2 dm ³ wastewater	80% phenol content reduction, 16% decrease in organic load	Santos <i>et al.</i> , 2003
11	Wastewater	Ozonation	Phenolic acids concentration (caffeic acid, <i>p</i> -coumaric acid, syringic acid, vanillic acid)	Ozonation of wastewaters at two reaction times (20 and 40 min), at pH 7 and 20°C	Conversion of caffeic acid (76.3-93.1%) Conversion of <i>p</i> -coumaric acid (69.4-98.9%) Conversion of syringic acid (73.8-97%) Conversion of vanillic acid (69-97.4%)	Benitez <i>et al.</i> , 1997
		Combined ozonation-UV radiation		Ozonation-UV radiation of wastewaters at two reaction times (20 and 40 min), at pH 7 and 20°C	Conversion of caffeic acid (88.8-100%) Conversion of <i>p</i> -coumaric acid (86.7-100%) Conversion of syringic acid (84.3-100%), Conversion of vanillic acid (75.3-98.5%)	
12	Wastewater	Ozonation	COD, pH, TOC, TKN, UV ₂₅₄ , polyphenols content	Wastewaters were treated by semi-batch and continuous pH sequential ozonations	24% COD removal 13% TKN removal 17% TOC removal 21% UV ₂₅₄ removal	Beltran <i>et al.</i> , 2001
		Integrated activated sludge system (ASP)-ozonation		Combination of activated sludge system (biological oxidation) with continuous pH sequential ozonations	77.9-77.5% BOD removal (ASP) and 6% BOD removal (ozonation), 45.5-46.9% COD removal (ASP)	

(Continued)

Table 6.1 (Continued)

No	Kind of waste	Treatment	Parameters	Methodology	Results	References
13	Wastewater	Wet oxidation	Homogeneous and heterogeneous catalysts, <i>p</i> -coumaric acid concentration, temperature, oxygen partial pressure, TOC	Catalytic oxidation of <i>p</i> -coumaric acid in a stainless steel high pressure reactor	90–100% destruction of <i>p</i> -coumaric acid (30 min) 50% decrease of TOC (5–10 min)	Mantzavinos <i>et al.</i> , 1996
14	Wastewater	Wet oxidation	<i>p</i> -coumaric acid concentration, temperature, oxygen partial pressure, TOC	Batch oxidation of <i>p</i> -coumaric acid in a stainless steel high pressure reactor at temperatures from 403–523 K and pressures from 3 to 7 MPa	90% destruction of, <i>p</i> -coumaric acid after 60 min, 20% decrease of TOC	Mantzavinos <i>et al.</i> , 1996
15	Wastewater	Anaerobic digestion	Temperature, pH, COD, hydraulic retention time, flow rate	A bench-scale anaerobic hybrid filter (AHF) for the anaerobic digestion of wastewater	0.65–0.90 COD removal at low hydraulic retention time (2–3 days)	Berardino <i>et al.</i> , 2001
16	Wastewater	Aerobic digestion	COD, phenolic compounds concentrations	1200 ml mixed batch reactor submerged in a thermostatic bath	90% COD removal, 66–79% total phenolic compounds removal	Benitez <i>et al.</i> , 1999
		Anaerobic digestion		Experiments in duplicate in 1000 ml magnetically stirred batch anaerobic digestion units	100% removal of substrate, gas formation averaging 199 ml CH ₄ /g COD degraded	

Adapted from Arvanitoyannis *et al.*, 2006b. BOD, biological oxygen demand (g/l); COD, chemical oxygen demand (g/l); HRT, hydraulic retention times; ORL, organic loading rate; TKN, total kneldahl nitrogen ($\mu\text{g/l}$); TOC, total organic carbon (kg/m^3); TSS, total suspended solids (kg/m^3); VFA, volatile fatty acids (kg/m^3); VSS, volatile suspended solids (kg/m^3)

Table 6.2 Waste treatment methodologies: advantages, disadvantages, velocity rate, cost, duration and effectiveness

No	Treatment	Advantages	Disadvantages	Velocity rate	Cost	Duration	Effectiveness	References
1	Anaerobic digestion	Low energy consumption, low nutrient requirements, less production of stabilized sludge, high capacity to degrade concentrated and difficult substrates, recovery of energy using methane combustion, operational ability in short hydraulic times	Unstable under variations of the operating conditions, complexity, high variability of the input load, high non-linear nature of the process, lack of appropriate sensors to monitor the variables	Low	Low	Continuous	High	Berardino <i>et al.</i> , 2001 Bernard <i>et al.</i> , 2001 Aubrun <i>et al.</i> , 2000 Genovesi <i>et al.</i> , 1999 Estaben <i>et al.</i> , 1997 Berardino <i>et al.</i> , 1997 Galderon <i>et al.</i> , 1998 Mendez-Acosta <i>et al.</i> , 2004
2	Incineration	Max volume reduction, low disposal requirements, destruction of pathogens and toxic compounds, energy recovery, no methane production	Emission of micro- and macro-pollutants, occasional liquid effluent, release to be treated before being discharged to sewers	High	High capital and operating cost	Continuous and discontinuous	High	Mariani <i>et al.</i> , 1992 Leckner and Lynfelt, 2002
3	Ozonation	No by-products to be removed, ozone presence desirable properties like: powerful oxidant, soluble in water, readily available and high selectivity	Complex process	Slow kinetic regime	High	Continuous and discontinuous	Median to high	Beltran <i>et al.</i> , 2001 Santos <i>et al.</i> , 2003 Benitez <i>et al.</i> , 1997, 1999, 2003
4	Sequencing batch reactor	Lower cost than conventional biological treatment methods, easier to control filamentous growth and settling problems, less equipment requirement, greater operator flexibility, no biomass washing out, bad	A higher level of sophistication (timing units and controls) than conventional systems, potential of discharging floating or settled sludge during the draw or decantation phase, potential required	Low	Low	Discontinuous	High	Mace and Mata-Alvarez, 2002 Torrijos and Moletta, 1997 Houbron <i>et al.</i> , 1998

(Continued)

Table 6.2 (Continued)

No	Treatment	Advantages	Disadvantages	Velocity rate	Cost	Duration	Effectiveness	References
5	Solid-state fermentation	setling is recognizable and corrected, possible addition of activated carbon Favorable conditions for the fungi growth, by-products as source of human and microbe food, ecological benefits, low contamination possibilities by bacteria and yeast	equalization depending on the downstream processes Only microorganisms that grow at low moisture levels can be used, biomass determination is very difficult, undesirable viscous products after leaching fermented solids, inoculum volumes required, very difficult agitation	Low	Low	Continuous and discontinuous	High	Sanchez <i>et al.</i> , 2002 Bustos <i>et al.</i> , 2004 Israilides <i>et al.</i> , 1998 Moldes <i>et al.</i> , 2003 Arapoglou <i>et al.</i> , 2002 Perez <i>et al.</i> , 2003
6	Thermophilic anaerobic digestion	Stability, high efficiency, low nutrient requirements, efficient biogas production, high purification degree with high organic load feeds	High energy requirements for heating, super mutant containing larger quantities of dissolved solids and odors	High rate	Low operational cost	Continuous	High	Perez <i>et al.</i> , 2001 Vlissidis and Zouboulis, 1993 Converti <i>et al.</i> , 1999 Gallert and Winter, 1997
7	Electrodialysis	Easy development at industrial scale, no addition of external compounds, simultaneous concentration-purification process	Maximum impurities amount	Median	High operational cost	Continuous	High	Andres <i>et al.</i> , 1997 Smagge <i>et al.</i> , 1992 Decloux <i>et al.</i> , 2002
8	Aerobic biodegradation	Flexibility, easy operation, recovery of more of the basic fertilizer values in the sludge, production of an odorless, humus like, biologically stable end product, economically, high biomass production	Operational difficulties of sludge, bulking inability of the system to treat high BOD or COD loads	Low	High cost in terms of energy, lower capital cost	Continuous and discontinuous	High	Benitez <i>et al.</i> , 1999, 2003 Metcalf and Eddy, 1991

9	Wet oxidation	Lower production of toxic degradation products, considerable decrease of cellulose crystallinity, high delignification potential	Waste must be in the liquid phase, limited to wastewaters with oxidizable organic and inorganic compounds.	High	High	Discontinuous and continuous	High	Mantzavinos <i>et al.</i> , 1996 Lissens <i>et al.</i> , 2004
10	Pyrolysis	Gas/liquid for energy production, low demand for landfill and other waste management capacity	Difficult heat transfer to feedstock, difficult control of product quality, a high level of commitment to pyrolysis may inhibit waste minimization and recycling	High	High cost	Continuous	High	Encinar <i>et al.</i> , 1996, 1997 Yaman, 2004 Meier and Faix, 1999 Shinogi and Kanrib, 2003
11	Composting	Flexibility, short-term requirements, minimization of nuisance odors, by-product as fertilizer, high level of stability	Expensive operation, difficult to find disposal sites, toxic degradation products, plant growth inhibition, toxic leaching	Low	High operational cost	Continuous	High	Diaz <i>et al.</i> , 2002 Madejon <i>et al.</i> , 2001 Kulku and Yaldiz, 2004 Manios, 2004 Inbar <i>et al.</i> , 1988, 1992 Ranalli <i>et al.</i> , 2001 Ferrer <i>et al.</i> , 2001 Ingelmo <i>et al.</i> , 1998

Adapted from Arvanitoyannis *et al.*, 2006b

Table 6.3 Proximate analysis and caloric values (kJ/kg) of municipal solid waste components

Component	Proximate analysis				Caloric values		
	Moisture	Ash	Volatiles	Fixed carbon	Moisture/ash free	As received	Dry
Paper-mixed	10.24	5.38	75.94	8.44	18 650	15 750	17 530
Corrugated boxes	5.20	5.06	77.47	12.27	18 260	16 380	17 280
Plastic coated paper	4.71	2.64	84.20	8.45	18 470	17 070	17 910
Waxed milk cartons	3.45	1.17	90.92	4.46	27 660	26 350	27 290
Vegetable food waste	78.29	1.06	17.10	3.55	20 230	4 170	19 230
Meat scraps (cooked)	38.74	3.11	56.34	1.81	30 490	17 730	28 940
Fried fats	0.00	0.00	97.64	2.36	38 300	38 300	38 300
Polystyrene	0.20	0.45	98.67	0.68	38 230	38 020	38 090
PVC	0.20	2.06	86.89	10.85	23 160	22 590	22 640

Adapted from Williams, 2005

The analysis of the components of municipal solid waste (Table 6.3) show that the caloric value, ultimate and proximate analyses of even different sorts of paper, food and household waste, can be different. The processes of degradation of organic bio-reactive waste in landfills involve not only biological processes, but also interrelated physical and chemical processes. The organic components of the waste are degraded by microorganisms in the landfill. The organic materials occurring in waste can be classified into broad biological groups represented by proteins, carbohydrates and lipids or fats. Carbohydrates are by far the major component of biodegradable wastes and include cellulose, starch and sugars. Proteins are large complex organic materials composed of hundreds or thousands of amino acids groups. Lipids or fats are materials containing fatty acids. Five main stages of degradation of biodegradable wastes have been identified (Kjeldsen *et al.*, 2002). Landfilling consists of five stages:

- 1 hydrolysis/aerobic degradation
- 2 hydrolysis and fermentation
- 3 acetogenesis
- 4 methanogenesis
- 5 oxidation.

There are numerous factors influencing the degradation of the waste and these have been reviewed by Westlake (1995) and Christensen *et al.* (1996). Among them, the most important ones are: site characteristics, waste characteristics, moisture content of the waste, temperature and acidity. The modern site is seen in this context as a 'bioreactor', used to stabilize waste and produce landfill gas for energy recovery. Estimates of the amount of landfill gas generated throughout the lifetime of the landfill site are highly variable with estimates of between 39 and 500 m³/tonne (McBean *et al.*, 1995). For the estimation of landfill gas throughout the lifetime of a site for the assessment of energy recovery from landfill gas utilization, values of between 150 and

Table 6.4 Physical assessment techniques to estimate landfill gas generation

Technique	Basis	Advantages	Disadvantages
Waste sampling from trial pits and boreholes	Qualitative assessment of nature of waste by inspection	Low cost Useful information about nature and location of wastes	Samples may not be representative
Waste analysis	Chemical analysis of waste samples Samples incubated in the laboratory can be used for gas generation	Low cost Useful information about nature and location of wastes	Samples may not be representative
Measurement of passive landfill gas emissions	Measurement of flow of landfill gas from boreholes or into flux boxes installed within the landfill	Measures landfill gas generated under field conditions	Errors in the scale-up computation Atmospheric pressure influences flow
Pumping trials	Pulping of landfill gas from boreholes until steady state is achieved with estimate of volume of waste affected by measuring pressure drop in the landfill	Measures landfill gas generated under field conditions	High cost Measurements of the radius of influence can lack precision

Adapted from Williams, 2005

250 m³/tonne are typically used (Loening, 2003). Physical assessment techniques to estimate landfill gas generation are given in Table 6.4.

As an alternative to landfill, wastes containing combustible material may be incinerated or combusted. Incineration is the oxidation of the combustible material in the waste to produce heat, water vapor, nitrogen, carbon dioxide and oxygen. Depending on the composition of the waste, other emissions may be formed, including carbon monoxide, hydrogen chloride, hydrogen fluoride, nitrogen oxides, sulfur dioxide, volatile organic carbon, dioxins and furans, polychlorinated biphenyls, heavy metals, etc. (European Commission, 2004). Incineration is a treatment route which can be applied to a wide variety of wastes. Incineration of waste has a number of advantages over landfill:

- 1 incineration can usually be carried out near the point of waste collection
- 2 the waste is reduced to a biologically sterile ash product which, for municipal solid waste, is approximately 10% of its pre-burnt volume and 33% of its pre-burnt weight
- 3 incineration produces no methane, unlike landfill
- 4 waste incineration can be used as a low cost source of energy
- 5 the bottom ash residues can be used for material recovery or secondary aggregates in construction
- 6 incineration is the best practicable environmental option for hazardous wastes.

However, there are also disadvantages:

- 1 much higher costs and longer pay-back periods
- 2 lack of flexibility

- 3 removal of materials such as paper and plastics for recycling may reduce the overall caloric value of the waste
- 4 emitted levels may still have an adverse effect on health.

Pyrolysis is the thermal degradation of organic waste in the absence of oxygen to produce a carbonaceous char, oil and combustible gases. How much of each product is produced is dependent on the process conditions, particularly temperature and heating rate. The key difference is the amount of oxygen supplied to the thermal reactor. For pyrolysis there is an absence of oxygen and for gasification there is a limited supply of oxygen such that complete combustion does not take place, instead the combustible gases carbon monoxide and hydrogen are produced. The oxygen for gasification is supplied in the form of air, steam or pure oxygen. Incineration involves the complete oxidation of the waste in an excess supply of oxygen to produce carbon dioxide, water and ash, plus some other products such as metals, trace hydrocarbons, acid gases etc. (Menachem and Goklestein, 1984; Williams, 2005). Relatively low temperatures are used for pyrolysis, in the range 400–800°C (Bridgwater and Bridge, 1991).

Developments in thermochemical processing of waste have utilized both pyrolysis and gasification in combined technologies, which may then involve a further combustion step to combust the gases produced in the two stages. Such pyrolysis/gasification/combustion technologies are, in effect, incinerators, but each step is separated into a separate temperature and pressure controlled reactor rather than in an incinerator, where the three thermal degradation steps are combined in a one-step grate combustion system. The de-coupling of the thermal degradation steps has the advantage of flexibility in determining which targeted end product is best suited to each application. Further advantages include the option that the product gas may be cleaned to remove acid gases prior to the combustion of the gas for energy recovery. These results are reduced high temperature corrosion within the energy recovery system. Furthermore, pyrolysis/gasification systems produce significantly reduced gas volumes for cleanup compared with a conventional waste incinerator, resulting in scale-down of the gas cleaning system and consequent reduction in cost (Williams, 2001; Whiting, 2001, 2003).

The purpose of sludge digestion is to convert bulky, odorous sludges to a relatively inert material that can be rapidly dewatered without obnoxious odors. The bacterial process consists of two successive processes that occur simultaneously in digesting sludge. The first stage consists of breaking down large organic compounds and converting them to organic acids along with gaseous by-products of carbon dioxide, methane and trace amounts of hydrogen sulfide. Two digesters in series separate the functions of biological stabilization from gravity thickening and storage. The first-stage high-rate unit is completely mixed and heated for optimum bacterial decomposition (Harrison, 2000; Hammer and Hammer, 2004). These systems are available for installation in either fixed- or floating-cover tanks. Biological tower filtration can be combined with second stage aeration to improve treatment, particularly for municipal wastewaters with variable strength resulting from contributions of high strength industrial or seasonal wastes. These processes can be operated with various flow patterns as shown in Figure 6.1. Waste sludge can be stabilized by long-term aeration that biologically destroys volatile solids. The aerobic digestion process was developed

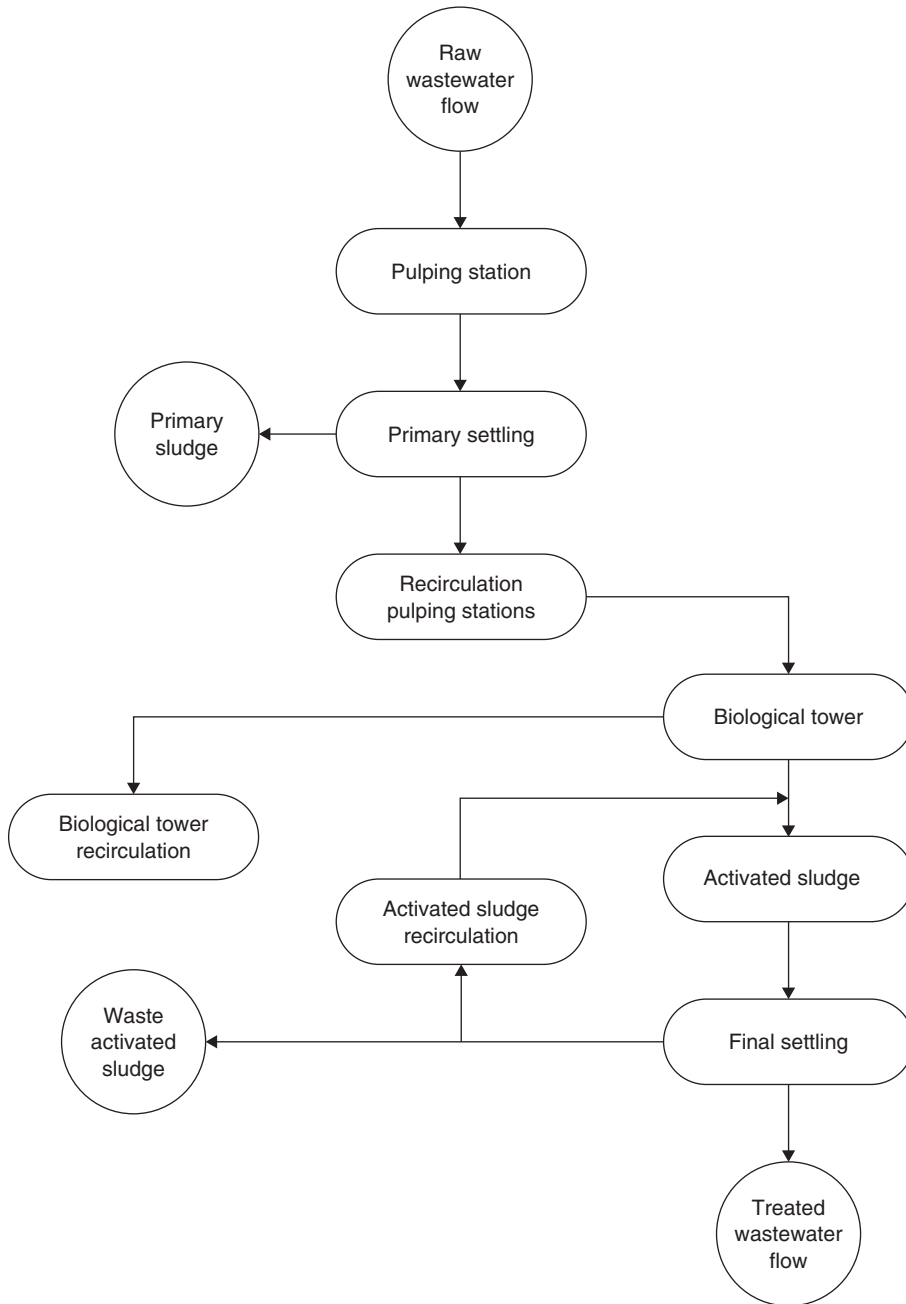

Figure 6.1 Profile of the combined filtration and aeration process with direct recirculation through the tower and recirculation of activated sludge from the bottom of the final classifier (adapted from Hammer and Hammer, 2004)

specifically to handle excess activated sludge from aerobic treatment plants without primary classifiers. High water content, in the range of 98–99%, also prevented economical dewatering by mechanical means without prior thickening. Consequently, aerated holding tanks were introduced to stabilize and store mixed liquor drawn from

the aeration tank. Aerobic digesters are single or multiple tanks equipped with diffused or mechanical aerators.

Composting is the aerobic, rather than anaerobic, biological degradation of biodegradable organic waste, such as garden and food waste. Composting is a relatively fast biodegradation process, taking typically about 4–6 weeks to reach a stabilized product. Composting is practiced on a small scale at the individual household level and on a large-scale via composting schemes, where the organic waste collected from parks, household garden waste collected from civic amenity sites and garden and food waste collected directly from households in separate kerbside collection is processed (McLanaghan, 2002). Composting removes a large part of the organic biodegradable waste from the waste stream and in its way helps to fulfill the obligations placed on Member States of the EU in meeting the requirements of the EC Waste Landfill Directive (1999). The composting process for municipal solid waste involves a number of stages which are shown in Figure 6.2 (McLanaghan, 2002). The initial stage involves collection of the waste as source-segregated waste by the householder, where segregation of the biodegradable fraction is made through kerbside collection or ‘bring’ schemes. The main factors influencing composting are:

- 1 suitable oxygen
- 2 temperature: maximum microorganism activity is observed at 30–35°C
- 3 moisture content: below a minimum 40%
- 4 pH range 5.5–8
- 5 C:N ratio of the waste material: optimal C:N ratio in the starting waste material is about 25
- 6 size range of waste material (De Bortoldi *et al.*, 1983).

Composting is the stabilization of moist organic solids by natural biological processes when the organic matter is placed in piles that allow ventilation. The optimum moisture content for a compost mixture is 50–60%. For efficient stabilization and pasteurization, the temperature in a compost pile should rise to a level of 55–65°C (130–150°F) but not above 80°C (176°F). Composting temperature is influenced by moisture content, degree of aeration, size and shape of material and rainfall. The finished compost is friable humus with a moisture content less than 40%. Sludge cake for composting is usually raw organic solids dewatered using polymer as a conditioning chemical, although partially digested sludge may also be composed for additional stabilization. Incineration is an extension of the drying process and converts solids into an inert ash that can be disposed of easily. If dewatered to approximately 35% solids, the process is usually self-sustaining without supplemental fuel, except for initial warm-up and heat control. It is generally preferable to burn raw rather than digested sludge because of its higher heat value.

Odors result from the generation of hydrogen sulfide, release of organic compounds and other vapors. Odor control equipment includes adsorption systems, biological systems and wet scrubbers (Hammer and Hammer, 2004). The process diagram for a typical activated-sludge plant in Figure 6.3 suggests a minimum testing program for plant evaluation. Influent and effluent monitoring routinely requires testing for composite biochemical oxygen demand (BOD), suspended solids (SS) concentrations and pH.

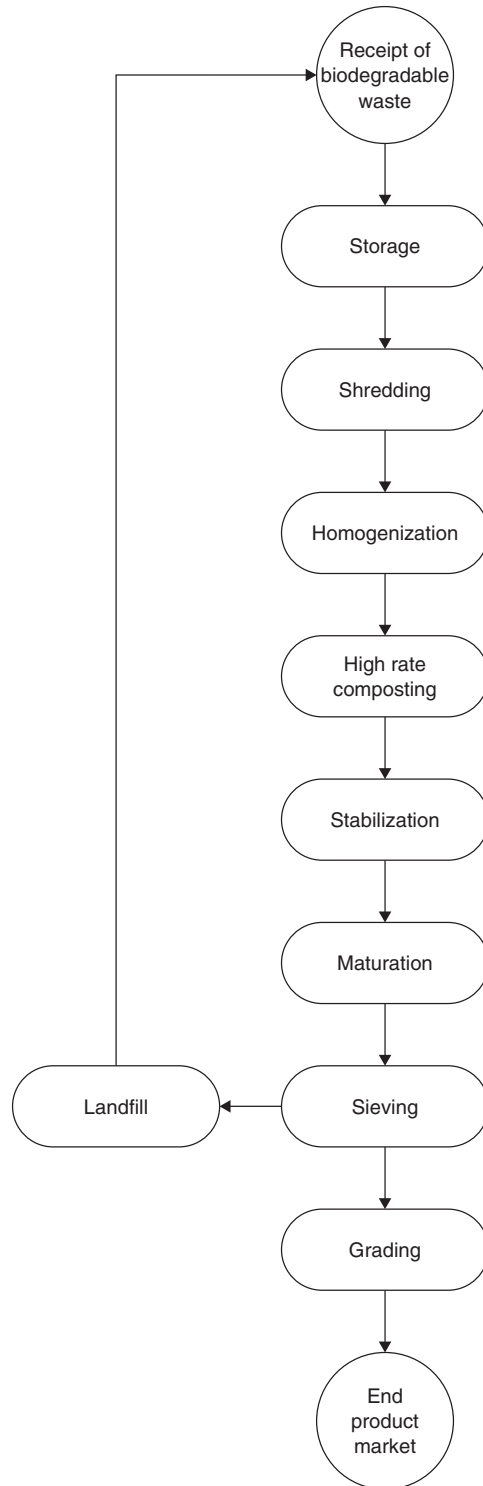

Figure 6.2 Schematic diagram of the composting process (adapted from McLanaghan, 2002; Swan *et al.*, 2002; Williams, 2005)

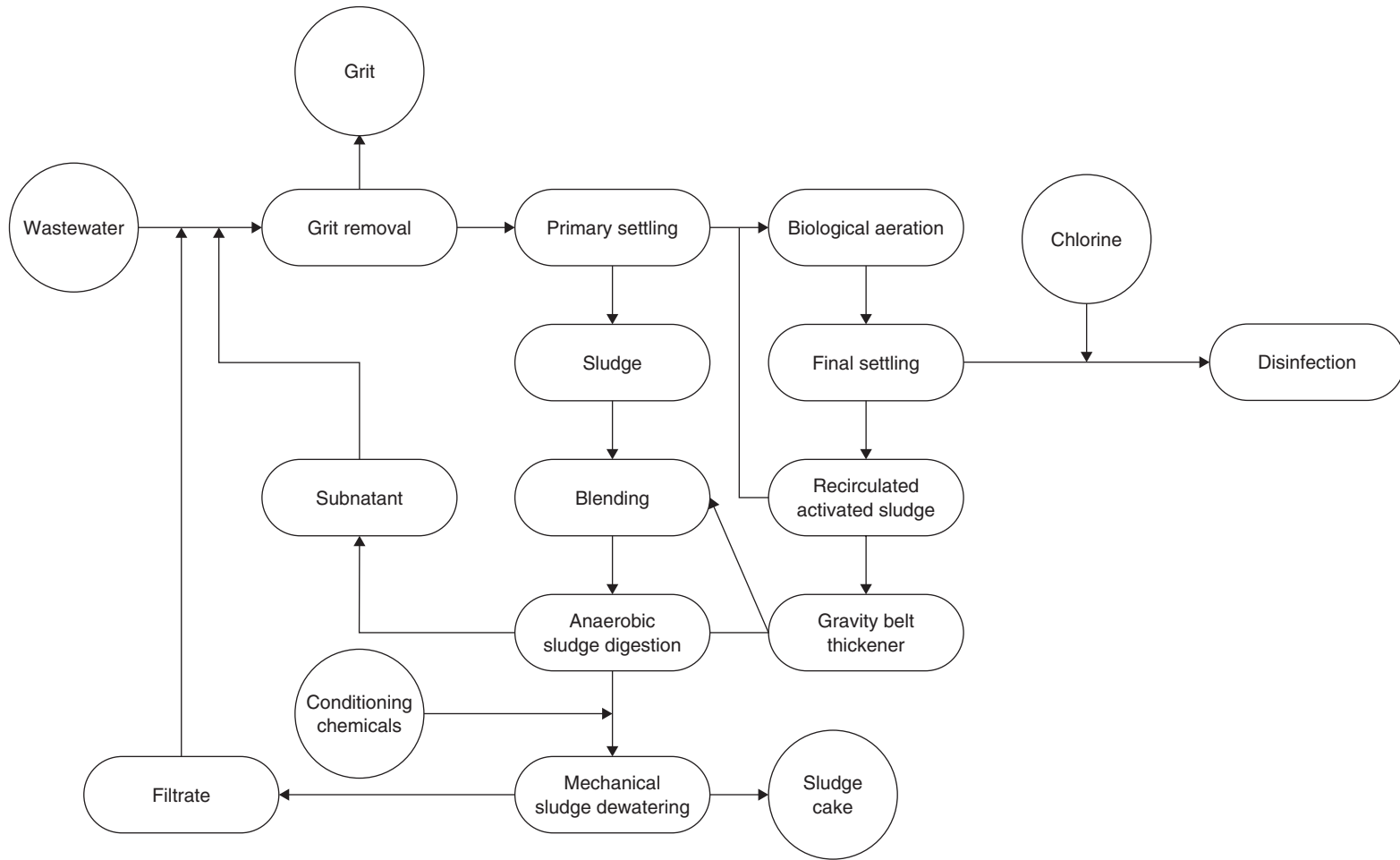

Figure 6.3 Diagram for wastewater treatment by conventional activated sludge showing interrelated unit processes (adapted from Hammer and Hammer, 2004)

Treatment methods

Bioremediation technologies can be classified as *in-situ* or *ex-situ*. *In-situ* bioremediation treats the contaminated water or soil where it was found, whereas *ex-situ* bioremediation processes involve removing the contaminated soil or water to another location prior to treatment (<http://www.cpeo.org/techtree/ttdescript/ensolmx.htm>).

Ex-situ bioremediation

Ex-situ techniques can be more rapid, easier to control and used to treat a wider range of contaminants and soil types than *in-situ* techniques. However, they require excavation and treatment of the contaminated soil before and, sometimes, after the actual bioremediation step (<http://www.modflow.bossintl.com/html/exsitu-bioremediation.html>). *Ex-situ* techniques include slurry-phase bioremediation (bioreactors) and solid-phase bioremediation (landfarming, composting, biopiles).

Slurry-phase bioremediation The term ‘bioreactor’ in the context of soil and water bioremediation refers to any vessel or container where biological degradation of contaminants is isolated and controlled. Bioreactors can range from crude devices such as lined depressions in the ground to advanced metal containers where environmental conditions can be continuously monitored and controlled (<http://ewr.cee.vt.edu/environmental/teach/gwprimer/bioreact/bior.html>).

Contaminated soil is blended with water and other additives in a large tank to keep the microorganisms – which are already present in the soil – in contact with the soil contaminants. Nutrients and oxygen are added and conditions in the bioreactor are controlled to create the optimum environment for the microorganisms to degrade the contaminants. Upon completion of the treatment, the water is removed from the solid and the latter is disposed of or further treated if it still contains hazardous pollutants (<http://www.icar.cnr.it/spezzano/colombo/bioris/cortesto.htm>). Bioreactors for ground-water treatment are usually either fixed films or some form of activated sludge reactors. Fixed films reactors contain high surface area media capable of supporting microbial growth. Activated sludge reactors are aerated basins where microbes are thoroughly mixed with the wastewater and nutrients. Bioreactors can be operated either in batch or steady state flow regimes (<http://ewr.cee.vt.edu/environmental/teach/gwprimer/bioreact/bior.html>).

This technology is particularly useful and effective where rapid remediation is a top priority (<http://www.modflow.bossintl.com/html/exsitu-bioremediation.html>).

Solid-phase bioremediation

Landfarming Landfarming is the spreading and incorporation of waste into the soil to initiate biological treatment (http://www.aimsconsulting.com/resources/Resource_Library.html). Contaminated sludge, soils or sediments are spread on fields and cultivated in the same way as a farmer might plough and fertilize agricultural land. The soil is periodically turned over to mix air into the waste. Moisture and nutrients are

controlled in order to enhance bioremediation (<http://www.modflow.bossintl.com/html/exsitu-bioremediation.html>). Although its application is restricted to readily degradable material, leaching into groundwater is still a real threat (<http://www.biotech-monitor.nl/3405.htm>).

Composting

There are three process designs used in composting:

- 1 *Aerated static pile composting*: compost is formed into piles and aerated with blowers or vacuum pumps (http://www.frtr.gov/matrix2/section4/4_13.html). The aerated static pile method of composting was developed in the mid-1970s to reduce land area requirements and to resolve other problems associated with the turned windrow method (<http://snohomish.wsu.edu/ag/compst.htm>).
- 2 *Mechanically agitated in-vessel composting*: compost is placed in a reactor vessel where it is mixed and aerated (http://www.frtr.gov/matrix2/section4/4_13.html). Two basic types of reactors are used in vessel composting: *vertical flow reactors* and *horizontal or inclined reactors*. In *vertical flow reactors* the mixture is fed in at the top of the reactor on either a continuous, intermittent or batch basis and can be agitated on its moving down the reactor to facilitate oxygenation. In some cases, the mixture is cycled through the reactor more than once. *Horizontal reactors* are force-aerated drums, fed continuously or intermittently with mixture. The mixture is thoroughly agitated with constant rotation of the drum. Inclined reactors are bin-structures which are continuously or intermittently fed with mixture. In most cases, both forced aeration and mechanical agitation of the mixture is simultaneously employed (http://www.esru.strath.ac.uk/EandE/Web_sites/97-8/energy_from_waste/page3.htm) (Figure 6.4a, b).
- 3 *Windrow composting*: compost is placed in long piles known as windrows and periodically mixed with means of mobile equipment (windrow turning machine) (http://www.frtr.gov/matrix2/section4/4_13.html) (Figure 6.4c). Moisture, pH, temperature and contaminant concentrations are monitored. At the completion of the composting period, the windrows are disassembled and the compost is taken to the final disposal area (<http://www.cpeo.org/techtree/ttdescript/compost.htm>). Windrow composting is usually considered to be the most cost-effective composting alternative (http://www.frtr.gov/matrix2/section4/4_13.html). These parameters are given in Figures 6.5–6.8.

Windrows are defined as regularly turned elongated piles, shaped like a haystack in cross-section and up to a hundred meters or more in length. Process control is normally through pile management as described. Static piles can be shaped much like windrows or in an elongated pile or bed. The lack of agitation requires the maintenance of adequate porosity over an extended period of time.

Horizontal reactors avoid the high temperature, oxygen and moisture gradients of vertical reactors by maintaining a short airflow pathway. Agitated systems usually use the turning process to move material through the system in a continuous mode, while static systems require a loading and unloading mechanism. Horizontal and vertical

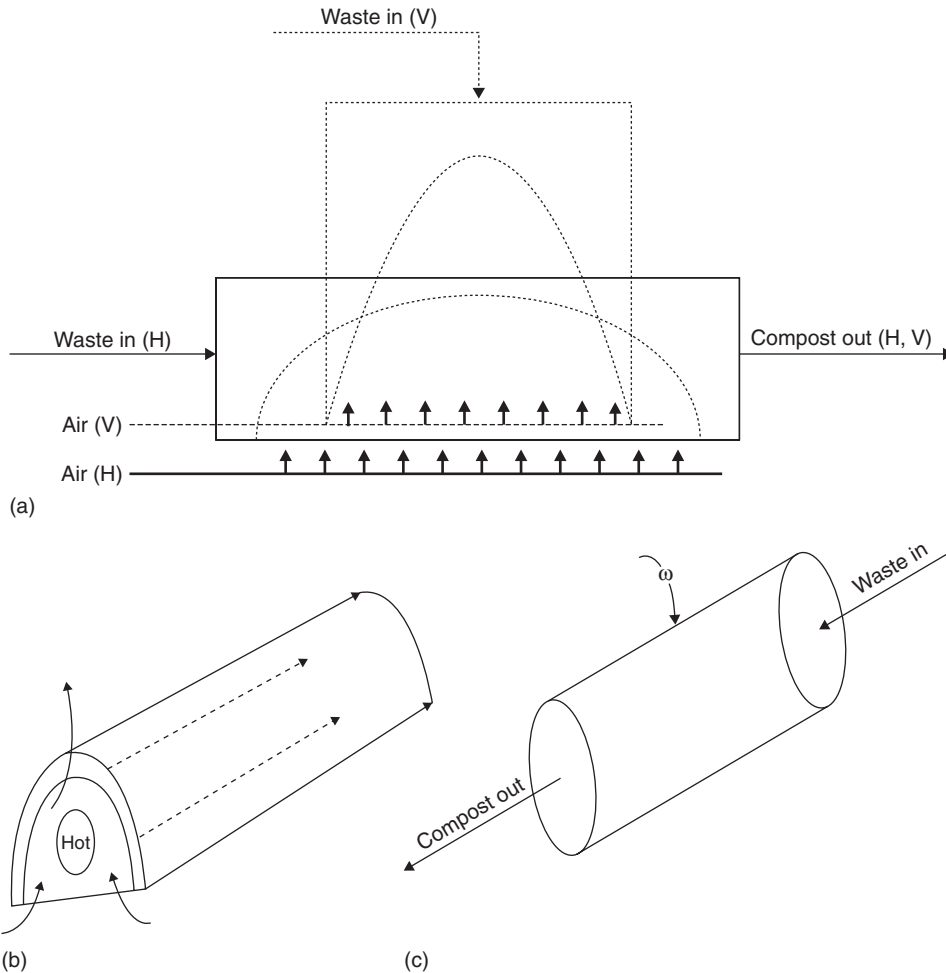

Figure 6.4 a) Composting in horizontal (H) and vertical (V) bed reactor, b) natural air circulations in typical windrow compost and c) rotating drum (adapted from Madejon *et al.*, 2001)

reactors are commonly referred to as in-vessel systems as differentiated from open systems such as windrows and static piles. Vertical composting reactors are generally over 4 meters high, and can be housed in silos or other large structures. Organic material is typically fed into the reactor at the top through a distribution mechanism, and flows by gravity to an unloading mechanism at the bottom (Richard, 1992).

Mixtures of grains with different sizes in long rotating drums exhibit both radial and axial size segregation. In case of radial segregation the grains of one type (for grains of different sizes, the smaller ones) rapidly build up a core near the axis of rotation (Aranson and Tsimring, 1999). Composting in horizontal (H) and vertical (V) bed reactor, natural air circulations in typical windrow compost and rotating drum are given in Figure 6.4a, b and c, respectively.

Composting is the aerobic biological decomposition and stabilization of organic substrates. It takes place under conditions which lead to thermophilic temperatures

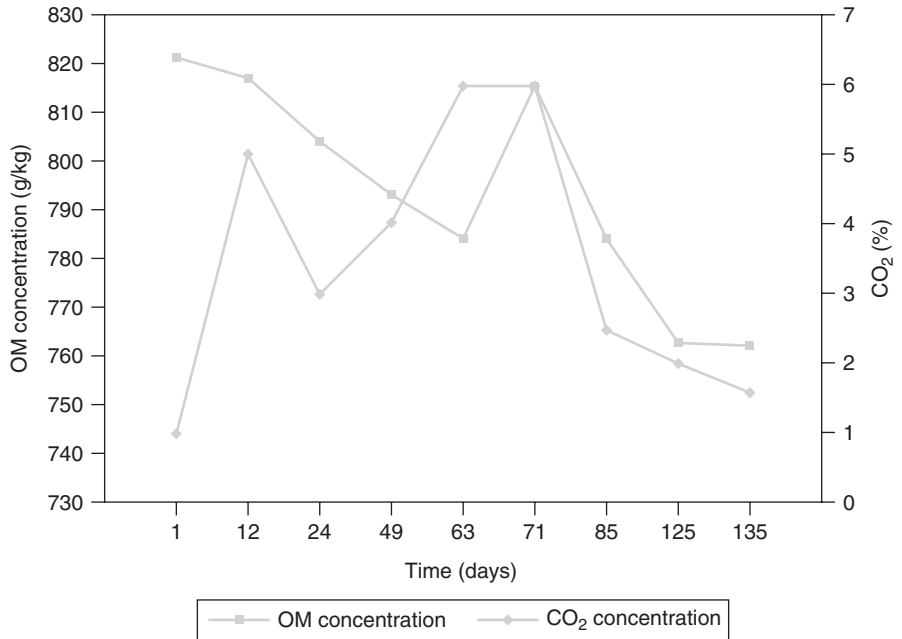

Figure 6.5 Organic matter (OM) and CO₂ concentration versus time of the composting process (adapted from Madejon *et al.*, 2002)

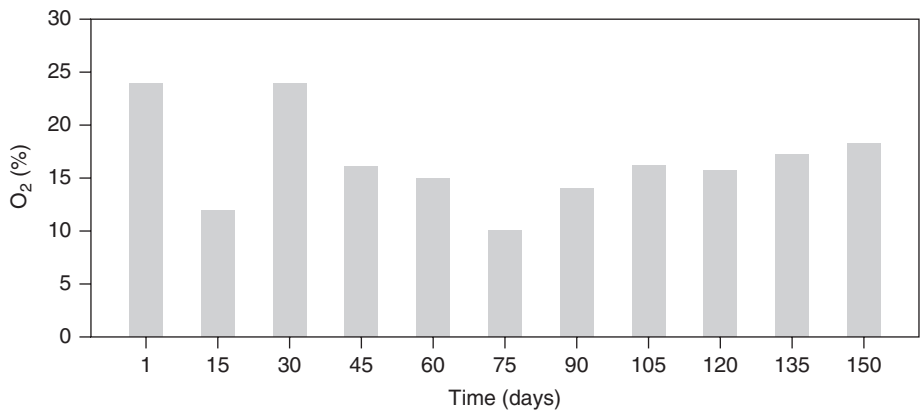

Figure 6.6 O₂ concentration versus time of the composting process (adapted from Bertran *et al.*, 2004)

due to biologically produced heat. This helps organic substrates obtain a final product that is stable, free of pathogens and plant seeds that can be beneficially applied to land (Golueke, 1982; Haug, 1993).

Composting is a method that has been used by farmers for many years because organic wastes are thereby converted into soil amendments. The latter were used to stabilize soils for erosion, provide nutrients and replenish depleted organic matter

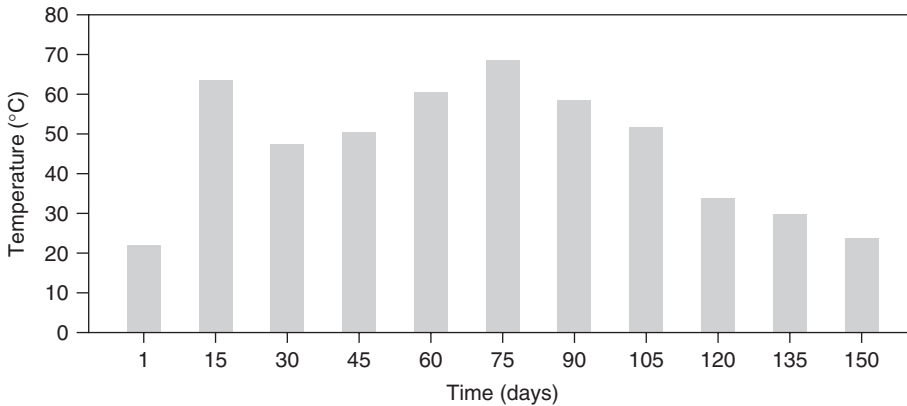

Figure 6.7 Temperature versus time of the composting process (adapted from Inbar *et al.*, 1988)

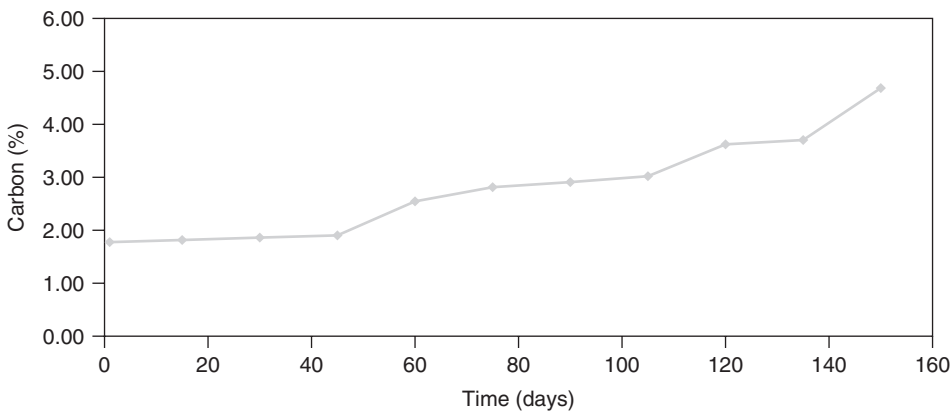

Figure 6.8 Carbon concentration against the composting process (adapted from Inbar *et al.*, 1988)

which was lost through intensive farming (Ferrer *et al.*, 2001). Composting of food waste is as an alternative to the traditional disposal of residues and also involves a commitment to reducing the production of waste materials.

During the composting process, three separate stages of activity and associated temperatures are observed: mesophilic, thermophilic and cooling. In the mesophilic stage, temperature in the compost pile increases from ambient to approximately 40°C with the appearance of fungi and acid-producing bacteria. The maximum degradation and stabilization of organic matter occurs in the thermophilic stage. The temperature in the compost pile is 40–70°C and microorganisms are replaced by thermophilic bacteria, *Actinomycetes* and thermophilic fungi. The cooling stage is characterized by a reduction in microbial activity and the replacement of thermophilic organisms with mesophilic bacteria and fungi. During the cooling period, further evaporative release

of water from the composted material occurs, as well as stabilization of pH and completion of humic acid formation (Metcalf and Eddy, 1991).

Oxygen is another important parameter for the composting method. Composting can occur under either anaerobic or aerobic conditions. Aerobic composting is not only faster but also releases no unpleasant odors. Sewage sludge of solid waste composting is generally conducted under aerobic conditions. Aerobic conditions can be obtained by periodically turning upside down the mass of organic material or by forcing air through the mass (Corbitt, 1990). Oxygen level leads to different composting conditions. Anaerobic conditions and undesirable odors occur at 0–5% oxygen levels. Appropriate oxygen levels vary between 5 and 15%. Although these levels are both economical and effective, O₂ above 15% means loss of heat, slower decomposition and poor pathogen destruction (Ferrer *et al.*, 2001).

Moisture levels for composting vary between 50 and 60%. Should moisture be above 60%, anaerobic conditions occur and below 40% decomposition is reduced. Another important parameter considerably affecting the composting process is the carbon/nitrogen ratio. The ideal ratio range is between 25 and 30%. Solid waste such as winery waste has a high ratio ranging between 35 and 80% (Corbitt, 1990).

The aerobic procedure is divided into two methods depending on the way used for the biological decomposition and stabilization of organic matter, the mechanical way in which there is an influx of forced air in the system for the composting method and secondly, the employment of agitation or turning to induce aerobic conditions. This method can function without the requirement of a bulking material except if the bulking material is used as the dried compost. The mechanical composting method is described in Figure 6.9.

At this point it is noteworthy to stress that final selection of the composting system and the design facilities depend on the following parameters.

First of all, the site (location and land availability) can considerably affect the composting method. Ideally, the composting site should be located near a landfill or in the case of sludge, adjacent to a wastewater treatment plant. Another parameter to be taken into account prior to starting the composting procedure is climate. Precipitation levels clearly affect the mixing and screening phases of the process. Low temperatures do not greatly affect the composting process unless the solid waste or sludge is frozen. Sludge characteristics are another important parameter because the percentage of solids materials, the bulking material selection and the quantities must be taken into account. Moreover, the chemical characteristics of the sludge may also affect the bulking material selection and quantity used. It must be clarified, however, that chemical characteristics mostly influence the sewage sludge. Finally, solid waste characteristics must be analyzed because the smaller the particle size, the faster and more effective the composting process is (<http://www.ees.adelaide.edu.au/pharris/biogas/pvdv.pdf>; Corbitt, 1990).

The six main methods for composting solid waste and sewage sludge are the following: windrow system, static pile, vertical system, agitated bed, plug-flow system and rotating drum. The windrow system consists of mixing the sludge with a bulking material or previously dried sludge and periodically overturning the mass. Open windrow systems are often adequate for digested sludge. When raw sludge is composted in the windrow, odor problems appear (Corbitt, 1990; Metcalf and Eddy, 1991).

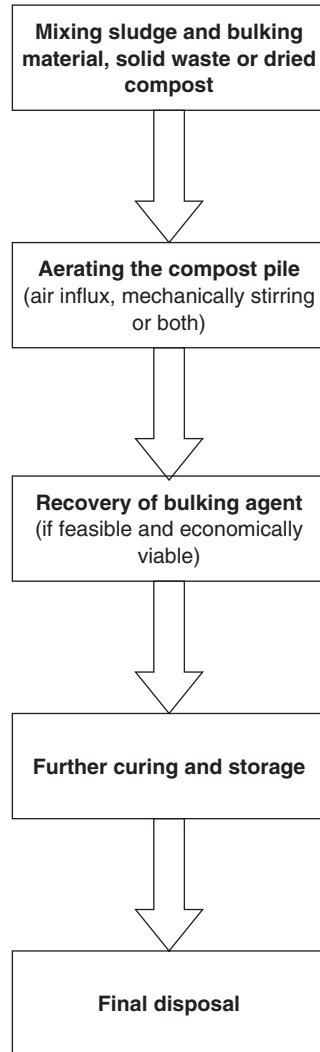

Figure 6.9 Mechanical composting method (adapted from Kulku and Yaldiz, 2004)

The second method, called static pile, consists of mixing the sludge with a bulking material and then placing the mixture over a perforated pile. Air is used to maintain proper oxygen and temperature through the airflow rate and towards greater moisture removal. After 14 to 28 days composting, the material is usually screened to recover the bulking material for re-use. During the process, if deemed necessary, the material can be transferred for a short period into a drying shed or left outdoors to cure and dry. Drying and screening before curing are preferred because they reduce the volume of material to be handled and provides a far more efficient use of the bulking material (<http://www.lagoononline.com/composting.htm>; <http://www.epa.gov/epaoswer/non-hw/composting/static.htm>; <http://www.rrc.mb.ca/environment/pdf/FeasibilityofComposting.pdf>).

Vertical systems are an effective option in enclosed systems consisting of round or square bins, silos or towers. Materials to be treated enter the top of the unit and are extracted at the bottom after having been composted for a given period of time (usually 14 days). Aerobic conditions are maintained with the circulation of forced air from the bottom of the system. Odors can be controlled either through removal or scrubbing. Temperatures or other parameters are monitored through ports along the vertical wall. Moisture control is minimal because air warms up as it progresses through the composting mixture. The heated air condenses at the top when it reaches the cool mass of new material. The composting process lasts for approximately 14 days. A typical vertical composting system is shown in Figure 6.10 (Corbitt, 1990; Metcalf and Eddy, 1991).

Agitated bed is a horizontal composting system. It consists of an aerated bed contained in a horizontal bin. Sludge introduced into the bin can periodically be turned by mechanical means and removed after 21 days. After that, curing takes place outside the bins in an open or covered area (<http://www.age.psu.edu/extension/factsheets/c/C3.pdf>; <http://www.compost.org/qna.html>).

The plug-flow system is a composting system of horizontal type and consists of a totally enclosed bin with a hydraulic ram which moves the materials through the unit. In plug-flow systems, the relationship between particles in the composting mass remains the same throughout the process and the system operates on a first-in, first-out principle (FIFO) (<http://www.vermontagriculture.com/whitepaper.pdf>; <http://www.ees.adelaide.edu.au/pharris/biogas/pvdv.pdf>).

The rotating drum is another composting system. This system consists of a large-diameter rotating drum whereby sludge and bulking materials are introduced and retained for short time periods (24–48 h). Material ejected from the drum must be further composted and then cured. These additional steps take place in the windrow or static pile (http://www.remade.org.uk/Organics/organics_documents/20001001_HBruce_CompTechSystems.pdf).

Although several of the composting process experiments were conducted with vertical systems, only two of them, one with five piles and another with four piles will be described below. Vertical systems with five piles consist of piles made from galvanized

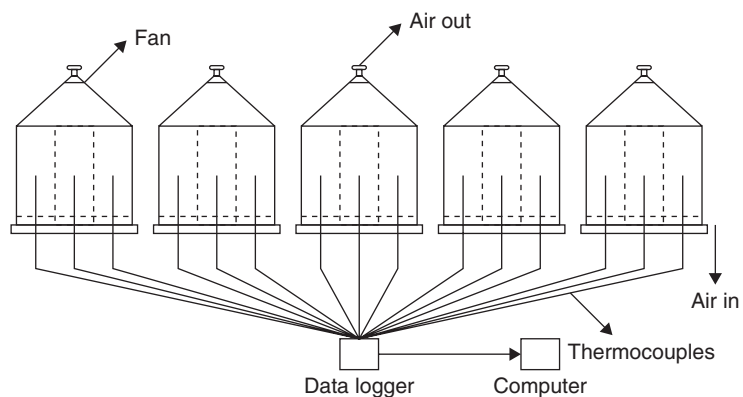

Figure 6.10 Vertical composting system consisting of five piles (adapted from Kulkul and Yaldiz, 2004)

iron sheet and insulated with glass wool (0.01 m). Its dimensions were 0.5 m in height, 0.2 m in depth and 0.6 m in width. Each of the reactors was divided into three units. The dimensions of units were 500 mm in height, 0.2 m in depth and 0.2 m in width.

These are some basic steps for the composting method with five piles:

- The heat generated is a result of microbial metabolism
- Temperature is the main factor in this study
- CO₂ is measured with a carbon dioxide analyzer at three different points of these reactors and recorded every hour between 8pm and 5am
- All composting reactors start simultaneously to avoid great variation in the ambient temperature behavior
- Organic material, pH and moisture content are measured on a daily basis.

Seven different kinetic models for modeling decomposition rate were employed in this particular approach (Haug, 1993; Ekinski *et al.*, 2001).

The vertical system with four piles are four treatments with three replicates each. Each pile contains grape compost per pile expressed in kg/ha. The amounts of compost used are 1000, 2000, 3000 and 4000 for each pile. Each hectare is equivalent to 2×10^6 kg of soil. Therefore, the compost in use for each pile per 2 kg of soil is 1, 2, 3 and 4 g, respectively.

These are some basic steps for the composting method with four piles:

- Phosphorus was adjusted to 50 kg/ha
- The high moisture content (73.6%) is adequate to guarantee standard and effective rate of oxygen consumption.
- The main mechanism of water removal in this composting process is the evaporation of water as a consequence of microbial heat generation.

Biopiles Biopiles are a hybrid of landfarming and composting (<http://www.iupac.org/publications/pac/2001/pdf/7307x1163.pdf>). Biopiles are similar to landfarms because they are both above-ground engineered systems consuming oxygen, generally from air, to stimulate the growth and reproduction of aerobic bacteria which, in turn, degrade the pollutants adsorbed to soil. While landfarms are aerated by tilling or plowing, biopiles are aerated most often by forcing air to move by injection or extraction through slotted or perforated piping placed throughout the pile (<http://www.epa.gov/swrust1/cat/biopiles.htm>). Contaminated soil is piled in heaps several meters high over an air distribution system. Aeration is provided by feeding air through the heap with a vacuum pump (high pressure). Moisture and nutrient levels are maintained at levels favoring bioremediation optimization. The soil heaps are usually placed in enclosures. Volatile contaminants are easily controlled since they are usually part of the air stream being pulled through the pile (<http://www.modflow.bossintl.com/html/exsitu-bioremediation.html>). Duration of operation and maintenance may vary considerably from a few weeks up to several months (http://www.frtr.gov/matrix2/section4/4_11.html).

***In-situ* bioremediation**

In-situ techniques do not require excavation of the contaminated soils so may be less expensive, produce less dust and cause less release of contaminants than *ex-situ* techniques. Another advantage of *in-situ* techniques is their potential to treat a large volume of soil at once. *In-situ* techniques, however, may be slower than *ex-situ* techniques, rather difficult to manage and most effective at sites with permeable (sandy or uncompacted) soil (<http://modflow.bossintl.com/html/insitu-bioremediation.html>). *In-situ* techniques include bioaugmentation, bioventing and biosparging.

Bioaugmentation This is a general term describing the addition of organisms or enzymes to a material in order to remove any undesirable chemicals. Bioaugmentation is used to remove by-products from raw materials and potential pollutants from waste. Bacteria are the most common bioaugmentation organisms. In many applications, vegetation is used to remove excess nutrients, metals and pathogenic bacteria. Wastewater from human and agricultural effluent is decontaminated by means of wetland plants (<http://www.accessexcellence.org/LC/ST/st3bg.html>).

Bioventing In the '*in-situ*' process, air is injected into contaminated soil at an optimal rate, increasing soil O₂ concentration and thereby stimulating the growth of indigenous aerobic bacteria. Low injection rates keep volatilization to a minimum. Bioventing is quite effective on organic contaminants, although concomitant use of air extraction may be required to capture volatile organic chemicals (VOCs). Bioventing tends to be most effective in the unsaturated zone (<http://www.lanl.gov/orgs/d4/enviro/etcap/overview.html>).

Biosparging Biosparging involves the injection of air under pressure below the water table to increase groundwater oxygen concentrations and enhance the rate of biological degradation of contaminants by naturally occurring bacteria. Biosparging increases the mixing in the saturated zone thereby increasing the contact between soil and groundwater. The ease and low cost of installing small-diameter air injection points allows considerable flexibility in the design and construction of the system (<http://www.iupac.org/publications/pac/2001/pdf/7307x1163.pdf>).

Thermal processes**Incineration**

On a worldwide scale, incineration is the second most widespread method of waste management after landfill (http://www.wasteonline.org.uk/resources/Wasteguide/mn_wmo_thermtreatment_incin.html).

During the process, the waste is fed into the incinerator's combustion chamber where conversion of solids and liquids into gases occurs at 870–1200°C. These gases go through the flame and are further heated, becoming so hot that the organic compounds in the gases are broken down into their constituent atoms (elemental level). These atoms react with oxygen forming stable gases that are further treated in the air

pollution control devices before being released into the atmosphere (<http://www.bizasianetwork.com/Trends%20and%20technologies%20for%20hazardous%20waste%20disposal.htm>). Incineration products are gases and solids, in the form of ash and slag. Combustion gases primarily consist of carbon dioxide and water, plus small quantities of carbon monoxide, nitrogen oxides and small concentrations of organic and inorganic compounds (<http://www.hazardouswaste.utah.gov/incin1.htm>). Another categorization of incinerators is based on their required operational time, that is short and long term.

Biomass is a renewable energy source that can be exploited by thermal conversion processes like incineration. There are several micropollutants present in the emissions of incinerators which are generated from the combustion of waste materials. Such waste is frequently employed as an energy source for domestic use or in agricultural establishments, where combustion is not optimized with regard to pollutants emission control and energy recovery. Thus, incineration is likely to be accepted due to dioxin exhaust.

The following brief presentation will be focused on the fluidized bed incineration, known for its fuel flexibility and favorable emission characteristics. Though originally developed for coal conversion, it has also been applied as a converter of other fuels, especially biomass and high-volatile organic waste. Combustor design optimization has to consider many aspects of fuels, such as gaseous emissions of nitrogen and sulfur compounds, inflammable hydrocarbons, including dioxins and heavy metals. Furthermore, the alkali content of the fuel that could contribute to agglomeration and deposits has to be equally taken into account (Leckner and Lynfelt, 2002).

A schematic diagram of the fluidized bed incinerator is shown in Figure 6.11. The fluidized bed incinerator commonly used for sludge incineration is vertical, cylindrical shaped, refractory-lined steel that contains a sand bed (media) and fluidizing air orifices to produce and sustain combustion. The fluidized bed incinerator varies in size from 2.7 to 7.6 m in diameter. In this study, the incinerator was a fluid-bed pilot plant with a furnace, a post-combustor, a gas-cooler, a lime dry acid abatement system, a fabric filter and a stack.

The mass of suspended solids and gas, when active and at operating temperature expands to double the at-rest volume. Sludge is rapidly mixed within the fluidized bed by the turbulent action of the bed. Evaporation of the water and combustion of the sludge solids take place rapidly. Combustion gases and ash leave the bed and are transported through the freeboard area to the gas outlet through the top of the incinerator. No ash exits the bed at the bottom of the incinerator (Metcalf and Eddy, 1991; Mariani *et al.*, 1992; Leckner and Lynfelt, 2002).

Circulating bed combustor A circulating bed combustor (CBC) uses high-velocity air to entrain circulating solids and create a highly turbulent combustion zone that decomposes toxic hydrocarbons. The CBC operates at much lower temperatures than conventional incinerators (725–800°C). The high turbulence of CBCs produces a uniform temperature around the combustion chamber and hot cyclone. The CBC also completely mixes the waste material during combustion. Effective mixing and low combustion temperature substantially reduce both operating costs and potential emissions of such

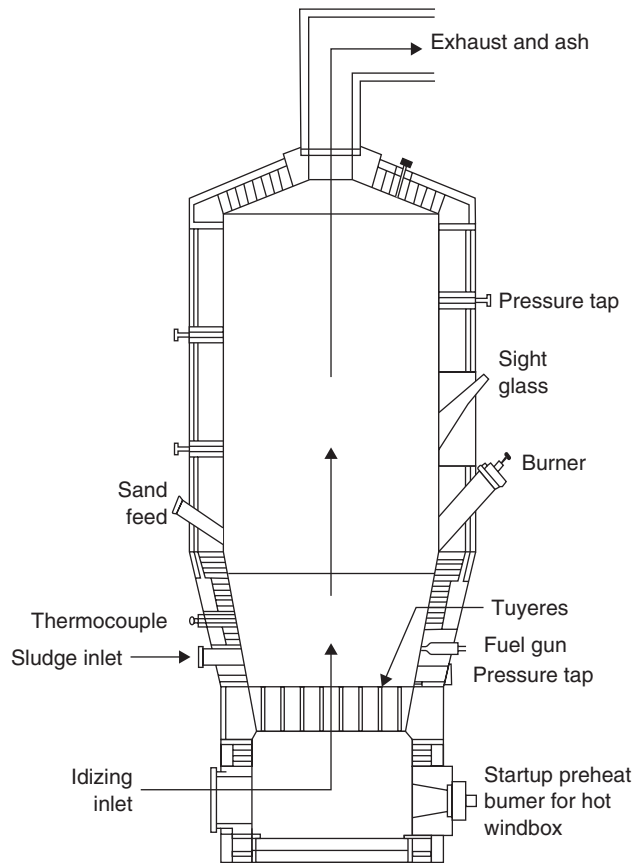

Figure 6.11 Schematic diagram of the fluidized bed incinerator (adapted from Metcalf and Eddy, 1991)

gases as nitrogen oxide (NO_x) and carbon monoxide (CO) (http://www.frtr.gov/matrix2/section4/4_26.html).

Fluidized bed Fluidized bed combustion systems use a heated bed of sand-like material suspended (fluidized) within a rising column of air to burn many types and classes of fuel. This allows oxygen to reach the combustible material much more readily and increases the rate and efficiency of the combustion process (<http://www.reslab.com.au/resfiles/waste/text.html>). The system consists of a cylindrical vertical refractory-lined vessel containing a bed of inert granular material. Air is introduced from the bottom of the column and rises vertically, fluidizing the bed at a minimum critical velocity (Perry and Green, 1984). The waste, along with the auxiliary fuel can be pumped into the bubbling bed, where combustion occurs. The heat is transferred from the bed to the waste; temperatures can vary from 725 to 800°C. Because of long retention time and intensive combustion, solid particles become light and small enough to move upward in the column. This separation allows the volatile gases to be fed to a secondary reaction chamber for further combustion. The resulting gases then pass through air pollution control equipment and are

released into the atmosphere (<http://www.nceonline.org/NLE/CRS/abstract.cfm?NLEid=15892>).

Infrared combustion The infrared combustion technology is a mobile thermal processing system that uses electrically powered silicon carbide rods to heat organic waste to combustion temperatures. Waste is fed into the primary chamber and exposed to infrared radiant heat (up to 925°C) provided by silicon carbide rods above the conveyor belt. A blower delivers air to selected locations along the belt to control the oxidation rate of the waste feed. Any remaining combustibles are further incinerated in an afterburner (<http://www.frtr.gov/matrix2/section4/4-23.html>).

Rotary kilns The rotary kiln is a horizontal cylinder, lined with a refractory surface, which turns about its longitudinal axis. Waste is deposited in the kiln at one end and the waste burns out to an ash by the time it reaches the other end. Kiln rotation speed varies in the range of 0.05–0.5 revolutions per minute. At temperatures above 1300°C, ash will start to deform and with a further temperature increase, the ash will melt. The actual temperatures of initial deformation and subsequent physical changes to the ash heavily depend on the chemical constituents present in the waste residue (http://www.nett21.gec.jp/CTT_DATA/WASTE/WASTE_3/html/Waste-095.html).

Pyrolysis

Pyrolysis transforms hazardous organic materials into gaseous components, small quantities of liquid and a solid residue (coke) containing fixed carbon and ash. Pyrolysis of organic materials produces combustible gases, including carbon monoxide, hydrogen and methane and other hydrocarbons. If the off-gases are cooled, liquids condense producing an oil/tar residue and contaminated water. Pyrolysis typically occurs under pressure and at operating temperatures above 430°C. The pyrolysis gases require further treatment. The off-gases may be further treated in a secondary combustion chamber, flared and partially condensed. Particulates removal equipment such as fabric filters or wet scrubbers is also required (http://www.frtr.gov/matrix2/section4/4_28.html).

Pyrolysis is the degradation of macromolecular materials, like biomass, heated in the absence of oxygen. Pyrolysis has been proposed as one of several technologies for disposing and recycling waste products. During pyrolysis, primary and secondary reactions occur (Meier and Faix, 1999). The pyrolysis process consists of a very complex set of reactions involving the formation of radicals (Yaman, 2004).

Biomass can be generally defined as any material with a hydrocarbon structural nature, mainly consisting of carbon, hydrogen, oxygen and nitrogen. Sulfur is also present, but of minor concentration content. Some biomass types also carry considerable proportions of inorganic species. The ash concentration produced from these inorganic materials ranges from less than 1% in softwoods up to 15% in herbaceous biomass and agricultural residues (Yaman, 2004).

Historically, biomass residues have always been used as energy sources. Thus, residues, including those originating from the wood industry, forest and agricultural workings, paper manufacturing and, more recently, specifically different vegetal species

generating energy, are renewable sources and an alternative to fossil combustibles (Hohenstein and Wright, 1994).

Pyrolysis is a thermochemical conversion route to recover energy from biomass and waste fuels. Pyrolysis is not only an independent conversion technology but also part of the gasification process, which can be broadly separated into two main stages, solid devolatilization (pyrolysis) and char conversion (combustion and gasification) (Blasi *et al.*, 1999). Pyrolysis is the simplest process among thermochemical processes, leading to carbon, tar and combustible gases as final products (Shafizadeh, 1982; Alves and Figueiredo, 1986). Depending on temperature and heating rate, there are three different types of pyrolysis: conventional, fast and flash. Conventional pyrolysis is the most appropriate way if solid phase, i.e. charcoal, is the objective (Encinar *et al.*, 1997).

The products occurring in phases resulting from biomass pyrolysis are numerous and their nature depends on the operating conditions applied. However, the final product of main interest is often the solid phase, that is vegetable carbon (charcoal). In fact, this material is widely used in the chemical, pharmaceutical and food industries not only because of its low sulfur and phosphorus content, but also because of its textural and reactivity properties. In addition, the natural porous structure of vegetable carbons can be improved by means of gasification to obtain activated carbon. These are often used both as adsorbents and supports for metal catalysts (Dacey, 1967; Mackay and Roberts, 1984). A schematic representation of the pyrolysis system is shown in Figure 6.12.

The system consists of a cylindrical stainless steel reactor supplied with a heating system, inlets for feeding the gas and accessories to collect liquid and gas samples. At

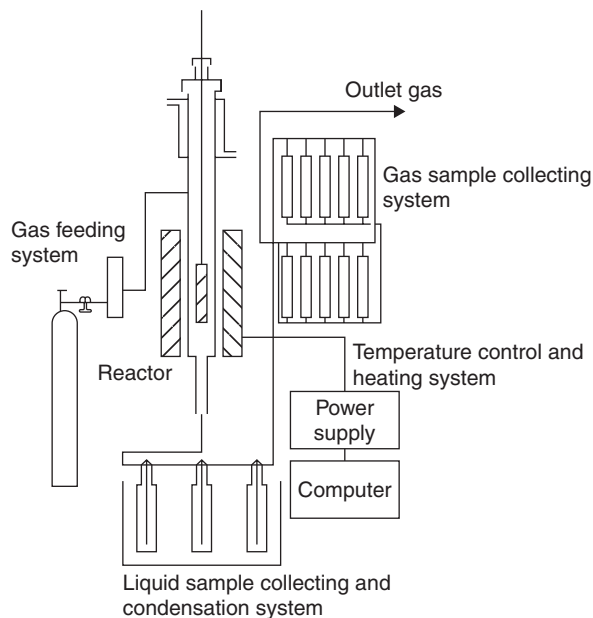

Figure 6.12 Schematic representation of the pyrolysis system (adapted from Encinar *et al.*, 1996)

its top, a heat exchanger keeps samples at ambient temperature before the start of the run and a suspension system holds the basket, containing the residue samples. The heating system is composed of a tubular ceramic furnace and power source and temperature is controlled to $\pm 5^\circ\text{C}$ automatically by means of computer software. All experiments are carried out isothermally in a fast pyrolysis regime, since waste samples are fed once the reactor reaches the reaction temperature.

The most appropriate functioning temperatures range between 600 and 700°C, at which charcoals with the highest heating value are obtained (30 MJ/kg charcoal) with satisfactory contents of fixed carbon and volatile matter. Also, at these temperatures, the liquid production is at its maximum with a high yield of gases. Temperatures higher than 600–700°C will not lead to any increase in the heating value but will incur a high consumption of energy.

Rotary kiln In this pyrolysis system, waste in the kiln is heated up to 400–500°C by the hot gas flowing on the outside. Since theoretically no oxygen is introduced into the waste, the water and volatile matter turn into pyrolysis gas, whereas fixed carbon and ash are converted into pyrolysis coke. Pyrolysis gas is burnt by mixing fresh air in the combustion chamber and an amount of the high temperature gas is introduced to the heating muffle of the kiln and is used for heating up the waste. This gas, mixed with the rest of the combustion gas, is led to a boiler for heat recovery. The steam generated by this gas is led to a steam turbine or process steam (http://www.nett21.gec.jp/JSIM_DATA/WASTE/WASTE_3/html/Doc_433.html).

Fluidized bed furnace The circulating fluidized bed uses high-velocity air to circulate and suspend the waste particles in a heating loop and operates at temperatures up to 430°C (<http://www.frtr.gov/matrix2/section4/4-25.html>). The waste is fed into this fluidized bed and instantaneously burnt efficiently. Energy is saved by recovering the waste heat from furnace exhaust gas to heat combustion air and by recovering steam. As the odorous components contained in exhaust gas are burnt and decomposed in the furnace, no deodorizing device is necessary. Since the total amount of the incinerator ash is discharged with exhaust gas, it is necessary to collect particulates effectively by using a filter dust collector, a cyclone or an electrostatic precipitator (http://www.nett21.gec.jp/JSIM_DATA/WASTE/WASTE_5/html/Doc_509_1.html).

Molten salt destruction Molten salt destruction is a relatively new technology where the waste stream and air react with molten sodium carbonate between 750 and 1000°C. The high temperature oxidizes the organic constituents of the waste, while elements such as phosphorus, arsenic and halogens react with the carbonate phase. The sodium carbonate must be periodically removed and replaced to retain the sorptive capacity (<http://www.tristate.apogee.net/et/ewtwmsd.asp>).

Gasification

The gasification products are synthetic gas (called syngas, consisting mainly of carbon monoxide and hydrogen 85%, with smaller amounts of carbon dioxide and methane), other by-products including liquids (mainly water used for washing the gas

clean) and solid residues – ash, or char (<http://www.foe.co.uk/pubsinfo/briefings/html/20021008124332.html>).

Entrained flow gasifiers Entrained flow gasification has been identified as the most efficient and environmentally-friendly technology for producing low cost electricity (together with other fuel and chemical options) from coal and other carbonaceous feedstocks (<http://www.acarp.com.au/Completed/abstracts/C9066abstract.htm>). Entrained flow gasifiers are commonly used for coal because they can be slurry fed in direct gasification mode, which makes solid fuel feeding at high pressures inexpensive (<http://www.frontlinebioenergy.com/id17.html>). In entrained flow gasifiers, the gasifying agent is supplied at high velocity so that pulverized biomass is pneumatically transported through the reactor. Oxygen is used instead of air as the gasifying agent, in order to achieve high conversion efficiency despite a low residence time in the reactor. Entrained flow gasification is only economically feasible above 200 MW thermal capacity (<http://www1.sac.ac.uk/envsci/External/WillowPower/Conversn.htm>). However, entrained flow gasifiers are generally not suitable for smaller-scale operations or coarse feedstocks such as municipal solid waste and biomass ([http://yosemite.epa.gov/r8/r8media.nsf/\(BreakingNews\)/25C1C328881A26DB87256FBA00675504](http://yosemite.epa.gov/r8/r8media.nsf/(BreakingNews)/25C1C328881A26DB87256FBA00675504)).

Fluidized bed gasifiers In a fluidized bed gasifier, the bed material can either be sand or char, or some combination. The fluidizing medium is usually air, however, oxygen and/or steam are also used. The feedstock is fed into the system either above-bed or directly into the bed, depending upon the size and density of the fuel and how it is affected by the bed velocities. When the feedstock is introduced into this environment, its drying and pyrolyzing reactions proceed rapidly, driving off all gaseous portions at relatively low temperatures. The remaining char is further oxidized within the bed to provide the required heat source for the drying and de-volatilizing reactions to continue (http://www.energyproducts.com/fluidized_bed_gasifiers.htm). Most systems are equipped with an internal cyclone in order to minimize char blow-out as much as possible. Ash particles are also carried over the top of the reactor and have to be removed from the gas stream should the gas be used in engine applications (<http://www.fao.org/docrep/X5328e/x5328e05.htm>).

Fixed bed gasifiers In a fixed bed gasifier, the feedstock is fed into the gasifier from the top and is deposited on the top of a fixed bed of material maintained in the vessel. Steam and oxygen are fed into the bottom of the unit. As the feedstock is consumed, all inorganic materials melt and are removed from the bottom of the vessel after fusion into a non-leachable, non-hazardous slag. Syngas is removed from the top of the vessel (<http://www.gtp-merichem.com/news/releases/syngas.html>).

Other thermal processes

Briquetting Briquetting can be regarded as an attempt to link up two large and complex worlds: that of agriculture and that of fuel supply and use (<http://www.fao.org/docrep/T0275E/T0275E02.htm>). Biomass briquetting involves grinding and

drying of agro wastes to produce uniform particle size and optimum moisture content. The processed agro waste is then subjected to high temperature and pressure using a screw press or mold for briquette production. The briquettes are then air cooled and properly packed to avoid direct contact with the atmosphere that might deteriorate the quality of briquettes <http://www.zenithenergy.com/BioGasfr.html>).

Activated carbon Activated carbon has the strongest physical adsorption forces or the highest volume of adsorbing porosity of any material known to mankind. Activated carbon can have a surface of greater than 1000 m²/g. This means that 5 g of activated carbon can have the surface area of a football field (http://www.edie.net/products/view_entry.asp?id=1386&channel=0). Activated carbon can be manufactured from carbonaceous material. The manufacturing process consists of two phases, carbonization and activation. The carbonization process includes drying and then heating to separate by-products, including tars and other hydrocarbons, from the raw material, as well as to drive off any generated gases. The carbonization process is completed by heating the material at 400–600°C in an oxygen-deficient atmosphere that cannot support combustion. The carbonized particles are ‘reactivated’ by exposing them to an activating agent, such as steam at high temperature. The steam burns off the decomposition products from the carbonization phase to develop a porous, three-dimensional graphite lattice structure. Longer exposure times result in larger pore sizes (http://www.aquatechnologies.com/info_activated_carbon.htm).

Evaporation

Evaporation is the vaporization of a liquid from a solution or slurry and is applicable to liquids, slurries and sludges. These materials may contain liquids and/or suspended or dissolved solids that are virtually non-volatile. After the liquid portion of the waste is evaporated, the waste volume is considerably reduced. Only the remaining residue is left for disposal as hazardous waste (<http://www.ecy.wa.gov/pubs/96414.pdf>).

Wastewater evaporators have been an industry leader in the design and manufacture of industrial wastewater evaporators since 1991 (<http://www.wastewaterevaporators.com/about-us.shtml>). A typical evaporation recovery system consists of an evaporator, a feed pump and a heat exchanger (<http://www.es.epa.gov/techinfo/facts/michigan/michfs20.html>). Wastewater evaporators concentrate aqueous waste streams by converting the water component to vapor. The clean water vapor is then released into the atmosphere, leaving only a small amount of pumpable residue for proper disposal. The evaporation process efficiently eliminated as much as 95 to 99% of the original waste and the subsequent expense and liability (<http://www.wastewaterevaporators.com/>).

Evaporators fall into two large categories: batch and continuous. Batch evaporation is usually opted for when an evaporator would run only infrequently (such as a waste stream evaporator that might only operate 8 hours a week), or when each batch needs to be uniquely identified to reduce the potential cost of a product recall (i.e. pharmaceutical industry). Continuous evaporators are used for long, commodity-like production runs, such as table salt and sugar (<http://www.tristate.apogee.net/et/extse.asp>).

Application of evaporation

The application of evaporation can be classified under the headings of vaporization, concentration and crystallization.

Vaporization In vaporization, the objective is to produce a vapor from a pure or impure liquid. The required primary product is the vapor itself or its condensate (http://www.actionenergy.org.uk/energywizard/technology_guides.asp?sectionId=TG&code=gb0069). When there is an input of extra heat to a liquid at its boiling point, at constant pressure, the molecules of the liquid acquire enough energy to overcome the intermolecular forces that bind them together in the liquid state and they escape as individual molecules of vapor until the vaporization is complete. The temperature of a boiling liquid remains constant until all of the liquid has been converted into a gas (<http://www.lenntech.com/Evaporation.htm>).

Concentration In concentration, the objective is to produce a concentrate from a dilute solution (http://www.actionenergy.org.uk/energywizard/technology_guides.asp?sectionId=TG&code=gb0069). High concentration is accomplished by boiling out a solvent, normally water, from the liquid. In most cases, concentrate resulting from the evaporation process is the final product, which may be used, for instance, for heating in another part of the process. Sometimes, however, the evaporated, volatile component is also a main product, as, for example, during solvent recovery (<http://www.niroinc.com/html/news/bg033101.html>).

Crystallization Crystallization is one of the basic operations of thermal process technology with the objective to produce a solid phase. Apart from separation, cleaning and forming of substances, crystallization is used for the recovery of inorganic (partly also organic) salts. The crystalline phase is generated from a solution or melts by means of evaporation, vacuum cooling, or cooling crystallization, depending on the particular requirements. The solid phase is separated in centrifuges, decanters, or by filtration (http://www.gea-wiegand.com/ndk_website/geawiegand/cmsdoc.nsf/WebDoc/ndkw5r9b7x).

Membrane processes

Membrane processing is a technique allowing for concentration and separation without resorting to thermal processes. Particles are separated on the basis of their molecular size and shape with the use of pressure and specially designed semi-permeable membranes (<http://www.foodsci.uoguelph.ca/dairyedu/membrane.html>).

Types of membranes

The following section explains the types of membranes commonly used.

Microporous membranes Such membranes resemble thin film that has pores passing through it. The size of these holes is related to the pore size rating of the membrane (0.01–10 μm). These membranes can be used in the separation or filtration of suspended matter from liquids and gases (http://www.pollutionengineering.com/CDA/ArticleInformation/features/BNP_Features_Item/0,6649,106432,00.html). There are three types of microporous filtration: depth, screen and surface. Depth

filters are matted fibers or materials compressed to form a matrix that retains particles by random adsorption or entrapment. Screen filters are inherently uniform structures which, like a sieve, retain all particles larger than the precisely controlled pore size on their surface. Surface filters are made from multiple layers of media. When fluid passes through the filter, particles larger than the spaces within the filter matrix are retained, accumulating primarily on the surface of the filter (<http://www.pacificro.com/Solutio2.htm>).

Homogeneous membranes Homogeneous membranes have a uniform cross-section structure, at least to a magnification of $100 \times$ (<http://www.gewater.com/pdf/TechNotes/TN%20120%20Glossary%20of%20Terms.pdf>). This structure is preferred when the material is difficult to fabricate into asymmetric or composite membranes, or when high fluxes are not important (such as for controlled release applications). In addition, homogeneous structures are preferred when the application calls for membranes with a non-directional character, such as in electrodialysis reversing (<http://www.bccresearch.com/membrane/DMD00.html>). Most homogeneous membranes were developed for microfiltration and hemodialysis (<http://www.gewater.com/pdf/TechNotes/TN%20120%20Glossary%20of%20Terms.pdf>).

Asymmetric membranes These membranes are made from asymmetric cross-sections, that is, they consist of two parallel layers. The resistance to flow of the skin layer, which imparts to membrane its filtration selectivity, is minimized by reducing its thickness. The resistance to flow of the thicker support layer, which provides structural strength, is minimized because of its open pore structure. These different layers may be fabricated from the same material, as in asymmetric cellulose acetate membranes, or from different materials, as in thin-film composite membranes (<http://www.fleckvalves.com/Carthousing.htm>).

Electrically charged membranes Electrically charged membranes can be either dense or microporous. They are most commonly very finely microporous, with the pore walls carrying fixed positively or negatively charged ions. A membrane with fixed positively charged ions is referred to as an anion-exchange membrane because it binds anions of the surrounding fluid. Similarly, a membrane containing fixed negatively charged ions is called a cation-exchange membrane. Separation with charged membranes is achieved mainly by exclusion of ions of the same charge as the fixed ions of the membrane structure and, to a much lesser extent, by the pore size (http://www.media.wiley.com/product_data/excerpt/56/04708544/0470854456.pdf).

Liquid membranes Liquid membranes have been considered a promising technology in the last decades. A liquid membrane utilizes a carrier selectively to transport components such as metal ions at relatively high rate across the membrane interface (<http://www.tifac.org.in/news/memb.htm>). Liquid membranes are highly selective and, with the use of proper carriers for the transport mechanism, specific molecular recognition can be achieved. Liquid membranes are relatively high in efficiency and, as such, are being looked into for industrial applications. However, stability is required in order to be effective and, if they are pushed out of the pores or somehow ruptured due to pressure differentials or turbulence, then they just do not function (http://separationprocesses.com/Membrane/MT_Chp07d.htm).

Membrane separation processes

Various types of membrane separation processes have been developed for specific industrial applications. Some of the most widely used processes are described below.

Reverse osmosis (RO) RO uses a semipermeable membrane which acts as a filter to retain the ions and particles on the concentrate side while allowing the water to pass through (http://www.enviro.nfesc.navy.mil/erb/erb_a/restoration/technologies/sel_tools/shortlist/shortlist.htm). Pressure is used as the driving force for the separation. The applied pressure must be in excess of the osmotic pressure of the dissolved contaminants to allow flow across the membrane (<http://www.ionics.com/technologies/ro/>). The decontaminated water passing through the membrane is called the permeate. The liquid containing the constituents that do not pass through the membrane (i.e. metals) is called the concentrate (http://www.enviro.nfesc.navy.mil/erb/erb_a/restoration/technologies/sel_tools/shortlist/shortlist.htm). RO is used to purify water and remove salts and other impurities for improving physical and sensory properties (color, taste or odor) of the fluid (http://www.gewater.com/library/tp/833_What_Is.jsp). The ability of the membrane to hold back salts while allowing water to pass is based on the fact that the salts are in ionic form when in solution, i.e. charged particles. As the charged particles, ions, approach the membrane, they are repelled by a reflection of their own charge. Therefore, the layer of water immediately adjacent to the membrane is void of charged particles and it is this water which will subsequently diffuse through the pores and be delivered as permeate. Since the anions and cations are constantly moving around in solution, sometimes they are close enough to each other to be attracted to one another, thus neutralizing their individual charges. Without a net charge, these particles are free to pass through the membrane (<http://www.wholly-water.com/reverse.osmosis/Reverse.Osmosis.htm>).

Ultrafiltration (UF) UF is a form of filtration that uses membranes preferentially to separate different fluids or ions (http://www.gewater.com/library/tp/835_Ultrafiltration.jsp). A fluid is placed under pressure on one side of a perforated membrane of a measured pore size. All materials smaller than the measured pore size pass through the membrane, leaving large contaminants concentrated on the feed side of the membrane. UF is used as a pretreatment step to RO or as a stand-alone process. The UF process cannot separate constituents from water as effectively as RO. However, the two technologies can be used in tandem, with UF removing most of the relatively large constituents of a process stream before reverse osmosis application selectively removes water from the remaining mixture. The UF process is applicable to particles in the molecular range of 0.1–0.01 μm , while the RO process is applicable for particles in the ionic range of less than 0.001 μm (http://www.p2library.nfesc.navy.mil/P2_Opportunity_Handbook/9-II-5.html).

Nanofiltration (NF) NF is another pressure driven separation process selected when RO and UF are not the ideal choice for separation (<http://www.geafiltration.com/html/technology/ftechnology.html>). The NF process occurs on a selective

separation layer formed by an organic semipermeable membrane. The driving force of the separation process is the pressure difference between the feed (retentate) and the filtrate (permeate) side at the separation layer of the membrane. However, because of its selectivity, one or several components of a dissolved mixture are retained by the membrane despite the driving force, while water and substances with a molecular weight $<200\text{ D}$ are able to permeate the semipermeable separation layer. Since, NF membranes also have a selectivity for the charge of the dissolved components, mono-valent ions will pass the membrane whereas divalent and multivalent ions will be rejected (<http://www.ameridia.com/html/nab.html>). NF can be effectively employed in separation applications not otherwise economically feasible, such as demineralization, color removal and desalination (<http://www.geofiltration.com/html/technology/technology.html>).

Microfiltration (MF) MF is a membrane separation process similar to UF but with even larger membrane pore size, allowing particles in the range of $0.2\text{--}2\ \mu\text{m}$ to pass through. The pressure used is generally lower than that of UF process (<http://www.foodsci.uoguelph.ca/dairyedu/membrane.html>). Water, salts and select macromolecules pass through a semipermeable membrane, while suspended solids are retained and progressively concentrated (http://www.acenz.com/filtration_processes/).

Electrodialysis (ED) ED is an electrochemical separation process in which mineral salts and other ionic species are transported through ion selective membranes from one solution into another under the driving force of a direct current electrical potential (<http://www.ionics.com/technologies/ed/>). The membranes are cation- or anion-selective, which basically means that either positively charged ions or negatively charged ions will flow through (<http://www.lenntech.com/electrodialysis.htm>). The electrical charges on the ions allow them to be driven through the membranes fabricated from ion exchange polymers. A voltage application between two end electrodes generates the required potential field for this. Since the membranes used in electrodialysis have the ability selectively to transport ions having positive or negative charge and reject ions of the opposite charge, useful concentration, removal or separation of electrolytes can be achieved by means of ED (<http://www.electrosynthesis.com/ess/weid.html>). Therefore, when two solutions are pumped through these respective compartments, one is demineralized by transfer of ions through the membranes, whereas the other becomes concentrated with those ions (<http://www.ionics.com/technologies/ed/>).

Electrodialysis (ED) has been used as a membrane technique to concentrate tartaric acid and malic acid from ion exchange regeneration waters obtained in grape juice treatment, in order to decrease the effluent pollution and recover their insoluble salts. Moreover, electrodialysis is also employed in reducing potassium level in vinasses (Andres *et al.*, 1997; Decloux *et al.*, 2002).

Tartaric acid is present in almost all fruits and is particularly abundant in grapes. In the classic process, tartaric acid is precipitated as calcium tartrate and isolated from the rest of the raw material compounds. Then, it is introduced into an acidic medium (sulfuric acid) and is released as tartaric acid. A subsequent concentration step is carried out by means of evaporation and finally crystallization (Smagge *et al.*, 1992).

Tartaric acid, used in the food and pharmaceutical industries, is produced only from potassium hydrogen tartrate and calcium tartrate recovered from wineries and distilleries of wine lees (Mourgues *et al.*, 1987). Two different aspects must be taken into account when these materials are to be processed. First, they are important pollutants and hence must be treated prior to disposal. Secondly, the tartaric content in such products is very low and it has been demonstrated that production of tartaric acid from these sources is only profitable provided its content is above 20% w/w in the raw material (Kirk and Otmer, 1979).

In the case of malic acid, the only type presently available is racemic acid, a synthetic by-product of maleic acid production (Smagge *et al.*, 1992). The industrial production of malic acid, L (-) malic acid, occurs through the transformation of fumaric acid into malic acid by means of *Brevibacterium flavum* (Chibata *et al.*, 1983). In addition, the use of this acid in the food industry has tripled in Europe over the last ten years, whereas the use of citric acid remained stable (Anon, 1985).

Therefore, electrodialysis is another effective way of wine waste treatment. Electrodialysis has some advantages related to the ease with which the process can be developed on an industrial scale (modular processes) and the requirement for no compound addition to the solution (Lionel and Higgs, 1966; Audinos and Paci, 1990).

A schematic representation of electrodialysis is shown in Figure 6.13. During the electrodialysis process, ionic components of a solution are separated through the use of semipermeable ion-selective membranes. The membranes used in the process are separated by spacers and assembled into stacks of wastewater. An electric current passing through the solution comes out through the electrodes. This triggers a migration of cations toward the negative and anions toward the positive electrode (Smagge *et al.*, 1992; Andres *et al.*, 1997; Concalves *et al.*, 2003).

In this case, the electrodialysis unit consisted of 10–50 cells pair sandwiched between two electrodes made of stainless steel (the cathode) and platinized titanium (the anode). The working membrane surface of the unit was between 0.5 and 2 m², and the spacers between membranes were 0.5 mm thick. The membranes used were of the SC-1 (cation exchange, $t_{\text{Na}^+} = 0.91$) and SA-1 (anion exchange, $t_{\text{Cl}^-} = 0.93$) type which present low electrical resistance and good mechanical and thermal properties. The voltage remained constant while limit current density was about 135–145 A/m² and optimal current density has been estimated at 120 A/m². The electrolyte consisted of a K₂SO₄ or a Na₂SO₄ solution (Smagge *et al.*, 1992; Andres *et al.*, 1997).

Gas separation (GS) Gas membrane separation partitions a mixture of gases into two output streams, permeate and the concentrate. When a gas mixture at high pressure encounters a membrane, physical differences cause certain components to diffuse through the membrane faster than others. To separate a gas mixture, the stream is compressed to a high pressure and permeate is forced through a porous membrane. Gas membrane separation can be used instead of distillation of a gas mixture when size constraints play an important role (http://www.facstaff.bucknell.edu/mvigeant/field_guide/pinciotti/project/gas.html).

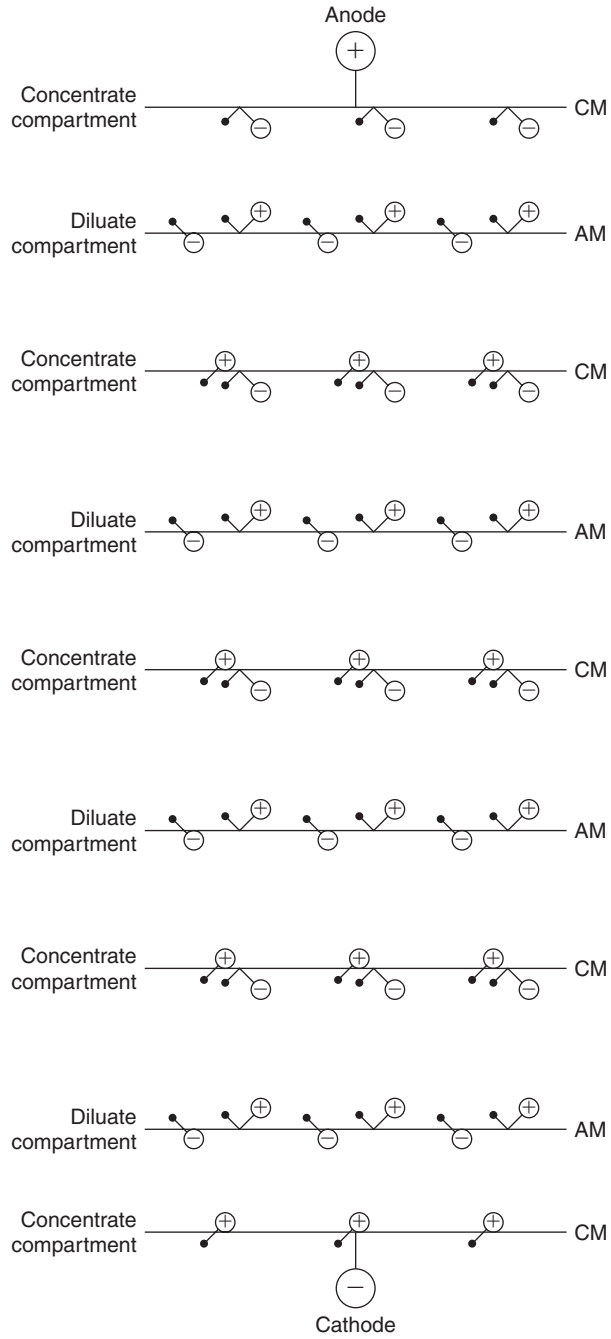

Figure 6.13 Schematic representation of electro dialysis. CM, cation exchange membrane; AM, anion exchange membrane

Pervaporation (PV) PV is another new membrane technology effectively treating small volumes of wastewater containing volatile organic compounds (Cox and Baker, 1998). PV can be considered as a specialized form of evaporation, whereby the liquid and vapor phases are separated by a non-porous membrane (<http://www.bccresearch.com/membrane/DMD00.html>). The feed is allowed to flow along one side of the membrane and a fraction of the feed (permeate) passes through the membrane and leaves in the vapor phase on the opposite side of the membrane. The ‘vapor phase’ side of the membrane is either kept under a vacuum or it is purged with a stream of inert carrier gas. The permeate is finally collected in the liquid state after condensation. The liquid product becomes enriched in the more rapidly permeating component of feed mixture, whereas the retentate is made up of the feed materials that cannot pass through the membrane (<http://www.cheresources.com/pervaporation.shtml>).

The characteristics of membranes used in different membrane separation processes, process driving forces and applications of such processes are shown in Table 6.5.

Electrolysis

When a direct electric current is passed through an electrolyte (such as a molten salt or an aqueous solution of a salt, acid or base), chemical reactions take place at the contacts between the circuit and the solution. This process is called electrolysis and takes place in an electrolytic cell (<http://www.physchem.co.za/Redox/Electrolysis.htm>). An electrolytic cell is also known as a voltameter, since it generates voltage (or current) at its two terminals (<http://www.home.att.net/~cat6a/electrolysis-I.htm>). The components coming in contact with the electrolyte are called electrodes. The electrode

Table 6.5 The characteristics of membranes used in different membrane separation processes, process driving forces and applications of such processes

Process	Membrane type and pore size	Process driving force	Applications
Microfiltration	Symmetric microporous, 0.05–10 μm	Hydrostatic pressure difference at approx. 10–500 kPa	Sterile filtration, clarification
Ultrafiltration	Asymmetric microporous, 1–50 μm	Hydrostatic pressure difference at approx. 0.1–1.0 MPa	Separation of macromolecular solutions
Reverse osmosis	Asymmetric skin-type, <1 μm	Hydrostatic pressure difference at approx. 2–10 MPa	Separation of salts and microsolute from solutions
Electrodialysis	Cation and anion exchange membrane	Electrical potential gradient	Desalting of ionic solutions
Gas separation	Asymmetric homogeneous polymer	Hydrostatic pressure and concentration gradients	Separation of gas mixtures
Pervaporation	A non-porous membrane	Vapor pressure gradient	Separation of azeotropic mixtures
Nanofiltration	Thin-film membranes, 2 nm	0.9–1.6 MPa	Removal of hardness and desalting

Adapted from <http://www.tifac.org.in/offer/tlbo/memb.htm>; <http://www.tifac.org.in/news/memb.htm>

attached to the negative pole of the battery and supplying electrons to the electrolyte is the cathode, whereas the electrode attached to the positive pole of the battery and accepting electrons from the electrolyte is the anode. Various reactions take place at the electrodes during electrolysis. In general, reduction takes place at the cathode and oxidation takes place at the anode (<http://www.physchem.co.za/Redox/Electrolysis.htm>).

Application of electrolysis

The process of electrolysis is applied in the following fields.

Electroplating of metals Electroplating is the deposition of a metallic coating onto an object (<http://www.lenntech.com/electroplating.htm>). Electroplating is achieved by passing an electric current through a solution containing dissolved metal ions and the metal object to be plated (<http://www.corrosion-doctors.org/MetalCoatings/Electroplating.htm>). The process involves an important pretreatment step in order to guarantee the quality of the plating (cleaning, removal of greases) (<http://www.lenntech.com/electroplating.htm>). The metal object serves as the cathode in an electrochemical cell, attracting metal ions from the solution. Ferrous and non-ferrous metal objects are plated with a variety of metals, including aluminum, brass, bronze, cadmium, copper, chromium, iron, lead, nickel, tin and zinc, as well as precious metals, such as gold, platinum and silver (<http://www.corrosion-doctors.org/MetalCoatings/Electroplating.htm>).

Electrorefining of metals Electrorefining is a process in which materials, usually metals, are purified by means of an electrolytic cell. The anode is the impure metal and the cathode is a very pure sample of the metal (http://www.sparknotes.com/chemistry/electrochemistry/intro/terms/term_B.3.html). An electric current is passed between a sample of the impure metal and a cathode when both are immersed in a solution containing cations of the metal. The metal is stripped off the impure components and deposited in pure form on the cathode (<http://www.unr.edu/sb204/geology/extract2.html>).

Extraction of metals or electrometallurgy In this method, the metals are processed using electricity, such as electroplating and electrorefining. Electric arc furnaces are used for steel production (<http://www.crystalinks.com/metallurgy.html>). Electrometallurgy includes the preparation of certain active metals like aluminum, calcium, barium, magnesium, potassium and sodium, by electrolysis: a fused compound of the metal, commonly the chloride, is subjected to an electric current, the metal collecting at the cathode (<http://www.unr.edu/sb204/geology/extract2.html>). Electrometallurgy is applied only when very high purity metal is required (<http://www.home.att.net/~cat6a/electrolysis-IV.htm>).

Battery All batteries one comes across nowadays are typical examples of an electrolytic cell (<http://www.chembio.uoguelph.ca/etc/waste.html>).

Ozonation

Ozone (O_3) is one of the strongest oxidizing agents that is readily available. It is used to reduce color intensity, to eliminate organic waste, to reduce odor and reduce total organic carbon in water (<http://tristate.apogee.net/et/ewtwozn.asp>). Ozone can be particularly effective for aqueous waste streams with less than 1% organic content and can be used as a pretreatment method or to disinfect wastewater after biological treatment. It is a very unstable compound and must be produced whenever needed, usually by ultraviolet excitation and corona discharge. It is not effective in treating slurries, sludges, solids, organic solvents or tars. Prior to use, one should consider the possibility that ozone is bound to oxidize other stream components that did not require treatment. Excess ozone (i.e. ozone not consumed in the reaction) must be catalytically decomposed since release is not permitted (http://www.gewater.com/library/tp/844_Ozonation_.jsp). The ozone begins to break down fairly quickly and, as it does so, it reverts back into O_2 . The bonds that hold the O atoms together are very weak, which is why ozone acts as a strong oxidant as readily as it does (<http://extoxnet.orst.edu/faqs/glossary.htm#sectO>).

Biological oxidation is generally the process of wastewater treatment plants where most of the organic load is removed. However, wastewater subjected to biological oxidation should be free of substances resistant to biodegradation or toxic to the bioculture. Therefore, sometimes, biological treatment is unable to produce an effluent complying with the current effluent-quality regulation. A possible way to overcome these problems could be the introduction of a chemical pre-oxidation step to produce biogenic intermediates or a tertiary chemical oxidative treatment (Scott and Ollis, 1995).

An alternative way for the purification of wastewater is the ozonation procedure. The latter aims at solving several problems, like the presence of phenolic compounds, already encountered in aerobic processes and linked to the high toxicity of these effluents that lead to a partial inhibition of biodegradation. Among the chemical oxidations, ozonation processes have been increasingly gaining ground (Benitez *et al.*, 1999). Furthermore, ozone is currently becoming a classic oxidizing agent for advanced treatment of wastewater (Rice, 1999). However, previous research works have also shown that ozonation may be recommended as a technology to improve wastewater treatment units, such as sedimentation or biological oxidation (Jekel, 1994; Beltran *et al.*, 1997). Thus, ozone can considerably enhance particle flocculation through different mechanisms or wastewater biodegradability by removing compounds refractory or toxic to microorganisms.

Ozone has desirable properties for water treatment because it is a powerful oxidant, soluble in water, readily available and with no by-products that need to be removed (unless ion bromide is present, since ozone reacts with this ion and produces bromo-organic derivatives and bromate) (Rice, 1981). Moreover, the additional presence of UV radiation in conjunction with hydrogen peroxide enhances the efficiency of the single ozonation, due to the generation of free radicals, like hydroxyl radicals, which are very reactive and oxidizing (Glaze *et al.*, 1987). A schematic diagram of the ozonation process is shown in Figure 6.14.

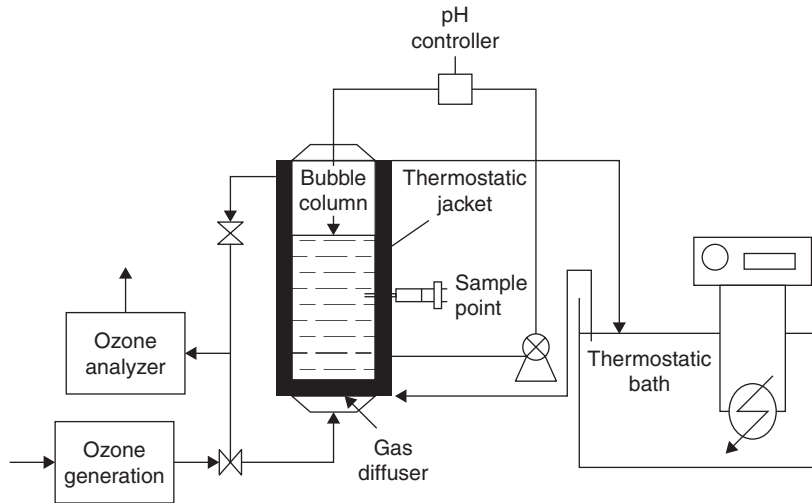

Figure 6.14 Ozone generator (adapted from Garcia-Calderon *et al.*, 1998; Mantzavinos *et al.*, 1996)

The ozonation system consisted of an ozone generator and a glass bubble column (i.d. 9 cm; length 45 cm) used as a contactor with inlets for bubbling the gas feed and stirring and outlets for sampling and venting. Ozone was produced with a GMF-Ambiozon generator from a stream of commercially available oxygen at 500 dm³/h. The stream thus obtained (a mixture of O₃ and O₂) was fed into the reactor via a Teflon pipe in order to bubble the gas (containing 34 g O₃/m³) through the wastewater. The residual gas was always bubbled through a potassium iodide (KI) solution to remove excess O₃. The reaction temperature was kept constant by means of a thermostatic reactor jacket. Wastewater samples were periodically withdrawn to analyze chemical oxygen demand (COD), total organic carbon (TOC) and dissolved ozone.

If ozone is used as a chemical oxidizing agent in wastewater treatment, the resulting degradation levels are strongly dependent on wastewater pH. This is due to the fact that pH affects the double action of ozone on the organic matter that may be a direct or an indirect (free radical) oxidation pathway (Hoigne, 1998). At low pH, ozone exclusively reacts with compounds with specific functional groups through selective reactions such as electrophilic, nucleophilic or dipolar addition reactions (i.e. direct pathway) (Langlais *et al.*, 1991). At basic pH, ozone is decomposed yielding hydroxyl radicals, a highly oxidizing species (Legrini *et al.*, 1993) which react non-selectively with a wide range of organic and inorganic compounds in water (i.e. indirect ozonation pathway).

Another possibility for degradation of food wastewater containing phenolic compounds is the advanced oxidation process consisting of combination of ozone and UV radiation. Apart from direct attacks, this reaction system is characteristic for the generation of hydroxyl radicals which increase the degradation rate (Glaze *et al.*, 1987). A set of experiments has been carried out varying the pH from 2 to 9 and maintaining a constant temperature (20°C), initial acid concentrations (100 ppm) and ozone partial pressure in the gas stream (0.43 kPa).

As a concluding remark, it can be said that ozonation may be a suitable technology to treat food wastewater. Although it is a complicated process, there are no by-products that need to be removed. Moreover, ozone is a strong oxidizing agent readily available. It is worth noting that ozonation can be combined with UV radiation or activated sludge system, thus resulting in more effective treatment of winery wastewater.

Wet oxidation

Wastewaters produced in many industrial processes, such as olive oil production or wine making, contain organic compounds, which are not amenable to conventional biological oxidation. This led to the development of several alternative oxidation processes ranging from wet oxidation, ozonation and UV irradiation to electrochemical treatment (Mantzavinos *et al.*, 1996). In spite of the high cost of oxidation processes, the use of an integrated wet air oxidation/biological treatment process, in which initially bio-recalcitrant compounds are partially oxidized to intermediates amenable to further biological oxidation, is of great interest (Mantzavinos *et al.*, 1996). Furthermore, a combination of wet air oxidation with subsequent activated sludge treatment presents high efficiency in reducing phenolic compound concentrations in wastewater (Lin and Chuang, 1994).

Wet oxidation (WO) is reported to have significant advantages over the other thermal pretreatment technologies, such as lower production of toxic sugar degradation products, significant decrease of cellulose crystallinity and high delignification potential (Schmidt and Thomsen, 1998). A major disadvantage associated with this process is the high-strength recycle liquor produced. The liquors represent a considerable organic load on the treatment system. The BOD content of the liquor may be as high as 40–50 % of that of the unprocessed sludge. Wet oxidation has been implemented in only a limited number of installations since it was launched in the early 1960s, but many of these units have subsequently been taken out of service because of corrosion, high energy costs, excessive maintenance and odor problems (Metcalf and Eddy, 1991).

The partial catalytic wet oxidation of *p*-coumaric acid, a representative compound of the biorecalcitrant phenolic fraction of wine-distillery wastewaters, has been investigated. *p*-coumaric acid (3-(4-hydroxyphenyl)-2-propenoic acid: C₉H₈O₃) was selected as representative of the biologically recalcitrant polyphenolic compounds present in wine distillery wastewaters, held responsible for major pollution problems (Mantzavinos *et al.*, 1996). It belongs to a range of compounds comprising gallic, genisteic and caffeic acids, well known to inhibit biological treatment of wastewaters of agricultural origin (Borja *et al.*, 1993). It was found that partial wet oxidation was capable of converting *p*-coumaric acid to intermediates, such as phenol and oxaloacetic acid, which are more readily biologically oxidized than the original *p*-coumaric acid (Mantzavinos *et al.*, 1996).

The catalyzed experiments performed with various homogeneous and heterogeneous catalysts showed that the use of these catalysts could increase the decomposition rate of *p*-coumaric acid compared to the uncatalyzed reaction. A typical wet oxidation system is shown in Figure 6.15. It consists of a stainless steel high-pressure reactor, which can be operating in batch or under continuous conditions.

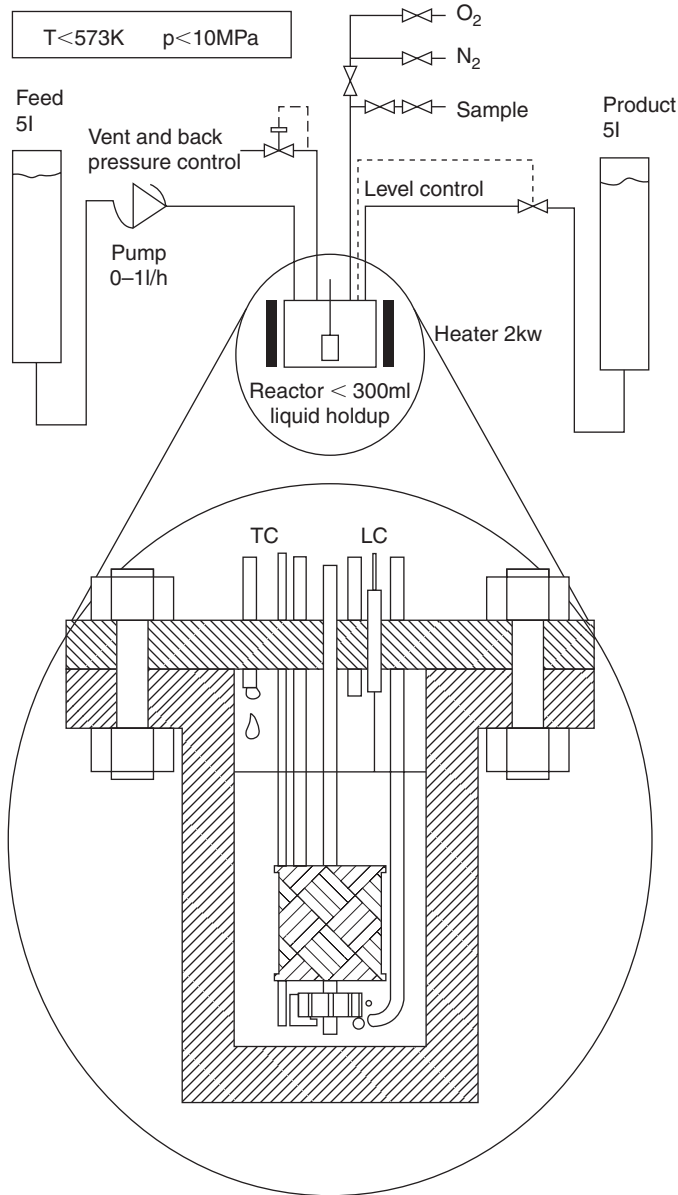

Figure 6.15 Wet oxidation system (adapted from Mantzavinos *et al.*, 1996)

Experiments were carried out at 30°C , after heating up a *p*-coumaric acid solution of initial concentration 4.5 mmol/l (maximum solubility of *p*-coumaric acid at ambient temperature) and pH 3.5 under nitrogen, while stirring at 1300–2000 rpm with a gas-inducing type impeller. Air or oxygen can be introduced into the reactor at flow rates up to 2 l/min and the liquid flow rate can be up to one l/h. In this way, oxygen was introduced continuously to the reactor, which was pressurized to keep the water in the liquid phase, at a partial pressure of 2.8 MPa to start the reaction.

As a conclusion, it can be said that the wet oxidation, with or without the support of catalysts, of *p*-coumaric acid, a representative compound of the bio-recalcitrant phenolic wine-distillery wastewaters, is an efficient method of treatment. In spite of the high cost of the process, it can be combined with other biological treatment. In fact, an integrated chemical-biological treatment, comprising wet air oxidation for conversion of *p*-coumaric acid to intermediates and further biological degradation of these intermediates seems to be a promising solution for treatment of *p*-coumaric acid-containing wastewaters.

Digestion

Anaerobic processes could either occur naturally or in a controlled environment such as a biogas plant (<http://www.ciwmb.ca.gov/Organics/Conversion/Anaerobic/>). The process of anaerobic digestion consists of three steps. The first step is the decomposition (hydrolysis) of plant or animal matter. In this step the organic material breaks down to usable-sized molecules such as sugar (<http://www.energy.ca.gov/development/biomass/anaerobic.html>). In this step, the organic waste is placed into a digester, the waste is mixed with air influx water and steam to break down the waste (http://www.mrc.wa.gov.au/resources/anaerobic_digestion.html). The second step is the conversion of decomposed matter to organic acids (<http://www.energy.ca.gov/development/biomass/anaerobic.html>). The organic waste has thus been converted into a liquid that flows into a second digester and naturally occurring microbes decompose the fatty acids to produce acetate and other simple alcohols (http://www.mrc.wa.gov.au/resources/anaerobic_digestion.html). The acids are finally turned into methane gas (<http://www.energy.ca.gov/development/biomass/anaerobic.html>). The methane gas flows towards a double membrane storage tank where it is temporarily stored. From this storage, the biogas is conveyed to the gas engines where it is converted into electricity. Some solid organic waste passes through the digestion process without being broken down into a liquid. This solid organic waste is screened to remove sand, glass and plastics and is then composted to produce a soil conditioner (http://www.mrc.wa.gov.au/resources/anaerobic_digestion.html).

Types of anaerobic digestion

Anaerobic digestion is one of the oldest processes used for sludge stabilization. It involves the decomposition of organic and inorganic matter in the absence of molecular oxygen. The major applications have been, and still remain, in the stabilization of concentrated sludge produced from the treatment of wastewater and in the treatment of some industrial wastes. More recently, it has been demonstrated that dilute organic wastes can also be treated anaerobically (Metcalf and Eddy, 1991).

Nowadays, most of the organic effluents and wastes coming from industrial, municipal or agricultural activities are effectively treated with anaerobic digestion (Naveau *et al.*, 1979). It has been experimentally demonstrated that the anaerobic digestion process is particularly well adapted to high-concentration carbon effluents, such as those coming from wine distilleries, because of the favorable characteristics of these

effluents, like their content of organic substances, relatively high temperature and good biodegradability (Sixt and Sahm, 1987; Mata-Alvarez *et al.*, 1992). In fact, due to this last peculiarity, their digestion does not require any hydrolytic pretreatment like that proposed for wastes consisting of hemicellulosic or lignocellulosic components, the exocellular hydrolysis hardly ever being the limiting step of the process (Converti *et al.*, 1997; Berardino *et al.*, 1997). This is a multistep biological process, in which organic matter is degraded into a gas mixture of methane and carbon dioxide. It thus reduces the COD of the influent and constitutes a less costly alternative from the energy point of view, because it produces a biogas containing methane, which could eventually cover a large part of the energy needs (Moletta *et al.*, 1986; Wheatley, 1990). Furthermore, the digester residues can be used in agriculture as a secondary fertilizer.

Several researchers studied the anaerobic digestion process in laboratory or pilot-scale digesters (Metcalf and Eddy, 1991). Among the several types of anaerobic digestion treatment reported in the literature for the treatment of winery wastes are AFB (anaerobic fluidized bed), the UASB (up flow anaerobic sludge-blanket), the AHF (anaerobic hybrid filter) and the up flow anaerobic fixed bed digester.

The fluidized bed (FB) bioreactor is a novel wastewater treatment process, first designed 20 years ago. Its arrival marked an important breakthrough in the biofilm process. Because of its high efficiency, stability and economy, FB has received considerable attention (Cooper and Atkinson, 1981). Interest in AFB technology has grown as it couples the recovery of usable energy with good process efficiency and stability (Perez *et al.*, 2001). The fluidized bed technology presents a series of advantages compared to the rest of anaerobic processes (Diez-Blanco *et al.*, 1995), like high organic loading rates and short hydraulic retention times. The anaerobic fluidized bed reactor utilizes small, fluidized media particles to induce extensive cell immobilization, thereby achieving a high reactor biomass holdup and a long mean cell residence time (Shieh and Hsu, 1996). A schematic diagram of the experimental set up is shown in Figure 6.16.

Among the alternative solutions proposed for anaerobic digestion, the fluidized bed reactor is certainly the most attractive but, at the same time, it is still quite complicated for full-scale industrial applications. A simpler solution is provided by the anaerobic hybrid filter that has already been successfully used for the digestion of various residues in the presence of a variety of media (Solisio *et al.*, 1987). This reactor incorporates the principles of the UASB unit and the fixed bed anaerobic filter. By simply filling the reactor with adequate inert support, the original suspended-biomass reactor can be transformed into an anaerobic hybrid filter, heated or not, where the digesting mass is mixed by the convective motion of the produced biogas and the biomass is retained in form of flocks settled at the bottom or immobilized in the medium, to ensure a sludge retention time longer than the hydraulic residence time (Berardino *et al.*, 1997). In this study, a bench-scale AHF was used for continuous digestion tests. A schematic diagram of the AHF is shown in Figure 6.17.

The original anaerobic digester to be transformed into a hybrid filter was a stirred tank reactor, functioning at 25°C. It had two sampling ports to draw samples at different heights along the column. The reactor, having an outer diameter of 110 mm, a

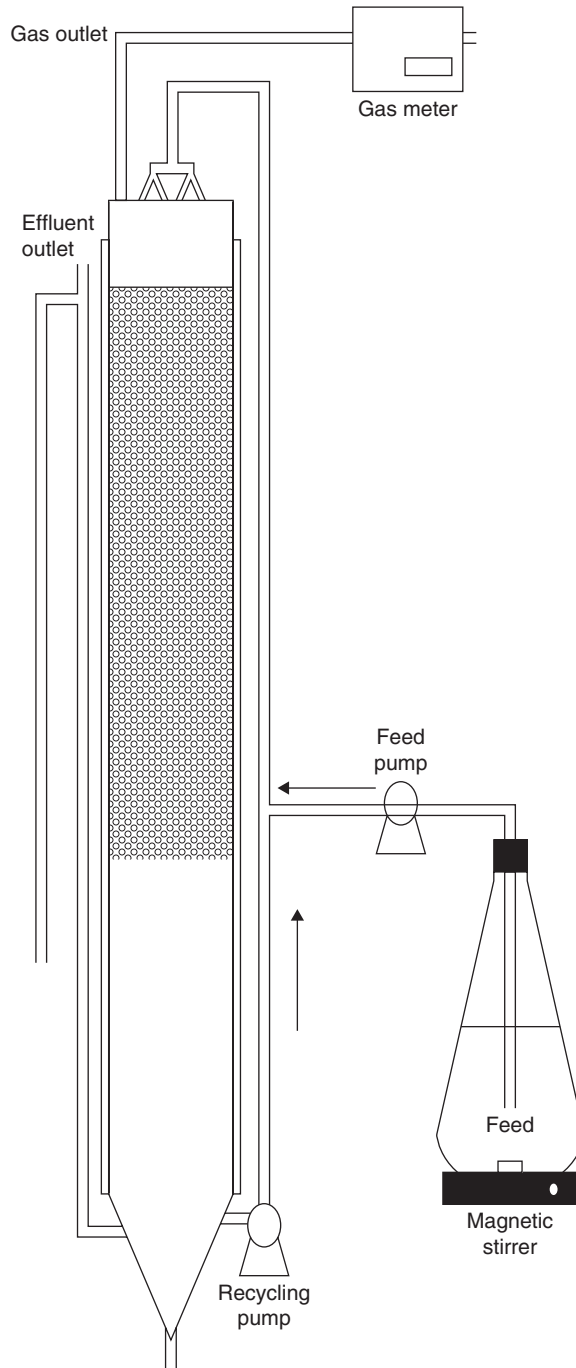

Figure 6.16 Schematic diagram of the experimental setup (adapted from Garcia-Calderon *et al.*, 1998)

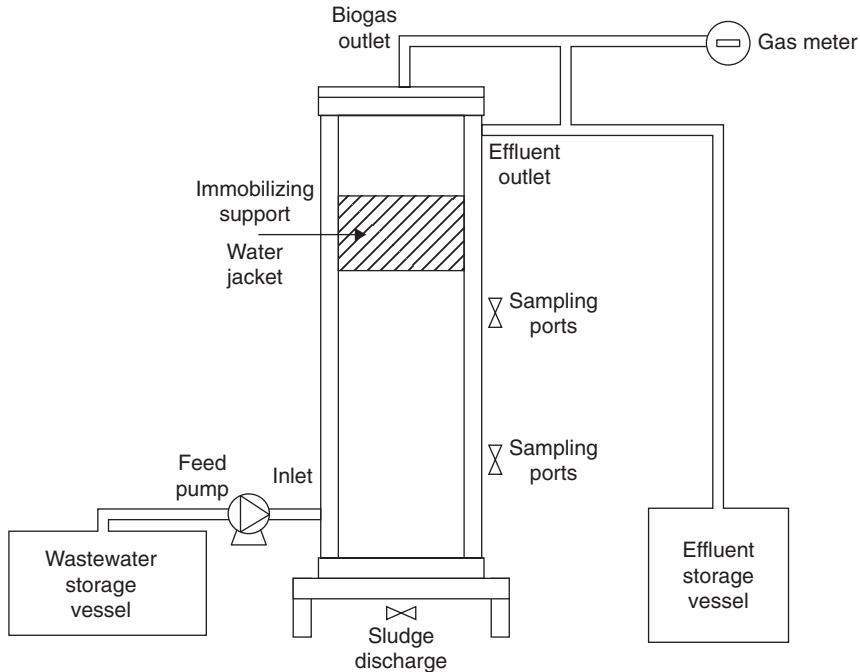

Figure 6.17 Schematic diagram of the anaerobic hybrid filter (adapted from Berardino *et al.*, 1997)

height of 1.2 m and a total volume of about 10 l, was made of transparent PVC pipes and was partially filled with a 20 cm high module of 4.5 cm long PVC pipes with 0.22 mm inner diameter. The temperature in the columns was regulated at the selected values by recirculating heated water in external jackets. The reactor was fed by means of a peristaltic pump regulated according to the selected organic load to be tested (Berardino *et al.*, 2001).

In spite of the advantages of anaerobic digestion, the anaerobic treatment units are still very rare on an industrial scale (Fripiat *et al.*, 1984). One of the main factors that contributed to this phenomenon was the lack of control schemes to guarantee the satisfactory and safe operation of the process (Mendez-Acosta *et al.*, 2004). Variations in input variables, such as influent flow rate and composition can result in the accumulation of degradation intermediates followed by a decline in process efficiency and biomass washout (Tartakovsky *et al.*, 2002). In addition, the fact that biological processes, like anaerobic digestion, depend on the activities of living organisms leads to a high complexity and often very little is known about the phenomena occurring in a bioprocess (Genovesi *et al.*, 1999). Thus, a thorough control of an anaerobic reactor was required to ensure stable operation.

Most of the anaerobic digestion plants can reach 80–90% TOC removal and 0.58–0.65 COD removal efficiency depending essentially on the applied load. In addition, the stability of the process can be improved with the application of a fuzzy logic based system, which offers an advanced control to keep the anaerobic digestion systems performance as close as possible to the optimal conditions.

In an anaerobic digestion plant, there are two types of anaerobic digestion process.

Mesophilic digestion Mesophilic digestion is the most commonly used process for anaerobic digestion, in particular waste sludge treatment (http://www.esru.strath.ac.uk/EandE/Web_sites/03-04/biomass/background%20info8.html). The digester is heated to 30–35°C and the feedstock usually remains in the digester for 15–30 days. Mesophilic digestion tends to be more tolerant than the other ‘thermophilic’ processes, but gas production is less, larger digestion tanks are required and sanitization, whenever needed, should take place in a separate process stage (<http://www.mea.org.uk/biogas/systems.htm>).

Thermophilic digestion Thermophilic digestion is less common and not as ‘mature’ a technology as mesophilic digestion (http://www.esru.strath.ac.uk/EandE/Web_sites/03-04/biomass/background%20info8.html). The digester is heated to 55°C and residence time is typically 12–14 days. Thermophilic systems result in higher methane production, faster throughput and better pathogen and virus ‘kill’, but require more expensive technology, greater energy input and a higher degree of operation and monitoring (<http://www.mea.org.uk/biogas/systems.htm>; Pearson *et al.*, 1953; Lanting *et al.*, 1989; Wohlt *et al.*, 1990).

The anaerobic fluidized bed reactor is usually employed because it couples the recovery of usable energy with high process efficiency and stability. The performance of the process is defined by the biomass retention capacity of a reactor, the substrate biodegradability and concentration and the daily flow-rate availability of the wine wastewater. The loading capacity and the subsequent biogas production rate and wastewater depollution yield are dictated by the amount of ‘active’ biomass available to grow on the biodegradable fraction. A flow diagram of the thermophilic anaerobic digestion process is shown in Figure 6.18 and a schematic diagram of the experimental reactor is shown in Figure 6.19.

Thermophilic anaerobic digestion provides an efficient solution for the treatment of winery wastes. It can reach greater than 82.5% COD removal under the applied loads. Moreover, it presents several advantages like stability, high degree of purification with high organic load feeds, low nutrient requirements and efficient biogas production with higher methane percentage and calorific value of the produced biogas than those operating in the mesophilic range (around 35°C). On the other hand, thermophilic anaerobic digestion treatment presents two major disadvantages that are worth reporting – high energy requirements for heating and super mutant containing larger quantities of dissolved solids and odors (Gallert and Winter, 1997).

A transparent Plexiglas column with a cross-section of 5.11 cm² and length of 170 cm was used. Its bottom was molded into a conical shape to promote uniform fluidization of media and bioparticles (i.e. biofilm coated media). The effluent from the fluidized bed reactor was recycled through a variable speed centrifugal pump in order to provide upflow velocities for media and to maintain 25% biparticle expansion. Recycle flow was drawn 7 cm below the free liquid surface in the enlarged section to avoid entrapment of gas accumulated in the headspace above and pumped into the bottom assembly. This stream was collected in a settler in order to separate the solid

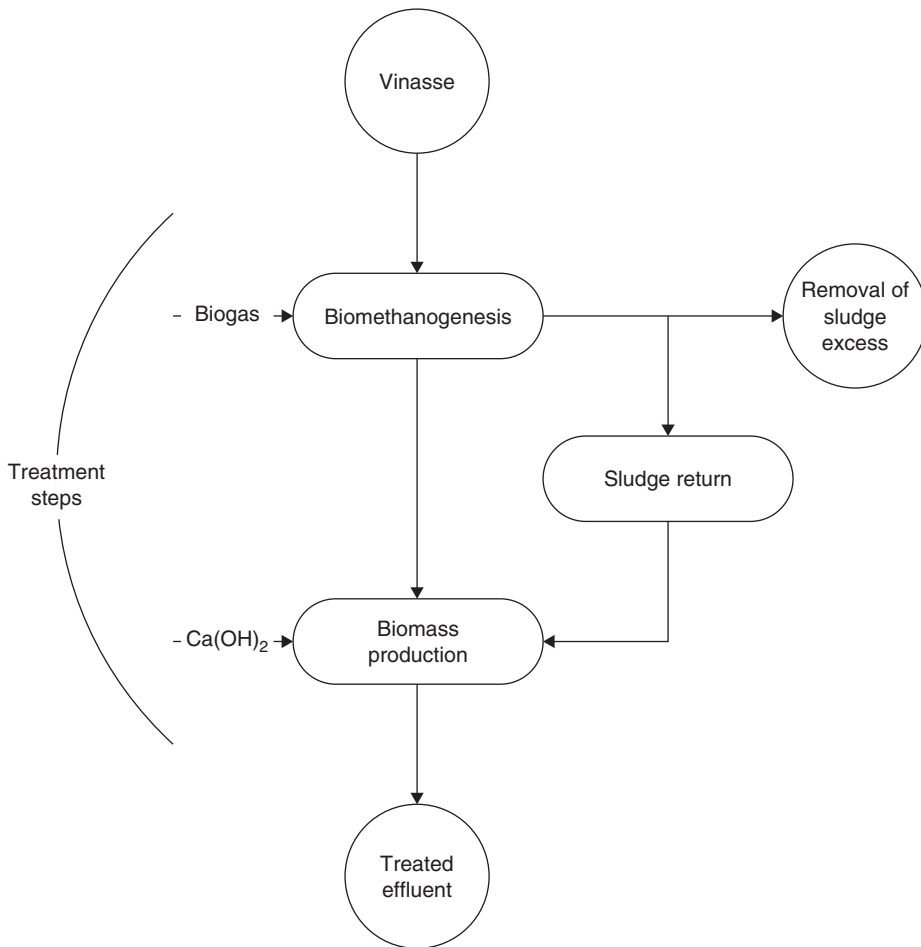

Figure 6.18 Flow diagram of the thermophilic anaerobic digestion process (adapted from Perez *et al.* 1998)

fraction from the liquid stream. In addition, gas production in the reactor is collected in a gas meter filled with an acidified saturated salt solution (Perez *et al.*, 1998, 2001).

Aerobic digestion

Biological waste treatment methods are recognized as a viable approach for the degradation of wastewater with high organic contaminant load, such as those coming from agro-industrial plants in general and from wine distilleries in particular (Benitez *et al.*, 1999). Aerobic systems, such as aerated lagoons or activated sludge units, are hence frequently used to remove the pollution generated by wastewaters from agro-industrial plants (Brenes *et al.*, 2000). The activated sludge process was developed in England in 1914 by Arden and Lockett (1914) and was so called because it involved the production of an activated mass of microorganisms capable of stabilizing a waste aerobically. Several versions of the original process are still in use nowadays, but

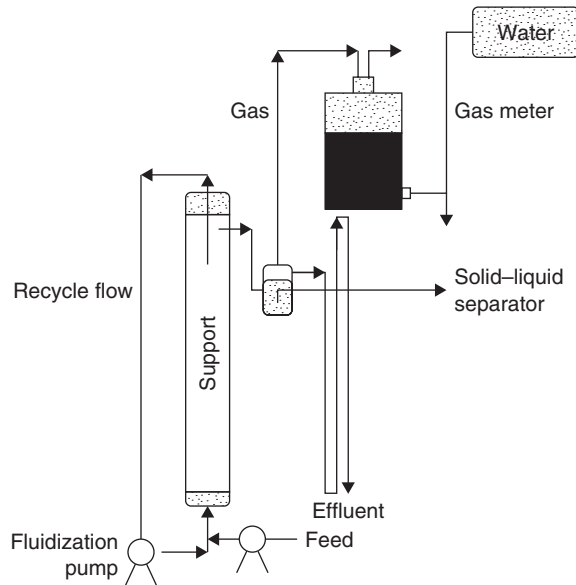

Figure 6.19 A schematic diagram of the experimental reactor (anaerobic fluidized bed) (adapted from Perez *et al.*, 1998)

fundamentally they are all similar. However, the aerobic processes have high operating costs and generate large quantities of waste sludge which require further disposal (Benitez *et al.*, 1999).

Investigation of aerobic digestion, specified as the digestion occurring in the presence of oxygen, of wine wastes by the activated sludge system revealed the following advantages compared to anaerobic digestion:

- 1 volatile solids reduction is approximately equal to that obtained anaerobically
- 2 lower BOD concentrations in supernatant liquor
- 3 production of an odorless, humus-like, biologically stable end product
- 4 recovery of more of the basic fertilizer values in the sludge
- 5 operation is relatively easy
- 6 lower capital cost (<http://www.engr.uga.edu/service/outreach/publications/biosolids/Ch03SolidsHandlingProcesses.pdf> ; Metcalf and Eddy, 1991).

The major disadvantages of the aerobic digestion process are as follows:

- 1 a high power cost is associated with supplying the required oxygen
- 2 a digested sludge is produced with poor mechanical dewatering characteristics
- 3 the process is affected significantly by temperature, location and type of tank material.

An additional disadvantage is that a useful by-product such as methane is not recovered. In cases where separate sludge digestion is considered, aerobic digestion of biological sludge may be an attractive application (Metcalf and Eddy, 1991; Vlissidis and

Zouboulis, 1993; <http://www.engr.uga.edu/service/outreach/publications/biosolids/Ch03SolidsHandlingProcesses.pdf>).

The aerobic digestion process was often conducted by means of an activated system, comprising an aeration reactor and a clarifier in two studies by Benitez *et al.* (1999, 2003). The reactor was submerged in a thermostatic bath for maintaining the temperature constant at 25–28°C. The airflow was fed to the reacting medium at a constant flow rate of 40 l/h at room temperature.

Types of digester designs

The type of digester to be used greatly depends upon the waste type availability and the waste collection method. There are essentially three types of digester designs.

Covered lagoon Covered lagoon digesters are the simplest anaerobic digester system. These systems typically consist of an anaerobic combined storage and treatment lagoon, an anaerobic lagoon cover, an evaporation pond for the digester effluent and a gas treatment and/or energy conversion system. A collection pipe starting from the digester carries the biogas to either a gas treatment system such as a combustion flare, or to an engine/generator or boiler that uses the biogas to produce electricity and heat. Following treatment, the digester effluent is often transferred to an evaporation pond or to a storage lagoon prior to land application. Covered lagoon digesters are most appropriate for use in warm climates if the biogas is to be employed for energy or heating purposes (http://www.cogeneration.net/anaerobic_lagoons.htm).

Complete mix digesters The complete mix digester is a large, vertical poured concrete or steel circular container. Nowadays, complete mix digester can treat organic wastes with total solid concentration of 3 to 10%. Complete mix digesters can be operated at either the mesophilic or thermophilic temperature (http://www.energy.ca.gov/pier/renewable/biomass/anaerobic_digestion/).

Plug flow digesters Plug flow digesters are normally used where wastes are collected as solids (solids greater than 11%). Plug flow digesters are large tanks (often built into the ground) with an impermeable plastic cover. Although the contents are usually heated, they are not mixed because they move through the digester as a combined mass or a 'plug'. Plug flow digesters have been used mostly with scraped dairy wastes, but a few were also applied to swine wastes (<http://www.nfec.org/digester.htm>).

Coagulation/flocculation/precipitation

Coagulation or destabilization of a colloidal suspension results in joining of minute particles by physical and chemical processes. Flocculation results in formation of a larger settleable structure by bridging. These processes have been commonly used to remove suspended matter or color. Adsorption of ionic forms also occurs to varying extent depending mainly on the constituents in the water or wastewater (<http://www.ec.njit.edu/~hsieh/ene670/coagula.html>).

In the precipitation process there is usually adjustment of pH, addition of chemicals to stimulate precipitation, addition of coagulants and mixing of fluid in a device called a flocculator. The chemical precipitants, coagulants and flocculator are all used to increase particle size through aggregation. Commonly used precipitants include carbonates, sulfates, sulfides, lime and other hydroxides. The precipitants generate very fine particles that remain in suspension. Coagulants are often added to aggregate the suspended particles. Mixing in a flocculator following the addition of coagulants promotes contact between the particles which, in turn, promotes particle growth and settling. In anaerobic environments, bacteria react with soluble metals to form insoluble metal precipitants (<http://www.cpeo.org/techtree/ttdescript/precip.htm>). The most widely used chemical precipitation process is hydroxide precipitation (also referred to as precipitation by pH), in which metal hydroxides are formed by using calcium hydroxide (lime) or sodium hydroxide (caustic) as the precipitant. Each dissolved metal has a distinct pH value at which the optimum hydroxide precipitation occurs. Metal hydroxides are increasingly soluble at both low and high pH values. Therefore, the optimum pH for precipitation of one metal may cause another metal to solubilize, or start to go back into solution (http://www.waterspecialists.biz/html/about_chemical_precipitation.html).

Coagulation can be carried out both with chemical or electrical means. Chemical coagulation is becoming less acceptable nowadays because of the higher costs associated with chemical treatments (e.g. the large volumes of sludge generated and the hazardous waste categorization of metal hydroxides, not taking into account the costs of the chemicals required to effect coagulation) (<http://www.powellwater.com/ec-overview.htm>). Coagulants and flocculants are chemicals used to precipitate insoluble substances. The main types of coagulants used are electrolytes, organic polymers and synthetic polyelectrolytes (<http://www.earthpace.com/resources/wwt/coagulation.html>).

The coagulation processes generally employ several steps. First, the coagulant is added to the effluent and mixing proceeds rapidly and with high intensity. The objective is to obtain thorough mixing of the coagulant with the wastewater thus increasing the effectiveness of destabilization of particles and initiating coagulation. A second stage follows in which flocculation occurs for periods of up to 30 minutes. In this stage, the suspension is slowly stirred to increase the contact between coagulating particles and to facilitate the development of large flocs. These flocs are then transferred to a clarification basin where they settle and are removed from the bottom while the clarified effluent overflows (<http://www.fao.org/DOCREP/003/V9922E/V9922E06.htm>).

Distillation

Distillation is the process of heating a liquid until it boils, capturing and cooling the resultant hot vapors and collecting the condensed vapors (<http://www.orgchem.colorado.edu/hndbksupport/dist/dist.html>). The objective of distillation is to separate the components of a homogeneous mixture of liquid phases (http://www.actionenergy.org.uk/energywizard/technology_guides.asp?sectionId=TG&code=gb0070). The liquid can be heated to force components of different boiling points into the gas phase.

The gas is then condensed back into liquid form and collected. Repeating the process on the collected liquid one can improve the purity of the product and this is called double distillation. Types of distillation include simple distillation (described here), fractional distillation (different volatile 'fractions' are collected as they are produced) and destructive distillation (usually, a material is heated so that it decomposes into compounds for collection) (<http://www.chemistry.about.com/cs/5/f/bldistillation.htm>).

The principles of solar distillation have been around for centuries. In the fourth century BC, Aristotle suggested a method of evaporating seawater to produce potable water. However, the first solar still was not produced until 1874, when Harding and Wilson built a still in Chile to provide fresh water to a nitrate mining community (<http://www.energy.saving.nu/solarenergy/collectors.shtml>). The basic principles of solar water distillation are simple yet effective, as distillation practically replicates the way nature makes rain (<http://www.solaqua.com/solstilbas.html#ssback>).

Other methods

Ultrasound irradiation

In recent years, ultrasound irradiation has gained ground for the destruction of organic pollutants in waters and wastewaters. Sonochemical degradation in aqueous phase involves several reaction pathways and zones such as pyrolysis inside the bubble and/or at the bubble–liquid interface and hydroxyl radical-mediated reactions at the bubble–liquid interface and/or in the liquid bulk (Thompson and Doraiswamy, 1999).

Sequencing batch reactor

A sequencing batch reactor (SBR) is a fill-and-draw activated sludge system. The unit processes involved in the SBR and conventional activated sludge systems are identical. Although aeration and sedimentation/clarification are carried out in both systems, there is one important difference; in conventional plants, the processes are carried out simultaneously in separate tanks, whereas in SBR operation the processes are carried out sequentially in the same tank (Metcalf and Eddy, 1991).

Research on SBR reactors began in the 1970s, simultaneously with the development of other discontinuous processes. Even in 1914, the reactors based on active biomass designed by Arden and Lockett were operated according to the principles of SBR technology (Mace and Mata-Alvarez, 2002).

This technology has been gaining popularity through the years, because of the following benefits and advantages:

- 1 lower cost than conventional biological treatment
- 2 less land requirements than those by conventional methods
- 3 capable of handling wide swings in hydraulic and organic loadings
- 4 easier to control filamentous growth and settling problems
- 5 less equipment to maintain
- 6 less operator attention

- 7 greater operator flexibility
- 8 biomass cannot be washed out
- 9 bad settling can be recognized and corrected
- 10 powdered activated carbon can be added.

All SBR systems have five steps in common carried out in the following sequence: fill, react (aeration), settle (sedimentation/clarification), draw (decant), idle. The use of SBR technology to treat the wine waste was investigated.

Although the depollution of winery wastewater by sequencing batch reactor can be very effective (elimination of organic matter: total COD 93–97%, soluble COD 95% and 97.5% BOD₅ removal), it is worth reporting its disadvantages:

- 1 a higher level of sophistication is required (compared to conventional systems), especially for larger systems, of timing units and controls
- 2 potential of discharging floating or settled sludge during the draw or decant phase with some SBR configurations
- 3 potential requirements for equalization after the SBR, depending on the downstream processes.

Solid-state fermentation

Solid-state fermentation (SSF) is defined as any fermentation process occurring in the absence or near absence of free liquid, employing an inert substrate or a natural substrate as a solid support (Pandey *et al.*, 1999).

In recent years, there has been an increasing trend towards efficient utilization and value-addition of agro-industrial waste in solid-state cultivation. The utilization of these wastes in bioprocesses not only provides alternative substrates, but also helps in solving pollution problems. Various agricultural substrates, by-products and white rot fungi have been used successfully in solid-state fermentation for ligninolytic enzyme production (Rodriguez-Couto *et al.*, 2002).

Lignin, a main contributor of the total carbon of agro-industrial wastes, produces polycyclic aromatic hydrocarbon components such as benzopyrene, catechol, hydroquinone phenanthrene and naphthalene when thermally degraded (Kjallstrand *et al.*, 1998). All of these compounds can inhibit DNA synthesis and induce cancerous tumors in liver, lung, larynx and cervix in animals and humans (Tsutsui *et al.*, 1997).

Among the several microorganisms used in the solid-state fermentation of wine wastes some of the most important are *Phanerochaete chrysosporium*, *Trametes hirsuta*, *Lactobacillus* spp., *Pleurotus* spp. and *Aerobasidium pullulans*. *Pleurotus ostreatus-complex* is the third most important edible mushroom cultivated worldwide (Royse, 1997). It can efficiently decompose lignocellulose without chemical or biological pretreatment because it possesses an enzymatic complex system that includes phenol oxidases and peroxidases (Leonowicz *et al.*, 1999). *Pleurotus ostreatus-complex* was also often predominant in a wood decay complex on grapevines in northern California (Vail *et al.*, 1995).

Moreover, the basidiomycete *Phanerochaete chrysosporium* has become the most commonly used model organism in lignin biodegradation studies due to its good ligninolytic properties, fast growth and easy handling in culture (Kirk and Farrell, 1987). Two families of extracellular hemoperoxidases, secreted by *Phanerochaete chrysosporium* during its secondary metabolism in response to nutrient limitation, namely lignin peroxidase (LiP) and manganese-dependent peroxidase (MnP), are responsible for the degradation (Rodríguez-Couto *et al.*, 2003).

Along with other microorganisms, *Aerobasidium pullulans* has been used in environmental pollution control. It has been employed for treating different industrial wastes, such as orange peel, apricot canning wastes, olive mill wastes and molasses. *Aerobasidium pullulans* was also actively involved in the degradation of organochlorine compounds in bleaching effluents of kraft pulping. Moreover, phenol-bearing industrial wastes have been reported to be effectively cleaned up by strains of *Aerobasidium pullulans* (Arapoglou *et al.*, 2002).

The microorganisms in solid-state cultures grow under conditions close to their natural habitats, as a result they may be more capable of producing certain enzymes and metabolites, which usually will not be produced or will be produced only at low yield in submerged cultures (Pandey *et al.*, 1999). The selection of an adequate support for performing solid-state cultivation is essential, since the success of the process depends on it. The most important factors to take into account are particle size, porosity and chemical composition. In addition to this, availability and cost are also criteria of great importance.

The whole process could be summarized as follows: first, the microorganisms are grown on a basal medium containing per liter: 4–20 g/l glucose as a carbon source, 5–15 g yeast extract, 0.75 g NH₄Cl, 2 g KH₂PO₄, 0.5–0.6 g SO₄ · 7H₂O, 0.1 g CaCl₂ · 2H₂O, 0.5 g KCl and 20 mM acetate buffer (pH 4.5). The fungus was grown in this medium at 30–37°C in complete darkness for 12 to 48 hours. Afterwards, the culture broth was homogenized for 1 min and sterilized at 12°C for 20 min (Sanchez *et al.*, 2002; Rodríguez-Couto *et al.*, 2003; Bustos *et al.*, 2004).

The support, food waste, was stored at 4°C and autoclaved at 120°C for 20 min until used. Then, inoculation was carried out directly in cotton-plugged Erlenmeyer flasks (250 ml). The Erlenmeyer flasks were loosely capped with cellulose stoppers, allowing a passive aeration, and incubated statically under an air atmosphere at 28–37°C and 80–90% humidity, to avoid evaporation, in complete darkness (Sanchez *et al.*, 2002; Rodríguez-Couto *et al.*, 2003; Bustos *et al.*, 2004).

The decolorization of type model dyes is a simple method to assess the aromatic degrading capability of ligninolytic enzymes (Novotny *et al.*, 2001). The ability to decolorize the polymeric dyes by ligninolytic fungi is correlated with their ability to degrade several lignin model compounds (Chet *et al.*, 1985). Therefore, the assay with dyes is a simple and reliable method to assess the degradative ability of the ligninolytic complex secreted by such fungi. The *in vitro* decolorization of Poly R-478 0.03% (w/v), Indigo Carmine 60 µM, Phenol Red 50 µM, Methyl Orange 50 µM and Bromophenol Blues 40 µM dyes by the extracellular fluid secreted by winery wastes cultures of *Phanerochaete chrysosporium* and *Trametes hirsuta* was effectively carried out (Rodríguez-Couto *et al.*, 2003; Moldes *et al.*, 2003).

References

Scientific references

- Alves, S. and Figueiredo, J. (1986). Fuel gas from a wood waste carbonization reactor. *Fuel* **65**, 1709.
- Andres, L., Riera, F. and Alvarez, R. (1997). Recovery and concentration by electro dialysis of tartaric acid from fruit juice industries waste waters. *J Chem Technol Biotechnol* **70**, 247–252.
- Anon. (1985). Malic acid: a bitter story. *Food Process* **54**, 31–33.
- Aranson, I. and Tsimring, L.S. (1999). Dynamics of axial separation in long rotating drums. *Phys Rev Lett* **82**, 4643.
- Arapoglou, D., Israilides, C.J., Bocari, M., Scanlon, B. and Smith, A. (2002). In *Proceedings of the International Conference. Protection and Restoration of the Environment VI*, pp. 469. Skiathos, Greece.
- Ardern, E. and Lockett, W.T. (1914). Experiments on the oxidation of sewage without the aid of filters. *J Soc Chem Ind* **33**, 1112.
- Arvanitoyannis, I.S., Ladas, D. and Mavromatis, A. (2006a). Potential uses and applications of treated wine waste: a review. *Int J Food Sci Technol* **41**, 475–487.
- Arvanitoyannis, I.S., Ladas, D. and Mavromatis, A. (2006b). Wine waste treatment methodology. *Int J Food Sci Technol* **41**, 1117–1151.
- Aubrun, C., Harmand, J., Garnier, O. and Steyer J-Ph. (2000). Fault detection filter design for an anaerobic digestion process. *Bioprocess Engin* **22**, 413–420.
- Audinos, R. and Paci, S. (1990). Direct production of pure concentrated tartaric acid from tartaric wastes by electromembrane processes. *5th Mediterranean Congress on Chemical Engineering*, Barcelona, Spain.
- Beltran, F., Garcia-Araya, J. and Alvarez, P. (1997). Impact of chemical oxidation on biological treatment of a primary municipal wastewater. 1. Effects on COD and biodegradability. *Ozone Sci Engin* **35**, 929–936.
- Beltran, F., Alvarez, P., Rodriguez, E., Garcia-Araya, J. and Rivas, J. (2001). Treatment of high strength distillery wastewater (cherry stillage) by integrated aerobic biological oxidation and ozonation. *Biotechnol Prog* **17**, 462–467.
- Beltran, F., Garcia-Araya, J. and Alvarez, P. (2001). pH sequential ozonation of domestic and wine-distillery wastewaters. *Water Res* **35**, 929–936.
- Benitez, F., Beltran-Heredia, J., Acero, J. and Pinilla, M. (1997). Simultaneous photodegradation and ozonation plus UV radiation of phenolic acids, major pollutants in agro-industrial wastewaters. *J Chem Technol Biotechnol* **70**, 253–260.
- Benitez, F., Beltran-Heredia, J., Real, F. and Acero, J. (1999). Enhancement of the ozonation of wine distillery wastewaters by an aerobic pretreatment. *Bioprocess Engin* **21**, 459–464.
- Benitez, F., Beltran-Heredia, J., Real, F., Acero, J. and Gonzalez, T. (1999). Aerobic and anaerobic purification of wine distillery wastewater in batch reactors. *Chem Engin Technol* **22**, 165–172.
- Benitez, F., Real, F., Acero, J., Garcia, J. and Sanchez, M. (2003). Kinetics of the ozonation and aerobic biodegradation of wine vinasses in discontinuous and continuous processes. *J Hazard Mat* **101**, 203–218.

- Berardino, S., Bersi, R., Converti, A. and Rovatti, M. (1997). Starting-up an anaerobic hybrid filter for the fermentation of wastewater from food industry. *Bioprocess Engin* **16**, 65–70.
- Berardino, S., Caetano, L. and Converti, A. (2001). Characterization and anaerobic pre-treatment of the effluent from a wine cooperative. *Engin Life Sci* **3**, 127–131.
- Bernard, O., Hadj-Sadok, Z., Dochain, D., Genovesi, A. and Steyer, J.-P. (2001). Dynamical model development and parameter identification for an anaerobic wastewater treatment process. *Biotechnol Bioengin* **75**, 424–438.
- Bertran, E., Sort X., Soliva, M. and Trillas, I. (2004). Composting winery waste: sludges and grape stalks. *Bioresource Technol* **95**, 203–208.
- Blasi, C., Signorelli, G., Russo, C. and Rea, G. (1999). Product distribution from pyrolysis of wood and agricultural residues. *Indust Engin Chem Res* **38**, 2216–2224.
- Borja, R., Martin, A., Maestro, R., Luque, M. and Duran, M.M. (1993). Enhancement of the anaerobic digestion of wine distillery wastewater by the removal of phenolic inhibitors. *Bioresource Technol* **45**, 99–104.
- Brenes, M., Garcia, P., Romero, C. and Garrido, A. (2000). Treatment of green table olive waste waters by an activated-sludge process. *J Chem Technol Biotechnol* **75**, 459–463.
- Bridgwater, A.V. and Bridge, S.A. (1991). *Biomass pyrolysis liquids, upgrading and utilization*. Elsevier Applied Science, London.
- Bustos, G., Moldes, A., Cruz, J. and Dominguez, J. (2004). Evaluation of vinification lees as a general medium for lactobacillus strains. *J Agric Food Chem* **52**, 5233–5239.
- Bustos, G., Moldes, A., Cruz, J. and Dominguez, J. (2004). Formulation of low-cost fermentative media for lactic acid production with *Lactobacillus rhamnosus* using vinification lees as nutrients. *J Agricult Food Chem* **52**, 801–808.
- Chet, I., Trojanowski, J. and Huttermann, A. (1985). Decolorization of the poly B-411 and its correlation with lignin degradation by fungi. *Microbiol Lett* **29**, 37–43.
- Chibata, I., Tosa, T. and Tokata, I. (1983). Continuous production of L-malic acid by immobilized cells. *Trends Biotechnol* **1**, 9–11.
- Christensen, T.H., Kjeldsen, P.A. and Lindhardt, B. (1996). Gas generating processes in landfills. In *Landfilling of waste: Biogas* (T.H. Christensen, R. Cossu and R. Stegman, eds). E and FN Spon, London.
- Concalves, F., Fernandes, C., Cameira dos Santos, P. and Norberta de Pinho, M. (2003). Wine tartaric stabilization by electro dialysis and its assessment by the saturation temperature. *J Food Engin* **59**, 229–235.
- Converti, A., Drago, F., Ghiazza, G., Del Borghi, M. and Macchiavello, A. (1997). Co-digestion of municipal sewage sludges and pre-hydrolysed woody agricultural wastes. *J Chem Technol Biotechnol* **69**, 231–239.
- Converti, A., Del Borghi, A., Zilli M., Arni, S. and Del Borghi, M. (1999). Anaerobic digestion of the vegetable fraction of municipal refuses: mesophilic versus thermophilic conditions. *Bioprocess Engin* **21**, 371–376.
- Cooper, P.F. and Atkinson, B. (1981). *Biological fluidised bed treatment of water and wastewater*. Ellis Horwood Ltd./Water Research Centre, Chichester.
- Corbitt, R. (1990). Methods of composting. In *Standard handbook of environmental engineering*, pp. 382. McGraw-Hill Inc., New York.
- Cox, G. and Baker, R.W. (1998). Pervaporation. *Indust Wastewater*, 35–38.

- Dacey, J. (1967). Active carbon. In *The solid–gas interface* (E. Flood, ed.), pp. 995. Marcel Dekker, New York.
- Decloux, M., Bories, A., Lewandowski, R. *et al.* (2002). Interest of electro dialysis to reduce potassium level in vinasses. Preliminary experiments. *Desalination* **146**, 393–398.
- Diaz, M., Madejon, E., Lopez, F., Lopez, R. and Cabrera, F. (2002) Optimization of the rate vinasse/grape marc for co-composting process. *Process Biochem* **37**, 1143–1150.
- Diez-Blanco, V., Garcia-Encina, P. and Fernandez-Polanco, F. (1995). Effect of biofilm growth, gas and liquid velocities on the expansion of an anaerobic fluidized bed reactor. *Water Res* **29**, 1649–1654.
- Ekinski, K., Keener, H.M., Michael, F.C. and Elwell, D.L. (2001). Effects of temperature and initial moisture content on the composting rate of short paper fiber and broiler litter. ASAE Annual meeting, California.
- Encinar, J., Beltran, F., Gonzalez, J. and Moreno, M. (1997). Pyrolysis of maize, sunflower, grape and tobacco residues. *J Chem Technol Biotechnol* **70**, 400–410.
- Encinar, J., Beltran, F., Bernalte, A., Biro, A. and Gonzalez, F. (1996). Pyrolysis of two agricultural residues: olive and grape bagasse. Influence of particle size and temperature. *Biomass Bioenergy* **11**, 397–409.
- Environmental Act (1995). HMSO, London, U.K.
- Estaben, M., Polit, M. and Steyer, J. (1997). Fuzzy control for an anaerobic digester. *Control Engin Pract* **5**, 1303–1310.
- European Commission (2004). Integrated pollution prevention and control. Draft reference document on the best available techniques for waste incineration. European Commission, Brussels.
- Ferrer, J., Paez, G., Marmol, Z. *et al.* (2001). Agronomic use of biotechnologically processed grape wastes. *Bioresource Technol* **76**, 39–44.
- Fripiat, J., Bol, T., Binot, R. and Nyns, E. (1984). *A strategy for the evaluation of methane production from different types of substrate biomass*. Roger Bowskill Ltd, Exeter.
- Gallert, C. and Winter, J. (1997). Mesophilic and thermophilic anaerobic digestion of source-sorted organic wastes: effect of ammonia on glucose degradation and methane production. *Appl Microbiol Biotechnol* **48**, 405–410.
- Garcia-Calderon, D., Buffiere, P., Moletta, R. and Elmaleh, S. (1998). Anaerobic digestion of wine distillery wastewater in down-flow fluidized bed. *Water Res* **32**, 3593–3600.
- Genovesi, A., Harmand, J. and Steyer, J. (1999). A fuzzy logic based diagnosis system for the on-line supervision of an anaerobic digester pilot-plant. *Biochem Engin J* **3**, 171–183.
- Gervais, C. (2002). *An overview of European Waste and Resource Management Policy*. Forum for the future, London.
- Glaze, W., Kang, J. and Chapin, D. (1987). The chemistry of water treatment processes involving ozone, hydrogen peroxide and ultraviolet radiation. *Ozone Sci Eng* **9**, 335–352.
- Golueke, C.G. (1973). Composting – a study of the process and its principles. In *Emmaus*, pp. 110. Rodale Press.
- Hammer, M.J. and Hammer, M.J. Jr (2004). *Water and wastewater technology*, 5th edn, pp. 388, 424, 431, 437, 441, 452. Pearson Education International, New Jersey.
- Harrison, R.M. (2001). *Pollution causes, effects and control*. Royal Society of Chemistry, London.

- Haug, R. (1993). *The Practical Handbook of Compost Engineering*. Lewis Publishers, Boca Raton.
- Hohenstein, W. and Wright, L. (1994). Biomass energy production in the United States, an overview. *Biomass Bioenergy* **6**, 161.
- Hoigne, J. (1998). Chemistry of aqueous ozone and transformation of pollutants by ozonation and advanced oxidation processes. In *The handbook of environmental chemistry, quality and treatment of drinking water II*, Vol. 5 Part C, (J. Hrubeck, ed.). Springer, Berlin.
- Houbron, E., Torrijos, M. and Moletta, R. (1998). Application de procede SBR aux effluents vinicoles. Resultats de trois annees de suivi. In *2eme Congres International sur le Traitement des Effluents Vinicoles*, pp. 189–196. Cemagref – DICOVA, Bordeaux.
- Inbar, Y., Chen, Y., Hadar, Y. and Verdonck, O. (1988). Composting of agricultural wastes for their use as container media: simulation of the composting process. *Biol Wastes* **26**, 247–259.
- Inbar, Y., Chen, Y. and Hadar, Y. (1992). Characterization of humic substances formed during the composting of solid wastes from wineries. *Sci Total Environ* **113**, 35–48.
- Ingelmo, F., Canet, R., Ibañez, M., Pomares, F. and García, J. (1998). Use of MSW compost, dried sewage sludge and other wastes as partial substitutes for peat and soil. *Bioresource Technol* **63**, 123–129.
- Israilides, C., Smith, A., Harthill, J., Barnett, C., Bambalov, G. and Scanlon, B. (1998). Pullulan content of the ethanol precipitate from fermented agro-industrial wastes. *Appl Microbiol Biotechnol* **49**, 613–617.
- Jekel, M. (1994). Flocculation effects of ozone. *Ozone Sci Engin* **16**, 55–64.
- Kirk, T. and Farrell, R. (1987). Enzymatic combustion: the microbial degradation of lignin. *Ann Rev Microbiol* **41**, 465–505.
- Kirk, R.E. and Othmer, D.F. (1979). *Encyclopaedia of Chemical Technology* (H.F. Mark, D.F. Othmer, C.G. Overberger and G.F. Seaborg, eds), pp.1042–1053. Interscience Pub., New York.
- Kjallstrand, J., Ramna, O. and Petersson, G. (1998). Gas chromatographic and mass spectrometric analysis of 36 lignin-related methoxyphenols from uncontrolled combustion of wood. *J Chromatogr A* **824**, 205–210.
- Kjeldsen, P., Barlaz, M.A., Rooker, A.P., Baun, A., Ledin, A. and Christensen, T.H. (2002). Critical review. *Environ Sci Technol* **32**, 297–336.
- Kulku, R. and Yaldiz, O. (2004). Determination of aeration and kinetics of composting some agricultural wastes. *Bioresource Technol* **93**, 49–57.
- Lane, P. and Peto, M. (1995). *Blackstone's Guide to the Environment Act 1995*. Blackstone Press Ltd., London.
- Langlais, B., Reckhow, D. and Brink, D. (1991). *Ozone in water treatment, application and engineering*. Lewis Publishers Inc., Chelsea.
- Lanting, J., Jordan, J., Schone, M. and Kitney, B. (1989). Thermophilic anaerobic digestion of coffee wastewater. In *Proceedings of the 43rd Purdue Industrial Waste Conference*, pp. 513–524. Lewis Publications, Michigan.
- Leckner, B. and Lyngfelt, A. (2002). Optimization of emissions from fluidized bed combustion of coal, biofuel and waste. *Int J Energy Res* **26**, 1191–1202.

- Legrini, O., Oliveros, E. and Braun, A. (1993). Photochemical processes for water treatment. *Chem Rev* **93**, 671–698.
- Leonowicz, A., Matuszewka, A., Luterek, J. *et al.* (1999). Biodegradation of lignin by white rot fungi. *Fungal Genet Biol* **27**, 175–185.
- Lin, S.H. and Chuang, T. S. (1994). Wet air oxidation and activated sludge treatment of phenolic wastewater. *J Environ Sci Hlth* **A29**, 547–564.
- Lionel, D. and Higgs, G.J.C. (1966). Improvements in or relating to the preparation of weak acids from their salts by electro dialysis. UK Patent 1 030 969, 1966.
- Lissens, G., Thomsen, A.B. and De Baere, L. (2004). Thermal wet oxidation improves anaerobic biodegradability of raw and digested biowaste. *Environ Sci Technol* **38**, 3418–3424.
- Loening, A. (2003). Predictions and projections; looking at the power generation potential of landfill gas, Waste management world. International Solid Waste Management Association, Copenhagen, November–December.
- Mace, S. and Mata-Alvarez, J. (2002). Utilization of SBR technology for wastewater treatment: an overview. *Indust Engin Chem Res* **41**, 5539–5553.
- Mackay, D. and Roberts, P. (1984). The dependence of char and carbon yield on lignocellulosic precursor composition. *Carbon* **20**, 95.
- Madejon, E., Diaz, M., Lopez, R. and Cabrera, F. (2001). Co-composting of sugarbeet vinasse: influence of the organic matter nature of the bulking agents used. *Bioresource Technol* **76**, 275–278.
- Manios, T. (2004). The composting potential of different organic solid wastes: experience from the island of Crete. *Environ Int* **29**, 1079–1089.
- Mantzavinos, D., Hellenbrand, R., Livingston, A. and Metcalfe, I. (1996a). Catalytic wet oxidation of *p*-coumaric acid: partial oxidation intermediates, reaction pathways and catalyst leaching. *Appl Catalysis* **7**, 379–396.
- Mantzavinos, D., Hellenbrand, R., Livingston, A. and Metcalfe, I. (1996b). Partial wet oxidation of *p*-coumaric acid: oxidation intermediates, reaction pathways and implications for wastewater treatment. *Water Res* **30**, 2969–2976.
- Mariani, G., Benfenati, E., Fanelli, R., Nicoli, A., Bonfitto, E. and Jacopone, S. (1992). Incineration of agro-industrial wastes and macro- and micropollutants emission. *Chemosphere* **24**, 1545–1551.
- Mata-Alvarez, J., Llabres, P., Cecchi, F. and Pavan, P. (1992). Anaerobic digestion of the Barcelona central food market organic wastes: experimental study. *Bioresource Technol* **39**, 39–48.
- McBean, E., Rovers, F. and Farquhar, G. (1995). *Solid Waste Landfill Engineering and Design*. Prentice Hall, Englewood Cliffs.
- McLanaghan, S.R.B. (2002). Delivering the landfill directive: the role of new and emerging technologies. *Report for the Strategy Unit: 0008/2002*. PMSU, London.
- Meier, D. and Faix, O. (1999) State of the art of applied fast pyrolysis of lignocellulosic materials – a review. *Bioresource Technol* **68**, 71–77.
- Menachem, L. and Goklestein, I. (1984). Wood structure and composition. *International Fibre Science*. Marcel Dekker Inc., New York.
- Mendez-Acosta, H.O., Femat, R. and Campos-Delgado, D. (2004). Improving the performance on the chemical oxygen demand regulation in anaerobic digestion. *Indust Engin Chem Res* **43**, 95–104.

- Metcalf and Eddy Inc. (1991). *Wastewater Engineering, Treatment, Disposal and Reuse*. McGraw-Hill Inc, New York.
- Moldes, D., Gallego, P.P., Rodriguez-Couto, S. and Sanroman, A. (2003). Grape seeds: the best lignocellulosic waste to produce laccase by solid state cultures of *Trametes hirsuta*. *Biotechnol Lett* **25**, 491–495.
- Moletta, R., Verrier, D. and Albagnac, G. (1986). Dynamic modelling of anaerobic digestion. *Water Res* **20**, 427–434.
- Mourques, F., Brisset, M. and Chevreau, E. (1998). *Trends Biotechnol* **16**, 203–212.
- Naveau, H., Nyns, E., Binot, R. and Delafontaine, M. (1979). Recycling of effluents and organic residues into methane by anaerobic digestion. New perspectives. In *Recycling Berlin '79*, vol. 2 (K.J. Thome-Kozmiensky, ed.), pp. 783–788. E. Freitag, Berlin.
- Novotny, C., Rawal, B., Bhatt, M., Patel, M., Sasek, V. and Molotoris, H. (2001). Capacity of *Irpex lacteus* and *Pleurotus ostreatus* for decolorization of chemically different dyes. *J Biotechnol* **89**, 113–122.
- Pandey, A., Selvakumar, P., Soccol, C. and Nigam, P. (1999). Solid state fermentation for the production of industrial enzymes. *Curr Sci* **77**, 149–162.
- Pearson, H., Weinberg, C. and Whitsell, W. (1953). Thermophilic digestion of monosodium-glutamate end liquor. In *Proceedings of the 8th Purdue Industrial Waste Conference*, pp. 275–283. Purdue University.
- Perez, M., Romero, L. and Sales, D. (2001). Organic matter degradation kinetics in an anaerobic thermophilic fluidised bed bioreactor. *Anaerobe*, **7**, 25–35.
- Perez, M., Romero, L. and Sales, D. (1998). Comparative performance of high rate anaerobic thermophilic technologies treating industrial wastewater. *Water Res* **32**, 559–564.
- Ranalli, G., Bottura, G., Taddei, P., Garavani, M., Marchetti, R. and Sorlini, C. (2001). Composting of solid and sludge residues from agricultural and food industries. Bioindicators of monitoring and compost maturity. *J Environ Sci Health* **36**, 415–436.
- Rice, R. (1981). Ozone treatment of hazardous materials. *AIChE Symposium series* **77**, 79–107.
- Rice, R. (1999). Ozone in the United States of America. State of the art. *Ozone Sci Eng* **21**, 99–118.
- Richard, T.L. (1992). Municipal solid waste composting: biological processing. *Biomass and Bioenergy* **3**(3–4), 163–180.
- Rodríguez-Couto, S., Gundín, M., Lorenzo, M. and Sanromán, A. (2002). Screening of supports for laccase production by *Trametes versicolor* in semi-solid-state conditions. *Process Biochem* **38**, 249–255.
- Rodríguez-Couto, R., Rodríguez, S., Gallego, R. and Sanroman, P. (2003). Biodegradation of grape cluster stems and ligninolytic enzyme production by *Phanerochaete chrysosporium* during semi-solid-state cultivation. *Acta Biotechnol* **23**, 65–74.
- Royse, D. (1997). Specialty mushrooms: consumption, production and cultivation. *Rev Mex Micol* **13**, 1–11.
- Sanchez, A., Ysunza, F., Beltran-Garcia, M. and Esqueda, M. (2002). Biodegradation of viticulture wastes by *Pleurotus*: a source of microbial and human food and its potential use in animal feeding. *J Agricult Food Chem* **50**, 2537–2542.
- Santos, M., Fernandez-Bocanegra, J., Martín, M. and Garcia, G. (2003). Ozonation of vinasse in acid and alkaline media. *J Chem Technol Biotechnol* **78**, 1121–1127.

- Schmidt, A. S. and Thomsen, A. B. (1998). Optimization of wet oxidation pretreatment of wheat straw. *Bioresource Technol* **64**, 139–151.
- Scott, J. and Ollis, D. (1995). Integration of chemical and biological processes for water treatment: review and recommendations. *Environ Prog* **14**, 88–103.
- Shafizadeh, F. (1982). Introduction to pyrolysis of biomass. *J Analyt Appl Pyrolysis* **3**, 283.
- Shieh, W. and Hsu, Y. (1996) Biomass loss from an anaerobic fluidized bed reactor. *Water Res* **30**, 1253–1257.
- Shinogia, Y. and Kanrib, Y. (2003). Pyrolysis of plant, animal and human waste: physical and chemical characterization of the pyrolytic products. *Bioresource Technol* **90**, 241–247.
- Sixt, H. and Sahn, H. (1987) Biomethanation. In *Biotechnology of waste treatment and exploitation* (J.M. Sidwich and R.S. Holdom, eds), pp. 147–172. Ellis Horwood Ltd, Chichester.
- Smagge, F, Mourgues, J., Escudier, J., Conte, T., Molinier, J. and Malmary, C. (1992). Recovery of calcium tartrate and calcium malate in effluents from grape sugar production by electro dialysis. *Bioresource Technol* **39**, 85–189.
- Solisio, C., Palazzi, E. and Del Borghi, M. (1987). Performance of an anaerobic fixed-film bioreactor for treatment of a settled domestic sewage. *Proceedings of the 4th European Congress on Biotechnology*, Vol. 1, pp. 214–217. Amsterdam, 14–19 June.
- Swan, J.R.M., Crook, B. and Gilbert, E.J. (2002). Issues. *Environ Sci Technol* **28**, 151–173.
- Tartakovsky, B., Morel, E., Steyer, J. and Guiot, S. (2002). Application of a variable structure model in observation and control of an anaerobic digester. *Biotechnol Prog* **18**, 898–903.
- Thompson, L.H. and Doraiswamy, L.K. (1999). Sonochemistry: science and engineering. *Ind Eng Chem Res* **38**, 1215–1249.
- Torrigos, M. and Moletta, R. (1997). Winery wastewater depollution by sequencing batch reactor. *Water Sci Technol* **35**, 2497.
- Tsutsui, T., Hayashi, N., Maizumi, H., Huff, J. and Barrett, J. (1997). Benzene, catechol, hydroquinone and phenol induced cell transformation, gene mutations, chromosome aberrations, aneuploidy, sister chromatid exchanges and unscheduled DNA synthesis in Syrian hamster embryo cells. *Mutant Res* **373**, 113–123.
- Vail, M., Gubler, W. and Adaskaveg, J. (1995). First report of *Pleurotus ostreatus* causing a wood rot of grapevines in California vineyards. *Plant Dis* **79**, 1187.
- Vlissidis, A. and Zouboulis, A. (1993). Thermophilic anaerobic digestion of alcohol distillery wastewaters. *Bioresource Technol* **43**, 131–140.
- Westlake, K. (1995). *Landfill pollution and control*. Albion Publishing, Chichester.
- Wheatley, A. (1990). *Anaerobic Digestion. A Waste Treatment Technology*. Elsevier Applied Science, London.
- Whiting, K.J. (2003). Incineration of municipal solid waste. University of Leeds short course, University of Leeds, Leeds.
- Whiting, K.J. (2001). Proceedings of the 3rd International Symposium on Waste Treatment Technologies, Brussels, pp. 1, 13. Institution of Chemical Engineers Publications, Rugby.
- Williams, P.T. (2001). *Chemical Engin* **717**, 24–27.
- Williams, P.T. (2005). *Waste treatment and disposal*. John Wiley, Chichester, U.K.

- Wohlt, J., Frobish, R., Davis, C., Bryant, M. and Mackie, R. (1990). Thermophilic methane production from dairy cattle waste. *Biol Wastes* **32**, 193–207.
- Yaman, S. (2004). Pyrolysis of biomass to produce fuels and chemical feedstocks. *Energy Conversion Manage* **45**, 651–671.

Electronic sources

- <http://www.cpeo.org/techtree/ttdescript/ensolmx.htm>
- <http://www.modflow.bossintl.com/html/exsitu-bioremediation.html>
- <http://ewr.cee.vt.edu/environmental/teach/gwprimer/bioreact/bior.html>
- <http://www.icar.cnr.it/spezzano/colombo/bioris/cortesto.htm>
- <http://www.biotech-monitor.nl/3405.htm>
- http://www.esru.strath.ac.uk/EandE/Web_sites/97-8/energy_from_waste/page3.htm
- http://www.frtr.gov/matrix2/section4/4_13.html
- <http://www.iupac.org/publications/pac/2001/pdf/7307x1163.pdf>
- <http://www.epa.gov/swerust1/cat/biopiles.htm>
- <http://www.modflow.bossintl.com/html/exsitu-bioremediation.html>
- http://www.frtr.gov/matrix2/section4/4_11.html
- <http://modflow.bossintl.com/html/insitu-bioremediation.html>
- <http://www.accessexcellence.org/LC/ST/st3bg.html>
- <http://www.lanl.gov/orgs/d/d4/enviro/etcap/overview.html>
- http://www.wasteonline.org.uk/resources/Wasteguide/mn_wmo_thermtreatment_incin.html
- <http://www.bizasianetwork.com/Trends%20and%20technologies%20for%20hazardous%20waste%20disposal.htm>
- <http://www.hazardouswaste.utah.gov/incin1.htm>
- http://www.frtr.gov/matrix2/section4/4_26.html
- <http://www.reslab.com.au/resfiles/waste/text.html>
- <http://www.frtr.gov/matrix2/section4/4-23.html>
- http://www.nett21.gec.jp/CTT_DATA/WASTE/WASTE_3/html/Waste-095.html
- <http://www.frtr.gov/matrix2/section4/4-25.html>
- http://www.frtr.gov/matrix2/section4/4_28.html
- http://www.nett21.gec.jp/JSIM_DATA/WASTE/WASTE_3/html/Doc_433.html
- http://www.nett21.gec.jp/JSIM_DATA/WASTE/WASTE_5/html/Doc_509_1.html
- <http://www.age.psu.edu/extension/factsheets/c/C3.pdf>
- <http://www.tristate.apogee.net/et/ewtwmsd.asp>
- <http://www.foe.co.uk/pubsinfo/briefings/html/20021008124332.html>
- <http://www.acarp.com.au/Completed/abstracts/C9066abstract.htm>
- <http://www.frontlinebioenergy.com/id17.html>
- <http://www1.sac.ac.uk/envsci/External/WillowPower/Conversn.htm>
- [http://yosemite.epa.gov/r8/r8media.nsf/\(BreakingNews\)/25C1C328881A26DB87256FBA00675504](http://yosemite.epa.gov/r8/r8media.nsf/(BreakingNews)/25C1C328881A26DB87256FBA00675504)
- http://www.energyproducts.com/fluidized_bed_gasifiers.htm <http://www.fao.org/docrep/X5328e/x5328e05.htm>
- <http://www.gtp-merichem.com/news/releases/syngas.html>

<http://www.fao.org/docrep/T0275E/T0275E02.htm>
<http://www.zenithenergy.com/BioGasfr.html>
http://www.edie.net/products/view_entry.asp?id=1386&channel=0
http://www.aquatechnologies.com/info_activated_carbon.htm
<http://www.ecy.wa.gov/pubs/96414.pdf>
<http://www.es.epa.gov/techinfo/facts/michigan/michfs20.html>
<http://www.wastewaterevaporators.com/>
<http://www.tristate.apogee.net/et/extse.asp>
http://www.actionenergy.org.uk/energywizard/technology_guides.asp?sectionId=TG&code=gb0069
<http://www.niroinc.com/html/news/bg033101.html>
http://www.gea-wiegand.com/ndk_website/geawiegand/cmsdoc.nsf/WebDoc/ndkw5r9b7x
<http://www.foodsci.uoguelph.ca/dairyedu/membrane.html>
http://www.pollutionengineering.com/CDA/ArticleInformation/features/BNP_Features_Item/0,6649,106432,00.html
<http://www.www.pacificro.com/Solutio2.htm>
<http://www.gewater.com/pdf/TechNotes/TN%20120%20Glossary%20of%20Terms.pdf>
<http://www.bccresearch.com/membrane/DMD00.html>
http://www.media.wiley.com/product_data/excerpt/56/04708544/0470854456.pdf
<http://www.tifac.org.in/news/memb.htm>
http://separationprocesses.com/Membrane/MT_Chp07d.htm
http://www.enviro.nfesc.navy.mil/erb/erb_a/restoration/technologies/sel_tools/shortlist/shortlist.htm
http://www.gewater.com/library/tp/833_What_Is.jsp
http://www.wholly-water.com/reverse_osmosis/Reverse.Osmosis.htm
http://www.gewater.com/library/tp/835_Ultrafiltration.jsp
<http://www.geafiltration.com/html/technology/ftechnology.html>
<http://www.ameridia.com/html/nab.html>
http://www.acenz.com/filtration_processes/
<http://www.ionics.com/technologies/ed/>
<http://www.lenntech.com/electrodialysis.htm>
<http://www.electrosynthesis.com/ess/weid.html>
<http://www.ionics.com/technologies/ed/>
http://www.facstaff.bucknell.edu/mvigeant/field_guide/pinciotti/project/gas.html
<http://www.cheresources.com/pervaporation.shtml>
<http://www.physchem.co.za/Redox/Electrolysis.htm>
<http://www.lenntech.com/electroplating.htm>
<http://www.corrosion-doctors.org/MetalCoatings/Electroplating.htm>
http://www.sparknotes.com/chemistry/electrochemistry/intro/terms/term_B.3.html
<http://www.crystalinks.com/metallurgy.html>
<http://www.unr.edu/sb204/geology/extract2.html>
<http://www.home.att.net/~cat6a/electrolysis-IV.htm>
<http://www.chembio.uoguelph.ca/etc/waste.html>
<http://tristate.apogee.net/et/ewtwozn.asp>
http://www.gewater.com/library/tp/844_Ozonation.jsp

<http://www.extoxnet.orst.edu/faqs/glossary.htm#sectO>
<http://www.ciwmb.ca.gov/Organics/Conversion/Anaerobic/>
<http://www.energy.ca.gov/development/biomass/anaerobic.html>
http://www.mrc.wa.gov.au/resources/anaerobic_digestion.html
http://www.esru.strath.ac.uk/EandE/Web_sites/03-04/biomass/background%20info8.html
<http://www.mea.org.uk/biogas/systems.htm>
http://www.cogeneration.net/anaerobic_lagoons.htm
http://www.energy.ca.gov/pier/renewable/biomass/anaerobic_digestion/
<http://www.nfec.org/digester.htm>
<http://www-ec.njit.edu/~hsieh/ene670/coagula.html>
<http://www.cpeo.org/techtree/ttdescript/precip.htm>
http://www.waterspecialists.biz/html/about_chemical_precipitation.html
<http://www.powellwater.com/ec-overview.htm>
<http://www.earthpace.com/resources/wwt/coagulation.html>
<http://www.fao.org/DOCREP/003/V9922E/V9922E06.htm>
<http://www.orgchem.colorado.edu/hndbksupport/dist/dist.html>
http://www.actionenergy.org.uk/energywizard/technology_guides.asp?sectionId=TG&code=gb0070
<http://www.chemistry.about.com/cs/5/f/bldistillation.htm>
<http://www.solaqua.com/solstilbas.html#ssback>
http://www.daviddarling.info/encyclopedia/S/AE_solar_distillation.html
<http://www.tifac.org.in/offer/tlbo/memb.htm>
<http://www.tifac.org.in/news/memb.htm>
<http://www.age.psu.edu/extension/factsheets/c/C3.pdf>
<http://www.compost.org/qna.html>
<http://www.eere.energy.gov/consumerinfo/factsheets/nb2.html>
<http://www.ees.adelaide.edu.au/pharris/biogas/pvdv.pdf>
<http://www.engr.uga.edu/service/outreach/publications/biosolids/Ch03-SolidsHandlingProcesses.pdf>
<http://www.janebrook.com.au/diagred.htm>
<http://www.geosp.uq.edu.au/emc/CP/Res/facts/FACT5.HTM>
<http://www.epa.gov/epaoswer/non-hw/composting/static.htm>
<http://gnv.fdt.net/~windle/refrence/jan99.htm>
<http://www.industrytechlink.com.au/newsletter/edition/17.html>
<http://www.ionics.com/toolbox/edr.htm>
<http://www.lagoononline.com/composting.htm>
<http://www.nf-2000.org/secure/FP5/F1738.htm>
http://p2library.nfesc.navy.mil/P2_Opportunity_Handbook/9-IV-5.htm
<http://www.pharm.uoa.gr/dionysos/enenvirom.htm>
<http://www.pro-enteceast.de...hausklarungen.html>
<http://www.platypuswines.com/austwinemaking.html>
<http://www.public.iastate.edu/~tge/struvite.pdf>
http://www.remade.org.uk/Organics/organics_documents/20001001_HBruce_CompTechSystems.pdf
<http://www.rrc.mb.ca/environment/pdffiles/FeasibilityofComposting.pdf>

<http://www.swampni.org.uk/downloads/5193.00%20SWaMP%20WMP%20-%20Section%205.pdf>.

<http://www.tve.org/ho/doc.cfm?aid=1348andlang=English.html>

<http://www.unu.edu/unupress/unupbooks/80434e/80434E09.htm>

<http://www.vermontagriculture.com/whitepaper.pdf>

<http://www.homebrewit.com/winemakers.pdf>

<http://www.woodsend.org/aaa/inst.html>

Waste Treatment Methodologies of Foods of Plant Origin

PART

4

7	Wine Waste Management: Treatment Methods and Potential Uses of Treated Waste	413
8	Olive Oil Waste Management: Treatment Methods and Potential Uses of Treated Waste	453
9	Fruit/Fruit Juice Waste Management: Treatment Methods and Potential Uses of Treated Waste	569
10	Cereal Waste Management: Treatment Methods and Potential Uses of Treated Waste	629
11	Vegetable Waste Management: Treatment Methods and Potential Uses of Treated Waste	703

This page intentionally left blank

Wine Waste Management: Treatment Methods and Potential Uses of Treated Waste

*Ioannis S. Arvanitoyannis, Demetrios Ladas and
Athanasios Mavromatis*

Introduction	413
Wine waste treatment methods	418
Main applications/constituents to be exploited	429

Introduction

Nowadays, there is a growing interest in the exploitation of the residues generated by the wine industry. In particular, winery wastes could be an alternative source for obtaining natural antioxidants which are considered completely safe in comparison with synthetic antioxidants. Moreover, wine waste can be potentially used as soil conditioner or for fertilizer production (Figures 7.1 and 7.2). Furthermore, in this chapter, their utilization as adsorbent and for pollutant production is described. Table 7.1 summarizes both uses and end by-products of winery wastes.

Grape pomace represents a rich source of various high-value products such as ethanol, tartrates and malates, citric acid, grape seed oil, hydrocolloids and dietary fiber. Moreover, grape pomace is characterized by high phenolic contents because of poor extraction during winemaking, making their utilization noteworthy and thus supporting sustainable agricultural production (Kammerer *et al.*, 2004).

In recent years, the use of grape seed extracts (GSE) has gained ground as a nutritional supplement in view of its antioxidant activity (Gonzalez-Paramas *et al.*, 2004).

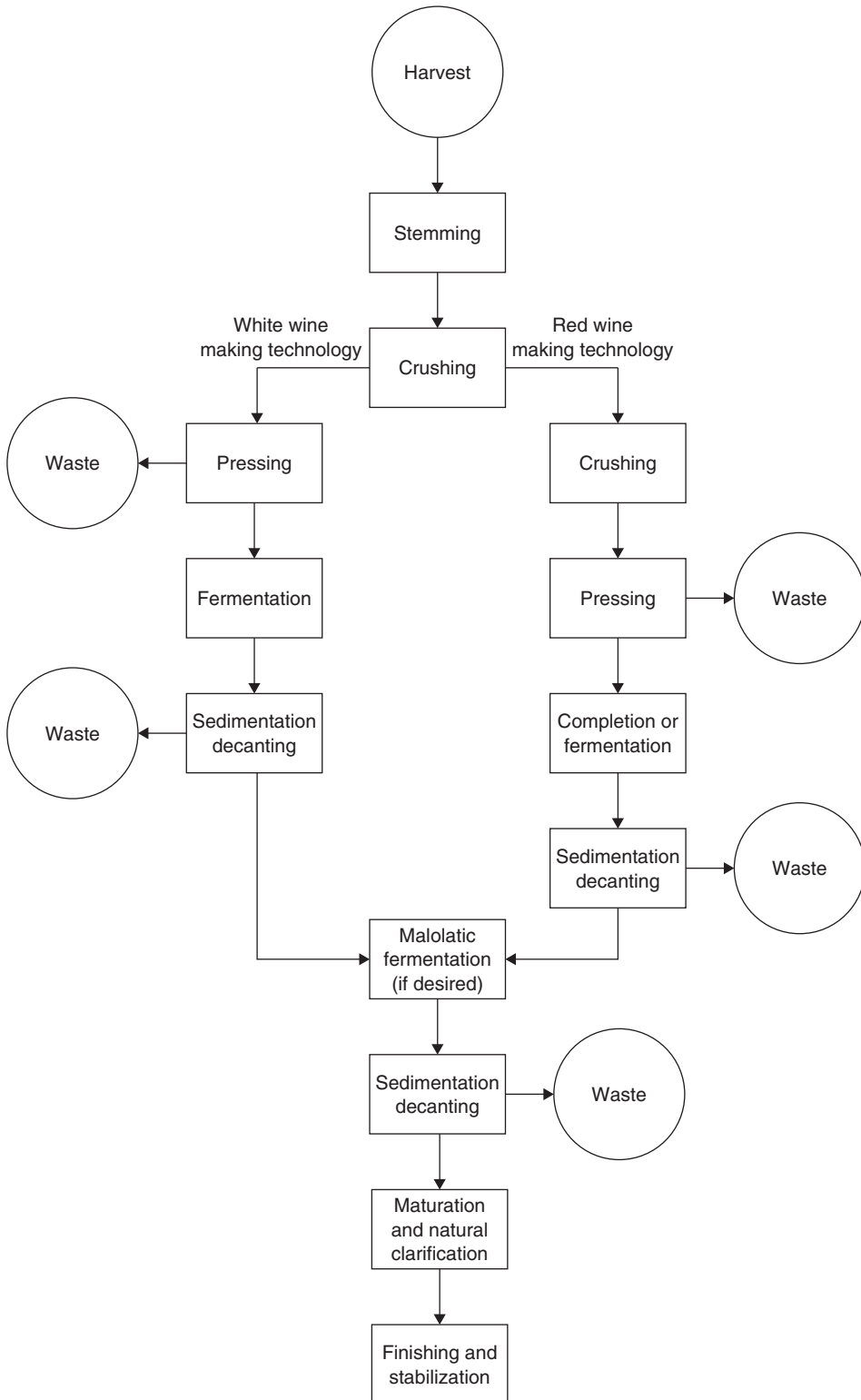

Figure 7.1 Winemaking flow diagram (adapted from www.janebrook.com.au/diagred.html; www.geosp.uq.edu.au/emc/CP/Res/facts/FACT5.HTM; Bustos *et al.*, 2004)

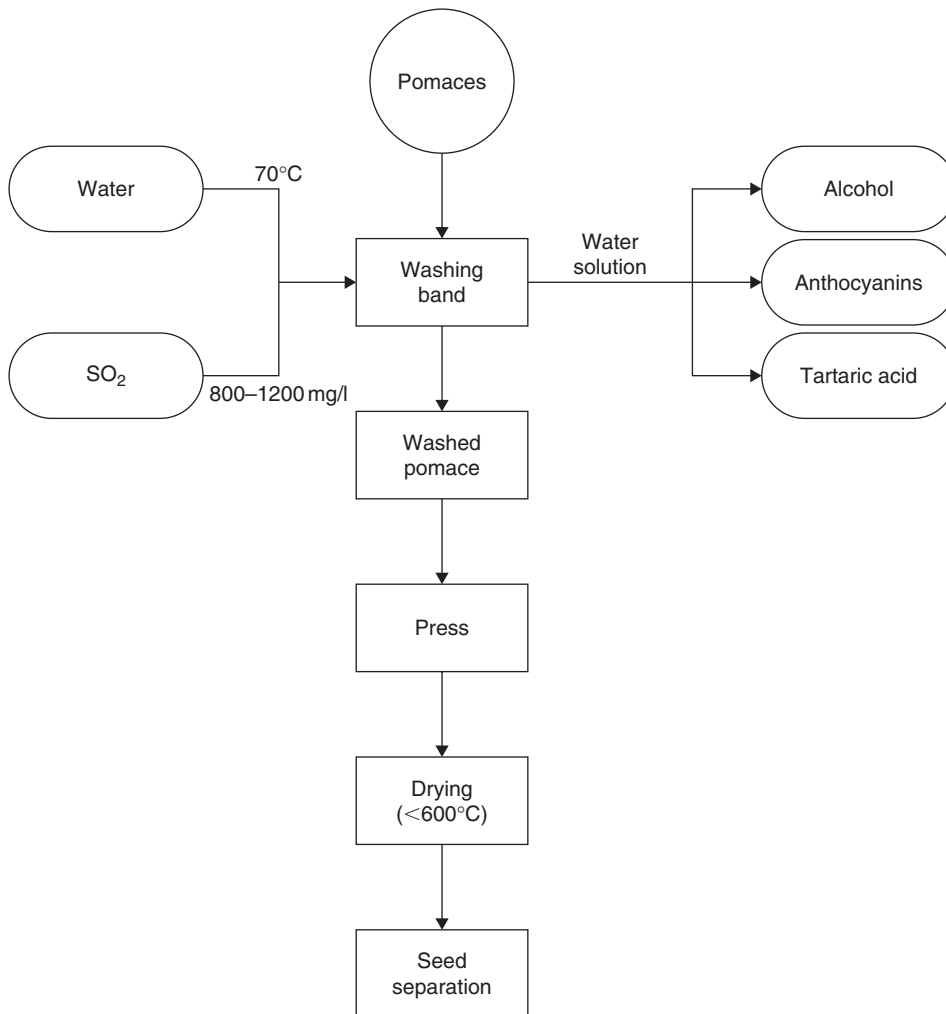

Figure 7.2 Scheme of the process of industrial winery exploitation of the winemaking by-products (adapted from Gonzalez-Paramas *et al.*, 2004)

The by-products obtained after winery exploitation, either seeds or pomaces, constitute a very low cost source for the extraction of antioxidant flavanols, which can be used as dietary supplements, or in the production of phytochemicals, thus providing an important economic advantage (Alonso *et al.*, 2002; Negro, 2003; Gonzalez-Paramas *et al.*, 2004).

Extensive research has demonstrated that many biodegradable organic wastes can be composted in a convenient and economical way. Composting of organic matter is a simple and effective manner of transforming agro-industrial wastes into products suitable for use as soil conditioners (Ferrer *et al.*, 2001). Different substrates, such as tomato waste, cork residues, olive husks and tannery sludge for composting resulted in end products adequate as organic fertilizers in terms of their physicochemical characteristics (Vallini *et al.*, 1983).

Exclusive addition of chemical fertilizers is no longer considered the best method to feed plants and keep plant pathogens under control. Growers understand that they

Table 7.1 Treatment methodology of grape waste

No	Kind of waste	Treatment	Parameters	Methodology	Results	References
1	Grape bagasses	Combustion	Oxygen partial pressure, gas flow rate	Combustion kinetic of grape bagasses	Activation energy combustion between 82.6 and 89.3 kJ/mol	Encinar <i>et al.</i> , 1996
2	Grape cluster stems	Solid-state fermentation	Culture of <i>Phanerochaete chrysosporium</i> , content of lignin, cellulose, hemicellulose	The grape cluster stems were biodegraded by <i>Phanerochaete</i> during semi-solid-state cultivation	Degradation of cellulose 5.3%, lignin 19.7%, hemicellulose 48.6% Consumption of free monosaccharide glucose 1 g/l	Rodriguez-Couto <i>et al.</i> , 2003
3	Dried grape peel and grape stalks	Incineration	PCDD, PCDF, macro- and micro-pollutant concentrations	Burning residual biomass in a pilot plant	Emission of several macro- and micro-pollutants	Mariani <i>et al.</i> , 1992
4	Grape marc	Composting	Aeration, water content, temperature, C/N ratio, O ₂ consumption	Grape marc was incubated in a composting simulator for 10 days	Organic matter 89.1 Max biodegradation at 60% moisture	Verdonck, 1988
5	Grape residues	Pyrolysis	Temperature, heating rate, volatile matter content, gas concentration	Cylindrical stainless steel reactor provided with a heating system, inlets for feeding the gas and accessories to collect liquid and gas samples	0.18–5.37 mole/kg H ₂ production, 0.15–1.2 mole/kg CH ₄ production, 1.8–2.05 mole/kg CO ₂ production, 1.2–3.22 mole/kg CO production, 23–30.82 heating value (MJ/kg charcoal), 9.26–10 heating value (MJ/kg residue)	Encinar <i>et al.</i> , 1997
6	Ion exchange regeneration waters from grape juice treatment	Electrodialysis	Tartrate ion concentration, current efficiency, capital costs, permeate flux of tartrate ion	The wastewaters have been electrodialyzed at 25°C and 40°C aiming at purifying and concentrating tartrate acid	60% concentration of tartrate ion, 65% maximum current efficiency	Andres <i>et al.</i> , 1997
7	Grape pomace, vineyard pruning	Solid-state fermentation	Hemicellulose content, cellulose content, lignin content, totals sugars, total phenols, C/N ratio	Biodegradation of viticulture wastes by <i>Pleurotus</i> spp.	37.2–78.7% biological efficiency, 16.7–38.8% bioconversion	Sanchez <i>et al.</i> , 2002
8	Vinification lees	Solid-state fermentation	Lactid acid production, glucose consumption	Biodegradation of vinification lees by <i>Lactobacillus</i> strains	25.6–103.4 P_{max} and 0.69–1.02 $Y_{p/S}$ (lees from white winemaking technology), 8.9–90.2 P_{max} and 0.62–1.13 $Y_{p/S}$ (lees from red winemaking technology)	Bustos <i>et al.</i> , 2004
9	Grape seeds	Solid-state fermentation	Laccase production, glucose consumption, dye decolorization	Grape seeds were used by <i>Trametes hirsuta</i> as a substrate for laccase production	23 kU/l laccase production, 36–100% dye decolorization	Moldes <i>et al.</i> , 2003

10	Grape residues	Pyrolysis	Temperature, conversion time, gas yields, liquid yields, char yields	Bench-scale plant	0.5–1.3 m/s devolatilization rate, 46–34 wt% mf char yields, 31–40 wt% mf liquid yields, 16–30 wt% mf gas yields	Blasi <i>et al.</i> , 1999
11	Grape bagasse	Pyrolysis	Temperature, particle size, gas yield, liquid yield, solid yield, heating rate	Pyrolysis of grape bagasse in a cylindrical stainless steel reactor provided with a heating system, inlets for feeding the gas and accessories to collect liquid and gas samples	42–44 wt% solid yield, 26.5–31.4 wt% liquid yield, 25.2–29.5 wt% gas yields, 0.004–1.95 heating value (MJ/kg bagasse) of gases, 10.78–20.36 heating value (MJ/kg bagasse) of charcoal, 12.63–20.40 heating value (MJ/kg bagasse) of total	Encinar <i>et al.</i> , 1996
12	Wine vinasses	Thermophilic anaerobic digestion	COD, organic loading rate	Thermophilic anaerobic digestion of wine vinasses in anaerobic fluidized bed (AFB) Thermophilic anaerobic digestion of wine vinasses in up-flow anaerobic fixed-film (UAFF)	23–32 kg COD/m ³ /day maximum organic load rate feed, 75–81.5% organic removal efficiency, 84–97% maximum organic removal efficiency 20 kg COD/m ³ /day maximum organic load rate feed, 50% organic removal efficiency, 75% maximum organic removal efficiency	Perez <i>et al.</i> , 2001
13	Grape marc	Composting	pH, organic matter, temperature, inorganic nitrogen content, moisture content	Composting was carried out in aerated piles with mechanical turning every 10 days and watered regularly to maintain moisture content at 45–50%	4.5–9.6 decomposition rate after 63 days of treatment	Madejon <i>et al.</i> , 2001

Adapted from Arvanitoyannis *et al.*, 2006a

must add some type of organic material to soil, whether it is compost or another type of organic amendment. This organic matter increases microbial biomass and helps maintain beneficial bacterial and fungi populations (<http://www.jgpress.com/BCArticles/2000/070030.html>). Moreover, there are economic benefits, since use of residues means lower costs than those pertaining to conventional materials, with consequent improved competition between user companies (Abad, 1991).

In the case of winery wastes, Diaz *et al.* (2002) reported that the grape marc, a primary waste of wine production, could be recycled as a soil conditioner in view of its organic and nutrient contents. Moreover, a comparison of the best compost obtained from winery wastes with those from other organic wastes showed that its chemical values fell within the same range in most cases, with the exception of a high calcium value owing to the nature of the winemaking process (Soliva and Felipo, 2001; Bertran *et al.*, 2004).

Winery waste sludge was shown to be an effective adsorbent for the adsorption of heavy metals from aqueous solutions. Metal sorption occurs by means of several mechanisms that quantitatively and qualitatively differ according to the metal species in solution and the origin and processing of the sorbent (Villaescusa *et al.*, 2004; Yuan-shen *et al.*, 2004). It is noteworthy that the properties of winery waste are similar to those of other adsorbents, providing it with the ability to adsorb heavy metals (Yuan-shen *et al.*, 2004).

Grape skin pulp should be considered as the best substrate for pullulan production (Israilides *et al.*, 1998). Hot water extracts of the pulp can serve as a good substrate for fermentation with *Aerobasidium pullulans* for the production of pullulan (Arapoglou *et al.*, 2002). Moreover, it was shown that the pullulan produced from winery waste was of high molecular weight (4.22×10^6) and rather pure as determined by its gel elution profile, glucose content and the number of residues in repeating units (Israilides *et al.*, 1994). Table 7.2 summarizes the treatment of grape wastes, the physicochemical properties and their uses.

Wine waste treatment methods

Sequencing batch reactor (SBR)

Smaller wineries and, in particular, independent growers, both of which have a relatively modest financial capacity as well as limited workers, are looking for simple, inexpensive depollution systems with minimum operation and maintenance requirements. Of the possible solutions for dealing with winery wastewater, biological treatment processes are especially attractive because this type of effluent is very readily biodegradable (Torrigos and Molleta, 1997). Consequently, in response to the demands of small producers, SBR technology seems to be suitable to the specific nature of winery wastes.

An example of an SBR technology treatment plant comprised the following:

- 1 two storage tanks of 65 m^3 each, equipped with a transfer pump to feed the influent to the treatment tank

Table 7.2 Treatment of grape waste physicochemical properties and their use

No	Final products	Treatment	Physicochemical characteristics	Uses	References
1	Grape waste	Composting of grape waste and hen droppings	Organic matter content	Fertilizer for corn seed	Ferrer <i>et al.</i> , 2001
2	Grape seed and skin extracts	Fractionation of grape seed and skin extracts from grape waste	Phenol content	Dietary supplements for disease prevention	Shrikhande, 2000
3	Grape waste	Gasification of waste products from grape	Concentrations of unused residues	Gas production for heating purposes	Blasi <i>et al.</i> , 1999
4	Grape marc	Composting of solid wastes and wastewaters	Organic matter content	Fertilizer for ornamental plants and for revegetating sealed landfills	Ingelmo <i>et al.</i> , 1998
5	Pressed grape skin	Composting of solid waste and wastewater	Organic matter content	Fertilizer	Manios, 2004
6	Wine pomace and grape seeds	Lyophilization and extraction of flavanols	Flavanol content	Dietary supplements, production of phytochemicals	Gonzales-Paramas <i>et al.</i> , 2004
7	Grape marcs, stalks and dregs	Lyophilization and extraction of polyphenols	Polyphenolic content	Dietary supplements	Alonso <i>et al.</i> , 2002
8	Grape skins, seeds and stems	Acidolysis of a polymeric proanthocyanidic fraction of grape pomace in the presence of cysteamine	Flavanol content	Source of flavanols	Torres and Bobet, 2001
9	Grape seed extract	Pre- and post-mortem use of grape seed in feeding experiment	Phenol content	Feedstuff for dark poultry meat	Lau and King, 2003
10	Grape skin pulp	Fermentation by <i>Aureobasidium pullulan</i>	Ethanol precipitate	Pullulan production	Israilides <i>et al.</i> , 1998
11	Grape seeds	Solid-state cultivation by <i>Trametes hirsuta</i>	Lignocellulosic content	Laccase production	Moldes <i>et al.</i> , 2003
12	Grape pomace	Solid-state cultivation by <i>Pleurotus</i> spp.	Pruning content, high phenolic components and total sugars	Feedstuff for animals	Sanchez <i>et al.</i> , 2002
13	Wastewater	Electrodialysis	Tartaric acid content	Additive in medicines and cosmetics, acidulant compound in soft drinks	Andres <i>et al.</i> , 1997
14	Wastewater	Electrodialysis at 60°C	Tartaric acid and malic acid content	Food and pharmaceutical industries	Smagge <i>et al.</i> , 1992

Adapted from Arvanitoyannis *et al.*, 2006b

- 2 an aerobic treatment tank of 40 m³ fitted with 36 fine bubble diffusers
- 3 a primary settling tank of 1 m³
- 4 an intermediate retention trough of 3 m³
- 5 a blower and a pump for removing the water after treatment and decanting.

Prior to any operation, the biotreatment processing tank was filled with the winery wastewaters and then seeded at 10% with activated sludge from urban sewage works. During a 7-day start-up period, the reactor functioned in batch mode to vent biomass buildup and acclimatize the sludge to winery wastewater. At the end of the continuous aeration (7 days), the SBR treatment process was set in motion.

The steps of operating cycle are the following:

- 1 continuous aeration/stirring for 20 hours
- 2 decanting for 3 hours
- 3 after decanting, pumping off the clarified wastewater
- 4 once the desired volume had been drawn off, the fill period is start-up using the influent transfer pump to feed wastewater to the aerobic reactor
- 5 restart of the aeration/stirring phase 4 hours after the aerator had been turned off
- 6 end of filling stage, when the 40 m³ reactor tank was full, automatic switch-off occurred by the level gauge of the influent transfer pump.

The results, as well as the simplified automation, the low capital costs and the moderate operating cost, showed that the process is well suited for the depollution of wastewater from small wineries.

Anaerobic digestion

Anaerobic fermentation is an important process used for recycling solid organic waste, which leads to a significant reduction of the waste volume with the production of biogas as a positive side effect. For state observation and control purposes, a mathematical representation of the process is required. However, anaerobic fermentation is far too complex to be described in full metabolic details, due to the variety of responsible microorganisms and the unknown and time-varying waste composition. The level of complexity of the description is limited by the amount and quality of available experimental data which can be used for model identification. In practice, the derivation of a dynamic process model involves the following steps:

- 1 the selection of suitable macroscopic reaction schemes and kinetic structures
- 2 the estimation of the unknown model parameters from experimental data by minimizing a maximum-likelihood criterion
- 3 the estimation of the unknown measurement variances
- 4 the estimation of the covariance matrix of the parameter estimates
- 5 the validation of the obtained model.

A study was conducted to discuss, through a real-case study, a procedure for model structure selection (and simplification) based on the examination of several macroscopic reaction pathways (and in particular the number of biomass types that have to be distinguished), together with the available rare and global measurements. A simple model was developed for an aerobic waste treatment process, considering only two

types of biomass, which is shown to be the maximum number of distinguishable microorganisms from the available measurement data. Although the model is restricted to a very microscopic view of the biodegradation process, the identifiability can be guaranteed in this case. Estimates for the parameters were calculated by minimizing a maximum-likelihood criterion, which resulted in prediction curves in good agreement with the measurement data, even though the uncertainty on the estimated parameters remained at a relatively high level. However, compared to the quality of the measurements, the developed model, together with the determined set of parameters, seems to be an appropriate basis for further use in state observers, which is the intended application of the model (Haag *et al.*, 2003).

The reactor consisted of a column with a conic bottom of a total volume of 5 l. The flow distributor and the gas outlet were placed at the removable cap covering the top section. The effluent was discharged through a port on the low part of the column, connected to an outlet tube keeping the liquid level in the reactor. The reactor temperature was kept constant at 35°C with a water jacket. Before starting-up the reactor, physical and fluidization properties of the carrier material were determined. The reactor was inoculated with sludge from wine distillery wastewater whose composition is given in Table 7.3. No nutrient complements were added. The wine distillery wastewater was kept in a refrigerator to avoid fermentation and was continuously agitated with a magnetic stirrer to ensure homogenization. Anaerobic conditions in the reactor were obtained by bubbling with nitrogen gas. The bed was expanded at 35%, at a superficial liquid velocity of 9 m/h. Temperature, flow rate, pH and gas production and composition were monitored. In addition, alkalinity, TSS (total suspended solids (kg/m^3)), VSS (volatile suspended solids (kg/m^3)), VFA (volatile fatty acids (kg/m^3)) and TOC (total organic carbon (kg/m^3)), were routinely analyzed. Retention time, based on expanded bed volume, was fixed at 3.3 days and was reduced stepwise to 1.3 days when the steady state was reached, keeping the inlet feed COT (C_{in}) concentration constant (Garcia-Calderon *et al.*, 1998).

Table 7.4 shows the carbon removal yield reached by the system at different HRTs (hydraulic retention times) and percentage of the methane release against ORLs (organic loading rate) ($\text{kg TOC}/\text{m}^3/\text{day}$), after the start-up period. Carbon removal varied between 88 and 98%, showing no dramatic change with HRTs longer than 1.3 days (OLR of $4.6 \text{ kg TOC}/\text{m}^3/\text{day}$). In addition, gas production was found to be affected by changes in ORL, as shown in Table 7.4. Every increase in OLR brought about an increase in gas production rate. At $4 \text{ kg TOC}/\text{m}^3/\text{day}$, gas production decreased and rose again as did carbon removal, while OLR continued to increase.

Table 7.3 Average wastewater composition

TOC	pH	TSS	VSS	VFA
5.5–6.5 kg/m^3	4.5–5	1.2–1.9 kg/m^3	0.9–1.6 kg/m^3	4–5.8 kg/m^3

Adapted from Garcia-Calderon *et al.*, 1998

Table 7.4 Influence of OLR on gas production and gas composition

OLR (kg TOC/m ³ /day)	Methane production (%)	Gas production (l/l/day)
1.7	61.7	0.7
1.9	60	3.8
2.2	62.5	5
2.6	68	5.7
3	66.5	8.2
3.4	64	8.8
4	64.5	9
4.6	64	7

Adapted from Garcia-Calderon *et al.*, 1998

The dynamical modeling of anaerobic digestion has been an active research topic during the last three decades. A wide range of models dealing with anaerobic digestion has been developed (Bernard *et al.*, 2001). Masse and Droste (2000) and Graef and Andrews (1974) developed two dynamic models. Estimates of the kinetics parameters from the abovementioned dynamical models are summarized in Table 7.5.

The implementation of the abovementioned models resulted in a fuzzy logic based diagnosis system for the on-line supervision of an anaerobic digester plant. More specific and detailed diagrams were reported by Genovesi *et al.* (1999), Estaben *et al.* (1997), Bernard *et al.* (2001) and Mendez-Acosta *et al.* (2004), who designed experiments covering a wide range of experimental conditions in order to develop and validate the proposed models. The implementation of several dynamic models in anaerobic digestion proved to be efficient in dynamic conditions and, in particular, during the stabilization phases.

Anaerobic digestion is widely used for wastewater treatment, especially in the food industries. Generally, after the anaerobic treatment, there is an anaerobic post-treatment so that the treated water returns to nature. Several technologies are applied to winery wastewater treatment. Free cells or flocs (anaerobic contact digesters, anaerobic sequencing batch reactors and anaerobic lagoons), anaerobic granules (upflow anaerobic sludge blanket – UASB), or biofilms on fixed support (anaerobic filter) or on mobile support as with the fluidized bed are in use. Some technologies include two strategies, e.g. a sludge bed with anaerobic filter as in the hybrid digester. With winery wastewaters (as for vinasses from distilleries), the removal yield for anaerobic digestion is very high, up to 90–95% COD removal. The organic loads are between 5 and 15 kg COD/m³ of digester/day. The biogas production is between 400 and 600 l/kg COD removed with 60–70% methane content. For anaerobic and aerobic post-treatment of vinasses in the Cognac region, the REVICO company has 99.7% COD removal and the cost is 0.52 Euro/m³ of vinasses (Moletta, 2005).

The long start-up period of fluidized bed biofilm reactors is a serious obstacle for their wide installation in the anaerobic treatment of industrial wastewater. A study presented the results of an anaerobic inverse turbulent bioreactor treating distillery wastewater during 117 days of operation on a laboratory scale. The precolonized bioparticles

Table 7.5 Estimates of the kinetics parameters of Graef and Andrews (1974) and Masse and Droste (2000)

Model	Parameter	Meaning	Value
Graef and Andrews (1974)	$\mu_{1\max}$	Maximum acidogenic biomass growth rate	1.2/day
	K_{S1}	Half-saturation constant associated with S_1	7.1g/l
	$\mu_{2\max}$	Maximum methanogenic biomass growth rate	0.74/day ¹
	K_{S2}	Half-saturated constant associated with S_2	9.28 mmol/l
	K_{I2}	Inhibition constant associated with S_2	256 mmol/l
	α	Proportion of dilution rate for bacteria	0.5 mmol/l
Masse and Droste (2000)	$K_L\alpha$	Liquid/gas transfer rate	19.8/day
	$\mu_{\max,a}$	Maximum growth rate of acid forming bacteria	450/day
	$\mu_{\max,pa}$	Maximum growth rate of acetogenic propionic bacteria	300/day
	$\mu_{\max,ba}$	Maximum growth rate of acetogenic butyric bacteria	264/day
	$\mu_{\max,m1}$	Maximal specific growth rates of acetoblastic bacteria	8.4/day
	$\mu_{\max,m2}$	Maximal specific growth rates of acetoblastic bacteria	20.1/day
	$\mu_{\max,H}$	Maximal specific growth rates of hydrogen utilizing bacteria	58.2/day
	k_c	Half-velocity constant for acid formers	100 mg/dm ³
	k_{pr}	Half-velocity constant for acetogenic propionic acid bacteria	700 mg/dm ³
	$k_{i,H1}$	Inhibition constants	0.1 mg/dm ³
	$k_{i,H2}$	Inhibition constants	0.5 mg/dm ³
	k_{AC}	Toxicity constants	0.05 mg/dm ³
	k_{VFA}	Toxicity constants	0.2 mg/dm ³
	k_{Bu}	Half-velocity constant for acetogenic butyric acid bacteria	64 mg/dm ³
	k_{m1}	Half-velocity constant for acetoclastic <i>Methanosaeta</i> bacteria	64 mg/dm ³
k_{m2}	Half-velocity constant for acetoclastic <i>Methanosaeta</i> bacteria	1280 mg/dm ³	
k_H	Henry's law constant	0.01 mg/dm ³	

for this work in particular were obtained from a similar reactor processing the same wastewater and which had a start-up period of 3 months. The system attained carbon removal efficiency rates between 70 and 92%, at an organic loading rate of 30.6 kg/m³/day (chemical oxygen demand) with a hydraulic retention time of 11.1 h. The results obtained showed that the start-up period of this kind of reactor can be reduced by using precolonized bioparticles (Arnaiz *et al.*, 2005).

An optimization method was implemented in an anaerobic digestion model to estimate its kinetic parameters and yield coefficients. This method combined the use of advanced state estimation schemes and powerful non-linear programming techniques to yield fast and accurate estimates of the aforementioned parameters. An asymptotic observer was first applied to provide estimates of the non-measured variables (such as biomass concentration) and good guesses for the initial conditions of the parameter estimation algorithm. These results were then used by the successive quadratic programming (SQP) technique to calculate the kinetic parameters and yield coefficients of the anaerobic digestion process. The model, provided with the estimated parameters, was

tested with experimental data from a pilot scale fixed reactor treating raw industrial wine distillery wastewater. It was shown that SQP reaches a rapid and accurate estimation of the kinetic parameters despite highly noise corrupted experimental data and time-varying inputs variables. A statistical analysis was also performed to validate the combined estimation method. Finally, a comparison between the proposed method and the traditional Marquardt technique revealed that both yield similar results, however, the calculation time of the traditional technique is considerable higher than that of the proposed method (Aceves-Lara *et al.*, 2005).

Thermophilic anaerobic digestion

The feeding material, vinasses, was transported, maintained at 4°C and diluted with tap water before their utilization. The parameters analyzed in both the effluent and the influents are pH, chemical oxygen demand (COD), both total and volatile suspended solids (TSS, VSS) and attached microbial mass (VS_{att}). For gaseous samples, the parameters analyzed are the volume of biogas produced at STP and their composition.

Performance and operation parameters during all stages of the experiment are given in Table 7.6 (OLR applied and OLR removal, organic COD removal efficiency, TSS, VSS and biogas and methane composition). The COD removal efficiency declined with decreased HRT (increased load) and was comparatively ineffective at HRT < 0.46 days (loading rates >32.3 kgCOD/m³/day).

Incineration

Considering the CO₂ and CO emissions (Table 7.7), the combustion efficiency was greater than 99.9%. Moreover, the macro-pollutant concentrations in the ash were also reported in Table 7.7.

Table 7.6 Parameters and experimental results of the thermophilic anaerobic digestion of winery waste

Time (days)	OLR ₀ (kgCOD/m ³ /day)	OLR _r (kgCOD/m ³ /day)	COD _r efficiency(%)	VSS (kg/m ³)	TSS (kg/m ³)	CH ₄ (m ³ /m ³ /day)	Biogas production (m ³ /m ³ /day)
0	6	6	93	0.55	0.7	0	0
23	6	6	95	0.15	0.26	1	0
45	9	9	97	0.15	0.27	2	2
58	12	12	96	0.25	0.4	3.5	5.5
63	17	16	95	0.25	0.3	5.5	9
74	27	26	93	0.25	0.3	8	11
78	27	26	90	0.45	0.5	8	15
84	28	27	89	0.6	0.6	8	17
88	33	26	81.5	0.65	0.7	8	16

Perez *et al.*, 2001; Vlissidis and Zouboulis, 1992)

The combustion efficiency of this incinerator, judging from the TOC measurements, is inversely proportional to the polychlorinated dibenzo-*p*-dioxins (PCDD) and polychlorinated dibenzofurans (PCDF) emissions. This is in agreement with the general behavior of incinerators (Metcalf and Eddy, 1991; Mariani *et al.*, 1992; Leckner and Lynfelt, 2002). The average PCDD and PCDF emission values from wine wastes, indicate that incineration can be used as an alternative disposal system, allowing energy recovery with high environmental impact.

Pyrolysis

The waste is charged in the basket and kept in the refrigeration zone of the reactor. Then, a gas flow of nitrogen is fed at 200 cm³/min and maintained for at least 1 h to remove air from any part of the installation. After this period, the heating system is connected and the run temperature is fixed to approximate a steady state situation. The basket goes through the heating zone of the reactor and the experiment starts. At that moment the experiment started and gaseous samples were withdrawn at regular intervals. Next, the heating is switched off and the basket moves back to the refrigeration zone. Finally, the weight of carbonaceous residue remaining in the basket and the amount of liquids obtained were measured when ambient temperature was reached. Later, solid, gas and liquid fractions were analyzed (42–44, 26.5–31.4 and 25.5–29.5 values obtained, respectively).

Table 7.8 shows the chemical composition of the char obtained from pyrolysis of wine wastes. Table 7.9 shows that an increase in temperature yields an increase in fixed carbon and ash. On the other hand, an increase in temperature results in a decrease in volatile matter.

Table 7.7 Macro-pollutant concentrations at the stack and in the ashes at cyclon and at the fabric filter

Parameters	Values
CO ₂	7.07%
CO	101.8 g/h
CO ₂ /CO + CO ₂	99.96%
Particulate	0.98 mg/Nm ³
HCl	3.78 mg/Nm ³
NO _x	305 mg/Nm ³
Pb	1.0 mg/Nm ³
VOC	0.95 mg/Nm ³
Heavy metals	8.8 mg/Nm ³
Cd	1.33–17.26 mg/kg
Pb	8.44–93.2 mg/kg
Hg	0.22–0.85 mg/kg
Cu soluble	0.80–1.12 mg/kg
Cu total	947–1088 mg/kg

Adapted from Mariani *et al.*, 1992

Table 7.8 Elemental analysis of char from wine waste

Parameter	Values obtained
C	63.9–71.3 wt%
H	2.62–3.96 wt%
N	2.05–2.72 wt%
O	16–16.53 wt%
S	0.7–0.11 wt%
HHV	21.8–23.83 MJ/kg

Encinar *et al.*, 1996, 1997; Blasi *et al.*, 1999

Table 7.9 The average percentages (wt%) of fixed carbon, volatile matter, ash for the char and the average production of gas (H₂, CH₄, CO, CO₂) as mole/kg waste obtained from the pyrolysis of winery wastes

Temperature (°C)	Fixed carbon (wt%)	Volatile matter (wt%)	Ash (wt%)	H ₂ (mol/kg)	CH ₄ (mol/kg)	CO (mol/kg)	CO ₂ (mol/kg)
300	33	59	8	0	0	0.1	0.8
400	55	35	11	0.1	0.1	0.8	2.1
500	62	22	14	0.2	0.22	1.1	3
600	67	18	16.5	1	0.77	1.4	2.2
700	71	13	17	3.4	1.22	2	1.8
800	72	11	17	–	–	–	–
900	75	8	17	–	–	–	–

Encinar *et al.*, 1996, 1997; Blasi *et al.*, 1999

Furthermore, the increase in temperature led to increase in hydrogen, methane and carbon monoxide production and to decrease in that of carbon dioxide. From an energy point of view, the solid and gas phases are the most suitable to benefit from this technique. The liquid phase, once problems of separation are overcome, can be used to obtain some high-value compounds. The energy value of gases is based on their heating power, which increases with the increasing temperature as a consequence of the high gas yield and hydrogen production (Encinar *et al.*, 1997). However, the energy value of the solid phase is clearly based on the charcoal obtained. Figure 7.3 shows the heating value of charcoals obtained from pyrolysis of wine wastes.

Ozonation

Table 7.10 shows the percentage degradation values obtained for phenolic acids at two reaction times (20 and 40 min) in experiments performed at pH 7 and 20°C with ozone and combined ozone-UV radiation.

The efficiency of ozone as a pre- and post-treatment to up flow anaerobic sludge-blanket (UASB) treatment was investigated, followed by a study into UASB reactor

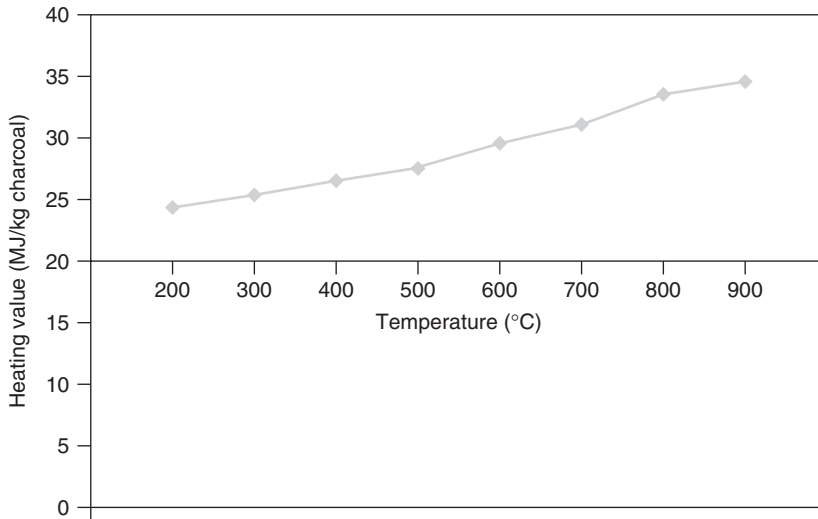

Figure 7.3 Heating value of charcoal obtained from pyrolysis of wine wastes

Table 7.10 Percentage degradation values obtained with application of ozone and ozone-UV radiation

Reaction times	% degradation obtained with application of ozone %	% degradation obtained with application of ozone-UV radiation %
20 min	69–76.3	75.3–88.8
40 min	93.1–98.9	98.5–100

Adapted from Blasi *et al.*, 1999

performance with ozonated wastewater as substrate. Combinations of pre- and/or post-ozonation with UASB treatment gave better results than ozonation or UASB alone and COD reductions of 53.0–98.39% were achieved for treatment of canning and winery wastewaters. A UASB reactor was fed with pre-ozonated cannery wastewater for over 70 days. COD removal improved from between 58.8 and 64.4% to between 85.3 and 91.8% after pre-ozonated substrate feed commenced. Subsequent increase in organic loading rate (ORL) from 2.4 to 3.4 kg COD/m³/day did not affect reactor performance. By including a final post-ozonation treatment to this UASB effluent, a total COD reduction of 99.2% was achieved (Sigge *et al.*, 2005).

Wet oxidation

As reported by Mantzavinos *et al.* (1996), special attention was given to the liquid sampling procedure to inhibit contamination of the samples and losses of the liquid phase. Table 7.11 shows the TOC and *p*-coumaric acid concentration reduction versus

Table 7.11 TOC reduction and concentration profile of *p*-coumaric acid at 130°C during the wet oxidation process

Time (min)	TOC reduction (ppm)	<i>p</i> -coumaric acid concentration (ppm)
0	480	740
10	480	700
20	480	620
30	475	590
40	470	460
50	470	300
120	450	120
170	442	80
220	400	50

Adapted from Mantzavinos *et al.*, 1996

time during the wet oxidation process at 130°C. It is evident that the TOC reduction remains relatively constant over the first minutes and decreases slightly in the course of time. However, in the case of concentration profile of *p*-coumaric acid, it decreases during the wet oxidation process, thus confirming the rapid conversion of *p*-coumaric acid to intermediate compounds.

In the case of catalyzed experiments, four different homogeneous and four heterogeneous catalysts were used for oxidation of *p*-coumaric acid. These catalysts were compared with respect to their impact on the oxidation routes and their activity for oxidation of *p*-coumaric acid. The homogeneous systems were:

- 1 Fe²⁺ as (NH₄)₂SO₄·FeSO₄·6H₂O
- 2 Cu²⁺ as Cu(NO₃)₂·3H₂O
- 3 Zn²⁺ as Zn(NO₃)₂·6H₂O
- 4 Co²⁺ as Co(NO₃)₂·6H₂O.

The heterogeneous systems were:

- 1 Fe oxide as FeO(OH)
- 2 a typical copper/zinc/alumina catalyst, as used for methanol synthesis
- 3 CuO.ZnO.CoO supported on Al₂O₃
- 4 Co/Bi composite oxide (Co/Bi:5/1 molar ratio) prepared by co-precipitation of the corresponding nitrate salts.

The heterogeneous catalysts, with particle sizes ranging between 38 and 106 μm, were introduced into the *p*-coumaric acid solution so that the resulting proportion was 0.4 m² (catalyst surface)/m³ (liquid volume). Table 7.12 revealed the TOC decrease during the wet oxidation of *p*-coumaric acid in the presence of homogeneous or heterogeneous catalysts, respectively.

As can be seen, from Table 7.12, the use of catalysts (heterogeneous or homogeneous) increased the decomposition rate of *p*-coumaric acid compared to the uncatalyzed

Table 7.12 TOC decrease during the oxidation of *p*-coumaric acid at 30°C in the presence of various homogeneous (pH = 1, concentration of homogeneous catalysts = 100 ppm) and heterogeneous (pH = 3 and 0.4 m²/mm³ surface area of heterogeneous catalysts) catalysts

Time (min)	Catalyst absence	Homogeneous catalysts				Heterogeneous catalysts			
		Fe ²⁺	Cu ²⁺	Zn ²⁺	Co ²⁺	Fe oxide as FeO(OH)	Copper/zinc/alumina typical catalyst	CuO.ZnO.CoO supported on Al ₂ O ₃	Co/Bi oxide
0	480	500	500	500	500	500	500	500	500
10	480	280	480	300	320	300	290	200	140
15	480	280	460	300	320	250	270	180	140
30	475	270	450	300	320	250	260	160	140

Adapted from Mantzavinos *et al.*, 1996

experiments. Of the homogeneous catalysts, Co²⁺ and Zn²⁺ ions were the most effective for *p*-coumaric acid wet oxidation, while the Fe²⁺ ion displayed the lowest oxidation activity. The addition of Cu²⁺ ion presented 90% decomposition of *p*-coumaric acid after 30 minutes of wet oxidation.

In the case of heterogeneous catalysts, Co/Bi composite oxide was the most effective for *p*-coumaric acid wet oxidation, while Fe oxide resulted in significantly lower oxidation rates. CuO.ZnO.CoO and CuO.ZnO catalysts presented comparable activity to the Co/Bi oxide. Comparisons between homogeneous and heterogeneous catalysts lead to the conclusion that homogeneous catalysts were more effective than heterogeneous catalysts. On the other hand, heterogeneous catalysts are better than homogeneous in the case of promoting wet oxidation under mild conditions and are more easily removed from the oxidized effluent prior to any subsequent biological treatment.

Main applications/constituents to be exploited

Polyphenol content

The phenolic compounds of wine, and particularly the flavanols (e.g. catechins, proanthocyanidins), have been the center of attention of recent studies since their relation to the beneficial effects attributed to a moderate consumption of wine was observed (Renaud and De Lorgeril, 1992; Shrikhande, 2000). These compounds have their origin in grapes and only a part of them is transferred to the must. Their extractability mainly depends on the technological conditions employed during vinification (Kammerer *et al.*, 2004). For this reason, important quantities of phenolic compounds still remain in the wine by-products and there is great interest in the exploitation of this type of grape by-product to

Table 7.13 Number of grape based by-products of health relevance in the USA

Grape seed	22
Grape extract	5
Red wine powder	7

Adapted from Shrikhande, 2000

obtain potentially bioactive phenolic compounds (Santos-Buelga and Scalbert, 2000; Moure *et al.*, 2001; Ray *et al.*, 2001).

The 'French paradox' initiated numerous studies focusing on the antioxidative and health-promoting effects of plant secondary metabolites in grapes and wine and revealing the inhibition of human low density lipoprotein (LDL) oxidation by grape and wine phenolics (Frankel *et al.*, 1995; Teissedre *et al.*, 1996; Kammerer *et al.*, 2004). Furthermore, free radicals have been implicated in over a hundred diseases in humans, including arthritis, atherosclerosis, advancing age, Alzheimer's and Parkinson's diseases, gastrointestinal dysfunctions, tumor promotion and carcinogenesis and AIDS among others. Antioxidants are potent scavengers of free radicals and serve as inhibitors of neoplastic processes (Alonso *et al.*, 2002). Moreover, antioxidants have an intense anti-inflammatory activity (Miyake *et al.*, 1999).

Natural flavonoids can donate hydrogen to and/or react with superoxide anions, hydroxyl radicals and lipid peroxy radicals, all of which can cause lipid oxidation *in vitro*, leading to LDL oxidation implicated in the development of atherosclerosis (Shrikhande, 2000).

It is noteworthy that winery residues could be an alternative source for obtaining natural antioxidants that are considered completely safe in comparison with synthetic antioxidants such as butylated-hydroxyanisole (BHA) and butylated-hydroxytoluene (BHT), compounds now largely used in the food industry with undesirable effects on the enzymes of human organs (Nakatani, 1997).

Because of these beneficial properties, winery by-products are now being sold to the rapidly growing dietary supplement industry. Table 7.13 provides an idea of the various grape based products of different origin currently available in the US market and shows that grape seeds are the most popular by-products of winery wastes in the most representative market of the world. Grape seed oil is derived from grape seeds that are left in abundance from the winemaking process. In a survey published in 1993, Nash and Nash (1993) showed that, in a sample group of 56 men and women consuming up to 43 g per day, an amount that one can cook with, grape seed oil had the ability to raise HDL levels by 13% and reduce LDL levels by 7% in three weeks. The total cholesterol/HDL ratio was reduced 15.6% and the total LDL/HDL ratio was reduced by 15.3%, which could be significant for those at risk of a heart attack.

Grape seed oil contains vitamin E (80–120 mg/100 g), vitamin C, beta-carotene, 0.8–1.5% unsaponifiables rich in tocopherols, steroids (campesterol, beta-sitosterol, and stigmasterol) and several fatty acids, which are reported in Table 7.14 (http://en.wikipedia.org/wiki/Grape_seed_oil).

Table 7.14 Average composition of grape seed oil fatty acids

Common name	Acid name	Average percentage range
Omega-6	Linoleic acid	69-78
Omega-9	Oleic acid	15-20
Palmitic acid	Hexadecanoic acid	5-11
Stearic acid	Octadecanoic acid	3-6
Omega-3	A-Linolenic acid	0.3-1
Palmitoleic acid	9-Hexadecenoic acid	0.5-0.7

http://en.wikipedia.org/wiki/Grape_seed_oil

Table 7.15 Quantity of total phenolic substances, total flavanoids and proanthocyanidins reported as g/l of grape extract and g/100 g dry matter in grape seeds

Total phenols (GAE)	Total flavanoids (CE)	Proanthocyanidins (CyE)
g/l 2.86 ± 0.01	g/l 2.79 ± 0.01	g/l 1.38 ± 0.06
g/100 g DM 8.58 ± 0.03	g/100 g DM 8.36 ± 0.04	g/100 g DM 5.95 ± 0.17

Adapted from Negro *et al.*, 2003. GAE: gallic acid equivalent, CE: catechin equivalent, CyE: cyanidin equivalent

Furthermore, it is noteworthy that grape seeds contain flavan-3-ols and its repeat unit including dimers, trimers, etc. and much larger polymers, perhaps with a degree of polymerization from 7 to 16 (Haslam, 1980). The structure of seed extract is very complex, but reverse phase high performance liquid chromatography (HPLC) provides separation of major groups such as monomers, procyanidin oligomers and polymers (Prieur *et al.*, 1994). Moreover, Aaby *et al.* (2004) reported that flavanoids are UV absorptive and have traditionally been analyzed by HPLC with UV/visible detectors.

However, concentration of phenols in commercial preparations is adequately represented by total phenols in the Folin-Ciocolteau procedure and expressed as gallic acid equivalent (Singleton and Rossi, 1965). The concentration of total phenolic substances, total flavanoids and their different classes is illustrated in Table 7.15.

As can be seen from Table 7.15 the quantity of total phenolic substances and total flavonoids contained in the grape seed extract was higher than that obtained from the peel and the marc as such. Moreover, Shrikhande (2000) reported that total phenol ranges from the mid 40s to mid 90s thereby indicating that higher numbers are the result of greater purification of phenols from other seed substances, possibly requiring multiple solvent extractions and precipitations. Such processes are expensive, less flexible and provide lower yields.

Gonzalez-Paramas *et al.* (2004), Alonso *et al.* (2002) and Negro *et al.* (2003) published specific studies regarding the antioxidant activity of winery wastes. A general diagram based on experimental data obtained by Gonzalez-Paramas *et al.* (2004) regarding to the antioxidant activity of grape seed extract (winery wastes) is shown in Figure 7.4. Figure 7.4 illustrates the antioxidant capacity of the extracts at different concentrations obtained

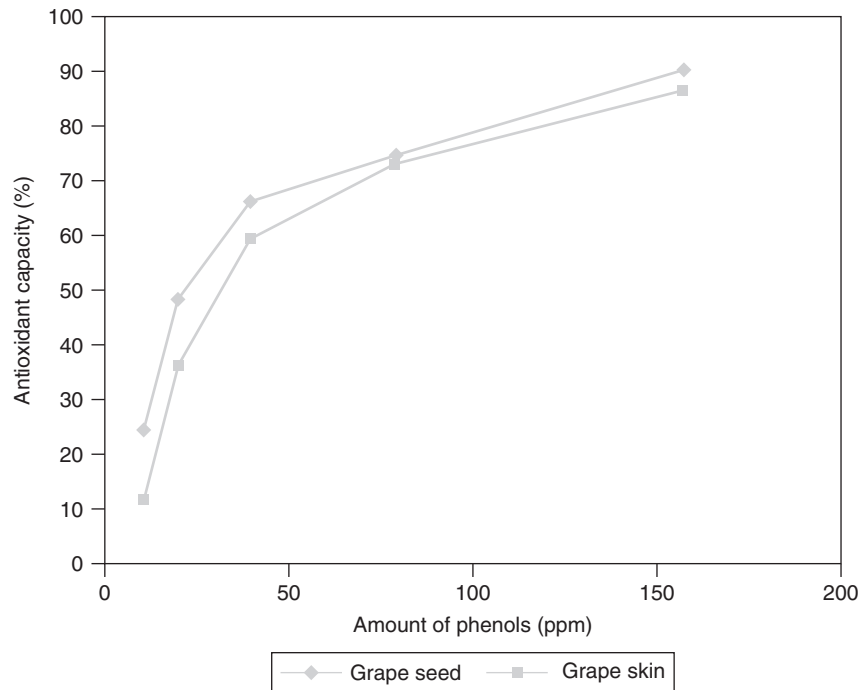

Figure 7.4 Antioxidant capacity (%) of the extracts from grape seeds and grape skin extracts (adapted from Alonso *et al.*, 2002; Negro *et al.*, 2003; Gonzalez-Paramas *et al.*, 2004)

from grape seed. All the extracts had an antioxidant capacity and this rose with an increase in concentration of phenolic substances until it reached the highest concentration determined (160 ppm) (Negro *et al.*, 2003).

Furthermore, it is noteworthy that grape seed extract is reputed to have antioxidant activity when fed to animals (Tebib *et al.*, 1997). Grape seed tannins or proanthocyanidins were shown to have a hypocholesterolemic, anti-atherosclerotic, and antioxidant effect *in vivo* when fed to rats receiving diets with cholesterol (Tebib *et al.*, 1994, 1997; Yamakoshi *et al.*, 1999). Moreover, addition of grape seed proanthocyanidins (GSPC) to a system containing polyunsaturated fatty acids and mice liver or brain microsomes inhibited oxidation by UV light peroxidation (Bouhamidi *et al.*, 1998).

Apart from grape seed extracts, the grape skin extracts are also being marketed due to their complex structure, consisting of anthocyanins and procyanidins (Shrikhande, 2000). Yamakoshi *et al.* (1999) suggested that procyanidins might react with reactive species in plasma and interstitial fluid of the arterial wall, thereby inhibiting oxidation of LDL and displaying an anti-atherosclerotic activity.

Anthocyanins are a group of phenolic compounds that belong to the flavanoid family. They are responsible for the coloration (orange, rose, red, violet and blue) of the petals of flowers and fruit of a great variety of plants (Strack and Wray, 1989). There are numerous sources of anthocyanins, but the main raw material is the pomace from the red wine vinification process (Francis, 1992). After the first isolation of enocyanin, dating from 1879, many authors have developed patents for the production of concentrated

Table 7.16 Anthocyanin content (mg/kg dry matter) of grape skins

Compound	Value (mg/kg dry matter)
Delphinidin 3-O-glucoside	68–5552
Cyanidin 3-O-glucoside	37–1903
Petunidin 3-O-glucoside	65–6680
Peonidin 3-O-glucoside	515–12450
Malvidin 3-O-glucoside	1117–50981
Delphinidin 3-O-acetglucoside	392–956
Petunidin 3-O-acetglucoside	545–1375
Peonidin 3-O-acetglucoside	1371–1484
Peonidin 3-O-acetglucoside	45–8688
Cyanidin 3-O-coumaroylglucoside	374–1071
Petunidin 3-O-coumaroylglucoside	974–2458
Peonidin 3-O-coumaroylglucoside	68–6828

Adapted from Kammerer *et al.*, 2004

aqueous solutions of anthocyanins for food use (Marakakis, 1982; Fuleki and Babjak, 1988). Nowadays, the European Union allows the use of the anthocyanins as food dyes in drinks, marmalades, candies, ice creams and pharmaceutical products (Council of EU, 1994). The contents of individual anthocyanins in the grape seeds from several varieties of *Vitis vinifera* are summarized in Table 7.15.

Table 7.16 shows that malvidin 3-O-glucoside is the predominant compound, mostly followed by peonidin 3-O-glucoside. On the other hand, delphinidin 3-O-acetglucoside and petunidin 3-O-acetglucoside are represented in lower values.

It is evident from Figure 7.5 that an increase in the amount of phenols led to an increase of the antioxidant capacity. Moreover, Negro *et al.* (2003) found by testing the grape skin extracts at 160 ppm that it is possible to obtain high antioxidant capacity ranging from 11.7% to 86.3%.

It can be concluded that wine and other products derived from the grape have a high antioxidant capability and, as consequence of this, they are endowed with potential health benefits. Both grape skins and seeds extracts are a valuable solution for the recovery of antioxidant compounds and a significant advance in maintaining the environmental equilibrium because, in grape and wine producing zones, large quantities of residues are generated and this presents problems of storage, conversion, or elimination, in both ecological and economic terms.

Revalorization of grape seed, a winery industry residue, was studied for the production of an oil and defatted meal with nutraceutical properties. The conventional grape seed oil extraction process is carried out by pressing at high temperature, affecting the product quality. Oil extraction by cold pressing improves product quality, but it gives a low oil yield. Oil extracted increased at the pressing stage, when an enzymatic pretreatment was incorporated into the conventional process. The yield is determined from the residual oil in the pressed cake. Using an enzymatic treatment for 9 h at 45°C and 50% of moisture, with a mixture of two commercial enzymes, grape seed oil extraction yield by cold pressing raised up to 72%, being a 59.4% increment in comparison to the yield

obtained by the control, without enzymes. The defatted meal, by an enzymatic assisted process, improves its phenolic compounds between 2 and 4 times, depending on the conditions of phenolics extraction in comparison to the control samples (Tobar *et al.*, 2005).

Compost fertilizer

The production of healthy, uniform plants is a basic requirement of modern greenhouse agriculture. Container media must be homogeneous, aerated, reproducible and pathogen-free. Growers, in an attempt to meet the need for a substrate with proper air and water capacity, use many types of organic and inorganic materials. Increasing demand and rising costs for peat, used as a substrate in horticulture, have led to a search for high quality and low cost composts derived from organic wastes such as winery wastes (Inbar *et al.*, 1986, 1988).

The effort to increase agricultural income may come from the expansion of integrated production systems and organic farming. This approach will provide certified agricultural products, which will be both beneficial to consumer's health and attract higher financial premiums. However, this requires the gradual replacement of chemical fertilizers, currently extensively used in agriculture production, with organic soil amendments (Bazzoffi *et al.*, 1998; Navas *et al.*, 1998; Edwards *et al.*, 2000; Querejeta *et al.*, 2001).

The use of compost, derived from winery wastes, in vineyards is of growing interest due to the general poverty of soils, typified by low levels of humus and their exposure to erosion (Balanya *et al.*, 1994). Graefe (1980) proposed the use of composted winery wastes as a high-grade organic fertilizer, while recovering heat and CO₂ produced during the composting process. The application of compost from winery wastes increased the percentages of organic matter, nutrient levels (providing a slow fertilization action over a long period of time), microbial biomass and improves the soil's physical properties (aeration, water-holding capacity, etc.) (Riberea-Gayon and Peybaud, 1982).

Moreover, grape waste was subjected to composting studies in several countries: France (Faure and Deschamps, 1990; Faure, 1991), Germany (Dittmer *et al.*, 1990), Spain (Costa *et al.*, 1989; Garcia *et al.*, 1990, 1992), Yugoslavia (Stojanovic *et al.*, 1989), Israel (Mandelbaum *et al.*, 1988) and Venezuela (Ferrer *et al.*, 1993; Sanchez and Ferrer, 1994).

Regarding combinations of winery wastes with other materials, Ingelmo *et al.* (1998) investigated the feasibility of using composted municipal solid wastes (MSW), sewage sludge and other organic wastes to produce alternative substrates for ornamental plants and to improve the re-vegetation of a closed landfill with satisfactory results. Ferrer *et al.* (2001) reported the combinations of recently compressed grape waste and hen droppings used as an organic fertilizer for 20-day corn. All the treatments in the 20-day corn experiment with winery wastes were superior to that with a chemical industrial fertilizer composed of urea, K₂O and P₂O₅, 0.45 g dry matter/pot. This superiority was due to the presence of other minerals and micronutrients in the composted organic fertilizer, which contributed to a better development of the corn plant, as well as to humic compounds that provide the porous capacity to the soil (Ferrer *et al.*, 1993; Sanchez

and Ferrer, 1994; Sastre *et al.*, 1996). Finally, Ferrer *et al.* (2001) recommended that 3000 kg/ha of grape waste compost should be supplemented with phosphorus.

In addition, Raviv *et al.* (1986) reported that combinations of sewage sludge and MSW compost with other residual materials, such as pine bark, grape marc or rice hull, were worth investigation because negative properties of single materials, such as heterogeneity, high salinity, low content of organic matter, low cation exchange capacity or high content of contaminants can be minimized, thus obtaining a sound and inexpensive substrate (Ingelmo *et al.*, 1998).

The chemical composition of compost derived from winery waste is shown in Table 7.17. The physicochemical and chemical characteristics of compost derived from winery wastes are summarized in Table 7.18.

As can be seen from Tables 7.17 and 7.18, the compost derived from winery wastes is of good quality with satisfactory physicochemical characteristics and a sufficient amount of nutrients. Moreover, Lasaridi *et al.* (2000) reported that the compost derived from pressed grape skin produced one of the best quality composts both in

Table 7.17 Chemical composition of compost derived from winery waste

Element	Values
N	2.14–3.74%
P	0.18–0.52%
Ca	3.17–14.3%
Mg	0.3–0.61%
Fe	0.5 %
Zn	77–109 mg/kg
Cu	30–46 mg/kg
Ni	9.1–17.6 mg/kg
Cr	23.4–147 mg/kg
Pb	8–19 mg/kg
Cd	0.2–0.4 mg/kg

Table 7.18 Physicochemical and chemical characteristics of compost derived from winery wastes

Parameter	Values
pH	6.5–8.5
EC	1.57–4.1 MS/cm
Volatile solids	46.8–67.5%
C/N ratio	11.9–19.5
Moisture	47–66%
CEC	108.65 Cmol/kg
OM	84.15–89.1%
C	40.5–51.5%

terms of its physicochemical characteristics and agronomic value. The compost obtained is particularly recommended for application to the vineyards because:

- 1 the humified nature of the organic matter would facilitate its incorporation and improve the water holding capacity of the soil, an important factor for the quality and specificity of wine production
- 2 nitrogen is released only gradually, which is particularly appropriate for the vineyards that suffer from high nitrogen levels
- 3 it reports high to moderate values of potassium, considered a quality factor in wines (Ribereau-Gayon and Peybaud, 1982; Vez, 1993; Delas, 2000).

Manios (2004) investigated the potential use of pressed grape skins as a substrate component for the cultivation of strawberries. A mixture containing 25% (v/v) pressed grape skins compost and 75% (v/v) pumice was used and produced an average fruit yield of 306 g/plant and biomass yield of 97 g/plant. These results were the highest in comparison with other various organic residues derived composts and are shown in Table 7.19.

Furthermore, Ingelmo *et al.* (1998) reported the results regarding the final height of ornamental plant cultivation (*N. oleander*, *C. sempervirens* and *R. officinalis*) derived from using a mixture of 50% grape marc and 50% peat and a mixture of 50% grape marc, 25% sphagnum moss peat and 25% anaerobically-treated sewage sludge as a soil substrate. The duration of the experiment was 10 months and the results were summarized in Table 7.20.

In spite of its advantages, the application of agricultural wastes in soil can lead to problems because of their heavy metal content. The continuous application of waste enriched in heavy metals results in heavy metal accumulation in soil. Land disposal of organic waste materials may directly or indirectly alter the heavy metals status of the

Table 7.19 Fruits and biomass yield (wet weight) of strawberry plants growing in substrates containing different composts

Substrate composition	Fruits yield (g/plant)	Biomass yield (g/plant)
PGSC (25%) and pumice (75%)	306	97
OTLC (25%) and pumice (75%)	256	85

Adapted from Manios, 2004. PGSP: press grape skin compost; OTLC: olive tree leaves compost

Table 7.20 Results regarding substrate suitability and final height of three different plants

Substrate	<i>N. oleander</i>	<i>C. sempervirens</i>	<i>R. officinalis</i>
50% grape marc and 50% peat	32.8 cm	55.5 cm	41–42.2 cm
50% grape marc, 25% sphagnum moss peat and 25% anaerobically-treated sewage sludge	42 cm	59.6 cm	39.3–44.7 cm

Adapted from Kammerer *et al.*, 2004

soil by affecting metal solubility or dissociation kinetics (Del Castilho *et al.*, 1993; Karaka, 2004). In addition, Pinamonti *et al.* (1997) reported that the heavy metal content is a critical factor leading to restricted agricultural use of compost.

The presence of heavy metals is undesirable because it can cause adverse effects both to the environment and to a variety of living species including humans. Metals can be distinguished from other toxic pollutants, since they are not biodegradable and can be accumulated in living tissues, causing various diseases and disorders (Villaescusa *et al.*, 2004).

The total heavy metal content of the soil is commonly used to indicate the degree of contamination, but the heavy metal concentration in solution mostly determines the actual environmental exposure or risk. Distribution of heavy metals between soils and solute is the key to evaluating the environmental impact of the metals (Sposito, 1989; Karaka, 2004).

Karaka (2004) investigated the influence of grape marc on the DTPA extractable Cd, Cu, Ni and Zn in soil (typic xerofluvent). As a result of this investigation, Table 7.21 gives the concentrations of DTPA extractable Cd, Cu, Ni and Zn (mg/kg) in the soil at increasing rates of grape marc applied. As can be seen from Table 7.21, a significant negative correlation was found between extractable Cd, Cu, Ni and rate of applied grape marc. On the other hand, DTPA-extractable Zn increased with increasing rate of grape marc. It was finally concluded that the effect of organic waste application on the extractability of Cd, Cu, Ni and Zn in the soil depended on pH, organic matter content of the organic wastes, the metals studied and the time elapsed after their application.

Pullulan

Grape skin pulp is a by-product of the wine industry amounting to thousands of tonnes annually. In Greece, the average annual production of grape skin pulp for the years 1996–2000 was 14200 t (Arapoglou *et al.*, 2002). Hot water extracts of grape skin pulp can serve as a good substrate for the production of pullulan, an industrially important polysaccharide (Le Duy and Boa, 1982). Pullulan is an exocellular homopolysaccharide of economic importance produced by the yeast-like fungus *Aureobasidium pullulans*. It consists of maltotriose units linked through 1,6 glycosidic bonds (Saha and Zeikus, 1989).

Table 7.21 Concentrations of DTPA extractable Cd, Cu, Ni and Zn (mg/kg) in the soil at increasing rates of grape marc applied

Rate of applied grape marc (%)	Cd (mg/kg)	Cu (mg/kg)	Ni (mg/kg)	Zn (mg/kg)
0	0.054–0.057	2.10–2.20	2.50–2.90	1.20–1.50
2	0.040–0.043	1.80–1.90	1–1.10	1.90–2.30
4	0.039–0.041	1.60–1.70	0.80–0.90	2.10–2.40
8	0.027–0.031	1.76–2.10	0.65–0.83	2.70–2.90

Adapted from Karaka, 2004

Moreover, pullulan is used as a low-calorie ingredient in foods, as a viscosity imparting agent and binder and, because of its low oxygen permeability, as a packaging agent. It is used in the pharmaceutical industry as a bulking agent and binder and as an oxidation-prevention agent for tablets. Other applications include films and adhesives, microencapsulating agents for flavor and spices and as a water-solubility enhancer in fertilizers (Israilides *et al.*, 1998).

The industrial applications of pullulan have been thoroughly reviewed by Deshpande *et al.* (1992). The market price of food and pharmaceutical grade pullulan is about 88 Euros per kg and the current world supply (circa 1000 tonnes) is produced almost exclusively by the Japanese company Hayashibara Co. Ltd., Okayama, Japan (Arapoglou *et al.*, 2002).

Pullulan is usually recovered from the fermentation broth by ethanol or methanol precipitation after the removal of cells. It has been shown, however, that the purity of pullulan in the ethanol-precipitated substances may vary according to the substrate used for the fermentation (Israilides *et al.*, 1994). The determination of pullulan in mixtures is usually carried out by hydrolysis with pullulanase followed by estimation of the resulting maltotriose with chromatography, radiometry or other methods (Catley, 1972; Finkelman and Vardanis, 1982).

Arapoglou *et al.* (2002) and Israilides *et al.* (1998) investigated the solid-state fermentation of grape skin pulp extracts by *Aureobasidium pullulans* with the aim to obtain pullulan. Figure 7.5 shows the biomass and ethanol-precipitated substances

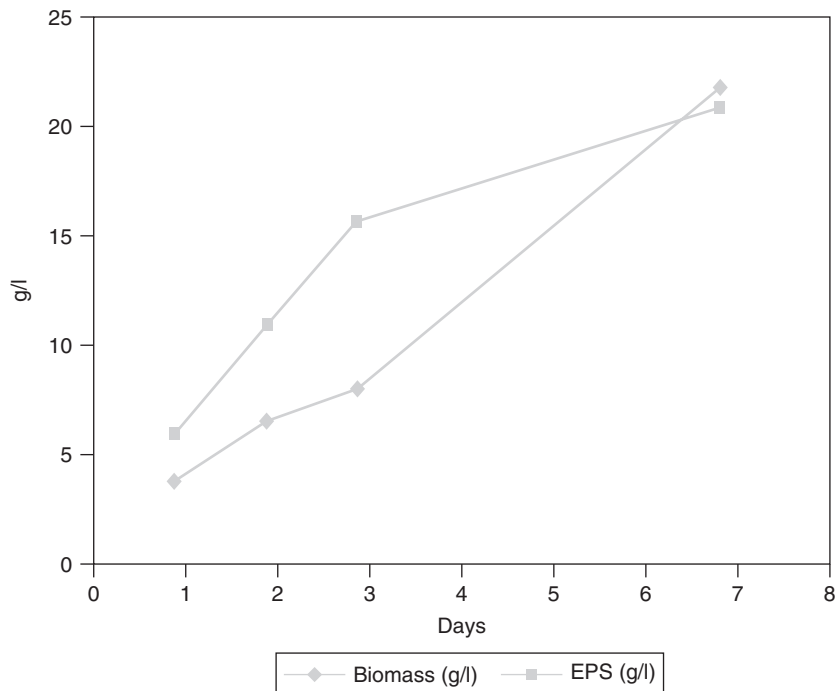

Figure 7.5 The biomass and ethanol-precipitates substances (EPS) as a function of fermentation time using grape skin pulp extracts (adapted from Israilides *et al.*, 1994; Arapoglou *et al.*, 2002)

(EPS) as a function of fermentation time using grape skin pulp extracts. From Figure 7.6, it is evident that the biomass and ethanol-precipitated substances (EPS) increased with the increase in fermentation days. The abovementioned parameters reached their highest values on the seventh day of fermentation.

Table 7.22 gives the pullulan content of EPS as estimated by coupled-enzyme assay and by high-pressure anion-exchange chromatography pulsed amperometric detection (HPAEC-PAD) for grape skin pulp extracts supplemented with NH_4NO_3 and K_2HPO_3 after seven days of fermentation. In this Table, pullulan was expressed as a percentage of the ethanol-precipitated substances (EPS) (Israilides *et al.*, 1998). Israilides *et al.* (1998) also reported that the grape skin pulp extracts were the richest in pullulan (97.4%) in comparison with other materials.

In conclusion, it can be said that the grape skin pulp can be recycled and used as a substrate for the production of a high added value product, effectively pullulan, a polysaccharide with many industrial uses and applications.

Adsorbent

Effluent industrial wastewater containing heavy metals usually causes serious problems. Because of the toxicity and assimilation of heavy metal to organisms, safe and effective treatment of heavy-metal-containing wastewater becomes a challenging task for industry due, in part, to the fact that cost-effective methods are not available (Sistrava *et al.*, 1997; Yuan-shen *et al.*, 2004). Conventional methods for removing metals from industrial effluents include chemical precipitation, coagulation, solvent extraction, electrolysis, membrane separation, ion exchange and adsorption (Patterson, 1997).

The high capital and regeneration costs of activated carbon and different types of ion exchange resins, materials which were often used in adsorption processes, limit their large-scale use for the removal of heavy metals (Kratochvil and Volesky, 1998; Bailey *et al.*, 1999; Villaescusa *et al.*, 2004). The presence of complex ligands in industrial wastewater can hinder metal hydroxide precipitation and may result in

Table 7.22 Pullulan content of EPS as estimated by coupled-enzyme assay and by high-pressure anion-exchange chromatography pulsed amperometric detection (HPAEC-PAD) for grape skin pulp extracts

Substrate	Concentration of EPS (%w/v)	Coupled enzyme assay				Pullulan % dry matter	Pullulan (HPAEC-PAD) by (%w/w)
		A ($\Delta\text{A}/\text{min}$)	B ($\Delta\text{A}/\text{min}$)	A - B ($\Delta\text{A}/\text{min}$)	A/B		
Grape skin pulp extract	0.25	0.1084	0.001	0.1074	108	97.4	128.5

Adapted from Israilides *et al.*, 1998

residual metal concentration, so that meeting the increasing stringent effluent regulations may be difficult (Weng, 2002).

For these reasons, absorption as an alternative method was shown to be effective for removing heavy metals from industrial wastewater. Several natural and synthetic hydrous solids have been investigated as absorbents of heavy metals (Yuan-shen *et al.*, 2004). Among these, waste products from agricultural operations, like winery wastes, were considered as low cost sorbents in the removal of toxic heavy metals. These sorbents have several advantages compared to others including that they are inexpensive and these materials that are considered as waste products can be reused for effluent decontamination. In addition, these sorbents appear to have an application as preconcentration agents (Villaescusa *et al.*, 2004). The potential of winery wastes as an adsorbent to remove chromium, nickel and copper from aqueous solutions was investigated (Villaescusa *et al.*, 2004). The sorption of metals by winery wastes might be attributed to their proteins, carbohydrates and phenolics, compounds that have carboxyl, hydroxyl, sulfate, phosphate and amino groups that can bind metal ions.

In order to evaluate the usage of winery wastes as an adsorbent, these wastes were washed with deionized water and dried in an oven at 105–110°C. Then they were cut, sieved into several particle sizes and desiccated. Metal solutions were prepared by dissolving appropriate amounts of $\text{CuCl}_2 \cdot 2\text{H}_2\text{O}_{(s)}$, $\text{NiCl}_2 \cdot 2\text{H}_2\text{O}_{(s)}$ and $\text{Cr}(\text{NO}_3)_3$ in distilled water. Finally, batch adsorption experiments were performed to determine the adsorption characteristics of Cu, Cr and Ni on the winery wastes. In this case, isotherm adsorption tests were conducted in a series of glass tubes, filled with Cu, Cr and Ni ion solutions of varying concentrations and adjusted to the desired temperature and pH with either HCl- H_2SO_4 or NaOH solution (Villaescusa *et al.*, 2004; Yuan-shen *et al.*, 2004).

Furthermore, it is noteworthy that Langmuir isotherms were used to describe sorption data. Langmuir isotherms have been useful tools for the description and comparison of heavy metal sorption by different sorbents (Chong and Volesky, 1995; Kaewsarn, 1998). Particular details about Langmuir isotherms were reported by Villaescusa *et al.* (2004) and Yuan-shen *et al.* (2004).

Figure 7.6 displayed the Cu, Cr and Ni removal using winery wastes as a function of pH. Particularly, the pH of metal solutions was identified as the most important variable sorption on hydrous solids. This is partly due to the fact that the hydrogen ions themselves are strong competing sorbates and partly that the solution pH influenced the chemical speciation of metals ion (Kratochvil and Volesky, 1998; Villaescusa *et al.*, 2004).

As can be seen from Figure 7.6, the removal for all metals increased with increase in pH value. In particular, the uptake increased from practically zero at equilibrium pH 1.0 to 78–80% at pH 5.5 for all metals. The absence of sorption at low pH values can be explained by the fact that, at these pH values, the H^+ concentration is high, which can compete with Cu, Cr and Ni cations for surface sites (Villaescusa *et al.*, 2004). The results showed that winery wastes can be used as an adsorbent for the effective decontamination of metal-containing effluents.

A waste sludge produced from a wine processing wastewater treatment process was used as an adsorbent to remove lead (II) from aqueous solution. Results of kinetic

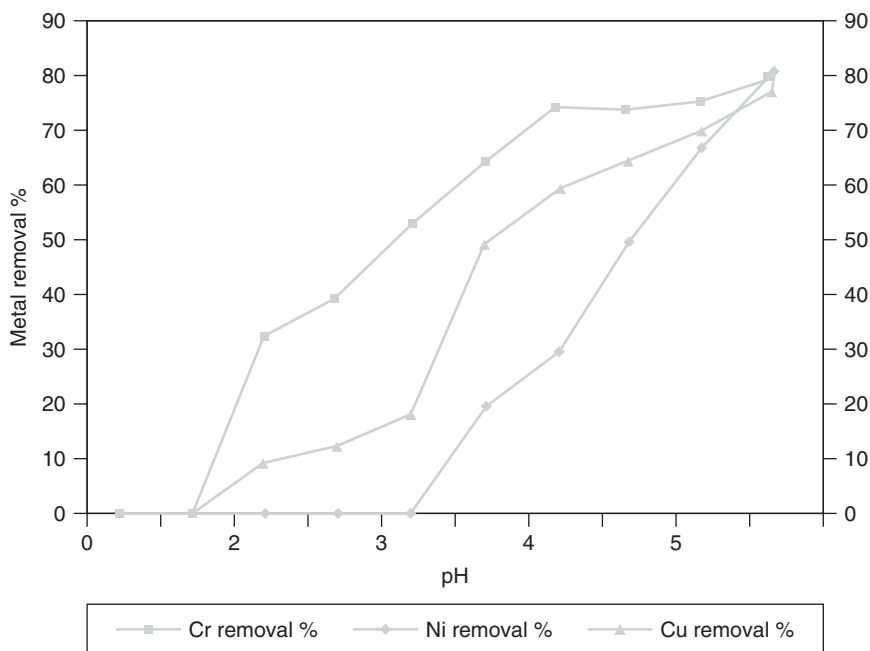

Figure 7.6 Cu, Cr and Ni removal % using winery wastes as a function of equilibrium pH (adapted from Yuan-shen *et al.*, 2004; Villaescusa *et al.*, 2004)

experiments demonstrated that the adsorption was effective and rapid. Four different kinds of adsorption kinetic models (i.e. pseudo, first-order and two intraparticle mass diffusion models) were used to investigate the adsorption mechanisms. A normalized standard deviation was used to find the best adsorption kinetic model for the removal of lead (II) by the sludge. The comparison revealed that the kinetic adsorption data can be well described by the pseudo-second-order adsorption model and that sorption might be a rate-limiting control. The adsorption-rate constant and adsorption capacity of the pseudo-second-order adsorption equation were calculated. The parameters (initial lead (II) concentration, sludge particle size and sludge dosages) which affect the adsorption capacity of sludge were discussed by using the pseudo-second-order adsorption equation (Li *et al.*, 2006).

Cr(VI) sorption on 2% grape stalks encapsulated in calcium alginate beads was examined in a continuous packed bed column. The effect of operating parameters as flow rate, inlet metal ions concentration and bed height on the sorption characteristics was investigated. The total amount of metal sorbed, equilibrium uptake and total removal percent of Cr(VI) related to the effluent volumes were determined by evaluating the breakthrough curves obtained at different flow rates and different inlet chromium (VI) concentration. Results indicated that Cr(VI) uptake by 2% GS-CA beads takes place through a complex mechanism, where the sorption process is controlled by mass transfer and intraparticle diffusion. The polymeric matrix had a low contribution to metal adsorption by 2% GS-CA beads. The proposed adsorption model gave good agreement between theoretical and experimental breakthrough profiles. Further model

adjustments are needed in order to avoid model deviation at high operation time values. The effective diffusion and mass transfer coefficients for Cr(VI) removal were estimated by the model equations. The BDST model, that does not consider metal diffusion on beads, failed to predict the service time at the experimental operating conditions used (Fiol *et al.*, 2006).

Grape bagasse generated in the wine production process was characterized by X-ray diffractometry, Fourier transform infrared spectroscopy, nuclear magnetic resonance and thermogravimetric analysis. The efficiency of this natural material for Cd(II) and Pb(II) adsorption was evaluated using a batch adsorption technique. Factors affecting metal adsorption, such as pH and contact time, were investigated. Maximum adsorption was found to occur at pH 7.0 and 3.0 for Cd(II) and Pb(II), respectively, and a contact time of 5 min was required to reach equilibrium for both metals. Under these conditions, adsorption studies were performed using a single solution. In addition, the adsorption capacities were found to be 0.479 and 0.204 mmol/g for Cd(II) and Pb(II), respectively. The results showed that grape bagasse could be employed as a low cost alternative adsorbent for effluent treatment (Farinella *et al.*, 2007).

The sorption of lead and cadmium from aqueous solution by grape stalk waste (a by-product of wine production) was investigated. The effects of the contact time, pH of solution, ionic medium, initial metal concentration, other metal ions present and lignands were studied in batch experiments at 20°C. Maximum sorption for both metals was found to occur at an initial pH of around 5.5. The equilibrium process was described well by the Langmuir isotherm model, with maximum grape stalk sorption capacities of 0.241 and 0.248 mmol/g for Pb(II) and Cd(II), respectively, at pH around 5.5. Kinetic studies revealed good correlation coefficients for a pseudo-second-order kinetic model. The presence of NaCl and NaClO₄ in the solution caused a reduction in Pb and Cd sorption, the latter being more strongly suppressed. The presence of other metals in the uptake process did not affect the removal of Pb, while the Cd uptake was much reduced. HCl or EDTA solutions were able to desorb lead from the grape stalk completely, while an approximately 65% desorption yield was obtained for cadmium. From the results obtained it appears that other mechanisms, such as surface complexation and electrostatic interactions, must be involved in the metal sorption in addition to ion exchange (Martinez *et al.*, 2006).

Grape pomace, the main polluting waste from the wine industry, is a good natural medium for solid-state fermentation (SSF). Its chemical composition is rich in the main nutrients required for growth of a wide range of microorganisms. The low cost of this material makes it potentially promising for such applications. Botella *et al.* (2005) studied the growth behavior of *Aspergillus awamori* on grape pomace as the sole nutrient source for producing xylanase, cellulase and exo-polygalacturonase. A rapid rise in the activity of these enzymes was observed in the early stages of incubation (within the first 24 h). Xylanase and exo-polygalacturonase activities were high compared with corresponding values in the literature, showing good future prospects for industrial applications. Cellulase activity is inhibited. Endo-polygalacturonase shows a catabolic repression when the reducing sugar concentration in the medium is high (during the first few hours) and its activity increased when the reducing sugars decreased (Figure 7.7).

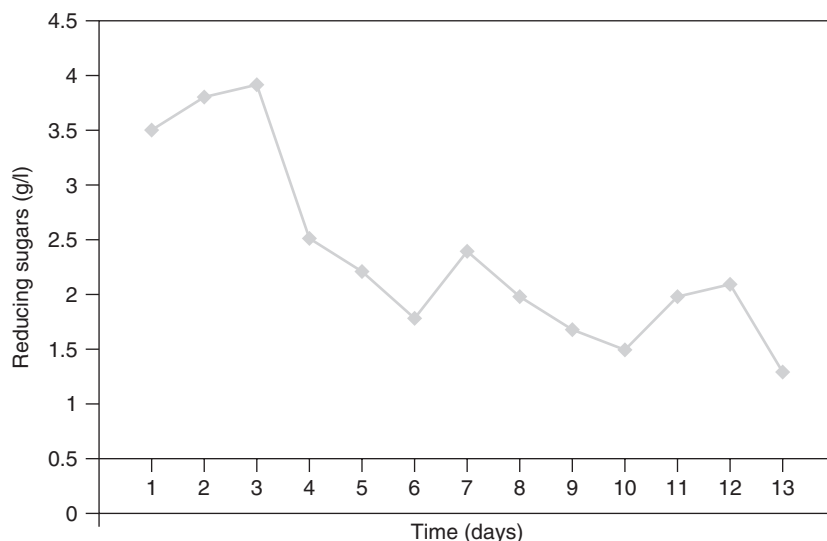

Figure 7.7 Glucose consumption, measured as reducing sugars in solid-state fermentation of *Phanerochaete chrysosporium*, *Trametes hirsuta*, *Lactobacillus* spp., *Aerobasidium pullulans* and *Pleurotus* spp. on winery wastes (adapted from Sanchez *et al.*, 2002; Couto *et al.*, 2003; Bustos *et al.*, 2004)

Taking account of the high specificity of the organic load of winery effluent, a new biophysical treatment using the stripping of ethanol combined with a final concentration by evaporation has been studied. Two options were proposed; full treatment and pretreatment. The study of the composition of winery wastewater showed the large, dominant part of ethanol in the organic load (75 to 99% of the COD). A linear correlation between COD and ethanol concentration can be used to estimate the organic load of winery wastewater. Full treatment by stripping and concentration at a pilot plant allows the separation of the wastewater into highly purified water (COD elimination >99%), a concentrated alcoholic solution usable as bio-fuel and a concentrated by-product. Stripping alone represents an advantageous pretreatment of winery wastewater. The purification rate reached 78–85% and ethanol was recovered. The process facilitated discharge into a sewage system in view of treatment with domestic effluents and can also improve the efficiency of overloaded or old purification plants. The economical approach of this method demonstrates its competitiveness in comparison with biological treatments: low energy consumed, no sludge (Colin *et al.*, 2005).

Wine processing waste sludge was shown to be an effective adsorbent for the adsorption of Cr(III) from aqueous solution. The sludge was characterized by scanning electron microscopy (SEM) and energy dispersive X-rays (EDX). The effect of pH, initial concentration of Cr(III), sludge particle size and temperature on the adsorption was studied. The equilibrium data could be described well with the Langmuir and Freundlich isotherm equations. A separation factor was used to judge the favorable adsorption. The calculated thermodynamic parameters, ΔH^0 and ΔS^0 , were 1.95 kJ/mol and 27.16 J/molK, respectively. The ΔG^0 values range from -5.98 to -6.79 J/mol, which

shows the physical adsorption properties of the sludge. Adsorption dynamics have been successfully studied by the Lagergren model and an intraparticle diffusion model (Li *et al.*, 2004).

The influence of the organic wastes derived from the winery and distillery industry (grape stalk (GS), grape marc (GM), wine lees (WL) and exhausted grape marc (EG)) and the soil type (clayey-loam (S1), loam (S2) and sandy texture (S3)) on different soil characteristics, especially the carbon and nitrogen mineralization was studied by Bustamante *et al.* (2006). The evolution of carbon mineralization fitted a first-order kinetic for all amended soils. An initial increase was observed in the specific respiration ($q\text{CO}_2$) at the beginning of the experiment. However, afterwards, the evolution in the $q\text{CO}_2$ tended towards the values of the control soil due to the pattern of the soil to recover its initial equilibrium status. The addition of these materials in the soils produced a slight increase in the inorganic nitrogen content, except in the case of GS and EG, in most of the studied soils. The use of GS as amendment produced an inhibition in the N mineralization in the three types of soils studied. Organic matter mineralization was probably influenced by soil type, the sandy soil favoring the N and C mineralization processes more than the clayey-loam and loam soils. For the obtained data, it can be concluded that the addition of these wastes to the soils did not modify the pH values due to the calcareous character of the used soils. However, the soil salinity increased in most of the amended soils and this could be the major concern regarding the use of the studied dose of winery and distillery wastes (96 t/ha, dry weight). The organic carbon mineralization was influenced by the soil characteristics and residue type. This mineralization increased when the clay content was lower in the soil and higher in the presence of soluble compounds in the residues. The residue type had a major effect on the N mineralization in the soil characteristics, observing that the polyphenol and the initial N and soluble compound contents, as well as the C:N ratio of the residue, were the most important influencing factors on the N soil dynamics. A low N mineralization of these materials was observed, especially in the soils amended with GS. Although these wastes did not show high fertilizing capacity, their use to protect the soil and conserve the organic carbon could be possibly due to carbon mineralization and $q\text{CO}_2$ evolution following the same pattern as other wastes usually used as soil amendments, GS being the only one not recommended due to its high N immobilization capacity.

References

- Aaby, K., Hvattum, E. and Skrede, G. (2004). Analysis of flavonoids and other phenolic compounds using high-performance liquid chromatography with coulometric array detection: relationship to antioxidant activity. *J Agric Food Chem* **52**, 4595–4603.
- Abad, M. (1991). Los sustratos horticolas: Características y manejo. In *Actas H Congreso Nacional de Fertirrigacion*, pp. 1–5. Fundacion para la Investigacion Agraria, Almeria.
- Aceves-Lara, C.A., Aquilar-Garnica, E., Alcaraz-Gonzalez, V. *et al.* (2005). Kinetic parameters estimation in an anaerobic digestion process using successive quadratic programming. *Water Sci Technol* **52**(1–2), 419–426.

- Alonso, A., Guilleán, D., Barroso, C., Puertas, B. and García, A. (2002). Determination of antioxidant activity of wine byproducts and its correlation with polyphenolic content. *J Agric Food Chem* **50**, 5832–5836.
- Andrés, L., Riera, F. and Álvarez, R. (1997). Recovery and concentration by electro dialysis of tartaric acid from fruit juice industries waste waters. *J Chem Technol Biotechnol* **70**, 247–252.
- Arapoglou, D., Israilides, C.J., Bocari, M., Scanlon, B. and Smith, A. (2002). In *Proceedings of the International Conference. Protection and Restoration of the Environment VII*, p. 469. Skiathos, Greece.
- Arnaiz, C., Elmaleh, S., Lebrato, J. and Moletta, R. (2005). Start up of an anaerobic inverse turbulent bed reactor fed with wine distillery wastewater using pre-colonized bioparticles. *Water Sci Technol* **51**(1), 153–158.
- Arvanitoyannis, I.S., Ladas, D. and Mavromatis, A. (2006a). Wine waste treatment methodology. *Int J Food Sci* **41**(10), 1117–1151.
- Arvanitoyannis, I.S., Ladas, D. and Mavromatis, A. (2006b). Potential uses and applications of treated wine waste. *Int J Food Sci* **41**(5), 475–487.
- Bailey, S., Olin, T., Bricka, R. and Adrian, D. (1999). A review of potentially low-cost sorbents for heavy metals. *Water Res* **33**, 2469–2479.
- Balanya, T., Sana, J., Gonzalez, M. and De la Pena, M. (1994). Utilizacion de compost de residuos solidos urbanos en un viñedo del Penedes. *Viticult/Enol Profesional* **31**, 20–25.
- Bazzoffi, P., Pellegrini, S., Rocchini, A., Mmorandi, M. and Grasselli, O. (1998). The effect of urban refuse compost and different tractor tyres on soil physical properties, soil erosion and maize yield. *Soil Tillage Res* **48**, 275–286.
- Bernard, O., Hadj-Sadok, Z., Dochain, D., Genovesi, A. and Steyer, J.-P. (2001). Dynamical model development and parameter identification for an anaerobic wastewater treatment process. *Biotechnol Bioengin* **75**, 424–438.
- Bertran, E., Sort, X., Soliva, M. and Trillas, I. (2004). Composting winery waste: sludges and grape stalks. *Bioresource Technol* **95**, 203–208.
- Blasi, C., Signorelli, G., Russo, C. and Rea, G. (1999). Product distribution from pyrolysis of wood and agricultural residues. *Indust Engin Chem Res* **38**, 2216–2224.
- Botella, C., De Ory, I., Webb, C., Cantero, D. and Blandino, A. (2005). Hydrolytic enzyme production by *Aspergillus awamori* on grape pomace. *Biochem Engin J* **26**, 100–106.
- Bouhamidi, R., Prevost, V. and Nouvelot, A. (1998). High protection by grape seed proanthocyanidins (GSPC) of polyunsaturated fatty acids against UV-C induced peroxidation. *Comptes Rend Acad Sci Series III Sci Vie III* **321**, 31–38.
- Bustamante, M.A., Perz-Murcia, M.D., Paredes, C. *et al.* (2006). Short-term carbon and nitrogen mineralization in soil amended with winery and distillery organic wastes. *Bioresource Technol* (in press).
- Bustos, G., Moldes, A., Cruz, J. and Dominguez, J. (2004). Evaluation of vinification lees as a general medium for lactobacillus strains. *J Agric Food Chem* **52**(16), 5233–5239.
- Bustos, G., Moldes, A., Cruz, J. and Dominguez, J. (2004). Formulation of low-cost fermentative media for lactic acid production with *Lactobacillus rhamnosus* using vinification lees as nutrients. *J Agricult Food Chem* **52**, 801–808.

- Catley, B. (1972). Pullulan elaboration, an inducible system of *Pullularia pullulans*. *FEBS Lett* **20**, 174–176.
- Chong, K.H. and Volesky, B. (1995). Description of two-metal biosorption equilibria by langmuir-type models. *Biotechnol Bioengin* **47**, 51–60.
- Colin, T., Bories, A., Sire, Y. and Perrin, R. (2005). Treatment and valorisation of winery wastewater by a new biophysical process. *Water Sci Technol* **51**(1), 99–106.
- Costa, F., Moreno, J.L., Hernandez, T., Lax, A., Cegarra, J. and Roig, A. (1989). Mineralization of organic materials in a calcareous soil. *Biol Wastes* **28**, 189–201.
- Delas, J. (2000). La fertilisation de la vigne. In *Collection des Usuels Feret de la Vinge et du Vin*, p. 159. Editions Feret, Bordeaux.
- Del Castilho, P., Chardon, W. and Salomons, W. (1993). Influence of cattle-manure slurry application on the solubility of Cd, Cu, and Zn in a manured acidic, loamy sand soil. *J Environ Qual* **22**, 689–697.
- Deshpande, M., Rale, B. and Lynch, J. (1992). *Aureobasidium pullulans* in applied microbiology: a status report. *Enzyme Microb Technol* **14**, 514–523.
- Diaz, M., Madejon, E., Lopez, F., Lopez, R. and Cabrera, F. (2002). Optimization of the rate vinasse/grape marc for co-composting process. *Process Biochem* **37**, 1143–1150.
- Dittmer, U., Budde, K., Stindt, A. and Weltzien, H. (1990). The influence of the compost extracts on different plants pathogens. *Gesunde-Pflanzen* **42**, 219–235.
- Edwards, L., Burney, J., Richter, G. and MacRae, A. (2000). Evaluation of compost and straw on soil-loss characteristics in erosion plots of potatoes. *Agricult Ecosys Environ* **81**, 217–222.
- Encinar, J., Beltran, F., Gonzalez, J. and Moreno, M. (1997). Pyrolysis of maize, sunflower, grape and tobacco residues. *J Chem Technol Biotechnol* **70**, 400–410.
- Encinar, J., Beltran, F., Bernalte, A., Biro, A. and Gonzalez, F. (1996). Pyrolysis of two agricultural residues: olive and grape bagasse. Influence of particle size and temperature. *Biomass Bioenergy* **11**, 397–409.
- Estaben, M., Polit, M. and Steyer, J. (1997). Fuzzy control for an anaerobic digester. *Control Engin Pract* **5**, 1303–1310.
- Farinella, N.V., Matos, G.D. and Arruda, M.A.Z. (2007). Grape bagasse as a potential biosorbent of metals in effluent treatments. *Bioresource Technol* **98**(10), 1940–1946.
- Faure, D. and Deschamps, A. (1990). Physical-chemical and microbiological aspects in composting of grape pulps. *Biol Wastes* **34**, 251–258.
- Faure, D. (1991). The effect of bacterial inoculation on the initiation of composting of grape pulps. *Bioresource Technol* **37**, 235–238.
- Ferrer, J., Mujica, D. and Paez, G. (1993). Composting from grape pomace. *Rev Téc Fac Ingen* **16**, 191–198.
- Ferrer, J., Paez, G., Marmol, Z. et al. (2001). Agronomic use of biotechnologically processed grape wastes. *Bioresource Technol* **76**, 39–44.
- Finkelman, M. and Vardanis, A. (1982). Simplified microassay for pullulan synthesis. *Appl Environ Microbiol* **43**, 483–485.
- Fiol, N., Escudero, C., Poch, J. and Villaescusa, I. (2006). Preliminary studies on Cr(VI) removal from aqueous solution using grape stalk wastes encapsulated in calcium

- alginate beads in a packed bed up-flow column. *Reactive Funct Polymers*, **66**, 795–807.
- Francis, F.J. (1992). A new group of food colorants. *Trends Food Sci Technol* **3**, 27–30.
- Frankel, E., Waterhouse, A. and Teissedre, P. (1995). Principal phenolic phytochemicals in selected California wines and their antioxidant activity in inhibiting oxidation of human low-density lipoproteins. *J Agricult Food Chem* **43**, 890–894.
- Fuleki, T. and Babjak, L. (1988) Natural food colorants from Ontario grapes. *Highlights Agricult Res Ont* **9**, 6–9.
- Garcia-Calderon, D., Buffiere, P., Moletta, R. and Elmaleh, S. (1998). Anaerobic digestion of wine distillery wastewater in down-flow fluidized bed. *Water Res* **32**, 3593–3600.
- Garcia, C., Hernandez, T. and Costa, F. (1990). The influence of composting and maturation processes on the heavy-metal extractability from some organic wastes. *Biol Wastes*, **31**, 291–301.
- Garcia, C., Hernandez, T. and Costa, F. (1992). Characterization of humic acids from uncomposted sewage sludge by degradative and nondegradative techniques. *Bioresource Technol* **41**, 53–57.
- Genovesi, A., Harmand, J. and Steyer, J. (1999). A fuzzy logic based diagnosis system for the on-line supervision of an anaerobic digester pilot-plant. *Biochem Engin J* **3**, 171–183.
- Gonzalez-Paramas, A., Esteban-Ruano, S., Santos-Buelga, C., Pascual-Teresa, S. and Rivas-Gonzalo, J. (2004). Flavanol content and antioxidant activity in winery byproducts. *J Agricult Food Chem* **52**, 234–238.
- Graef, S. and Andrews, J. (1974). Mathematical modelling and control of anaerobic digestion. *Water Res* **8**, 261–289.
- Graefe, G. (1980). Methods and apparatus for preparing high grade fertilizer. *United States Patent*, **4**, 211–545.
- Haag, J.E., Vande Wouwer, A. and Queinnec, I. (2003). Macroscopic modelling and identification of an anaerobic waste treatment process. *Chem Engin Sci* **58**, 4307–4316.
- Haslam, E. (1980). Oligomeric procyanidins and aging of red wines. *Phytochemistry* **19**, 2577–2582.
- Inbar, Y., Chen, Y. and Hadar, Y. (1986). The use of composted separated cattle manure and grape marc as a peat substitute in horticulture. *Acta Horticult* **178**, 147–154.
- Inbar, Y., Chen, Y., Hadar, Y. and Verdonck, O. (1988). Composting of agricultural wastes for their use as container media: simulation of the composting process. *Biol Wastes*, **26**, 247–259.
- Inbar, Y., Chen, Y. and Hadar, Y. (1992). Characterization of humic substances formed during the composting of solid wastes from wineries. *Sci Total Environ* **113**, 35–48.
- Ingelmo, F., Canet, R., Ibañez, M., Pomares, F. and García, J. (1998). Use of MSW compost, dried sewage sludge and other wastes as partial substitutes for peat and soil. *Bioresource Technol* **63**, 123–129.
- Israilides, C., Smith, A., Harthill, J., Barnett, C., Bambalov, G. and Scanlon, B. (1998). Pullulan content of the ethanol precipitate from fermented agro-industrial wastes. *Appl Microbiol Biotechnol* **49**, 613–617.

- Israilides, C., Scanlon, B., Smith, A., Jumel, K. and Harding, S. (1994). Characterisation of pullulans produced from agro-industrial wastes. *Carbohydrate Polymers* **25**, 203–209.
- Kaewsarn, Y. (1999). Binary adsorption of copper (II) and cadmium (II) from aqueous solutions by biomass of marine alga *durvillaea potarum*. *Separation Sci Technol* **34**, 1595–1605.
- Kammerer, D., Claus, A., Carle, R. and Schieber, A. (2004). Polyphenol screening of pomace from red and white grape varieties (*Vitis vinifera* L.) by HPLC-DAD-MS/MS. *J Agricult Food Chem* **52**(14), 4360–4367.
- Karaka, A. (2004). Effect of organic wastes on the extractability of cadmium, copper, nickel, and zinc in soil. *Geoderma* **122**, 297–303.
- Kratochvil, D. and Volensky, B. (1998). Advances in biosorption of heavy metals. *Trends Biotechnol* **16**, 291–300.
- Lasaridi, K., Stentiford, E. and Evans, T. (2000). Windrow composting of wastewater biosolids: process performance and product stability assessment. *Water Sci Technol* **42**, 217–226.
- Lau, D. and King, A. (2003). Pre- and post-mortem use of grape seed extract in dark poultry meat to inhibit development of thiobarbituric acid reactive substances. *J Agricult Food Chem* **51**, 1602–1607.
- Leckner, B. and Lyngfelt, A. (2002). Optimization of emissions from fluidized bed combustion of coal, biofuel and waste. *Int J Energy Res* **26**, 1191–1202.
- Le Duy, A. and Boa, J. (1982). Pullulan production from peat hydrolysate. *Can J Microbiol* **2**, 143–146.
- Li, Y. S., Liu, C. C. and Chiou, C. S. (2004). Adsorption of Cr(III) from wastewater by wine processing waste sludge. *J Colloid and Interface Sci* **273**(1), 95–101.
- Li, Y. S., Liu, C. C. and Chiou, C. S. (2006). Kinetic studies of adsorption of lead (II) from aqueous solution by wine processing waste sludge. *Water Environ Res* **78**(3), 263–268.
- Madejon, E., Diaz, M., Lopez, R. and Cabrera, F. (2001). Co-composting of sugarbeet vinasse: influence of the organic matter nature of the bulking agents used. *Bioresource Technol* **76**, 275–278.
- Mandelbaum, R., Hadar, Y. and Chen, Y. (1988). Composting of agricultural waste for their use as container media: effect of heat treatments on suppression of *Pythium aphanidermatum* and microbial activities in substrates containing compost. *Biol Wastes* **26**, 261–274.
- Manios, T. (2004). The composting potential of different organic solid wastes: experience from the island of Crete. *Environ Int* **29**, 1079–1089.
- Mantzavinos, D., Hellenbrand, R., Livingston, A. and Metcalfe, I. (1996a). Catalytic wet oxidation of *p*-coumaric acid: partial oxidation intermediates, reaction pathways and catalyst leaching. *Appl Catalysis*, **7**, 379–396.
- Mantzavinos, D., Hellenbrand, R., Livingston, A. and Metcalfe, I. (1996b). Partial wet oxidation of *p*-coumaric acid: oxidation intermediates, reaction pathways and implications for wastewater treatment. *Water Res* **30**, 2969–2976.
- Marakakis, P. (1982). *Anthocyanins as food colors*. Academic Press, New York.

- Mariani, G., Benfenati, E., Fanelli, R., Nicoli, A., Bonfitto, E. and Jacopone, S. (1992). Incineration of agro-industrial wastes and macro- and micropollutants emission. *Chemosphere* **24**, 1545–1551.
- Martinez, M., Miralles, N., Hidalgo, S., Fiol, N., Villaescusa, I. and Poch, J. (2006). Removal of lead(II) and cadmium(II) from aqueous solutions using grape stalk waste. *J Hazardous Mater* **B133**, 203–211.
- Masse, D. and Droste, R. (2000) Comprehensive model of anaerobic digestion of swine manure slurry in a sequencing batch reactor. *Water Res* **34**, 3087–3106.
- Mendez-Acosta, H.O., Femat, R. and Campos-Delgado, D. (2004). Improving the performance on the chemical oxygen demand regulation in anaerobic digestion. *Indust Engin Chem Res* **43**, 95–104.
- Metcalf and Eddy Inc. (1991). *Wastewater engineering, treatment, disposal and reuse*. McGraw-Hill Inc., New York.
- Miyake, Y., Murakami, A., Sugiyama, Y., Isobe, M., Koshimizu, K. and Ohigashi, K. (1999). Identification of coumarins from lemon fruit citrus limon as inhibitors of *in vitro* tumor promotion and superoxide and nitric oxide generation. *J Agricult Food Chem* **47**, 3151–3157.
- Moldes, D., Gallego, P., Rodriguez-Couto, S. and Sanroman, A. (2003). Grape seeds: the best lignocellulosic waste to produce laccase by solid state cultures of *Trametes hirsuta*. *Biotechnol Lett* **25**, 491–495.
- Moletta, R. (2005). Winery and distillery wastewater treatment by anaerobic digestion. *Water Sci Technol* **51**(1), 137–144.
- Moure, A., Cruz, J., Franco, D. *et al.* (2001). Natural antioxidant from residual sources (review). *Food Chem* **72**, 145–171.
- Nakatani, N. (1997). Antioxidants from spices and herbs. In *Natural antioxidants: chemistry, health effects and applications* (F. Shaihidi, ed.), pp. 64–75. AOCS Press, Illinois.
- Nash, D.T. and Nash, S.D. (1993). Grapeseed oil, a natural agent which raises serum HDL levels. *J Am Coll Cardiol* **21**, 318–320.
- Navas, A., Bermudz, F. and Machin, J. (1998). Influence of sewage sludge application on physical and chemical properties of Gypsisols. *Geoderma* **87**, 123–135.
- Negro, C., Tommasi, L. and Miceli, A. (2003). Phenolic compounds and antioxidant activity from red grape marc extracts. *Bioresource Technol* **87**, 41–44.
- Patterson, J.W. (1997). *Industrial waste water technology*. Science Publishers, New York.
- Perez, M., Romero, L. and Sales, D. (2001). Organic matter degradation kinetics in an anaerobic thermophilic fluidised bed bioreactor. *Anaerobe* **7**, 25–35.
- Pinamonti, F., Stringari, G., Gasperi, F. and Zorzi, G. (1997). The use of compost: its effect on heavy metal levels in soil and plants. *Resources Conservat Recyc* **21**, 129–143.
- Prieur, C., Rigaud, J., Cheynier, V. and Moutounet, M. (1994). Oligomeric and polymeric procyanidins from grape seeds. *Phytochemistry* **26**, 781–784.
- Querejeta, J., Roldan, A., Albaladejo, J. and Castillo, V. (2001). Soil water availability improved by site preparation in a *pinus halepensis* afforestation under semiarid climate. *Forest Ecol Manage* **149**, 115–128.
- Raviv, M., Chen, Y. and Inbar, Y. (1986). Peat and peat substitutes as growth media for container-grown plants. In *Developments in plant and soil sciences: the role of organic*

- matter in modern agriculture* (Y. Chert and Y. Avnimelech, eds), pp. 257–287. Martinus Nijhoff Publishers, Dordrecht.
- Ray, S., Bagchi, D., Lim, P. *et al.* (2001). Acute and long-term safety evaluation of a novel IH636 grape seed proanthocyanidin extract. *Res Commun Mol Pathol Pharmacol* **109**, 165–197.
- Renaud, S. and De Lorgeril, M. (1992). Wine, alcohol, platelets, and the French paradox for coronary heart disease. *Lancet* **339**, 1523–1526.
- Ribererau-Gayon, J. and Peybaud, E. (1982). Ciencias y tecnicas de la vinya: Tratados de ampeologia. In *Tomo I: Biologia de la vinya. Suelos de Vinedo*, p. 671. Editorial Hemisferio Sud SA, Argentina.
- Rodriguez-Couto, R., Rodriguez, S., Gallego, R. and Sanroman, P. (2003). Biodegradation of grape cluster stems and ligninolytic enzyme production by *Phanerochaete chrysosporium* during semi-solid-state cultivation. *Acta Biotechnol* **23**, 65–74.
- Saha, B. and Zeikus, B. (1989). Novel highly thermostable pullulanase from thermophiles. *Trends Biotechnol* **7**, 308–316.
- Sanchez, A., Ysunza, F., Beltran-Garcia, M. and Esqueda, M. (2002). Biodegradation of viticulture wastes by *Pleurotus*: a source of microbial and human food and its potential use in animal feeding. *J Agricult Food Chem* **50**, 2537–2542.
- Sanchez, E. and Ferrer, J. (1994). Nutritive solution to hydroponic culture from grape pomace. *RevTéc Facult Ingen* **17**, 197–206.
- Santos-Buelga, C. and Scalbert, A. (2000). Review: proanthocyanidins and tannin-like compounds-nature, occurrence, dietary intake, and effects on nutrition and health. *J Sci Food Agricult* **80**, 1094–1117.
- Sastre, I., Vicente, M. and Lobo, C. (1996). Influence of the application of sewage sludges on soil microbial activity. *Bioresource Technol* **57**, 19–23.
- Shrikhande, A. (2000). Wine byproducts with health benefits. *Food Res Int* **33**, 469–474.
- Sigge, G.O., Britz, T.J., Fourie, P.C. and Barnardt, C.A. (2005). The efficacy of ozone as a pre- and post-treatment option for UASB-treated food processing wastewaters. *Water Sci Technol* **52**(1–2), 167–173.
- Singleton, V. and Rossi, J. (1965). Colorimetry of total phenolics with phosphomolybdic phosphotungstic acid reagents. *Am J Enol Viticult* **16**, 144–158.
- Sistrava, S., Gupta, V.K. and Mohan, D. (1997). Removal of lead and chromium by activated slag – a blast-furnace waste. *J Environ Engin* **123**, 461–468.
- Smagge, F., Mourgues, J., Escudier, J., Conte, T., Molinier, J. and Malmay, C. (1992). Recovery of calcium tartrate and calcium malate in effluents from grape sugar production by electrodialysis. *Bioresource Technol* **39**, 85–189.
- Soliva, M. and Felipo, M.T. (2002). Organic wastes as a resource for Mediterranean soils. In *Biological treatment of biodegradable wastes-technical aspects*, p.19. DG Environment and the JRC, Brussels.
- Sposito, G. (1989). *The chemistry of soils*. Oxford University Press, New York.
- Stojanovic, S., Stojavljevic, T., Vunurevic, N., Vikićranjes, M. and Mandić, A. (1989). Nutritive and feeding value of dried grape pomace in feeding fattening cattle. *Stocarstvo* **43**, 313–319.
- Strack, D. and Wray, V. (1989). Anthocyanins. In *Methods in plant biochemistry Vol. 1 Plant phenolics* (P. Dey and J. Harborne, eds), pp. 325–356. Academic Press, London.

- Tebib, K., Bitri, L., Besancon, P. and Rouanet, J. (1994). Polymeric grape seed tannins prevent plasma cholesterol changes in high cholesterol fed rats. *Food Chem* **49**, 403–406.
- Tebib, K., Rouanet, J. M. and Besancon, P. (1997). Antioxidant effects of dietary polymeric grape seed tannins in tissues of rats fed a high cholesterol-vitamin E-deficient diet. *Food Chem* **59**, 135–141.
- Teissedre, P., Frankel, E., Waterhouse, A., Peleg, H. and German, J. (1996). Inhibition of in vitro human LDL oxidation by phenolic antioxidants from grapes and wines. *J Sci Food Agricult* **70**, 55–61.
- Tobar, P., Moure, A., Soto, C., Chamy, R. and Zuniga, M.E. (2005). Winery solid residue revalorization into oil and antioxidant with nutraceutical properties by an enzyme assisted process. *Water Sci Technol* **51**(1), 47–52.
- Torres, J. and Bobet, R. (2001). New flavanol derivatives from grape (*vitis vinifera*) byproducts. Antioxidant aminoethylthio-flavan-3-ol conjugates from a polymeric waste fraction used as a source of flavanols. *J Agricult Food Chem* **49**, 4627–4634.
- Torrigos, M. and Moletta, R. (1997). Winery wastewater depollution by sequencing batch reactor. *Water Sci Technol* **35**, 2497.
- Vallini, G., Bianchin, M.L., Pera, A. and De Bertoldi, M. (1983). Composting agro-industrial byproducts. *Byocycle* **24**, 43–47.
- Verdonck, O. (1988) Composts from organic waste materials as substitutes for the usual horticultural substrates. *Biol Waste*, **26**, 325–330.
- Veze, A. (1993). La fumure de la vigne. Station fédérale de chercheurs agronomiques de Changins. *Rev Suisse Viticult Arboricult Horticult* **25**, 57–64.
- Villaescusa, I., Fiol, N., Martinez, M., Mirrales, N., Poch, J. and Seralocs, J. (2004). Removal of copper and nickel ions from aqueous solutions by grape stalks wastes. *Water Res* **38**, 992–1002.
- Vlissidis, A. and Zouboulis, A. (1993). Thermophilic anaerobic digestion of alcohol distillery wastewaters. *Bioresource Technol* **43**, 131–140.
- Weng, C.H. (2002). Removal of nickel (ii) from dilute aqueous solution by sludge-ash. *J Environ Engine* **128**, 716–722.
- Yamakoshi, J., Kataoka, S., Koga, T. and Ariga, T. (1999). Proanthocyanidin rich extract from grape seeds attenuates the development of aortic atherosclerosis in cholesterol-fed rabbits. *Atherosclerosis* **142**, 139–149.
- Yuan-shen, L., Cheng-chung, L. and Chyow-san, C. (2004). Adsorption of Cr(III) from wastewater by wine processing waste sludge. *J Colloid Interface Sci* **273**, 95–101.

e-addresses

- http://www.allspiritfitness.com/library/gs/gs_grapeseedoil.shtml
- <http://www.bodybuildingforyou.com/health-supplements/grape-seed-extract.htm>
- http://www.fact-index.com/g/gr/grape_seed_oil.html
- <http://grapeseedoilcorp.com/everything.html>
- http://www.hort.purdue.edu/newcrop/Crops/Grape_seed_oil.html
- http://www.jgpress.com/IBArticles/2000/JF_12.htm

<http://www.jgpress.com/BCArticles/2000/070030.html>

<http://www.nf-2000.org/secure/FP5/F1738.htm>

http://p2library.nfesc.navy.mil/P2_Opportunity_Handbook/9-IV-5.htm

http://www.wholehealthmd.com/refshelf/substances_view/1,1525,793,00.htm

<http://www.woodsend.org/aaa/inst.html>

[http://en.wikipedia.org/wiki/Grape seed oil](http://en.wikipedia.org/wiki/Grape_seed_oil)

Olive Oil Waste Management: Treatment Methods and Potential Uses of Treated Waste

Ioannis S. Arvanitoyannis and Aikaterini Kassaveti

Introduction	453
Olive oil production process and properties of OMW	454
Treatment methods	456
Uses	490
Disadvantages of several olive oil waste treatment methods	539
Inputs and outputs in olive oil industry	552

Introduction

Although olive trees are distributed over all continents, 97% of the world production of olive oil is concentrated in the Mediterranean basin countries: Spain, Portugal, Italy, Greece, Turkey, Tunisia and Morocco (Lopez-Villalta, 1998). The production of olive oil in the EU, Spain, Greece and Italy being the three main producers, amounts to about 80% of the world production. Spain produces more than 30% of the world total production (Bas *et al.*, 2001).

Ironically, while the olive oil itself provides health during its consumption, its resulting by-products (olive mill wastes during olive processing) represent a serious environmental threat, especially in the Mediterranean, Aegean and Marmara regions that account for approximately 95% of worldwide olive oil production (Kestioglu *et al.*, 2005). The safe disposal of these wastes is very crucial because of their polluting effects on soil and water. They are produced in large quantities in short periods of time and must be properly disposed of in order to avoid environmental risks (Cayuela *et al.*, 2005).

The direct impact that vegetable water has on the environment is aesthetic degradation due to its strong odor and dark color. Furthermore, its high organic load is likely to cause eutrophication in cases where it ends up in recipients where exchange rates are low (closed gulfs, lakes etc.). Of all the components, the polyphenols are the most interesting, due to their toxic properties that may affect plants. Besides environmental pollution effects, olive oil waste products can be used in different areas: polyphenols ensure that olive oil retains its quality over time (low acidity), acting as a natural preservative and some have beneficial effects on human health due to their antioxidant action (<http://www.aegean.gr/environment/eda/naias/waste.htm>).

Over the last 20 years, several processes have been introduced in an attempt to reduce the pollutant load of olive mill wastewaters (OMW) (Peredes *et al.*, 1987; Vassilev *et al.*, 1997a, b) based on evaporation ponds, thermal concentration and different physico-chemical and biological treatments (Figure 8.1).

The primary aim of waste legislation is the prevention of waste generation. According to the European Environmental Agency (EEA), waste minimization can take place by means of the following methods: prevention, reduction at source, re-use of products for the same or other purpose, on- or off-site recycling, source- or waste-oriented waste quality and energy recovery (i.e. pyrolysis, combustion, gasification) (Riemer and Kristoffersen 1999; <http://www.oulu.fi/resopt/wasmin/pap.pdf>). Measures to reduce environmental impacts or maintain environmental values have been on an extremely small scale compared with the resources devoted to production support and production-orientated structural objectives. In particular, agri-environmental schemes under Regulation 2078/92 had very little impact on olive farming to date (with the exception of Portugal) and failed to address the scale and range of environmental issues identified (<http://ec.europa.eu/environment/agriculture/pdf/oliveoil.pdf>).

The main target of this chapter is to summarize the various treatment methods of olive oil waste and present the uses of treated waste through flow diagrams, tables and the inputs and outputs (energy consumption, wastewater, solid waste) of several processes.

Olive oil production process and properties of OMW

Three different processes are used for olive oil production: the traditional process (pressing), the process based on a three-phase decanter (three-phase) and the process based on a two-phase decanter (two-phase). These three systems are nearly similar with respect to the oil yield (except pressing), but they significantly differ in the amount and composition of by-product fractions (solid, liquid) (<http://www.biomat-net.org/publications/1859bp.pdf>).

The process of olive oil production can be subdivided in two distinct phases: the preparation of a homogeneous paste and olive oil extraction and purification. In the first stage of olive oil production, the olives are cleaned in a washing plant to remove pesticides, dirt, etc. and then are ground up, either with or without their stones (destoning),

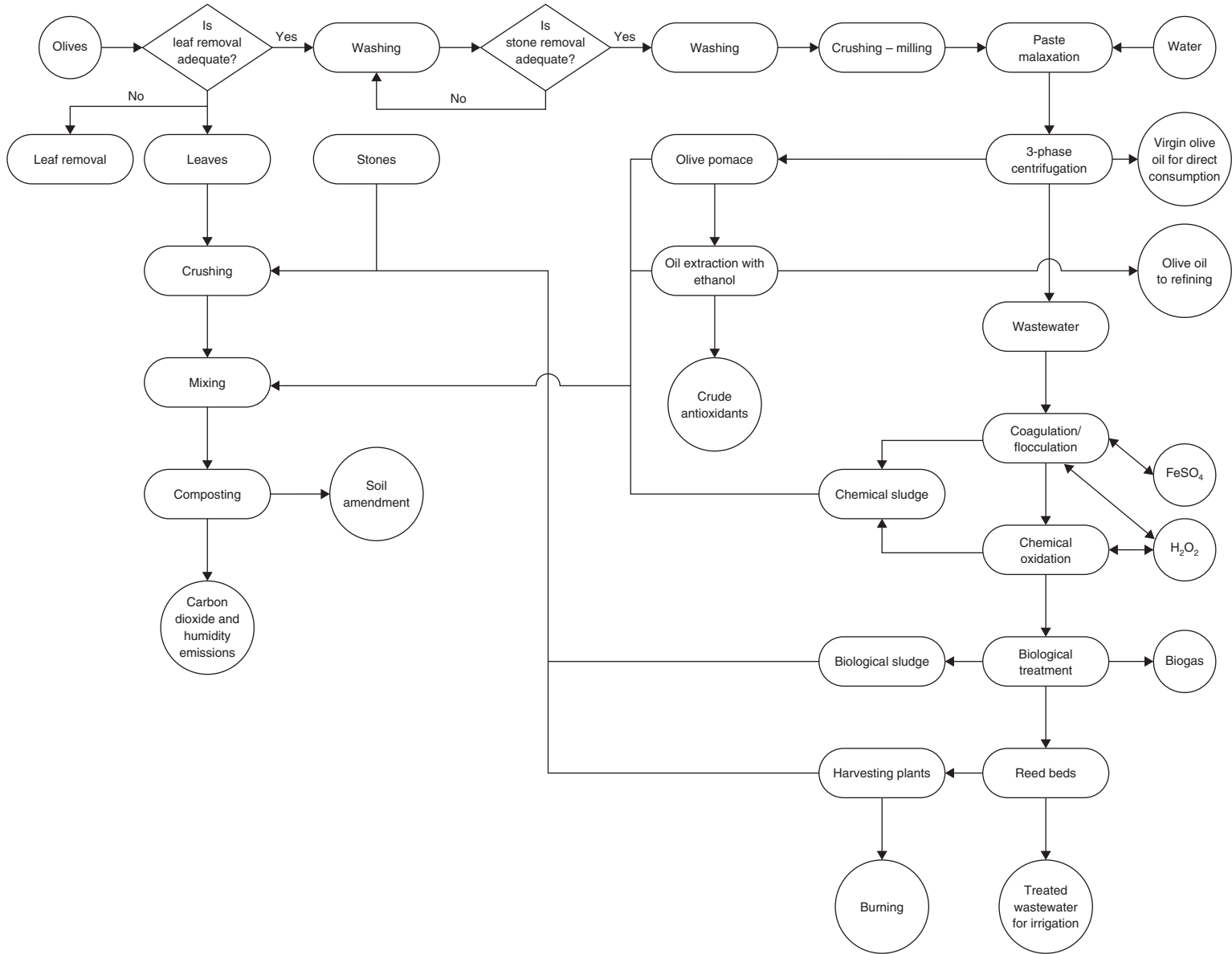

Figure 8.1 An integrated pollution prevention method for olive oil processing (adapted from Vlyssides *et al.*, 2004; <http://www.rirdc.gov.au/reports/NPP/00-187.pdf>; <http://www.laggonsonline.com/reedbebs.htm>)

and mixed into a homogeneous pulp in the malaxation tanks. The paste is separated into three components: vegetation water, oil and husk. Vegetation waters are the brown watery liquid residue which has been separated from the oil by centrifugation or sedimentation after pressing (Fedeli and Camurati, 1981). The husk (pomace) contains the skins, pulp and pit fragments. This separation is most commonly achieved via a horizontal decanter centrifuge or an olive oil press. The three-phase centrifugation system produces the three components listed above, whereas the two-phase centrifugation system produces oil and a watery husk (http://www.oliveoilsource.com/olive_waste.htm#Orchard). To enable the separation of small wastewater quantities and suspended solids that accompany the oil, water is added to the purification process, which is achieved by means of centrifugation (Figure 8.2).

The average amount of OMW produced during the milling process is 1.2–1.8 m³/t of olives. OMW resulting from the production process surpasses 30 million m³ per year in the Mediterranean region (Beccari *et al.*, 1996). The OMW composition is not constant – both qualitatively and quantitatively – and it varies according to the composition of vegetation water, olive oil extraction process and storage time (Niaounakis and Halvadakis, 2006). Wastewaters from the olive oil industry have the following properties: dark brown to black color, acidic smell, high organic content and a chemical oxygen demand/biological oxygen demand (COD/BOD₅) ratio ranging from 2.5 to 5.0, indicating low biodegradability, acidic character, high concentration of phenolic compounds and high content of solid matter (Table 8.1) (Azbar, 2004).

Treatment methods

Since the olive oil industries are incriminated for a high quantity of pollution, it has become imperative to solve this problem by developing optimized systems for the treatment of olive oil wastes. Among the several processes being used nowadays, the ones described are the following: bioremediation, thermal processes, evaporation, membrane processes, electrolysis, aerobic and anaerobic digestion, ozonation, coagulation/flocculation/precipitation and distillation.

Bioremediation

Bioremediation is a treatment process employing naturally occurring microorganisms (yeast, fungi, or bacteria) to break down, or degrade, hazardous substances into less toxic or non-toxic substances (<http://www.modflow.bossintl.com/html/bioremediation.html>). Bacteria, fungi and yeast need nutrients to survive, so they break down organic (carbon-containing) compounds occurring in nature to obtain the required energy for their growth (http://www.woodrow.org/teachers/help/temp_presentations/kim/bioremediation.htm). Bioremediation is not a panacea but rather a ‘natural process’ alternative to methods like incineration, catalytic destruction, use of adsorbents and physical removal and subsequent destruction of pollutants (<http://www.er.doe.gov/production/ober/nabir/needs.html>).

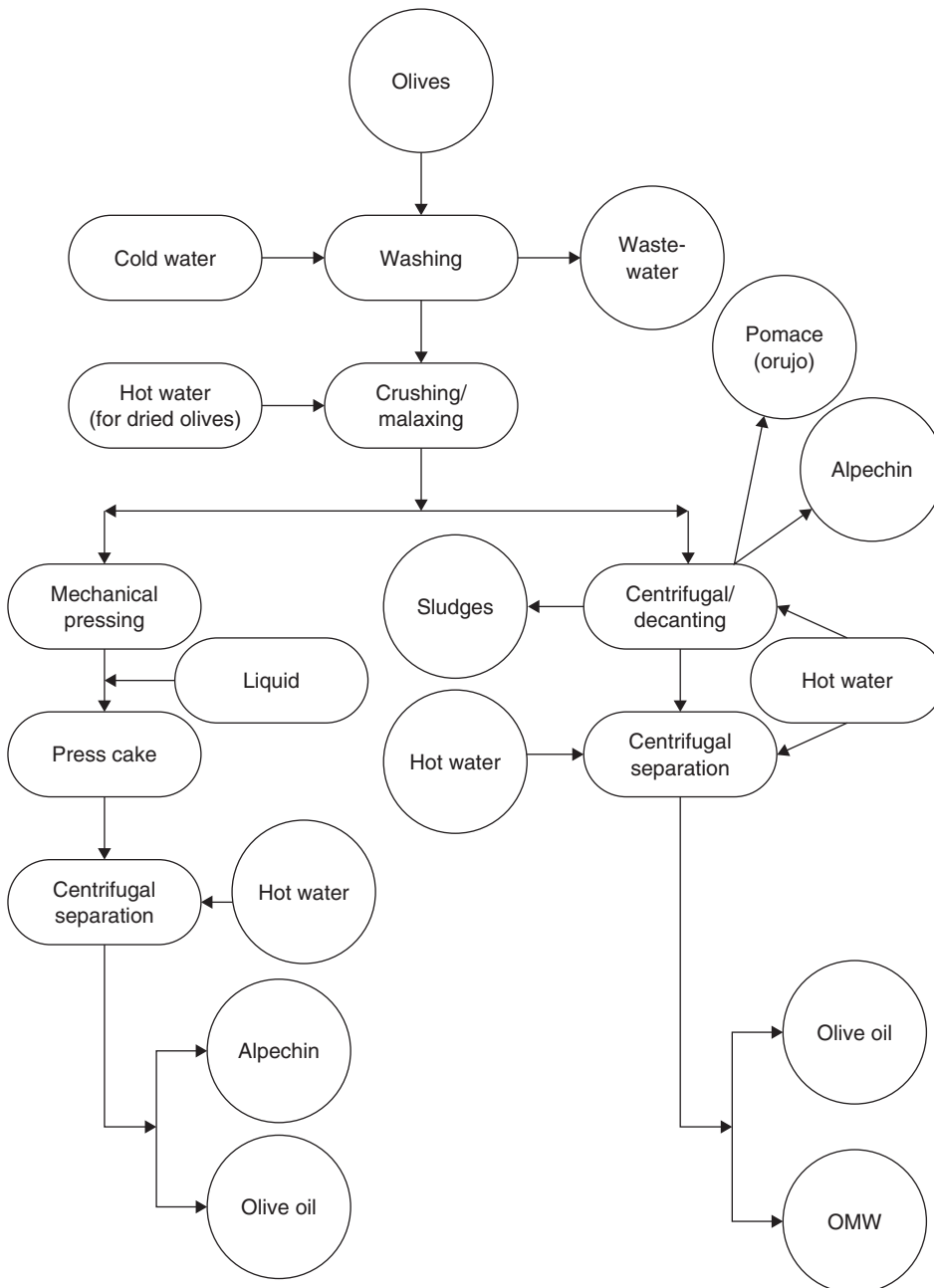

Figure 8.2 Three different olive oil production systems (pressing, three-phase centrifuge, two-phase centrifuge) (adapted from Vlyssides *et al.*, 1996; Niaounakis and Halvadakis, 2006)

Bioremediation occurs either under *aerobic* or *anaerobic* conditions. Under *aerobic conditions*, microorganisms can only survive through consumption of atmospheric oxygen. Under *anaerobic conditions*, since no oxygen is present, the micro-organisms break down chemical compounds in the soil to release the energy they need (<http://www.cpeo.org/techtree/ttdescript/ensolmx.htm>).

Table 8.1 Characteristic parameters of OMW obtained from press and three-phase process

Parameters	Conventional process (pressing)	Three-phase process
pH	4.5–5.0	4.7–5.2
BOD ₅ (g/l)	90–100	33
COD (g/l)	120–130	35–45
Total solids (%)	12	3
Volatile suspended solids (%)	10.5	2.6
Mineral suspended solids (%)	1.5	0.4
Suspended solids (%)	0.1	0.9
Sugars (%)	2–8	1
Total nitrogen (%)	5–2	0.28
Polyphenols (%)	1–2.4	0.5
Oil and grease (%)	0.03–10	0.5–2.3

Adapted from Azbar, 2004; http://www.smaprms.net/DOC/Syria/009_IMOOPW.Dimashki.pdf

Bioremediation technologies can be classified as *in-situ* (bioaugmentation, bioventing, biosparging) or *ex-situ* (bioreactors, landfarming, composting and biopiles). *In-situ* bioremediation treats the contaminated water or soil where it was found, whereas *ex-situ* bioremediation processes involve removal of the contaminated soil or water to another location prior to treatment (<http://www.cpeo.org/techtree/ttdescript/ensolmx.htm>).

In recent years, many researchers have utilized OMW as growth substrates for microorganisms, obtaining a reduction of the COD level, together with enzyme and biomass production (Montedoro and Petruccioli, 1986; Amat di San Filippo and Rinaldi, 1986; Amat di San Filippo *et al.*, 1987; Rodriguez *et al.*, 1988). Yeast species such as *Candida tropicalis* and *Yarrowia lipolytica* as well as bacteria belonging to the species *Azotobacter vinelandii*, *Pseudomonas* spp., *Sphingomonas* spp., *Ralstonia* spp. proved to be suitable for the aerobic biodegradation and detoxification of OMW (Ehaliotis *et al.*, 1999; Di Gioia *et al.*, 2001, 2002).

Composting

Declining availability of landfill space, coupled with increasingly stringent air pollution regulations, accelerated the use of composting as a viable alternative to landfill or incineration (<http://www.info.ngwa.org/membersonly/safety/tips/380-501.html>). Composting is the aerobic processing of biologically degradable organic waste to produce a reasonably stable, granular material, usually also containing valuable plant nutrients. When applied to land, it improves the soil structure and enriches the nutrient content of the soil (<http://www.grc.cf.ac.uk/lrn/resources/waste/management/recovery/composting.php>). The optimum composting conditions are obtained with oxygen supply above 10%, moisture content of 40–60%, carbon: nitrogen ratio of 30:1 and temperature range from 45 to 70°C (<http://www.compost.css.cornell.edu/Factsheets/FS1.html>).

Bioremediation applications

The capacity of *Azotobacter vinelandii* to grow in OMW and its versatility in transforming OMW into organic liquid fertilizer and soil conditioner was examined. The effluent was initially (stage I) treated with calcium hydroxide at a rate sufficient to bring the pH to ~8–10 and then was transferred into the bioreactor (stage II), where it was mixed with a population of *Azotobacter vinelandii* (strain A). The total phosphorus content remained stable over the process, while nitrogen in its ammonium form displayed an upward trend over the remediation period. Apart from the above reported characteristics of OMW, the degradation of phenolic compounds and sugars was examined as well. Phenolic content concentration decreased by 66–99% after 3 days and 100% after 7 days for some of them, while sugars degraded to a great extent after 3 days of treatment (Piperidou *et al.*, 2000).

Garcia-Garcia *et al.* (2000) investigated the capacity of several microorganisms towards treating and reducing the phenol content of OMW. The OMW was inoculated with the following fungi: *Phanerochaete chrysosporium*, *Aspergillus niger*, *Aspergillus terreus* and *Geotrichum candidum*, before being added to the fermenter. Fermentation was carried out in a mixed reactor and the broth was stirred at 500 rpm, aerated at 2 l/min at room temperature. The microorganisms studied reduced the COD in the following order: *Phanerochaete chrysosporium* > *Aspergillus niger* > *Aspergillus terreus* > *Candida tropicalis* > *Azotobacter vinelandii* (Piperidou *et al.*, 2000; Garcia-Garcia *et al.*, 2000) (Figure 8.3). In the case of *Geotrichum candidum*, no COD reduction was observed. As far as *Azotobacter vinelandii* is concerned, after 3 days of treatment a chemical oxygen demand (COD) reduction up to 70% was recorded, although on the 7th day COD increased again. The initial decline of COD could be attributed to the rapid consumption of sugars and other consumable substrates by the *A. vinelandii*. The microorganisms fell in the following order according to the highest phenol removal: *Phanerochaete chrysosporium* > *Aspergillus niger* > *Aspergillus terreus*. No phenols were removed when *Geotrichum candidum* was used (Figure 8.4).

The biodegradation of polyphenols in OMW by three microorganisms (*Geotrichum* spp., *Aspergillus* spp. and *Candida tropicalis*) was investigated in another study. The biodegradation process of OMW was investigated in batch regime by conducting experiments where the initial concentration of COD varied. Furthermore, some tests were performed to determine the most important nutrients necessary for aerobic degradation of OMW. The average COD removals were 55%, 52.5% and 62.8% in wastewaters fermented with *Geotrichum* spp., *Aspergillus* spp. and *C. tropicalis*, respectively. The maximum removal of polyphenols was 46.6% (*Geotrichum* spp.), 44.3% (*Aspergillus* spp.) and 51.7% (*C. tropicalis*). Furthermore, significant decolorization became apparent (Fadil, 2003).

Candida tropicalis YMEC14 was used as an extremophile strain to design an aerobic biotreatment process to detoxify OMW and reduce its polluting organic load. The process was greatly enhanced by directing yeast metabolism towards biodegradation pathways using hexadecane as co-metabolite and by immobilizing yeast cells in calcium alginate beads. Under immobilization conditions, *C. tropicalis* YMEC14 grown at 40°C in OMW supplemented with hexadecane resulted in 69.7%, 69.2% and 55.3%

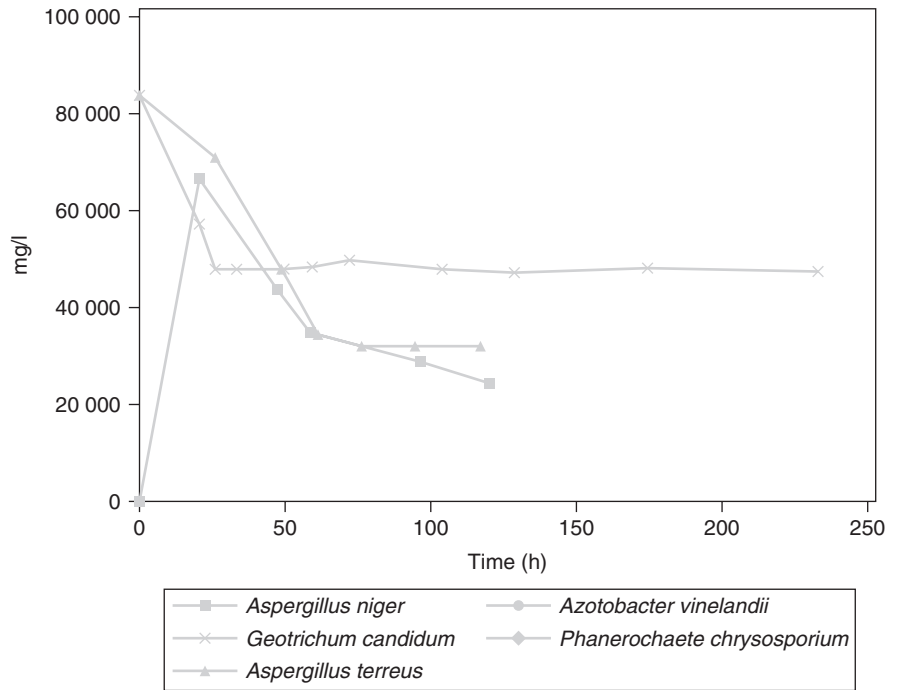

Figure 8.3 COD reduction in the fermentation process (adapted from Piperidou *et al.*, 2000; Garcia-Garcia *et al.*, 2000)

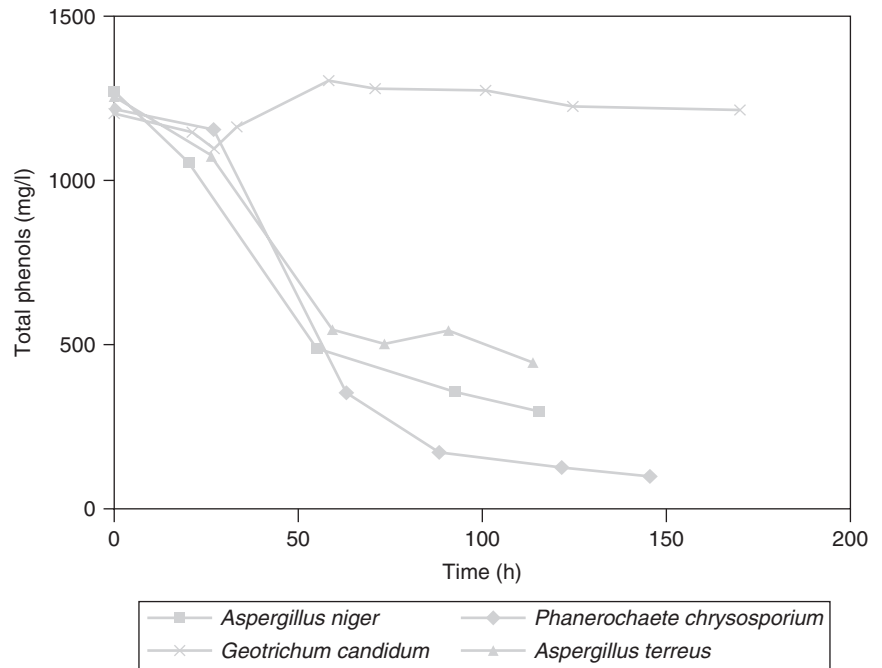

Figure 8.4 Removal of total phenols in the fermentation process (adapted from Garcia-Garcia *et al.*, 2000)

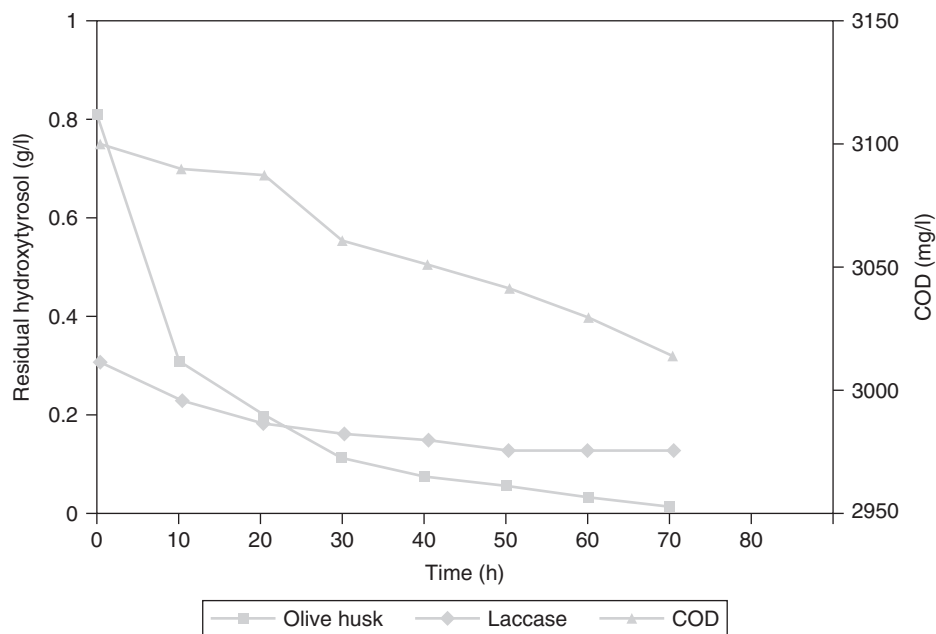

Figure 8.5 Hydroxytyrosol removal and COD reduction from OMW (adapted from Greco *et al.*, 1999)

reduction of COD, monophenols and polyphenols, respectively, after a 24 h fermentation cycle (Ettayebi *et al.*, 2003).

The ability of polyphenol-oxidase from olive husk and a purified microbial phenol oxidase (*Trametes versicolor* laccase) to remove low-molecular phenolics from OMW was examined. The OMW was pretreated in order to flocculate high molecular-weight species, such as polyphenols. The samples were centrifuged and olive husk or laccase was then added to the residue OMW. The runs were carried out at room temperature in a stirred batch reactor. Phenolics removal (with olive husk or laccase) and COD reduction from OMW with olive husk at 20°C (OMW: husk ratio was 80:20 by volume) are shown in Figure 8.5. The reported phenol (hydroxytyrosol, which is the most potent phenolic antioxidant of olive oil and OMW) removal reached up to 90% in less than 50 h and a minor phenolic COD reduction up to 3.22% occurred in the OMW treated by olive husk. The activity of fungal laccase was considerably reduced in OMW (Greco *et al.*, 1999).

The color removal from OMW using aluminum sulfate [$\text{Al}_2(\text{SO}_4)_3 \sim 18\text{H}_2\text{O}$], lime (CaO) and hydrogen peroxide (H_2O_2) was investigated by Flouri *et al.* (1996) along with the decolorizing effect of sixteen strains of *Pleurotus*. Although all chemical substances displayed a strong decolorizing effect, the most effective was hydrogen peroxide, followed by lime and alumina. The tests with *Pleurotus* isolates were carried out on plates using different concentrations (25%, 50%, 75% and 100%) of sterilized OMW solidified with 1.5% agar. For all strains tested, decolorization proceeded more slowly than radial growth. Among the six *Pleurotus* species, *P. cornucopiae* (ATCC 38547) and *P. ostreatus* (ATCC 34675) were the most effective.

The ability of commercial phenol oxidase (laccase) and isolated strains of *Pleurotus* spp. to detoxify OMW was tested by Iconomou *et al.* (2006). Toxicity assays of treated and untreated OMW examining the potential effects against the seeds of *Lepidium sativum*, *Artemia* spp., *Heterocypris incongruens* and *Daphnia magna* and on the growth of lettuce (*Lactuca sativa*) and tomato (*Lycopersicon esculentum*) plants were performed. OMW treatment with commercial laccase resulted in 44% reduction of total phenols, whereas treated OMW remained phytotoxic. Significant dephenolization (around 79%) was achieved by using strains of *Pleurotus ostreatus* grown in a bioreactor, in OMW without any addition of nutrients. The toxicity of bioremediated OMW against the seeds of *Lepidium sativum*, *Artemia* spp. and *Heterocypris incongruens* decreased, in comparison with the toxicity against *Daphnia magna*, which was not affected by the treatment. Ground dry weight of plants irrigated with OMW was 65% and 80% of the control in lettuce and 68% and 71% of the control in tomato, respectively.

In an experiment conducted by Lanciotti *et al.* (2004), 62 different strains (Y, RO, PO and others) of *Yarrowia lipolytica* were inoculated in undiluted OMW, after 72 h of incubation at 25°C. Not all strains of *Yarrowia lipolytica* were shown to have the same ability to degrade OMW, even though all strains grew in undiluted OMW. A number of strains caused COD reduction varying from 1.5 and 41.2% of the initial value and others were able to produce high concentration of lipase, biomass and citric acid, which is widely used in a great number of applications. Some strains, such as Y9, Y17, PO1, PO18, PO20, RO18, B16, C11 and B7, in addition to high lipase activity, caused a considerable COD reduction. The strains Y17, RO18, B16, PO20 and C21 caused reduction in polyphenol content, while others (Y2, RO19 and PO17) an apparent increase. Furthermore, the strains Y9, Y2, B16, C11, Y17 and PO1 were able to produce a high concentration of citric acid.

The performance and enzymatic strategy exhibited by basidiomycete Euc-1, a laccase producing strain, was investigated during the biodegradation of OMW. This strain yielded better decolorization of solidified OMW than *Phanerochaete chrysosporium* and removed 90% of phenols (initial concentration = 800 mg/l), 73% of color (initial A465 = 4.4) and 45% of COD in batch cultures containing OMW. Since partial phenol removal occurred before the detection of enzymatic activity, no plausible correlation could be established between them. In contrast, decolorization occurred only after the detection of laccase activity and coincided with its production over time. Two laccase fractions (Lac1 and Lac2) were separated with anion exchange chromatography. OMW strongly induced Lac2 that was almost absent in defined liquid medium. Furthermore, Lac2 was the main laccase fraction in the presence of OMW. Basidiomycete Euc-1 and its ligninolytic system could be a useful tool for the bioremediation of wastewater generated in the process of olive oil extraction (Dias *et al.*, 2004).

Scioli and Vollarò (1997) examined the ability of *Yarrowia lipolytica* to reduce COD and produce biomass. The OMW was inoculated with *Y. lipolytica* for 48 h at 30°C, before being added to the fermenter. Fermentation was carried out in a fermenter and the broth was stirred at 500 rpm, aerated at 0.5 l/min at 30°C. On the other hand, Assas *et al.* (2002) investigated the ability of *Geotrichum candidum* to decolorize both fresh and stored OMW. An aerated batch bioreactor, adequate for *Geotrichum candidum*

growth on OMW, was fed with fresh and stored (-20°C) OMW. Mycelia of *Geotrichum candidum* grew on fresh OMW during the first three days of incubation and resulted in 75% color removal, while on stored OMW the growth of fungus was inhibited and no decolorization was observed. However, *Yarrowia lipolytica* led to biomass production in the range of 22.45 g/l after 20 h treatment (Figure 8.6). COD reduction of fresh OMW (50%) occurred rapidly over the first 3 days of the process, while COD reduction of stored OMW (25%) was reported for the first 2 days. *Yarrowia lipolytica* caused a COD reduction up to 80% in 24 h (Figure 8.7). Moreover, *Yarrowia lipolytica* initiated lipase production of 770 U/l at 20 h (initial 190 U/l), fats metabolism (after 6 h and completed after 14 h) and sugars (after 12 h). It was also noticed that the pH of fresh and stored OMW went through many changes over time. A clear decrease in pH was observed for fresh OMW due to the sugar consumption by *Geotrichum candidum*, while on stored OMW the pH increased up to 7.8.

OMW from two different olive-harvesting periods and a sludge produced by a two-phase centrifugal decanter were used for the isolation of both fungal and bacterial indigenous strains, which were evaluated for their ability to detoxify the wastes produced by the olive-oil industry. The isolation process was carried out through the use of culture media containing 25% and 100% v/v OMW and 10% w/v sludge. Numerous strains of indigenous microorganisms were isolated from OMW and sludge, which decreased phytotoxicity up to seventeen times as compared to the control (OMW), while some of the strains decreased phenolic content (up to 43%) and/or color (up to

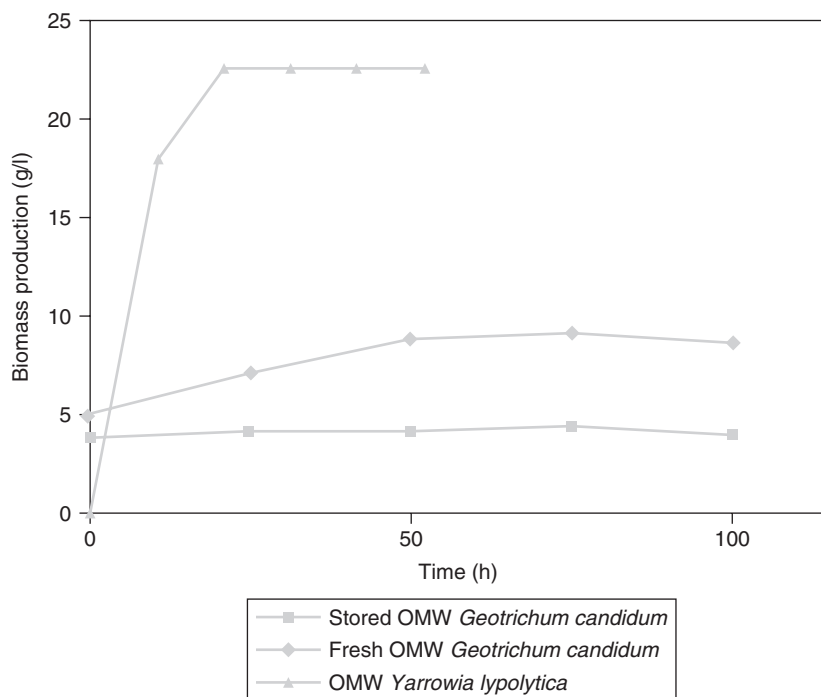

Figure 8.6 Biomass production of *Geotrichum candidum* and *Yarrowia lipolytica* (adapted from Scioli and Vollaro, 1997; Assas *et al.*, 2002)

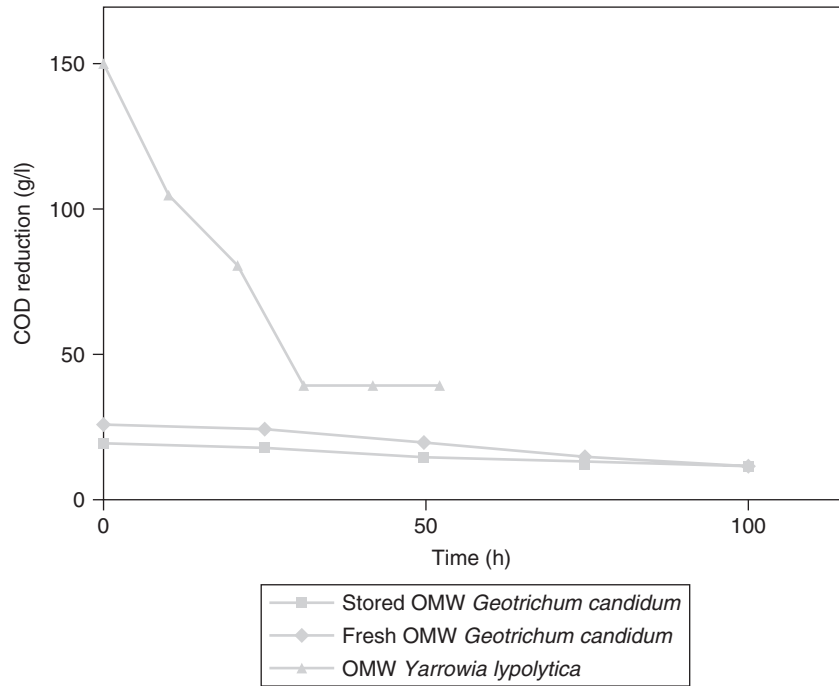

Figure 8.7 COD reduction of *Geotrichum candidum* and *Yarrowia lipolytica* (adapted from Scioli and Vollaro, 1997; Assas *et al.*, 2002)

85%). For all isolates, total content in polyphenolics and germination index were not correlated; some strains failed to reduce phenolics, although they decreased phytotoxicity by 66.3–126.9% (Ntougias *et al.*, 2006).

The effect of depolymerization of OMW phenolic compounds with low and high molecular weight by *Lactobacillus plantarum* on the transport of phenolics from OMW to olive oil was studied by Kachouri and Moktar (2003). Incubation of olive oil samples with fermented OMW by *L. plantarum* caused a decrease of polyphenols in OMW and increase in oil with multiple biological effects. The lower total phenolic content in fermented OMW of 845 mg/l in comparison to OMW control with 1247 mg/l was the result of the depolymerization of phenolic compounds of high molecular weight by *L. plantarum*. Fermentation with *L. plantarum* induced reductive depolymerization of phenolic compounds of OMW which are more soluble in olive oil. The total simple polyphenols content of olive oil mixed with OMW and fermented by *L. plantarum* was higher (703 mg/l) than an olive oil control mixed with OMW (112 mg/l). Simple polyphenols content increased in olive oil when *L. plantarum* was added to OMW, especially for oleuropein, *p*-hydroxyphenylacetic, vanillic and ferulic acids and tyrosol.

Mixtures of two different flocculated fractions of OMW (FOMW1 and FOMW2) and olive leaves (OL) were selected for composting. FOMW1 came from OMW of the two-phase extraction system, while FOMW2 came from OMW of the three-phase system and contained olive pulp. The composition of the two mixtures (C1 and C2) was as follows: C1; 65% FOMW1 + 35% OL (dry weight), equivalent to 80% FOMW1 + 20%

OL (fresh weight), C2; 74% FOMW1 + 25% OL + 1% urea (dry weight), equivalent to 91.5% FOMW1 + 8.0% OL + 0.5% urea (fresh weight). Both mixtures were composted in trapezoidal piles by the Rutgers static composting system (Finstein *et al.*, 1985). Air was blown from the base of the pile through tubes at 55°C. A greater portion of the OM fraction was degraded in compost 1 (64%) than in compost 2 (40%). About 60% of the initial contents of lignin and cellulose were degraded during composting in C1, compared to 38–39% in C2. Most of the fat was degraded during composting. Higher microbial activity was recorded in C2 attributed to the presence of nutrients, particularly nitrogen, supplied by urea hydrolysis in this pile (Garcia-Gomez *et al.*, 2002b).

Robles *et al.* (2000) isolated seven strains of *Penicillium* from OMW disposal ponds which were tested for biomass production and biodegradation of undiluted OMW. Best results were obtained by using strain P4, which formed 21.50 g (dry weight) of biomass per liter of undiluted wastewater after 20 days of cultivation. This and other strains also carried out an outstanding reduction of COD accompanied by an increase in the phenolic content of OMW and pH. The process could be accelerated by agitation. OMW fermented with *Penicillium* P4 was devoid of its initial antibacterial activity against *Bacillus megaterium* ATCC 25848.

A mixture of olive marc, wheat straw and OMW was composted for a year. The pile was aerated every 15 days and homogenized. The decrease in lipid and water-soluble phenol content after 10 months of composting amounted to 97% and 66%, respectively. Organic matter (OM) losses were higher over the first 3 months of the process, because of the greater activity of microorganisms. However, at a later stage, the OM degradation was shown to be restricted by the high lignin content of the main components of OM (lignin, cellulose, hemillulose). Moreover, during composting an increase in nitrogen and ash content was observed contrary to the recorded decrease in organic carbon (Figure 8.8). The lignin was less degraded (43.8%) than cellulose (58%) and hemillulose, the latter being the most degraded component, 76% by the end of the process (Baddi *et al.*, 2003).

Pleurotus ostreatus grown in bioreactor batch cultures in a model phenolic wastewater (diluted and sterilized OMW) caused significant phenolic removal. Laccase, the sole ligninolytic enzyme detected in the growth environment, was produced during primary metabolic growth. When the fungal biomass increased in the reactor (during repeated batch experiments) the rate of reducing sugars consumption progressively increased, but a phenolic fraction seemed to be strongly resistant to oxidation. The toxicity of OMW against the seeds of *Lepidium sativum* and the marine *Branchiopoda artemia* spp. significantly decreased after biotreatment. On the other hand, the toxicity against the freshwater *Branchiopoda daphnia magna* was not affected by the treatment, whereas *Ostracoda heterocypris incongruens* slightly decreased on the soil and freshwater sediments. Both treated and untreated OMW, used as water for lettuce and tomato plant irrigation, did not considerably affect the uptake of several nutrients by the cultivated plants, but resulted in a decrease in the plant yields minimized when high OMW dilutions were used. As a conclusion, *P. ostreatus* is able to reduce phenolic content and toxicity of sterilized OMW in bioreactor cultures. However, high OMW dilutions should be used, and/or additional treatment should be applied prior to use of OMW in the environment, e.g. as water for irrigation. However, further

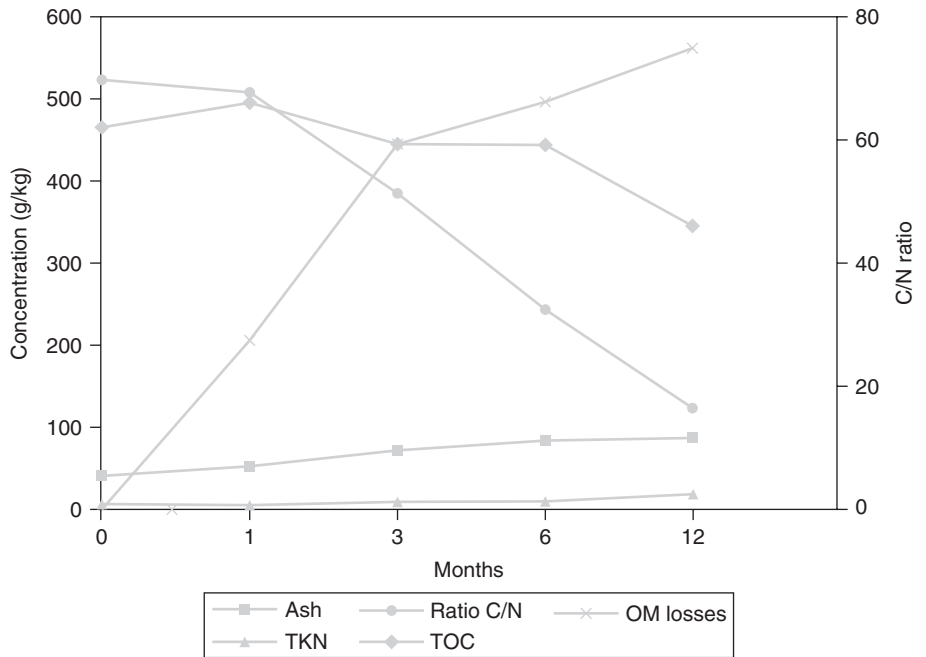

Figure 8.8 Changes in some parameters during composting of the olive-mill wastes-straw mixture (dry weight basis) (adapted from Baddi *et al.*, 2003)

research is required in order to transfer this technology to industrial conditions (e.g. by using unsterilized OMW) (Aggelis *et al.*, 2003).

Growth and polyphenol biodegradation by yeasts were studied on OMW. According to the results, the selected yeast removed phenols from the culture medium and high biomass was produced. The degradation of phenols reached up to 44% after the 5th day of fermentation. The characterization of polyphenolic compounds with high performance liquid chromatography (HPLC) showed several compounds with absorbance on 280 nm. The most abundant compound was hydroxytyrosol, but the majority of the phenols disappeared; the remaining compounds were in traces after 30 days (Fakharedine *et al.*, 2006).

OMW was transferred into a laboratory-scale bioreactor, where it was mixed with a population of *Phanerochaete flavido-alba*. After 14 days (336 h) of treatment, the reduction of color and aromatic compounds obtained reached 70.3 and 51.7%, respectively. The decrease in aromatic compounds content and in color started at 200 h (Figure 8.9). A toxicity reduction in OMW up to 70% was reported (Blaquez *et al.*, 2002).

Tsioulpas *et al.* (2002) studied the ability of several *Pleurotus* spp. strains to remove phenolic compounds from OMW. All strains tested in their work were able to grow on OMW without any addition of nutrients and any pretreatment, except sterilization. High laccase activity was measured in the growth medium, while 69–76% of the initial phenolic compounds were removed. The black color of OMW became yellow-brown and brighter as the strains grew. The lowest phenolic concentrations were reached after 12–15 days. A decrease in phytotoxicity, as described by the Germination Index parameter, was

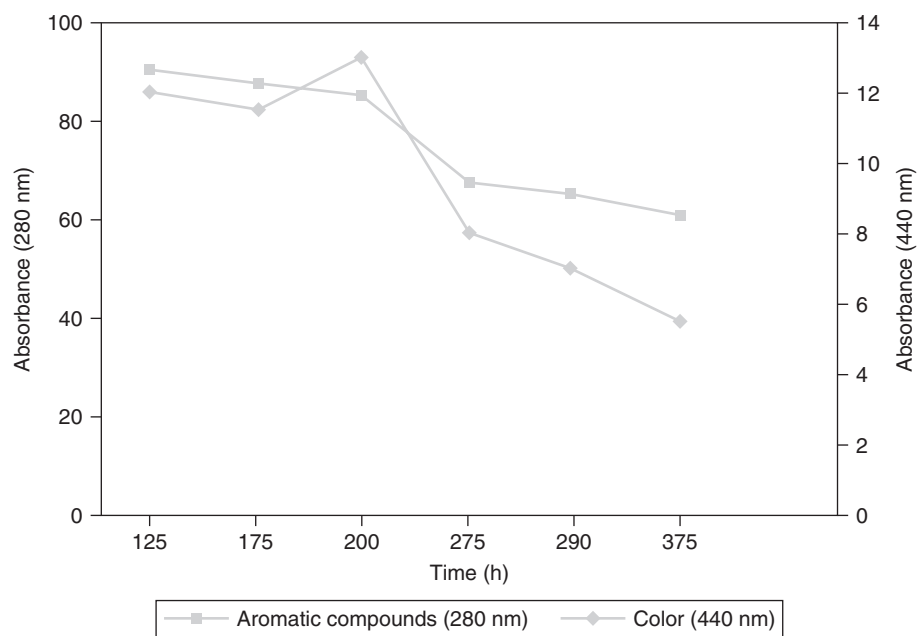

Figure 8.9 Evolution of aromatic compounds and color concentration (adapted from Blaquez *et al.*, 2002)

noticed in the OMW treated with some *Pleurotus* spp. strains, although this decrease was not proportional to the phenolic removal. A new parameter, namely Phenol-toxicity Index, was considered in this experiment. Employment of this parameter showed that the remaining phenolics and/or some of the oxidation products of the laccase reaction in the treated OMW were more toxic than the original phenolic compounds.

The bacterium *Bacillus pumilus* 123 was used in order to reduce the phenol content of olive mill wastewaters (alpechin). The results showed that the bacterium was very effective in reducing the phenol content of alpechin at concentrations ranging from 40 up to 100%. It was also observed that, in addition to a slight reduction in total phenols, new phenolic compounds not present in the original alpechin were generated at concentrations of 80% (Ramos-Cormenzana *et al.*, 1996).

Olive mill solid residue (OMSR) was pretreated with sodium hydroxide in order to reduce its sugar content. Then enzymatic saccharification was carried out by means of a batch reactor filled with treated OMSR and *Trichoderma reesei* enzyme. The maximum saccharification yield (50%) was reported at the following optimum experimental conditions: pH = 5, temperature 5°C, E/S: enzyme mass to substrate mass ratio = 0.1 g enzyme/g OMSR (Abdi *et al.*, 2000).

Fungi *Pycnoporous coccineus*, *Pleurotus sajor caju*, *Coriolopsis polyzona* and *Lentinus tigrinus* were inoculated onto OMW. The ability of these fungi to decolorize OMW at four different COD values (100, 75, 50 and 25 g/l) was tested. All fungi were shown to be effective in decolorization and COD removal of OMW at 50 and 75 g/l COD. At 100 g/l COD only *P. coccineus* and *P. sajor caju* were effective, while *P. sajor caju* and *C. polyzona* showed levels of decolorization as high as 75% when COD was

50 g/l. Mono and polyaromatics were considerably reduced after 20 days incubation with *C. polyzona* (Jaouani *et al.*, 2003).

Casa *et al.* (2003) investigated the potential of an enzyme-based treatment in removing OMW phytotoxicity. To this aim, germinability experiments on durum wheat (*Triticum durum* Desf. cv. *Duilio*) were conducted in the presence of different dilutions of raw or enzyme-treated OMW. OMW treatment with laccase resulted in a 65% and 86% reduction in total phenols and ortho-diphenols respectively, due to their polymerization as revealed by size-exclusion chromatography. Raw OMW exerted a significant concentration-dependent inhibition on the germinability of durum wheat seeds which was evident up to a dilution rate of 1:8. When the effluent was treated with a fungal laccase, the germinability increased by 57% at a 1:8 dilution and by 94% at a 1:2 dilution, as compared to the same dilutions using untreated OMW. The treatment with laccase also decreased the mean germination time by about a day compared to untreated controls. These results revealed that germination inhibition due to OMW can be effectively reduced using fungal laccase, thus suggesting that phenols are the main determinants of its phytotoxicity.

Two aerobic bacterial strains, *Ralstonia* spp. and *Pseudomonas putida*, were tested for their capacity to degrade monocyclic aromatic acids responsible for the toxicity of OMW. It was found that both bacteria were capable of metabolizing monocyclic aromatic compounds occurring at high concentrations in OMW (Di Gioia *et al.*, 2001).

The transformation by an oxidoreductase (a laccase from *Rhus vernificera*) of a mixture of four phenols (catechol, methylcatechol, *m*-tyrosol and hydroxytyrosol) that simulates a typical wastewater derived from an olive oil factory was investigated. The results of this study confirmed that laccase-mediated transformation of phenols depended on the nature and the initial concentration of the involved phenol, the time course of the reaction and, mainly, on the complexity of the phenolic incubation mixture. Actually, the four phenols each have a completely different response to enzyme action both in terms of quantitative and kinetic transformation. For example, after 24 h incubation, methylcatechol was completely removed, whereas 30% of untransformed hydroxytyrosol and catechol and more than 65% of *m*-tyrosol were still present in the reaction mixture. A reduction in enzyme activity occurred for all phenols after enzymatic oxidation. No correspondence between phenol transformation and disappearance of enzymatic activity was observed, thus suggesting that different mechanisms are probably involved in the laccase-mediated transformation of the four phenols. The behavior of the phenols became more complex when an increasing number of phenols was present in the reaction mixture and, even more so, when different concentrations of phenols were used. Competitive effects may arise when more than one phenol is present in the reaction solution and interacts with the enzyme (Gianfreda *et al.*, 2003).

Kyriacou *et al.* (2005) developed a method for the treatment of OMW, combining both biological treatment using *Aspergillus niger* and electrochemical treatment in the presence of H₂O₂. In the first treatment step of the process, the acidified OMW was fed to a batch bioreactor, while in the electrochemical step the effluent was oxidized (electrode type: iron stainless steel, Ti/Pt alloy, 60 min, 2.5% H₂O₂). In the biological treatment step, the recorded COD reduction varied between 66 and 86%, while the

concentration of selected phenols was reduced by 65%. In the electrochemical treatment, the removal percentages achieved both for COD and phenols reached 96%.

Ruiz *et al.* (2002) demonstrated that *Phanerochaete flavido-alba* discoloration, dephenolization and detoxification of OMW were associated with changes in the ligninolytic major exo-enzymes accumulated in the cultures. This publication described the effect of the two main OMW components (monomeric aromatic compounds and a major brownish polymeric pigment) on extracellular *P. flavido-alba* ligninolytic enzymes. Laccase was the sole ligninolytic enzyme detected in cultures containing monomeric aromatic compounds. Laccase and an acidic manganese-dependent peroxidase (MnPA, pI 62.8) were accumulated in cultures with OMW or polymeric pigment. Furthermore, modified manganese-dependent peroxidases were observed mainly in OMW-supplemented cultures. Laccase was more stable to the effect of OMW toxic components and was accumulated in monomeric aromatic-supplemented cultures, suggesting a more important role than manganese-dependent peroxidases in OMW detoxification. Alternatively, MnPA accumulated in cultures containing the polymeric pigment seemed to be more essential than laccase for degradation of this recalcitrant macromolecule by *P. flavido-alba*.

Pleurotus ostreatus mycelia were inoculated on media containing 20% OMW; higher OMW concentration inhibited the fungus growth. The ability of fungus phenol-oxidase to reduce OMW phenols and toxicity was thoroughly studied. It was found that after 100 h of treatment, phenols decreased by 90% and the toxicity of OMW was substantially reduced. Apart from fungus phenol-oxidase, a purified phenol-oxidase was also employed for OMW treatment. The latter was shown to result in phenol reduction up to 90%, but it had no effect on the toxicity level (Martirani *et al.*, 1996).

Phanerochaete flavido-alba is able to decolorize and detoxify OMW in a process in which simple and polymeric phenols are removed. An unusual acidic manganese peroxidase (MnP) was accumulated during the degradation course. This microorganism produced two families of MnPs. MnP1 has an apparent molecular weight of 45 kDa and is secreted as a mixture of isoenzymes with pH ranging from 5.6 to 4.75. MnP2, which is produced as a unique isoenzyme, has an apparent molecular weight of 55.6 Mr and an unusual acidic pH lower than 2.8. The higher specific peroxidase activity for purified MnP2 was for Mn²⁺ oxidation. Hydroquinone and methylhydroquinone oxidation with MnP2 was Mn²⁺ dependent in reaction mixtures without exogenous H₂O₂. Conversely, ABTS oxidation was Mn²⁺ independent. Two different DNA fragments (*mnpA* and *mnpB*), amplified by polymerase chain reaction (PCR), using MnP2 N-terminal sequence and oligonucleotides deduced from two conserved sequences of other MnPs, code for MnPs that belong to the *P. chrysosporium mnp2* subfamily on the basis of intron position. The structure of *mnpA* and *mnpB* seems to be related to known manganese peroxidase genes, but *mnpA* encodes an alanine instead of a serine (Ser168) regarded as invariant within typical MnPs (De la Rubia *et al.*, 2002).

Enzyme laccase, produced by fungus *Pycnoporus coccineus*, is responsible for OMW decolorization and COD and phenolic compounds decrease. The produced laccase, a glycoprotein, was purified from the medium with Cu²⁺-ethanol and then the OMW was treated with laccase. The highest laccase level was attained in Cu²⁺-ethanol medium (100 000 U/l after 45 incubation-days). The enzyme was stable at pH 7, at

room temperature and showed a half-life of 8 and 2 h at 50 and 60°C, respectively (Jaouani *et al.*, 2005).

An immobilized lacasse, from the white-rot fungus *Lentinula edodes*, was used for the OMW treatment. Preliminary batch experiments were performed by incubating filter-sterilized OMW at 30°C with immobilized laccase using an effluent volume/catalyst weight ratio equal to 500:1. In subsequent experiments, OMW treatments with immobilized laccase were performed at the same temperature in a column operated as a fluidized bed reactor, using an effluent volume/catalyst weight ratio equal to 200:1. Preliminary batch experiments showed a significant reduction of total phenols and *ortho*-diphenols up to 67 and 72% (after 24 h), respectively, whereas in subsequent experiments a significant decrease of total phenols and *ortho*-diphenols was observed as well as decolorization of OMW (D'Annibale *et al.*, 1999).

Thermal processes

Thermal treatment is a process where heat is applied to waste in order to sanitize it and reduce its bulk, prior to final disposal. The process may or may not involve energy recovery. The primary function of thermal treatment is to convert the waste into a stable and usable end product and reduce the amount that requires final disposal in landfills (http://www.dublincity.ie/shaping_the_city/environment/dublin_waste_to_energy/waste_to_energy/index.asp). The end products of a thermal process are ash, gases, such as carbon dioxide (CO₂) and nitrogen oxide (NO_x), and water.

Thermal waste treatment technologies fall into two broad categories:

- 1 those in which waste is combusted – burnt in the presence of oxygen, i.e. incineration technologies
- 2 those in which waste is heated in the presence of little or no oxygen so that there is no direct combustion, i.e. pyrolysis (sometimes referred to as thermolysis) and gasification (http://www.noharm.org/library/docs/Update_on_Pyrolysis.pdf).

In general, thermal treatments accomplish three goals: detoxification of hazardous waste by decomposing organic compounds contained in the waste; waste volume reduction; and waste conversion to solids by vaporizing water and other liquids the waste may contain (<http://www.ncseonline.org/NLE/CRS/abstract.cfm?NLEid=15892>).

The continuously increasing world energy demand is proportional to population increase and economic development. In order to generate the necessary energy to supply the increasing energy demand and also to comply with the regulations related to environmental pollution, use of biomass as a renewable energy source is becoming more and more important. Energy produced by using biomass promotes 'sustainable development' thus complying with the targets stipulated in the Kyoto Agreement (Topal *et al.*, 2003).

Incineration

Incineration is the combustion of waste in a controlled way in order to decompose it or convert it into less hazardous, less bulky or more controllable constituents. Incineration

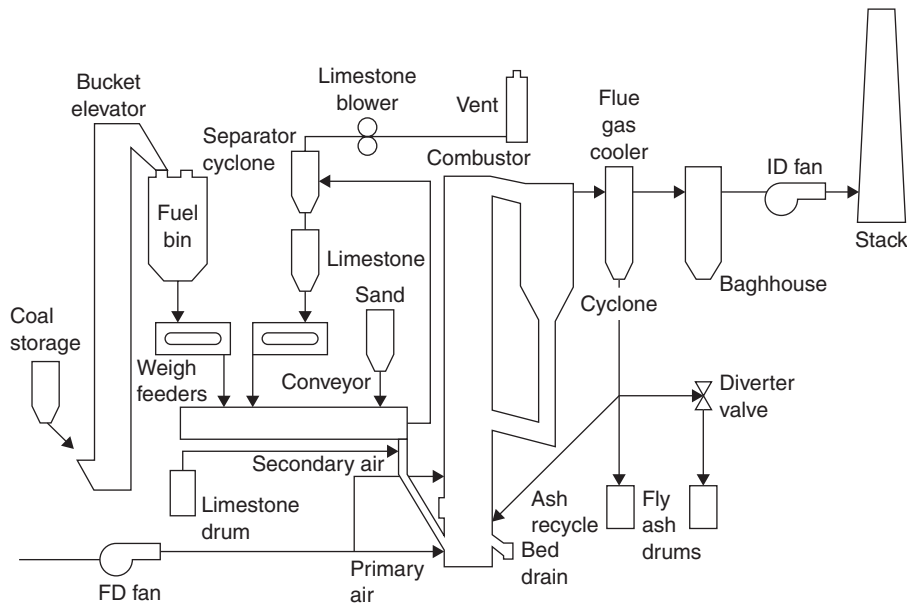

Figure 8.10 A fluidized bed combustion system (adapted from http://www.nrcan.gc.ca/es/etb/cetc/cetc01/htmldocs/factsheet_fluidised_bed_combustion_e.html)

may be used to dispose of a wide range of waste streams including municipal solid waste, commercial, clinical and certain types of industrial waste (http://www.wasteonline.org.uk/resources/Wasteguide/mn_wmo_thermtreatment_incin.html). It is an interim waste processing function and not the final stage of waste management. Incineration produces combustion products released into the atmosphere as gases and ash. There are different types of incinerators, such as circulating bed combustor, fluidized bed (Figure 8.10), infrared combustion and rotary kilns.

Pyrolysis

Pyrolysis is the thermal treatment of excavated soils or sludges whereby chemical decomposition is induced in an anaerobic and heated environment (<http://www.lanl.gov/orgs/d/d4/enviro/etcap/overview.html>). In practice, it is not possible to achieve a completely oxygen-free atmosphere; actual pyrolytic systems are operated with less than stoichiometric quantities of oxygen. Since a certain amount of oxygen will be present in any pyrolytic system, nominal oxidation is bound to occur (<http://www.frtr.gov/matrix2/section4/4-25.html>). Rotary kiln (Figure 8.11), fluidized bed furnace (Figure 8.12) and molten salt process are used for waste pyrolysis.

Gasification

Gasification is the thermal decomposition of organic material at elevated temperatures in an oxygen restricted environment. Pyrolysis, gasification and incineration can be considered within the frame of combustion. Pyrolysis, with zero combustion, is at

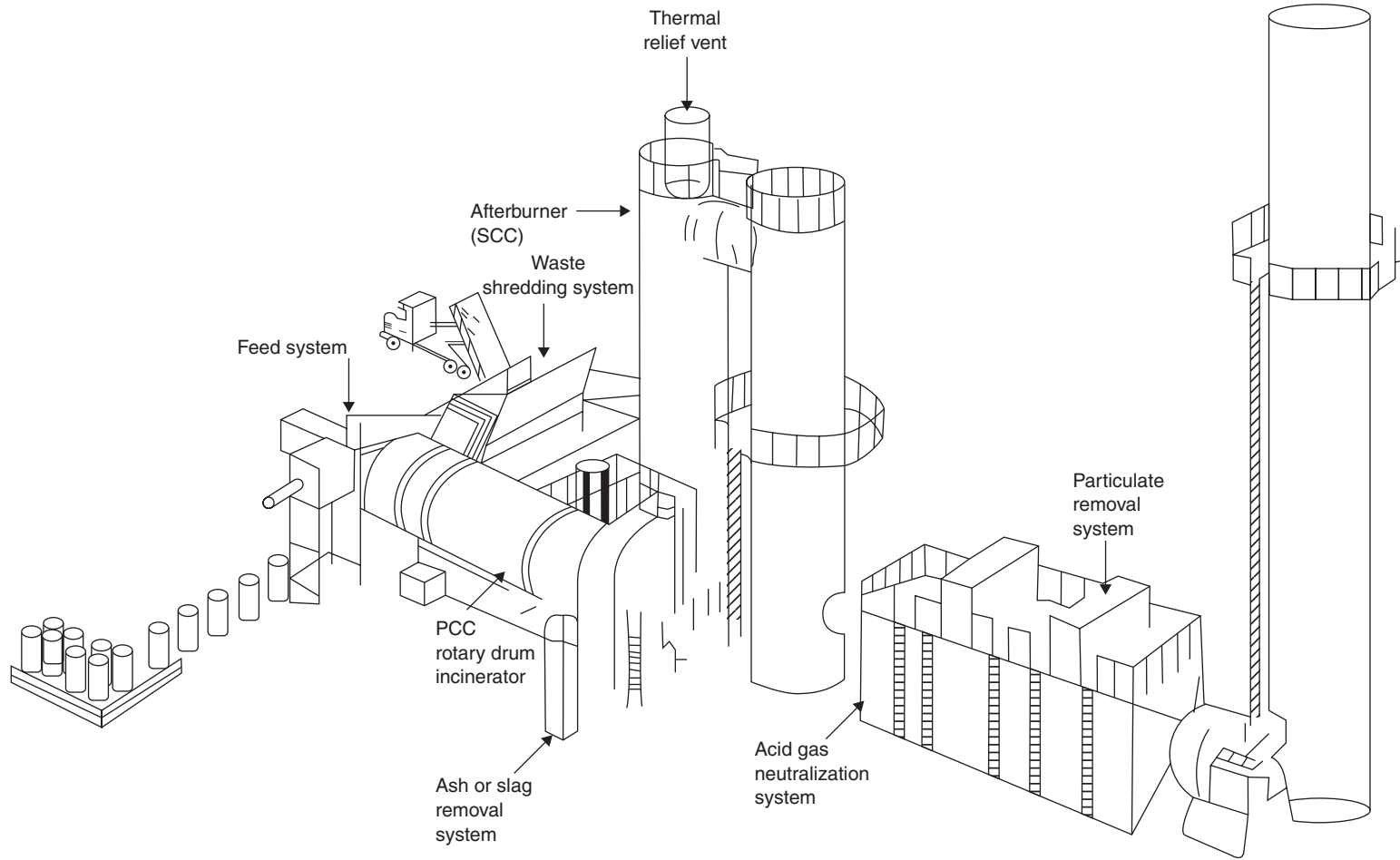

Figure 8.11 Rotary kiln incinerator (adapted from <http://www.energytek.com.tw/rk.htm>)

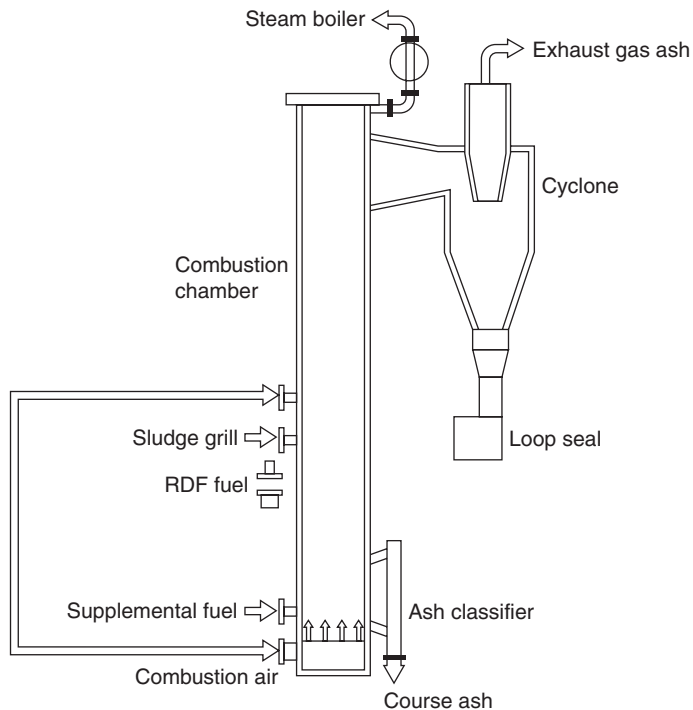

Figure 8.12 Fluidized bed furnace (adapted from http://www.nett21.gec.jp/JSIM_DATA/WASTE/WASTE_5/html/Doc_514.html)

one end and incineration, with complete combustion is at the other (<http://www.caldo.com/pyrolysis%20&%20gasification.htm>).

During the process, the feedstock is prepared and fed in either dry or slurried form into a sealed reactor chamber called a gasifier. The feedstock is subjected to high heat, pressure and either an oxygen-rich or oxygen-starved environment within the gasifier. Most commercial gasification technologies do not use oxygen. All require an energy source for heat generation and commencing the process (<http://www.ciwmb.ca.gov/Organics/Conversion/Gasification/>). The three basic gasifier designs include entrained flow gasifiers, fluidized bed gasifiers (Figure 8.13) and fixed bed (sometimes referred to as moving bed) gasifiers.

Thermal processes applications

Drying experiments of olive cake, a solid residue that is derived from the olive pressing (initial moisture content 45%, sample thickness 0.4, 0.6, 1.2 cm, sample sizes 150, 250, 500 g) were conducted in a cabinet-type dryer using ambient air at temperatures from 80 to 110°C and constant air velocity at 1–2 m/s. Then, the dried samples were cooled under laboratory conditions and packed in low-density polyethylene bags. It was found that for thin samples, moisture ratio decreases considerably with drying time due to the non-existence of a constant drying rate period. The rate of moisture loss was initially high; two-thirds of the time may be spent removing the last one-third

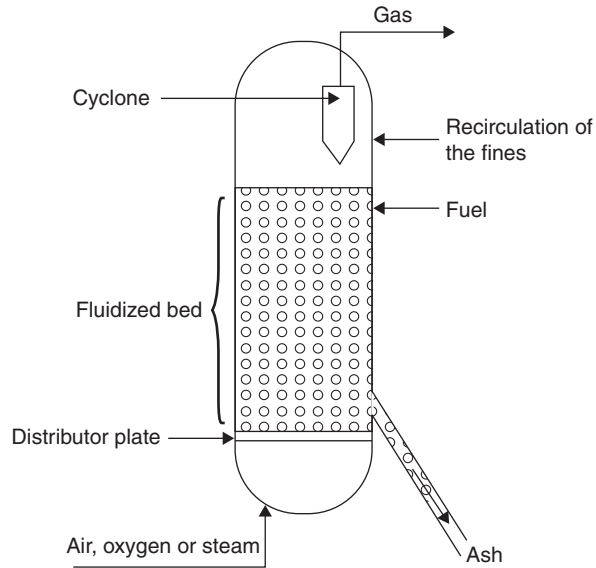

Figure 8.13 A fluidized bed gasifier (adapted from <http://www.fao.org/DOCREP/T0512E/T0512e0a.htm>)

of the moisture content. The rate of moisture loss was higher the higher the temperature and the total drying time decreased substantially with an increase in air temperature (Figure 8.14a). Figure 8.14b shows that an increasing sample thickness slows down the moisture adsorbed, thereby requiring longer to reach a certain moisture content. Similar results were obtained at all temperatures (Doymaz *et al.*, 2004).

A drying experiment of *alpeorujo* was conducted in a laboratory dryer at six different temperatures (50–350°C), two velocity levels (2 and 3 m/s) and four sample sizes. Two additional sets of experiments were carried out; the first were conducted with high moisture samples by adding water and the second with low moisture samples by inserting a thermocouple. The drying rate was shown to increase almost linearly with the inverse of sample diameter. Figure 8.15 shows that the drying rate increased almost linearly with the temperature at any moisture content for an 18.0 mm diameter sample dried with 2 m/s air velocity. Furthermore, the drying rate was more sensitive to temperature at high moisture contents than at lower moisture content. The small samples dried at high drying air velocity required less time to reach a specific moisture content than large samples dried at low drying air velocity. The final apparent moisture content was less than zero due to the release of volatile matter weighed as moisture (Arjona *et al.*, 1999).

The thermal behavior of two olive-oil residue samples (non-leached and water-leached olive-oil residue) was examined at three heating rates (10, 20, and 50°C/min) in dry air atmosphere from room temperature to 700°C using the technique of thermogravimetric analysis. The results confirmed that increasing the heating rate increased the thermal degradation rate, the residual weight at 700°C and the initial degradation temperature. The thermal degradation rate and the initial degradation temperature

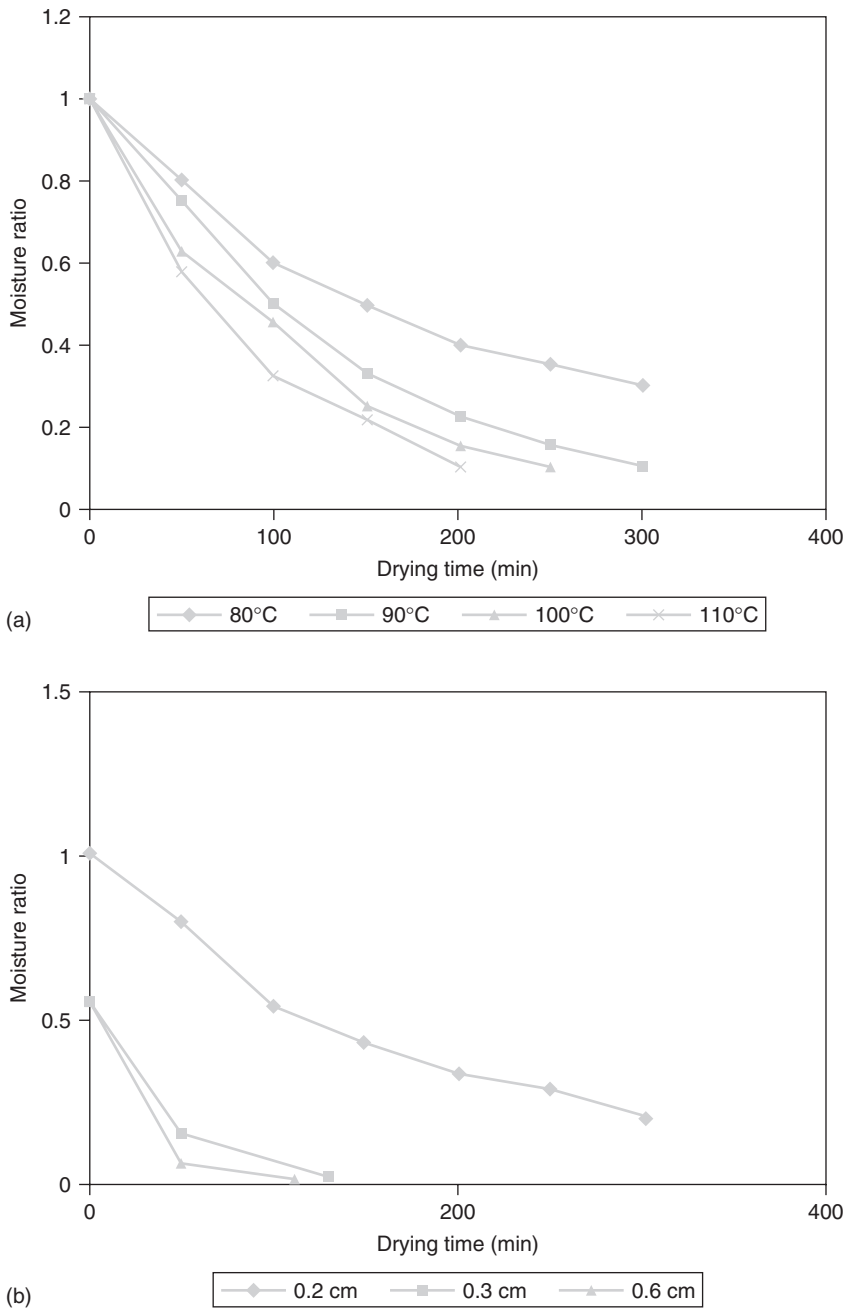

Figure 8.14 (a) Thin-layer drying curves of olive cake and moisture contents at different temperatures and several thickness (adapted from Doymaz *et al.*, 2004) (b) Moisture content at 80°C versus sample half thickness (adapted from Doymaz *et al.*, 2004)

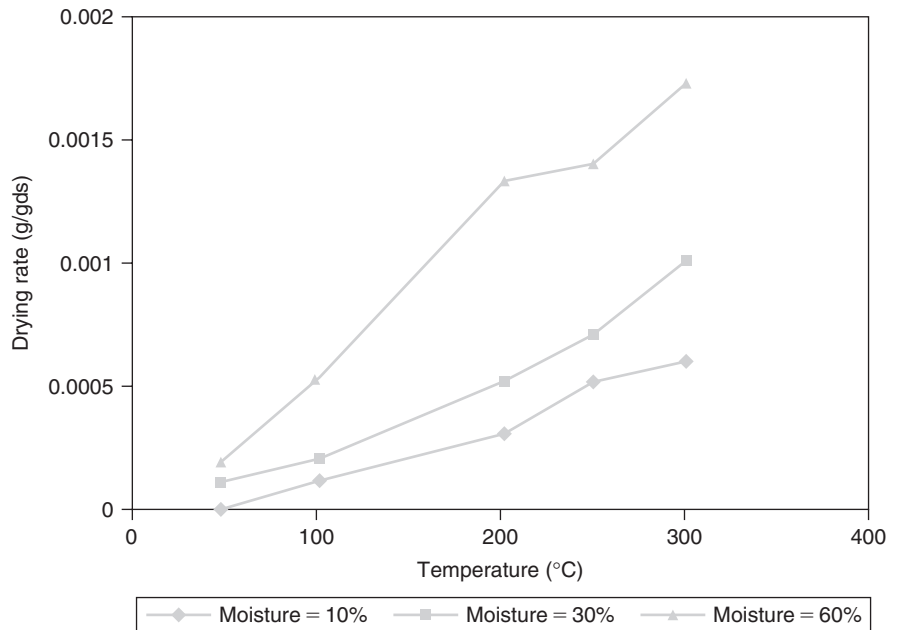

Figure 8.15 Drying rate versus temperature (adapted from Arjona *et al.*, 1999)

increased with the cellulosic content of the olive-oil residue, while higher ash content in the olive residue resulted in higher residual weight at 700°C (Garcia-Ibanez *et al.*, 2006).

Walid (2001) carried out an experiment in order to investigate the production of activated carbon from olive seeds by means of chemical activation. Olive cake was initially dried for 1 h at 100°C and the seeds were separated from the initial sample. Then carbonization was carried out in a closed crucible at various temperatures (400, 600, 800°C) for an hour. The final material was about 78% of the initial amount by volume and had higher adsorption capacity compared to the commercial type carbon. Olive seed activated carbon was shown to be more effective (at 800°C) than commercial type carbon, although the trends for olive seed activated and commercial carbon at various temperatures were the same. The adsorption capacity of regenerated carbon and other types of carbon was studied at 800°C. It was shown that the adsorption capacity of fresh activated carbon was higher than the others, followed closely by regenerated activated carbon and commercial type (Figure 8.16).

Olive seeds waste residue (crushed hard seeds and soft pulp) was immersed in water for 2 h in order to remove soft pulp particulates and the remaining hard fragments were dried in an oven at 105°C. In the oven, the samples passed through two distinct stages; the first stage was carbonization at 500–700°C under an inert temperature, while the second was activation with carbon dioxide. The residue of the process was a porous char. All samples produced were characterized by their absorptive capacities. An increase in adsorption capacity was obtained with higher activation time. It was shown that adsorptive capacities increased with increasing temperature

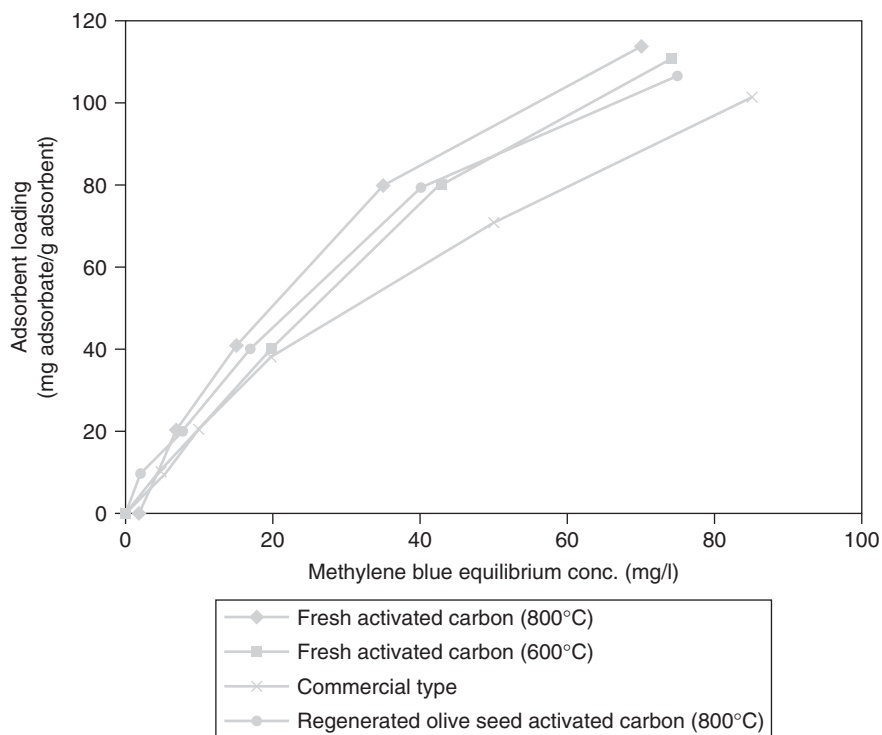

Figure 8.16 Adsorption isotherms for olive seeds activated carbon (at different temperatures) compared to regenerated olive seed and commercial activated carbon (adapted from Walid, 2001)

and they had low values at activation temperatures below 700°C (Figure 8.17). The results displayed less activation time with decreasing particle size. In fact, the products at diameter 355–500 μm and 500–710 μm showed higher adsorptive capacity than that of the commercial type. Iodine number tests, a reliable measure of adsorption quality, were also conducted to characterize the produced chars. It was found that the activation number increased with an increase in activation temperature and time. At temperatures above 800°C and 60 min, iodine number was shown to be considerably higher. On the other hand, iodine number decreased with an increase in particle size (Table 8.2). To sum up, the best conditions for activation were using particle size of 710–850 μm , at 800°C and for 90 min (Al-Khalid *et al.*, 1998).

Olive stones were fed into a reactor placed inside a sand-bath furnace under 1 MPa of inert gas and steam and heated at 500°C. Although the heat transferred from the furnace to the olive stones was rapid, the exothermicity of the pyrolysis made the solid heating occur at a higher rate, a minimum of 30°C/min heating rate was needed to initiate the foam formation and of 50°C/min for this to occur extensively. As the micro-pore volume of the foam was negligible, its low density (0.2–0.3 g/cm³) was due to the presence of mesopores and macropores, 60–80% of the pore volume corresponding to pores with a size superior to 1 μm (Rios *et al.*, 2006).

Vitolo and coworkers (1999) studied the vegetation waters (VWA) and olive husk coming from a traditional extraction process and vegetation waters (VWB) from a

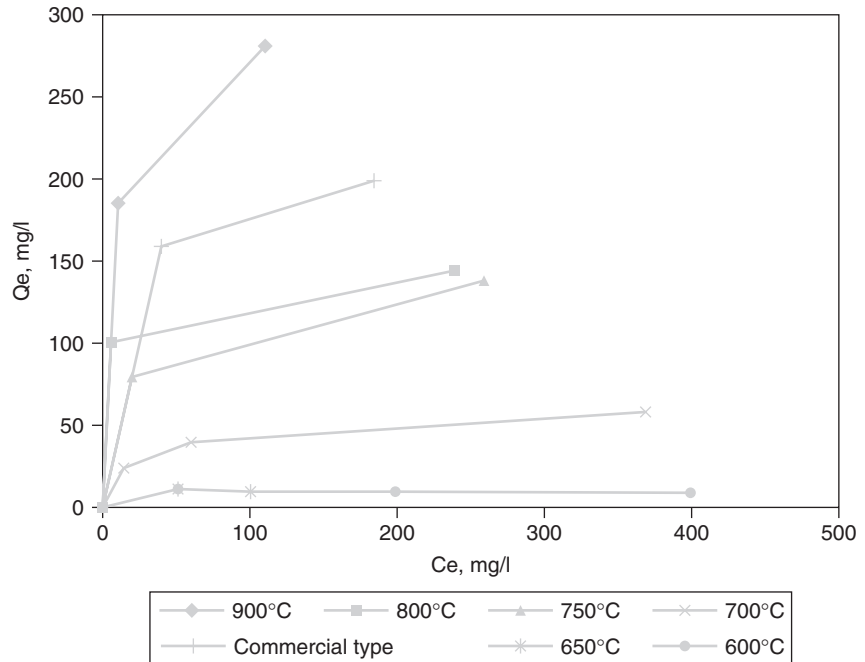

Figure 8.17 Effect of activation temperature on adsorptive capacity (activation period 60 min) (adapted from Al-Khalid *et al.*, 1998)

Table 8.2 Effect of activation temperature (60 min, 710–850 μm), time (800°C, 710–850 μm) and particle size (60 min, 800°C) on iodine number

Activation temperature(°C)	Iodine number	Time (min)	Iodine number	Average particle size (mm)	Iodine number
700	100	15	110	0.42	600
750	200	30	190	0.6	450
800	280	60	270	0.78	250
900	380	85	400	–	–

Adapted from Al-Khalid *et al.*, 1998

continuous extraction system. The VW were concentrated by evaporation and the condensed residues with the olive husk were both oven dried at 105°C before being pyrolyzed (200–550°C). The final products were char (solid residue), tar (heavy organic fraction), a liquid phase (oil and water) and an uncondensed gaseous fraction (CO₂, H₂, CO, CH₄, C₂H₆ from VW and CO₂, H₂, CO, CH₄ from olive husk). The VW residues and the olive husk could be effectively used as a fuel to provide heat in the evaporation stage.

OMW containing pieces of pit, pulp and vegetation water was pre-dried and then two mixtures OMW and coal (mixture A: 10% OMW and 90% coal; mixture B: 20% OMW and 80% coal) were co-fired in a fluidized bed combustor at temperatures ranging from

830 up to 940°C. It was found that mixture A gave lower CO emissions than 100% coal firing, whereas mixture B resulted in the highest CO emissions (Cliffe and Patumsawad, 2001).

Olive stones were used for the production of activated carbon. The sample was crushed and dried at 120°C. Then carbonization took place in a horizontal tube furnace heated from 25°C to 850°C at 20°C under a constant flowing N₂ atmosphere. Activation was carried out after carbonization at the same temperature and the final products were dried at 120°C for 4 h. The final products were endowed with high adsorptive capacity, particularly in the presence of an aqueous medium (El-Sheikh *et al.*, 2004).

Some agricultural and waste biomass samples (sunflower shell, pinecone, rapeseed, cotton refuse and olive refuse) were first pyrolyzed in nitrogen and then their chars were gasified in a gas mixture of steam and nitrogen. Pyrolysis of the biomass samples was performed from ambient to 1000°C in a dynamic nitrogen atmosphere of 40 cm³/min, while the produced chars were cooled to ambient temperature and then gasified up to 1000°C in a dynamic atmosphere of 40 cm³/min of a mixture of steam and nitrogen. The results showed that the gasification characteristics of biomass chars were dependent on the biomass properties such as ash and fixed carbon contents and the constituents present in the ash. Water desorption at lower temperatures, decomposition of hydroxide minerals to oxide minerals and formation of carbon monoxide at medium temperatures and production of hydrogen at high temperatures govern the behavior of the char during the gasification process. The chars from the olive refuse were not gasified satisfactorily. Low ash content and high fixed carbon content biomass materials are recommended for use in gasification processes when char from pyrolysis at elevated temperatures is used as a feedstock (Haykiri *et al.*, 2006).

Yaman *et al.* (2000) used olive refuse wastes (moisture content 7.5%) for fuel briquetting experiments. However, the produced briquettes were of low mechanical strength. The mechanical strength expressed as shatter index and compressive strength amounted to 330–468 and 1.5–3.3 MPa, respectively. Moreover, the properties of briquettes produced from a mixture of olive refuse and a fibrous material, such as paper mill waste were examined as well. Since these composites were sufficiently strong they could be effectively used as an energy source.

Steam explosion experiments were performed on olive stones (whole stones and seed husks fragments) under various conditions of temperature and time (2 min at 200–236°C for stones and 2–4 min at 200–232°C for seed husks), with previous acid impregnation. It was shown that hemicelluloses were converted into soluble carbohydrates and a considerable production of fermentable carbohydrates was recorded (Fernandez-Bolanos *et al.*, 2001).

Evaporation

Evaporation is the vaporization of a liquid from a solution or slurry and is applicable to liquids, slurries and sludges. These materials may contain liquids and/or suspended or dissolved solids, which are virtually non-volatile. After the liquid portion of the waste is evaporated, the waste volume is considerably reduced. Only the remaining residue is left for disposal as hazardous waste (<http://www.ecy.wa.gov/pubs/96414.pdf>). The goal of

this process is the water separation by using a multistage evaporation system enabling heat recovery. The concentrate from the evaporation process has to be treated before its disposal, generally by using biological treatments, such as aerobic digestion and an activated sludge process. Drawbacks consist of high energy demand, considerable air emissions and complex control processes requiring specialized personnel. In view of the high operational costs involved in evaporation, it is a suitable solution only for industrial-scale oil mills (Caputo *et al.*, 2003). Evaporators fall into two categories: batch and continuous. The application of evaporation can be classified under the headings of vaporization, concentration and crystallization.

Vitolo *et al.* (1999) concentrated vegetable waters from traditional batch mill and continuous mill by evaporation in a rotary evaporator under vacuum (50 mmHg pressure) or atmospheric pressure. The vapors were condensed and collected periodically in order to be examined. The COD reduction in the condensed vapors reached up to 98%, the organic load reduction in the residues was also up to 98% and an absence of polyphenols in the condensed vapors was reported as well.

Membrane processes

Membrane processing is a technique allowing for concentration and separation without resorting to thermal processes. Particles are separated on the basis of their molecular size and shape with the use of pressure and specially designed semipermeable membranes (<http://www.foodsci.uoguelph.ca/dairyedu/membrane.html>).

Membrane processes have been in use for more than 20 years in the food industry production processes and are continuously gaining ground in depollution techniques, particularly due to their ability to concentrate by-products of interest such as whey proteins, recycled paints and degreased baths in the mechanical engineering industries, retrieved precious metals or aromatic compounds, etc. (Nabi *et al.*, 2000). The concentration of solids in wastewater is a very interesting process. However, in spite of its advantages, membrane filtration it is not yet used in processes for low value products, i.e. municipal wastewater treatment. The main reason for this is the high energy demands that lead to high process costs (http://www.igb.fraunhofer.de/WWW/GF/Wasser/en/GFWM_211_MAR-Filtration.en.html). Various types of membrane separation processes have been developed for specific industrial applications. Some of the most widely used processes are reverse osmosis (RO), ultrafiltration (UF), nanofiltration (NF), microfiltration (MF), electrodialysis (ED), gas separation (GS) and pervaporation (PV). The characteristics of membranes used in different membrane separation processes, process driving forces and applications of such processes are shown in Table 8.3.

OMW were separated into five fractions on the basis of the molecular weight by UF and RO. All fractions were tested for toxicity on aquatic organisms from different trophic levels. It was found that the most toxic fraction was that from RO due to the presence of low molecular weight compounds (<350 Da), such as catechol and hydroxytyrosol (Fiorentino *et al.*, 2003).

Turano *et al.* (2002) carried out an experiment on OMW treatment consisting of a centrifugation step, in which suspended solids were removed, followed by UF of the centrifuge supernatant. The pretreatment of OMW (centrifugation) is necessary because

Table 8.3 The characteristics of membranes used in different membrane separation processes, process driving forces and applications of such processes

Process	Membrane type and pore size	Process driving force	Applications	Approx. market size (rs. In crores) 1999–2000
Microfiltration	Symmetric microporous, 0.05–10 μm	Hydrostatic pressure difference at approx. 10–500 kPa	Sterile filtration, clarification	200
Ultrafiltration	Asymmetric microporous, 1–50 nm	Hydrostatic pressure difference at approx. 0.1–1.0 MPa	Separation of macromolecular solutions	15
Reverse osmosis	Asymmetric skin-type, <1 nm	Hydrostatic pressure difference at approx. 2–10 MPa	Separation of salts and microsolute from solutions	80
Electrodialysis	Cation and anion exchange membrane	Electrical potential gradient	Desalting of ionic solutions	45
Gas separation	Asymmetric homogeneous polymer	Hydrostatic pressure and concentration gradients	Separation of gas mixtures	–
Pervaporation	A non-porous membrane	Vapor pressure gradient	Separation of azeotropic mixtures	–
Nanofiltration	Thin-film membranes, 2 nm	0.9–1.6 MPa	Removal of hardness and desalting	–

<http://www.tifac.org.in/offer/tlbo/memb.htm>; <http://www.tifac.org.in/news/memb.htm>

OMW causes severe fouling of the membrane thus affecting the UF process. Fouling reduces the permeate fluxes, thus resulting in both efficiency decrease and variation of membrane selectivity. Moreover, it makes the process highly and prohibitively expensive (Cheryan, 1986; Belfort *et al.*, 1994; Zeman and Zydney, 1996). COD reduction up to 90% and reduction of ashes and suspended solids up to 80% were reported.

Electrolysis

The theory of waste treatment by electrolysis is adding electric energy to waste thereby leading to electric reaction and waste purification. The first electric reactions, such as oxidation electrolysis, deoxidization electrolysis and neutral electrolysis, occur in boundary space between waste and electrode, whereas the second electric reaction, in which the elements of the waste and electrode products are reacting with each other, remove both organic (microorganisms and plankton) and inorganic (nitrogen and phosphorous) substances/elements (<http://edkme.dkme.com>). The process of electrolysis is applied in fields like electroplating, electrorefining and extraction of metals.

In recent years, an increasing interest has been shown in the use of electrochemical methods for the treatment of wastewaters (Comninellis and Pugarin, 1991; Comninellis, 1992, 1994; Comninellis and Nerini, 1995; Naumczyk *et al.*, 1996). Electrochemical methods were successfully applied in the purification of several industrial wastewaters (Kusakabe *et al.*, 1984; Sharifian and Kirk, 1985; Comninellis and Pugarin, 1991; Lin and Peng, 1994) as well as landfill leachate (Chang *et al.*, 1995) and domestic sewage (Della Monica *et al.*, 1980).

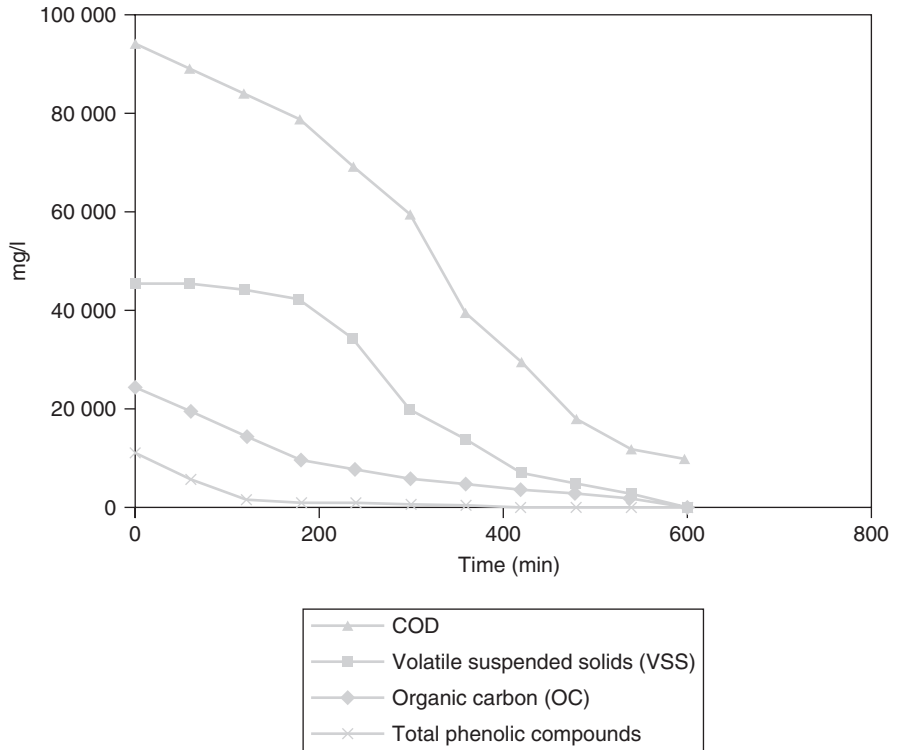

Figure 8.18 COD, volatile suspended solids (VSS), organic carbon (OC) and total phenolic compounds reduction during electrolysis (adapted from Israilides *et al.*, 1997)

An electrolysis system consisting of Ti/Pt as anode and stainless steel 304 as cathode was used for OMW treatment. In this technique, sodium chloride 4% (electrolyte) was added to the OMW at 42°C and the mixture went through the electrolytic cell. After 10 h of electrolysis, the soluble COD, volatile suspended solids (VSS), organic carbon (OC) and total phenolic compounds were reduced down to 93%, 98.7%, 80.4% and 99.4% respectively (Figure 8.18) (Israilides *et al.*, 1997). The results indicated that electrolysis could be employed as a pretreatment stage followed by chemical treatment or other advanced oxidation process (Israilides *et al.*, 1997; Azbar, 2004).

Ozonation

Ozonation is usually adopted for water disinfection, but it also has a high potential as a pretreatment method (Niaounakis and Halvadakis, 2006). Ozone, as the most powerful oxidizing reagent, is capable of degrading several phenolic compounds effectively, with the advantage that oxidized products are usually less toxic than the parental compounds (Rice, 1981). In oxidation systems by using ozone it is possible:

- 1 to convert inorganic components into higher oxidation stages
- 2 to cleave hardly biodegradable organic compounds

3 to kill bacteria

4 to destroy especially odorous, taste-causing and coloring substances.

With the help of UV radiation, the effect of both oxidizing agents can further increase by radical formation (Niaounakis and Halvadakis, 2006).

The ozonation process consists of steps, the first of which involves compressing air from the atmosphere and feeding this air through valves into a chamber containing pellets. The valves switch back and forth to vary the pressure in the chamber from alternating vacuum and pressure cycles. The air breaks down to separate nitrogen and oxygen with nitrogen merging with the pellets, leaving free O₂ that goes to an oxygen tank and is stored there until needed. The free O₂ progresses to an ozone generator, where the electric current is used to charge the O₂ to reform as O₃ charged molecules with electricity. The O₃ is then applied to the wastewater where it violently disinfects the water and dissipates in it. The wastewater is further subjected to traditional water treatment, such as filtration and chlorination, with any excess ozone recycled to the inlet water where it joins the water system (http://www.iconpr.com/news/news_see.cfm?inv_id=190-1).

Phenolic acids constitute an important group of pollutants recalcitrant to biological treatment. Solutions containing a mixture of cinnamic acid, *p*-coumaric acid, caffeic acid and ferulic acid were submitted to ozonation. Then the changes in biodegradability along the process were studied by means of respirometry. There is an optimum ozone dosage in the interval 3–5 min of treatment which allows achievement of the maximum increase in biodegradability (more than 10 times) and a high efficiency of the ozonation process (COD decreases to a half of its initial value). Further ozonation does not increase the biodegradability and is clearly disadvantageous. Similar results were obtained with actual samples of olive oil wastewaters. This behavior was explained by the formation of highly biodegradable benzaldehydes as key ozonation intermediates in the early reaction stages (Amat *et al.*, 2003).

Experiments of *p*-hydrobenzoic acid degradation with ozone were carried out in a batch reactor at different temperatures (10, 20, 30 and 40°C), pH (2, 5, 7 and 9) and ozone partial pressure (0.10–0.39 kPa). An increase in ozone partial pressure, pH and temperature showed greater phenolic acid degradation (Benitez *et al.*, 2000).

The degradation by ozone of seven phenolic acids (caffeic, *p*-coumaric, vanillic, 3,4,5-trimethoxybenzoic, veratric, *p*-hydroxy-benzoic and protocatechuic) in a semi-continuous reactor at different temperature (10–40°C), pH (2–9) and ozone partial pressure (0.25–0.79 kPa) was examined by Benitez *et al.* (1997). Temperature, pH and ozone partial pressure were correlated with phenolic acid degradation. The order of acids degradation is the following: caffeic > *p*-coumaric > vanillic > 3,4,5-trimethoxybenzoic = veratric > *p*-hydroxy-benzoic > protocatechuic.

Digestion

Digestion is the enzymatic breakdown of large insoluble organic molecules into small soluble organic molecules which can be absorbed and used by either aerobic or anaerobic microorganisms (<http://www.oasisenviro.co.uk/Glossary%20C%20to%20E.htm#desorption>).

Aerobic digestion of waste is the natural biological degradation and purification process in which bacteria thriving in oxygen-rich environments break down and digest the waste. During this oxidation process, pollutants are broken down into carbon dioxide (CO₂), water (H₂O), nitrates, sulfates and biomass (microorganisms). By optimizing the oxygen supply with so-called aerators, the process can be considerably accelerated (<http://www.biotank.co.uk/aerobic.htm>).

Anaerobic digestion is a biological process in which organic material is broken down by microorganisms. Unlike composting, the process occurs in the absence of air (<http://www.colebrand.com/wastad.htm>). The main products of anaerobic digestion are methane, carbon dioxide and undegraded solids and liquids (<http://www.biogasworks.com/Reports/9th-yt&t.htm>). The residue remaining after digestion can be used as a soil conditioner. The process also generates a gas which can be used as a fuel either for domestic or industrial use (<http://www.colebrand.com/wastad.htm>).

All anaerobic digesters consist of the following basic components: feedstock storage and handling system, digestion tank and gas and residue recovery systems. In an anaerobic digestion plant, there are two types of anaerobic digestion process: mesophilic and thermophilic digestion (http://www.europa.eu.int/comm/energy_transport/atlas/htmlu/adint.html). The type of digester to be used greatly depends upon the waste type availability and the waste collection method. There are essentially three types of digester designs: covered lagoon, complete-mix and plug flow digesters.

The olive-oil-producing countries are trying to face the negative impacts of the olive oil wastewaters in the environment. The most promising and effective of these attempts is the anaerobic treatment of olive oil wastewater for the production of methane (Dalis *et al.*, 1982; Fiestas Ros de Ursinos, 1982; Aveni, 1983; Boari *et al.*, 1984; Rozzi *et al.*, 1984; Aveni and Lamarca, 1986; Dalis, 1991; Georgacakis and Dalis, 1993) or for the recovery of valuable materials. The wastewater can also be used as a soil-quality recovered and as liquid fertilizer (Balice, 1990) (Figure 8.19).

Anaerobic treatment of olive oil mill wastes, namely black water and prina, was investigated by Ergüder *et al.* (2000) in batch reactors. Biochemical methane potential (BMP) tests were conducted to determine the anaerobic biodegradability of black water and/or prina. With these BMP tests, the biodegradability of OMW at different initial COD concentrations and corresponding methane gas productions were investigated. Furthermore, a screening study was performed to determine the most important nutrients for the anaerobic digestion of black water. The results indicated that OMW could be anaerobically treated with high efficiency (85.4 up to 93.4%) and treatment of 11 OMW by anaerobic methods resulted in production of 57.1 ± 1.5 l of methane gas; anaerobic treatment of the olive mill residual solids (OMRS) alone was poor, however, when OMRS was mixed with OMW in certain ratios, OMRS could be treated efficiently under anaerobic conditions. Anaerobic cultures needed an adaptation period of 15–25 days for treatment of OMRS with or without OMW.

Dalis and coworkers (1996) designed an anaerobic digestion system consisting of a storage tank, an up-flow sludge-blanket reactor and a fixed bed-type reactor in series and filled it with raw OMW. The raw OMW was mixed with anaerobic biomass and added to the up-flow reactor followed by a fixed bed reactor. Seven consecutive experiments were conducted and the temperature was kept at $35 \pm 1^\circ\text{C}$ in both digesters. In the up-flow

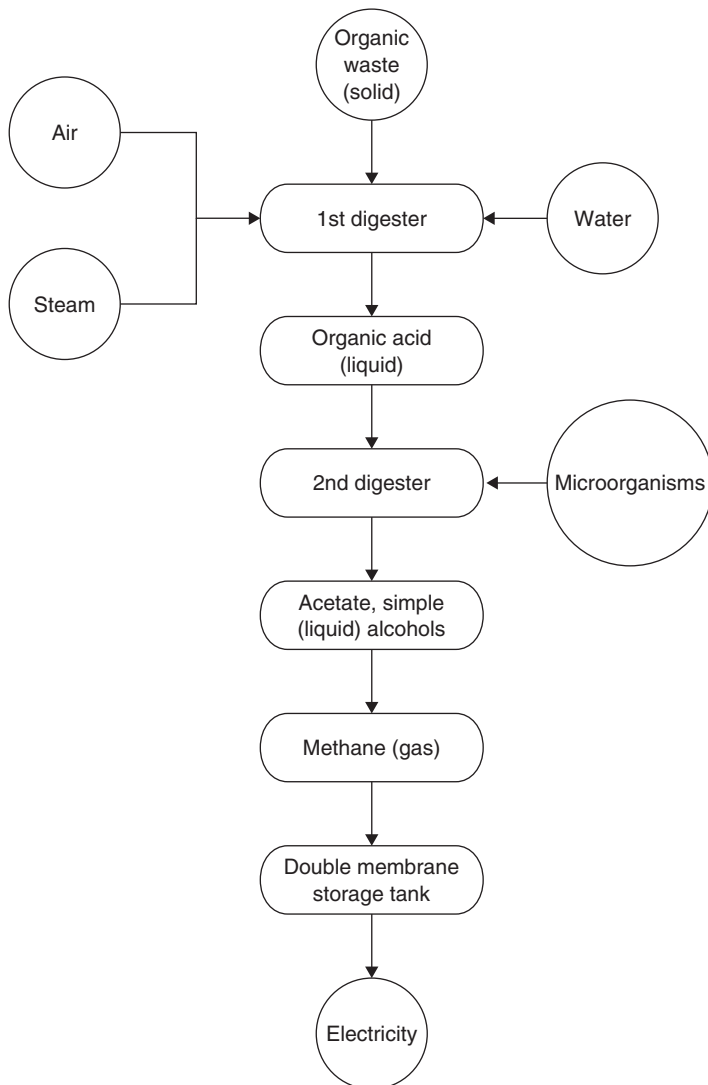

Figure 8.19 Anaerobic digestion of organic waste (adapted from http://www.mrc.wa.gov.au/resources/anaerobic_digestion.html; Arvanitoyannis *et al.*, 2007)

digester (first experiment), a satisfactory reduction was obtained in total organic carbon (TOC), COD, phenols and volatile acids amounting to 68–78%, 75–85%, 73% and 75%, respectively (Figure 8.20). The fixed bed digester showed a further TOC and COD reduction amounting to 15–20%, whereas for phenols the reduction was up to 35% and volatile acid degradation reached 45% (Figure 8.21). In the up-flow digester a slight increase of the specific biogas production was recorded which fluctuated from 2.11 biogas/l digester per day, while in the up-flow digester the biogas production was stabilized at 0.51 biogas/l digester per day. In the up-flow digester the specific biogas yield during the second and the third experiments ranged between 2 and 221 biogas/TOC degraded. In the fixed bed

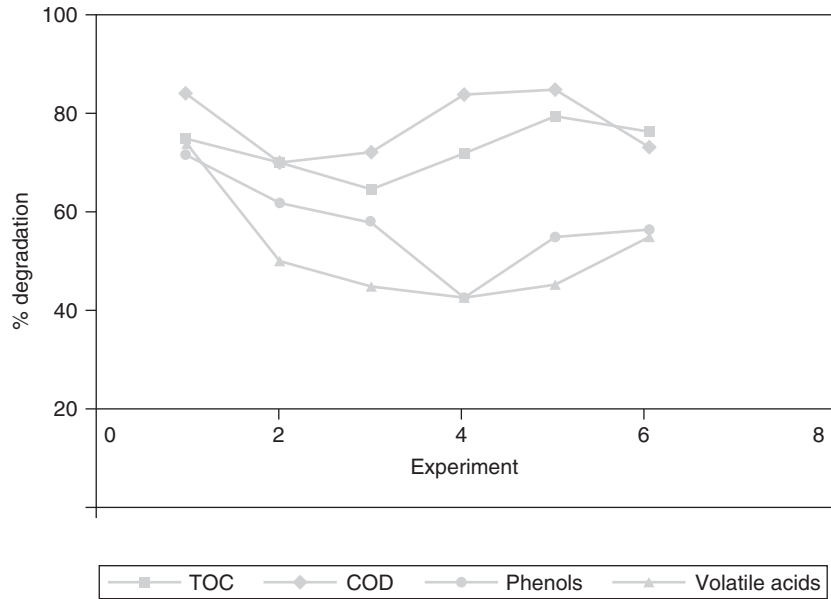

Figure 8.20 Percentage TOC, COD, phenols and volatile acids degradation in the up-flow digester in steady state conditions (adapted from Dalis *et al.*, 1996)

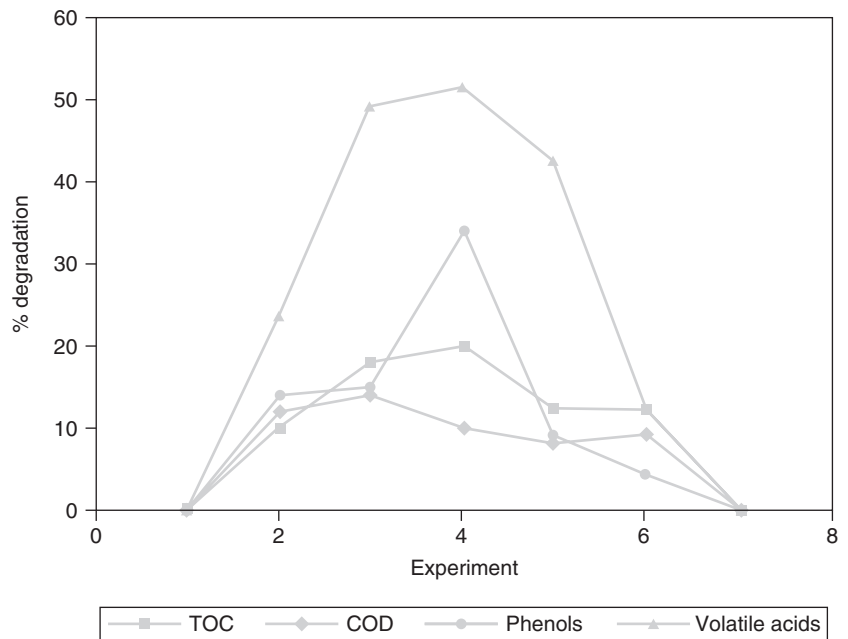

Figure 8.21 Percentage TOC, COD, phenols and volatile acids degradation in the fixed bed digester in steady state conditions (adapted from Dalis *et al.*, 1996)

digester, the maximum specific biogas yield (1.51 biogas/TOC degraded) was observed during the second and the sixth experiments.

In another experiment by Borja *et al.* (1996), a hybrid anaerobic reactor consisting of a sludge blanket (one-third) and submerged clay rings (two-thirds) was fed with OMW under mesophilic conditions (35°C). A COD reduction higher than 89% was reported and biogas production with methane content varied between 69 and 75% throughout the experiment.

Crude OMW was pretreated with *Phanerochaete chrysosporium* and then transferred to an anaerobic filter reactor at 37°C. The OMW pretreatment caused COD reduction up to 50% in a week, degradation of low molecular weight aromatics, depolymerization of high molecular weight compounds, while there was no decolorization. During the anaerobic digestion of pretreated OMW, inhibition of the biomethanation process was reported (Gharsallah *et al.*, 1999).

Coagulation/flocculation/precipitation

Precipitation is the chemical conversion of soluble substances (including metals) into insoluble particles. Coagulation and flocculation initiate a chemical reaction that promotes the formation, agglomeration or clumping of such particles thereby facilitating their removal from solution (http://www.waterspecialists.biz/html/jar_test.html). Coagulation and flocculation processes are an important part of water and wastewater treatment and have been practiced worldwide for almost a century (<http://www.ec.njit.edu/~hsieh/ene670/coagula.html>).

Electrocoagulation is a process in which an electrical field is applied across a water stream thereby initiating a chemical reaction (<http://www.watertreatmentteam.com/electrocoagulation%20applied.htm>). The coagulant is generated *in-situ* by electrolytic oxidation of an appropriate anode material (<http://www.eco-web.com/cgi-local/sfc?a=/editorial/index.html&b=/editorial/06053.html>). When applied to waters contaminated with a wide variety of inorganics, this reaction induces the inorganics to combine in a strong molecular bond with ions released from the base metal in the reactor. These new molecules are large and are removed from the effluent with standard solids separation technologies (<http://www.watertreatmentteam.com/electrocoagulation%20applied.htm>).

The presence in OMW of hardly or non-biodegradable dissolved organic pollutants, mainly tannic acid, requires the employment of chemical-physical treatments, such as adsorption, precipitation and flocculation characterized by the addition of chemicals (activated carbon, poly-electrolytes and flocculants respectively) (Caputo *et al.*, 2003).

Meyssami and Kasaeian (2005) added coagulants such as chitosan, starch, alum and ferric chloride to olive oil-water emulsions which were then transferred to an air flotation system. The objective of their experiment was the separation of coagulated oil droplets from suspension. It was shown that ferric chloride and starch were not effective coagulants, while alum (main coagulant) and chitosan (coagulating aid) were effective in reducing primary turbidity of the emulsions (90%). At optimized

conditions of coagulation and flotation stages (100 ppm chitosan, airflow 3 l/min, aeration time 45 s, 20°C, pH 6), the COD reduction reached up to 95%.

Effluents from two-phase and three-phase olive mills were treated by means of direct flocculation (without prior coagulation) using four cationic and two anionic poly-electrolytes. Moreover, lime and ferric chloride were used as reference coagulants and compared with poly-electrolytes. Three cationic and one anionic poly-electrolytes were shown to be capable of removing total suspended solids (TSS) and reducing COD and biological oxygen demand (BOD) when applied at minimum dosage (2.5–3 g/l). However, the remaining poly-electrolytes were not appropriate for olive mill effluents treatment even at high dosages (7 g/l). In comparison with lime and ferric chloride, it was found that they were capable of removing TSS but did not cause any COD reduction (Sarika *et al.*, 2005).

A laboratory-scale reactor for electrocoagulation was filled with raw OMW. The reactor voltage was 10 V, current density 10–40 mA/cm, pH 4, 6, 7, 9, temperature 21–22°C and Al, Fe electrodes (Al/Fe in one case and Fe/Al in another case) respectively. A 20% COD removal was recorded at 2 min, while at 30 min the COD removal remained at 42% level, with optimal time for OMW treatment at 10–15 min (as anode). At 2 min retention time, the minimal percentage of color removal was 78%, while at 10–30 min, the color removal remained at 96% level, with optimal time for OMW treatment at 10 min (taken as anode). At 2–10 min, the suspended solids (SS) removal increased from 48 to 68% (as anode). At 2 min, a 28% COD removal was observed, higher than Fe electrode, while at 30 min, the COD removal remained at 52%, with optimal time for OMW treatment at 10–15 min (as anode). At 2 min retention time, the minimal percentage of color removal was 82%, while at 10–30 min the color removal remained at 96% level, as Fe electrode, with optimal time for OMW treatment at 10 min (taken as anode). At 2–10 min, the SS removal increased from 48 to 68% (as anode) (Figure 8.22) (Inan *et al.*, 2004).

Adhoum and Monser (2004) carried out an electrocoagulation experiment using sacrificial aluminum electrodes in an attempt to investigate the removal of COD, polyphenols and dark color of fresh and stored OMW. The optimum conditions for OMW treatment were: current density 75 mA/s, 25 min and pH 4–6. In fresh OMW, COD reduction and polyphenols removal were reported at 75.8 and 91.4%, respectively, while color reduction was higher than 95%. In stored OMW, COD and polyphenols showed removals of 71 and 93%, while color reduction was more than 95% (Figure 8.23).

Distillation

Solar distillation is the process of distilling (purifying) water using solar energy (http://www.daviddarling.info/encyclopedia/S/AE_solar_distillation.html). In this process, a solar collector is used to concentrate solar energy to heat the feedwater so that it can be used in the high temperature end of a standard thermal desalination process (<http://www.unep.or.jp/ietc/publications/techpublications/techpub-8d/desalination.asp>). The solar energy heats water to the point of evaporation. As the water

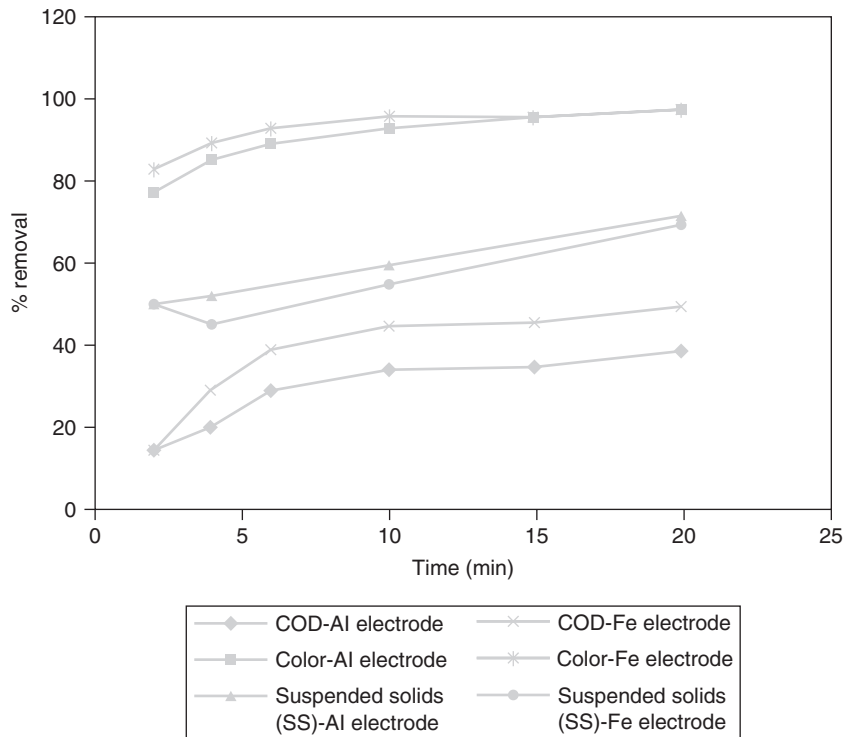

Figure 8.22 COD, color and suspended solids (SS) removal (%) for Al and Fe electrode (pH 6.2, current density 20 mA/cm) (adapted from Inan *et al.*, 2004)

evaporates, water vapor rises, condensing on the glass surface for collection. This process removes impurities such as salts and heavy metals as well as eliminating microbiological organisms. The end result is water much cleaner than the purest rain-water (<http://www.solaqua.com/solstilbas.html#ssback>). These units require a capital investment and specialized personnel to operate them over a long period of time. Moreover, additional energy input to pump the water through the process is required (<http://www.unep.or.jp/ietc/publications/techpublications/techpub-8d/desalination.asp>). Recently, solar radiation was used in a number of applications for dewatering of wastewater in order to reduce the original volume and thus render the remaining sludge appropriate for further manipulation and treatment (Potoglou *et al.*, 2003).

An outdoor solar still, consisting of a liquid basin and a glass cover, was constructed for the treatment of OMW. The OMW was left inside the solar still for 9 days at ambient temperatures. The produced distillate was free from solids, had 80% lower COD and 90% lower TKN. In the basin, the residual was in solid form with 15% water concentration and no odor emissions were observed (Potoglou *et al.*, 2003).

Table 8.4 provides a synoptical presentation of the most important olive oil waste treatment methods (parameters, quality control and results). The advantages and disadvantages of various methods for olive oil waste treatment are presented in Table 8.5.

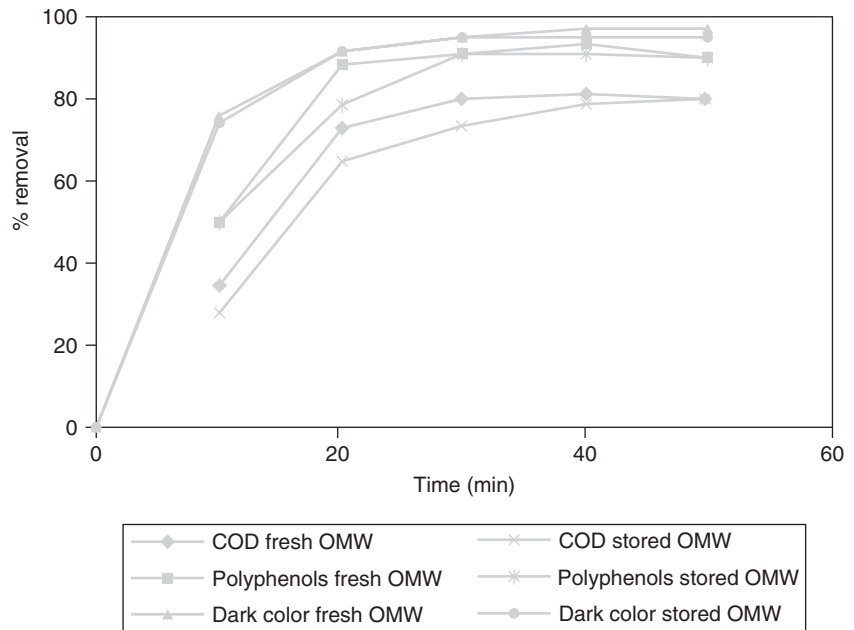

Figure 8.23 Polyphenol, COD and color removal rates from fresh and stored OMW (adapted from Adhoum and Monser, 2004)

Uses

The olive oil industry continues to be one of the most heavily polluting among the food industries. The plethora of olive oil waste uses (either currently ongoing or having potential in the future) are the following: fertilizer, biodiesel, activated carbon, briquette production, dye removal from wastewater, phenols (antioxidant activity).

Fertilizer/amendment

OMW contain high concentrations of inorganic and organic compounds (Pacífico, 1989; Arienzo and Capasso, 2000) and possess highly polluting properties documented by high COD and biological oxygen demand (BOD) (Arienzo and Capasso, 2000), due to their polyphenol content in conjunction with other naturally occurring compounds (Capasso, 1997). However, OMW may also be considered an inexpensive source of inorganic and organic compounds (Pacífico, 1989). Recycling of OMW as an amendment in agriculture, either in raw form or after having undergone various treatments (García-Barrionuevo *et al.*, 1992; Saviozzi *et al.*, 1993; Vlyssides *et al.*, 1996; Paredes *et al.*, 1999; Sayadi *et al.*, 2000) and recovery of their organic components

Table 8.4 Treatment methodologies of olive oil mills wastewaters; parameters, quality control and results

No	Kind of waste	Treatment	Parameters	Methodology	Quality control methods	Results	References
<i>A. Bioremediation</i>							
1	Wastewater	Bioremediation	COD, total phosphorus, chloride, metals, sugars and amino acids	Culture of <i>Azotobacter vinelandii</i> in OMWW	1 Spectrophotometer for O ₂ and phosphorus 2 Ion chromatography/ conductivity detection for chloride 3 Atomic absorption spectrometer for metals 4 HPLC for sugars and amino acids	1 COD reduction (70%) after 3 days 2 Total P remained stable 3 N increase 4 Decrease in phenolic compounds (100%) after 7 days 5 Sugars degradation after 3 days	Piperidou <i>et al.</i> , 2000
2	Wastewater	Removal of phenolic compounds	TSS, MSS, VSS, COD, TOC, CO ₂	Inoculation of <i>Phanerochaete chrysosporium</i> , <i>Aspergillus niger</i> , <i>Aspergillus terreus</i> and <i>Geotrichum candidum</i> followed by fermentation	1 According to the recommendation of American Public Health Association (APHS) for TSS, MSS, VSS, COD 2 Difference between TSS and MSS for VSS 3 Dohramann DC-190 carbon analyzer for TOC 4 IR spectroscopy for CO ₂	1 Highest removal of total phenols aerobically by <i>Phanerochaete chrysosporium</i> up to 100% 2 Highest COD reduction aerobically by <i>Phanerochaete chrysosporium</i> up to 75%	Garcia-Garcia <i>et al.</i> , 2000
3	Wastewater	Biodegradation of phenols with microorganisms	COD, pH, solids, phenols	Culture of <i>Geotrichum</i> spp., <i>Aspergillus</i> spp. and <i>Candida tropicalis</i> in wastewaters	1 Device measurement of O ₂ 2 Method Folin-Ciocalteu for phenol measurement	1 Lower phenols about 44.3–1.7% 2 Lower COD about 52.5–62.8%	Fadil, 2003
4	Wastewater	Biodegradation of phenols with microorganisms	COD, phenols	Culture of <i>Candida tropicalis</i> YMEC14 in wastewaters	1 Device measurement of O ₂ 2 Chromatography for phenols 3 Electronic microscope (SEM) for solids	1 Lower COD about 69.7% 2 Lower polyphenols about 55.3% 3 Lower monophenols about 69.2%	Ettayebi, 2003
5	Wastewater	Dephenolization	Phenols, COD	Use of polyphenol-oxidase or laccase for the enzymatic removal of	1 HPLC for phenols 2 Commercial colorimetric kit for COD	1 <i>Olive husk</i> : removal of low-molecular phenolics more than 90% and minor	Greco <i>et al.</i> , 1999

(Continued)

Table 8.4 (Continued)

No	Kind of waste	Treatment	Parameters	Methodology	Quality control methods	Results	References
				low-molecular phenolics in OMW		reduction of phenolic COD 2 <i>Laccase</i> : less effective in phenol removal	
6	Wastewater	Decoloration of wastewaters	Transmittance measurements	Aluminum sulfate lime (CaO) and hydrogen peroxide (H ₂ O ₂)	Spectrophotometer (Spectronic 20, Bausch and Lomb) wavelength 395 nm	Decoloration 15–50%	Flouri <i>et al.</i> , 1996
7	Wastewater	Metabolization of lipids and polyphenols	COD, polyphenols, citric acid	Strains of <i>Yarrowia lipolytica</i> in OMW	1 Association of Official Analytical Chemists (AOAC) methods for COD 2 Method of Folin-Ciocalteu's phenol reagent for polyphenols (Garcia-Garcia <i>et al.</i> , 2000) 3 HPLC for citric acid	1 COD reduction (1.47–41.22%) 2 Polyphenols reduction 3 Production of citric acid, lipase and biomass	Lanciotti <i>et al.</i> , 2004
8	Wastewater	Decoloration and biodegradation using microorganisms	Phenols, color, COD	Treatment with basidiomycetes <i>Phanerochaete chrysosporium</i>	1 A device for the measurement of O ₂ 2 Method Folin-Ciocalteu for phenol measurement	1 Lower phenols 90% 2 Decoloration 73% 3 Lower COD 45%	Dias <i>et al.</i> , 2004
9	Wastewater	Fermentation	Carbohydrates, N, P, fat, COD, metals, phenols, proteins, lipase, volatile compounds	Inoculation of <i>Yarrowia lipolytica</i> and fermentation (30°C, aeration 0.5 l/min, 500 rpm)	1 HPLC for carbohydrates 2 Association of Official Analytical Chemists (AOAC) methods for N, P, fat, metals 3 Folin-Ciocalteu method for phenols 4 Lowry method for proteins 5 Titration of fatty acids with alkali for lipase 6 GC for volatile compounds	1 COD reduction 80% in 24 h 2 Biomass production 22.5 g/l in 20 h 3 Lipase production 770 U/l in 20 h 4 Absence of fat and sugars	Scioli and Vollaro, 1997

10	Wastewater	Decolorization of phenolic compounds in fresh and stored OMW	COD, polyphenolic compounds	Aerated batch bioreactor with <i>Geotrichum candidum</i>	<ol style="list-style-type: none"> 1 Knechtel method for COD 2 Gel filtration on Sephadex G-50 for polyphenolic compounds 	<ol style="list-style-type: none"> 1 <i>Fresh OMW</i>: pH decrease, 50% COD reduction, 75% color removal 2 <i>Stored OMW</i>: 25% COD reduction, no decoloration, pH and oxygen increase 	Assas <i>et al.</i> , 2002
11	Wastewater	Increase in polyphenols	Polyphenols	Treatment with <i>Lactobacillus plantarum</i>	HPLC	Increase of polyphenols ($\times 7$)	Kachouri and Moktar, 2003
12	Solid fraction wastewater and olive leaves	Composting	TN, TOC, lignin, cellulose, fat, OM	Static pile system (Rutgers): 55°C, ventilation 30 s/ 15 min	<ol style="list-style-type: none"> 1 Automatic microanalysis for TN, TOC 2 American National Standard methods (ANSI/ASTM 1997) for lignin, cellulose 3 Soxhelt system for fat 4 Ignition at 430°C for 24 h for OM content 	<ol style="list-style-type: none"> 1 <i>Mixture A</i> (65% FOMW + 35%OL): biological activity and degradation organic matter (64%), lignin and cellulose (60%), fat 2 <i>Mixture B</i> (74% FOMW + 25%OL + 1%urea): biological activity and degradation organic matter (40%), lignin and cellulose (38–39%), fat 	Garcia-Gomez <i>et al.</i> , 2002b
13	Insoluble wastewaters	Biodegradation of insoluble wastewaters	pH, COD, phenols	Use of <i>Penicillium</i> (P4 stipe)	<ol style="list-style-type: none"> 1 Measurement of COD according to American Public Health Association (APHA) 2 Method Folin-Ciocalteu for phenol measurement 	<ol style="list-style-type: none"> 1 Lower saccharose – phenols 54.5% 2 Increase in pH because of decrease of organic acids 3 Lower COD 61% 	Robles <i>et al.</i> , 2000
14	Olive marc and wastewater	Composting	TOC, TN, organic cellulose and hemillulose, total lipid content	Pile with olive marc, wheat straw and wastewater (1 year)	<ol style="list-style-type: none"> 1 Anne's method for TOC 2 Kjeldahl method for TN 3 Initial and final ash contents 4 Browning method for lignin, cellulose and hemillulose 5 Extraction with diethyl ether for 	Decrease in organic matter and C/N, organic matter losses higher the first 3 months, less degradation of lignin than cellulose and hemillulose, decrease of phenol (66%) and lipids (97%), increase	Baddi <i>et al.</i> , 2003

(Continued)

Table 8.4 (Continued)

No	Kind of waste	Treatment	Parameters	Methodology	Quality control methods	Results	References
					total lipid content	in N and ash content, can be used as fertilizer or amendment	
15	Standard wastewater solution	Removal of phenols	Phenols, COD	Culture of fungus <i>Pleurotus ostreatus</i>	Spectrophotometer for COD	Lower phenols 50–80%	Aggelis <i>et al.</i> , 2003
16	Wastewater	Decolorization and detoxification	Color and aromatic compounds, glucose, toxicity	Bioreactor with white rot fungus <i>Phanerochaete flavidobrunnea</i>	1 Absorbance measurement at 440 nm for color and 280 nm for aromatic compounds 2 YSI 2000 enzymatic analyzer for glucose 3 Microtox system for toxicity	Degradation of aromatic compounds (51.7%), reduction of color (70.3%) and toxicity (70%)	Blaquez <i>et al.</i> , 2002
17	Treated wastewaters	Degradation of phenols	Phenol-toxicity index, measurement of laccase	Treatment with stripes of <i>Pleurotus</i> spp	1 Method Folin-Ciocalteu for phenol measurement 2 Measurement of laccase with chromogenic substrate	1 Lower total phenols 2 Emergence of new more toxic complexes	Tsioulpas <i>et al.</i> , 2002
18	Wastewater (alpechin)	Enzymic biotransformation of the phenolic compounds	Phenol content	Bacterium <i>Bacillus pumilus</i> 123 (acting as a phenol-oxidizer)	Using cinnamic acid as an internal reference by HPLC	Decrease of phenols at diluted alpechin (concentrations: 40–100%), at concentration 80% generation of new phenolic compounds and slight reduction in total phenols	Ramos-Cormenzana <i>et al.</i> , 1996
19	Solid residue	Enzymatic saccharification	Crude cellulose, parental compounds (cellulose, hemicellulose, lignin), saccharides, glucose, enzymatic activity of <i>T. reesei</i>	Alkaline pretreatment (100°C, NaOH) followed by enzymatic saccharification with the <i>Trichoderma reesei</i> enzyme (5°C, pH 5)	1 SO-AFNOR norm for crude cellulose 2 Fractionating into NDF, ADF, ADL for cellulose, hemicellulose, lignin 3 DNS standard test for saccharides	Maximum saccharification yield (50%) at optimum experimental conditions	Abdi <i>et al.</i> , 2000

20	Wastewater	Decolorization	COD, color, polyphenols, enzyme activity	Growth of <i>Pycnoporous coccineus</i> , <i>Pleurotus sajor caju</i> , <i>Corioloipsis polyzona</i> , <i>Lentinus tigrinus</i> in OMW (fungal lignolytic enzymes) at 4 different COD values (25, 50, 75, 100)	4 Glucose-oxidase/ peroxidase enzymatic technique for glucose 5 Mandels-Andreotti method for enzymatic activity of <i>T. reesei</i>	1 Knechtel method for COD 2 Absorbance at different wavelengths for color 3 Size exclusion chromatography for polyphenols 4 Ligninolytic enzymes activity: veratrylic alcohol as substrate for LiP and with vanillylacetone for MnP. Laccase activity measured using ABTS according to Lonergan and Baker (1995)	1 Decolorization and COD removal at 50–75 g/l COD in OMW by all fungi 2 At 100 g/l COD effective only <i>Pycnoporous coccineus</i> , <i>Pleurotus sajor caju</i> 3 At 50 g/l COD decolorization (75%) by <i>Corioloipsis polyzona</i> 4 Mono and polyaromatics reduction after 20 days by <i>Corioloipsis polyzona</i>	Jaouani <i>et al.</i> , 2003
21	Wastewater	Removal of total phenols	Measurement of germinability of <i>triticum durum</i>	Use of lacasse	In a germination chamber for 8 days according to the rules for seed testing published by the Association of Official Seed Analysts (1981)	Increase in germinability 57–94%	Casa <i>et al.</i> , 2003	
22	Wastewater	Biodegradation by two aerobic bacterial strains	Aromatic acids	Growth of <i>Ralstonia</i> spp. and <i>Pseudomonas putida</i> in OMW	HPLC for aromatic acids	Degradation of monocyclic aromatic compounds	Di Gioia <i>et al.</i> , 2001	
23	Wastewater	Transformation of four phenols (catechol, methylcatechol, m-tyrosol and hydroxytyrosol)	Phenols	Transformation of four phenols using an oxyreductase	HPLC	Transformation of phenols 32–55%	Gianfreda <i>et al.</i> , 2003	
24	Wastewater	Aerobic biological treatment followed by electrochemical oxidation	COD, EC, pH, BOD, TS, TSS, VS, VSS, NH_4^+ , P, K, Cl^- , phenols	First stage: <i>Aspergillus niger</i> and second stage: electrolysis in presence of H_2O_2	1 <i>Standard methods</i> for COD, EC, pH, BOD, TS, TSS, VS, VSS, NH_4^+ , P, K, Cl^- 2 GC for phenols	1 <i>First stage</i> : reduction in COD (66–86%) and phenols (65%) 2 <i>Second stage</i> : reduction in COD (96%) and phenols (96%)	Kyriacou <i>et al.</i> , 2005	

(Continued)

Table 8.4 (Continued)

No	Kind of waste	Treatment	Parameters	Methodology	Quality control methods	Results	References
25	Wastewater	Decoloration, dephenolization, and detoxification of wastewaters	Activity of the extracellular and mycelial-bound enzymes	Incubation of <i>Phanerochaete flavidio-alba</i> for 48 h at 30°C	1 Extracellular enzymes: SDS-PAGE and isoelectric focusing 2 Mycelial-bound enzymes: broken-mycelium suspensions in 50 mM sodium malonate buffer (pH 4.5) according to Périé and Gold (1991)	1 Decoloration 60% (after 48 h of incubation) 2 Phenolics degradation 3 OMW detoxification	Ruiz <i>et al.</i> , 2002
26	Wastewater	Phenol oxidation	Phenols content and toxicity	Ligninolytic fungus <i>Pleurotus ostreatus</i>	1 Colorimetric assay for phenols 2 Toxicity assays by using <i>Bacillus cereus</i> (strain 6E/2)	1 <i>Biological treatment</i> : reduction of phenols (up to 90% after 100 h) 2 <i>Purified phenol oxidase</i> : phenol reduction (90%), no detoxification of OMW	Martirani <i>et al.</i> , 1996
27	Wastewater	Decoloration and detoxification of wastewaters	Activity of the extracellular enzymes	Use of <i>Phanerochaete flavidio-alba</i>	Extracellular enzymes: according to Perez <i>et al.</i> (1996)	Removal of simple and polymeric phenols	de la Rubia <i>et al.</i> , 2002
28	Wastewater	Enzymatic treatment	Ligninolytic enzyme lacasse (fungus product)	Inoculation of <i>Pycnoporous coccineus</i> lacasse to OMW	Brandford method using Bio-Rad protein assay and bovine serum albumin as standard	Decrease in phenolic content, COD, color	Jaouani <i>et al.</i> , 2005
29	Wastewater	Immobilized <i>Lentinula edodes</i> laccase	Phenols, <i>ortho</i> -diphenols, color	Incubation of filter-sterilized OMW at 30°C with immobilized laccase Further treatment of OMW with immobilized laccase at the same temperature in a column operated as a fluidized bed reactor	1 Folin-Ciocalteau method for phenols 2 Molibdate/sodium nitrate method for <i>ortho</i> -diphenols 3 Spectrophotometer (465 nm) for color	Decrease in total phenols, <i>ortho</i> -diphenols and color	D' Annibale <i>et al.</i> , 1999

B Thermal processes

30	Olive cake	Drying	Calorific value	<ol style="list-style-type: none"> 1 Cabinet dryer using heated ambient air: 80–110°C, 1–2 m/s air velocity 2 Then samples left cool 	Standard bomb calorimeter (IKA-Calorimeter C4000)	Rate of moisture loss higher at higher temperatures, total drying time reduced at increased air temperature, increased sample thickness caused decrease at the absorbed moisture, activation energy 26–71 kJ/mol	Doymaz <i>et al.</i> , 2004
31	Alpeorujo (solid waste)	Drying	Volatile emissions	Drying tunnel	Difference between initial and final volatile contents	<ol style="list-style-type: none"> 1 Increase in drying rate with increase in sample diameter and temperature 2 Small diameter samples need less time to achieve a specific moisture content 	Arjona <i>et al.</i> , 1999
32	Olive seeds (solid waste)	Carbonization	Absorbance	<ol style="list-style-type: none"> 1 Closed crucible at 800°C 2 Then the sample left cool and washed 	Spectrophotometer at 690 nm wavelength	<ol style="list-style-type: none"> 1 Production of activated carbon better than commercial type 2 Fresh activated carbon better than regenerated and commercial type 	Walid, 2001
33	Olive seed waste residue	Carbonization (using N) and activation (with CO ₂)	Adsorptive capacity, chars	Fluidized-bed reactor	<ol style="list-style-type: none"> 1 Color removal towards methylene blue dye for adsorptive capacity 2 Iodine number tests for char characterization 	<ol style="list-style-type: none"> 1 Production of activated carbon 2 Higher adsorption capacity for longer activation time, higher temperatures 3 Improvement of activation time by decreasing sample size 	Al-Khalid <i>et al.</i> , 1998
34	Olive husk and vegetation	Pyrolysis	COD, gases, ash content, polyphenols, heating value, elemental	Samples dried in oven 105°C, main pyrolysis followed by a slow	1 Colorimetric methods (Hach DR/2000) for COD	Final products: <ol style="list-style-type: none"> 1 Vegetable water: CO₂, H₂, CO, 	Vitolo <i>et al.</i> , 1999

(Continued)

Table 8.4 (Continued)

No	Kind of waste	Treatment	Parameters	Methodology	Quality control methods	Results	References
	water residues		analysis for concentrated VW residues and olive husk and chars, suspended matter in VW, density of VW	and continuous degradation until 75% (vegetation water residues) and 80% (olive husk) pyrolyzed 800°C	2 GC for gases 3 Perkin-Elmer Inductively Coupled Plasma (ICP)-Atomic Emission Spectrophotometer (AES), model 400 for ash content 4 Qualitative test using iron for polyphenols 5 Barthelot-Mahler test for heating value 6 IR CHN 600 detector for S,H,N and IRSC-432 DR detector for S,P,Cl for concentrated VW residues and olive husk and chars 7 IRSA-CNR method no. 2050 for suspended matter in VW 8 Paar KG densimeter, model DMA 58 for density of VW	CH ₄ , C ₂ H ₄ 2 Olive husk: CO ₂ , H ₂ , CO, CH ₄ 3 Char, tar 4 Mixture of vegetable water and olive husk can be used as a fuel	
35	Waste sludge (water, oil, olive skin, olive husk)	Co-combustion	CO, O ₂ , CO ₂	The waste was pre-dried and co-fired (830–940°C) with coal in a fluidized bed (sand)	1 Xentra 49040B1 continuous emissions analyzer for CO, O ₂ 2 Non-dispersive infrared absorption spectrometry analyzer for CO ₂	1 10% waste and 90% coal: lower CO I emissions than 100% coal 2 20% waste and 80% coal: higher CO I emissions above all	Cliffe and Patumsawad, 2001
36	Olive stones	Carbonization and activation	Weight loss	1 Carbonization: horizontal tube furnace heated up to 850°C at 20°C under constant flowing N ₂ 2 Activation: same temperature	Gravimetrically	1 Final products good adsorptive capacity in aqueous medium 2 Weight loss due to carbonization 80–85.5%	El-Sheikh <i>et al.</i> , 2003

37	Olive refuse	Briquetting	Burning profile	Briquetted in a steel die under pressure (150 and 250 MPa) at ambient temperature	Thermogravimetric analysis by using Shimadzu TG 41 thermal analyzer	Production of fuel briquettes with low mechanical strength	Yaman <i>et al.</i> , 2000
38	Olive stones (whole stones and seed husks)	Pretreatment with steam followed by explosion	Ash, protein, uronic acids, total polyphenols, total sugars	Reactor 200–236°C, 2–4 min, previous impregnation with 0.1% H ₂ SO ₄ (w/w)	<ol style="list-style-type: none"> 1 Association of Official Analytical Chemists (AOAC) method for ash 2 Kjeldhal method for protein 3 Phenylpheno for uronic acid 4 Folin-Denis reagent and caffeic acid as standard for total polyphenols 5 GC for total sugars 	<ol style="list-style-type: none"> 1 Conversion of hemicelluloses into soluble carbohydrates 2 Production of fermentable carbohydrates 	Fernandez-Bolanos <i>et al.</i> , 2001
<i>C Evaporation</i>							
39	Vegetation water	Concentration	COD, vapors	Evaporation (under vacuum or atmospheric pressure)	Colorimetric method (analysis by a Hach DR/2000 spectrophotometer) for O ₂ and vapors	<ol style="list-style-type: none"> 1 Reduction of COD (98%) in condensed vapors 2 Reduction organic load in the residues (98%) 3 Absence of polyphenols in condensed vapors 	Vitolo <i>et al.</i> , 1999
<i>D Membrane processes</i>							
40	Wastewater	Fractionation by ultrafiltration and reverse osmosis	COD, BOD and phenols	Toxicity testing for on aquatic microorganisms	<ol style="list-style-type: none"> 1 Open reflux method for COD 2 A 5-day BOD test for BOD 3 Spectrophotometry for phenols 	Fraction from reverse osmosis toxic	Fiorentino <i>et al.</i> , 2003
41	Wastewater	Ultrafiltration	Fats, ashes, total organic and inorganic compounds, COD, polyphenols	Pretreatment of OMW with centrifugation followed by ultrafiltration of the centrifuge supernatant (30°C)	<ol style="list-style-type: none"> 1 Soxhelt extraction for fats, ashes, total organic and inorganic compounds 2 1-COD_{permeate}/COD_{wastewater} for COD 3 Folin reagent for polyphenols 	<ol style="list-style-type: none"> 1 COD reduction 90% 2 Ashes and suspended solids reduction 80% 	Turano <i>et al.</i> , 2002

(Continued)

Table 8.4 (Continued)

No	Kind of waste	Treatment	Parameters	Methodology	Quality control methods	Results	References
<i>E Electrolysis</i>							
42	Wastewater	Electrolysis	COD, TOC, VSS and total phenolic compounds	Wastewater and NaCl 4% (electrolyte) passing through the electrolytic cell (anode: Ti/Pt, cathode: stainless steel)	1 Total phenolic compounds with the Folin-Ciocalteu method 2 COD, TOC, VSS with methods for examination of water and wastewater	Reduction in COD 93%, TOC 80.4%, VSS 98.7% and total phenolic compounds 99.4% after 10 h of treatment at 0.96 A/cm ²	Israilides <i>et al.</i> , 1997
<i>F Ozonation</i>							
43	Wastewater	Ozonation	COD, aromatics, phenolics	Mixed batch reactor fed by wastewater and ozon-oxygen gas stream (1atm, 20°C)	1 Folin-Ciocalteu method for phenolics 2 Absorbance at 254 nm for aromatics	Reduction in COD, removal of aromatics and total phenolic compounds	Benitez <i>et al.</i> , 2000
44	Wastewater	Ozonation	Phenolic acids concentration	Treatment of phenolics in a semicontinuous reactor with ozone produced in an ozone generator	HPLC (with UV detector)	The orders of acid degradation being caffeic > <i>p</i> -coumaric = syringic > vanillic > 3,4,5-trimethoxybenzoic = veratic > <i>p</i> -hydroxybenzoic > protocatechuic	Benitez <i>et al.</i> , 1997
45	Solution of cinnamic acid, <i>p</i> -coumaric acid, caffeic acid and ferulic acid	Ozonization	COD	Use of ozone	Device for the measurement of oxygen (respiration)	Lower COD 50%	Amat <i>et al.</i> , 2003
<i>G Digestion</i>							
46	Wastewater	Anaerobic biodegradation of wastewaters or/and olive pits	COD	Anaerobic biodegradation	(Biochemical Methane Potential -BMP) -Hach spectrophotometer	1 57.1 ± 1.5 litres methane/l of wastewaters 2 Lower COD 85.4–93.4%	Ergüder <i>et al.</i> , 2000

47	Wastewater	Anaerobic digestion	COD, TON, phenols, pH, TOC, organic carbon, biogas production	First stage: up-flow digester and second stage: fixed-bed digester	<ol style="list-style-type: none"> 1 <i>Standard methods</i> for COD, TON, phenols, pH 2 Photochemical oxidation of the organic compounds for TOC 3 Photochemical analyzer for organic carbon 4 ORSAT meter for biogas production 	<ol style="list-style-type: none"> 1 <i>First stage:</i> biogas production (2.1 l/l digester.day) and reduction of COD (75–85%), TOC (68–78%), phenols (73%), volatile acids (75%) 2 <i>Second stage:</i> biogas production (0.5 l/l digester.day) and reduction of COD (15–20%), TOC (15–20%), phenols (35%), volatile acids (45%) 	Dalis <i>et al.</i> , 1996
48	Wastewater	Anaerobic digestion	COD, BOD ₅ , pH, TMS, VSS, NH ₄ ⁺ , P, alkalinity, methane, volatile acids	Anaerobic reactor combining a filter and an upflow sludge blanket reactor (mesophilic conditions)	<ol style="list-style-type: none"> 1 <i>Standard methods</i> for COD, BOD₅, pH, TMS, VSS, NH₄⁺, P, alkalinity 2 GC for methane and volatile acids 	<ol style="list-style-type: none"> 1 COD reduction 89% 2 Biogas production (methane content 69–75%) 	Borja <i>et al.</i> , 1995
49	Wastewater	Aerobic pretreatment followed by anaerobic digestion	–	<ol style="list-style-type: none"> 1 2 	<ol style="list-style-type: none"> Pretreatment of OMW with <i>Phanerochaete chrysosporium</i> Biomethanation of pretreated OMW in anaerobic filter 	<ol style="list-style-type: none"> 1 COD reduction (50%) 2 Biomethanation inhibition 	Gharsallah <i>et al.</i> , 1999
<i>H Coagulation/flocculation/precipitation</i>							
50	Wastewater	Separation of wastewater from its aqueous suspension	Turbidity, COD	Coagulation (chitosan, starch, ferric chloride, alum) followed by an induced air flotation system	<ol style="list-style-type: none"> 1 Partech Turbidometer for turbidity 2 Gallen-kamp COD measuring device for COD 	<ol style="list-style-type: none"> 1 <i>Alum and chitosan:</i> reduction of turbidity 90% 2 <i>Starch and ferric chloride:</i> not effective coagulants 3 COD reduction 95% (at optimum conditions) 	Meyssami and Kasaeian, 2005
51	Olive mill effluents	Direct flocculation with	TSS, COD, BOD ₅	Flocculation with 4 cationic and 2 anionic	<ol style="list-style-type: none"> 1 Filtering well-mixed sample through a Pall glass-fiber filter, drying 	<ol style="list-style-type: none"> 1 Complete removal of TSS, COD and BOD by 3 cationic 	Sarika <i>et al.</i> , 2005

(Continued)

Table 8.4 (Continued)

No	Kind of waste	Treatment	Parameters	Methodology	Quality control methods	Results	References
		poly-electrolytes		poly-electrolytes; use of ferric chloride and lime as reference coagulants	the residue retained on the filter 103°C/60 min, increase of weight of the filter corresponds to TSS 2 Spectrophotometer DR/2010 for COD 3 Measuring oxygen uptake in a sample for 5 days, 20°C, in the dark using the BODTrak apparatus for BOD	and 1 anionic poly-electrolyte at minimum dosage 2 Remaining poly-electrolytes not effective 3 Ferric chloride and lime: capable of removing TSS, but not reducing COD	
52	Wastewater	Electro coagulation	COD, SS, color, pH	Reactor with aluminum and iron electrodes (21–22°C, 12V, pH 4–9, current density 10–40 mA/cm ² , 2–30 min)	1 Spectrophotometer for COD and color 2 Standard methods for SS 3 pH meter	1 <i>Fe electrode</i> : 42% COD reduction (10–15 min), 96% color reduction (10–30 min), 48–68% SS removal (2–10min) 2 <i>Al electrode</i> : 52% COD reduction (30 min), 96% color reduction (10–30 min), 48–68% SS removal (2–10min)	Inan <i>et al.</i> , 2004
53	Wastewater	Electro coagulation	COD, total polyphenols, total solid content, dark color, pH, conductivity	Using sacrificial aluminum electrodes (25 min, 75 mA/s, pH 4–6)	1 Association of Official Analytical Chemists (AOAC) methods for COD 2 Spectrometric procedure using FCR selective reagent for polyphenols	1 <i>Fresh OMW</i> : reduction of COD 75.8%, polyphenols 91.4%, removal of dark color 95% 2 <i>Stored OMW</i> : reduction of COD 71%, polyphenols	Adhoum and Monser, 2004

					3 Drying 100 ml aliquot of OMW at 105°C until constant weight for total solid content	93%, removal of dark color 95%	
					4 UV-Vis spectrophotometer DR-5000 for dark color		
					5 pH meter (Radiometer PHM 210) and conductivity meter (Radiometer CDM 230) for pH and conductivity		
<i>I Distillation</i>							
54	Wastewater	Solar distillation	TS, VS, COD, TKN	Solar still containing OMW left in outside conditions for 9 days (average ambient temperature 26.8°C and solar radiation 34 kWh)	Standard methods for TS, VS, COD, TKN	1 Distillate: reduction of COD 80% and TKN 90% (in the basin) 2 Residues: no presence of solids	Potoglou <i>et al.</i> , 2003
Adapted from Arvanitoyannis <i>et al.</i> , 2007							

Table 8.5 Advantages and disadvantages of olive oil waste treatment methodologies

No	Treatment technique	Advantages	Disadvantages	References
1	Bioremediation	<ol style="list-style-type: none"> 1 Natural and safe process 2 Cost effective 3 Final solution 4 Non-disruptive and non-invasive 5 Performed <i>in-situ</i> 	<ol style="list-style-type: none"> 1 Ineffective for non-degradable systems 2 Biodegradation products occasionally more toxic than the parent compounds 3 Lengthier than other treatment methods 4 Constant monitoring to ensure effectiveness 5 Not applicable to complex mixtures of contaminants 	<p>http://www.obio.com/bioremediation.htm, http://www.nzbcscd.org.nz/story.asp?id=21, http://www.library.thinkquest.org/03oct/01840/New%20Page_5.htm, http://www.woodrow.org/teachers/help/temp_presentations/kim/bioremediation.htm</p>
2	Incineration	<ol style="list-style-type: none"> 1 Requirements for minimum land 2 Can be operated in any weather 3 Production of stable odor-free residue 4 Reduction of refuse volume by half 	<ol style="list-style-type: none"> 1 Expensive 2 High energy requirements 3 Requirements for skilled personnel and continuous maintenance 4 Smell, waste, vermin 5 Air pollution 	<p>http://www.gdrc.org/uem/waste/disposal.html, http://www.tnswep.ra.utk.edu/activity_H_e.htm</p>
3	Pyrolysis	<ol style="list-style-type: none"> 1 Production of a gas/liquid for energy production 2 Reduced demand for landfill 3 Relatively rapid 4 Semi-quantitative 5 Samples analysis irrespectively of solubility 	<ol style="list-style-type: none"> 1 Not commercially proven for municipal solid/household waste 2 Difficult to transfer heat to feedstock 3 Unlikely to be suitable for direct degradation of untreated municipal solid waste 4 Difficult to control product quality 5 May inhibit waste minimization and recycling 	<p>http://www.swampni.org.uk/downloads/5193.00%20SWaMP%20WMP%20-%20Section%205.pdf, http://www.cranfield.ac.uk/sims/waste/cpdcourses.htm</p>
4	Gasification	<ol style="list-style-type: none"> 1 Gas production for energy production 2 Reduced demand for landfill 3 Use of low emission technology 4 Operation at a lower temperature and wider variety of feed stocks 5 Production of nitrogen free gas 6 Less landfill waste 	<ol style="list-style-type: none"> 1 Not commercially proven for municipal solid/household waste 2 Low heating value gas 3 May inhibit waste minimization and recycling 4 Limited number of technology suppliers 5 Small amounts of released tar in the gas coats parts of the pipe or the equipment 	<p>http://www.swampni.org.uk/downloads/5193.00%20SWaMP%20WMP%20-%20Section%205.pdf, http://www.kentlaw.edu/classes/fbosselm/Spring2004/PowerPoints/Biomass%20-%20Schanz%20&%20Garvey.ppt</p>
5	Evaporation	<ol style="list-style-type: none"> 1 Low capital cost 2 Small square footage requirements for equipment and little storage space needed 3 Minimal labor requirements 4 Simple to operate and maintain 5 Able to handle a mixed and varied waste stream 6 Residue is as little as 1% of original volume 7 Eliminate meeting requirements for sewer or groundwater discharge 	<ol style="list-style-type: none"> 1 Significant amount of energy 2 An air permit may be required (atmospheric evaporator only) 3 Foam production may be a problem 4 Lower efficiency with more concentrated solution 5 Fire hazard (liquids with a low flash point) 6 Vapor odors can be obnoxious 7 Vapors and/or solutions may be corrosive 	<p>http://www.lakeviewengineered.com/whyevaporate.html, http://www.aware-services.com/orc/evaporat.htm</p>

		<ul style="list-style-type: none"> 8 Cost advantage over other fluid management systems 9 Water recovery for reintroduction into closed loop application 10 Limits long-term liability for waste generator 		
6	Membrane processes	<ul style="list-style-type: none"> 1 Separation of a wide variety of emulsion, surfactant and chelating chemistries and various mixtures 2 No specific chemical knowledge is required 3 No complex instrumentation is required 4 The basic concept is simple to understand 5 Lower energy costs 6 Reliability 7 Reduced capital costs 8 Effective pollution control 	<ul style="list-style-type: none"> 1 High cost 2 Lack of selectivity 3 Low fluxes 4 Sensitive to chemical attack (acids, oxidants or organic solvents) 5 Lack of mechanical resistance (abrasion, vibrations, high temperatures or pressures) 	<p>http://www.etseq.urv.es/DEQ/Doctorat/index/running/2002_2004/courses_w/memb_sep/Memb03.pdf http://www.aware-services.com/orc/membrane.htm, http://www.rimnetics.com/osmotek3.htm</p>
7	Electrolysis	<ul style="list-style-type: none"> 1 Simple equipment that can treat small-volume wastes 2 Possibility of either oxidative or reductive treatment 3 Cost effective 	<ul style="list-style-type: none"> 1 Higher capital and operating costs 2 pH adjustment is required before treatment 3 Increased maintenance and training requirements 4 Not selective method 5 Constant monitoring 6 Poor at treating variable content, high volume effluents 7 High electric potentials are safety hazards 	<p>http://www.gewater.com/library/tp/844_Ozonation_.jsp http://www.crd.bc.ca/es/environmental_programs/source_control/documents/bestpractices_photo.pdf, http://www.emis.vito.be/EMIS/Media/non-ferro_bijlage6.pdf</p>
8	Ozonation	<ul style="list-style-type: none"> 1 Odor elimination 2 Reduction of oxygen demanding matter, turbidity and surfactants 3 Colors, phenolics and cyanides removal 4 Increased dissolved oxygen 5 No significant toxic side 6 Increase in suspended solids reduction 7 Short contact time (10-30 min) between ozone and wastewater is required 	<ul style="list-style-type: none"> 1 High capital cost 2 High electric consumption 3 Low dosages may not effectively inactivate some viruses, spores and cysts 4 More complicated than other disinfection technologies 5 Ozone is very reactive and corrosive, thus requiring corrosion-resistant material 6 Non-economical method for poor quality (poorly treated) wastewater 7 Extremely irritating and possibly toxic off-gases 	<p>http://www.iconpr.com/news/news_see.cfm?inv_id=190-1, http://www.iconpr.com/news/news_see.cfm?inv_id=190-1, http://www.nesc.wvu.edu/nsfc/pdf/eti/Ozone_Dis_gen.pdf</p>
9	Aerobic digestion	<ul style="list-style-type: none"> 1 Low capital cost 2 Simple and safe operational control 	<ul style="list-style-type: none"> 1 Production of huge amounts of biosolids (sludge) 2 High power costs associated with aeration 	<p>http://www.biotank.co.uk/aerobic.htm, http://www.engr.uga.edu/service/outreach/HandlingProcesses.pdf http://www.biotank.co.uk/aerobic.htm, http://www.engr.uga.edu/service/outreach/publications/biosolids/Ch03-Solids</p>

(Continued)

Table 8.5 Advantages and disadvantages of olive oil waste treatment methodologies

No	Treatment technique	Advantages	Disadvantages	References
		<ul style="list-style-type: none"> 3 Low odor potential 4 Non-explosive gas production 5 Relatively clean recycle stream 6 Energy release 7 Fast and efficient pollutant removal 		
10	Anaerobic digestion	<ul style="list-style-type: none"> 1 Ability to generate electricity and heat (through the combustion of the biogas) 2 Odor control 3 Reduction of pathogens 4 Ability to use digested (separated) solids as bedding 5 Ability to spread digested (separated) liquid effluent at different times and different places than was previously 6 Socially acceptable 7 No dioxins or other toxic by-products 	<ul style="list-style-type: none"> 1 High capital and operating costs 2 Slower waste disposal than incinerators 3 Ineffective treatment of plastics and other synthetic wastes 4 Difficult to manage with heterogeneous wastes 5 Good sorting of incoming refuse, more labor intensive 	<p>http://www.bee.cornell.edu/extension/manure/anaerobic_digestion.htm, http://www.wte.cbll.net/methods/anaerobic.html</p>
11	Coagulation/flocculation/precipitation	<ul style="list-style-type: none"> 1 Well-established technology with readily available equipment 2 Some treatment chemicals (i.e. lime) are very inexpensive 3 Completely enclosed systems are often conveniently self-operating with low maintenance 4 Removal of very fine particles 5 Increase in agronomic value of the sludge 6 Effective in removing protozoa, bacteria and viruses 	<ul style="list-style-type: none"> 1 Calculation of proper chemical dosages is impossible (due to the competing reactions) 2 Jar tests are necessary for confirmation of optimal treatment conditions 3 Overdosing greatly decreases the effectiveness 4 Required working with corrosive chemicals (precipitation) increases operator safety concerns 5 Chemicals addition (i.e. lime) increases waste sludge volume up to 50% 6 Transportation of large amounts of chemicals to the treatment location 7 Polymers can be expensive 	<p>http://www.epa.gov/owm/mtb/chemical_precipitation.pdf, http://www.who.int/entity/water_sanitation_health/dwq/en/S12.pdf, http://www.cals.ncsu.edu/waste_mgt/natlcenter/modules/powerpoint5.pdf</p>
13	Distillation	<ul style="list-style-type: none"> 1 Most effective broad spectrum water treatment technology 2 Best method for removal of inorganics, bacteria and viruses 3 Easy maintenance and installation 4 Long lasting equipment 	<ul style="list-style-type: none"> 1 High cost 2 Requirements for large amounts of energy and water 3 Organic chemicals may be carried over with steam 	<p>http://www.aquawaveh2o.com/web/technology/distillation/distillation.htm, http://www.pacificro.com/Solutio2.htm</p>

Adapted from Arvanitoyannis *et al.*, 2007

for use in agriculture and in industry (Capasso, 1997; Capasso *et al.*, 1999) are the most commonly adopted approaches for their disposal (Figure 8.24).

Root-knot nematodes, *Meloidogyne* spp., are economically important plant pathogens that can be managed by cultivation practices, chemical nematicides and resistant cultivars. Nico *et al.* (2004) conducted an experiment to determine whether amending a potting mixture with a mixture of dry-olive marc and dry-rice husk (1:1 v/v) compost at rates of 0%, 25%, 50%, 75% and 100% (v/v), would suppress root galling and final populations of *Meloidogyne incognita* race 1 and *Meloidogyne javanica* in tomato. A limited reduction of root galling and nematode populations was recorded irrespective of *Meloidogyne* species or rate of amendment, due to the low extent of nematicidal activity in the compost. Therefore, the compost is not suitable for the management of root-knot nematodes on potting mixtures. However, the root galling and final populations of *Meloidogyne incognita* race 1 and *Meloidogyne javanica* in tomato, were substantially reduced when the potting mixture was amended with composted dry cork and dry-grape marc, whereas the final nematode population in olive plants decreased only when dry cork was used as an amendment.

The growth of ornamental plants in a composted mixture of a solid fraction of OMW (65%) and olive leaves (35%) was investigated by Garcia-Gomez and his coworkers (2002a). The mixture was composted in a pilot plant with the Rutgers static pile system, with forced aeration and controlled temperature (Finstein *et al.*, 1983) for 190 days, and mixed up to 50% with sphagnum peat or with a commercial substrate (CS) prepared from composted grape marc. Two plant species, calendula (var. *Nana Bon-Bon*) and calceolaria (dwarf var. *C. dainty*), were tested for their ability to grow on the above mixtures. It was found that the mixtures containing up to 50% peat or CS can be effectively used as substrates for the growing of moderately tolerant to salinity plant species, while mixtures comprising 25% peat or CS can be used as substrates for the growing of calendula and calceolaria (salt-sensitive species).

The characteristics of the crop (quality and quantity) and the changes in the soil (chemical and microbiological properties) after controlled spreading of OMW on soil cultivated with olive trees and grapevine was studied by Marsilio *et al.* (2006). The spreading of 10 and 30 l/m² OMW on soil cultivated with olive trees (cv. *Gentile di Chieti*) reduced or avoided the use of chemical fertilizers. The olive fruit production was equal or higher than that obtained in the control and the olive oils had the same qualitative characteristics. For grapevine (cv. *Trebbiano d'Abruzzo*) cultivation, spreading of 10 l/m² OMW resulted in the same grape production as the control, while the use of fertilizers was reduced up to 50%. A quantity of 50 l/m² OMW resulted in a 30% increase in production, avoiding the use of chemical fertilizers. The qualitative characteristics of the grape juice and the chemical and microbiological properties of the soil were not influenced by the quantity of OMW spread on the soil.

The composting of olive oil husks was investigated by using two different aeration techniques; forced aeration by air injection and mechanical stirring (Baeta-Hall *et al.*, 2005). The olive husks were blended with 2% (w/w) grape stalks and two trapezoidal piles were constructed (pile I and pile II). In pile I, the mixture was stirred with a plow, whereas in pile II, the aeration was induced by means of a centrifugal ventilator. After six months of composting both piles were of similar chemical composition, with

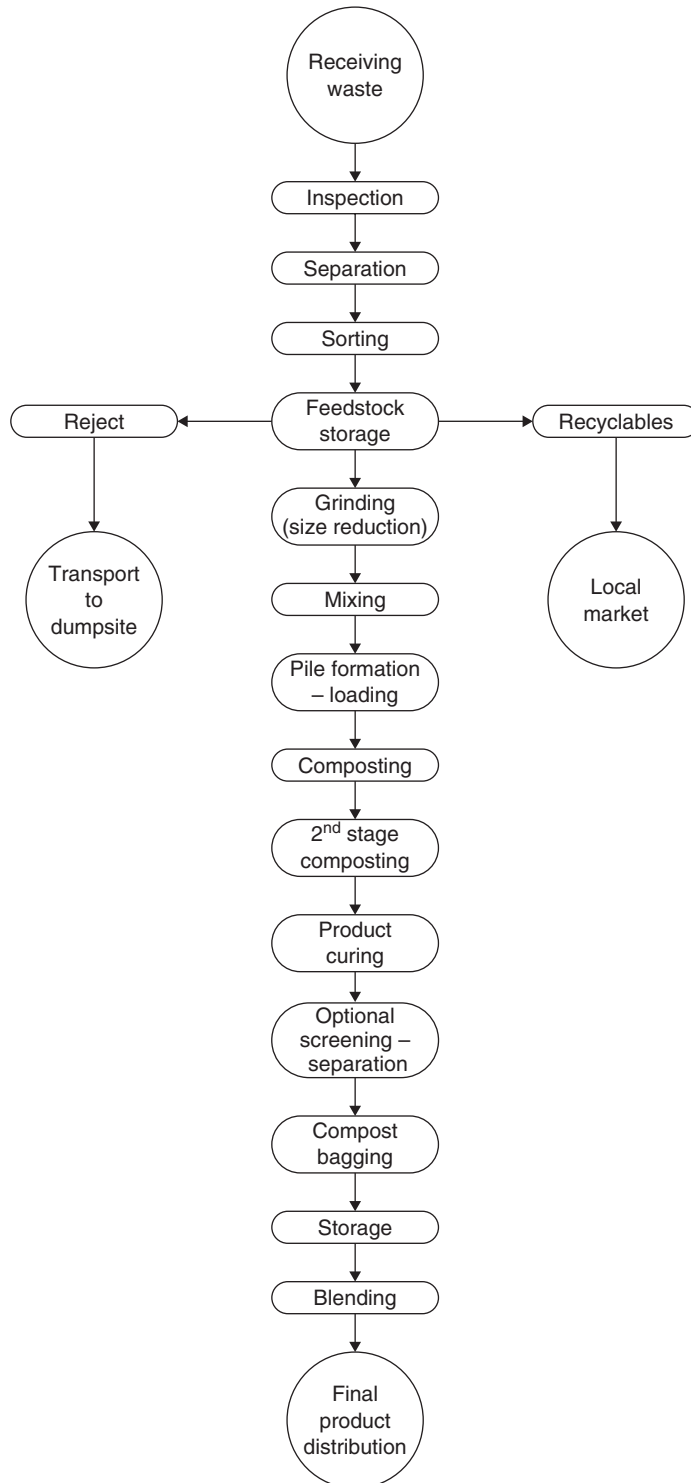

Figure 8.24 Diagram of common operations in a typical composting system (adapted from http://www.uwm.edu/Dept/CBU/Presentations/UANL_Lecture_One.pdf; <http://www.epa.gov/owm/mtb/invessel.pdf>; http://www.wasteconcern.org/Publication/rcr_composting_bangladesh_zurbrugg_2004.pdf, Arvanitoyannis and Kassaveti, 2006a)

approximately the same level of organic matter degradation (55%) and an active microbial community. Moreover, pile I exhibited a more rapidly developing process and higher humification efficiency than pile II, due to the more effective mechanical stirring and the progressive temperature increase.

The addition of elemental sulfur during windrow composting of two mixtures of OMW and sheep litter (SL) was examined by Roig and his coworkers (2004). The composition of the two mixtures was as follows: compost A; 50% OMW + 50% SL fresh weight (33:66 dry weight) and compost B; 74% OMW + 26% SL fresh weight (60:40 dry weight). Bench-scale experiments were conducted in compost A at various moisture contents, sulfur concentration and incubation temperature on the sulfur oxidation rate. The results showed a decrease in pH at optimal conditions (40% moisture content and 0.5% dry weight concentration of sulfur) and absence of phytotoxicity of the compost. The optimum experimental conditions found by bench-scale experiments were applied at full scale in compost B. A similar pH reduction was recorded after two weeks bearing no negative effect on the final compost quality.

A mixture of sewage sludge (33%), cotton gin waste (67%) and 0.91 OMW/kg (9:88:3 dry weight basis) were composted in a pilot plant in trapezoidal piles. The OM degradation resulted in pH and electric conductivity (EC) increase, low nitrate concentrations, low contents of toxic heavy metals and no phytotoxic effects, when applied on Swiss chard plants (*Beta vulgaris* L. var. *cicla*) and positive effects on soil fertility. However, when the compost was applied at high doses (60 tonnes/ha) the soil salinity increased at alarming levels, due to Cl^- and Na^+ ions, thereby highlighting the major concern regarding the application of OMW compost at high rates in soil (Paredes *et al.*, 2004).

Ehaliotis *et al.* (2005) used mature and immature compost consisting of olive tree leaves (40%) and olive pomace (60%) as soil amendments, in order to examine their ability to heat the root zone and provide nutrients for organically grown cucumber plants (*Cucumis sativus*). In the mature compost, by-products of olive mills were composted in windrows, according to the composting procedure described by Manios (2004), whereas in the immature compost the raw materials were not composted. Two experiments were performed; in the first case the mature compost was blended with greenhouse soil and the mixture was applied on top of the immature compost heaps in the greenhouse, while the cucumber seeds were grown on the soil–mature compost layer; and in the second case, a cucumber hybrid was planted in a blend of mature compost and low fertility soil in the greenhouse. In the first experiment, it was found that the mature compost heated the rhizosphere effectively over the whole production period and no toxic effects were observed on the rooting systems of cucumber plants. In the second experiment, the blend of mature compost and soil greatly affected the plant growth and production. Furthermore, the soil organic matter content increased and N, P and K availability was considerably enhanced, but only high application rates of compost could meet the plant growth nutrient requirements.

Field trials were carried out to evaluate the potential effects of using husks as a soil amendment on soil fertility and olive growth and yield. Large quantities (100 ton/ha) of olive husk were spread on an olive grove, while plots without husk addition were used as the control. The soil of treated plots showed a slight reduction in pH, an increase in

organic matter, nitrogen, exchangeable potassium, available phosphorus and magnesium, better microbial activity and absence of phytotoxicity in olives. Trees showed higher shoot growth and yield as well as higher fruit growth and oil accumulation. Furthermore, there were no effects of husk addition on oil quality. The results obtained were promising for the use of olive husks on olive groves (Nasini *et al.*, 2006).

Benitez *et al.* (2005) vermicomposted mixtures of dry olive cake alone or mixed with municipal biosolids at a ratio of 8:1 (dw:dw) for 9 months in order to examine the behavior of three specific humic substance-enzyme complexes (humus- β -glucosidase complex, humus-urease complex and humus-phosphatase complex). During the process, β -glucosidase synthesis and release was observed, whereas no significant change in urease and phosphatase activity was recorded. The vermicomposted olive cake, alone or in blends with biosolids, could be effectively used as amendment due to their ability to reactivate the C, P and N-cycles in degraded soils for regeneration purposes.

Alburquerque and his coworkers (2006) co-composted 'alperujo' (AL), a solid by-product of the olive oil industry, with cotton waste, used as bulking agent and the compost obtained was evaluated as an organic amendment for the production of pepper (*Capsicum annuum* cv 'Orlando') on a calcareous soil in a greenhouse. This fertilizer was compared with cattle manure and sewage sludge compost. It was shown that the produced compost can be effectively used as an amendment because it was toxicity free, rich in organic matter and lignin and highly resistant to soil biodegradation in the harsh thermal conditions of the greenhouse. Furthermore, it had a considerable potassium and organic nitrogen content but was deficient in phosphorus and micronutrients, whereas the cattle manure and the sewage sludge compost caused a considerable reduction in organic matter.

The amount of peat that could be replaced by olive cake and olive leaves compost in the commonly used growing medium of *Euphorbia pulcherrima* (poinsettia consisting of peat with perlite), was determined by Papafotiou and coworkers (2004). The blend of olive cake and olive leaves was drenched with OMW and composted for 3 months according to the method described by Papadimitriou *et al.* (1997). A 25, 50 and 75% replacement of peat in the medium by the obtained compost was compared with a medium of 1 peat:1 perlite (by volume), used as control. The results revealed that the produced compost could replace up to 25% of the peat in a medium with perlite, because the quality of the produced plants was the same as when the control was used as growing medium in the production of poinsettia, even if a decrease in the plant height and the node number was observed. When peat was replaced up to 50%, the compost caused decrease both in total porosity and water availability, decrease in plant height and bract number, restriction of vegetative growth for only the first month and delayed pigmentation of bracts and flowering. A 75% replacement of peat resulted in a further decrease in total porosity and the water availability, reduction in root dry weight, restriction in vegetative growth over the whole cultural period and delayed pigmentation of the bracts and flowering.

Extracted olive press cake (EOPC), olive tree leaves (OTL) and olive tree branches (OTB) accumulate as waste at olive oil mills and are one of the most important organic waste residues on the island of Crete (Greece). The above agricultural residues were composted separately, either in windrows in the open air or under cover (shelter) and the piles were manually turned. The EOPC compost had high lignin content (20%),

dark appearance (black), sufficient nutrient amount, satisfactory physicochemical characteristics, persistence in soils and substrates and was essential in humus formation. The OTL compost had a slightly alkaline pH (7.5), large amount of humic substances, $\text{NO}_3\text{-N}$ accumulation and high EC (3.7 mS/cm) that is responsible for the phytotoxic effects when applied in large amounts (more than 30% by volume), while the OTB compost had low organic matter and high EC (9.8 mS/cm). Both OTL and OTB composts can be effectively used as bulking agents when mixed with high moisture content materials (Manios, 2004).

OMW was applied for 3 years at annual rates up to 1500 l/tree (or 416 m³/ha) in five equal doses between November and March on the soil of an experimental olive orchard (cv. *Kalamata*). Furthermore, the possibility of groundwater pollution by the application of fresh OMW was also examined using trees grown in large lysimeters (60 m³ of soil volume) treated similarly to the field experiment. The results from the field experiments revealed that OMW treated soil had higher potassium and phenols content which were decomposed rapidly in the soil, while toxicity symptoms were not observed in the olive trees. The results from the lysimeters confirmed the field experiment data. Although these findings are encouraging, the application of fresh OMW in olive orchards is an environmentally safe way to dispose wastewater produced by olive oil mills (Chartzoulakis *et al.*, 2006).

Vlyssides *et al.* (1996) co-composted solid residue (as bulking material), urea (as nutrient source) and OMW in a wastewater-treatment plant at 45–65°C with air supply, providing carbon/nitrogen ratio below 30/1, and OMW addition in order to maintain the moisture at 40–60% and to replace the carbon substrate (Figure 8.25). After the thermophilic period, the final product remained in the bioreactor without any influents. This mesophilic stabilization step (3 months duration) was necessary in order to ensure that the compost would be environmentally safe after its disposal. The final product proved to be a good soil conditioner, because it managed to improve both the soil ion exchange capacity and porosity. Moreover, the energy produced during the process was estimated at 376 812 000 kJ, equal to the water evaporation energy requirements plus the energy required for increasing the wastewater temperature from ambient to bioreactor temperature.

The flocculated solid fraction of OMW (FOMW), from two different olive oil extraction systems, was composted with olive leaves (OL) according to the Rutgers static pile system, with pile moisture between 40 and 60%, temperature at 55°C and ventilation 30 s every 15 min. Two blends were prepared with the following composition: mixture A; 65% FOMW₁ + 35% OL; and mixture B; 74% FOMW₂ + 25% OL + 1% urea. The results indicated high OM degradation (mainly of lignocellulosic compounds) up to 60% in mixture A, due to the high initial C/N ratio, and 38–39% in mixture B while, in both mixtures, most of the fat was degraded. On the other hand, mixture B was more effective for composting than mixture A, due to the water-soluble organic carbon content, C/N ratio and the urea supplied as a nitrogen source, as the former had a shorter composting time and developed a microbial population with a high metabolic activity faster than the latter (Garcia-Gomez *et al.*, 2002b).

The composting of olive press cake repeatedly mixed either with OMW or with tap water was studied by Mari *et al.* (2003). The composting lasted 5 months, during which

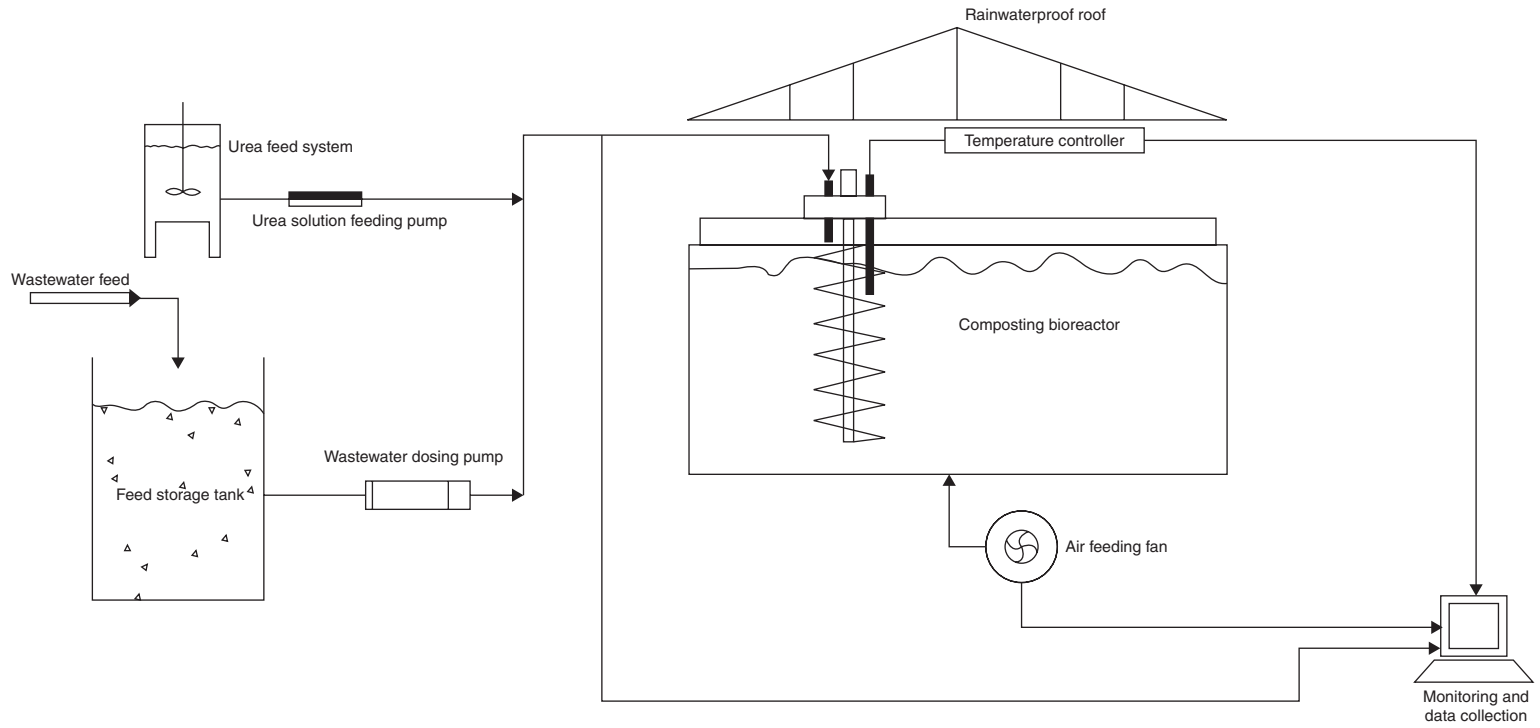

Figure 8.25 Flow diagram of composting plant (adapted from Vlyssides *et al.*, 1996)

nine moistenings of the olive press cake were carried out with OMW or tap water to ensure that water holding capacity (WHC) reached 60%, while the temperature was kept below 30°C. The respiration rates were determined at eight different temperatures (17 up to 63°C – respiration profile) by means of a thermogradient respirometer. The repeated application of OMW recurred thermophilic phases, increased pH and conductivity in the final product, as compared to water applications and caused detoxification of the materials as indicated with seed germination tests. Respiration measurements at 35°C proved to be good indicators of the mean respiration derived from the whole respiration profile over a wide range of environmental temperatures. The respiration potential of the composts at high temperatures (42–63°C) increased drastically compared to the corresponding one at lower temperatures (17–42°C), thereby indicating the establishment of a thermophilic microflora.

During 2001–2002, Montemurro *et al.* (2004) investigated the effects of untreated OMW, treated OWW and olive pomace compost on yield and nitrogen utilization of ryegrass crop and on chemical soil characteristics, as well as the potential use of these materials as amendments and their potential application on a farm scale. The OMW was treated with mineral catalyzer, while the olive pomace was co-composted with poultry manure and wheat straw in an open field at temperature 50–60°C for 40 days and 35–45°C for 150 days and moisture 50–60%. The observed increase in growth of the ryegrass plants was up to 18.2% in 2001 and 41.1% in 2002, confirming the potential use of OMW as an amendment in the ryegrass crop. Furthermore, the total, extracted and humified organic carbon and humification parameters increased considerably, while no heavy metals accumulation was recorded. Finally, the nitrogen content in OMW was used by the ryegrass for plant growth, thus increasing the nitrogen uptake and, consequently, the dry matter accumulation.

Paredes and his coworkers (2001) composted two different blends of OMW, applying the Rutgers static pile system at 55°C, moisture 40% and 30 s ventilation every 15 min. The composition of the two mixtures (C1 and C2) was as follows: C1; 0.9 l OMW/kg + 33% sewage sludge + 67% cotton gin, C2; 2.1 l OMW/kg + 22% cotton gin + 78% waste from orange juice extraction. The results showed that both composts had higher OM and N_{org} contents than the limits set by Spanish legislation for compost, lacked phytotoxicity, had high EC, lower nitrification, increased cation exchange capacity and stabilized and humified organic matter (OM), whereas the C2 compost had a lower degree of maturity than C1 compost. Composting these wastes can be considered a promising alternative for recycling of the OMW and the obtained composts can be effectively used as soil amendments.

OMW and wheat straw were blended and composted in a forced aerated static pile. The final compost was applied to maize (*Zea mays* L. hybrid line Plenus), ryegrass (*Lolium italicum*) and to two horticultural plants (*Lactuca sativa* var romana and *Spinacia oleracea* var gigante). The end product was a high quality compost, due to the presence of considerable amounts of nutrients, particularly nitrogen, mainly present in the organically-bound form, absence of heavy metals and phytotoxic effects on the applied crop, high stabilization and good level of humification (degree of humification = 78%; humification index = 0.28). The requirements for chemical fertilization were greatly reduced when the compost was applied to maize. The compost application also

enhanced the plant development especially over the first stages of the cultural cycle. When the compost was applied to ryegrass, the crop yield considerably increased and, in the case of horticultural plants, the compost proved to be of substantial help towards meeting the nutritional requirements (Tomati *et al.*, 1996).

Baddi and coworkers (2004) composted olive marc, wheat straw and OMW for a year and the produced pile was aerated every 15 days and homogenized. After 10 months a decrease of 97% and 66% was recorded for lipid and water-soluble phenol content, respectively. Furthermore, organic matter (OM) losses were higher over the first 3 months of the process, while lignin degraded less (43.8%) than cellulose (58%) and hemicellulose (76%). An increase in nitrogen and ash content was reported, whereas a decrease in organic carbon was recorded. The final product was rich in stabilized organic matter and, in view of its being toxicity free, can be utilized as soil amendment or organic fertilizer.

The effect of burned olive waste on soil properties (unconfined compressive strength, swelling pressure and maximum dry density) was studied by Attom and Al-Sharif (1998). The solid olive waste was burnt at 550°C and then mixed with four soil samples with different plastic index at four different percentages (0.0%, 2.5%, 5.0%, 7.5% w/w). The results showed that the burned olive waste reduced the soil plasticity, especially when the plastic index was high. An addition of 2.5% of the burned olive waste by weight to soil resulted in an increase in the maximum dry density and unconfined compressive strength. However, employment of higher percentages of burnt olive waste led to a decrease of both the maximum dry density and the unconfined compressive strength of the soil. The addition of 7.5% of the olive ash by weight also decreased the soil swelling pressure. It was concluded that the burnt material can be effectively used as stabilizer, thus resolving many of the problems associated with its accumulation.

OMW, obtained from a three-phase mill, was mixed with rock phosphate and the blend was used as a fermentation medium in batch and repeated-batch experiments. The fermentation process was carried out in an air lift reactor that was fed with the above blend and *Aspergillus niger* spores at 30°C for 8 days. The fungi reduced the COD of OMW by 35% and 64% in the batch and repeated-batch experiments, respectively. In batch experiments, the total phenol reduction was negligible, whereas total sugars were reduced up to 60%. On the other hand, in repeated-batch experiments, total sugars and phenol removal was up to 59% and 10%, respectively. Among the different types of the mixture of OMW and rock phosphate applied to greenhouse soil in order to be tested as fertilizer in wheat (*Triticum durum* Desf.), only the mixtures treated in batch experiments could be effectively used as fertilizer. Application of the latter displayed considerable increase in seed biomass, spike number and kernel weight, however, the harvest index reached its highest value (0.49 ± 0.04) after treatment of OMW in repeated-batch process (Cereti *et al.*, 2004).

Vassilev and his coworkers (1997a) treated OMW with immobilized cells of fungus *Aspergillus niger* (strain NB2) in order to produce a material with low toxicity. The OMW, obtained from centrifugation for the mechanical extraction of olive oil, was mixed with ammonium sulfate or rock phosphate or ammonium sulfate and rock phosphate, and used as a medium in a shake-flask repeated-batch fermentation (30°C, 200 rpm) with *Aspergillus niger* immobilized on polyurethane sponge. The results

indicated that *A. niger* was capable of reducing COD and total phenols from 6 g/l down to 2 g/l. The liquid waste produced was considered a potential candidate for use in plant growth.

OMW blended with magnesium (Mg) in the presence of nitrogen was used as a medium in a shake-flask, repeated-batch fermentation process with a passively immobilized, acid-producing strain of *Aspergillus niger* (strain NB2). The fermentation and immobilization processes were carried out at 30°C and at 200 rpm. The fungus *A. niger* reduced pH by one unit and the phenolic content of OMW dropped down to 36–59% of the initial amount. The OMW was then mixed or not with rock phosphate and the blend was effectively used as an amendment to the soil, where seeds of *Trifolium repens* were planted. The results demonstrated a slight plant growth increase irrespective of whether OMW was enriched or not with rock phosphate, thus corroborating its use as a fertilizer (Vassilev *et al.*, 1998).

Chatjipavlidis *et al.* (1996) constructed a pilot plant in an attempt to treat OMW effectively. The OMW was first pretreated with hydrogen peroxide (H₂O₂) under alkaline conditions for 6–12 hours until the pH was stabilized at 8. Then the mixture was transferred into a bioreactor in the presence of *Azotobacter vinelandii* (strain A and others) and the process lasted from 3 to 7 days. The product of this bioremediation process turned out to be a thick, yellow, non-phytotoxic liquid, with a slightly alkaline pH, 7.5–8.0, containing exopolysaccharides, major and trace plant nutrients and nitrogen in organic forms and can be used as an organic soil conditioner (bio-fertilizer).

Kotsou *et al.* (2004) applied untreated OMW and bioremediated OMW to soil using the bacterium *Azotobacter vinelandii*, in order to examine the soil suppressiveness against the plant pathogen *Rhizoctonia solani*. OMW, obtained from a centrifugal olive mill, was treated aerobically by means of a strain of the diazotroph *A. vinelandii* in a rotating biowheel type reactor for 5 days. A sandy silt soil was treated with OMW (untreated and bioremediated with *A. vinelandii*) and inoculated with *R. solani*, while lettuce seeds were planted, in an attempt to monitor the soil suppressiveness. Employment of untreated and bioremediated OMW led to an enhancement of the respiratory activity of soil microorganisms, due to the organic load of the OMW that was removed during its aerobic treatment. The phytotoxic effect was probably due to the formation of unstable organic matter from the wastewater added. The recorded considerable disease suppressiveness against *R. solani* for lettuce seeds in both treatments was attributed to the shift in the soil microbial community from K- to r-strategy.

Piperidou *et al.* (2000) examined the ability of *Azotobacter vinelandii* to grow in OMW and convert it into organic liquid fertilizer and soil conditioner. OMW was first treated with calcium hydroxide and then transferred into a bioreactor, a repeated fed-batch culture system, where it mixed with *Azotobacter vinelandii* (strain A) for 3 or 7 days. According to the results, the reported phosphorus remained stable and nitrogen in its ammonium form increased over the process. Phenols decreased by 66–99% after 3 days and 100% after 7 days (some of them), while sugars degraded to a great extent after 3 days. The end product displayed low phytotoxicity and could be potentially used as fertilizer.

Marques (2001) treated anaerobically a mixture of diluted OMW and piggery effluent (original or anaerobically digested) with the aim to investigate the potential use of the

obtained effluent for soil irrigation. Two up-flow anaerobic filters were fed with the above mixtures with hydraulic retention time (HRT) 6–7 days and temperature at $35 \pm 1^\circ\text{C}$. The results suggested that OMW maintained its black color due to polymerization of aromatic molecules into polymers of higher molecular weight not readily biodegradable (Saiz-Jimenez *et al.*, 1986; Perez *et al.*, 1987). Seventy to 80% of the influent COD ($20\text{--}60\text{ kg COD m}^3$) was converted into biogas and the final effluent had neutral/basic pH and was found to be perfectly safe and suitable for agricultural irrigation.

OMW, derived from a discontinuous olive oil processing plant, was pretreated aerobically with white rot fungi *Phanerochaete chrysosporium* DSM 6909 in a stainless steel air lift reactor composed of a bubble column reactor equipped with a draft tube. The pretreated OMW was fed into an anaerobic filter reactor for 6 months at 37°C , while composition of released gas was quantitatively determined with gas chromatographer (GC) and the produced liquid was ultrafiltered (Figure 8.26). A toxicity reduction

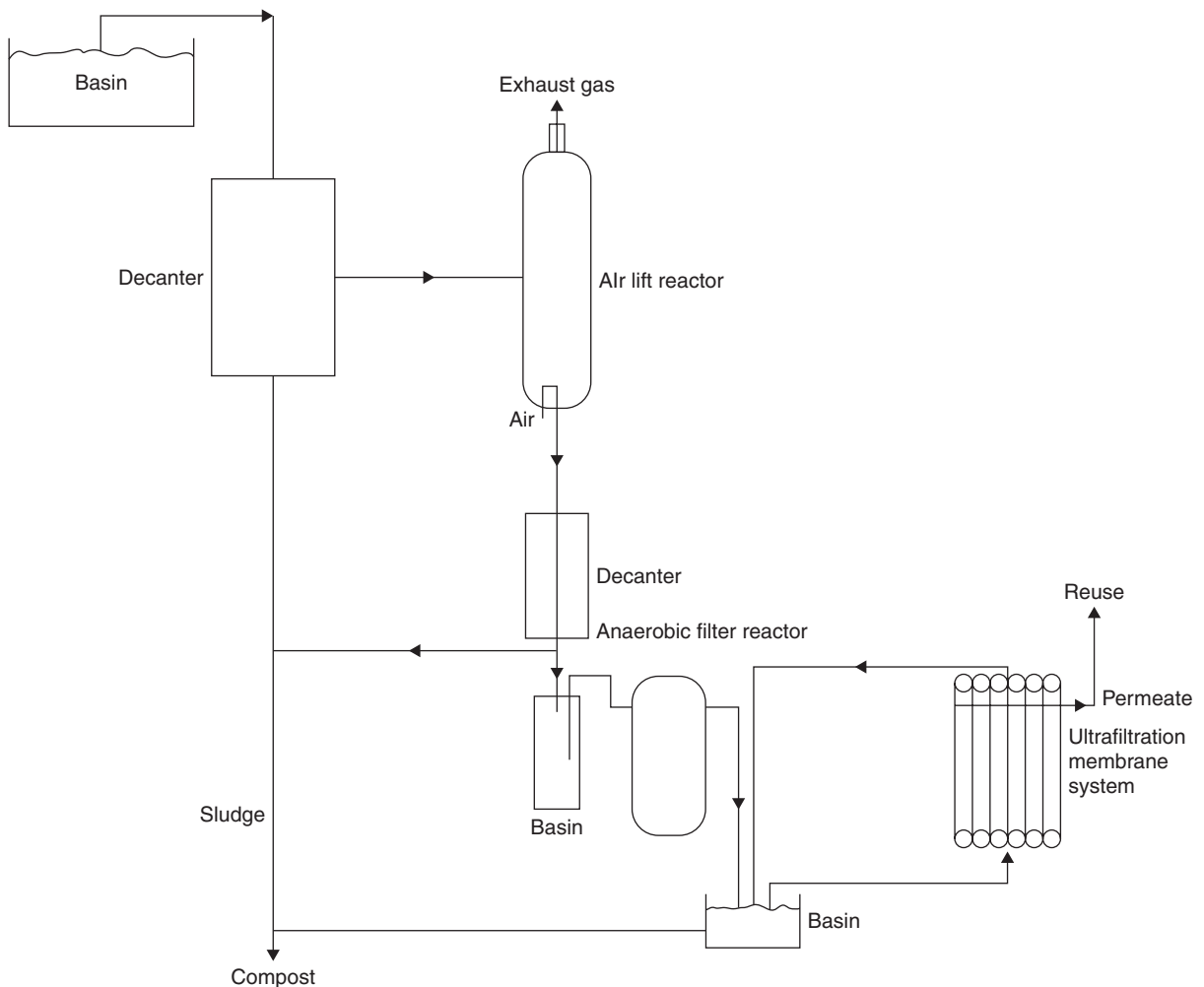

Figure 8.26 Integrated process diagram (adapted from Dhouib *et al.*, 2006)

up to 26% was recorded in the OMW due to the aerobic pretreatment, while after the aerobic–anaerobic treatment, the OMW was rich in nutrients, was pathogen-free, less toxic and contained low concentrations of heavy metals. Ultrafiltration of the liquid obtained from the anaerobic digestion resulted in decolorization and reduction in COD and toxicity. Treated OMW was used for irrigation after field tests, because it greatly promoted both plant growth and germination index (GI) of *Lycopersicon esculentum*. The released methane was utilized as an energy source for the needs of a small olive mill (Table 8.6) (Dhouib *et al.*, 2006).

Capasso *et al.* (2002) examined the potential exploitation of polymerin, a dark and complex metal polymeric organic mixture recovered from OMW, in agriculture and in environmental biotechnology processes. OMW samples, obtained from a pressure processing plant, were first centrifuged for 30 min, filtered and the produced solution was concentrated, treated with cold methanol (-20°C) and finally lyophilized. The remaining black residue, called polymerin, consisted of carbohydrates (52.40 mg/100, w/w), melanin (26.14 mg/100), proteins (10.40 mg/100), monosaccharides, phenols, amino acids, metals (11.06 mg/100), Mg^{2+} , Zn^{2+} , Fe^{3+} , Cu^{2+} and cations (K^{+} , Na^{+} , Ca^{2+}). Polymerins can find applications in agriculture as bioamendments and macro- and microelement biointegrators and as a biofilter for toxic metal removal, as they have many similarities with humic acids.

Raw OMW and olive press cake (OPC), derived from a three extraction phases/continuous olive oil mill plant, were stored at -20°C and then used as substrates for the cultivation of mushrooms of two *Pleurotus* species, *P. eryngii* LGAM P63 and *P. pulmonarius* LGAM P46. Four different OPC-media were prepared using plain water and supplemented with 12.5%, 25% or 50% OMW. All substrates were inoculated with the above *Pleurotus* strains and then incubated at 23°C in the dark. Cultivation characteristics related to mushroom production, such as earliness, yield, biological efficiencies and quality of basidiomata were also recorded. OPC proved to be a suitable substrate for the production of high quality mushrooms (shape, color, form, flavor and taste). *P. pulmonarius* strain exhibited better earliness values, while *P. eryngii*

Table 8.6 Evolution of the methane yield during methanization of untreated and treated OMW

Biogas production			
Untreated OMW		Treated OMW	
Time (days)	Biogas (l/day)	Time (days)	Biogas (l/day)
0	2	30	400
10	4	50	600
20	4.5	70	650
30	6	90	720
40	4.5	110	900
50	4.5	130	900
60	4	150	900

Adapted from Dhouib *et al.*, 2006

produced basidiomata in high yields and of excellent quality. OPC supplemented with low concentrations of OMW (12.5%) promoted fungal colonization rates and mushroom yield, but higher concentrations, inhibited mycelial growth. The optimal concentrations of OMW for the two *Pleurotus* species amounted to 25–50% (Zervakis *et al.*, 1996).

An integrated strategic method for the decontamination of OMW originated from from three-phase olive oil extraction was investigated by Vlyssides *et al.* (2004). The produced OMW were treated with the implementation of a Fenton oxidation process ($\text{Fe}^{+2} + \text{H}_2\text{O}_2 \rightarrow \text{Fe}^{+3} + \text{OH}^-$), followed by a biological treatment (aerobic reed beds). OMW were detoxified, while valuable antioxidant products were obtained. Furthermore, the solid waste was collected and composted in an attempt to produce high quality compost that can be utilized as organic fertilizer/soil conditioner.

OMW was centrifuged at 4000 rpm for 10 min in an attempt to remove the suspended solids (SS) causing membrane fouling from the wastewater and then the centrifuged supernatant was ultrafiltrated through a polysulfone flat membrane at 30°C. The results indicated a substantial reduction in ashes and SS up to 80%, while the COD decrease reached 90%. The ultrafiltration permeate, particularly the organic fraction, contained sugars (2–12 g/l) and polyphenols (0.2–0.3 g/l) that can find applications in the pharmaceutical field and in food preserves due to their antioxidant properties. On the other hand, a phenol reduction was observed in the retentate, thus resulting in its use as a fertilizer after an enzymatic treatment for the production of humic substances (Turano *et al.*, 2002).

The organic fraction of OMW contained sugars, tannins, polyphenols, polyalcohols, pectins and lipids; among them sugars and polyalcohols were very good carbon and energy sources for microorganism growth. Kalmis and Sargin (2004) used wheat straw and OMW as substrates for the cultivation of two *Pleurotus* species, *Pleurotus sajor-caju* and *P. cornucopiae* var. *citrinopileatus*. Wheat straw was moistened with OMW:tap mixtures containing 25%, 50% or 75% OMW (by volume), or undiluted OMW, mixed with wheat bran and sterilized at 121°C for 45 min. The above substrate was inoculated with the *Pleurotus* strains and incubated at $25 \pm 1^\circ\text{C}$ with relative humidity $85 \pm 5\%$. The mixtures containing 25% and 50% OMW were found to be suitable for cultivation of both *Pleurotus* strains.

The potential use of alpechin, a liquid waste from the three-phase decanters and presses, and its sludge for agricultural purposes was investigated by Paredes *et al.* (1999). Alpechin and OMW sludges, obtained from evaporation ponds, were blended and stored at 4°C, prior to analysis. The dry matter of OMW sludges was significantly higher than that of alpechin, while no significant differences were reported in pH, EC, OM and TOC. The sludges had higher levels of total nitrogen (TN), Ca and micronutrients, but lower levels of potassium than that of alpechin. These wastes can be used as organic fertilizers in soils for the improvement of soil fertility.

OMW from an olive oil production plant was lyophilized and the obtained sludge was mixed with soil and incubated at $25 \pm 2^\circ\text{C}$. The main results of this OMW treatment were decomposition of toxic organic compounds, increase of exchangeable potassium and reduction in the soil nutrient anion levels. A germination test of *Lepidium sativum* was carried out to investigate the phytotoxic effects of the OMW sludge. The results

revealed that 20 days after sludge application, even if the highest dose was applied to soil, no toxicity was reported. It was therefore concluded that OMW sludge can be most effectively employed for decomposition of toxic organic compounds, thereby leading to an increase in exchangeable potassium and reduction in the soil nutrient anion levels (Riffaldi *et al.*, 1993).

Biogas/biodiesel/hydrogen production

The diesel fuel consumption in developed countries has been continuously increasing over the past decades and is expected to continue further in the future. A promising alternative to fossil fuels is the use of biodiesel (Strub, 1984). More than 100 years ago, Rudolph Diesel tested vegetable oil as the fuel for his engine (Shay, 1993). Biomass used for energy production occupies a special place among renewable energy sources and is estimated to contribute 10–14% of the world's total energy supply. Biomass energy can be effectively used to generate electricity and heat, or economically competitive liquid transportation fuels for motor vehicles (Bridgewater and Grassi, 1991; Chum and Overend, 2001; McKendry, 2002). Among the agricultural residues, straws, nut shells, fruit shells, fruit seeds, plant stalks, stovers, green leaves and molasses were shown to be renewable energy resources of added value (Zhang and Zhang, 1999). Biomass thermo-chemical conversion technologies, such as gasification, pyrolysis and combustion are currently being used for the world's bio-energy production (Figures 8.27, 8.28, 8.29, 8.30).

Zabaniotou and Karabelas (1999) designed a plant for the pyrolysis of forestry biomass and, in particular, *Arbutus unedo*, an evergreen broad-leaf tree in Greece. Other agricultural wastes that can be fed to this plant are olive pits and cuttings. The pyrolysis was carried out in a laboratory 'captive sample' reactor at 400–700°C, with heating rates 120–165°C/s, at atmospheric pressure, under nitrogen. The pyrolysis products were pyrolytic gas, bio-oil and charcoal. The calorific value of charcoal is similar to commercial type and, via briquetting, it can be further upgraded and distributed to the local market. In the case of bio-oil, a highly oxygenated hydrocarbon mixture of water and organic acids, a further investigation for its use is required.

The energy characteristics of the exhaust foot cake were investigated by Masghouni and Hassairi (2000). The solid waste was combusted in a static furnace of a brick factory with an adapted burner at $850 \pm 10^\circ\text{C}$, $570 \text{ Nm}^3/\text{h}$ combustion airflow, 23°C combustion air temperature and 40% relative humidity. The results suggested that the exhaust foot cake can be used instead of heavy fuel No. 2 (<http://www.dieselnet.com/standards/fuels/us.html>), while the cost of the energy reduced up to 64%.

OMW and olive husk were thoroughly mixed and the blend was fed to a rotary dryer to reduce the moisture from 69% to 15% and utilize the produced hot gases. The dried blend was then fed to a gasifier and the released gas was fed to a combined gas-stream cycle, or gas turbine cycle, or internal combustion engine in order to produce a low heating value gas (5860 kJ/kg). In another experiment, the dried mixture of OMW and olive husk was combusted in a boiling atmospheric fluidized bed combustor. The released fumes were fed into a steam generator, where the produced steam

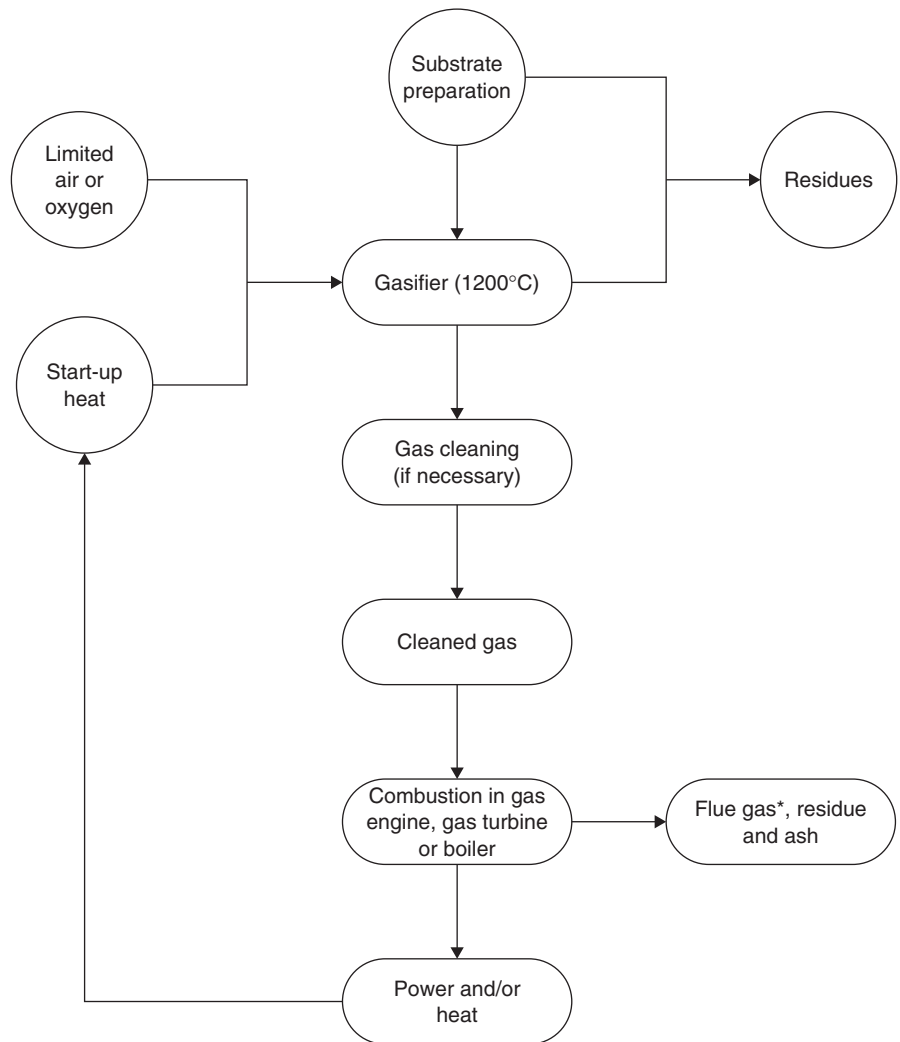

Figure 8.27 The gasification process (adapted from http://www.esru.strath.ac.uk/EandE/Web_sites/01-02/RE_info/biomass.htm; <http://www.wasteresearch.co.uk/ade/efw/gassification.htm>; Arvanitoyannis and Kassaveti, 2007).

* Flue gas: gas that exits to the atmosphere via a flue, which is a pipe or channel for conveying exhaust gases for a fireplace, furnace, boiler or generator (<http://www.en.wikipedia.org/wiki/Flue-gas>)

could be effectively used for the generation of electric energy. Another combustion method was also proposed for the blend by using a conventional boiler and steam turbine cycle. The mixture was dried in a rotary dryer until the moisture was reduced down to 10%, fed to a boiler and the resulting steam was placed in a steam turbine cycle. The results revealed a considerable energy recovery by treating both olive husk and OMW of olive mill industries (Caputo *et al.*, 2003).

The potential use of olive cake as a source of energy was investigated by Alkhamis and Kablan (1999). Olive cake with initial moisture content 30% was dried in a

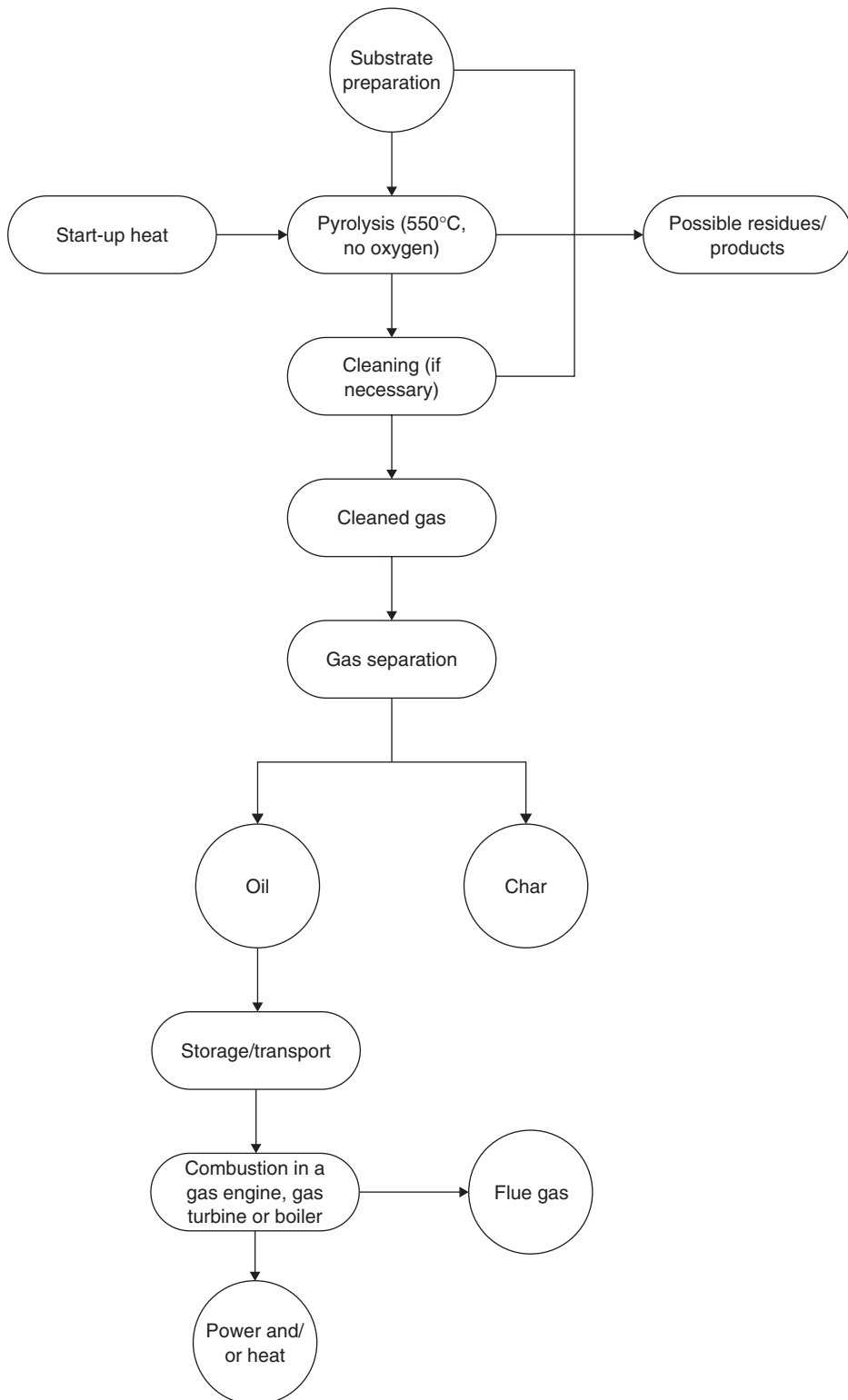

Figure 8.28 The pyrolysis process (adapted from <http://www.wasteresearch.co.uk/ade/efw/gassification.htm>; http://www.esru.strath.ac.uk/EandE/Web_sites/01-02/RE_info/biomass.htm; http://www.intuser.net/6/1/renew_37.php; Arvanitoyannis and Kassaveti, 2007)

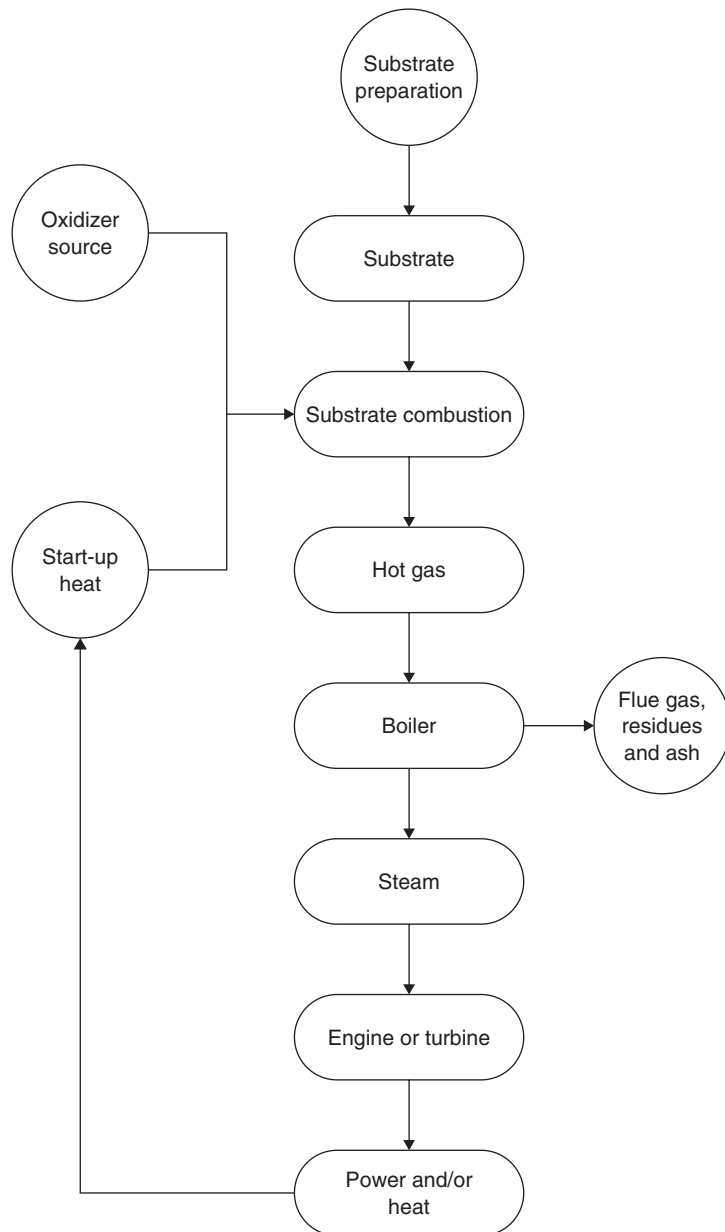

Figure 8.29 The combustion process (adapted from http://www.esru.strath.ac.uk/EandE/Web_sites/01-02/RE_info/biomass.htm; <http://www.grc.nasa.gov/WWW/K-12/airplane/combst1.html>; Arvanitoyannis and Kassaveti, 2007)

general purpose oven for 1 h at 105–110°C, ground in a mill for particle size reduction and mixed at different percentages $0\pm 90\%$ weight with particles of oil shale. The results suggested that the olive cake can be used as an excellent source of renewable energy (average calorific value 31.2 kJ/g) and as a catalyst to oil shale combustion, due to the calorific value of the mixture (13.2–31.2 kJ/g). In blends of high olive cake

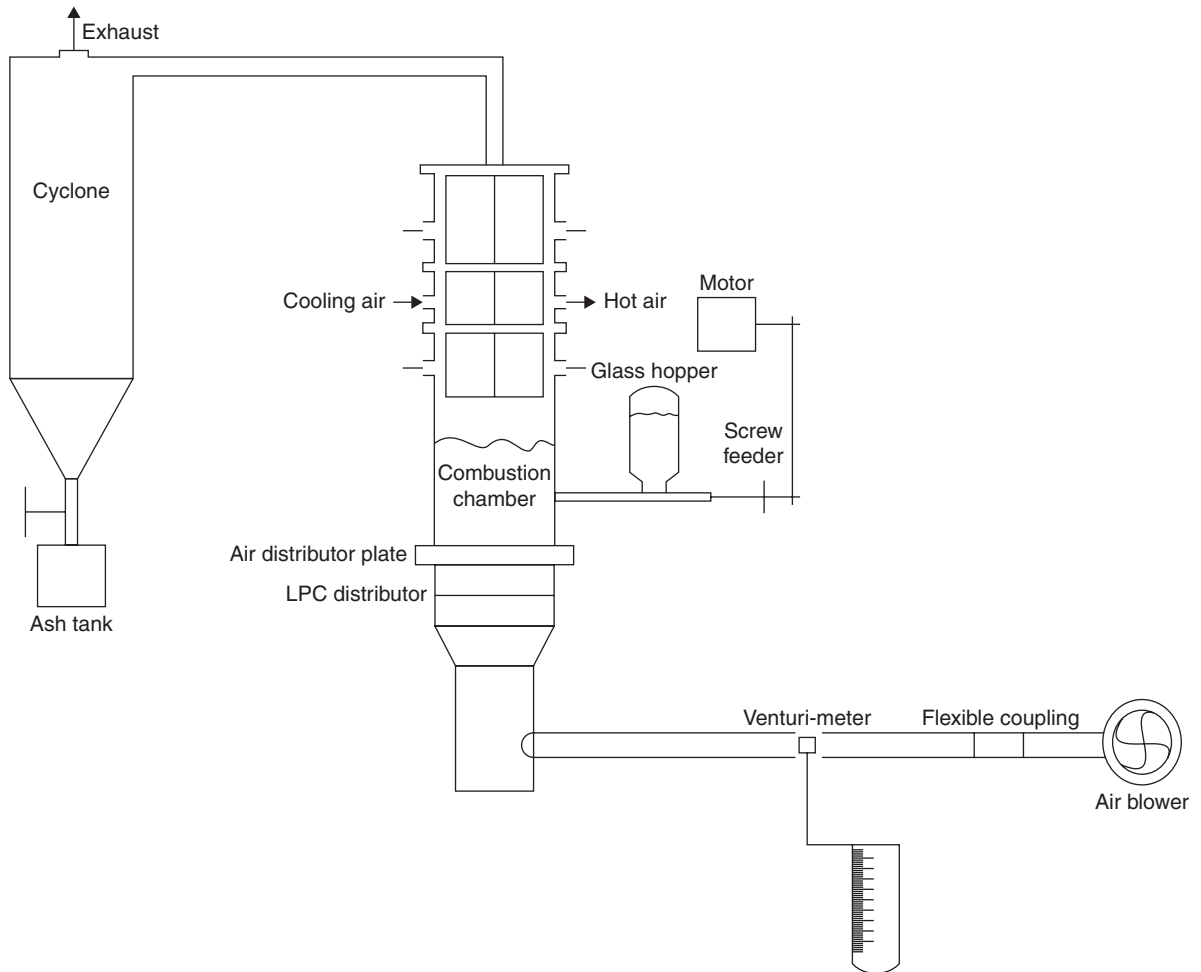

Figure 8.30 Schematic of the combustion process of olive cake (adapted from Abu-Qudais, 1996)

content ($90 \pm 100\%$ olive cake) complete combustion occurred, whereas in other samples of mixtures ($10 \pm 30\%$ olive cake) combustion was not complete. It was therefore concluded that direct mixing of olive cake with oil shale without any further processing is not suitable for direct combustion.

Exhausted olive oil husks were pyrolyzed in a continuous feed reactor at pressure slightly above atmospheric (103–104 kPa) and at nitrogen atmosphere. The pyrolyzer was operated at 702°C during all runs, while the cracking temperature was varied between 700 and 902°C . The results showed that an increase in temperature in non-catalytic runs decreased the total tar content. Furthermore, thermochemical treatment of the exhausted olive oil husks produced a relatively low yield of hydrogen (H_2) (0.24–0.30 mol/kg dry exhausted olive husks). The effect of calcined dolomite was to increase the hydrogen yield (0.90–1.20 mol/kg dry exhausted olive husks) by decreasing the tar yield (Taralas and Kontominas, 2006).

Topal and coworkers (2003) burned olive cake and lignite coal in a circulating fluidized bed (CFB) at 900°C under various excess air ratios ($\lambda=1.1-2.16$) to investigate the combustion characteristics of this waste and compare them with coal. The analysis of flue gas showed that it contained O₂, CO, CO₂, SO₂, NO_x and hydrocarbons. The combustion efficiency of olive cake ranged between 82.3 and 98.7%, while the maximum combustion efficiency of coal reached 98.3%. The calorific value of coal was 22 000 kJ/kg, very close to the calorific value of olive cake. The ash formed during the olive cake combustion contained Na₂O, non-harmful metal oxides, so it can be used as fertilizer. These results suggested that olive cake is a potential fuel that can be utilized for clean energy production in small-scale industries by using CFB.

Putun and coworkers (2005) conducted three pyrolysis experiments with olive residue in a stainless steel fixed-bed reactor. The first experiment was carried out under normal atmosphere and the final temperatures were in the range 400–700°C; in the second, nitrogen was used as a sweeping gas with various flow rates of 50–400 m³/min; in the third, steam was applied to the raw material with different air velocities (0.6–2.7 cm/s). The pyrolysis products were char (Figure 8.31), gas and a liquid (bio-oil), consisting of an aqueous and an oil phase. The bio-oil production increased up to 19.13% wt when the flow rate of nitrogen was 100 cm³/min, the maximum bio-oil yield was reported when the olive residue was treated with steam and the air velocity was 1.3 cm/s and oil yield was found to be 27.3% at final temperature 500°C. Char, gas and bio-oil can be effectively used as fuel, while the liquid product of pyrolysis can be added to petroleum refinery feedstocks or upgraded by catalysts to produce premium

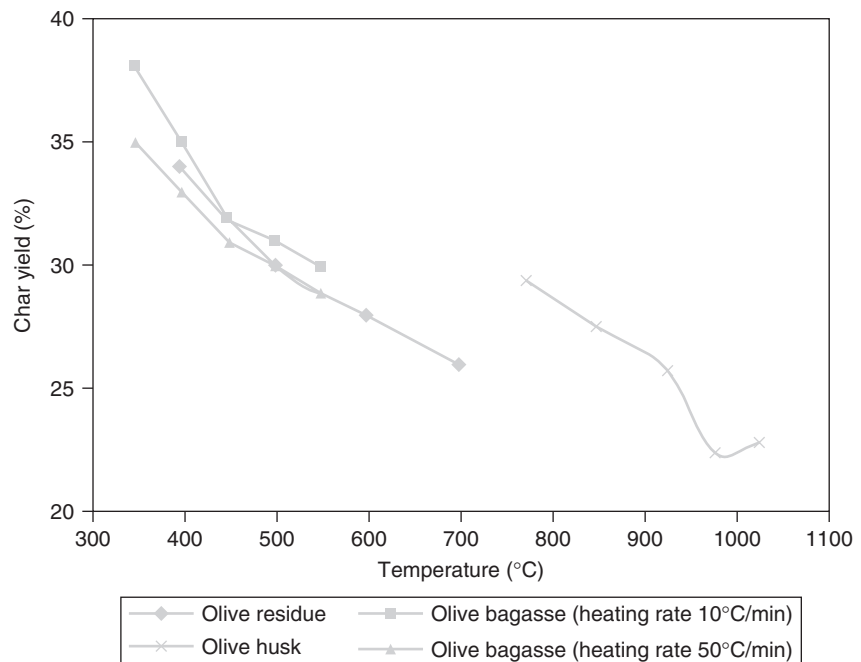

Figure 8.31 Char yield of pyrolysis products at various temperatures (adapted from Caglar and Demirbas, 2002; Putun *et al.*, 2005; Sensoz *et al.*, 2006)

grade refined fuels, or may have a potential as chemical feedstocks (Bridgewater and Grassi, 1991; Williams and Besler, 1993; Encinar *et al.*, 2000).

Various mixtures of olive cake (25, 50 and 75 wt %) and lignite coal were co-combusted at 700°C in a circulating fluidized bed (CFB) with various excess air ratio (from 1.1 to 2.2). The combustion efficiency ranged between 96.3 and 98.5%. The mixture of olive cake and lignite coal can be used as fuel for cleaner energy production in small-scale industries by means of CFB. The mixing ratio of olive cake to lignite coal should be below 50 wt % in order to lie within the limits set for emissions by the EU. The minimum emissions were recorded when the excess air ratio reached the level of 1.5 (Atimtay and Topal, 2004).

Olive bagasse, with particle size 0.425–0.600 mm was pyrolyzed in a stainless steel tubular reactor with a sweep gas (nitrogen), heating rates 10 or 50°C/min and temperature at 350, 400, 450, 500 and 550°C. The obtained bio-oil was characterized by lower oxygen content (21.9%) than that of the original feedstock (37.5%), presence of oxygenated fractions such as carboxyl and carbonyl groups produced by pyrolysis of the cellulose and phenolic and methoxy groups produced by pyrolysis of the lignin. The bio-oil consisted of aromatic and aliphatic hydrocarbons, with heating value of 31.8 MJ/kg, close to those of petroleum fractions and was successfully used as a fuel and chemical feedstock (Sensoz *et al.*, 2006).

Bacaoui *et al.* (2001) prepared a mixture of olive pulp and stone for the production of activated carbon and studied the potential use as adsorbents in aqueous solutions. The raw material was carbonized in a stainless steel autoclave and heated at 400°C for 1 hour under a nitrogen flow and activated in a thermolyne silica electric oven with a temperature control device linked to a thermocouple at 750–850°C for 30–70 min. The produced activated carbon was boiled for 30 min in distilled water, dried, ground, sifted and dried again at 110°C. The optimal conditions for the production of activated carbon suitable for removal of pollutants from liquid phases (water) were found to be activation time and activation temperature 68 min and 822°C, respectively.

Olive husk samples were pyrolyzed in a stainless steel cylindrical reactor with or without the presence of catalysts, such as ZnCl₂, Na₂CO₃ or K₂CO₃ at different temperatures (502, 577, 652, 702 and 752°C). A pyrolytic gas (mixture of CO, CO₂, olefins + O₂, H₂ + paraffins, gases) was obtained and its yield in both experiments (with or without catalysts) enhanced with increase in temperature. The highest hydrogen rich gas yield was 70.6% and was obtained by using 13% ZnCl₂ at 752°C, while hydrogen yield from the other catalysts was 62.9% and 62.6 % by Na₂CO₃ and K₂CO₃, respectively. The hydrogen yield increased when ZnCl₂ was employed as catalyst, but the yield of pyrolytic gas decreased when the yield of charcoal and liquid products increased. Hydrogen gas produced from olive husk by direct catalytic pyrolysis can be used as fuel for internal combustion engines in automobiles (Caglar and Demirbas, 2002).

Briquetting experiments were performed on olive refuse (moisture content 7.5%) by using a hydraulic press under pressures of 150, 200 and 250 MPa and the produced briquettes were stored under ambient conditions for a week prior to testing their mechanical properties and water resistance. The results indicated that the maximal compressive strength was recorded at 150 MPa. At 200 MPa, the shatter index reached the highest value and the water resistance further improved with increase in briquetting pressure.

A fibrous biomass material, such as paper mill waste, was added to the olive refuse waste, in order to increase the mechanical strength and the mixture was briquetted under 200 MPa pressure. The shatter index of this briquette was found to be 4813, compressive strength amounted to 31.28 MPa and water resistance time was determined at 27 min. The produced briquettes were of good quality and can be used as an alternative energy source (Yaman *et al.*, 2000).

Walid (2001) dried olive cake for 1 h at 100°C, separated the seeds from the initial sample and carbonized them in a sealed crucible at various temperatures (400, 600, 800°C) for 1 h. Olive seed activated carbon was more effective at 800°C than commercial type carbon, while the adsorption capacity of fresh activated carbon at 800°C was found to be higher than the others, followed closely by regenerated activated carbon and commercial type.

Vegetation waters (VW), obtained from a traditional extraction process and a continuous extraction system, were concentrated with evaporation. The condensed residues with olive husk, coming from a traditional extraction process, were both dried at 105°C prior to pyrolysis (200–550°C). The final products were char (solid residue), tar (heavy organic fraction), a liquid phase (oil and water) and an uncondensed gaseous fraction (CO₂, H₂, CO, CH₄, C₂H₆ from VW and CO₂, H₂, CO, CH₄ from olive husk). The VW residues and the olive husk could be used as a fuel to provide heat in the evaporation stage (Vitolo *et al.*, 1999).

Ganan *et al.* (2006) focused on the re-design of a gasification plant for the production of activated carbon from biomass residues, for the energetic exploitation of the combustible gases produced during the pyrolytic process (H₂, CO, CH₄, C₂H₂, C₂H₄, C₂H₆) since these gases are currently burnt in a torch in the plant. The idea of designing the activated carbon production plant arose from the need to manage the biomass residues (olive wastes). The production of this residue is 250 tons/day, which involves an annual production of 87 500 tons of residues that have to be removed. The activated carbon production plant, already built, has a processing capacity 250 kg/h of residual biomass, with a yield close to 16% in carbon production. According to the plant capacity and the generated gases potential, a thermal power of 1.05 MW and, considering a process global output of 25%, an electric power of 250 kW would be obtained.

Eroglou and coworkers (2004) used OMW as a sole substrate for the production of hydrogen gas with *Rhodobacter sphaeroides* O.U.001. The bacterium was grown in diluted OMW media, containing OMW concentrations between 20% and 1% in a glass-column photobioreactor at 32°C. The released gas was nearly pure hydrogen, which can be utilized in electricity producing systems, such as fuel cells. The maximum hydrogen yield (145 ml) was obtained with 3% and 4% OMW concentrations. However, as well as hydrogen production, COD, BOD and phenol reduction from OMW were recorded. On the other hand, the color intensity did not undergo any change but, in contrast, increased by 74%. To be more specific, COD, BOD, phenolic content and CO₂ decreased from 1100 to 720 mg/l, 475 to 200 mg/l, and 2.32 to 0.93 mg/l, respectively. During the experiment, by-products of added value, such as polyhydroxybutyrate (PHB) (60 mg/l OMW) and carotenoids (40 mg/l OMW), were determined as well.

Batchwise and semi-continuous digestion runs of olive pomace were carried out under anaerobic conditions with the temperature maintained at 37 ± 0.5°C (Figure 8.32).

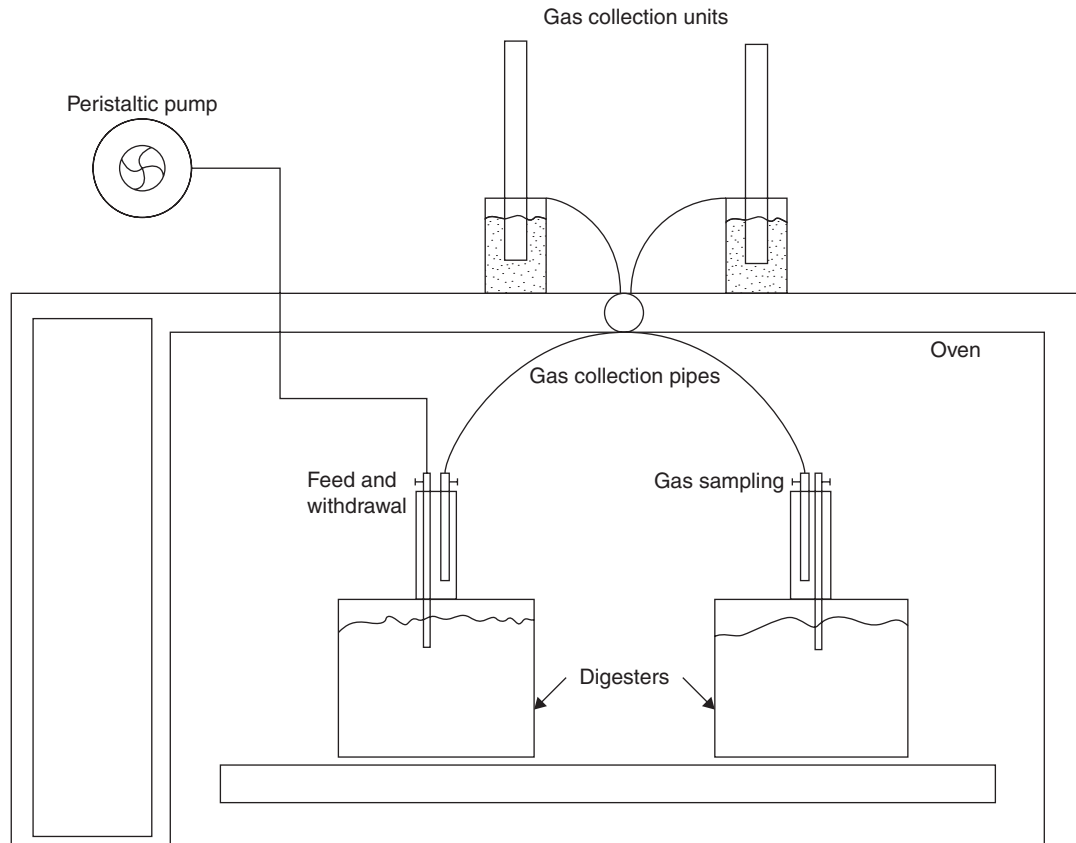

Figure 8.32 Experimental set-up for batch and semi-continuous anaerobic digestion of olive pomace (adapted from Tekin and Dalgic, 2000)

Batchwise anaerobic digestion was carried out using slurry (olive pomace and water) with total solids (TS) concentrations from 5 up to 15% and inoculum, supplied from a local landfill area. Two semi-continuous digestion experiments were performed. In the first experiment, the TS content of slurry was 10% and the hydraulic retention time (HRT) varied, whereas in the second, the TS content of slurry ranged from 5 to 15% and the HRT was 30 days. The results indicated that the methane content of the biogas amounted to 75–80% of the total biogas by volume for both batch and semi-continuous runs and the remaining gas was principally carbon dioxide (CO₂). The maximum methane production corresponded to an HRT of 20 days and 10% TS during the semi-continuous digestion. The produced methane had a medium calorific value and could be utilized as a substitute natural gas (Tekin and Dalgic, 2000).

Waste olive oil collected from hospital kitchens was preheated at different temperatures and then KOH (as catalyst) and methanol were added. The transesterification process was conducted while heating and stirring the abovementioned mixture at 1100 rpm. After the blend settled, two separate phases were formed; the upper consisted of biofuel, which was extracted and purified using distilled water and then dried over

anhydrous Na_2SO_4 ; and the lower comprised glycerol, catalyst and some impurities. The optimal conditions of transesterification for maximum ester yield (94%) were 1.3% KOH, 12% methanol, 1 min of stirring with 90 min of pour-off time, 11.4% distilled water at 25°C and drying over 0.5% Na_2SO_4 . A short-term engine performance test was carried out in a diesel engine and showed no differences between diesel fuel or biodiesel from used olive oil (Dorado *et al.*, 2004). Biodiesel, a fuel that can be made from renewable biological sources such as vegetable oils or animals fats, has been recognized recently as an environment friendly alternative fuel for diesel engines (Figure 8.33). A study comparing exhaust emissions from in-use heavy trucks fueled with a biodiesel blend with those from trucks fueled with petroleum diesel was conducted. The biodiesel blend tested is a mixture of 35% biodiesel and 65% petroleum diesel, a blend designated as B35. The study is based on the field test results from West Virginia University's Transportable Heavy Duty Chassis Dynamometer Emissions Testing Laboratory and sponsored by the US Department of Energy. The heavy trucks tested performed well when the originally equipped compression-ignition engine (diesel engine) was fueled with B35 without any engine modifications. Fuel economy (in terms of gallon per mile) of the two fuels was about the same. The emission test results showed that the heavy trucks fueled by B35 emitted significantly lower particulate matter (PM) and moderately lower carbon monoxide (CO) and hydrocarbon (HC) than the same trucks fueled by No. 2 diesel (D2). Oxides of nitrogen (NO_x) emissions from B35 and D2, however, were generally at the same level. Emissions variations from two different engine models and two driving cycles were also observed. Although more tests for biodiesel vehicles were recommended, the data obtained indicated that biodiesel is promising as an emissions-reducing alternative fuel for diesel engines (Wang *et al.*, 2000). Dorado *et al.* (2003a) conducted an emission test of a diesel direct injection engine fueled with biodiesel, obtained from waste olive oil after transesterification (Dorado *et al.*, 2004), at several steady state operating conditions. The results suggested that when biodiesel was used as a fuel, lower emissions of CO (58.9%), CO_2 (8.6%), NO (37.5%) and SO_2 (57.7%) were reported. Dorado *et al.* (2003b) used biofuel produced through transesterification (Dorado *et al.*, 2004), within the frame a 50-h short-term performance test in a diesel direct-injection Perkins engine of 8–15 kW and 1800–2100 rpm. Biodiesel properties were very similar to those of heavy fuel diesel No. 2, while a slight power loss (<8%) and an increase in brake-specific fuel consumption (up to 26%) were recorded. Therefore, waste olive oil methyl ester can be effectively used as a diesel fuel substitute.

Encinar *et al.* (2005) used a mixture of frying olive oil and sunflower oil for the production of methyl esters that can be used as biodiesel. The transesterification process was carried out in a spherical reactor at 25–65°C. When the reactor reached 65°C, methanol and catalysts (sodium hydroxide, potassium hydroxide, sodium methoxide and potassium methoxide) were added. At the end of process, two layers were formed: the upper containing methyl esters, which were further purified; and the lower phase with glycerol, excess methanol and remaining catalyst, together with the soaps formed during the reaction and some entrained methyl esters and partial glycerides. The main methyl esters produced were linoleate (40%), oleate (35%), palmitate (9%) and stearate (5%). The biodiesel endowed with the best properties was obtained using a methanol/oil molar ratio of 6:1, potassium hydroxide as catalyst at 1% (wt) concentration, and temperature 65°C.

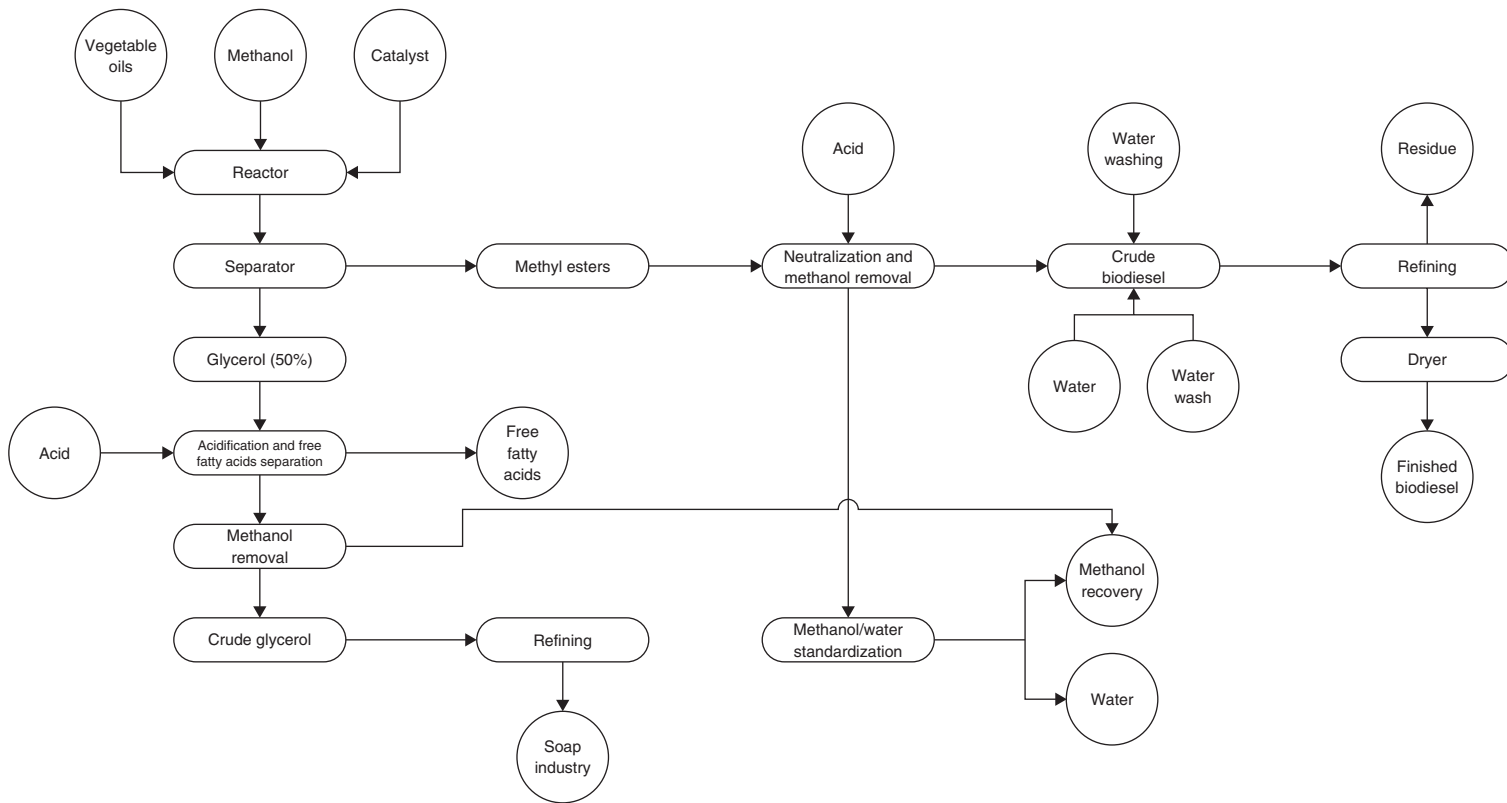

Figure 8.33 Process flow diagram for biodiesel production (adapted from Barnwal and Sharma, 2005; <http://www.uidaho.edu/bioenergy/biodieseLED/publication/01.pdf>; http://www.dft.gov.uk/stellent/groups/dft_roads/documents/graphic/dft_roads_024054-2.jpg; Arvanitoyannis and Kassaveti, 2007)

Furthermore, a two-stage transesterification imparted better properties to the final product than that of the single-stage transesterification. The produced biodiesel had similar properties (density, viscosity, cetane index, but higher heating value) to those of heavy fuel diesel No. 2, thus resulting in its use in compression ignition motors.

Among liquid biofuels, biodiesel derived from vegetable oils is gaining ground and market share as diesel fuel in Europe and the USA. The direct use of oil derived from olive kernel as a fuel for diesel engines caused serious problems, due to the high fuel viscosity in compression ignition. Dilution, micro-emulsification, pyrolysis and transesterification are the four main techniques applied towards resolving the problems encountered with high fuel viscosity (Ziejewski *et al.*, 1986). Pyrolysis produced more biogasoline than biodiesel fuel, while soap pyrolysis products can be used as an alternative diesel engine fuel. The most important variables affecting the ester yield during the transesterification reaction were the molar ratio of alcohol to vegetable oil, reaction temperature, reaction time, water content and catalyst (Demirbas, 2003).

Wastewater treatment

The removal of toxic metals from wastewaters is an issue of great interest in the field of water pollution, which is one of the most crucial worldwide environmental problems (Veglio *et al.*, 2003). One of the most widely used adsorbents is activated carbon (Niaounakis and Halvadakis, 2006) (Figure 8.34).

Cimino *et al.* (2005) examined the sorption properties of activated carbon made from olive cake and commercial activated carbons to remove aquatic pollutants such as heavy metal (HM), phenol (Ph), dodecylbenzenesulfonic acid-sodium salt detergent (DBSNa) and methylene blue dye (MB). The olive cake was dried for 2h at 105°C in an air oven, then placed in a muffle furnace with increasing temperature up to 700°C and the produced activated carbon was treated with H₂SO₄, HCl and HNO₃. Olive cake carbon showed a good sorption capacity to Ph and HM (Ag⁺, Cd²⁺, Cr³⁺) comparable to that of commercial activated carbon. Olive cake carbon displayed a slightly lower effectiveness towards removal of MB and DBSNa compounds than that observed for commercial activated carbon.

The potential use of solid olive mill residues as copper biosorbing material was investigated by Veglio *et al.* (2003). After having been dried in an atmospheric environment for a year, this waste was ground and sieved. The solid olive mill residues were found to be an appealing 'low cost' bioabsorbing material and promising copper sorbents that can be effectively used for the treatment of metal-bearing effluents.

The solid residue from olive mill waste was kiln roasted in a rotating cylinder at 150°C and then sieved into different sizes. The produced activated carbon with particle size 0.5–1.0 mm was used in batch experiments and the absorbance of methylene blue (cationic dye) and methyl orange (anionic dye) was determined. Activated carbon effectively removed methylene blue, whereas it showed poor removal of methyl orange in comparison to commercial type activated carbon capable of removing both dyes. It was concluded that the activated carbon produced by solid residue from olive mill waste is an inexpensive and effective material in removing cationic dyes, but ineffective for anionic dyes (Abu-El-Shar *et al.*, 1999).

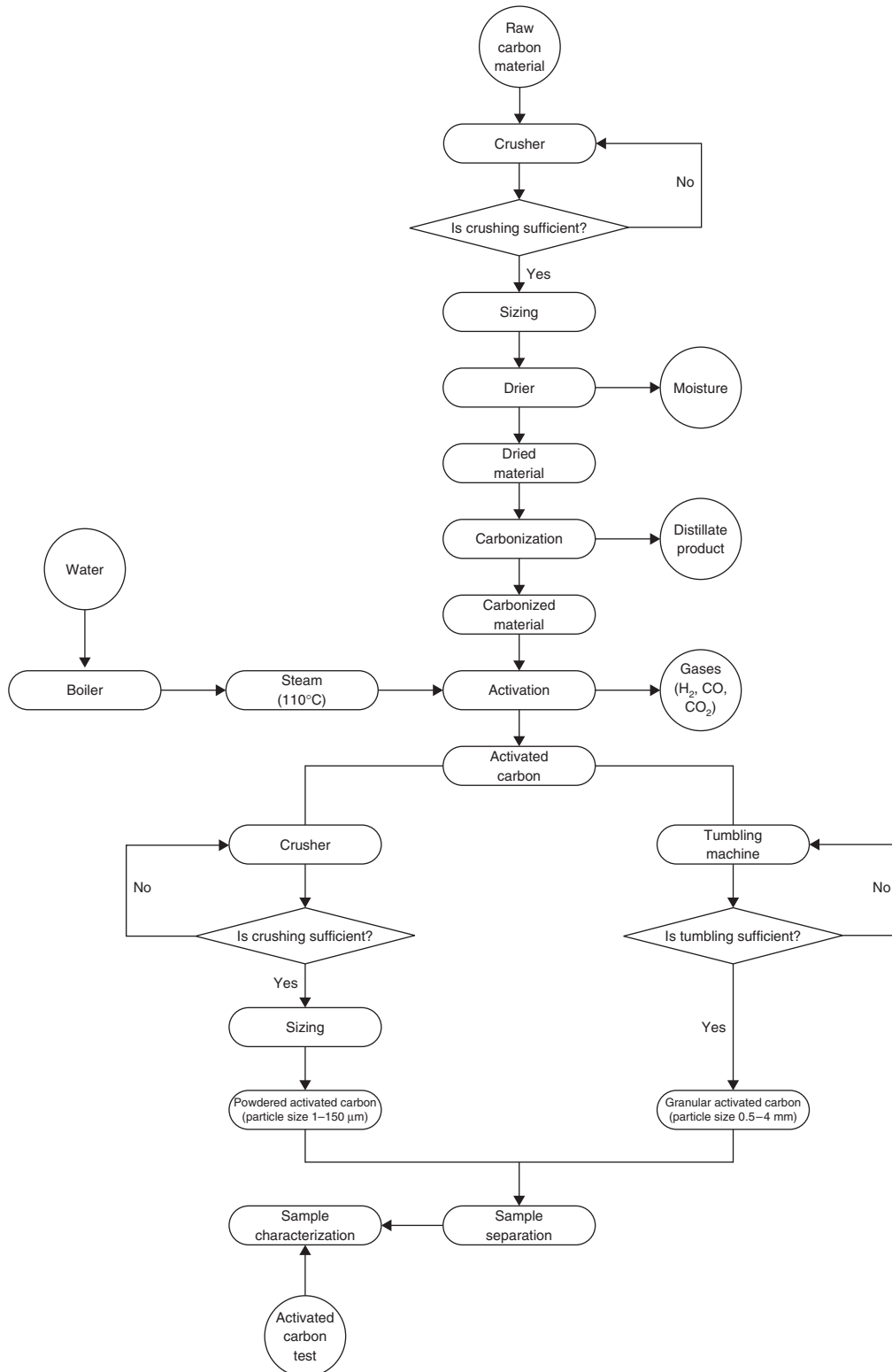

Figure 8.34 Activated carbon production (adapted from <http://www.home.att.net/~africantech/GhIE/ActCarbon.htm>; <http://www.norit.com/activatedcarbon.asp?submenuCat=introduction>; http://www.scielo.br/scielo.php?pid=S0104-66322005000100005&script=sci_arttext&lng=en; Arvanitoyannis and Kassaveti, 2006a)

Gharaibeh *et al.* (1998) examined the ability of activated carbon, made from solid residue of olive mill products, to remove ammonia (NH_3), total organic carbon (TOC) and some organic compounds, comprising heteroatoms like sulfur and halogens from a wastewater treatment plant. Batch reactors were filled with wastewater and activated carbon and the materials were mixed for 20 h. Batch experiments were also conducted in parallel using commercial types of activated carbon made from metallurgical grade coals and peat. The percentage removal of compounds from the three different types of activated carbon (peat, metallurgical grade coals and solid residue of olive mill industries) is shown in Table 8.7. The latter activated carbon can be used for tertiary treatment, or mixed with influent wastewater after screening, sedimentation etc. in the primary treatment, or fed to the aeration tank in the secondary treatment.

Galiatsatou *et al.* (2002) produced activated carbon from solvent extracted olive pulp in an attempt to examine its porosity development and its ability to remove zinc from aqueous solutions. The raw material was carbonized with nitrogen at 850°C for 1 h and 30 min and then activated with steam/nitrogen mixture at 800°C for 40 min. The obtained activated carbon displayed low oxygen content and efficient macroporous volume, resulting in a higher adsorption capacity that can be effectively employed towards aqueous zinc species removal.

El-Sheikh and coworkers (2004) used olive stones for the production of activated carbon. The sample was crushed, dried at 120°C and carbonized in a horizontal tube furnace with the temperature ranging from 25°C to 850°C under a constant flowing nitrogen atmosphere. Activation was then carried out at the same temperature and the end products were dried at 120°C for 4 h. The final products displayed high adsorptive capacity in the presence of an aqueous medium.

Lysimeter and field experiments of OMW were conducted using two calcareous soils by Cabrera *et al.* (1996). In lysimeter experiments, the soils were placed in containers and treated with two different doses of OMW for 2 or 3 years. In field experiments, the soil was irrigated with OMW for 3 years. Germination and seedling performance tests of ryegrass (*Lolium multiflorum* Lam cv. Barwoltra) were also performed in an OMW treated soil. In lysimeter experiments, a substantial removal of the organic and inorganic components occurred when OMW was applied in doses of $5000\text{--}10\,000\text{ m}^3/\text{ha}/\text{year}$ in a 2 m layer of soil. In field experiments, an increase in soil fertility in the upper layer (0–50 cm) and leaching of Na^+ and NO^{-3} below 1 m soil layer was observed. Application of OMW affected neither the germination nor the seedling emergence of ryegrass. Soils proved capable of removing the pollutants from OMW, while the recorded increase in soil fertility confirmed the agricultural use of OMW in soil.

The potential removal of Cr(III), Cu and Zn by polymerin and its derivatives, K-polymerin and $\text{Fe}(\text{OH})_x$ -polymerin complex, was investigated by Capasso *et al.* (2004). Polymerin and its derivatives were obtained from OMW produced by means of a pressure processing system. Cr(III), Cu and Zn were individually sorbed by polymerin and K-polymerin in the following order: $\text{Cr}(\text{III}) > \text{Cu} > \text{Zn}$, although sorptions of the three metals on K-polymerin were higher than those on polymerin. The individual sorption of the above metals on $\text{Fe}(\text{OH})_x$ -polymerin was much lower than the corresponding on polymerin. Although, the sorption of Cr(III) on polymerin was not affected by the presence of Zn and Cu, the presence of Zn and/or Cr(III) heavily

Table 8.7 Percentage removal of compounds from the three different types of activated carbon (peat, metallurgical grade coals, solid residue of olive mill industries)

Type of activated carbon	Percentage removal	Compounds
Activated carbon made from peat	100	Benzothiazole, 1,2-dihydro-2,2,4-trimethylquinoline, <i>N</i> -dimorpholinyl ketone, methylsulfyl benzothiazole, methyl-2-benzothiazole sulfone
	94	TOC
	82	NH ₃
	50	Tetrachloroethane
Metallurgical grade coals activated carbon	100	Benzothiazole, 1,2-dihydro-2,2,4-trimethylquinoline, <i>N</i> -dimorpholinyl ketone, methylsulfyl benzothiazole, methyl-2-benzothiazole sulfone
	87	NH ₃
	40	TOC
	31	Tetrachloroethane
Activated carbon made from solid residue of olive mill industries	100	Benzothiazole, methylsulfyl benzothiazole, methyl-2-benzothiazole sulfone
	78	NH ₃
	70	1,2-dihydro-2,2,4-trimethylquinoline
	58	Tetrachloroethane
	50	<i>N</i> -dimorpholinyl ketone
	37	TOC

Adapted from Gharaibeh *et al.*, 1998

reduced the Cu sorption. The presence of Cu and Cr(III) inhibited strongly the Zn sorption on polymerin. The results showed that polymerin did not only decontaminate the waters of heavy metals, but also enriched them in nutrients (Ca, Mg and K), released from polymerin during the remediation process.

Food industry/cosmetics

One of the major environmental problems caused by the agro-food industry in the Mediterranean area is the treatment of the olive mill wastewaters. These are the main by-products of olive oil production and are characterized by high concentrations of several organic compounds, such as organic acids, sugars, tannins, pectins, polyphenolic substances, that make them difficult to treat (Rozzi and Malpei, 1996; Gavala *et al.*, 1996; Ergüder *et al.*, 2000).

Lopez *et al.* (2000) tested four *Xanthomonas campestris* strains (NRRL B-1459, NRRL B-1459 S4L-II, DMS 1706 and T646) for their ability to grow on OMW and produce xanthan. The OMW, obtained from horizontal centrifuges for oil extraction, was filtered and then amended by blending with YM broth (0.3% yeast extract, 0.3% malt extract, 0.5% peptone, and 1.0% glucose) (<http://www.teknova.com/liquidcul-main.html?liquid/bacterial-liq/YT-broths/ytb1.htm>) or diluted with distilled water. The bacterium strains were cultured on agar YM-OMW and agar-OMW with OMW concentrations of 10–100%. The most suitable strain for xanthan production from 50–60% OMW concentration as the sole nutrient source was NRRL B-1459 S4-LII.

High OMW concentrations caused *X. campestris* growth inhibition, but it heavily depended on the strain, as even closely related strains may differ.

The potential use of OMW as a substrate for the growth of the bacterium *Xanthomonas campestris* and the production of xanthan, an extracellular polysaccharide, was investigated by Lopez and Ramos-Cormazana (1996). The OMW was diluted with tap water at different concentrations (10–90%) and NaCl 0.9% (w/v), carbon, nitrogen, salts and nitrogen and salts (together) were added to the medium at selected concentrations. Cultures of *X. campestris* (strain NRRL B-1459 S4-LII) were then inoculated to OMW as a sole source of nutrients. When only OMW was used as a medium, in the absence of other nutrients, at low concentrations growth of the bacterium was observed, while at 30–40% concentration of OMW the yield of this biopolymer was optimum (4.4 g/l). Addition of nitrogen/salts to OMW resulted in increase of xanthan yield up to 7.7 g/l. However, the color of the obtained polysaccharide was black, a major drawback for further applications. This biopolymer is widely used in food, cosmetics, pharmaceuticals, paper, paint, textiles, adhesives and tertiary oil recovery (Sutherland, 1990).

Ramos-Cormezana and coworkers (1996) investigated the enzymatic biotransformation of phenols in alpechin, a liquid waste from the three-phase decanters and presses, by using the bacterium *Bacillus pumilus* 123 as a phenol-oxidizer. Alpechin was first filtered and two groups of dilutions were prepared (20, 40, 60, 80 and 100% undiluted); the first was used as a control and the second was inoculated with *B. pumilus*. After 5 days of inoculation at 28°C and 150 rpm, the phenols were extracted by using diethyl ether and determined with high performance liquid chromatography (HPLC). At 40–100% concentrations of alpechin, *Bacillus pumilus* was effective in reducing the phenols up to 50%, while at 80% concentrations of this waste, a slight reduction of the phenol content and generation of new phenols were observed. The extracted polyphenols can be utilized in agriculture, food protection and cosmetics production because of their well known antioxidant properties.

Liquid/solid olive oil by-products from a two-phase decanter were enzymatically treated by using culture broths of *Aspergillus niger* (BRFM422) enriched in cinnamoyl esterases (polysaccharide-degrading enzymes), in order to release simple phenolic compounds, and especially hydroxytyrosol. These by-products were homogenized with ethanol and the final ethanolic extract was rich in phenolic compounds. Significant amounts of hydroxytyrosol were released, which were purified up to 85% using a two-step chromatographic treatment. However, other phenolic acids, such as caffeic, *p*-coumaric and ferulic acids, were also released but to a lesser extent. Hydroxytyrosol combines strong antioxidant action with good solubility in oily and aqueous media, thus making it useful for application in multicomponent foods (Bouzid *et al.*, 2005).

Gonzalez-Lopez *et al.* (1996) examined the ability of *Azotobacter chroococcum* strain H23 to produce homo- and copolymers of polyhydroxyalkanoates (PHAs) growing in culture media amended with alpechin, a liquid waste from the three-phase decanters and presses. An NH_4^+ -medium and a nitrogen-free culture medium supplemented with alpechin were tested for *A. chroococcum* growth and the production of PHAs. This bacterium did not grow on nitrogen-free medium, whereas the NH_4^+ -medium supported the growth of *A. chroococcum* and the production of PHAs up to 50% of the cell dry weight after 24 h. The obtained PHAs can be effectively utilized for the manufacture of plastic goods, thus considerably lowering the cost of biodegradable plastic materials.

Aissam *et al.* (2005) used OMW as a substrate for the growth of *Aspergillus niger* and tannase production. *Aspergillus niger* (strain HA37), isolated from OMW, was incubated on a synthetic medium containing tannic acid and on diluted OMW on a rotary shaker at 30°C. On the medium containing tannic acid, tannase production was 0.6, 0.9 and 1.5 EU/ml at 0.2%, 0.5% and 1% initial tannic acid concentration, respectively. On the other hand, phenols degradation in the OMW varied from 0.9 to 0.26 g/l, COD reduction was up to 71% and tannase production was around to 0.55–0.65 EU/ml. The released tannase could be utilized as an inhibitor of foam in tea production, clarifying agent in beer and fruit juices production, in the pharmaceutical industry and for the treatment of tannery effluents.

The antioxidizing potency of phenol compounds in OMW was investigated by Ranalli *et al.* (2003). Refined purified olive oil was widely utilized as an oxidation lipid substrate. Several synthetic antioxidants, like 2,3-tert-butyl-4-hydroxyanisole (BHA), 3,5-di-tert-butyl-4-hydroxytoluene (BHT), L-ascorbic acid and gallates, among others, were employed as reference compounds. The antioxidant potencies of the individual phenol compounds present in OMW can be classified into four categories as shown in Table 8.8. Mixtures of individual standards mixed with either L-proline, chlorophyll- α , chlorophyll- β , tocopherols, or a blend of chlorophylls and tocopherols were tested for their antioxidizing potency. Many phenols present in OMW displayed antioxidizing action higher than that of the less safe synthetic antioxidants and could either replace them or be used in combination with synthetic antioxidants for food preservation purposes.

Alpechin was used as a medium for the production of homopolymers containing hydroxybutyrate (PHB) and copolymers containing β -hydroxyvalerate (P[HB-co-HV]) with the bacterium *Azotobacter chroococcum* strain H23. Copolymer formation was observed only when valerate (pentanoate) was added, as a precursor, to alpechin, whereas addition of propionate did not lead to the same result. Polyhydroxyalkanoates (PHA) production reached up to 80% when the bacterium grew on NH_4^+ -media supplemented with 60% alpechin. Polyesters such as PHB and PHAs are effectively utilized as starting materials for the manufacture of plastic goods. However, the high cost of biodegradable

Table 8.8 Antioxidant activity of the phenolic compounds present in OMW

Antioxidizing activity	Phenols
High	Hydroxytyrosol, gallic acid, caffeic acid, homoprotocatechuic acid, homogentisic acid, catechin hydrate, pyrogallol, epicatechin, quercetin, sinapinic acid, protocatechuic acid, ellagic acid, α -tocopherol, γ -tocopherol
Medium	α -tocopherol, chlorogenic acid, oleuropein, lutein, 4-methylcatechol, BHA
Weak	HMCA, homovanillic acid, syringic acid, catechol, BHT, BMP, BC
None	<i>p</i> -coumaric, <i>o</i> -coumaric, quinic, shikimic, dimethoxybenzoic, 2-methoxycinnamic acids, rutin hydrate, apigenin, apigenin-7-glucoside, luteolin-7-glucoside, 2-(4-hydroxyphenyl)ethanol (tyrosol), cyanohydrin chloride, ursolic, oleanolic acids

Adapted from Ranalli *et al.*, 2003

plastics production compared to the currently available 'recalcitrant' polymers (PE, PP) is still a discouraging factor (Poza *et al.*, 2002).

Ethyl acetate extracts of OMW were evaporated under vacuum at 40°C in a rotary evaporator and the residue was re-dissolved and analyzed with HPLC. Hydroxytyrosol and tyrosol were the major compounds detected, *para*-hydroxyphenyl acetic acid, caffeic acid, *p*-coumaric acid, 3,4-dihydroxyphenylacetic acid and ferulic acid were also monitored but at lower concentrations, while protocatechuic acid, vanillic acid, synergic acids and other compounds were not recorded at quantifiable levels. The antioxidant activity of hydroxytyrosol, 3,4-dihydroxyphenyl acetic acid and caffeic acid was higher than those of antioxidants widely used in many foods, such as butylated hydroxyanisole (BHA) and butylated hydroxytoluene (BHT). The organic extract of OMW and a blend of phenolic compounds were also added to refined olive and husk oils. The results showed a considerable slowing down in the oxidation rate of oils by 3,4-dihydroxyphenylacetic acid and hydroxytyrosol superior to that of BHT, thus suggesting the potential use of these natural antioxidants for the stabilization of edible oils and the replacement of synthetic antioxidants in food (Fki *et al.*, 2005).

A standard method was used for the recovery of oil from OMW. However, since the estimation of oil from OMW with the standard method was not feasible, some modifications were made. According to the standard method OMW was treated with lime, acidified with HCl, filtered through muslin cloth (diatomaceous-silica suspension was passed through the filter before the OMW sample) and, finally, extracted with petroleum ether. The results indicated that the oil recovery ranged from 70.6% to 96.4% when the OMW was lime treated and then air passed through the mixture, filtered using muslin cloth, dried and extracted with petroleum ether. Since the recovered oil is not pure, it can be used in the soap industry (Saglic *et al.*, 2002).

Animal feed

Treated OMW may find applications as a raw material in various biotechnological processes or as animal food (Hamdi, 1993). The appropriate utilization of by-products in animal nutrition can improve the economy and the efficiency of agricultural, industrial and animal production. Furthermore, it has social and environmental benefits, especially important in the rather fragile and/or unstable Mediterranean semi-arid ecosystems where available pastures and forages are scarce (Alcaide and Nefzaou, 1996).

Olive pomace, a wet solid waste from the three-phase decanters and presses, was delignified by using *Phanerochaete chrysosporium*, *Oxysporus* spp., *Schizophyllum commune*, *Hyphoderma* spp. and *Ganoderma* spp., the last four were isolated from decaying wood. The olive pomace was alkali-treated, transferred to culture flasks and inoculated with the above fungi. After inoculation, the fermentation process was carried out at 25°C for 60 days. The results indicated that *Oxysporus* spp. degraded lignin up to 69%, whereas *Phanerochaete chrysosporium* and *Schizophyllum commune* delignified olive pomace 60% and 53%, respectively. However, the potential use of treated olive pomace as a feed for poultry is still under investigation (Haddadin *et al.*, 2002).

Olive pomace, coming from olive oil pressing factories, was pretreated with NaOH 3%, delignified by *Phanerochaete chrysosporium*, *Phlebia radiata*, *Pleurotus ostreatus*

and *Dacrymyces stellatus*, saccharified with *Trichoderma* spp. and then inoculated with *Saccharomyces cerevisiae* or *Candida utilis*. The analysis revealed a decrease in cellulose, hemicellulose and lignin, degradation of lignified materials, sugar reduction and production of crude protein up to 40.3%. The fermented olive pomace can be used as a feed for the poultry industry (Haddadin *et al.*, 1999).

Alcaide and Nefzaou (1996) utilized olive oil by-products, such as leaves and twigs, wastewater and solid residue (olive cake and pulp) in animal nutrition. Ruminants are probably the most efficient herbivores in terms of their utilization of materials rich in cell walls, as is the case of by-products. The nutritional evaluation of the above olive oil industry wastes was determined by using chemical, physicochemical, biological and indirect methods. The by-products should be characterized in terms of their chemical and nutrient composition and compounds like phenols should be quantitatively determined. The use of such wastes as nutrient sources for animals may also further enhance the efficiency of vegetal, industrial and animal production and, consequently, their respective profitabilities.

Other uses

Fernandez-Bolanos *et al.* (2002) pretreated alperujo, a wet solid waste from the three-phase decanters and presses, by adding acid (H_2SO_4) and alkaline (NaOH) catalysts to this waste and fed it into a flash hydrolysis laboratory pilot unit, where it was treated by steam in order to produce highly purified hydroxytyrosol. The addition of acidic catalyst to alperujo facilitated the release of hydroxytyrosol, in comparison to alkaline catalyst. Out of 1000 kg of alperujo (70% humidity), 4.5–5 kg of hydroxytyrosol were produced and, after the purification process, using a new chromatographic system, 3 kg of hydroxytyrosol (90–95% purity) were obtained. Hydroxytyrosol displayed strong antioxidant properties in accelerated oxidation conditions.

Hytiris *et al.* (2004) blended two olive mill sludge (OMS) samples, of various moisture contents, with cement containing a special additive, consisting of artificial and natural zeolites and lime at specific proportions, without any addition of aggregates in order to examine the potential use of OMS in the solidification process. The first sample with the lowest moisture content displayed a higher percentage of dry matter than the second sample. The final product of the sample with the lowest moisture was solid, had compressive strength 1 MPa and an elastic modulus of 50 MPa and was employed as a construction material for the enlargement of parking areas, roads, water purification plants, foundations etc. In contrast, the final material of the sample with the highest moisture level behaved like a 'slurry' and could be effectively used in landfilling, or as a drainage material instead of natural gravel.

Boz and coworkers (2003) investigated the herbicidal effect of olive processing waste (OPW) on some weed species in wheat, maize and sunflower. OPW is a liquid waste released to the environment after olive processing or collected in pools and a solid waste is formed (solid OPW) via evaporation. Solid OPW (two doses 3 and 4.5 kg/m) was blended with soil and seeds of sunflower and maize were sown for the evaluation of the germination rates and the growth of maize, sunflower and the weed *Portulaca oleracea* L. (common purslane). On the other hand, liquid and solid OPW

(4.5 and 6 kg/m for the solid form and 5 and 10 kg/m for the liquid form, respectively) mixed with soil and seeds of wheat were sown and the germination rates and growth of wheat and weeds were monitored. OPW decreased the germination rates of both maize (26% at 4.5 kg/m) and sunflower (12% at 3 kg/m and 18% at 4.5 kg/m). Moreover, OPW caused height reduction in maize plants initially, but they finally recovered, and stimulated sunflower growth. A significant reduction in *Portulaca oleracea* plants was reported ranging from 63 to 76% at 3 and 4.5 kg/m, respectively. Furthermore, both forms of OPW caused a decrease in height and in germination rates of wheat; 37% and 58% at 4.5 and 6 kg/m for the solid form, respectively; and 19% and 30% at 5 and 10 kg/m for the liquid form, respectively. Weeds, such as *Capsella bursa-pastoris* (L.) Medic., *Matricaria chamomilla* L. and *Lamium amplexicaule* L. displayed a higher sensitivity to OPW applications than *Stellaria media* (L.) Vill. and *Poa annua* L. OPW can be utilized as an alternative to chemical weed control in sunflower, maize and wheat.

Polar extracts of olive oil and OMW samples were examined for their antioxidant activity by Papadimitriou *et al.* (2005). The olive oil extract was rich in phenolic compounds (especially caffeic acid), whereas the OMW extract was rich in tannin. The electron paramagnetic resonance (EPR) in combination with the spin trapping technique and the photometric procedure based on the formation of the N-N-dimethyl-p-phenylenediamine colored radical cations were the methods used for the evaluation of the antioxidant activity of the olive oil and OMW extracts. The OMW extract was shown to be more potent in scavenging free radicals than olive oil extracts.

A number of methods, such as hydrolysis, boiling, ultrasound, addition of enzymes, fermentation and boiling and addition of enzymes were suggested for the pretreatment of olive cake. The olive cake was then incubated with *Ceratocystis moniliformis* and *Pityrosporum ovale* and the samples were kept at optimum temperature (30°C for *C. moniliformis*; 37°C for *P. ovale*), pH (5.0 for *C. moniliformis*; 6.4 for *P. ovale*) and humidity (50% for *C. moniliformis* and *P. ovale*) conditions. A simultaneous steam distillation-extraction method was run for the concentration of the aroma of the fermented olive press cake and the liquid aroma samples were analyzed with gas chromatography (GC). The polyphenolic fraction of the olive cake inhibited the microorganisms' growth and the pretreatment methods led to oil losses and minor lactone synthesis (Laufenberg *et al.*, 2004).

Alfano *et al.* (2006) examined the potential of water and energy savings in olive mill plants by OMW re-use. Fresh olives were crushed and thermo-mixed for 35–40 min at 27°C, while olive oil extraction was performed through partial OMW recycling ranging from 0% to 57%. Olive oil produced with OMW partial recycling did not show any increase of polyphenol content, due to the higher affinity of total polyphenols to the aqueous phase. Process stability and extraction yields did not display significant changes, whereas at 57% OMW recycling, a slight reduction of oil extraction yield was reported. Partial recycling of OMW can be an advantageous solution for water and energy saving in a continuous olive oil mill plant due to:

- 1 less water consumption and consequent reduction of water supplying and depuration costs
- 2 energy saving (2–5 kW/h when water heating up to 27°C)
- 3 reduction of OMW volume

- 4 less disposal costs
- 5 less agricultural surfaces for OMW spreading.

Table 8.9 provides a synoptical presentation of olive oil waste treatment methods, applied substrates, physicochemical characteristics and final product applications/uses.

Disadvantages of several olive oil waste treatment methods

Piotrowska *et al.* (2006) examined the short-term effects of OMW on chemical and biochemical properties of a sandy clay loam soil. The OMW coming from a conventional, three-phase extraction plant was centrifuged and stored at -20°C . The soil was put in plastic pots and treated with OMW at different doses (0, 40, 80 m^3/ha field doses, respectively) and then incubated in a climatic chamber at 25°C , in the dark, for 14, 28 and 42 days. Increases in total organic carbon (TOC), extractable N and C, available K, Mn and Fe, soil respiration, dehydrogenase and urease activities and microbial biomass were monitored. However, pH, Ca and Mg contents and phosphatase, β -glucosidase, nitrate reductase and diphenol oxidase activities decreased considerably. From tomato seed germination tests, the use of OMW for soil fertigation should be avoided, due to heavily increased ($>80\%$) soil phytotoxicity (large decline of soil germination capability) after the addition of the higher dose 80 m^3/ha of OMW.

Toscano and coworkers (2003) examined the potential use of phenol oxidase activity of green olive drupae for the dephenolization of polluted waters. It was shown that raw extracts and acetone powders consisting of treating olive tissues with cold acetone (-20°C) for oil, polyphenols and chlorophyll removal, were effectively used for enzyme extraction. Although olive husk was also used as a cheap enzyme source, no enzyme extraction was possible with the method described above. Olive drupae tissues displayed a relevant phenol oxidase activity with high specificity towards *o*-diphenols and *p*-methyl-substituted phenols. Phenol oxidase extraction from plant tissues is really difficult even with the aid of detergents. The main drawbacks for a widespread application of this environmental methodology are the high cost of enzyme extraction and purification in conjunction with the low operational stability observed.

Fresh OMW from a three-phase discontinuous extraction plant was pretreated with the white-rot fungus *Phanerochaete chrysosporium* DSMZ 6909 and, after a decantation step, it was anaerobically digested (Sayadi and Ellouz, 1995). Untreated OMW was applied to a field with olive trees at the following doses: 50, 100 and 200 m^3/ha (Ben Rouina, 1994), while treated OMW was applied at a dose of 400 m^3/ha . Untreated effluent of OMW was quite acidic, increased soil salinity and appeared to be toxic from 100 m^3/ha , attributed to the high phenolic content. At 200 m^3/ha , the toxic effects were much more pronounced as total mesophilic, yeasts and molds, actinomycetes and nitrifiers were inhibited, except for total coliforms and spore-forming bacteria. On the other hand, treated effluents of OMW contained N, P, K and heavy metals at low concentrations, were pathogens-free, relatively non-toxic and, thanks to their excellent quality, can be effectively used for irrigation after field tests. However,

Table 8.9 Olive mill waste treatment methods, physicochemical characteristics, substrate to be applied and final product/uses

No	Substrate to be applied	Treatment method	Physicochemical characteristics	Final product/Uses	References
<i>A. Fertilizer/amendment</i>					
1	Olive marc	Aerobic composting process	Limited nematodical activity	Compost amendment with dry-olive marc and dry-rice husk (1:1)	Nico <i>et al.</i> , 2004
2	OMW (65%) and olive leaves (35%)	Composting	TN = 17.6, P = 1.5, K = 12.6, Ca = 127.5, Mg = 6.8, Na = 1.1, Fe = 9.1 (Units: g/kg)	Mixture of compost with sphagnum peat or commercial substrate (CS) for ornamental plants growth	Garcia-Gomez <i>et al.</i> , 2002a
3	Olive husk	Composting (aeration of piles by mechanical turning or forced air-injection)	Active microbial community, OM degradation	Bio-fertilizer	Baeta-Hall <i>et al.</i> , 2005
4	OMW	Addition of elemental sulfur during composting (windrows)	Reduction in pH by 1.1 unit (addition 0.5% sulfur and moisture of compost 40%) and no phytotoxic effect	Soil amendment	Roig <i>et al.</i> , 2004
5	OMW	Composting of mixture (OMW, sewage sludge, cotton gin waste) using the Rutgers static pile system (15 days, 55°C)	Low organic matter and nitrate contents, higher EC, stabilized and humified organic matter, low toxicity	Soil fertilizer (not in high rates)	Paredes <i>et al.</i> , 2004
6	Olive-tree leaves (90%) and olive pomace (60%)	Windrow composting	Increase in soil organic matter content, P and K availability, increase in rhizosphere temperature by 10–15°C, no phytotoxicity	Soil amendment in organic greenhouse production of cucumber (<i>Cucumis sativus</i>)	Ehaliotis <i>et al.</i> , 2005
7	Olive cake	Vermicomposting for 9 months (alone or mixed with biosolids)	Extraction of humic substances and three hydrolytic enzymes (β -glucosidase, phosphatase and urease)	Soil amendment for reactivation of C, P and N-cycles in degraded soils (for regeneration purposes)	Benitez <i>et al.</i> , 2005
8	Alperujo (solid material)	Co-composting of alperujo and cotton waste (forced aeration, 50°C, moisture 45–55%)	Compost free of toxicity, rich in organic matter (mainly composed of lignin), high content in potassium and organic nitrogen but low in phosphorus and micronutrients	Organic amendment for the production of pepper (<i>Capsicum annuum</i> cv 'Orlando')	Albuquerque <i>et al.</i> , 2005
9	Olive cake and olive leaves	Composting for 3 months	pH = 7.58, EC = 8.49 S/ in 1:2 volume water extracts	Growing medium component for production of <i>Euphorbia pulcherrima</i> (poinsettia) (25 compost:75 peat:100 perlite)	Papafotiou <i>et al.</i> , 2004
10	Extracted olive press cake	Windrows composting	High content of lignin (20%), dark appearance (black), sufficient amount of nutrients, good physicochemical characteristics	Persistent in soils and substrates, humus formation	Manios, 2004

11	Olive tree leaves	Turned windrow composting for 8 weeks	Accumulation of NO ₃ -N, high EC (3.7 S/cm), pH = 7.5, large amount of humic substances, phytotoxic when used in large amounts (more than 30% by volume)	Effective bulking agent when mixed with high moisture content materials (pig manure and sewage sludge)	Manios, 2004
12	Olive tree branches	Windrows composting	Low organic matter, high EC (9.8 mS/cm)	Effective bulking agent mixed with cucumber plant biomass	Manios, 2004
13	Solid residue and OMW	Composting of solid wastes and wastewaters (23 days, 45–65°C, C/N 30/1, moisture 40–60%) followed by stabilization	Organic matter content Energy production 376 812 000 kJ	1 Soil-conditioner (improvement of soil ion-exchange capacity and porosity) 2 Fuel	Vlyssides <i>et al.</i> , 1996
14	Solid fraction of OMW and olive leaves	Composting of mixture A: solid fraction of OMW (65%) + olive leaves (35%) and mixture B: solid fraction of OMW (74%) + olive leaves (25%) + 1% urea in trapezoidal piles according to Rutgers static composting system (moisture 40–60%, 55°C, ventilation 30 s/15 min)	1 Mixture A: biological activity and degradation organic matter (64%), lignin and cellulose (60%), fat 2 Mixture B: biological activity and degradation organic matter (40%), lignin and cellulose (38–39%), fat	Composts	Garcia-Gomez <i>et al.</i> , 2002b
15	Olive press cake and OMW	Composting olive press cake and OMW/tap water for 5 months with 9 moistenings (WHC 60%, temperature below 30°C)	Detoxification of the materials used in both treatments, increase of pH and conductivity in the olive cake + OMW compost	Fertilizer	Mari <i>et al.</i> , 2003
16	Olive pomace and OWW (treated and untreated)	1 Composting of olive pomace, poultry manure and wheat straw in an open field (moisture 50–60%, temperature 50–60°C for 40 days and 35–45°C for 150 days) 2 Treated OMW with mineral catalyst	-	Soil amendment for rye grass	Montemurro <i>et al.</i> , 2004
17	OMW	Composting mixtures of 0.9 l OMW/kg + 33% sewage sludge + 67% cotton gin and 2.1 l	Both composts: higher OM and N _{org} than the limits set by Spanish legislation for compost, lack of phytotoxicity, stabilized and humified OM, high EC,	Applied to soil	Paredes <i>et al.</i> , 2001

(Continued)

Table 8.9 (Continued)

No	Substrate to be applied	Treatment method	Physicochemical characteristics	Final product/Uses	References
18	OMW	OMW/kg + 22% cotton gin + 78% waste from orange juice extraction (Rutgers static pile system, 55°C, moisture 40% and 30 s ventilation every 15 min) Composting of OMW and wheat straw in a forced aerated static pile	lower nitrification, increased cation exchange capacity Compost of OMW + cotton gin + waste from orange juice waste: lower degree of maturity Presence of nutrients, mainly organically-bound nitrogen (1.553%), absence of heavy metals, good level of humification (degree of humification = 78%; humification index = 0.28), absence of phytotoxicity, stabilization of the end product	Fertilizer for maize, rye grass and horticultural plants	Tomati <i>et al.</i> , 1996
19	Olive marc and OMW	Composting of olive marc, wheat straw and OMW for a year, aerated every 15 days and homogenized	Decrease of OM and C/N, OM losses, less degradation of lignin than cellulose and hemillulose, decrease of phenol (66%) and lipids (97%), increase in N and ash content	Fertilizer or amendment	Baddi <i>et al.</i> , 2004
20	Solid wastes	Burning at 550°C	Reduces plasticity, 2.5% of burned olive waste increases maximum dry density and unconfined compressive strength while in higher percentages it decreases both, 7.5% of olive ash minimizes the swelling pressure	Soil stabilizer	Attom and Al-Sharif, 1998
21	OMW	Mixed with rock phosphate and fermented in batch and repeated-batch experiments in air-lift reactor fed with <i>Aspergillus niger</i> spores at 30°C for 8 days	1 Batch experiments: COD reduction (35%), negligible total phenols reduction, total sugars reduction (60%) 2 Repeated-batch experiments: COD reduction (64%), removal of total sugars (59%) and phenols (10%)	Fertilizer (OMW derived from batch experiments)	Cereti <i>et al.</i> , 2004
22	OMW (added N and Mg)	Fermentation and immobilization with fungus <i>Aspergillus niger</i> NB2	COD and total phenols reduction	Potential use in plant growth	Vassilev <i>et al.</i> , 1997
23	OMW	Repeated-batch fermentation with	Reduction in phenols (36–59%) and pH (by 1 unit)	Production of fertilizer (enriched or not with solubilized rock	Vassilev <i>et al.</i> , 1998

24	OMW	<i>Aspergillus niger</i> (strain NB2) at 30°C and at 200 rpm 1 Pretreatment with H ₂ O ₂ under alkaline conditions 2 Bioconversion by a N ₂ fixing microbial consortium (<i>Azotobacter vinelandii</i> , strain A and others) under well aerated conditions	Thick, yellow, non-phytotoxic liquid, pH 7.5–8.0, containing exopolysaccharides, major and trace plant nutrients, organic nitrogen	phosphate), improving plant growth Organic soil conditioner	Chatjipavlidis <i>et al.</i> , 1997
25	OMW	Aerobic biological treatment with <i>Azotobacter vinelandii</i> in a rotating biowheel reactor for 5 days	Increase in soil microorganisms (r-strategy)	Inhibition in growth of <i>Rhizoctonia solani</i> in soils treated with OMW (treated and bioremediated)	Kotsou <i>et al.</i> , 2004
26	OMW	Culture of <i>Azotobacter vinelandii</i> in OMW	Reduction of COD (70%) after 3 days, and phenols (100%) after 7 days, total P remained stable, N increase, sugars degradation after 3 days	Fertilizer	Piperidou <i>et al.</i> , 2000
27	OMW	Anaerobic digestion mixture of diluted OMW and piggery effluent (original or digested anaerobically) in an up-flow anaerobic filter type at 35 ± 1°C	Black color, conversion of 70–80% of the influent COD (20–60 kg COD m ³) into biogas, neutral/basic pH of the final effluent	Agricultural irrigation	Marques, 2001
28	OMW	Aerobic pretreatment of OMW using <i>Phanerochaete chrysosporium</i> DSM 6909 followed by anaerobic digestion (37°C) and ultrafiltration	Effluent free of pathogens, less toxic (26%) and low concentrations of heavy metals, methane production, concentration of N, P, K	The effluent can be used for irrigation after field tests and methane as an energy source for the needs of a small olive mill	Dhouib <i>et al.</i> , 2006
29	OMW	Centrifugation followed by filtration, concentration, methanol treatment and lyophilization for the recovery of polymerin	Carbohydrates, melanin, proteins, monosaccharides, phenols, amino acids metals (K ⁺ , Na ⁺ , Ca ²⁺ , Mg ²⁺ , Zn ²⁺ , Fe ³⁺ , Cu ²⁺), reduced COD, BOD, humic acid characteristics	Use of polymerin as bioamendments and macro- and microelement biointegrators and as a biofilter for toxic metal removal (similarities with humic acids)	Capasso <i>et al.</i> , 2002
30	OPC (olive press cake)	OPC supplemented with different dilutions of OMW (12.5%, 25% or 50%) and inoculation with <i>Pleurotus</i> strains	Density of wastewaters (more concentrated, more toxic)	Substrate for the culture of edible fungi	Zervakis <i>et al.</i> , 1996

(Continued)

Table 8.9 (Continued)

No	Substrate to be applied	Treatment method	Physicochemical characteristics	Final product/Uses	References
31	OMW	Three-phase production unit with oxidation with Fenton reagent. Detoxification of wastewaters	Organic matter	Fertilizer in olive farm	Vlyssides <i>et al.</i> , 2003
32	OMW	Centrifugation (4000 rpm, 10 min), ultrafiltration (Polysulphone flat membrane, 30°C)	Decrease in COD 90%, suspended solids and ashes 80% and low phytotoxicity	Fertilizer	Turano <i>et al.</i> , 2002
33	OMW	Mixture of wheat straw and wastewater (25–75%) followed by sterilization (45 min, 121°C) and mixed with wheat bran	Organic fraction (sugars, tannins, polyphenols, polyalcohols, pectins and lipids)	Cultivation of two <i>Pleurotus</i> species (<i>Pleurotus sajor-caju</i> and <i>P. cornucopiae</i> var. <i>citrinopileatus</i>)	Kalmis and Sargin, 2004
34	Alpechin and OMW sludge	Homogenized and stored at 4°C	Organic matter and nutrients (N, P, Ca, Mg and Fe)	Organic fertilizers in soils for the improvement of soil fertility	Paredes <i>et al.</i> , 1999
35	OMW	A mixture of sludge and soil was incubated at 25 ± 2°C	Decomposition of toxic organic compounds, increase of exchangeable potassium, reduction of soil nutrient anion levels.	Soil fertilizer	Riffaldi <i>et al.</i> , 1993
<i>B Biogas/biodiesel/hydrogen production</i>					
36	Olive pit and cuttings	Pyrolysis at 400–700°C, with heating rates 120–165°C/s, at atmospheric pressure, under nitrogen	Bio-oil, pyrolytic gas and charcoal	Charcoal briquetting Further investigation of bio-oil	Zabaniotou and Karabelas, 1999
37	Solid wastes (foot cake)	Combustion (average temperature 850 ± 10°C, combustion air temperature 23°C, flow of combustion air 570 Nm ³ /h, and relative humidity 40%)	Combustible	Substitute of No. 2 heavy fuel	Masghouni and Hassairi, 2000
38	OMW and olive husk	Gasification/combustion	Heating value	Energy production	Caputo <i>et al.</i> , 2003
39	Olive cake	Drying in oven (1 h, 105–110°C), ground in a mill (reduction particle size) and mixed with oil shale	Calorific value 31.2 kJ/g	Source of energy – fuel Catalyst to oil shale combustion	Alkhamis and Kablan, 1999

40	Olive cake	Combustion in a circulating fluidized bed (900°C-5h)	Flue gas (O ₂ , SO ₂ , CO ₂ , CO, NO _x , C _m H _n , ash)	1 Fuel in small-scale industries 2 Ash used as soil fertilizer	Topal <i>et al.</i> , 2003
41	Olive residues	Pyrolysis in a stainless steel fixed-bed reactor (400–700°C) under different atmospheres (normal, sweeping gas-N ₂ , steam)	Bio-oil production	1 Fuel 2 Added to petroleum refinery feedstocks 3 Upgraded by catalysts to produce premium grade refined fuels 4 Use as chemical feedstocks	Putun <i>et al.</i> , 2005
42	Olive cake	Co-combustion with lignite coal in a circulating fluidized bed (700°C)	Combustion efficiency 96.3–98.5%	Fuel for energy production in small-scale industries	Atımtay and Topal, 2004
43	Olive bagasse	Pyrolysis in a stainless steel tubular reactor with a sweep gas (nitrogen) at 350–550°C	Production of bio-oil (mixture of aliphatic and aromatic hydrocarbons) with low oxygen content, presence of oxygenated fractions (carboxyl and carbonyl groups) and heating value 31.8 MJ/kg	Fuel and chemical feedstock	Sensoz <i>et al.</i> , 2006
44	Olive pulp and olive stone	Carbonization in a stainless steel autoclave at 400°C for 1 h under N ₂ flow, activation in a thermolyne silica electric oven with a temperature control device linked to a thermocouple at 750–850°C for 30–70 min	High adsorption capacity, high surface area	Activated carbon production Absorption of pollutants from liquid phases (water)	Bacaoui <i>et al.</i> , 2001
45	Olive husk	Direct and catalytic (ZnCl ₂ , Na ₂ CO ₃ , K ₂ CO ₃) pyrolysis (477–752°C) in a stainless steel cylindrical reactor	Hydrogen production	Fuel for internal combustion engines in automobiles (H ₂ from direct catalytic pyrolysis)	Caglar and Demibras, 2002
46	Olive refuse and paper mill waste	Briquetting by using a hydraulic press under pressures of 150, 200 and 250 MPa	Shatter index 4813, compressive strength 319 kg/cm, water resistance time 27 min	Durable fuel briquettes production – alternative energy source	Yaman <i>et al.</i> , 2000
47	Olive seeds (solid waste)	Dried for 1 h at 100°C, separated and the seeds carbonized in a sealed crucible at 400, 600, 800°C for 1 h	Activated carbon production	Better than regenerated activated carbon, and commercial type	Walid, 2001
48	OMW	Evaporated (under vacuum or atmospheric pressure), dried at 105°C, and pyrolyzed (200–550°C)	Reduction of COD (98%), organic load in the residues (98%) and absence of polyphenols	Fuel to provide heat in the evaporation stage	Vitolo <i>et al.</i> , 1999

(Continued)

Table 8.9 (Continued)

No	Substrate to be applied	Treatment method	Physicochemical characteristics	Final product/Uses	References
49	OMW	Column-photobioreactor with <i>Rhodobacter sphaeroides</i> OU.001	Reduction of COD (35%), BOD (58%), phenol content (60%), low CO ₂	Hydrogen gas production/fuel cells Electricity production	Eroglou <i>et al.</i> , 2004
50	Olive pomace (solid residue)	Batchwise and semicontinuous anaerobic digestion at 37 ± 0.5°C	Medium calorific value	Biogas (methane) production – substitute natural gas	Tekin and Dalgic, 2000
51	Waste olive oil (from hospital kitchens)	Transesterification with methanol in presence of KOH (catalyst)	Production of olive oil methyl ester	Biodiesel fuel production	Dorado <i>et al.</i> , 2004
52	Waste vegetable oil	Transesterification	Low content of free glycerol, total glycerol 2.1%, presence of some unreacted glycerides, carbon residue	Biodiesel	Dorado <i>et al.</i> , 2003b
53	Mixture of frying olive oil and sunflower oil	Transesterification by means of methanol using sodium hydroxide, potassium hydroxide, sodium methoxide and potassium methoxide as catalysts	Properties similar to those of no. 2 diesel (density, viscosity, cetane index, but higher heating value)	Biodiesel for compression ignition motors	Encinar <i>et al.</i> , 2005
54	Olive kernel	Dilution, microemulsification, pyrolysis and transesterification	Biodiesel production	Soap pyrolysis products can be used as alternative diesel engine fuel.	Demirbas, 2003
<i>C Wastewater treatment</i>					
55	Olive cake	Carbonization (2 h, 105°C) and activation (in a muffle furnace 700°C) and acidic treatment (H ₂ SO ₄ , HCl, HNO ₃)	Sorption properties of the olive cake activated carbons	High sorption capacity to phenol and heavy metal, low sorption capability to methylene blue dye and dodecylbenzenesulfonic acid-sodium salt detergent	Cimino <i>et al.</i> , 2005
56	Solid olive mill residues	Dried, ground and sieved	'Low cost' biosorbing material, copper sorbent	Treatment of metal-bearing effluents	Veglio <i>et al.</i> , 2003
57	Solid residue from olive mill waste	Kiln roasted in a rotating cylinder at 150°C	Significant methylene-blue and poor methyl-orange removal	Treatment of water contaminated with cationic dyes (like methylene-blue), not effective in removing anionic dyes	Abu-El-Shar <i>et al.</i> , 1999
58	Solid residue from olive mill waste	Batch experiments in a reactor fed with activated carbon made from solid residue from olive mill waste	Removal of pollutants from wastewater effluent: benzothiazole, methylsulfyl benzothiazole and methyl-2-benzothiazole sulfone 100% > NH ₃	Industrial wastewater treatment (tertiary treatment, mixed with influent wastewater after screening, sedimentation etc. in the primary	Gharaibeh <i>et al.</i> , 1998

		and commercial type activated carbon	78% > 1,2-dihydro-2,2,4-trimethylquinoline 70% > tetrachloroethane 58% > N-dimorpholinyl ketone 50% > TOC 37%	treatment, fed to the aeration tank in the secondary treatment)	
59	Solvent extracted olive pulp	Carbonization under N ₂ at 850°C for 1 h 30 min and activation with steam/nitrogen mixture at 800°C for 40 min	Adsorption capacity, low oxygen content, significant number of basic groups, along with an efficient macroporous volume	Adsorbents for the removal of water pollutants and contaminants (Zn ²⁺)	Galiatsatou <i>et al.</i> , 2002
60	Olive stones	Carbonization in a horizontal tube furnace heated up to 850°C at 20°C under constant flowing N ₂ , followed by activation at the same temperature	High adsorptive capacity	Adsorbents in the presence of an aqueous medium	El-Sheikh <i>et al.</i> , 2003
61	OMW	Lysimeter and field experiments of OMW in calcareous clayey soils	1 Increased fertility 0–50 cm layer and leaching Na ⁺ , NO ₃ ⁻ below 1 m layer of soil (field experiments) 2 Reduction of organic and inorganic pollution of 2 m layer (lysimeter experiments)	Pollution removal capacity of soils and soil fertilizer	Cabrera <i>et al.</i> , 1996
62	OMW	Transformation into a complex polymeric mixture	Sorption properties of polymerin, the humic-acid-like fraction of OMW and its derivatives, K-polymerin and an Fe(OH) _x -polymerin complex	Remediation of waters contaminated with Cr(III), Cu and Zn, release of Ca, Mg, and K by polymerin	Capasso <i>et al.</i> , 2004
<i>D Food industry/cosmetics</i>					
63	OMW	Inoculation of cultures of bacterium <i>Xanthomonas campestris</i> (strain NRRL B-1459 S4-LII)	Xanthan production	Used in food, cosmetics, pharmaceuticals, paper, paint, textiles, adhesives and tertiary oil recovery	Lopez and Ramos-Cormenzana, 1996
64	Alpechin	Enzymatic biotransformation of phenols by using the bacterium <i>Bacillus pumilus</i> 123	Polyphenols extraction	Agriculture and food protection	Ramos-Cormezana <i>et al.</i> , 1996
65	Liquid/solid olive oil by-products	Enzymatic treatment using culture broths of <i>Aspergillus niger</i> (BRFM 422) enriched in cinnamoyl esterases	Antioxidant properties and satisfactory solubility in oily and aqueous media of hydroxytyrosol	Natural antioxidant and application in multicomponent foods	Bouزيد <i>et al.</i> , 2005
66	Alpechin	Culture media amended with alpechin used for the growth of <i>Azotobacter chroococcum</i> strain H23	Production of great quantities of homo- and copolymers of polyhydroxyalkanoates (PHAs)	Manufacture of bioplastics	Gonzalez-Lopez, 1996

(Continued)

Table 8.9 (Continued)

No	Substrate to be applied	Treatment method	Physicochemical characteristics	Final product/Uses	References
67	OMW	Cultivation of <i>Aspergillus niger</i> strain HA37 on diluted OMW	Tannase production, phenols degradation (71%), COD reduction (71%)	Inhibitor of foam in tea, clarifying agent in beer and fruit juices production, pharmaceutical industry, treatment of tannery effluents	Aissam <i>et al.</i> , 2005
68	OMW	Isolation of phenolic complexes	Anti-oxidant properties of phenol content	Food preservatives in combination with other natural antioxidants	Ranalli <i>et al.</i> , 2003
69	OMW	Inoculation of OMW with the bacterium <i>Azotobacter chroococcum</i> strain H23	PHB and PHAs production	Starting materials for the manufacture of plastic goods	Pozo <i>et al.</i> , 2002
70	OMW	Evaporation of organic (ethyl acetate) extract of OMW under vacuum at 40°C in rotary evaporator and extraction of phenolic compounds	Antioxidant properties of extract (hydroxytyrosol and 3,4-dihydroxyphenylacetic acid)	Natural replacement of synthetic antioxidant food additives and stabilization of oils	Fki <i>et al.</i> , 2005
71	OMW	Treated with lime, filtration, drying and extraction with an organic solvent (petroleum ether)	Oil recovery (70.6–96.4%)	Soap industry	Saglic <i>et al.</i> , 2002
<i>E Animal feed</i>					
72	Olive pomace	Alkaline pretreatment (3% NaOH) followed by delignification (<i>Phanerochaete chrysosporium</i> , <i>Phlebia radiata</i> , <i>Pleurotus ostreatus</i> , <i>Dacrymyces stellatus</i>), saccharification with <i>Trichoderma</i> spp. and inoculation with <i>Saccharomyces cerevisiae</i> or <i>Candida utilis</i>	Decrease in cellulose, hemicellulose and lignin, degradation of lignified materials, sugar reduction, production of crude protein (40.3%)	Animal feed for the poultry industry	Haddadin <i>et al.</i> , 1999
73	Olive pomace	Delignification by using <i>Phanerochaete chrysosporium</i> , <i>Oxysporus</i> spp., <i>Schizophyllum commune</i> , <i>Hyphoderma</i> spp. and <i>Ganoderma</i> spp.	Lignin degradation up to 69% by <i>Oxysporus</i> spp., 60% by <i>Phanerochaete chrysosporium</i> and 53% by <i>Schizophyllum commune</i>	Feed for poultry	Haddadin <i>et al.</i> , 2002

74	Olive oil by-products (leaves, twigs, OMW, solid residues)	Physicochemical, chemical, biological and indirect methods	Increased dry matter protein level	Animal feed	Alcaide and Nefzaou, 1996
<i>F Other uses</i>					
75	Alperujo	Steam treatment of the waste in a flash hydrolysis laboratory pilot unit with or without acidic and basic catalysts	Antioxidant properties in accelerated oxidation conditions	Hydroxytyrosol production	Fernandez-Bolanos <i>et al.</i> , 2002
76	Olive mill sludge (OMS)	Solidification of two OMS samples with different moisture content with cement and cement additive (powercem)	1 Low moisture content material: high percentage of dry matter, elastoplasticity, stiffness and strength 2 High moisture content material: slurry	Additive in construction materials (low moisture content) and drainage material/landfills (high moisture content)	Hytiris <i>et al.</i> , 2004
77	Olive processing wastes (OPW) (liquid and solid)	Mixtures of liquid OPW + soil and solid OPW + soil	Herbicidal effect on weed species	Alternative to chemical weed control methods	Boz <i>et al.</i> , 2003
78	OMW and olive oil	1 Electron paramagnetic resonance in combination with spin trapping technique 2 Photometric procedure based on the formation of the N-N-dimethyl-p-phenylenediamine colored radical cation	Antioxidant capacity of polar extracts	Direct scavengers of free radicals (extracts from OMW than olive oil)	Papadimitriou <i>et al.</i> , 2005
79	Oil press cake (OPC)	Pretreatments of OPC to remove antimicrobial phenolic substances and then fermentation of substrates by <i>Ceratocystis moniliformis</i> and <i>Pityrosporium ovale</i>	Characteristic odor, 45% moisture, 6% residual oil, phenolic fraction up to 0.3% of fresh weight, porous structure, unlimited oxygen supply ability, substrate for yeasts and molds	Production of minor quantity of natural lactones	Laufenberg <i>et al.</i> , 2004

Adapted from Arvanitoyannis and Kassaveti, 2006a,b; 2007

as a result of high COD, increased soil pH and salinity and a reduction of soil porosity and soil aerobic community, such as fungi and actinomycetes, ferti-irrigation with OMW should be avoided (Mekki *et al.*, 2006).

Rinaldi *et al.* (2003) directly applied OMW without any preliminary treatment onto a durum wheat crop (*Triticum durum* Desf.) in order to get an insight of its potential effects on plant growth and final yield. OMW, obtained from the traditional extraction method, was applied at 50 t/ha (the maximum dose allowable by Italian law) to durum wheat. Necrotic spots on the leaves (about 20–30% of the leaf surface) and a reduction in secondary stem emergence were recorded during the vegetative phase. However, most plants in this stage finally recovered. Plant dry matter accumulation, grain and straw yield were not significantly influenced by OMW spreading.

Ramachandran *et al.* (2005) used olive oil cake (OOC) as a substrate for phytase production in solid-state fermentation using three strains of fungus *Rhizopus* spp. OOC of initial moisture 50% was fermented at 30°C for 72 hours and inoculated with *Rhizopus oligosporus* NRRL 5905, *Rhizopus oryzae* NRRL 1891 and *R. oryzae* NRRL 3562. The results indicated that all three *Rhizopus* strains produced very low titers of enzyme on OOC.

OMW originated from a three-phase centrifugal olive mill was pretreated with the following techniques: phase separation through a settling basin, dilution with water, aeration for biological degradation promotion and pH neutralization. OMW phytotoxicity was also studied on tomato seeds (*Lycopersicon esculentum*) and chicory seeds (*Cichorium intybus*). The results revealed that OMW phytotoxicity should be attributed to the presence of phenolic and organic acid (e.g. acetic and formic acids), while the most important techniques affecting OMW phytotoxicity were water dilution and aeration. In fact, to be more specific, the higher the dilution, the lower the phytotoxicity. Neutralization of pH was found rather to increase phytotoxicity considerably than decreasing it. Since settling did not manage to decrease phytotoxicity of OMW, it was not considered an appropriate and promising technique for OMW pretreatment (Komilis *et al.*, 2005).

The evaluation of the efficiency of olive mill solid wastes (OMSW) and mature compost of OMSW (COMSW) towards improving the biochemical quality of a Pb/Zn-mine tailing was investigated by Romero *et al.* (2005). The remediation effectiveness was evaluated by measuring and comparing the activities of four enzymes: dehydrogenase, β -glucosidase, urease and phosphatase. The OMSW, collected from a commercial olive oil manufacturer, was blended with olive leaves and sheep manure at ratio 7:4:1 (dw) for the compost pile formation. The compost was collected when the C/N ratio was 30/1. Samples of tailing were amended or not amended with OMSW or COMSW. The tailings amended with OMSW and compost OMSW displayed increased organic carbon levels and water-soluble carbon. The non-amended samples exhibited no enzymatic activity, while the amended treatments with OMSW inhibited the enzymatic activity and the treatments with COMSW stimulated the microbial activity, due to the increased dehydrogenase, β -glucosidase, and urease activities, which either remained stable or declined. Moreover, the increase in soluble Pb and Zn and AB-DTPA-extractable Pb and Zn was restricted by the application of OMSW as a suitable and economical method for reclaiming polluted tailings.

In Table 8.10 the disadvantages of several treatment methods with regard to applied substrate, physicochemical characteristics, and final product uses are presented.

Table 8.10 Disadvantages of several olive oil waste (substrates treated) treatment methods in conjunction with their physicochemical properties and aimed use of treated waste

No	Applied substrate	Treatment method	Physicochemical characteristics	Aimed use	Disadvantages	References
1	OMW	Centrifugation and storage at -20°C	Increase: TOC, extractable N and C, available K, Mn and Fe, soil respiration, dehydrogenase and urease activities and microbial biomass Decrease: pH, Ca and Mg, phosphatase, β -glucosidase, nitrate reductase and diphenol oxidase activities	Soil fertigation	Phytotoxicity, decline of soil germination capability	Piotrowska <i>et al.</i> , 2006
2	Green olive drupae	Enzyme extraction with cold acetone (-20°C)	Phenol oxidase activity with high specificity towards o-diphenols and p-methyl-substituted phenols	Polluted waters dephenolization	Difficult enzyme extraction from tissues – economic reasons, low operational stability that would hinder reuse	Toscano <i>et al.</i> , 2003
3	OMW	Aerobic fungal pretreatment using <i>Phanerochaete chrysosporium</i> followed by decantation and anaerobic digestion	1 Untreated OMW: toxicity, acidic, increased soil salinity 2 Treated OMW: reduced toxicity, high COD, N, P, and K, black color, pathogens-free, not toxic, low concentrations of heavy metals	Ferti-irrigation	1 Untreated OMW: increase in soil salinity, enhancement of actinomycetes 2 Treated OMW: reduction of soil porosity, reduction of the soil aerobic community	Mekki <i>et al.</i> , 2005
4	OMW	No pretreatment	–	Application on a durum wheat crop (<i>Triticum durum</i> Desf.)	Necrosis of leaves and slow emission of secondary stems	Rinaldi <i>et al.</i> , 2003
5	Olive oil cake	Solid-state fermentation (30°C , 72 h) using 3 strains of <i>Rhizopus</i> spp. (<i>R. oligosporus</i> NRRL 5905, <i>R. oryzae</i> NRRL 1891 and <i>R. oryzae</i> NRRL 3562)	–	Substrate for phytase production	Low enzyme production	Ramachandran <i>et al.</i> , 2005
6	OMW	Phase separation through settling basin, dilution with water, aeration and pH neutralization	Phenolic and organic acid content	Irrigation	Phytotoxicity due to pH neutralization technique	Komilis <i>et al.</i> , 2005
7	Olive mill solid waste (OMSW)	Composting with olive leaves and sheep manure at ratio 7:4:1 (dw)	1 Compost of OMSW: increased organic carbon and water soluble carbon, stimulation of the microbial activity and biogeochemical cycles 2 OMSW: increased organic carbon and water-soluble carbon, inhibition of enzymatic activity, increase in soluble Pb and Zn, and AB-DTPA-extractable Pb and Zn	Reclamation of Pb/Zn-mine tailings	Increase in soluble and AB-DTPA-extractable Pb and Zn by the application of OMSW and compost of OMSW	Romero <i>et al.</i> , 2005

Adapted from Arvanitoyannis and Kassaveti, 2006a, b

Table 8.11 Inputs and outputs from olive oil industry

Production process	Inputs	Outputs
Traditional process (pressing)	Olives (1 ton) Wash water (0.1–0.12 m ³) Energy (40–63 kWh)	Oil (200 kg) Solid waste (400 kg) Wastewater (600 kg)
Three-phase process	Olives (1 ton) Wash water (0.1–0.12 m ³) Fresh water for decanter (0.5–1.0 m ³) Water to polish the impure oil (10 kg) Energy (90–117 kWh)	Oil (200 kg) Solid waste (500–600 kg) Wastewater (800–950 kg) – –
Two-phase process	Olives (1 ton) Wash water (0.1–0.12 m ³) Energy (<90–117 kWh)	Oil (200 kg) Solid waste (500–600 kg) Wastewater (1000–1200 kg)

Adapted from Improlive, 2000; Azbar, 2004

Table 8.12 Costs due to various treatment schemes for a three-phase olive mill wastewater

Treatment scheme	Investment cost (€)	Operating cost/m ³ wastewater (€/m ³)	Total cost/m ³ wastewater (€/m ³)	Calculated cost/ton of olive oil (€/ton)
Forced mechanical evaporation + lagooning	180 700	6.82	10.43	52.1
Physicochemical + biological + ultrafiltration	150 600	8.68	11.69	58.4
Biological (for solids and wastewater treatment)	180 700	6.21	9.82	49.1
Physicochemical + reverse osmosis	138 600	5.27	8.04	40.2
Physicochemical + ultrafiltration	216 900	Not known	–	–
Biological (anaerobic + aerobic) + reverse osmosis	180 700	Not known	–	–
Vaccum evaporation	96 400	3.69	5.62	28.1
Forced natural evaporation	42 200	0.47	1.31	1.5
Improved natural evaporation	30 100	0.05	0.65	3.2
Mechanical biological pretreatment (biogas production) + sludge management (aerobic stabilization + solar drying)	500 000–850 000	3.5–5.5	13.5–22.5	67.5–112.5
Commercial evaporator	850 000	1	3.95	19.7

Adapted from Azbar, 2004

Inputs and outputs in olive oil industry

The olive oil industry is characterized by its great environmental impact due to the production of a highly polluted wastewater and/or a solid residue, olive skin and stone (olive husk), depending on the olive oil extraction process (Table 8.11) (Baeta-Hall *et al.*, 2005).

Olive mills generate gas emissions resulting in significant odor complaints. Many of the volatile organic acids and other low-boiling organic substances are responsible for characteristic odors that can be detected around the olive mills. Fermentation phenomena take place when OMW is stored in open ponds and/or discharged on the land

Table 8.13 Cost for treating 20 000 tons per annum with various methods

Process	Typical capital cost (€)	Typical operating cost (€)
Grate incineration	25 000 000	950 000
Gasification-pyrolysis	8 000 000–15 000 000	800 000
Composting without forced aeration	1 300 000	730 000
Composting with forced aeration	2 700 000–4 700 000	1 600 000
Separate digestion (dry method)	9 500 000–10 000 000	400 000
Co-digestion (wet method)	3 700 000–4 500 000	130 000

Adapted from <http://www.biomatnet.org/publications/1859bp.pdf>

or into natural waters (Balice *et al.*, 1986). As a result methane and other pungent gases (hydrogen sulfide, etc.) are released from pond evaporation plants and pollute waters or soil. An olive cake with high moisture content is also a source of odor nuisance, especially during warm and dry weather (Niaounakis and Halvadakis, 2006).

Azbar and coworkers (2004) evaluated the costs due to various treatment schemes for a three-phase olive mill generating 5000 m³ wastewater annually with 10 years of useful life for the treatment units, assuming 1:5 oil to wastewater weight ratio. It was concluded that the thermal treatment containing evaporation and distillation processes either by solar energy (natural evaporation) or by using electricity or natural gas are the only group of alternative methods defended on economic grounds (Tables 8.12 and 8.13).

References

Scientific references

- Abdi, N., Hamdache, F., Belhocine, D. *et al.* (2000). Enzymatic saccharification of solid residue of olive mill in a batch reactor. *Biochem Engin J* **6**, 177–183.
- Abu-El-Shar, W.Y., Gharaibeh, S.H. and Mahmoud, S. (1999). Removal of dyes from aqueous solutions using low-cost sorbents made of solid residues from olive-mill wastes (JEFT) and solid residues from refined Jordanian oil shale. *Environ Geol* **39**, 1090–1094.
- Abu-Qudais, M. (1996). Fluidised-bed combustion for energy production from olive cake. *Energy* **21**(3), 173–178.
- Adhoum, N. and Monser, L. (2004). Decolourisation and removal of phenolic compounds from olive mill wastewater by electrocoagulation. *Chem Engin Process* **43**, 1281–1287.
- Aggelis, G., Iconomou, D., Christou, M., Bokas, D., Kotzailias, S. and Christou, G. (2003). Phenolic removal in a model olive oil mill wastewater using *Pleurotus ostreatus* in bioreactor cultures and biological evaluation of the process. *Water Res* **37**, 3897–3904.
- Aissam, H., Errachidi, F., Penninckx, F., Merzouki, M. and Benlemlih, M. (2005). Production of tannase by *Aspergillus niger* HA37 growing on tannic acid and olive mill waste waters. *World J Microbiol Biotechnol* **21**, 609–614.

- Albuquerque, J.A., Gonzalez, J., Garcia, D. and Cegarra, J. (2006). Composting of a solid olive-mill by-product ('alperujo') and the potential of the resulting compost for cultivating pepper under commercial conditions. *Waste Manage* **26**(6), 620–626.
- Alcaide, E.M. and Nefzaou, A. (1996). Recycling of olive oil by-products, possibilities of utilisation in animal nutrition. *Int Biodeter Biodegrad* **38** (3–4), 221–235.
- Alfano, G., Belli, C., Lustrato, G. and Ranalli, G. (2006). Water and energy saving in olive oil mill plants by wastewater reuse. In *Proceedings of Second International Seminar Biotechnology and Quality of Olive Tree Products around the Mediterranean Basin* held in Marsala, Italy, 5–10 November. Edited by Olivebioteq.
- Al-Khalid, T.T., Haimour, N.M., Sayed, S.A. and Akash, B.A. (1998). Activation of olive-seed waste residue using CO₂ in a fluidised-bed reactor. *Fuel Process Technol* **57**, 55–64.
- Alkhamis, T.M. and Kablan, M.M. (1999). Olive cake as an energy source and catalyst for oil shale production of energy and its impact on the environment. *Energy Convers Manage* **40**, 1863–1870.
- Amat di San Filippo, P. and Rinaldi, A. (1986). Acque di vegetazione dell'industria olearia, Materia prima o rifiuto inquinante? *Riv Merceol* **25**, 183–199.
- Amat di San Filippo, P., Caredda, E. and Schivo, M. (1987). Biomasse utili da acque di vegetazione dell'industria olearia. *Riv Merceol* **26**, 255–264.
- Amat, A.M., Arques, A., Beneyto, H., Garcia, A., Miranda, M.A. and Segui, S. (2003). Ozonisation coupled with biological degradation for treatment of phenolic pollutants, a mechanistically based study. *Chemosphere* **53**, 79–86.
- Arienzo, M. and Capasso, R. (2000). Analysis of metal cations and inorganic anions in olive oil mill wastewaters by atomic absorption spectroscopy and ion chromatography. Detection of metals bound to the organic polymeric fraction. *J Agricult Food Chem* **48**, 1405–1410.
- Arjona, R., Garcia, A. and Ollero, P. (1999). The drying of alperujo, a waste product of the olive oil mill industry. *J Food Engin* **41**, 229–234.
- Arvanitoyannis, I.S. and Kassaveti, A. (2006a). Current and potential uses of composted olive oil waste. *Int J Food Sci Technol* **42**, 281–295.
- Arvanitoyannis, I.S. and Kassaveti, A. (2006b). Current and potential uses of treated (bioremediation, anaerobic digestion) olive oil waste. *Int J Food Sci Technol* (in press).
- Arvanitoyannis, I.S. and Kassaveti, A. (2007). Current and potential uses of thermally treated olive oil waste. *Int J Food Sci Technol* **42**(7), 852–867.
- Arvanitoyannis, I.S., Kassaveti, A. and Stefanatos, S. (2007). Olive oil waste treatment: a comparative and critical presentation methods. Advantages & disadvantages. *Critical Reviews in Food Science and Nutrition* **47**, 187–229.
- Assas, N., Ayed, L., Marouani, L. and Hamdi, M. (2002). Decolorisation of fresh and stored-black olive mill wastewaters by *Geotrichum candidum*. *Process Biochem* **38**, 361–365.
- Atimtay, A.T. and Topal, H. (2004). Co-combustion of olive cake with lignite coal in a circulating fluidised bed. *Fuel* **83**, 859–867.
- Attom, M.F. and Al-Sharif, M.M. (1998). Soil stabilisation with burned olive waste. *Appl Clay Sci* **13**, 219–230.

- Aveni, A. and Lamarca, A. (1986). Biogas recovery from olive-oil mill wastewater by anaerobic digestion. In *Anaerobic digestion, results of research and demonstration projects* (M.P. Ferranti, G.L. Ferrero and P.L. Hermite, eds), pp. 236–240. Elsevier Applied Science, London, U.K.
- Aveni, A. (1983). Biogas recovery from olive oil production waste by anaerobic digestion, R and D program – recycling of urban and industrial waste Broni (Pavia), pp. 17–19. Istituto Ricerche, Breda, Italy.
- Azbar, N. (2004). A review of waste management options in olive oil production. *Crit Rev Environ Sci Technol* **34**, 209–247.
- Bacaoui, A., Yaacoibi, A., Dahbi, A. *et al.* (2001). Optimisation of conditions for the preparation of activated carbons from olive-waste cakes. *Carbon* **39**, 425–432.
- Baddi, G.A., Albuquerque, J.A., Gonzalez, J., Cegarra, J. and Hadi, M. (2003). Chemical and spectroscopic analyses of organic matter transformations during composting of olive mill wastes. *Int Biodeter Biodegrad* **54**, 39–44.
- Baddi, G.A., Albuquerque, J.A., Gonzalez, J., Cegarra, J. and Hadi, M. (2004). Chemical and spectroscopic analyses of organic matter transformations during composting of olive mill wastes. *Int Biodeter Biodegrad* **54**(1), 39–44.
- Baeta-Hall, L., Ceu Saagua, M.C., Lourdes Bartolomeu, M., Anselmo, A.M. and Fernanda Rosa, M. (2005). Bio-degradation of olive oil husks in composting aerated piles. *Bioresource Technol* **96**, 69–78.
- Balice, C. (1990). Effect of olive-oil mill wastes on soil fertility. In *Tratamiento de Alpechines*, Cordoba, Spain.
- Balice, V., Carrieri, C., Cera, O. and Di Fazio, A. (1986). Natural biodegradation in olive mill effluents stored in open basins. *Proceedings of International Symposium On Olive By-Products Valorisation*, Seville, Spain, 4–7 March.
- Barnwal, B.K. and Sharma, M.P. (2005). Prospects of biodiesel production from vegetable oils in India. *Renew Sustain Energy Rev* **9**(4), 363–378.
- Bas, F.J., Colinet, M.J., Lobo, J. and Manso, A. (2001). The olive tree as an energy source in the Mediterranean area, Andalusia. In *First World Conference on Biomass for Energy and Industry*, vol. I, (S.Kyritsis, A.A.C.M. Beenackers, P. Helm, A. Grassi and D. Chiaramonti, eds), pp. 393–395. James & James (Science Publishers) Ltd, London.
- Beccari, M., Bonemazzi, F., Majone, M. and Riccardi, C. (1996). Interaction between acidogenesis and methanogenesis in the anaerobic treatment of olive oil mill effluents. *Water Res* **30**(1), 183–189.
- Belfort, G., Davis, R.H. and Zydney, A.L. (1994). The behaviour of suspensions and macromolecular solutions in crossflow microfiltration. *J Membr Sci* **96**(1/2), 1–58.
- Benitez, E., Sainz, H. and Nogales, R. (2005). Hydrolytic enzyme activities of extracted humic substances during the vermicomposting of a lignocellulosic olive waste. *Bioresource Technol* **96**, 785–790.
- Benitez, F.J., Beltran-Heredia, J., Acero, J.L. and Pinilla, M.L. (1997). Ozonation kinetics of phenolic acids present in wastewaters from olive oil mills. *Ind Eng Chem Res* **36**, 638–644.
- Benitez, F.J., Beltran-Heredia, J., Peres, A.J. and Dominguez, J.R. (2000). Kinetics of p-hydroxybenzoic acid photodecomposition and ozonation in a batch reactor. *J Hazardous Mater* **B73**, 161–178.

- Ben Rouina, B. (1994). Répercussions agronomiques de l'épandage des margines comme fertilisant, *International conference on Land and Water Resources Management in the Mediterranean Region II*, 1994, pp. 583–594.
- Blanquez, P., Caminal, G., Sarra, M., Vicent, M.T. and Gabarrell, X. (2002). Olive oil mill waste waters decoloration and detoxification in a bioreactor by the white rot fungus *Phanerochaete flavido-alba*. *Biotechnol Prog* **18**, 660–662.
- Boari, G., Brunetti, A., Passino, R. and Rozzi, A. (1984). Anaerobic digestion of olive oil mill wastewaters. *Agric Wastes* **16**, 161–175.
- Borja, R., Alba, J. and Banks, C.J. (1996). Anaerobic digestion of wash waters derived from the purification of virgin olive oil using a hybrid reactor combining a filter and a sludge blanket. *Process Biochem* **31**(3), 219–224.
- Bouزيد, O., Navarro, D., Roche, M. *et al.* (2005). Fungal enzymes as a powerful tool to release simple phenolic compounds from olive oil by-product. *Process Biochem* **40**, 1855–1862.
- Boz, O., Dogan, M.N. and Albay, F. (2003). Olive processing wastes for weed control. *Weed Res* **43**, 439–443.
- Bridgewater, A.V. and Grassi, G. (1991). *Biomass Pyrolysis Liquids Upgrading and Utilisation*. Elsevier, London.
- Cabrera, F., Lopez, R., Martinez-Borditi, A., Dupuy de Lomeb, E. and Murillo, J.M. (1996). Land treatment of olive oil mill wastewater. *Int Biodeter Biodegrad* **38**(3–4), 215–225.
- Caglar, A. and Demirbas, A. (2002). Hydrogen rich gas mixture from olive husk via pyrolysis. *Energy Conversion Manage* **43**(1), 109–117.
- Capasso, R. (1997). The chemistry, biotechnology and ecotoxicology of the polyphenols naturally occurring in vegetable wastes. In *Current topics in phytochemistry* (J.Asakawa, O.R. Gottlieb, G.H.N. Towers, H. Wagner and P.G. Waterman, eds), **1**, 145–156. Research Trends, Trivandrum.
- Capasso, R., De Martino, A. and Arienzo, M. (2002). Recovery and characterisation of the metal polymeric organic fraction (polymerin) from olive oil mill wastewaters. *J Agricult Food Chem* **50**, 2846–2855.
- Capasso, R., Evidente, A., Avolio, S. and Solla, F. (1999). A highly convenient synthesis of hydroxytyrosol and its recovery from agricultural waste waters. *J Agricult Food Chem* **47**, 1745–1748.
- Capasso, R., Pigna, M., De Martino, A., Pucci, M., Sannino, F. and Violante, A. (2004). Potential remediation of waters contaminated with Cr(iii), Cu, and Zn by sorption on the organic polymeric fraction of olive mill wastewater (polymerin) and its derivatives. *Environmen Sci Technol* **38**, 5170–5176.
- Caputo, A.C., Scacchia, F. and Pelagagge, P.M. (2003). Disposal of by-products in olive oil industry, waste-to-energy solutions. *Appl Thermal Engin* **23**, 197–214.
- Casa, R., Annibale, A.D., Pieruccetti, F., Stazi, S.R., Giovannozzi, G. and Lo Cascio, B. (2003). Reduction of the phenolic components in olive-mill wastewater by an enzymatic treatment and its impact on durum wheat (*Triticum durum* Desf.) germinability. *Chemosphere* **50**, 959–966.
- Cayuela, M.L., Sánchez-Monedero, M.A. and Roig, A. (2006). Evaluation of two different aeration systems for composting two-phase olive mill wastes. *Process Biochem* **41**(3), 616–623.

- Cereti, C.F., Rossini, F., Federici, F., Quarantino, D., Vassilev, N. and Fenice, M. (2004). Reuse of microbially treated olive mill wastewater as fertiliser for wheat (*Triticum durum* Desf). *Bioresource Technol* **91**, 135–140.
- Chang, Y. and Hudson, H.J. (1967). The fungi of wheat straw compost. *Trans Br Mycol Soc* **50**(4), 649–666.
- Chartzoulakis, K., Psarras, G., Moutsopoulou, M. and Stefanoudaki, E. (2006). Application of olive mill wastewater on olive orchards: effect on soil properties, plant performance and the environment. In *Proceedings of Second International Seminar Biotechnology and Quality of Olive Tree Products around the Mediterranean Basin* held in Marsala, Italy, 5–10 November. Edited by Olivebioteq.
- Chatjipavlidis, I., Antonakou, M., Demou, D., Flouri, F. and Balis, C. (1996). Bio-fertilisation of olive oil mills liquid wastes. The pilot plant in Messinia, Greece. *Int Biodeter Biodegrad* **38**(3–4), 183–187.
- Cheryan, M. (1986). *Ultrafiltration handbook*. Technomic Publishing Company, Lancaster.
- Chiang, L.C., Chang, J.E. and Wen, T.C. (1995). Indirect oxidation effect in electrochemical oxidation treatment of landfill leachate. *Water Res* **29**, 671–678.
- Chum, H.L. and Overend, R.P. (2001). Biomass and renewable fuels. *Fuel Process Technol* **71**, 187–195.
- Cimino, G., Cappello, R.M., Caristi, C. and Toscano, G. (2005). Characterisation of carbons from olive cake by sorption of wastewater pollutants. *Chemosphere* **61**(7), 947–955.
- Cliffe, K.R. and Patumsawad, S. (2001). Co-combustion of waste from olive oil production with coal in a fluidised bed. *Waste Manage* **21**, 49–53.
- Comninellis, C. and Nerini, A. (1995). Anodic oxidation of phenol in the presence of NaCl for wastewater treatment. *J Appl Electrochem* **25**, 23.
- Comninellis, C. and Pugarin, C. (1991). Anodic oxidation of phenol for waste water treatment. *J Appl Electrochem* **21**, 415–418.
- Comninellis, C. (1992). The electrochemical treatment of wastewater. *GWA* **11**, 792–797.
- Comninellis, C. (1994). Electrocatalysis in the electrochemical conversion/combustion of organic pollutants for the wastewater treatment. *Electrochim Acta* **39**(11/12), 1857.
- D'Annibale, A., Stazi, S.R., Vinciguerra, V., Di Mattia, E. and Giovannozzi Sermanni, G. (1999). Characterisation of immobilized laccase from *Lentinula edodes* and its use in olive-mill wastewater treatment. *Process Biochem* **34**, 697–706.
- Dalis, D. (1991). Optimisation of the C/N ratio during the anaerobic digestion of olive-oil waste waters. In *Proceedings of 13th National Congress of the Hellenic Biological Sciences Union*, Heraklion, Crete (in Greek).
- Dalis, D., Anagnostidis, K., Lopez, A., Letsiou, I. and Hartmann, L. (1996). Anaerobic digestion of total raw olive-oil wastewater in a two-stage pilot-plant (up-flow and fixed-bed bioreactors). *Bioresource Technol* **57**, 237–243.
- Dalis, D., Hartmann, L. and Anagnostidis, K. (1982). Anaerobic treatment of olive oil waste waters. R&D program – recycling of urban and industrial waste (RUW-056), Brussels, Belgium.
- De la Rubia, T., Linares, A., Pérez, J., Muñoz-Dorado, R.J. and Martínez, J. (2002). Characterisation of manganese-dependent peroxidase isoenzymes from the ligninolytic fungus *Phanerochaete flavidio-alba*. *Res Microbiol* **153**, 547–554.

- Della Monica, M., Agostizno, A. and Ceglie, A. (1980). An electrochemical sewage treatment process. *J Appl Electrochem* **10**, 527–533.
- Demirbas, A. (2003). Biodiesel fuels from vegetable oils via catalytic and non-catalytic supercritical alcohol transesterifications and other methods, a survey. *Energy Conversion Manage* **44**, 2093–2109.
- Dhourib, A., Aloui, F., Hamad, N. and Sayadi, S. (2006). Pilot-plant treatment of olive mill wastewaters by *Phanerochaete chrysosporium* coupled to anaerobic digestion and ultrafiltration. *Process Biochem* **41**(1), 159–167.
- Di Gioia, D., Barberio, C., Spagnesi, S., Marchetti, L. and Fava, F. (2002). Characterisation of four olive-mill-wastewater indigenous bacterial strains capable of aerobically degrading hydroxylated and methoxylated monocyclic aromatic compounds. *Arch Microbiol* **178**, 208–217.
- Di Gioia, D., Bertin, L., Fava, F. and Marchetti, L. (2001). Biodegradation of hydroxylated and methoxylated benzoic, phenylacetic and phenylpropenoic acids present in olive mill wastewaters by two bacterial strains. *Res Microbiol* **152**, 83–93.
- Di Gioia, D., Fava, F., Bertin, L. and Marchetti, L. (2002). Biodegradation of synthetic and naturally occurring mixtures of monocyclic aromatic compounds present in olive mill wastewaters by two aerobic bacteria. *Appl Microbiol Biotechnol* **55**, 619–626.
- Dias, A. A., Bezerra, R.M. and Nazare-Pereira, A. (2004). Activity and elution profile of laccase during biological decolorisation and dephenolisation of olive mill wastewater. *Bioresource Technol* **92**, 7–13.
- Dorado, M. P., Ballesteros, E., Arnal, J.M., Gomez, J. and Lopez Gimenez, F.J. (2003a). Exhaust emissions from a diesel engine fueled with transesterified waste olive oil. *Fuel* **82**, 1311–1315.
- Dorado, M. P., Ballesteros, E., Arnal, J.M., Gomez, J. and Lopez Gimenez, F.J. (2003b). Testing waste olive oil methyl ester as a fuel in a diesel engine. *Energy Fuels* **17**, 1560–1565.
- Dorado, M.P., Ballesteros, E., Mittelbach, M. and Lopez, F.J. (2004). Kinetic parameters affecting the alkali-catalyzed transesterification process of used olive oil. *Energy Fuels* **18**, 1457–1462.
- Doymaz, I., Gorel, O. and Akgun, N.A. (2004). Drying characteristics of the solid by-product of olive oil extraction. *Biosystems Engin* **88**(2), 213–219.
- Ehaliotis, C., Papadopoulou, K., Kotsou, M., Mari, I. and Balis, C. (1999). Adaptation and population dynamics of *Azotobacter vinelandii* during aerobic biological treatment of olive-mill wastewater. *FEMS Microbiol Ecol* **30**, 301–311.
- Ehaliotis, C., Zervakis, G.I. and Karavitis, P. (2005). Residues and by-products of olive-oil mills for root-zone heating and plant nutrition in organic vegetable production. *Sci Horticult* **106**(3), 293–308.
- El-Sheikh, A.H., Newman, A.P., Al-Daffaee, H.K., Phull, S. and Cresswell, N. (2004). Characterisation of activated carbon prepared from a single cultivar of Jordanian Olive stones by chemical and physicochemical techniques. *J Analyt Appl Pyrolysis* **71**, 151–164.
- Encinar, J.M., Gonzalez, J.F. and Gonzalez, J. (2000). Fixed-bed pyrolysis of *Cynara cardunculus* L. Product yields and compositions. *Fuel Process Technol* **68**, 209–222.

- Encinar, J.M., Gonzalez, J.F. and Rodriguez-Reinares, A. (2005). Biodiesel from used frying oil; variables affecting the yields and characteristics of the biodiesel. *Indust Engin Chem Res* **44**, 5491–5499.
- Ergüder, T.H., Güven, E. and Demirer, G.N. (2000). Anaerobic treatment of olive mill wastes in batch reactors. Department of Environmental Engineering, Middle East Technical University, Ankara, Turkey.
- Eroglu, E., Gunduz, U., Yucel, M., Turker, L. and Eroglu, I. (2004). Photobiological hydrogen production by using olive mill wastewater as a sole substrate source. *Int J Hydrogen Energy* **29**, 163–171.
- Ettayebi, K. (2003). Biodegradation of polyphenols with immobilized *Candida tropicalis* under metabolic induction. *FEMS Microbiol Lett* **223**, 215–219.
- Fadil, K. (2003). Aerobic biodegradation and detoxification of wastewaters from the olive oil industry. *Int Biodeter Biodegrad* **51**, 37–41.
- Fakharedine, N., Alburquerque, J.A., Cegarra, J., Ouchdouch, Y., El Hadrami, I. and Hafidi, M. (2006). Reduction of the phenolic compounds in olive-mill wastewater using selected yeasts. In *Proceedings of Second International Seminar Biotechnology and Quality of Olive Tree Products around the Mediterranean Basin* held in Marsala, Italy, 5–10 November. Edited by Olivebioteq.
- Fedeli, E. and Camurati, F. (1981). Valorisation des margines et des grignons épuisés par r récupération de quelques composants. *Séminaire International sur la valorisation des sous-produits de l'olivier PNUD/FAO/COI*. Monastir, Tunisia, December 1981.
- Fernandez-Bolanos, J., Felizon, B., Heredia, A., Rodriguez, R., Guillen, R. and Jimenez, A. (2001). Steam-explosion of olive stones, hemicellulose solubilisation and enhancement of enzymatic hydrolysis of cellulose. *Biosource Technol* **79**, 53–61.
- Fernandez-Bolanos, J., Rodriguez, G., Rodriguez, R., Heredia, A., Guillen, R. and Jimenez, A. (2002). Production in large quantities of highly purified hydroxytyrosol from liquid-solid waste of two-phase olive oil processing or 'alperujo'. *J Agricult Food Chem* **50**, 6804–6811.
- Fiestas Ros de Ursinos, R.J. (1982). Depuracion anaerobia del alpechin como, fuente de energia. *Grasas Aceites* **5**, 265–270.
- Finstein, M.S., Miller, F.C., Mac Gregor, S.T. and Psarianos, K.M. (1985). The Rutgers strategy for composting, process design and control. EPA Project Summary (EPA 600/S2-85/059). US Environmental Protection Agency, Washington, DC.
- Finstein, M.S., Miller, F.C., Strom, P.F., Mcgregor, S.T. and Psarianos, K.M. (1983). Composting ecosystems management for waste treatment. *Biotechnology* **1**, 347–353.
- Fiorentino, A., Gentili, A., Isidori, M. *et al.* (2003). Environmental effects caused by olive mill wastewaters, toxicity comparison of low-molecular-weight phenol components. *J Agricult Food Chem* **51**, 1005–1009.
- Fki, I., Allouche, N. and Sayadi, S. (2005). The use of polyphenolic extract, purified hydroxytyrosol and 3,4-dihydroxyphenyl acetic acid from olive mill wastewater for the stabilisation of refined oils, a potential alternative to synthetic antioxidants. *Food Chem* **93**, 197–204.
- Flouri, F., Sotirchos, D., Ioannidou, S. and Balis, C. (1996). Decolorisation of olive oil mill liquid wastes by chemical and biological means. *Int Biodeter Biodegrad* 189–192.

- Galiatsatou, P., Metaxas, M. and Kasselouri-Rigopoulou, V. (2002). Adsorption of zinc by activated carbons prepared from solvent extracted olive pulp. *J Hazardous Mater* **B91**, 187–203.
- Ganan, J., Turegano, J.P., Calama, G., Roman, S. and Al-Kassir, A. (2006). Plant for the production of activated carbon and electric power from the gases originated in gasification processes. *Fuel Process Technol* **87**, 117–122.
- Garcia-Garcia, I., Jimenez Pena, P.R., Bonilla Venceslada, J.L., Martin Martin, A., Martin Santos, M.A. and Ramos Gomez, E. (2000). Removal of phenol compounds from olive mill wastewater using *Phanerochaete chrysosporium*, *Aspergillus niger*, *Aspergillus terreus* and *Geotrichum candidum*. *Process Biochem* **35**, 751–758.
- Garcia-Barrionuevo, A., Moreno, E., Quevedo-Sarmiento, J., Gonzalez-Lopez, J. and Ramos Cormenzana, A. (1992). Effect of waste waters from olive oil mills (alpechin) on *Azotobacter* nitrogen fixation in soil. *Soil Biol Biochem* **24**, 281–283.
- Garcia-Gomez, A., Bernal, M.P. and Roig, A. (2002a). Growth of ornamental plants in two composts prepared from agroindustrial wastes. *Bioresource Technol* **83**, 81–87.
- Garcia-Gomez, A., Roig, A. and Bernal, M.P. (2002b). Composting of the solid fraction of olive mill wastewater with olive leaves, organic matter degradation and biological activity. *Biosource Technol* **86**, 59–64.
- Garcia-Ibanez, P., Sanchez, M. and Cabanillas, A. (2006). Thermogravimetric analysis of olive-oil residue in air atmosphere. *Fuel Process Technol* **87**, 103–107.
- Gavala, H.N., Skiadas, I.V., Nikolaos, A.B. and Lyberatos, G. (1996). Anaerobic digestion of agricultural industries wastewaters. *Water Sci Technol* **34**, 67–75.
- Georgacakis, D. and Dalis, D. (1993). Controlled anaerobic digestion of settled olive-oil mill wastewater. *Bioresource Technol* **46**, 221–226.
- Gharaibeh, S.H., Moore, S.V. and Buck, A. (1998). Effluent treatment of industrial wastewater using processed solid residue of olive mill products and commercial activated carbon. *J Chem Technol Biotechnol* **71**, 291–298.
- Gharsallah, N., Labat, M., Aloui, F. and Sayadi, S. (1999). The effect of *Phanerochaete chrysosporium* pretreatment of olive mill waste waters on anaerobic digestion. *Resources Conservation Recyc* **27**, 187–192.
- Gianfreda, L., Sanninoa, F., Raoa, M.A. and Bollag, J.M. (2003). Oxidative transformation of phenols in aqueous mixtures. *Water Res* **37**, 3205–3215.
- Gonzalez-Lopez, J., Pozo, C., Martinez-Toledo, M.V., Rodelas, B. and Salmeron, V. (1996). Production of polyhydroxyalkanoates by *Azotobacter chroococcum* H23 in wastewater from olive oil mills (alpechin). *Int Biodeter Biodegrad* 271–276.
- Greco, G. Jr, Toscanoa, G., Cioffi, M., Gianfreda, L. and Sannino, F. (1999). Dephenolisation of olive mill waste-waters by olive husk. *Wat Res* **33**(13), 3046–3050.
- Haddadin, M.S., Abdulrahim, S.M., Al-Khawalden, G.Y. and Robinson, R.K. (1999). Solid state fermentation of waste pomace from olive processing. *J Chem Technol Biotechnol* **47**, 613–918.
- Haddadin, M.S., Al-Natour, R., Al-Qsous, S. and Robinson, R.K. (2002). Bio-degradation of lignin in olive pomace by freshly-isolated species of Basidiomycete. *Bioresource Technol* **82**(2), 131–137.
- Hamdi, M. (1993). Future prospects and constraints of olive oil mill wastewater use and treatment: a review. *Bioprocess Engin* **8**, 209.

- Haykiri-Acma, H., Yaman, S. and Kucukbayrak, S. (2006). Gasification of biomass chars in steam-nitrogen mixture. *Energy Conversion Manage* **47**, 1004–1013.
- Hytiris, N., Kapellakis, I.E., La Roi de, R. and Tsagarakis, K.P. (2004). The potential use of olive mill sludge in solidification process. *Resources Conservation Recyc* **40**, 129–139.
- Iconomou, D., Papanikolaou, S., Christou, M., Dimou, D. and Aggelis, G. (2006). Biotreatment of olive oil mill wastewaters using *Pleurotus* spp. In *Proceedings of Second International Seminar Biotechnology and Quality of Olive Tree Products around the Mediterranean Basin* held in Marsala, Italy, 5–10 November. Edited by Olivebioteq.
- Improlive (2000). Improvements of treatments and validation of the liquid-solid waste from the two-phase olive oil extraction. Annex A2: Final Report, Fair CT96 1420 (<http://unpan1.un.org/intradoc/groups/public/documents/ARADO/UNPA020869.PDF>)
- Inan, H., Dimoglo, A., Simsek, H. and Karpuzcu, M. (2004). Olive oil mill wastewater treatment by means of electro-coagulation. *Separat Purific Technol* **36**, 23–31.
- Israilides, C.J., Vlyssides, A.G., Mourafeti, N.V. and Karvouni, G. (1997). Olive oil wastewater treatment with the use of an electrolysis system. *Bioresource Technol* **61**, 163–170.
- Jaouani, A., Guillen, F., Penninckx, M.J., Martinez, A.T. and Martinez, M.J. (2005). Role of *Pycnoporus coccineus* laccase in the degradation of aromatic compounds in olive oil mill wastewater. *Enzyme Microb Technol* **36**(4), 478–486.
- Jaouani, A., Sayadi, S., Vanthourhout, M. and Penninck, M.J. (2003). Potent fungi for decolourisation of olive oil mill wastewaters. *Enzyme Microb Technol* **33**, 802–809.
- Kachouri, F. and Moktar, H. (2004). Enhancement of polyphenols in olive oil by contact with fermented olive mill wastewater by *Lactobacillus plantarum*. *Process Biochem* **39**(7), 841–845.
- Kalmis, E. and Sargin, S. (2004). Cultivation of two *Pleurotus* species on wheat straw substrates containing olive mill waste water. *Int Biodeter Biodegrad* **53**, 43–47.
- Kestioglu, K., Yonar, T. and Azbar, N. (2005). Feasibility of physico-chemical treatment and advanced oxidation processes (AOPs) as a means of pretreatment of olive mill effluent (OME). *Process Biochem* **40**, 2409–2416.
- Komilis, D.P., Karatzas, E. and Halvadakis, C.P. (2005). The effect of olive mill wastewater on seed germination after various pretreatment techniques. *J Environ Manage* **74**, 339–348.
- Kotsou, M., Mari, I., Lasaridi, K., Chatzipavlidis, I., Balis, C. and Kyriacou, A. (2004). The effect of olive oil mill wastewater (OMW) on soil microbial communities and suppressiveness against *Rhizoctonia solani*. *Appl Soil Ecol* **26**, 113–121.
- Kusakabe, K., Nishida, H., Marooka, S. and Kato, Y. (1986). Simultaneous electrochemical removal of copper and chemical oxygen demand using a packed-bed electrode cell. *J Appl Electrochem* **16**, 121–126.
- Kyriacou, A., Lasaridi, K.E., Kotsou, M., Balis, C. and Pilidis, G. (2005). Combined bioremediation and advanced oxidation of green table olive processing wastewater. *Process Biochem* **40**(3–4), 1401–1408.
- Lanciotti, R., Gianotti, A., Baldi, D. et al. (2004). Use of *Yarrowia lipolytica* strains for the treatment of olive mill wastewater. *Biosource Technol* **96**, 317–322.
- Laufenberg, G., Rosato, P. and Kunz, B. (2004). Adding value to vegetable waste, oil press cakes as substrates for microbial decalactone production. *Eur J Lipid Sci Technol* **106**, 207–217.

- Lin, S.H. and Peng, C.F. (1994). Treatment of textile wastewater by electrochemical method. *Wat Res* **28**, 277–282
- Loneragan, G. and Baker, W.L. (1995). Comparative study of substrates of fungal laccase. *Lett Appl Microbiol* **21**, 31–33.
- Lopez, M.J. and Ramos-Cormenzana, A. (1996). Xanthan production from olive-mill wastewaters. *Int Biodeter Biodegrad* **38**(3–4), 263–270.
- Lopez, M.J., Moreno, J. and Ramos-Cormenzana, A. (2000). *Xanthomonas campestris* strain selection for xanthan production from olive mill wastewaters. *Water Res* **35**(7), 1828–1830.
- Lopez-Villalta, L.C. (ed.) (1998). *The olive tree, the oil, the olive*. International Olive Oil Council Publications, Madrid.
- Manios, T. (2004). The composting potential of different organic solid wastes, experience from the island of Crete. *Environ Int* **29**, 1079–1089.
- Mari, I., Ehaliotis, C., Kotsou, M. and Balis, C. (2003). Respiration profiles in monitoring the composting of by-products from the olive oil agro-industry. *Bioresource Technol* **87**, 331–336.
- Marques, I.P. (2001). Anaerobic digestion treatment of olive mill wastewater for effluent re-use in irrigation. *Desalination* **137**, 233–239.
- Marsilio, V., Di Giovacchino, L., Costantini, N., Di Serio, M.G. and Vito, R. (2006). Effect of the olive mill wastewater (OMW) spreading for many years on olive trees and grapevine cultivations. In *Proceedings of Second International Seminar Biotechnology and Quality of Olive Tree Products around the Mediterranean Basin* held in Marsala, Italy, 5–10 November. Edited by Olivebioteq.
- Martirani, L., Giardina, P., Marzullo, L. and Sannia, G. (1996). Reduction of phenol content and toxicity in olive oil mill waste waters with the lignolytic fungus *Pleurotus ostreatus*. *Wat Res* **30**(8), 1914–1918.
- Masghouni, M. and Hassairi, M. (2000). Energy applications of olive-oil industry by-products, I. The exhaust foot cake. *Biomass Bionergy* **18**, 257–232.
- McKendry, P. (2002). Energy production from biomass (part 1), Overview of biomass. *Bioresource Technol* **83**, 37–46.
- Mekki, A., Dhoub, A. and Sayadi, S. (2006). Changes in microbial and soil properties following amendment with treated and untreated olive mill wastewater. *Microbiol Res* **161**(2), 93–101.
- Meysami, B. and Kasaeian, A.B. (2005). Use of coagulants in treatment of olive oil wastewater model solutions by induced air flotation. *Bioresource Technol* **96**, 303–307.
- Montedoro, G. F. and Petruccioli, G. (1986). Interventi chimici e fisici sulle acque di vegetazione e abbattimento parziale del loro stesso inquinamento. Acts of Round Table on the disposal of olive oil mill wastewaters. Accademia Nazionale dell'Olivo Spoleto, 10 novembre.
- Montemurro, F., Convertini, G. and Ferri, D. (2004). Mill wastewater and olive pomace compost as amendments for rye-grass. *Agronomie* **24**, 481–486.
- Nabi, N., Aimar, P. and Meireles, M. (2000). Ultrafiltration of an olive oil emulsion stabilized by an anionic surfactant. *J Membr Sci* **166**, 177–188.
- Nasini, L., Proietti, P., Famiani, F. et al. (2006). Effect olive husk on soil fertility and olive activity. In *Proceedings of Second International Seminar Biotechnology and Quality*

- of Olive Tree Products around the Mediterranean Basin* held in Marsala, Italy, 5–10 November. Edited by Olivebioteq.
- Naumczyk, J., Szpyrkowicz, L., De Faverrì, M.D. and Zilio Grandi, F. (1996). Electrochemical treatment of tannery wastewater containing high strength pollutants. *Trans I Chem E* **74**, Part B 59–68.
- Niaounakis, M. and Halvadakis, C.P. (2006). *Olive processing waste management: Literature review and patent survey*, pp. 28, 80–81, 93, 151, 154. Elsevier Ltd, Oxford.
- Nico, A.I., Jimenez-Diaz, R.M. and Castillo, P. (2004). Control of root-knot nematodes by composted agro-industrial wastes in potting mixtures. *Crop Protect* **23**, 581–587.
- Ntougias, S., Kavroulakis, N., Ehaliotis, C., Papadopoulou, K.K. and Zervakis, G. (2006). Isolation and screening of indigenous microorganisms capable to detoxify wastese of the olive oil industry. In *Proceedings of Second International Seminar Biotechnology and Quality of Olive Tree Products around the Mediterranean Basin* held in Marsala, Italy, 5–10 November. Edited by Olivebioteq.
- Pacifico, A. (1989). Acque di vegetazione. In *Agricoltura ed Innovazione. Notiziario dell'ENEA e di RENAGRI* **11**, 33–37.
- Papadimitriou, E.K., Chatjipavlidis, I. and Balis, C. (1997). Application of composting to olive mill wastewater treatment. *Environ Technol* **18**, 101–107.
- Papadimitriou, V., Maridakis, G.A., Sotiroudis, T.A. and Xanakis, A. (2005). Antioxidant activity of polar extracts from olive oil and olive mill wastewaters, an EPR and photometric study. *Eur J Lipid Sci Technol* **107**(7–8), 513–520.
- Papafotiou, M., Phsyhalou, M.K., Chatzipavlidis, I. and Chronopoulos J. (2004). Olive-mill wastes compost as growing medium component for the production of poinsettia. *Sci Horticult* **102**, 167–175.
- Paredes, C., Bernal, M.P., Roig, A. and Cegarra, G. (2001). Effects of olive mill wastewater addition in composting of agroindustrial and urban wastes. *Biodegradation* **12**, 225–234.
- Paredes, C., Cegarra, J., Bernal, M.P. and Roig, A. (2004). Influence of olive mill wastewater in composting and impact of the compost on a Swiss chard crop and soil properties. *Environ Int* **31**(2), 305–312.
- Paredes, C., Cegarra, J., Roig, A., Sanchez-Monedero, M.A. and Bernal, M.P. (1999). Characterisation of olive mill wastewater (alpechin) and its sludge for agricultural purposes. *Bioresource Technol* **67**, 111–115.
- Peredes, M.J., Monteoliva-Sanchez, M., Moreno, E., Perez, J., Ramos-Cormenzana, A. and Martinez, J. (1987). Effect of waste waters from olive oil extraction plant on the bacterial population of soil. *Chemosphere*, **15**, 659–664.
- Pérez, J., de la Rubia, T. and Martínez, J. (1996). Purification and partial characterisation of a laccase from the white-rot fungus *Phanerochaete flavidio-alba*. *Appl Environ Microbiol* **62**, 4263–4267.
- Pérez, J., Hernandez, M.T., Ramos Cormenzana, A. and Martínez, J. (1987). *Grasas Aceites*, **38**, 367.
- Périé, F.H., and Gold, M.H. (1991). Manganese regulation of manganese peroxidase expression and lignin degradation by the white rot fungus *Dichomitus squalens*. *Appl Environ Microbiol* **57**, 2240–2245.
- Piotrowska, A., Iamarino, G., Rao, M.A. and Gianfreda, L. (2006). Short-term effects of olive mill waste water (OMW) on chemical and biochemical properties of a semiarid Mediterranean soil. *Soil Biol Biochem* **38**(3), 600–610.

- Piperidou, C.I., Chaidou, C.I., Stalikas, C.D., Soulti, K., Pilidis, G.A. and Balis, C. (2000). Bioremediation of olive oil mill wastewater, chemical alternations induced by *Azotobacter vinelandii*. *J Agric Food Chem* **48**(5), 1941–1948.
- Potoglou, D., Kouzeli-Katsiri, A. and Haralambopoulos, D. (2003). Solar distillation of olive mill wastewater. *Renew Energy* **29**, 569–579.
- Pozo, C., Martinez-Toledo, M.V., Rodelas, B. and Gonzalez-Lopez, J. (2002). Effects of culture conditions on the production of polyhydroxyalkanoates by *Azotobacter chroococcum* H23 in media containing a high concentration of alpechin (wastewater from olive oil mills) as primary carbon source. *J Biotechnol* **97**, 125–131.
- Putun, A.E., Burcu Uzun, B., Apaydin, E. and Putun, E. (2005). Bio-oil from olive oil industry wastes: pyrolysis of olive residue under different conditions. *Fuel Process Technol* **87**(1), 25–32.
- Ramachandran, S., Roopesh, K., Nampoothiri, K.M., Szakacs, G. and Pandey, A. (2005). Mixed substrate fermentation for the production of phytase by *Rhizopus* spp. using oilcakes as substrates. *Process Biochem* **40**, 1749–1754.
- Ramos-Cormenzana, A., Juirez-Jimenez, B. and Garcia-Pareja, M.P. (1996). Antimicrobial activity of olive mill waters (alpechin) and biotransformed mill wastewater waste-olive oil. *Int Biodeter Biodegrad* **38**(3–4), 283–290.
- Ranalli, A., Lucera, L. and Contento, S. (2003). Antioxidizing potency of phenol compounds in olive oil mill wastewater. *J Agricult Food Chem* **51**, 7636–7641.
- Rice, R.G. (1981). Ozone treatment of hazardous materials. *AIChE Symp Ser* **77**, 79–107.
- Riemer, J. and Kristoffersen, M. (1999). Information on waste management practices. A proposed electronic framework. European Environmental Agency, Copenhagen.
- Riffaldi, R., Levi-Minzi, R., Saviozzi, A., Vanni, G. and Scagnozzi, A. (1993). Effect of the disposal of sludge from olive processing on some soil characteristics, laboratory experiments. *Water Air Soil Pollut* **69**, 257–264.
- Rinaldi, M., Rana, G. and Introna, M. (2003). Olive-mill wastewater spreading in southern Italy, effects on a durum wheat crop. *Field Crops Res* **84**, 319–326.
- Rios, R.V.R.A., Martinez-Escandell, M., Molina-Sabio, M. and Rodriguez-Reinoso, F. (2006). Carbon foam prepared by pyrolysis of olive stones under steam. *Carbon* **44**(8), 1448–1454.
- Robles, A., Lucas, R., Alvarez de Cienfuegos, G. and Galvez, A. (2000). Biomass production and detoxification of wastewaters from the olive oil industry by strains of *Penicillium* isolated from wastewater disposal ponds. *Bioresource Technol* **74**, 217–221.
- Rodriguez, M.M., Perez, J., Ramos, A. and Martinez, J. (1988). Effect of extract obtained from olive oil mill on *Bacillus megaterium*. ATCC 33085. *J Appl Bacteriol* **64**, 219–222.
- Roig, A., Cayuela, M.L. and Sanchez-Monedero, M.A. (2004). The use of elemental sulphur as organic alternative to control pH during composting of olive mill wastes. *Chemosphere* **57**, 1099–1105.
- Romero, E., Benitez, E. and Nogales, R. (2005). Suitability of wastes from olive-oil industry for initial reclamation of a Pb/Zn mine tailing. *Water Air Soil Pollut* **165**, 153–165.
- Rozzi, A. and Malpei, F. (1996). Treatment and disposal of olive mill effluents. *Int Biodeterior Biodegrad* **38**, 135–144.
- Rozzi, A., Santori, M. and Spinosa, L. (1984). Anaerobic digestion in Italy with special reference to treatment of olive-oil mill wastes. In *Anaerobic digestion of sewage*

- sludge and organic agricultural wastes* (A. M. Bruce, A. Koutzell-Katsiri and P. J. Newman, eds), pp. 55–65. Elsevier Applied Science, London.
- Ruiz, J.C., de la Rubia, T., Perez, J. and Martinez Lopez, J. (2002). Effect of olive oil mill wastewater on extracellular ligninolytic enzymes produced by *Phanerochaete flavido-alba*. *FEMS Microbiol Lett* **212**, 41–45.
- Saglic, S., Ersoy, L. and Imre, S. (2002). Oil recovery from lime-treated wastewater of olive mills. *Eur J Lipid Sci Technol* **104**, 212–215.
- Saiz-Jimenez, C., Gómez-Alarcón, G., and de Leeuw, J.W. (1986). *Int. Symp. on Olive By-products Valorization*, Seville, Spain, pp. 41–60.
- Sarika, R., Kalogerakis, N. and Mantzavinos, D. (2005). Treatment of olive mill effluents. Part II. Complete removal of solids by direct flocculation with poly-electrolytes. *Environment Internat* **31**(2), 297–304.
- Saviozzi, A., Riffaldi, R., Levi-Minzi, R., Scagnozzi, A. and Vanni, G. (1993). Decomposition of vegetation-water sludge in soil. *Bioresource Technol* **44**, 223–228.
- Sayadi, S. and Ellouz, R. (1995). Roles of lignin peroxidase and manganese peroxidase from *Phanerochaete chrysosporium* in the decolorisation of olive mill waste-waters. *Appl Environ Microbiol* **61**, 1098–1103.
- Sayadi, S., Allouche, N., Jaoua, M. and Aloui, F. (2000). Detrimental effects of high molecular-mass polyphenols on olive mill wastewater biotreatment. *Process Biochem* **35**, 725–735.
- Scioli, C. and Vollaro, L. (1997). The use of *Yarrowia lipolytica* to reduce pollution in olive mill wastewaters. *Wat Res* **31**(10), 2520–2524.
- Sensoz, S., Demiral, I. and Gercel, H.F. (2006). Olive bagasse (*Olea europea* L.) pyrolysis. *Biores Technol* **97**(3), 429–436.
- Sharifian, H. and Kirk, D. (1985). Electrochemical oxidation of phenol. *J Electrochem Soc* **15**, 921–924.
- Shay, E.G. (1993). Diesel fuel from vegetable oils, status and opportunities. *Biomass Bioenergy* **4**, 227–242.
- Strub, A. (1984). The Commission of the European Communities, R&D Programme ‘Energy from biomass’. In *Thermochemical Processing Biomass* (A.V. Bridgwater, ed.), pp. 1–10. Butterworth, London.
- Sutherland, I.W. (1990). *Biotechnology of Microbial Exopolysaccharides*. Cambridge University Press, Cambridge.
- Taralas, G. and Kontominas, M.G. (2006). Pyrolysis of solid residues commencing from the olive oil food industry for potential hydrogen production. *J Analyt Appl Pyrolysis* **76**, 109–116.
- Tekin, A.R. and Dalgic, A.C. (2000). Biogas production from olive pomace. *Resources Conservation Recyc* **30**, 301–313.
- Tomati, U., Galli, E., Fiorelli, F. and Pasetti, L. (1996). Fertilisers from composting of olive-mill wastewaters. *Int Biodeter Biodegrad* **38**(3–4), 155–162.
- Topal, H., Atimtay, A.T. and Durmaz, A. (2003). Olive cake combustion in a circulating fluidised bed. *Fuel* **82**, 1049–1056.
- Toscano, G., Colarieti, M.L. and Greco, G. Jr (2003). Oxidative polymerisation of phenols by a phenol oxidase from green olives. *Enzyme Microb Technol* **33**, 47–54.

- Tsioulpas, A., Dimou, D., Iconomou, D. and Aggelis, G. (2002). Phenolic removal in olive oil mill wastewater by strains of *Pleurotus spp.* in respect to their phenol oxidase (laccase) activity. *Bioresource Technol* **84**, 251–257.
- Turano, E., Curcio, S., De Paola, M.G., Calabrò, V. and Iorio, G. (2002). An integrated centrifugation–ultrafiltration system in the treatment of olive mill wastewater. *J Membr Sci* **209**, 519–531.
- Vassilev, N., Fenice, M., Federici, F. and Azcon, R. (1997a). Olive mill waste water treatment by immobilized cells of *Aspergillus niger* and its enrichment with soluble phosphate. *Process Biochem* **32**, 617–620.
- Vassilev, N., Vassileva, M. and Azcon, R. (1997b). Rock phosphate solubilisation by *Aspergillus niger* on olive cake-based medium and its further application in soil-plant system. *Bioresource Technol* **59**, 1–4.
- Vassilev, V., Vassileva, M., Azcon, R., Fenice, M., Federici, F. and Barea J.M. (1998). Fertilizing effect of microbially treated olive mill wastewater on *Trifolium* plants. *Bioresource Technol* **66**, 133–137.
- Veglio, F., Beolchini, F. and Prisciandaro, M. (2003). Sorption of copper by olive mill residues. *Water Res* **37**, 4895–4903.
- Vitolo, S., Petarca, L. and Bresci, B. (1999). Treatment of olive oil industry wastes. *Bioresource Technol* **67**, 129–137.
- Vlyssides, A.G., Bouranis, D.L., Loizidou, M. and Karvouni, G. (1996). Study of a demonstration plant for the co-composting of olive-oil-processing wastewater and solid residue. *Bioresource Technol* **56**(2–3), 187–193.
- Vlyssides, A.G., Loizides, M. and Karlis, P.K. (2004). Integrated strategic approach for reusing olive oil extraction by-products. *J Cleaner Product* **12**, 603–611.
- Walid, K.L. (2001). Production of activated carbon from acorns and olive seeds. *Biomass Bioenergy* **20**, 57–62.
- Wang, W.G., Lyons, D.W., Clark, N.N. and Gautam, M. (2000). Emissions from nine heavy trucks fueled by diesel and biodiesel blend without engine modification. *Environ Sci Technol* **34**, 933–939.
- Williams, P.T. and Besler, S. (1993). The pyrolysis of rice husks in a thermogravimetric analyser and static batch reactor. *Fuel* **72**, 151–159.
- Yaman, S., Sahan, M., Haykiri-Acma, H., Sesen, K. and Kucukbayrak, S. (2000). Production of fuel briquettes from olive refuse and paper mill waste. *Fuel Process Technol* **68**, 23–31.
- Zabaniotou, A.A. and Karabelas, A.J. (1999). The Evritania (Greece) demonstration plant of biomass pyrolysis. *Biomass Bioenergy* **16**, 431–445.
- Zeman, L.J. and Zydney, A.L. (1996). *Microfiltration and ultrafiltration*. Marcel Dekker Incorporated, New York, USA.
- Zervakis, G., Yiatras, P. and Balis, B. (1996). Edible mushrooms from olive oil mill wastes. *Int Biodeter Biodegrad* **38**(3–4), 237–243.
- Zhang, R. and Zhang, Z. (1999). Biogasification of rice straw with an anaerobic-phased solids digester system. *Bioresource Technol* **68**, 235–245.
- Ziejewski, M., Goettle, H., Pratt, G.L. (1986). Paper No. 860301, International Congress and Exposition, Detroit, MI, 24–28 February.

Electronic sources

- http://www.oliveoilsource.com/olive_waste.htm#Orchard (accessed 2005, January, 5)
- <http://www.aegean.gr/environment/eda/naias/waste.htm> (accessed 2005, January, 15)
- <http://www.er.doe.gov/production/ober/nabir/needs.html> (accessed 2005, January, 15)
- <http://www.cpeo.org/techtree/ttdescript/ensolmx.htm> (accessed 2005, January, 15)
- <http://www.info.ngwa.org/membersonly/safety/tips/380-501.html> (accessed 2005, January, 15)
- <http://www.grc.cf.ac.uk/lrn/resources/waste/management/recovery/composting.php> (accessed 2005, January, 25)
- <http://www.compost.css.cornell.edu/Factsheets/FS1.html> (accessed 2005, January, 25)
- http://www.dublincity.ie/shaping_the_city/environment/dublin_waste_to_energy/waste_to_energy/index.asp (accessed 2005, February, 12)
- http://www.noharm.org/library/docs/Update_on_Pyrolysis.pdf (accessed 2005, February, 12)
- <http://www.ncseonline.org/NLE/CRS/abstract.cfm?NLEid=15892> (accessed 2005, February, 12)
- http://www.wasteonline.org.uk/resources/Wasteguide/mn_wmo_thermtreatment_incin.html (accessed 2005, February, 14)
- <http://www.energytek.com.tw/rk.htm> (accessed 2005, February, 21)
- <http://www.lanl.gov/orgs/d/d4/enviro/etcap/overview.html> (accessed 2005, February, 21)
- <http://www.frtr.gov/matrix2/section4/4-25.html> (accessed 2005, February, 21)
- http://www.nett21.gec.jp/JSIM_DATA/WASTE/WASTE_5/html/Doc_514.html (accessed 2005, February, 21)
- http://www.nrcan.gc.ca/es/etb/cetc/cetc01/htmldocs/factsheet_fluidised_bed_combustion_e.html (accessed 2005, February, 21)
- <http://www.ciwmb.ca.gov/Organics/Conversion/Gasification/> (accessed 2005, February, 21)
- <http://www.fao.org/DOCREP/T0512E/T0512e0a.htm> (accessed 2005, March, 2)
- <http://www.ecy.wa.gov/pubs/96414.pdf> (accessed 2005, March, 8)
- <http://www.foodsci.uoguelph.ca/dairyedu/membrane.html> (accessed 2005, March, 18)
- http://www.igb.fraunhofer.de/WWW/GF/Wasser/en/GFWM_211_MAR-Filtration.en.html (accessed 2005, March, 18)
- <http://edkme.dkme.com> (accessed 2005, April, 10)
- http://www.iconpr.com/news/news_see.cfm?inv_id=190-1 (accessed 2005, April, 18)
- <http://www.oasisenviro.co.uk/Glossary%20C%20to%20E.htm#desorption> (accessed 2005, April, 18)
- <http://www.biotank.co.uk/aerobic.htm> (accessed 2005, April, 18)
- <http://www.colebrand.com/wastad.htm> (accessed 2005, April, 20)
- http://www.europa.eu.int/comm/energy_transport/atlas/htmlu/adint.html (accessed 2005, April, 20)
- http://www.mrc.wa.gov.au/resources/anaerobic_digestion.html (accessed 2005, April, 20)
- http://www.waterspecialists.biz/html/jar_test.html (accessed 2005, April, 20)
- <http://www-ec.njit.edu/~hsieh/ene670/coagula.html> (accessed 2005, May, 5)
- <http://www.eco-web.com/cgi-local/sfc?a=/editorial/index.html&b=/editorial/06053.html> (accessed 2005, May, 5)

- <http://www.watertreatmentteam.com/electrocoagulation%20applied.htm> (accessed 2005, May, 5)
- <http://www.solaqua.com/solstilbas.html#ssback> (accessed 2005, May, 8)
- http://www.daviddarling.info/encyclopedia/S/AE_solar_distillation.html (accessed 2005, May, 8)
- <http://www.unep.or.jp/ietc/publications/techpublications/techpub-8d/desalination.asp> (accessed 2005, May, 8)
- <http://www.tifac.org.in/offer/tlbo/memb.htm> (accessed 2005, May, 8)
- <http://www.tifac.org.in/news/memb.htm> (accessed 2005, May, 8)
- http://www.woodrow.org/teachers/help/temp_presentations/kim/bioremediation.htm (accessed 2005, May, 13)
- http://www.uwm.edu/Dept/CBU/Presentations/UANL_Lecture_One.pdf (accessed 2005, August, 13)
- <http://www.epa.gov/owm/mtb/invessel.pdf> (accessed 2005, August, 13)
- http://www.scielo.br/scielo.php?pid=S0104-66322005000100005&script=sci_arttext&tlng=en (accessed 2005, August, 13)
- http://www.wasteconcern.org/Publication/rcr_composting_bangladesh_zurbrugg_2004.pdf (accessed 2005, August, 13)
- <http://www.rirdc.gov.au/reports/NPP/00-187.pdf> (accessed 2005, August, 19)
- <http://www.laggonsonline.com/reedbebs.htm> (accessed 2005, August, 19)
- http://www.esru.strath.ac.uk/EandE/Web_sites/01-02/RE_info/biomass.htm (accessed 2005, August, 19)
- <http://www.wasteresearch.co.uk/ade/efw/gassification.htm> (accessed 2005, August, 29)
- http://www.esru.strath.ac.uk/EandE/Web_sites/01-02/RE_info/biomass.htm (accessed 2005, August, 19)
- http://www.intuser.net/6/1/renew_37.php (accessed 2005, August, 29)
- <http://www.grc.nasa.gov/WWW/K-12/airplane/combst1.html> (accessed 2005, August, 29)
- <http://www.uidaho.edu/bioenergy/biodieselED/publication/01.pdf> (accessed 2005, August, 29)
- http://www.dft.gov.uk/stellent/groups/dft_roads/documents/graphic/dft_roads_024054-2.jpg (accessed 2005, August, 29)
- <http://www.home.att.net/~africantech/GhIE/ActCarbon.htm> (accessed 2005, September, 10)
- <http://www.norit.com/activatedcarbon.asp?submenuCat=introduction> (accessed 2005, September, 10)
- <http://www.dieselnets.com/standards/fuels/us.html> (accessed 2005, October, 25)
- <http://www.teknova.com/liquidcul-main.html?liquid=bacterial-liq/YT-broths/ytb1.htm> (accessed 2005, October, 12)
- <http://www.en.wikipedia.org/wiki/Flue-gas> (accessed 2006, October, 1)
- <http://www oulu.fi/resopt/wasmin/pap.pdf> (accessed 2006, October, 5)
- <http://ec.europa.eu/environment/agriculture/pdf/oliveoil.pdf> (accessed 2006, October, 12)
- <http://www.biomatnet.org/publications/1859bp.pdf> (accessed 2006, October, 12)
- <http://www.modflow.bossintl.com/html/bioremediation.html> (accessed 2006, October, 17)
- <http://www.caldo.com/pyrolysis%20&%20gasification.htm> (accessed 2006, October, 18)
- http://www.smaprms.net/DOC/Syria/009_IMOOPW.Dimashki.pdf (accessed 2006, October, 19)
- <http://www.biomatnet.org/publications/1859bp.pdf> (accessed 2006, October, 20)

Fruit/Fruit Juice Waste Management: Treatment Methods and Potential Uses of Treated Waste

Ioannis S. Arvanitoyannis and Theodoros H. Varzakas

Introduction	569
Treatment methods	570
Treatment of industrial water effluents	575
Uses of fruit wastes	578
Comparison of waste treatment methods	619
Conclusions	619

Introduction

Fruit and vegetable wastes (FVW) are produced in large quantities in markets and constitute a source of nuisance in municipal landfills because of their high biodegradability (Misi and Forster, 2002). In the central distribution market for food (meat, fish, fruit and vegetables), Mercabarna (Barcelona), the total amount of wastes coming from fruit and vegetables is around 90 tonnes per day for 250 days per year (Mata-Alvarez *et al.*, 1992). In India, FVW constitute about 5.6 million tonnes annually and currently these wastes are disposed of by dumping on the outskirts of cities (Srilatha *et al.*, 1995). In Tunisia, FVW are estimated to be 180 tons per month (Bouallagui *et al.*, 2003).

According to Verrier *et al.* (1987) and Ruynal *et al.* (1998), the total initial solid concentration of FVW is between 8 and 18%, with a total volatile solids (VS) content of about 87% when anaerobic digestion was operated. The organic fraction includes about 75% sugars and hemicellulose, 9% cellulose and 5% lignin. The easy biodegradable organic matter content of FVW (75%) with high moisture facilitates their biological treatment and shows the trend of these wastes for anaerobic digestion.

However, complex vegetable processing effluent, such as olive mill wastes containing large amounts of phenolic and non-biodegradable compounds are resistant to biological degradation (Hamdi, 1996). Aerobic processes are not favored for FVW treatment because they require preliminary treatment to minimize the organic loading rate.

The aim of this chapter is to make a comparative and critical presentation of all fruit waste treatment methods (both traditional and novel) in an attempt to disclose the most effective and low cost methods. Moreover, the aim is to observe the advantages and drawbacks of each method separately.

Treatment methods

Fruit processing industries are incriminated for a high quantity of pollution; hence, it is becoming very crucial to solve this problem by developing optimized systems for the treatment of vegetable wastes. Among the several processes that are being used nowadays, the ones described are the following: thermal processes, evaporation, membrane processes, anaerobic digestion, anaerobic co-digestion, biodiesel production, combustion, supercritical and subcritical fluid extraction, coagulation and composting.

Grape pomace de-stemming

Grape pomace as a by-product is approximately 20% of the harvested grapes (Laufenberg *et al.*, 2003) and is rich in polyphenols. Grape is the world's largest fruit crop (except for orange), with more than 61 million metric tons cultivated mainly as *Vitis vinifera* for wine production (<http://www.fao.org>). The main by-products are collected during de-stemming (stems), grape crushing and pressing (skins, seeds and lees). At present, only minimum amounts of these wastes are up-graded or recycled and this is particularly true in Europe.

The high level of polyphenols in this waste, a disadvantage for their possible use as animal feed, composting or discharge, may be turned to an advantage through the extraction of polyphenols before further utilization or treatment. In fact, many recent studies have highlighted the beneficial effects of grape or wine polyphenols for human health (Lurton, 2003). More specifically, the antioxidative properties of many natural polyphenols may exert a chemopreventive role toward cardiovascular and degenerative diseases.

Co-digestion

Co-digestion with the organic fraction of municipal solid wastes (OFMSW) has been evaluated by Fernandez *et al.* (2005) for the treatment of fats of different origin. The process of co-digestion was conducted in a pilot plant working in the semi-continuous regime in the mesophilic range (37°C) and the hydraulic retention time (HRT) was 17 days. During the start-up period the digester was fed with increasing quantities of a

simulated OFMSW (diluted dry pet food). When the designed organic loading was reached, the co-digestion process was initiated. The fat used consisted of animal fat waste from the food industry, with a similar long-chain fatty acid (LCFA) profile to that of the diluted dry pet food. Animal fat was suddenly substituted by vegetable fat (coconut oil) maintaining the organic loading. The LCFA profile for vegetable fat is completely different from that of animal fat and simulated OFMSW, short-chain-saturated LFCA being the most predominant (lauric acid, myristic acid and palmitic acid accounting for the 74% of the total LCFA content). No accumulation of LCFA or volatile fatty acids (VFA) was detected in either case. After a short adaptation period, total fat removal throughout the experiment was over 88%, whereas biogas and methane yields were very similar to those of simulated OFMSW. This proved to be an effective method and suitable technology for the treatment of waste through anaerobic co-digestion of OFMSW and fat wastes in order to obtain a renewable source of energy from biogas.

Anaerobic digestion

Anaerobic digestion technology can be competitive with aerobic systems, especially for treating industrial wastewater and organic solid wastes with high organic loading (Cavaleiro *et al.*, 2001).

The successful application of anaerobic technology to the treatment of solid wastes is critically dependent on the development and the use of high rate anaerobic bioreactors. In recent years, a number of novel reactor designs have been adapted and developed. These processes differ especially in the way microorganisms are retained in the bioreactor and the separation between the acidogenic and the methanogenic bacteria and then in reduction of the anaerobic digestion limitations (Bouallagui *et al.*, 2004).

Given the very large biodegradable organic content of FVW, a major limitation of anaerobic digestion of these wastes in a one stage system is a rapidly acidification decreasing the pH in the reactor and a larger volatile fatty acids production, which inhibits the activity of methanogenic bacteria. The two-phase systems appear as more efficient technologies for anaerobic digestion of FVW. Their greatest advantage lies in the buffering of the organic loading rate taking place in the first stage, allowing a more constant feeding rate at the methanogenic second stage.

Application of sequencing batch reactor (SBR) technology to anaerobic treatment of FVW is of interest because of its inherent operational flexibility, characterized by a high degree of process flexibility in terms of cycle time and sequence, no requirement for separate clarifiers and retention of a higher concentration of slow-growing anaerobic bacteria within the reactor. Research into the anaerobic sequencing batch reactors (ASBR) process has been carried out by several investigators with satisfactory high-solid-content waste degradation and suspended solid removal (90–93.5%).

Bouallagui *et al.* (2004) assessed the performance of a two-phase anaerobic digestion of a mixture of fruit and vegetable wastes in an ASBR. Phase separation with conventional ASBR reactors resulted in high process stability, significant biogas productivity and better effluent quality from anaerobic digestion of fruit and vegetable wastes.

Biodiesel production

Biodiesel, as an alternative fuel, has many merits. It is derived from a renewable, domestic resource, thereby relieving reliance on petroleum fuel imports. It is biodegradable and non-toxic. Compared to petroleum-based diesel, biodiesel has a more favorable combustion emission profile, such as low emissions of carbon monoxide, particulate matter and unburned hydrocarbons. Carbon dioxide produced by combustion of biodiesel can be recycled by photosynthesis, thereby minimizing the impact of biodiesel combustion on the greenhouse effect (Agarwal and Das, 2001).

Bouallagui *et al.* (2005) reviewed the potential of anaerobic digestion for material recovery and energy production from fruit and vegetable wastes (FVW) containing 8–18% total solids (TS), with a total volatile solids (VS) content of 86–92%. The organic fraction includes about 75% easy biodegradable matter (sugars and hemicellulose), 9% cellulose and 5% lignin. Anaerobic digestion of FVW was studied under different operating conditions using different types of bioreactors. It permits the conversion of 70–95% of organic matter to methane, with a volumetric organic loading rate (OLR) of 1–6.8 g volatile solids (VS)/l day. Using a two-stage system involving a thermophilic liquefaction reactor and a mesophilic anaerobic filter, over 95% volatile solids were converted to methane at a volumetric loading rate of 5.65 VS/l. The average methane production yield was about 420 l/kg added VS.

Fruits and vegetable solid wastes (FVSW) represent a potential energy resource if they can be properly and biologically converted to methane. They are renewable and their net CO₂ contribution to the atmosphere is zero. Over 60×10^6 tons of fruits and vegetables are produced annually in India, of which only 1% is processed in the fruit and vegetable processing industries.

The biochemical methane potential of 54 fruit and vegetable waste samples and eight standard biomass samples were determined by Gunaseelan (2004), in order to compare extents and rates of their conversion to methane. The ultimate methane yields (B_0) and methane production rate of fruit wastes ranged from 0.18 to 0.732 l/g volatile solids (VS) added and 0.016 to 0.122 per day, respectively, and that of vegetable wastes ranged from 0.19 to 0.4 l/g (VS) added and methane production rate ranged from 0.053 to 0.125 per day, respectively. Temperature had no effect on the B_0 of mango peels, however, the conversion kinetics was higher at 35°C than at 28°C. All the samples of fruit and vegetable wastes tested gave monophasic curves of methane production. Substantial differences were observed in the methane yields and kinetics among the varieties in mango, banana and orange. Different fruit parts within the same variety showed different yields in orange, pomegranate, grape vine and sapota. The methane yields from the mango peels of some of the varieties, orange wastes, pomegranate rotten seeds and lemon pressings were significantly ($P < 0.05$) higher than the cellulose. Methane yields and kinetics of vegetable wastes in different varieties as well as within different plant parts of the same variety differed. Onion peels exhibited yields significantly ($P < 0.05$) similar to cellulose, while the majority of the vegetable wastes exhibited yields greater than 0.3 l/g VS. Rotten tomato, onion peels, pest infested brinjal, lady's finger stalk, coriander plant wastes, cabbage leaves, cauliflower stalk, turnip leaves, radish shoots and green pea pods exhibited methane yields greater than 0.3 l/g VS added. Methane yields from

these wastes varied among different varieties and different plant parts of the same variety. In coriander plant wastes, methane yield for leaves was higher than that of structural roots.

These results provide a database on extent and rates of conversion of fruits and vegetable solid wastes that significantly contribute to the organic fraction of municipal solid wastes (OF-MSW).

Composting

Compost can act as an effective surface mulch, increase the concentration of soil organic matter, improve tilth and water holding capacity, suppress weeds and provide a long-term supply of nutrients as the organic material decomposes (Ozores-Hampton and Obreza, 1999; Evanylo and Daniels, 1999). For these reasons, composting has been advocated as one component of sustainable agriculture (Edwards *et al.*, 2000). Maintaining predictable compost quality is a particular problem when the material is produced from sources such as municipal solid waste (MSW), pulp mill solids or feedlot waste as a means of reducing an organic waste stream. In these operations, the process must be optimized for both efficiency of waste disposal and quality of end product, which demands that some compromise be made in both.

An important source of organic material for composting or soil restoration that is largely untapped is solid waste from the pulp and paper industry. Settled solids from the wastewater treatment plant of a typical pulp mill consist of expanded fibers of pulverized wood, rich in lignin and unused cellulose but low in soluble organic substances. Some nitrogen and phosphorus may be added during wastewater processing to speed decomposition.

Disposal of this material, variously referred to as clarifier solids or pulp mill sludge, presents a problem for the mill. Some of it may be incinerated, but the high water content impedes efficient combustion. Disposal by landfilling, the most common disposal method, is costly and faces increasingly stringent environmental regulations (Jackson *et al.*, 2000). Using settled solids as a soil amendment on farmland is an attractive alternative because it allows for some cost recovery, improves soil physical properties and recycles the carbon into the soil (Gagnon *et al.*, 2001).

In Flanders, the selective collection of vegetable, fruit and garden waste (VFG) has grown steadily in the past decade. During the year 2000, 375 000 Mg of VFG waste were selectively collected and composted, representing an amount of 97 kg per head in regions with selective VFG collection. It is expected that more regions will adopt the selective collection system in the near future to reduce the organic fraction of household wastes. As a result, the amount of available VFG compost keeps growing. A similar situation occurs in other EU countries. Because other sectors can absorb only limited extra quantities of this VFG compost, agriculture and horticulture are considered potential 'markets'.

Nevens and Reheul (2003) tested the possibility of applying VFG compost in a typical management of silage maize cropping in Flanders: the crop is often grown in a monoculture, with a yearly spring application of slurry and an additional application

of mineral fertilizer N. They combined an average yearly cattle slurry application (about 40 Mg/ha) and added a moderate yearly vegetable fruit and garden waste (VFG) compost application (22.5 Mg/ha). They studied the compost effect on silage maize DM yield and N uptake and determined the possible saving of additional mineral N owing to the slurry and/or compost application. They also measured the amounts of residual mineral soil N to estimate the possible threats of compost and/or slurry use for excessive nitrate leaching. Silage maize N uptake and N concentration in maize were higher when compost was applied. Despite the low N output/input rate with compost application, it did not result in an excessive amount of residual soil nitrate-N, provided that the additional mineral fertilizer N was adapted to the economic optimum level. Compared to slurry application, 4 years of VFG compost application resulted in significantly higher soil organic matter and total nitrogen concentrations.

Organic matter is converted by composting into a stable substance which can be handled, stored, transported and applied to the field without having adverse effects to the environment. Proper composting effectively destroys pathogens and weed seeds through the metabolic heat generated by the microorganisms. Such composts are not suitable as fertilizers or soil conditioners but can suppress soil-borne plant pathogens. Van-Heerden *et al.* (2002) described how citrus waste can be composted and thus converted into a value-added commodity.

Fluidized bed combustion (BFBC)

Fluidized bed combustion is a versatile technology capable of burning practically any waste combinations with low emissions. The significant advantages of the fluidized bed combustor over a conventional combustor include their compact and simple design, effective burning of wide variety of fuels, relatively uniform temperature and the ability to reduce of emissions such as SO₂ and NO_x (Armesto *et al.*, 2003). All these advantages make this a suitable technology for combustion and co-combustion of biomass.

The BFBC column used by Kaynak *et al.* (2005) was made of Inconel steel, having an inside diameter of 102 mm and a height of 900 mm. A distributor plate made of stainless steel is located at the bottom part of the column. There are one fuel feeding pipe and two overflow pipes on the column. Six ports are used for thermocouples to measure the temperature along the bed height. Chromel–alumel (Type K) thermocouples were used and located above the distributor plate. The pressure drops in the distributor and in the bed are measured with manometers. A screw feeder, a fuel hopper for fuel storage, natural gas supply, a cyclone for fly-ash removal and a manometer were involved in the experimental system.

Fruit juice industry waste is suitable for combustion. This waste is mainly the fruit stones for which the moisture content is very low and does not contain any hazardous compounds like chloride. They have calorific values similar to wood because the stones have a high lignin content. The calorific values (LHV) of apricot and peach stones are about 20 000 kJ/kg. This value is comparable with the calorific values of wood and soft coal. The total annual production of fruits having hard pits in Turkey is 1 560 000 tons in 2001 (Kaynak *et al.*, 2005). Apricot and peach production in Turkey

is higher than the other hard-pitted fruits and therefore, they have a high utilization ratio in the fruit juice industry.

Several studies have been reported on the combustion of different biomasses in a fluidized bed combustor. This technology is suggested as one of the most proper technologies for combustion and co-combustion of biomass with coal. The biomass types mainly used in the previous studies are wastes of olive oil mill, rice husk, wheat straw, wood chips, mixed sawdust, forest residue, *Salix* (willow), vegetable waste, municipal solid waste (MSW) and sludge.

Cliffe and Patumsawad (2001) experimented with the co-combustion of coal, vegetable waste, olive oil waste and MSW in a fluidized bed unit to demonstrate the technical feasibility of using these wastes as an energy source and clean combustion of MSW with a fluidized bed. They concluded that up to 20% waste from olive oil production can be co-combusted with coal with a maximum drop of efficiency of 5% in the system that is originally designed for coal combustion.

Kaynak *et al.* (2005) investigated the emissions of combustion of fruit stones (peach and apricot), which is a waste from the fruit juice industry that has not been studied in the literature before. They compared the combustion performances of peach and apricot stones with coal and determined the optimum conditions and limitations of this system for efficient combustion with reduced emissions.

The results obtained from this study can be used to propose an alternative or an additional energy source for the production of process heat in the fruit juice industries.

Ensiling

Ensiling has been used to feed lactating dairy sheep as described by Volanis *et al.* (2004). Seven tons of non-marketable ripe oranges (*Citrus sinensis*) were coarsely sliced using a modified machine meant for chopping whole plant maize and mixed with agro-industrial by-products and hay. The percentage composition of the ingredients in the ensiled orange mixture consists of orange slices, soybean meal, wheat bran, cottonseed cake, salt, calcium phosphate and oat hay. The silage was made in a trench silo approximately 1 m high, coated with a plastic sheet. After filling the silo, the mass was air-tight closed with a plastic sheet and covered with soil to secure anaerobic conditions for fermentation and to protect the silage from being exposed to solar radiation. After 30 days, the silo was opened and sampling was performed for chemical and microbiological analyses. Bulk samples were taken from two depths on a vertical section of the silage mass to obtain an indication of differences in composition between the top and bottom of the filled silo.

Treatment of industrial water effluents

Many industrial wastewater effluents, particularly from mineral processing, metal plating, electric, electronic and chemical industries, are contaminated with heavy

metals causing serious environmental problems. Currently practiced treatment methods for these effluents include flotation, coagulation/precipitation, membrane processes, electrochemical techniques and ion exchange. Precipitation followed by coagulation has been extensively employed because of its easy operation and low cost. The representative precipitation method is usually based on forming a metal hydroxide precipitate by adding some low cost alkaline materials like lime for removal of cationic heavy metals like Pb(II), Cd(II), Cu(II) and Ni(II). However, this process usually produces large volumes of sludge consisting of small amounts of heavy metals in excess gypsum, the recycling and re-use of which is very difficult. In the past few years, biosorption, bioprecipitation and uptake by biopolymers derived from agricultural wastes or microbes have appeared as emerging techniques that could provide alternative and/or additive processes for conventional physical and chemical methods for removing toxic ions from wastewater (Jamode *et al.*, 2003; Hussein *et al.*, 2005).

Large quantities of various biomass wastes are being generated in agriculture, forestry and fisheries. Some of these biomass wastes contain various natural materials with interesting functions, such as pectic acid and alginic acid. If these biomass wastes exhibit adsorption behaviors for metal ions similar to the pectic acid and alginic acid gels, it would be possible to use them successfully at a very low price, as there is no need to extract the pectic acid or alginic acid. Yano *et al.* (2001) prepared an adsorption gel of orange juice residue by cross-linking with epichlorohydrine, which also exhibited excellent adsorption behavior for Pb(II) ions similar to pectic and alginic acid gels. However, cross-linking with epichlorohydrine is also expensive and leaves various wastes after cross-linking which also require costly post-treatment. Dhakal *et al.* (2005) prepared another type of adsorption gel from orange juice residue, one of the major agricultural wastes in Japan, by a much cheaper and simpler method without using any organic cross-linking reagents, so as to avoid the problems of waste treatment after cross-linking, based on the presumption that the adsorption gel is not reused after adsorption, that is, from economical point of view it is used only once for adsorption.

Adsorption gels prepared from biomass wastes consisting of polysaccharides have another advantageous characteristic making the post-treatment much easier compared with ion exchange resins made of plastics and refractory materials, i.e. easy incineration. The metal-loaded gel can be treated as feed materials at non-ferrous metal smelters for Cu(II), Zn(II) and Ni(II) together with the metal concentrates.

The gels can also be treated in incineration plants of industrial waste where the gel is incinerated together with other metal-containing industrial wastes. After incineration, the majority of metals remain in the fly ash which can be collected by using bag filters or electric metalloaded (Dhakal *et al.*, 2005).

Membrane technologies

Membrane technology can be used in the treatment of palm oil mill effluents (POME) since the current conventional treatment system shows a lack of efficiency leading to environmental pollution issues. The conventional system, based on biological treatments of anaerobic and aerobic systems, needs proper maintenance and monitoring as the processes depend solely on microorganisms to degrade the pollutants.

Membrane separation technology undoubtedly offers a number of advantages, but its major drawbacks are membrane fouling and delayed widespread application of membrane processes in the treatment of POME. With such properties in POME, direct treatment using membranes will result in the rapid reduction of permeate flux below its theoretical capacity of the membrane which is a sign of membrane fouling. This flux decline led to an increase in the membrane cleaning cost, process down time and also membrane damage due to the frequency and harshness of cleaning condition (Maartens *et al.*, 2002).

New environmentally clean technologies

Supercritical fluid extraction and subcritical water extraction are used to isolate natural products from different raw materials, such as plants, food by-products, algae and microalgae.

Supercritical fluid extraction

When a fluid is forced to a pressure and temperature above its critical point it becomes a supercritical fluid. Thus, the supercritical state of a fluid has been defined as a state in which liquid and gas are indistinguishable from each other, or as a state in which the fluid is compressible (i.e. similar behavior to a gas) even though possessing a density similar of a liquid and, therefore, similar solvating power. Due to their low viscosity and relatively high diffusivity, supercritical fluids have better transport properties than liquids, can diffuse easily through solid materials and can therefore give faster extraction yields (Herrero *et al.*, 2006).

A preparative system on a pilot scale plant consists of a solvent pump that delivers the fluid throughout the system, a modifier pump if necessary, an extraction cell or extraction column, according to the system configuration (i.e. for solids or liquids, respectively) and one or more separators (also called fractionation cells) in which the extract is collected and the solvent depressurized.

Numerous vegetable matrices have been used as natural sources for compressed fluid extraction. Legumes, spices, aromatic plants and even fruit beverages, such as natural orange juice (Senorans *et al.*, 2001), have been processed to obtain natural antioxidant compounds.

Other interesting by-products are those from the wine industry. Their interest is related to the type and amount of phenolic compounds that are found in grape seeds and skins. Isolation of phenolic compounds from grape seeds has been attempted using supercritical carbon dioxide (Palma and Taylor, 1999; Murga *et al.*, 2000). Palma and Taylor (1999) observed that the recovery of catechin and other phenolic compounds from grape seeds was higher when using supercritical CO₂, with methanol as modifier, rather than when using traditional solid-liquid extraction. Supercritical fluid extraction is faster and allows fractionation of the phenolic compounds of the grape seeds (Murga *et al.*, 2000) by altering the pressure and adding co-solvents at different percentages. In a recent study, Louli *et al.* (2004) employed supercritical fluid extraction to increase the added value of extracts from by-products of the wine industry obtained

by extraction with ethyl acetate. These extracts had antioxidant activities similar to the synthetic antioxidant BHT.

The properties of the starting product were significantly improved by the subsequent supercritical CO₂ extraction that caused an increase in the antioxidant activity, allowing odorless and clearer extracts. These characteristics make the extracts more appropriate for use as natural antioxidants in the food industry. The selected parameters for performing the extraction were a pressure of 150 bar and a temperature of 45°C. The addition of 0.5% of co-solvent did not significantly improve the results.

The supercritical fluid extraction (SFE) of orange essential oil was studied using dehydrated orange peel (0.0538 kg H₂O/kg dm) from naveline cultivars as raw material and CO₂ as solvent. The effect of operation conditions was analyzed in a series of experiments at temperatures between 293 and 323 K and pressures between 8 and 28 MPa. The collected extracts were analyzed and the relative composition of the essential oil was determined. Limonene was the principal component extracted. The optimum conditions for limonene extraction were 12.5 MPa and 308 K, in these conditions limonene represents more than 99.5% of the essential oil (Mira *et al.*, 1999).

Subcritical water extraction (SWE)

Subcritical water extraction (SWE), i.e. extraction using hot water under pressure, has recently emerged as a useful tool to replace the traditional extraction methods. SWE is an environmentally friendly technique. The experimental device required for SWE is quite simple (Figure 9.1). Basically, the instrumentation consists of a water reservoir coupled to a high pressure pump to introduce the solvent into the system, an oven, where the extraction cell is placed and extraction takes place and a restrictor or valve to maintain the pressure. Extracts are collected in a vial placed at the end of the extraction system. In addition, the system can be equipped with a coolant device for rapid cooling of the resultant extract.

Subcritical water extraction has been widely used to extract different compounds from several vegetable matrices such as rosemary (Herrero *et al.*, 2006).

Uses of fruit wastes

Citrus fruit wastes

About 50% of the weight of citrus fruits is discarded as waste peel, membrane, juice vesicles and seeds when these fruits are squeezed (Crandall *et al.*, 1983). Obtaining by-products from these wastes may increase the economic yield of the citrus juice industries. Citrus by-products are commonly used to fortify animal fodders (Braddock, 1999), but citrus peels are also used to obtain citroflavonoids (Arriaga, 1989), aromatic components, carotenoids (Lafuente, 1980) and dietary fiber concentrates (Grigelmo-Miguel and Martin-Belloso, 1999). Thus, these wastes may be used as a source of Clouding Agents (CA) for citrus beverages.

The CA may be obtained from citrus wastes by the addition of salt after extracting the proteins (Cameron *et al.*, 1997). The CA also can be obtained with the addition of

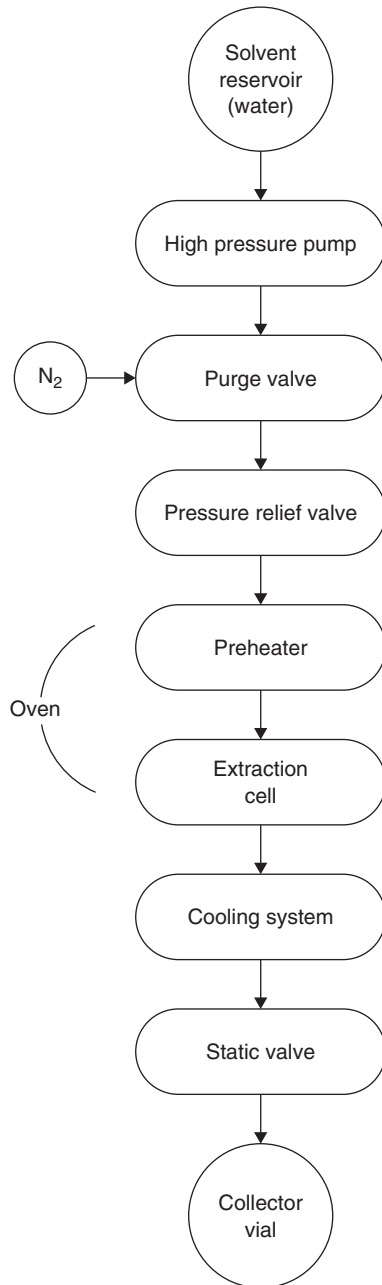

Figure 9.1 Schematic diagram of a subcritical water extraction system (adapted from Jimenez-Carmona and Luque de Castro, 1999; Herrero *et al.*, 2006; Chienthavorn and Su-in, 2006)

alcohol or by fermentation with bakers and brewers yeast (Sreenath *et al.*, 1995). These extraction processes reduced the soluble solids by almost 50% and 72% for the fermentation and alcohol extraction, respectively. Moreover, the alcohol extraction removed all the natural color of the orange peels.

Citrus junos is one of the important citrus fruits in Japan. The fruit is processed into juice as an ingredient in sauces and salad dressings for its special flavor. After juice extraction, the fruit pulp is mostly dumped as waste at large expense. The manipulation of food processing wastes has recently become a very serious environmental issue. It seemed worthwhile to seek how to make use of the waste of *C. junos* (Kato-Noguchi and Tanaka, 2004). The peel of *C. junos* fruit was found to possess potent allelopathic activity and a methanol extract of the peel inhibited the growth of several weed species (Fujihara and Shimizu, 2003).

Agricultural weed control alternatives to the present man-made herbicide-dominated programs now being considered extensively as the use of chemicals increases throughout the world. Controlling weeds through allelopathy is one strategy to reduce dependency on man-made herbicides (Duke *et al.*, 2000). Certain plant residues and extracts may function as weed-suppressive agents, therefore it is possible that *C. junos* waste could be important as a weed-suppressive residue or mulch in a field setting. The citrus fruits by-product industry utilizes the residual peels, membranes, seeds and other compounds (Braddock, 1995). Residues of citrus juice production are a source of dried pulp and molasses, fiber-pectin, cold-pressed oils, essences, d-limonene, juice pulps and pulp wash, ethanol, seed oil, pectin, limonoids and flavonoids (Ozaki *et al.*, 2000; Siliha *et al.*, 2000). The main flavonoids found in citrus species are hesperidin, narirutin, naringin and eriocitrin (Mouly *et al.*, 1994). Peel and other solid residues of lemon waste mainly contained hesperidin and eriocitrin, while the latter was predominant in liquid residues (Coll *et al.*, 1998). Citrus seeds and peels were found to possess high antioxidant activity (Bocco *et al.*, 1998).

The nutrient content of citrus by-product feedstuffs (BPF) is influenced by several factors including source of fruit and type of processing. Citrus are important components of ruminant feeding systems in many areas of the world and are commonly used as sources of dietary energy. The main citrus BPF fed to ruminants are fresh citrus pulp, citrus silage, dried citrus pulp, citrus meal and fines, citrus molasses, citrus peel liquor and citrus activated sludge. Other minor BPF include cull or excess fruit. Citrus silage and pulp are generally very rapidly accepted by most classes of ruminants. Citrus BPF have similar digestibility among ruminant species. They contain a variety of energy substrates for ruminal microbes, including both soluble carbohydrates and rapidly digested neutral detergent fiber (NDF) (Bampidis and Robinson, 2006).

The main citrus by-products produced from citrus processing include citrus pulp, the whole residue after extraction of juice consisting of a mixture of peels, inside portions, seeds and culled fruit which represent approximately 50–65% of the whole fruit by weight depending on the variety of fruit, the processing methods used and the influence of environmental factors (Grasser *et al.*, 1995), dried citrus pulp (formed by shedding, liming, pressing and drying the peel, pulp and seed residues), citrus molasses made by concentrating the press liquor from the citrus peel residue, citrus peel liquor, which is similar to citrus molasses, but not as concentrated, and citrus activated sludge which is produced from liquid wastes from citrus processing plants (Figure 9.2).

Solar dried citrus pulp (SDCP), dried by solar energy, can be incorporated into concentrate mixtures for fattening lambs at levels equal to 30% without adverse effects

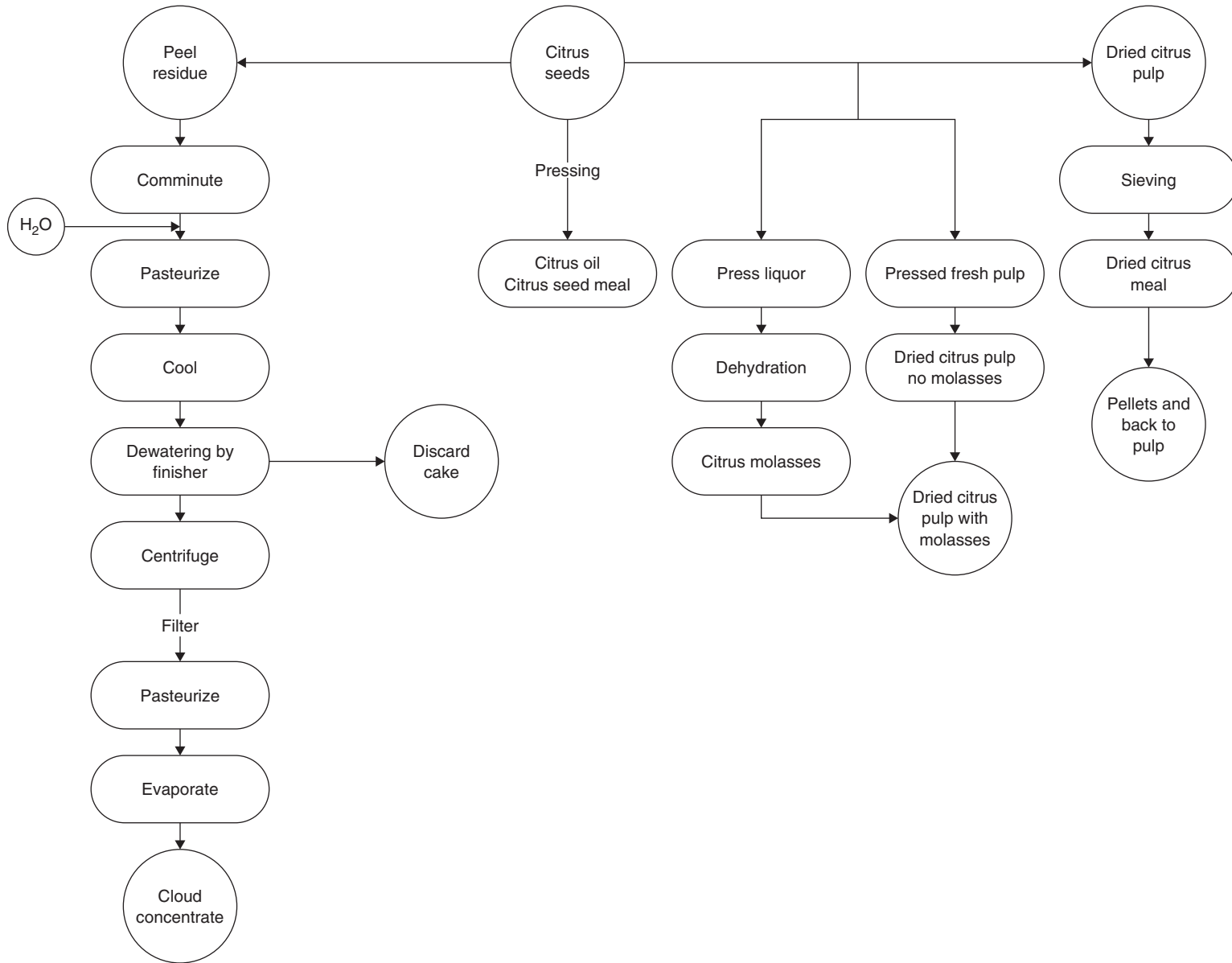

Figure 9.2 Schematic presentation of citrus by-product production (adapted from Sinclair, 1984; Braddock, 1999; Bampidis and Robinson, 2006)

both in growth and slaughter performances as well as in carcass and meat quality and could prove an economically convenient solution (Caparra *et al.*, 2006).

Citrus pulp can be used in animal feeding either fresh or after ensilage or dehydration (Caparra *et al.*, 2006).

The dried form of citrus pulp, despite the considerable advantages, is not economically viable owing to the high costs of artificial dehydration, yet, the exploitation of solar energy for citrus pulp drying, practiced in California and occasionally in Sicily and Calabria, is a potentially valid alternative to the use of fossil fuels in rural areas with a Mediterranean climate.

Citrus juice centrifugation pulp is the semisolid product obtained from the industrial centrifugation of juices, to obtain a clear juice. It is mainly composed of endocarp residual membranes, vesicles and, to some extent, of albedo and esocarp. It is also rich in sugars, fibers and other residual substances. This waste is responsible for many economic and environmental problems because of its fermentability. Furthermore, because of its high water content (about 86%), it is difficult to dry in common industrial drying devices (Tripodo *et al.*, 2004).

The flow chart in Figure 9.3 shows the mechanism for using the pulp from centrifuged juice for the production of animal feed. A liquid is obtained as a by-product of the pulp pressing which, after concentration in three sequential evaporators, can be recycled back through the pressing sequence again alongside a new batch of treated pulp. About one-third less heat is required to evaporate off the water from the filtrate obtained during pressing with the use of these three evaporators. When the concentrated liquid is reintroduced into the production cycle, it enriches the treated pulp with soluble substances and so further enhances the nutritional value of the final product. The steam produced during the concentration process could be used as a recyclable energy source. Finally, in addition to the clear environmental benefits to be gained from the recycling of the pulp from centrifuged orange and lemon juice, the citrus processing industry might also receive a technological and economic boost from the introduction of these new production cycles to work alongside their traditional ones (Tripodo *et al.*, 2004).

Moreover, citrus fruits have better quality than other sources of dietary fibers due to the presence of associated bioactive compounds (flavonoids and vitamin C) with antioxidant properties. Lemon possesses the highest antioxidant potential among citrus fruits and it is the most suitable fiber for dietary prevention of cardiovascular and other diseases (Gorinstein *et al.*, 2001). In Figure 9.4, a flow chart of lemon juice by-products processing is presented where the main by-products are raw lemon residue, dried lemon fiber, washed and dried lemon fiber and raw washed lemon fiber.

Among the processes developed to obtain high dietary fiber products, the following treatments have been performed to improve the functionality of insoluble fiber, which is the main component of some commercialized products:

- 1 partial delignification of lignocellulose by alkaline hydrogen peroxide treatment
- 2 extrusion
- 3 encapsulation with soluble fiber to produce a product with better textural properties
- 4 enzymic modification to improve sensory properties (Larrauri, 1999).

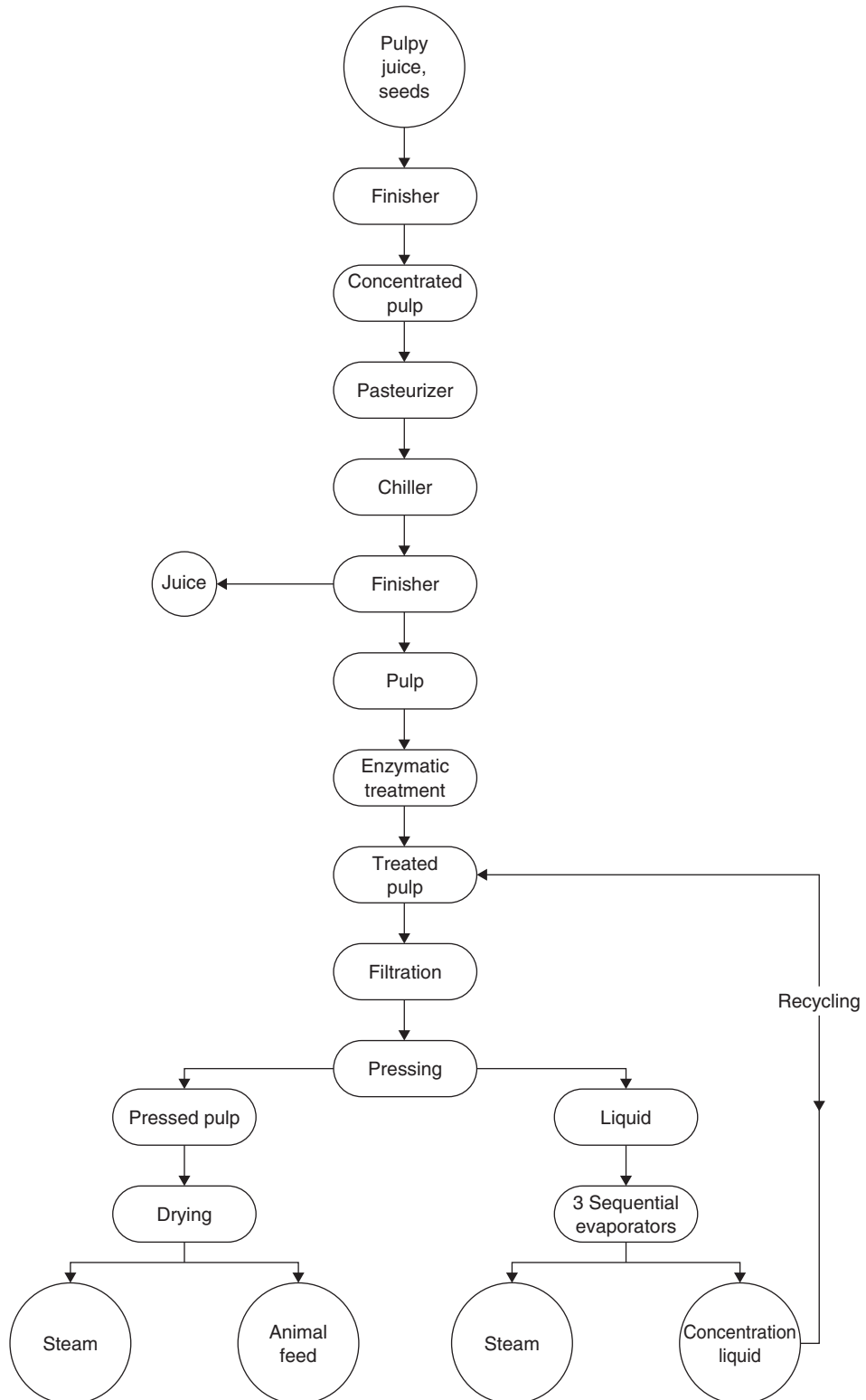

Figure 9.3 Scheme of a possible industrial processing cycle for pulp (adapted from Braddock, 1999; Tripodo *et al.*, 2004)

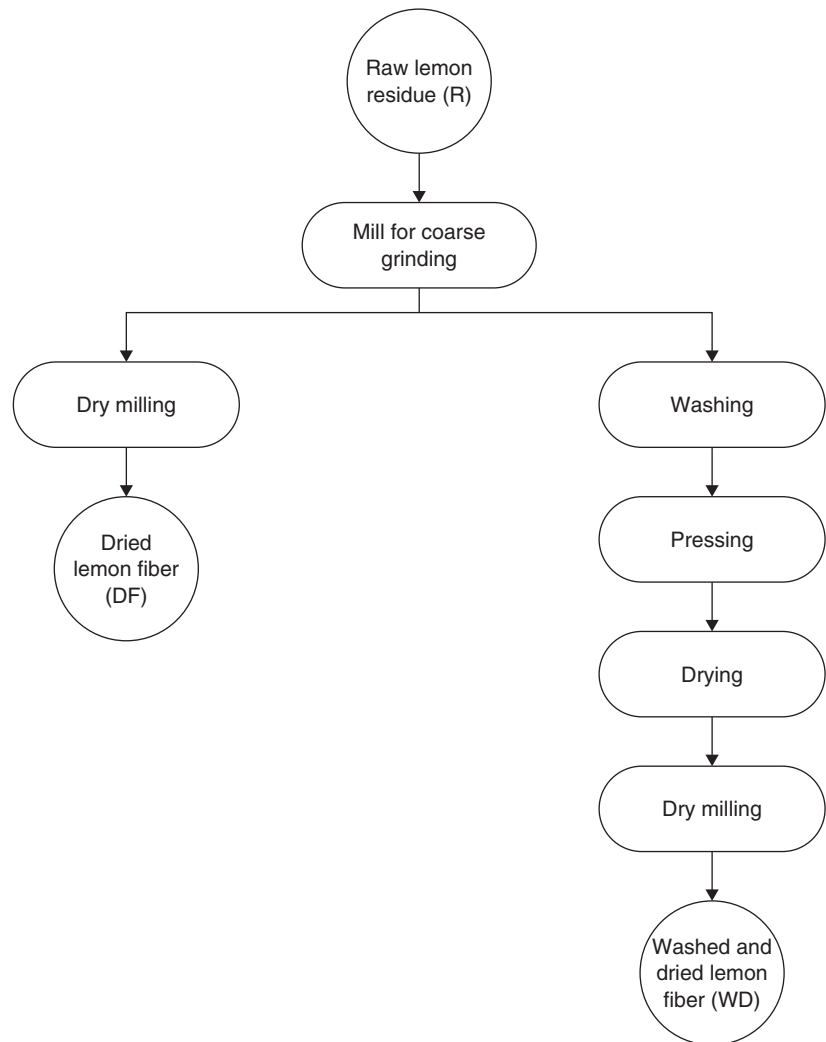

Figure 9.4 Flow chart of juice by-products processing (adapted from Lario *et al.*, 2004)

The main technological steps involved in the preparation of dietary fibers are wet milling, washing, drying and dry milling.

Wet milling Hammer mills with a variety of screen sizes are preferred to colloidal mills in order to obtain a good control of particle size. Different particle sizes in the milling of fresh raw material (0.6 to 2.0 cm) have been used (Larrauri, 1999).

Washing Selective removal of the undesirable compounds associated with dietary fiber and the removal of potentially pathogenic microorganisms are the main objectives of this operation.

Drying Water removal of the washed material is necessary prior to drying by means of screening, pressing, pulping or other processes. Continuous devices such as a helical

press or pulping machine are preferred to batch equipment such as the hydraulic press. Drying is the main and most expensive step in dietary fiber production. It improves the fiber shelf-life without the addition of any chemical preservative and reduces both the size of package and the transport costs. Different drying methods are used in the food industry: tunnel belt, rotatory kiln, drum dryer, etc.

Dry milling Most fibers are milled to improve acceptability in the final food products and the fractions obtained can have a different chemical composition, depending on the origin and history of the cell wall material. Grinding may affect hydration characteristics of the fibers as well as texture, aspect and the quality of the food to be added, depending on their chemical composition and physical structure.

Recently, lemon albedo and orange dietary fiber powder were investigated as functional compounds in cooked and dry-cured sausages (Fernandez-Lopez *et al.*, 2004), carotenoid pigments were recovered from red grapefruit juice (Lee, 2000) and a debittering process was developed to convert bitter and unpalatable citrus peel juice and molasses into an acceptable product for food use (Grohmann *et al.*, 1999).

Finally, volatile extracts of orange peel (*C. sinensis* and *C. aurantifolia*) have been reported to possess insecticidal potency on mosquitoes, cockroaches and houseflies (Ezeonu *et al.*, 2001).

Jeong *et al.* (2004) reported that heat treatment at 150°C for 40 min liberated bound phenolics in citrus peels, as a result of which the total phenolic content increased significantly from 71.8 to 171.0 μM after treatment.

Narirutin and hesperidin are the predominant flavanone glycosides found in *Citrus unshiu* peels (Kim *et al.*, 2007). Narirutin is known to exhibit oviposition-stimulatory activity and has also been demonstrated to exhibit antioxidative activity equal in strength to that of butylated hydroxyanisole (BHA). Kim *et al.* (2007) used a non-ionic acrylic ester polymer resin, Amberlite XAD-7, with the highest levels of adsorption efficiency to flavonoids and low adsorption level to sugars and pigments, to develop a simple and efficient process for the recovery of narirutin from a water-extract of *C. unshiu* peels.

Pérez-Marín *et al.* (2007) explored the feasibility of using orange residues arising from the orange-juice and soft-drinks industries wastes as an adsorbent for the removal of cadmium. Orange waste contains cellulose, pectins, hemicellulose, chlorophyll pigments and other low molecular weight compounds, including limonene.

Citric acid substrates

Different agro-industrial residues such as apple pomace, pineapple waste, mixed fruit, banana and kiwi fruit peel have been investigated for their potential use as citric acid substrates (Hang and Woodams, 1985; Shojaosadati and Babaripour, 2002; Kumar *et al.*, 2003a) as reported in the review by Rodriguez-Couto and Sanromán (2006). Moreover, waste *Aspergillus niger* mycelia from a citric acid production plant were used as a source of chitosan. The extraction of chitosan was operated with lysozyme, snailase, neutral protease and novel chitin deacetylase from *Scopulariopsis brevicaulis* at the optimum condition of every enzyme. Chitosan is soluble in acid solutions and has a wide range of uses in the cosmetic, pharmaceutical, agricultural and food industries. In the food industry it can be used for clarification of juices.

Dye removal

Activated carbon is the most employed adsorbent for dye removal from aqueous solution because of its excellent adsorption properties. However, it is very expensive to use limiting its large-scale application in wastewater treatment. Alternative low cost adsorbents for dye removal from aqueous solution are the following: apple pomace (Robinson *et al.*, 2002), orange peel (Sivaraj *et al.*, 2001; Forgacs *et al.*, 2004) and banana pitch (Forgacs *et al.*, 2004).

Passiflora edulis, *F. flavicarpa*, commonly known as the yellow passion fruit, is cultivated on a large scale in Brazil and is of agronomic importance because its fruits are used in nature and in the juice industry. Mandarins (*Citrus reticulata*) are cultivated and well adapted in several countries, mainly in those where a high temperature predominates in summer, followed by a mild one in winter. This fruit is very commonly cultivated in Brazil and is consumed in nature and also used in the juice industry. As the yellow passion fruit (PFP) and mandarin (MP) peels are very abundant in Brazil, there is a need to find a use for these by-products of industrial activities. Hence, PFP and MP wastes can be used as a biosorbent for successful removal of methylene blue from aqueous samples.

Toxic heavy metals removal

Waste residues obtained from the juice processing industry were used as biosorbents for the removal of toxic heavy metals from wastewaters (Senthilkumaar *et al.*, 2000). The cation exchange properties of these residues may be attributed to the presence of carboxylic and phenolic functional groups, which exist either in the cellulosic matrix or in the materials associated with cellulose such as hemicellulose and lignin.

Conventional methods for heavy metal removal from wastewater include reduction, precipitation, ion exchange, filtration, electrochemical treatment, membrane technology and evaporation removal, all of which may be ineffective or extremely expensive when the metals are dissolved in large volumes of solution at relatively low concentrations. Hence, there is great interest regarding the removal of cadmium from wastewater streams. For example, some of the non-conventional low cost adsorbents recently used for the removal of heavy metals are apple residues (Lee *et al.*, 1998), banana pith and mandarin peels (Pavan *et al.*, 2006).

The removal of toxic metals from wastewaters is an issue of great interest in the field of water pollution, which is one of the most crucial worldwide environmental problems (Arvanitoyannis and Kassaveti, 2007). Veglio *et al.* (2003) investigated the potential use of solid olive mill residues as a copper-biosorbing material. This waste, after having been dried in an atmospheric environment for a year, was ground and sieved. The solid olive mill residues were found to be an appealing 'low-cost' biosorbing material and promising copper sorbents, which can be effectively used for the treatment of metal-bearing effluents.

Fruit processing by-products

Apple pomace

Production of pectin is considered the most reasonable way of utilizing apple pomace, both from an economical and from an ecological point of view (Endreß, 2000). In

comparison to citrus pectins, apple pectins are characterized by superior gelling properties. However, the slightly brown hue of apple pectins caused by enzymatic browning may lead to limitations to their use in very light-colored foods (Schieber *et al.*, 2001).

Apple pomace has been shown to be a good source of polyphenols which are predominantly localized in the peels and are extracted into the juice to a minor extent. Major compounds isolated and identified include catechins, hydroxycinnamates, phloretin glycosides, quercetin glycosides and procyanidins (Foo and Lu, 1999; Lommen *et al.*, 2000; Schieber *et al.*, 2001).

Enhanced release of phenolics by enzymatic liquefaction with pectinases and cellulases represents an alternative approach to utilizing apple pomace, but does not allow the recovery of pectin.

Plant seeds can be good sources for β -glucosidase with higher glucose endurance. Annually, the yields of various fruits are very high, for example the world yield of apple was 56.2 million metric tons in 2002 and 20% of that was used for the production of juice, which means large amounts of wastes, including seed and pomace, were produced at the same time (Tian, 2004).

Apple pomace can be used as flavor extract and for fermentation, while almond shell can be used for wastewater treatment and metal/organic waste adsorption. If these fruit wastes can be taken as the enzyme sources, not only can the waste be value added, but the price of the catalyst can also be reduced greatly. Fruit seeds were screened as a source of glucosidase and, consequently, apple seed and peach meal were finally chosen as excellent glucosidase sources due to their higher activity, broader substrate spectrum and better stability (Yu *et al.*, 2006).

Grape pomace

Grape pomace represents approximately 20% of the weight of grapes processed. Hence, grape pomace amounts to more than 9 million tons per annum since more than 60 million tons of grapes are produced annually. Its composition varies considerably, depending on grape variety and the technology of wine making.

A great range of products such as ethanol, tartrates, citric acid, grape seed oil, hydrocolloids and dietary fiber are recovered from grape pomace (Hang, 1988; Bravo and Saura-Calixto, 1998; Nurgel and Canbas, 1998; Girdhar and Satyanarayana, 2000). Anthocyanins, catechins, flavonol glycosides, phenolic acids and alcohols and stilbenes are the principal phenolic constituents of grape pomace. Anthocyanins have been considered the most valuable components. In Chardonnay grape pomace, 17 polyphenolic constituents were identified by NMR spectroscopy (Lu and Foo, 1999). Catechin, epicatechin, epicatechin gallate and epigallocatechin were the major constitutive units of grape skin tannins (Souquet *et al.*, 1996). A new class of compounds, aminoethylthio-flavan-3-ol conjugates, has been obtained from grape pomace by thiolysis of polymeric proanthocyanidins in the presence of cysteamine (Torres and Bobet, 2001). Recovery of phenolics from grape pomace is very important due to the inhibitory effects to low-density lipoproteins.

Much research was carried out on the polyphenols derived from grape marc. Saura-Calixto (1998) and Loo and Foo (1999) carried out research on grape seeds and grape

pomace peels. Bonilla *et al.* (1999) explored the possibilities of using phenolic compounds from grape marc as food lipid antioxidants. Louli *et al.* (2004) investigated the effect of various process parameters – solvent type and feed pretreatment (crushing, removal of stems) – on the extraction efficiency of phenolic antioxidants from grape marc, whereas Negro *et al.* (2003) investigated the content of total polyphenols and antioxidant activity of grape marc extracts.

In Slovenia, grapes are abundant and are used in wine making. After fermentation (maceration) and pressing, seeds and skins remain as marc, which still contain some anthocyanins and polyphenols. There are also some plantations, where red- and blackcurrants are produced. Their crop is usually made into juices, but skins, which remain after pressing, still contain a lot of anthocyanins and other phenol compounds. Lapornik *et al.* (2005) compared different extracts from grape marc, which had been examined in many other studies described above, with redcurrant and blackcurrant marc which are also rich sources of antioxidant components. Blackcurrant and redcurrant marc are especially rich on anthocyanins, so extracts made from them could be used as natural colorants.

Peach and apricot

Bitter apricot (*Prunus armeniaca* L., Rosaceae) stones are by-products of the apricot processing industry. Peeled stones can be used in the production of persipan. This requires debittering by hydrolysis of amygdalin. Moreover, apricot stone oil can be used in cosmetics. Pomace of wild apricot proved to be a rich source of proteins but also contained low levels of amygdalin.

Besides apricot stones, peach (*Prunus persica* L. BATSCH, Rosaceae) stones may also be used for the production of persipan. Recently, the recovery of pectin from fresh peach pomace has been described (Pagan and Ibarz, 1999). Quality evaluation revealed that peach pectin is highly methoxylated and has favorable gelling properties.

Mango

Mango seed kernel fat is a promising source of edible oil and has attracted attention since its fatty acid and triglyceride profile is similar to that of cocoa butter. Mango seed kernels may also be used as a source of natural antioxidants. The antioxidant principles were characterized as phenolic compounds and phospholipids (Puravankara *et al.*, 2000). The phenolics were assumed to be mainly gallic and ellagic acids and gallates. In another study, gallotannins and condensed tannin-related polyphenols were reported in mango kernels (Arogba, 2000).

Pineapple

In 1997, 12.8×10^6 tons of pineapples (*Ananas comosus* L. MERR., Bromeliaceae) were produced worldwide (Schieber *et al.*, 2001). The pulpy waste materials resulting from juice production still contain substantial amounts of sucrose, starch and hemicellulose and may therefore be used for ethanol production (Tanaka *et al.*, 1999; Nigam, 2000) apart from their potential antioxidant applications.

Correia *et al.* (2004) described the use of the fungus *Rhizopus oligosporus* to produce phenolic compounds from a pineapple waste (residual pulp, peels and skin)-soybean flour mixture. These authors found a twofold increase in total phenolics content of a 1:1 pineapple:soybean flour mixture 12 days after incubation with the fungus.

Banana

Banana (*Musa x paradisiaca* L., Musaceae) represents one of the most important fruit crops, with a global annual production of more than 50 million tons. Peels constitute up to 30% of the ripe fruit. About 1000 banana plants are estimated to yield 20–25 tons of pseudostems providing about 5% edible starch (Anand and Maini, 1997). Attempts at utilization of banana waste include the biotechnological production of protein (Chung and Meyers, 1979), ethanol (Tewari *et al.*, 1986), α -amylase (Krishna and Chandrasekaran, 1996), hemicellulases (Medeiros *et al.*, 2000) and cellulases (Krishna, 1999). Very recently, anthocyanin pigments in banana bracts were evaluated for their potential application as natural food colorants and were found to be a good source of anthocyanins (Pazmino-Duran *et al.*, 2001). Most of the carotenoids found in banana peels were demonstrated to be xanthophylls.

Guava

Guava (*Psidium guajava* L., Myrtaceae) is a rich source of relatively low methoxylated pectins (50%). Since wastes constitute only 10–15% of the fruit, the use of guava for pectin production is limited. The seeds, usually discarded during processing of juice and pulp, contain about 5–13% oil rich in essential fatty acids.

Recent investigations indicated that peel and pulp of guava fruits could be effectively used as a source of antioxidant dietary fiber (Jimenez-Escrig *et al.*, 2001).

Papaya

Papain, a proteolytic enzyme used as a meat tenderizer and as a stabilizing agent in the brewing industry, is recovered from the latex of papaya fruit (*Carica papaya* L., Caricaceae). Furthermore, papaya fruits may also be used for the production of pectin. The seeds are sometimes used as a substitute and even as an adulterant for pepper due to their spicy flavor which is caused by glucosinolate degradation. The seed oil is low in polyunsaturated fatty acids, but defatted papaya seed meal contains high amounts of crude protein (40%) and crude fiber (50%) (Jagtiani *et al.*, 1988).

Passion fruit

The waste resulting from passion fruit (*Passiflora edulis* SIMS, Passifloraceae) processing consists of more than 75% of the raw material. The rind constitutes 90% of the waste and is a source of pectin (20% of the dry weight). Passion fruit seed oil is rich in linoleic acid (65%) (Askar and Treptow, 1998).

Kiwifruit

Kiwifruit (*Actinidia chinensis* PLANCH., Actinidiaceae) waste results from rejected kiwifruits, which comprise up to 30% of the total kiwifruit crop, and from kiwifruit

pomace after juice production. A comprehensive review of the components and potential uses of kiwifruit waste was compiled by Kennedy *et al.* (1999).

Cranberry

Approximately 420 million pounds (190 million kg) of cranberries are produced annually in the USA, about 90% of which are used for processing purposes. The primary by-product of traditional cranberry juice processing is cranberry pomace. It consists of the processed skins, seeds and stems and constitutes about 5% of the wet weight of the original fruit. Freshly pressed cranberry pomace contains a large amount of insoluble carbohydrates with small amounts of protein, minerals and some remaining juice with sugars and other soluble substances. Freshly pressed cranberry pomace is susceptible to rapid microbial growth due to its high moisture content. Cranberry processing waste is commonly used as animal feed or fertilizer. However, its value as animal feed is very limited because of its low protein content and its use as fertilizer may not be economically competitive. Further, direct disposal of pomace waste to soil or in a landfill poses significant environmental problems. Utilization of cranberry processing waste has been described by Zheng and Shetty (1998).

Watermelon

Citrulline is a non-essential amino acid first identified from the juice of watermelon, *Citrullus vulgaris* Schrad. and later obtained from tryptic digestion of casein. Citrulline has been isolated in other cucurbitaceous fruits including bitter melon, cucumber, muskmelon, pumpkin, bottle gourd, dishrag gourd and wax gourd (Inukai *et al.*, 1966). Citrulline is used in the nitric oxide system in humans and has potential antioxidant and vasodilatation roles (Rimando and Perkins-Veazie, 2005). From this study, it is apparent that the rind contains citrulline in high quantities. Rimando and Perkins-Veazie (2005) showed that the watermelon rind is a rich source of citrulline and may yield a useful product from an agricultural waste. L-Citrulline given orally to children and adolescents with sickle cell disease resulted in improvement of symptoms, raised plasma arginine levels and reduced elevated total leukocyte and segmented neutrophil counts to within normal limits.

Half of a watermelon fruit is edible while the other half, consisting of about 35% rind and 15% peel, goes to waste (US Department of Agriculture, 2004).

Sugar beet by-products

Figure 9.5 shows the inputs and outputs in a combined sugar factory/distillery (or any other biotechnological industry). The molasses produced by the sugar factory are utilized in the production of ethyl alcohol by biotechnological means. Traditional sugar technology from the environmental point of view suffers from the calco-carbonic purification process. The amounts of lime utilized (Figure 9.6) are very important and stand for a huge environmental problem since they arise from mines. An enormous amount of sludge is also produced which proves difficult to dispose of. As far as sugar cane processing is concerned, bagasse (higher content of cellulose and lignin and no pectins

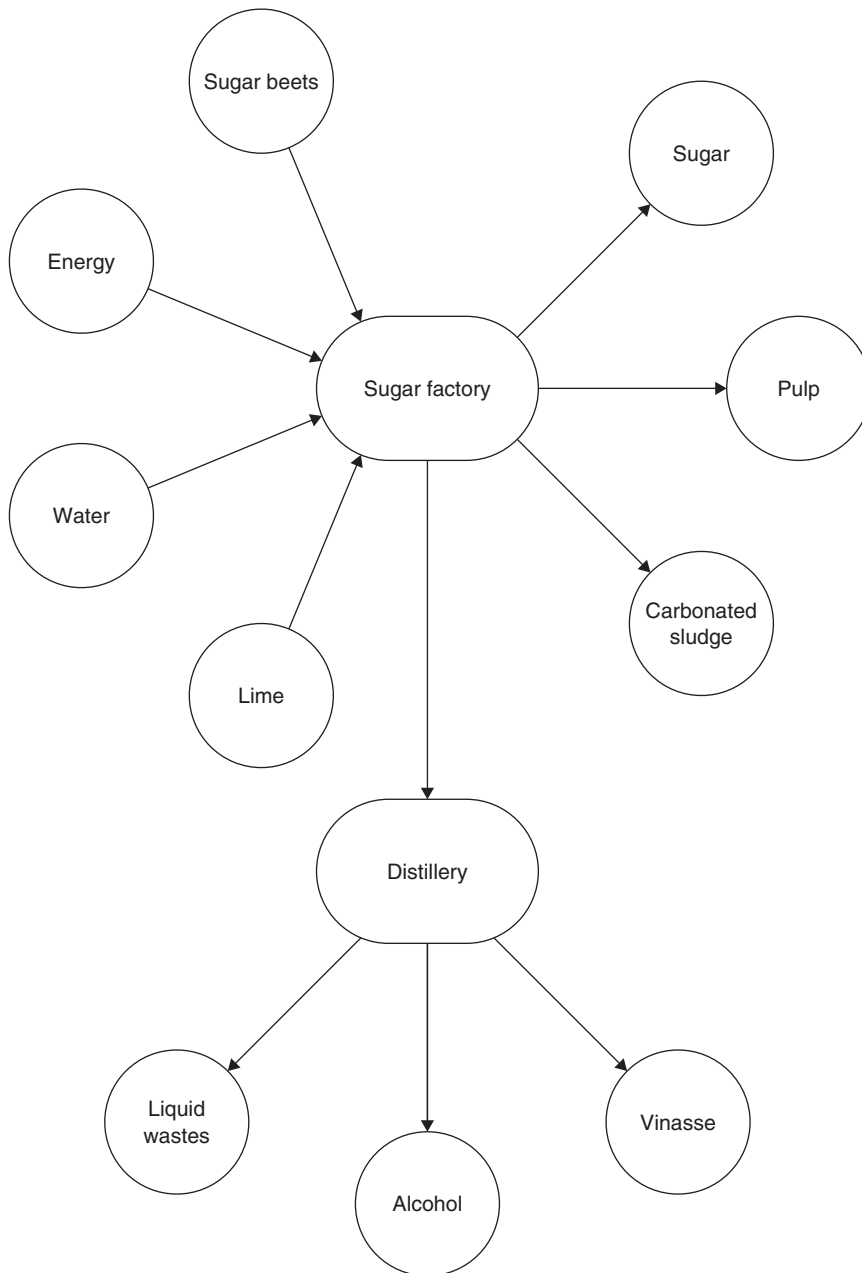

Figure 9.5 Streams which enter and leave a combined sugar factory/distillery (Kotzamanidis *et al.*, 2000; Vaccari *et al.*, 2005)

compared to beet pulp) represents a great value by-product, which can be used either for the production of power or for obtaining paper or other composite materials.

Beet pulp could be used as 'organic filler' in the production of paper with or without sludges. Vaccari *et al.* (2005) suggested a way to prepare paper from beet pulp, either dried pulp (90% dry substance) or overpressed pulp (25% dry matter). Two cases

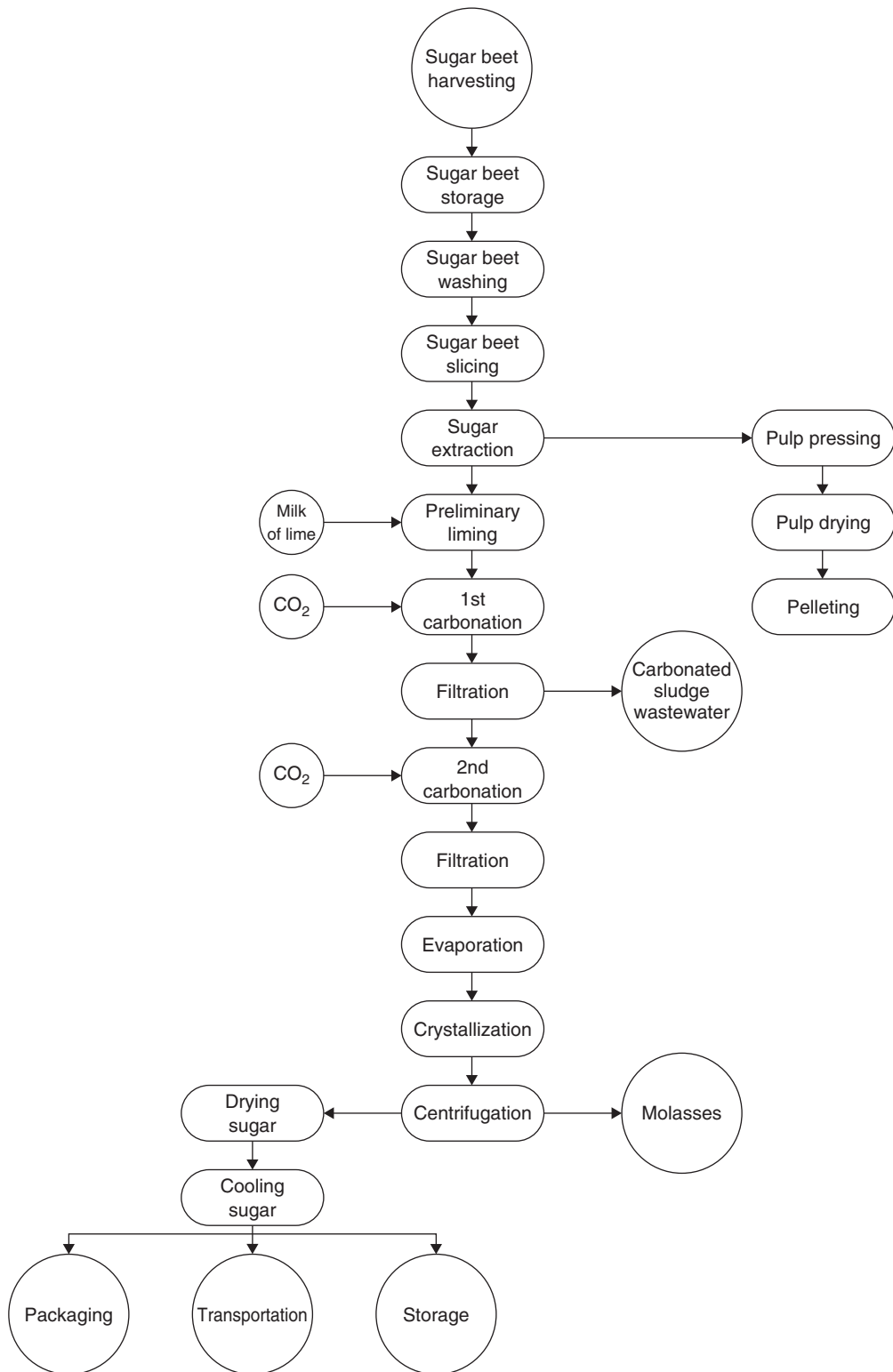

Figure 9.6 Simplified Frow diagram of a sugar production factory (Kotzamanidis *et al.*, 2000; Vaccari *et al.*, 2005)

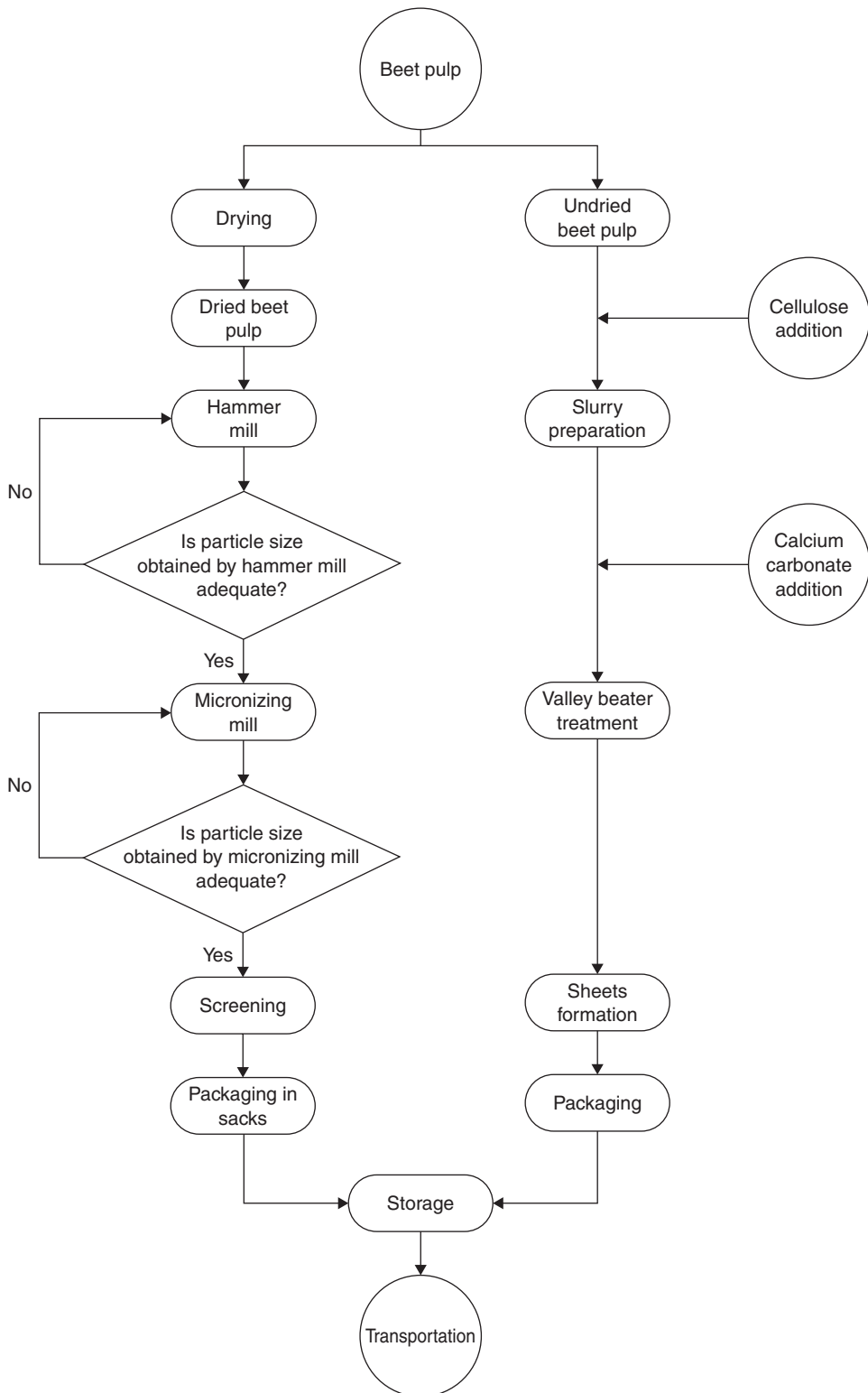

Figure 9.7 Pretreatment adopted for the utilization of dried and undried beet pulp for paper production (adapted from Vaccari *et al.*, 2005)

exist: the 'dry pulp' must be 'dry' ground and/or micronized, while the 'overpressed pulp' must be mixed with cellulose forming a slurry which is then 'wet' ground (Figure 9.7).

Carbonation sludge could be used in paper production if previously dried and micronized.

The disposal of the organic fraction of the urban solid wastes (OFUSW) has caused many concerns. With regard to the vinasse produced by the distilleries, the problem escalates if the alcohol obtained via fermentation is to be utilized in large amounts as a fuel (e.g. Brazil). According to Viccari *et al.* (2005) a medium size distillery processing 110 000–120 000 t molasses per year produces about 70 000 t of concentrated (60 Brix) vinasse/year. Its utilization as a fodder does not solve the problem. A possible solution for both the problems concerning OFUSW and vinasse could be the production of good quality 'compost' to be used as fertilizer. According to Viccari *et al.* (2005), it is possible to mix, in stages, vinasse and OFUSW and submit the mixture to a fermentation-controlled process for the production of compost. Experimental trials using an OFUSW/vinasse ratio of 3:1 gave good results.

A solution to the problem of lime utilization can only be reached by the total elimination of the traditional calco-carbonic purification process, thus reducing the carbon dioxide and ammonia emissions which occur during this process. The calco-carbonic purification process eliminates part of the non-sugar compounds (in particular the thermolabile ones), makes the solution alkaline thereby decreasing the risk of sucrose inversion and gives limp and relatively not very colored juices. Such solutions are the following:

- 1 Commercial white sugar production from raw juice if the latter is previously microfiltered, Mg removed by ion exchange resins, concentrated at low temperature and crystallized by cooling in subsequent steps. The sugar obtained from the first step is commercial white sugar, while the sugar obtained from the following steps must be recycled. Microfiltration can be carried out using organic or ceramic membranes. The elimination of magnesium originating from beet is necessary to avoid its co-crystallization with sucrose.
- 2 Raw juice, after microfiltration and softening, can be chromatographically separated using simulated moving bed (SMB) plants. The sugar-rich fraction can be concentrated at low temperature and crystallized by cooling in several steps. Commercial white sugar is obtained from the first two steps and sugar to be recycled from the following steps, before obtaining the final molasses.
- 3 Combination of the two previous technologies.

Finally, phenolics can be produced from agro-industrial by-products by the sequential treatments of dewaxed sugarcane bagasse with water, alkali and alkaline peroxide which resulted in esterified ferulic and coumaric acids (Sun *et al.*, 2003).

Hawthorn (*Crataegus pubescens*)

Crataegus pubescens known as *Crataegus stipulosa*, *Crataegus succulenta* and *Crataegus mexicana*, is a member of the Rosaceae family and is one of the approximately 200 species of hawthorns genus *Crataegus*, which has its origin in China and Mexico (Borys, 1996). It is cultivated in Asia, Australia, Canada, Mexico, Central

Table 9.1 Treatment methodologies of fruit wastewaters: parameters, quality control methods and results

No	Kind of waste	Treatment	Parameters	Methodology	Quality control methods	Results	References
1	Orange peel	Use of polygalacturonase (PG) and cellulase (C) to hydrolyze most of the peel components	Treatment temperature (T), treatment time (t) and concentration of each enzyme	Treatment of orange peels (heating and enzymatic treatment)	Turbidity determination of cloud stability using a turbidimeter, color measurement, extraction yield measurement of clouding agents	<p>1 The use of PG and C to produce a CA from orange peels with high cloud stability is feasible</p> <p>2 CA provided the greatest cloud stability when the process was carried out at 45°C during 80 min with the addition of 90 µl/kg of PG and 69 mg/kg of C</p> <p>3 However, these conditions did not produce the highest extraction yield</p>	Espachs-Barroso <i>et al.</i> , 2005
2	<i>Citrus junos</i> fruit waste	The fruit waste of <i>C. junos</i> after juice extraction was freeze-dried and divided into peel, inside and seeds. Extraction followed	The concentrations of abscisic acid-b-D-glucopyranosyl ester (ABA-GE)	Six species, alfalfa (<i>Medicago sativa</i> L.), cress (<i>Lepidium sativum</i> L.), crabgrass (<i>Digitaria sanguinalis</i> L.), lettuce (<i>Lactuca sativa</i> L.), timothy (<i>Pheleum pratense</i> L.), and ryegrass (<i>Lolium multiflorum</i> Lam.) were chosen for bioassay as test plants	The concentrations of abscisic acid-b-D-glucopyranosyl ester (ABA-GE) in peel, inside and seeds separated from the <i>C. junos</i> fruit waste were determined, since ABA-GE was found to be one of the main growth inhibitors in <i>C. junos</i> fruit. Purification of the extract using ion exchange columns. HPLC determination of ABA-GE	The concentration was greatest in the peel, followed by the inside and seeds; there was a good correspondence between these concentrations and the inhibitory activities of the extracts. <i>C. junos</i> waste may possess allelopathic potential and the waste may be potentially useful for weed management	Kato-Noguchi and Tanaka, 2004
3	Grape pomace extracts	De-stemming	The methanolic extracts (MeOH) obtained from de-stemmed grape pomace samples	Study of the main polyphenol constituents and the antioxidant effectiveness	HPLC-UV-DAD HPLC-MS-ESI analysis to determine the main polyphenolic constituents, namely anthocyanins and	1 All the MeOH extracts showed significant antioxidant activity, with some differences between the two methods	Ruberto <i>et al.</i> , 2007

(Continued)

Table 9.1 (Continued)

No	Kind of waste	Treatment	Parameters	Methodology	Quality control methods	Results	References
			of five Sicilian red grape cultivars were evaluated for their DPPH and ABTS radical scavenging capacity to determine anthocyanins and flavonols	(evaluated as radical-scavenging activity) of the extracts from de-stemmed samples of grape pomace of five important Sicilian cultivars of red wine grape	flavonols, measurement of DPPH radical scavenging activity, evaluation of free radical-scavenging activity with trolox equivalent antioxidant capacity (TEAC) assay	employed 2 The NM sample was the most active in both tests 3 A large variability in the total anthocyanin (TA) and flavonol (TF) contents of the MeOH extracts, as well as in the quantitative distribution of the single anthocyanins and flavonols was observed	
4	Fruit and Vegetable Waster (FWW)	Anaerobic digestion for material recovery and energy production	These wastes contain 8–18% total solids (TS), with a total volatile solids (VS) content of 86–92%. The organic fraction includes about 75% easy biodegradable matter (sugars and hemicellulose), 9% cellulose and 5% lignin	Anaerobic digestion of FWW studied under different operating conditions and bioreactors. Conversion of 70–95% of organic matter to methane. Volumetric organic loading rate (OLR) of 1–6.8 g versatile solids (VS)/l day		The overall results of anaerobic digestion of FWW suggest that the two-stage system is a promising process to treat these wastes with high efficiency in term of degradation yield and biogas productivity. Adaptation of each ecosystem to its own substrate. Biochemical reactions involved in anaerobic digestion of FWW are taken subsequently under conditions similar to those of the rumen	Bouallagui <i>et al.</i> , 2005
5	Passion fruit (PFP) and mandarin peels (MP)	Use of PFP and MP wastes as biosorbents for successful removal of methylene blue from aqueous samples	Initial methylene blue (MB), pH, time of contact	Full 2 ³ factorial designs were employed for screening the factors that would influence the overall optimization of	Spectrophotometric determination of dye	The best conditions for both biosorbents were pH 9.0 for PFP and 11.0 for MP, contact time higher than 48 h for PFP and 42.9 h for MP, initial	Pavan <i>et al.</i> , 2007

				MB removal from aqueous solution employing PFP and MP as biosorbents		concentration (C_0) of MB as low as 3.20 mg/l. Biosorbent mass was fixed to 200.0 mg, temperature to 25°C and stirring to 60 rpm	
6	Fruit juice waste (FR) (orange, apple, pineapple, dates, grape)	Biowaste obtained from the fruit juice industry (FR) was used as biosorbent for the removal of toxic heavy metals (Hg(II), Pb(II), Cd(II), Cu(II), Zn(II) and Ni(II))		Phosphated FR (P-FR) was prepared by treatment of FR with phosphorus (V) oxychloride	Batch adsorption studies, spectrophotometric determinations	<ol style="list-style-type: none"> 1 An efficient removal was obtained with P-FR at low pH 2 Addition of phosphate groups enhanced the adsorption capacity of the biosorbent 3 Since the adsorbent is discharged as a biowaste by industry, the treatment method is expected to be economical 	Senthilkumar <i>et al.</i> , 2000
7	Citrus peel extract	Refluxing the dried ground peel with ethanol, methanol, acetone, hexane, diethyl ether and dichloromethane	Refined, bleached and deodorized corn oil, citrus peel, FFA, POV, IV	Corn oil samples containing 1200, 1600 and 2000 ppm methanolic citrus peel extract. 6 months storage of refined corn oil at 25 and 45°C	Antioxidant activity of methanolic extract was assessed by measuring free fatty acid (FFA) content peroxide value (POV) and iodine value (IV) during 6 months storage of refined corn oil at 25 and 45°C	<ol style="list-style-type: none"> 1 Methanolic extract of citrus exhibited very strong antioxidant activity, which was almost equal to synthetic antioxidants (BHA and BHA) 2 The use of citrus peel extract is recommended as a natural antioxidant to suppress development of rancidity in oils and fats 	Rehman, 2006
8	Fruit and vegetable wastes (FVW)	Anaerobic digestion	Volatile solids (VS) reduction, total methane production and methane yield	A continuously stirred tank reactor was used as a mesophilic (35°C) anaerobic reactor to examine the effect of adding the FVW and chicken manure (CM) to a system	Total and volatile solids and pH were measured. Ammoniacal nitrogen, alkalinity, methane and carbon dioxide concentrations were also measured	High concentrations of volatile fatty acids were produced when FVW was co-digested with cattle slurry with the feed containing 30% or more FVW. Mixtures of CS and FVW, with proportions of FVW of up	Callaghan <i>et al.</i> , 2002

(Continued)

Table 9.1 (Continued)

No	Kind of waste	Treatment	Parameters	Methodology	Quality control methods	Results	References
				which was digesting cattle slurry (CS)		to 50% in the feed, gave a good co-digestion in terms of methane yield, but the VS reduction did decrease slightly. Chicken manure was not very effective as a co-digestate	
9	FVW	Anaerobic digestion	Biogas production, total solids, total volatile solids and pH, total organic carbon (TOC), total nitrogen	Tubular anaerobic digesters on a laboratory scale using psychrophilic, mesophilic and thermophilic processes	Biogas production, total solids, total volatile solids and pH, total organic carbon (TOC), total nitrogen	The resulting higher degradation efficiency in thermophilic conditions was associated with the higher specific biogas production and with the improvement of the energy balance of the process	Bouallagui <i>et al.</i> , 2004a
10	Solar dried citrus pulp (SDCP)	Solar energy	Carcass and meat quality parameters	27 Italian Merino male lambs, weaned at 60 days, placed in individual straw-bedded pens with a fattening period of 80 days preceded by an adaptation period of 10 days	Chemical composition analysis as well as fiber fractions. Physical analysis (redness value, chroma value), carcass compactness, adiposity, water holding capacity measured as cooking loss	SDCP can be incorporated in concentrate mixtures for fattening lambs at levels equal to 30% without adverse effects both in growth and slaughter performances as well as in carcass and meat quality	Caparra <i>et al.</i> , 2006
11	Citrus juice centrifugation pulp	Alkaline and/or enzymatic treatments	Pectolytic enzyme	Alkaline and/or enzymatic treatments were carried out on the centrifugation pulp. These treatments facilitate pressing and so help to produce a material which will be used for animal feed	Crude protein determination with micro-Kjeldahl method, total <i>in vitro</i> digestibility, water content, dry matter determinations	<ol style="list-style-type: none"> 1 Enzymatic treatment proved to be the most efficient method designed to favor the pressing of the pulp 2 The product obtained with this method showed excellent digestibility <i>in vitro</i> and its protein content, although not especially high, 	Tripodo <i>et al.</i> , 2004

12	Grape, black- and redcurrant by-products (marc)	Pressing of the marc, preparation of extracts from redcurrant marc, blackcurrant marc and grape marc using 70% ethanol, 70% methanol and water as solvents	Polyphenols, anthocyanins, antioxidant activity	Marc was obtained after two different maceration ways, classic and carbonic maceration. Classic maceration means that clusters are mixed with must and the must is allowed to ferment, whereas at carbonic maceration the fruit is held in an atmosphere of carbon dioxide and is not bathed by juice from the must	Total polyphenols determination. Measurement of total anthocyanins using pH differential method, measurement of total antioxidant activity using DPPH test, measurement of total antioxidant activity using β -carotene test, HPLC analysis of individual anthocyanins	<p>compared favorably with that of many other agro-industrial waste products currently used as components of animal feed</p> <p>3 Clear environmental benefits to be gained from the recycling of the pulp from centrifuged orange and lemon juice</p> <p>1 There were higher amounts of polyphenols and anthocyanins in methanol and ethanol extracts than in water extracts</p> <p>2 By-products obtained after pressing of redcurrant, blackcurrant and grape still contained large amounts of phenols, especially anthocyanin compounds with antioxidant activity</p> <p>3 Between the investigated materials blackcurrant marc extracts were established to have the highest contents of total polyphenols, total anthocyanins and the highest antioxidant activity</p> <p>4 Grape extracts had high antioxidant activity due to high contents of polphonests</p>	Lapornik <i>et al.</i> , 2005
13	Cranberry waste	Microbial conversion-solid-state fermentation	Glucosamine content	Fungi, such as <i>Trichoderma viride</i> If-26, <i>Trichoderma harzianum</i> ATCC 24274, and <i>Trichoderma pseudokoningii</i>	Protein assay, moisture content, water activity determination, glucosamine assay	1 Bioconversion of cranberry processing waste by industrially beneficial fungi through solid-state fermentation was feasible	Zheng and Shetty, 1998

(Continued)

Table 9.1 (Continued)

No	Kind of waste	Treatment	Parameters	Methodology	Quality control methods	Results	References
				ATCC 26801, a novel polymeric dye decolorizing <i>Penicillium</i> isolate, and a food-grade <i>Rhizopus</i> strain isolated from Tempeh, that produce industrially important extracellular enzymes were grown on a cranberry pomace-based medium at 25°C for 4 days		2 This potential can be coupled with utilization of fish processing waste as an organic nitrogen source to develop mutually complementary products benefiting both the fishery and cranberry processing industries	
14	Watermelon rind	Solvent extraction	Citrulline content	GC-MS was developed to separate citrulline from glutamic acid, which co-elute when analyzed by high performance liquid chromatography (HPLC)	Gas chromatography-mass spectrometry (GC-MS) analysis to determine the citrulline content among varieties, types, flesh colors and tissues	Watermelon rind, an underutilized agricultural waste, offers a source of natural citrulline (a non-essential amino acid)	Rimando and Perkins-Veazie, 2005
15	Citrus peel powder	Lyophilization with 70% ethanol extract from citrus peels. Extraction was carried out at room temperature (20° or 72 h)	Color characteristics and antioxidant potential	The extract was subjected to gamma-irradiation treatment (20 kGy)	Color characteristics (Hunter value) and antioxidant potential in terms of 1,1-diphenyl-2-picrylhydrazyl (DPPH) radical scavenging, β -carotene bleaching and nitrite scavenging activities, heat stability, total phenolic content	<ol style="list-style-type: none"> 1 There were significant changes in Hunter color values due to irradiation 2 DPPH radical scavenging, β-carotene bleaching and nitrite scavenging activities were not affected by irradiation treatment 3 Citrus peel powder could be used as a functional component in the food processing industry with gamma irradiation treatment 	Kang <i>et al.</i> , 2006

16	Vegetable oils contained in waste activated bleaching earth (soybean, palm and rapeseed oil)	Vegetable oils from waste bleaching earth sample were organic-solvent extracted	Saponification value and unsaponifiable matter content were determined, viscosity of refined oils, extracted oils and products from methanolysis	Methanolysis was efficiently catalyzed by <i>Rhizopus oryzae</i> lipase in the presence of high water content and by a single addition of methanol. <i>R. oryzae</i> lipase was not inactivated by methanol in concentrations lower than 4 milliequivalents and 75% water content	Determination of saponification value and unsaponifiable matter content, viscosity of refined oils, extracted oils and products from methanolysis. Fatty acid composition was determined by GC of the methylated fatty acids. Lipase activity was measured with a Lipase Kit S (Dainippon Pharmaceutical Co. Ltd, Osaka)	improving its color characteristics without adversely influencing the functional properties The highest conversion yield reached 55% (w/w) with palm oil after 96 h of reaction. Adverse viscosity conditions might have influenced methanolysis of extracted soybean and rapeseed oil in spite of high water or methanol concentrations. Optimum conditions for methanolysis of extracted oils were 75% water content (by weight of substrate), an oil/methanol molar ratio of 1:4, and 67 IU/g of substrate with shaking of 175 rpm for 96 h at 35°C	Lara Pizarro and Park, 2003
17	Hawthorn fruit (<i>Crataegus pubescens</i>)	Pectinmethylesterase (PME) extraction	Thermal stability, kinetic behavior	The enzyme extraction process was established after studying different NaCl concentrations (0.5–3.0 moles/l). Kinetic parameters (K_m and V_{max}) were determined using a commercial citrus pectin and <i>C. pubescens</i> pectin as substrates	Ionic strength (NaCl concentration), pH and temperature, kinetic parameters (K_m and V_{max}), protein determination, PME activity	Useful information is provided about the factors that affect the activity of <i>C. pubescens</i> PME and might be used as a starting point for texture control during post-harvest handling and processing of this fruit	Vivar-Vera <i>et al.</i> , 2007
18	FWW	Anaerobic digestion for conversion into biogas	The effect of hydraulic retention time (HRT) and the feed concentration	A semicontinuously mixed mesophilic tubular anaerobic digester was employed	HRT, feed concentration total solids (TS), total volatile solids (TVS) and pH, biogas yield, methane content	1 In a tubular digester FWW could be treated anaerobically with a high stability, a high depuration	Bouallagui <i>et al.</i> , 2003

(Continued)

Table 9.1 (Continued)

No	Kind of waste	Treatment	Parameters	Methodology	Quality control methods	Results	References
			on the extent of the degradation of the waste was examined			<p>rate and energy recovery with a good process economy</p> <p>2 The overall performance of the reactor was depressed by changing the feed concentration from 8% to 10% TS (dry weight). By applying a feed concentration of 6% and HRT of 20 days in the tubular digester, 75% conversion efficiency of FVW into biogas with a methane content of 64% was achieved</p>	
19	FVW		Methane yields (B_0) and methane production rate constants (k)	Mixture of vegetable wastes served as feed for the continuously stirred tanks reactor (CSTR)	Biochemical methane potential, methane yields (B_0) and methane production rate constants (k), TS, VS, VFA and pH	<p>1 The ultimate methane yields (B_0) and kinetics of fruit wastes ranged from 0.18 to 0.732 l/g VS added and 0.016 to 0.122/day, respectively and that of vegetable wastes ranged from 0.19 to 0.4 l/g VS added and 0.053 to 0.125/day, respectively</p> <p>2 Temperature had no effect on the B_0 of mango peels, however, the conversion kinetics were higher at 35°C than at 28°C</p> <p>3 Onion peels exhibited yields significantly ($P < 0.05$) similar to</p>	Gunaseelan, 2004

						cellulose, while majority of the vegetable wastes exhibited yields greater than 0.3 l/g VS	
						4 Creation of a database on extent and rates of conversion of fruits and vegetable solid wastes that significantly contribute to organic fraction of municipal solid wastes (OF-MSW)	
20	Citrus peels (Yen Ben lemon, Meyer lemon, grapefruit, mandarin and orange)	Extraction either by ethanol or by simple aqueous extraction	Condition of the peels, temperature of the extraction, solvent concentration and species of citrus	Fruits were immediately peeled after purchase. The tissue removed was the pericarp region (peel), which includes the <i>epicarp</i> and <i>mesocarp</i>	Determination of total phenolics (Folin-Ciocalteu assay) and determination of antioxidant activity by FRAP assay	1 Grapefruit peel had the highest total phenolic contents, followed by mandarin, Yen Ben lemon, orange and Meyer lemon peel 2 High extraction (about 74%) was obtained using ethanol as solvent and the percentage extraction could further be increased using a higher temperature of 80°C 3 The phenolics in grapefruit peels had the highest total antioxidant activity, followed by Yen Ben lemon, mandarin, orange and Meyer lemon	Li <i>et al.</i> , 2006a
21	Citrus peels (Yen Ben lemon, Meyer lemon, grapefruit, mandarin and orange)	Enzyme-assisted aqueous extraction	Condition of the peels, temperature of the extraction, solvent concentration and species of citrus	Fruits were immediately peeled after purchase. The tissue removed was the pericarp region (peel), which	Determination of total phenolics (Folin-Ciocalteu assay) and determination of antioxidant activity by FRAP assay, HPLC analysis.	1. Grapefruit peel had the highest total phenolic contents, followed by mandarin, Yen Ben lemon, orange and Meyer lemon peel 2 Cell-wall degrading	Li <i>et al.</i> , 2006b

(Continued)

Table 9.1 (Continued)

No	Kind of waste	Treatment	Parameters	Methodology	Quality control methods	Results	References
				includes the <i>epicarp</i> and <i>mesocarp</i>		enzymes weakened or broke down the integrity of the cell walls of the citrus peels and eased the extraction. The highest recovery using Celluzyme MX in the enzyme-assisted extraction process was up to 65.5% (about 87.9% of the solvent extraction) 3 The phenolics in grapefruit peels had the highest total antioxidant activity, followed by Yen Ben lemon, mandarin, orange and Meyer lemon	
22	Ensiled sliced oranges	Ensiling	Silage quality, milk yield	Three kilograms (79.5%) sliced orange silage mixture with by-products were offered daily to the animals as experimental treatment, replacing part of the maize grain/soybean meal/oat hay ration given to the controls	Dry matter, nitrogen, fat, crude fiber, ash, Ca and P were determined, pH in silage. Milk samples were analyzed for fat, protein, lactose and non-fat solids	Inclusion of ensiled sliced oranges to diets of lactating sheep is a viable proposition	Volanis <i>et al.</i> , 2004
23	Orange waste	Adsorption gels	Ca ²⁺ -form and H ⁺ -form adsorption gels, metal ion uptake	Saponification of orange juice residues with calcium hydroxide and subsequent acid treatment	Total organic carbon concentration, adsorption tests conventional batch method using aqueous test	1 Both gels were quite effective for removing heavy metal ions in acidic pH ranges 2 The H ⁺ -form gel	Dhakal <i>et al.</i> , 2005

24	FVW	Anaerobic co-digestion	The daily gas production (expressed as l/day) together with the organic loading rate (OLR) (expressed as g VS fed/day)	Digestion of primary sludge (PS) and co-digestion of this sludge with the fruit and vegetable fraction of municipal solid wastes (FVFMSW) under mesophilic conditions. This mixture was prepared with a PS content of 22%. The anaerobic digestion process was evaluated under static conditions and with different mixing conditions	solutions containing single metal ions Total solids (TS), volatile solids (VS), pH and daily biogas production, biogas yield	showed a different adsorption profile for Fe(III) compared to the Ca ²⁺ -form gel	<ol style="list-style-type: none"> 1 Biogas production for co-digestion is much greater due to the larger volatile-solid (VS) content of this feedstock 2 Biogas yield and specific gas production for the two digestion processes are similar, with values in the range 0.6–0.8 l/g VS destroyed for the first parameter and in the range 0.4–0.6 l/gVS fed for the second 3 Evaluation of the co-digestion process at different organic loading rates (OLR) under low mixing conditions, with stable performance being obtained even when the systems were overloaded 	Gómez <i>et al.</i> , 2006
25	WVO (sunflower oil)	Frying oil	Viscosity, density, calorific value and flash point	The performance and exhaust emissions of a single cylinder diesel engine was evaluated using diesel, waste frying oil (without preheating) and waste frying oil preheated to	Viscosity, density, calorific value and flash point		<ol style="list-style-type: none"> 1 Waste frying oil required a heating temperature of 135°C to bring down its viscosity to that of diesel at 30°C 2 The engine performance improved and the CO and smoke emissions were reduced using 	Pugazhvidivu and Jeyachandran, 2005

(Continued)

Table 9.1 (Continued)

No	Kind of waste	Treatment	Parameters	Methodology	Quality control methods	Results	References
26	FVW	Transformation of the extracts from vegetable and fruit processing wastes into the yeast biomass enriched with selenium	Nitrogen, dissolved organic matter, biomass concentration	Water extracts of cabbage, watermelon, a mixture of residual biomass of green salads and tropical fruits were used for yeast cultivation	Enumeration of yeast and bacterial cells, cell growth measurements, total solids, volatile solids, selenium content, carbon and nitrogen content	preheated waste frying oil The extracts from vegetable and fruit processing wastes can be used for production of yeast biomass without any nutrient supplements. It is necessary to sterilize or pasteurize the extract to avoid the growth of contaminated bacterial species <i>Acinetobacter baumannii</i> - <i>Acinetobacter calcoaceticus</i> . It is possible to increase nutrient and economic values of yeast by adding to the medium 5 µg/ml of selenium. Yeast biomass obtained by cultivation in such medium contained 15 µg Se/g of dry biomass	Stabnikova <i>et al.</i> , 2005
27	Lemon juice by-products	Washing and drying	Fiber content and type, microbial quality and physicochemical properties of the fiber	Grinding orange peels to a high particle size (15 mm) and washing with hot water to produce a fiber with high water holding capacity	Water holding capacity, oil holding capacity, fiber content, microbiological analysis, color measurement	<ol style="list-style-type: none"> 1 Water holding capacity was enhanced by washing 2 Oil holding capacity was not affected by those factors 3 Drying was responsible for decrease of bacterial populations 4 High dietary fiber lemon powder obtained 	Lario <i>et al.</i> , 2004

28	Pigmented orange pulp wash (PW)	Adsorption resins	Anthocyanins, flavonons, hydroxycinnamates	The residue of the process was investigated to obtain a purified sugar concentrate applying a series of resin adsorptions and membrane techniques neutral polystyrene-divinylbenzene (PS-DVB) resin used to recover the pigments	Determination of sugars, ascorbic acid, pectins, flavonoids, hydroxycinnamates and limonin, color, HPLC analysis, adsorption and membrane processes	from lemon (Fino cv) by-products has good functional and microbial quality, as well as favorable physicochemical characteristics to be used in food formulations (as meat, dairy and bakery products)	The concentrate, obtained from a residue that otherwise must be disposed of, was a transparent liquid of slight amber color with a very low microbial count and could easily find application as a natural sweetener in food and beverage industries	Scordino <i>et al.</i> , 2007
29	FVW (apple, cherry and pear pomaces; blackcurrant and chokeberry pomaces, carrot)	Prior to physical and chemical determinations, materials were defrosted, dried and ground	Cellulose, hemicellulose, lignin and pectins	Determination of the amounts of particular dietary fiber fractions in samples containing apple, blackcurrant, chokeberry, pear, cherry and carrot pomace	Analysis for contents of dry matter (AOAC), non-starch polysaccharides (NSP) and lignin. Enzymic hydrolysis of the starch, precipitation of NSP in ethanol and acid hydrolysis of the NSP. Fractions of pectins, hemicellulose, cellulose and lignin were obtained	1 In each pomace sample, pectins occurred in the smallest amounts and the content of lignin was very high (blackcurrant and cherry pomace) or comparatively high (pear, chokeberry, apple and carrot pomace). The other dietary fiber components were difficult to form into clearly defined groups. Their proportions varied from one pomace type to another	Nawirska and Kwasniewska, 2005	

(Continued)

Table 9.1 (Continued)

No	Kind of waste	Treatment	Parameters	Methodology	Quality control methods	Results	References
30	Apple seed and peach meal, almond, watermelon, datch	Peeling and extraction	β -glucosidase, o-glucosides	From the crude extract of apple seed meal, a major glucosidase isoenzyme was purified to homogeneity by ammonium sulfate fractionation and chromatographic separation through DEAE-Cellulose, Butyl-Toyoppearl and Sephadex G150 columns. Synthesis of various glucosides	Protein concentration, β -glucosidase assay, determination of initial hydrolysis rates, purification of β -glucosidase from apple seed, molecular mass and pH determination, activity staining, two-dimensional electrophoresis (2-DE), effect of temperature and pH on the enzyme stability, effect of metal ions on the glucosidase activity, kinetic studies	<p>2 The highest contents of hemicellulose and pectins were in chokeberry pomace (41%) and the lowest in apple pomace (36%). Hence, chokeberry and apple pomaces will be equally good sorbents for heavy metals</p> <p>1 The apple seed β-glucosidase was totally different from any of the almond β-glucosidase isozymes reported so far</p> <p>2 The purified enzyme of apple seed displays higher thermal stability than the commercially supplied β-glucosidase from almond</p> <p>3 Searching for excellent β-glucosidase catalysts for enzymatic synthesis of many useful glucoside compounds, apple and peach meal were found to be the most suitable enzyme sources</p>	Yu <i>et al.</i> , 2006
31	Orange peel <i>Citrus sinensis</i> (sweet orange) and <i>Citrus aurantifolia</i> (lime)	Volatile fraction of the peels were extracted by steam distillation	Insecticidal activity	Mosquitoes were bred in stagnant water stored in small plastic bowls over a period of two weeks. Flies and cockroaches were	The number of dead, moribund and live insects after 30 and 60 min, respectively, were noted. The percentage of	Volatile extracts of <i>C. sinensis</i> showed greater insecticidal potency, while the cockroach was the most susceptible to orange peels among	Ezeonu <i>et al.</i> , 2001

				trapped in simple pitfall traps containing purifying organic matter. Experimental insects were released into and allowed to infest a previously whitewashed room	potency of the peel extract was calculated from the number of dead insects and total number of dead, live and moribund insects	the three insects studied	
32	Leaching waste liquid from citric juice production	Reverse osmosis (RO) membrane technology and multiple-effect evaporation system (MEE)	Energy consumption	A sucrose concentration contained in the leaching stream is proposed in order to get citrus molasses and a water stream which could be reused in the citric juice process	Pump power consumption, final concentration (Brix)	<ol style="list-style-type: none"> 1 RO had a 7.7 times lower consumption than MEE 2 The RO process has proven to be effective to preconcentrate sucrose solutions under the experimental conditions considered 3 An almost complete valorization of the leaching liquid can be obtained from a wet pressing of the solid wastes produced from orange juice production 	Garcia-Castello <i>et al.</i> , 2006
33	Citrus waste	Composting by piling under shelter	Microbial, chemical and physical aspects	Supplementation of the waste with calcium hydroxide	Physical and chemical parameters, microbial analysis	<ol style="list-style-type: none"> 1 Raw citrus waste was colonized by mesophilic yeasts 2 Bacteria prevalent in the final product were <i>B. licheniformis</i>, <i>B. macerans</i>, <i>P. vulgaris</i>, <i>P. aeruginosa</i>, <i>P. fluorescens</i> 	Van Heerden <i>et al.</i> , 2002
34	Apricot bagasse	β -carotene extraction using supercritical carbon dioxide fluid extraction system	Pressure, temperature, CO ₂ flow rate and particle size, mass transfer coefficient, effective diffusivity	Shrinking core model was selected as the best mathematical model, which characterized the extraction process, after taking into consideration mass	Physical properties of supercritical CO ₂ and β -carotene. Pressure, temperature determinations	<ol style="list-style-type: none"> 1 β-carotene from freeze-dried apricot bagasse was extracted by using supercritical CO₂ as a solvent to measure the effects of supercritical CO₂ flow rate, particle size, temperature and 	Döker <i>et al.</i> , 2004

(Continued)

Table 9.1 (Continued)

No	Kind of waste	Treatment	Parameters	Methodology	Quality control methods	Results	References
				transfer mechanisms such as adsorption, diffusion, solubility and desorption		pressure on the extraction yield. The experimental data were described by shrinking core model 2 Regarding pressure, temperature, particle size and carbon dioxide flow rate, the model fitted well with the experimental results	
35	FWW	Dehydration	Nutritional and microbiological analyses	The effectiveness of different drying systems used for the dehydration of certain fractions of biodegradable municipal solid wastes with a high moisture content (fruit and vegetable remains) was analyzed. Some tests using small amounts of the material were carried out in natural and forced convection ovens. For larger quantities of wastes, a discontinuous cabinet dryer and a continuous rotary dryer were used. With these dryers, the moisture content was reduced from 800 to 100 g/kg	Nutritional and microbiological analyses of the waste samples were carried out before and after drying. The nutritional parameters determined were moisture, ash, fats, fiber, protein and carbohydrates. Microbiological characterization of the waste was performed, analyzing total aerobic mesophiles, <i>Enterobacteria</i> , molds and yeasts, <i>Salmonella</i> , <i>Escherichia coli</i> and <i>Staphylococcus aureus</i>	Biodegradable municipal wastes collected from the produce sections (fruit and vegetables) of large supermarkets have a potential for recycling and for use as fodder	Pinacho <i>et al.</i> (In press)
36	Peach and apricot stones	Combustion using a fluidized bed	Combustion efficiency	At the start up, the bed material	On-line concentrations of O ₂ , CO, CO ₂ , SO ₂ ,	1 The volatile matter from peach and	Kaynak <i>et al.</i> , 2005

		combustor (BFBC).		(sand) was fed into the system. Then the BFBC was heated first with natural gas to 700°C. After the required temperature was reached, the fuel prepared in advance and stored in the fuel hopper was fed into the BFBC. The natural gas supply was gradually decreased and shut down after the combustion was self-sustained	NO _x and total hydrocarbons (CmHn) were measured in the flue gas during combustion experiments, emission of various pollutants, temperature distribution	apricot stones quickly volatilizes and mostly burn in the freeboard 2 Peach and apricot stones are potential fuels that can be utilized for clean energy production in small-scale fruit juice industries by using BFBC	
37	Cactus pear juice	Carborundum peel removal from pulp and passing through a finisher	Betalain-based coloring foodstuff	For improved filtration of cactus pear juice different enzyme preparations were tested to degrade pectic-like substances	Lightness, chroma, hue angle, glucose, fructose and l-ascorbic acid, 5-hydroxymethyl-furfural (HMF) using HPLC analysis, betalain content, non-enzymatic browning	1 Even after repeated thermal treatment neither non-enzymatic browning nor HMF formation was observed in juices from both cultivars 2 Juice concentrates from cactus pear are expected to be a suitable coloring foodstuff for low acid products such as ice-cream or yogurt where the application of anthocyanin-based colorants is limited	Moßhammer <i>et al.</i> , 2005

(Continued)

Table 9.1 (Continued)

No	Kind of waste	Treatment	Parameters	Methodology	Quality control methods	Results	References
38	Vegetable, fruit and garden wastes (VFG)	Composting	Silage maize N uptake and N concentration	The effects of the application of this VFG compost on silage maize on a sandy loam soil was studied. A yearly application of 22.5 Mg of VFG compost/ha, in addition to 42 Mg of cattle slurry/ha resulted in economical optimum dry matter yields with a substantial saving of mineral fertilizer N	Soil organic matter, total nitrogen concentration, silage maize dry matter yield, soil pH, available K and Ca concentrations, available P	<ol style="list-style-type: none"> 1 Economical optimum dry matter yields with a substantial saving of mineral fertilizer N 2 Silage maize N uptake and N concentration in maize were higher when compost was applied. Despite the low N output/input rate with compost application, it did not result in an excessive amount of residual soil nitrate-N, provided that the additional mineral fertilizer N was adapted to the economic optimum level 3 Compared to slurry application, 4 years of VFG compost application resulted in significantly higher soil organic matter and total nitrogen concentrations 	Nevens and Reheul, 2003
39	Citrus fruits	Pectinase grown on pectin from citrus fruits as a substrate	Pectinase	An extracellular pectinase (PECI) was purified from liquid state cultures of the thermophilic fungus <i>Acrophialophora nainiana</i> by ultrafiltration and a combination of gel filtration and	Determination of molecular masses of PECI by SDS-PAGE and mass spectrometry. The thermostability of purified PECI was investigated by fluorescence and circular dichroism spectroscopy, pectinase assay, amino acid sequence analysis	<ol style="list-style-type: none"> 1 First report on the purification and characterization of a pectinase from <i>A. nainiana</i> 2 PECI is a thermal stable protein exhibiting maximum stability at alkaline pH, encouraging its use in the degumming and retting of fiber crops 	Celestino <i>et al.</i> , 2006

				ion-exchange chromatographic procedures		and pretreatment of pectic wastewater from fruit juice industries	
40	<i>Citrus unshiu</i> peels	Extraction, filtration, pectin precipitation, sugar removal	Narirutin	Recovery of narirutin from a water-extract of <i>C. unshiu</i> peels using a non-ionic acrylic ester polymer resin	Changes in the content of narirutin, hesperidin and total sugars were analyzed, batch adsorption and desorption of narirutin, HPLC analysis	3 PEC I is an exopoly-methylgalacturonate lyase The recovery of narirutin from water-extracts of <i>Citrus unshiu</i> peels can be easily and effectively achieved via adsorption and desorption on Amberlite XAD-7, which has been shown to generate a final recovery yield of approximately 84%	Kim <i>et al.</i> , 2007
41	Orange waste	Adsorption	Cadmium	The orange waste was first cut into small pieces, was extensively washed with tap water to remove adhering dirt and soluble components such as tannins, resins, reducing sugar and coloring agents, and then was oven-dried at 50–60°C until constant weight. The washed and dried material was crushed and sieved	Fourier transform infrared spectroscopy (FTIR) to characterize biomass, kinetics, adsorption studies	1 Orange waste from the orange juice industry can be considered as a potential biosorbent material for the removal of Cd(II) ions from aqueous solutions 2 The FTIR spectra of the biosorbent before and after the adsorption shows that the adsorption capacity can be related to the carboxylic and the alcoholic hydroxyl groups of the orange waste	Pérez-Marín <i>et al.</i> , 2007
42	FWW	Two-phase anaerobic digestion	VFA, COD	Two coupled anaerobic sequencing batch reactors (ASBR) operated at mesophilic temperature were employed. The effect	Volatile fatty acids (VFA), COD, total solids (TS), total volatile solids (TVS), total suspended solids (TSS), pH, total nitrogen Kjeldahl (TNK)	1 FWW is highly biodegradable with a conventional two-phase reactor and 96% of the total COD was converted to biomass and biogas 2 The hydrolysis yield (81%) stabilized	Bouallagui <i>et al.</i> , 2004b

(Continued)

Table 9.1 (Continued)

No	Kind of waste	Treatment	Parameters	Methodology	Quality control methods	Results	References
				of increasing loading rates on the acidification step was investigated		<p>at an OLR of 7.5 g COD/l/day</p> <p>3 The volatile fatty acids concentration increased when the loading rate was increased and reached its maximum value (13.3 g/l) at higher loading rate tested (10.1 g COD/l/day)</p> <p>4 Methanogenic fermentation of the liquefaction acidification products was efficiently performed in the ASBR reactor and high methane productivity was obtained</p> <p>5 Total COD in the final effluent from the methanizer was usually below 1500 mg/l, and soluble COD below 400 mg/l</p>	
43	Orange peel	Synthetic dyes adsorption	Direct red dyes	A numerical finite element model to simulate the removal of dissolved textile synthetic dyes from wastewater taking into consideration both linear and the Langmuir isotherms to describe adsorption process	Adsorption measurements	<p>1 The model results presented can help to design an appropriate environmental management strategy to minimize the adverse impacts caused by industrial wastewater</p> <p>2 The parameter values in the model were obtained from an experimental test for</p>	Ardejani <i>et al.</i> , 2006

44	FWW	Two-phase anaerobic digestion	VFA, COD	Two coupled anaerobic sequencing batch reactors (ASBR) operated at mesophilic temperature were employed. The effect of increasing loading rates on the acidification step was investigated	Volatile fatty acids (VFA), COD, total solids (TS), total volatile solids (TVS), total suspended solids (TSS), pH, total nitrogen Kjeldahl (TNK)	<p>the removal of dyes Direct Red 23 and Direct Red 80 from textile wastewaters using orange peel as a low-cost adsorbent</p> <p>3 The results of the model somewhat agreed with the measured quantities. It was found that the adsorption process by orange peel adsorbent could be well described by the Langmuir isotherm</p> <p>1 FWW is highly biodegradable with a conventional two-phase reactor and 96% of the total COD was converted to biomass and biogas</p> <p>2 The hydrolysis yield (81%) stabilized at an OLR of 7.5 g COD/l/day</p> <p>3 The volatile fatty acids concentration increased when the loading rate was increased and reached its maximum value (13.3 g/l) at higher loading rate tested (10.1 g COD/l/day)</p> <p>4 Methanogenic fermentation of the liquefaction acidification products was efficiently performed in the ASBR reactor and high methane productivity was obtained</p> <p>5 Total COD in the final effluent from the methanizer was usually below 1500 mg/l and soluble COD below 400 mg/l</p>	Bouallagui <i>et al.</i> , 2004b
----	-----	-------------------------------	----------	--	--	---	----------------------------------

(Continued)

Table 9.1 (Continued)

No	Kind of waste	Treatment	Parameters	Methodology	Quality control methods	Results	References
45	Citrus fruit wastes	Extraction of the liquid content from these solid wastes, wet pressing, and afterwards treating the pressed liquid, which is very rich in sucrose, by reverse osmosis as a preconcentration system	Sucrose solutions, NaCl	A concentrated stream is treated later in an evaporation system to achieve citrus molasses (65° Brix) and a permeate one with a very low sucrose content to be reused in the production process	COD determination of sucrose concentration, NaCl determination using the conductivity technique	<ol style="list-style-type: none"> 1 The RO process has proved to be effective for concentrating sucrose solutions but, due to the high osmotic pressure, the polarization-concentration effect is higher than in NaCl solutions 2 The concentration and effective pressure are, in fact, the most important factors related with the RO preconcentration process 	Garcia <i>et al.</i> , 2002
46	Dehydrated orange peel	Supercritical CO ₂ extraction	Orange essential oil	To study the influence of pressure and temperature, a series of experiments was designed to be performed in the 8–28 MPa pressure range and in the 293–323 K temperature range. To study the influence of solvent mass flow and particle size of orange peel on extraction rate, two series of experiments were designed	Gas chromatography, mass spectrometry	Limonene is the principal component extracted. At 12.5 MPa and 308 K the limonene content in the essential oil extracted is more than 99.5%. It was also observed that essential oil of orange peel showed the higher concentration in linalool at 80 bar and 35°C	Mira <i>et al.</i> , 1999
47	Palm oil mill effluent	Ceramic ultrafiltration membrane	Transmembrane pressure, cross-flow velocity	The pretreatment processes inclusive of coagulation/flocculation, latex adsorption and	Transmembrane pressure, cross-flow velocity, COD, BOD and suspended solids content	<ol style="list-style-type: none"> 1 Both transmembrane pressure and cross-flow velocity show their significant effects to the 	Ahmad <i>et al.</i> , 2005

				activated carbon treatment		permeate flux, whereas only the cross-flow velocity influences the rejection of dissolved organic matters in terms of COD and BOD	
48	Pineapple waste and juice	Peeling, blending followed by extraction	Ethanol fermentation	Ethanol fermentation using unhydrolyzed and enzymatically hydrolyzed pineapple waste material was also investigated under various culture conditions	Cellulase assay, determination of ethanol concentration using gas chromatography (GC)	<p>2 The application of membrane separation technology to treat this agro-based effluent has improved the quality of the final effluent discharge compared to the conventional treatment system which is based on physical and biological treatment</p> <p>These results suggest that pineapple juice and the waste material can be useful low-cost substrates for ethanol production from <i>Z. mobilis</i> without supplementation with expensive organic nitrogen complexes such as yeast extract and without the regulation of the pH during cultivation, leading to the reduction in the production costs</p>	Tanaka <i>et al.</i> , 1999
49	Orange peels	Microwave extraction, Soxhlet extraction and hand-pressing extraction	Pectin	The flavedo, which is the outside skin of the orange peel, was removed by a fruit peeler. The	Total nitrogen, pectin concentration, GC-MS, pH	The combination of hand-pressure and microwave on pectin yield from flavedo was 12% better than	Liu <i>et al.</i> , 2006

(Continued)

Table 9.1 (Continued)

No	Kind of waste	Treatment	Parameters	Methodology	Quality control methods	Results	References
				flavado and albedo were cut into small pieces. To get a representative sample, the flavado and albedo from four oranges were well mixed within each (flavado and albedo) sample, separately		hand-pressure alone, which was also better than microwave extraction alone	
50	Orange peel	Cell immobilization	Alcoholic fermentation	A biocatalyst was prepared by immobilizing a commercial <i>Saccharomyces cerevisiae</i> strain (baker's yeast) on orange peel pieces	Determination of viable cells/ml of fermentation broth and viable cells/g orange peel. Fermentation kinetics were monitored by measuring the density ($^{\circ}\text{Be}$) of the fermenting liquids. Ethanol concentration was obtained both by GC and HPLC. Ethanol productivity was calculated as g of ethanol per liter liquid volume produced per day (g/d). Ethanol and residual sugar were determined by HPLC. Electron microscopy measurements were also carried out	Reasonable amounts of volatile by-products were produced at all temperatures studied, revealing potential application of the proposed biocatalyst (orange peel) in fermented food applications, to improve productivities and quality	Plessas <i>et al.</i> , 2007

America and Ecuador. Some of the largest plantations of *C. pubescens* flourish in Mexico, with an important annual fruit production (24 000 T) during the fall (Secretaria de Agricultura Ganaderia, Desarrollo Rural, and Pescay Alimentacio' n (SAGARPA), 2004). The species *C. pubescens* produces the largest fruits in the genus with specimens up to 44.42 mm in diameter. These fruits are like small apples, with a thin skin covering a fleshy pulp. They are green and hard in the unripe stage and during ripening they become sweet, with a soft flesh and a skin color ranging from yellow through red to dark purple (Herrera-Guadarrama, 1990). They are rich in vitamin C, carotene and mineral salts, mainly calcium, phosphorus, iron and also have a high content of pectin (Morales *et al.*, 1999). Many food products, like concentrated pulp, jam, jellies and marmalades can be processed from this fruit, making it of economical importance, however, the full potential of this fruit has not been exploited yet (Borys, 1996). This is probably due to the short shelf-life of the fruits (4–8 days) (Vivar-Vera *et al.*, 2006).

Cold pressed seed oils

In addition to olive oil, a rich source of natural antioxidants, some cold pressed seed oils have recently become commercially available (Boskou, 2006). The seeds used are agricultural by-products and some of them are good sources of tocopherols and biologically important carotenoids. Cold pressed marionberry, boysenberry, raspberry, blueberry, black caraway, blackcurrant, carrot, cranberry and hemp seed oils have been reported to contain antioxidants and possess a remarkable radical scavenging activity and oxygen radical absorption capacity when tested with the DPPH (1,1-diphenyl-2-picrylhydrazyl) and ABTS cation {2,20-azino-bis (3-ethylbenzo-thiazoline-6-sulfonic acid) diammonium salt} radical-scavenging assays or the oxygen radical absorption capacity (ORAC) assay (Yu *et al.*, 2005; Parry *et al.*, 2005). The nature of the antioxidants is not yet known but, due to the mode of preparation, these oils retain phenols present in the seed and they may have the potential for applications in the promotion of health and prevention against oxidation damage mediated by radicals. Another cold pressed seed oil currently being investigated is date seed oil (Besbes *et al.*, 2004).

Comparison of waste treatment methods

The comparative presentation of the various fruit waste treatment methodologies showed that membrane processes (low energy cost, reliability, reduced capital cost) are the most environmentally friendly techniques. Biogas production appears to be another promising and energy effective waste treatment method. Table 9.1 provides a synoptical presentation of the most important fruit waste treatment methods (parameters, quality control and results).

Conclusions

Waste management in fruit production is a difficult problem to handle and its optimum solution must foresee local factors to be taken into account. Among them are the type

of fruit extraction process in use, the possibility of handling and storing the wastes, the volume of the wastes and land availability. Supercritical extraction seems to be a very efficient way.

Waste treatment methods were divided in two categories: the currently employed and the novel ones. Although novel methods (bioremediation, biogas production, membrane technologies, supercritical and subcritical fluid extraction) appear to be promising and attractive alternatives, handicaps like high cost, requirements for trained personnel and high capital investment are still holding them back from widespread application in the fruit waste industry.

Current research has been classified into five areas of by-products use:

- 1 bioremediation, including anaerobic fermentations, methanogenesis and initial remediation
- 2 land fertilizer and animal feed
- 3 biotransformations and bioperoxidase catalysts
- 4 biochemical reactions such as biofuels and biodegradable plastics
- 5 separation and recovery of components, such as extraction.

References

Scientific references

- Agarwal, A.K. and Das, L.M. (2001). Biodiesel development and characterization for use as a fuel in compression ignition engines. *J Eng Gas Turbines Power* **123**, 440–447.
- Ahmad, A.L., Ismail, S. and Bhatia, S. (2005). Ultrafiltration behavior in the treatment of agro-industry effluent: pilot scale studies. *Chem Engin Sci* **60**, 5385–5394.
- Anand, J.C. and Maini, S.B. (1997). Utilisation of fruit and vegetable wastes. *Ind Food Packer* **51**, 45–63.
- Ardejani, F.D., Badii, K., Limaee, N.Y. *et al.* (2006). Numerical modelling and laboratory studies on the removal of Direct Red 23 and Direct Red 80 dyes from textile effluents using orange peel, a low-cost adsorbent. *Dyes Pigments* 1–8.
- Armesto, L., Bahillo, A., Cabanillas, A. *et al.* (2003). Co-combustion of coal and olive oil industry residues in fluidised bed. *Fuel* **82**, 993–1000.
- Arogba, S.S. (2000). Mango (*Mangifera indica*) Kernel: Chromatographic Analysis of the Tannin, and Stability Study of the Associated Polyphenol Oxidase Activity. *Journal of Food Composition and Analysis* **13**(2), 149–156.
- Arriaga, F.J. (1989). Aprovechamiento de subproductos citricos: *Flavonoides. Alimentacion, Equipos y Tecnología* (Noviembre–Diciembre), 173–179.
- Arvanitoyannis, I.S. and Kassaveti, A. (2007). Current and potential uses of thermally treated olive oil waste. *Int J Food Sci Technol* **42**, 852–867.
- Askar, A. and Treptow, H. (1998). Nebenprodukte bei der Verarbeitung tropischer Fruchte. *Indust Obst- Gemuseverwertung* **83**, 7–13.
- Bampidis, V.A. and Robinson, P.H. (2006). Citrus by-products as ruminant feeds: a review. *Anim Feed Sci Technol* **128**, 175–217.

- Besbes, S., Blecker, C., Deroanne, C., Bahloul, N., Lognay, G. and Drira, N.E. (2004). Date seed oil: phenolic, tocopherols and sterol profiles. *J Food Sci* **11**, 251–265.
- Bocco, A., Cuvelier, M.E., Richard, H. and Berset, C. (1998). Antioxidant activity and phenolic composition of citrus peel and seed extracts. *J Agricult Food Chem* **46**, 2123–2129.
- Bonilla, F., Mayen, M., Merida, J. and Medina, M. (1999). Extraction of phenolic compounds from red grape marc for use as food lipid antioxidants. *Food Chem* **66**, 209–215.
- Borys, M.W. (1996). Valores del tejocote (*Crataegus* spp.) diversificación de caracteres. *Rev Chapingo, Horticult* **5**, 51–84.
- Boskou, D. (2006). Sources of natural phenolic antioxidants. *Trends Food Sci Technol* **17**(9), 505–512.
- Bouallagui, H., Cheikh, R.B., Marouani, L. and Hamdi, M. (2003). Mesophilic biogas production from fruit and vegetable waste in a tubular digester. *Bioresource Technol* **86**(1), 85–89.
- Bouallagui, H., Haouari, O., Touhami, Y., Cheikh, R. Ben, Marouani, L. and Hamdi, M. (2004a). Effect of temperature on the performance of an anaerobic tubular reactor treating fruit and vegetable waste. *Process Biochem* **39**(12), 2143–2148.
- Bouallagui, H., Torrijos, M., Godon, J. J. *et al.* (2004b). Two-phases anaerobic digestion of fruit and vegetable wastes: bioreactors performance. *Biochem Engin J* **21**(2), 193–197.
- Bouallagui, H., Touhami, Y., Cheikh, R.B. and Hamdi, M. (2005). Bioreactor performance in anaerobic digestion of fruit and vegetable wastes. *Process Biochem* **40**(3–4), 989–995.
- Braddock, R.J. (1995). By-products of citrus fruit. *Food Techn* **49**, 74–77.
- Braddock, R.J. (1999). *Handbook of citrus by-products and processing technology*, pp. 35–207. Wiley, New York.
- Bravo, L. and Saura-Calixto, F. (1998). Characterization of dietary fiber and the in vitro indigestible fraction of grape pomace. *Am J Enol Viticult* **49**, 135–141.
- Callaghan, F.J., Wase, D.A.J., Thayanithy, K. and Forster, C.F. (2002). Continuous co-digestion of cattle slurry with fruit and vegetable wastes and chicken manure. *Biomass Bioenerg* **27**, 71–77.
- Cameron, R.G., Baker, R.A. and Grohmann, K. (1997). Citrus tissue extracts affect juice cloud stability. *J Food Sci* **62**(2), 242–245.
- Caparra, P., Foti, F., Scerra, M., Sinatra, M.C. and Scerra, V. (2006). Solar-dried citrus pulp as an alternative energy source in lamb diets: effects on growth and carcass and meat quality. *Small Ruminant Res* **68**, 303–311.
- Cavaleiro, A.J., Alves, M.M. and Mota, M. (2001). Microbial and operational response of an anaerobic fixed bed digester to oleic acid overloads. *Process Biochem* **37**, 387–394.
- Celestino, S.M.C., de Freitas, S.M., Medranoc, F.J., de Sousa, M.V. and Ferreira Filho, E.X. (2006). Purification and characterization of a novel pectinase from *Acrophialophora nainiana* with emphasis on its physicochemical properties. *J Biotechnol* **123**, 33–42.
- Chienthavorn, O. and Su-in, P. (1999). Modified superheated water extraction of pesticides from spiked sediment and soil. *Anal Bioanal Chem* **385**, 83–89.
- Chung, S.L. and Meyers, S.P. (1979). Bioprotein from banana waste. *Develop Indust Microbiol* **20**, 723–731.
- Cliffe, K.R. and Patumsawad, S. (2001). Co-combustion of waste from olive oil production with coal in a fluidised bed. *Waste Manage* **49**, 49–55.

- Coll, M.D., Coll, L., Laencine, J. and Tomas-Barberan, F.A. (1998). Recovery of flavanons from wastes of industrially processed lemons. *Zeits Lebensmittel-Untersuch-Forsch A* **206**, 404–407.
- Correia, R.T.P., McCue, P., Magalhaes, M.M.A., Macedo, G.R. and Shetty, K. (2004). Production of phenolic antioxidants by the solidstate bioconversion of pineapple waste mixed with soy flour using *Rhizopus oligosporus*. *Process Biochem* **39**, 2167–2172.
- Crandall, P.G., Matthews, R.F. and Baker, R.A. (1983). Citrus beverage clouding agents. Review and status. *Food Technol* (December), 106–109.
- Dhakal, R.P., Ghimire, K.N. and Inoue, K. (2005). Adsorptive separation of heavy metals from an aquatic environment using orange waste. *Hydrometallurgy* **79**, 182–190.
- Döker, O., Salgin, U., Sanal, I., Mehmetoglu, Ü. and Çalimli, A. (2004). Modeling of extraction of β -carotene from apricot bagasse using supercritical CO₂ in packed bed extractor. *J Supercrit Fluids*, **28**, 11–19.
- Duke, S.O., Dayan, F.E., Romagni, J.G. and Rimando, A.M. (2000). Natural products as sources of herbicides: current status and future trends. *Weed Res* **10**, 99–111.
- Edwards, L., Burney, J.R., Richter, G. and MacRae, A.H. (2000). Evaluation of compost and straw mulching on soil-loss characteristics in erosion plots of potatoes in Prince Edward Island, Canada. *Agricult Ecosyst Environ* **81**(3), 217–222.
- Endreß, H.-U. (2000). Gehobene Qualität durch Produkt-Integrierten Umweltschutz-PIUS. *Flussiges Obst* **67**, 460–463.
- Espachs-Barroso, A., Soliva-Fortuny, R.C. and Martín-Belloso, O. (2005). A natural clouding agent from orange peels obtained using polygalacturonase and cellulase. *Food Chem* **92**, 55–61.
- Evanylo, G.K. and Daniels, W.L. (1999). Paper mill sludge composting and compost utilization. *Compos Sci Utiliz* **72**, 30–39.
- Ezeonu, F.C., Chidume, G.I. and Udedi, S.C. (2001). Insecticidal properties of volatile extracts of orange peels. *Bioresource Technol* **76**, 273–274.
- Fernández, A., Sánchez, A. and Font, X. (2005). Anaerobic co-digestion of a simulated organic fraction of municipal solid wastes and fats of animal and vegetable origin. *Biochem Engin J* **26**(1), 22–28.
- Fernandez-Lopez, J., Fernandez-Gines, J.M., Aleson-Carbonell, L., Sendra, E., Sayas-Barbera, E. and Perez-Alvarez, J.A. (2004). Application of functional citrus by-products to meat products. *Trends Food Sci Technol* **15**, 176–185.
- Foo, L.Y. and Lu, Y. (1999). Isolation and identification of procyanidins in apple pomace. *Food Chem* **64**, 511–518.
- Forgacs, E., Csehati, T. and Oros, G. (2004). Removal of synthetic dyes from wastewaters: a review. *Environ Int* **30**, 953–971.
- Fujihara, S. and Shimizu, T. (2003). Growth inhibitory effect of peel extract from *Citrus junos*. *Plant Growth Reg* **3**, 223–233.
- Gagnon, B., Lalande, R. and Fahmy, S.H. (2001). Organic matter and aggregation in a degraded potato soil as affected by raw and composted pulp residue. *Biol Fert Soils* **34**, 441–447.
- Garcia, E., Gozalvez, J.M. and Lora, J. (2002). Use of reverse osmosis as a preconcentration system of waste leaching liquid from the citric juice production industry. *Desalination* **148**, 137–142.

- Garcia-Castello, E., Lora-Garcia, J., Garcia-Garrido, J. and Rodriguez-Lopez, A.D. (2006). Energetic comparison for leaching waste liquid from citric juice production using both reverse osmosis and multiple-effect evaporation. *Desalination* **191**, 178–185.
- Girdhar, N. and Satyanarayana, A. (2000). Grape waste as a source of tartrates. *Ind Food Packer* **54**, 59–61.
- Gómez, X., Cuetos, M.J., Cara, J., Morán, A. and García, A.I. (2006). Anaerobic co-digestion of primary sludge and the fruit and vegetable fraction of the municipal solid wastes: Conditions for mixing and evaluation of the organic loading rate. *Renewable Energy* **31**(12), 2017–2024.
- Gorinstein, S., Martín-Belloso, O., Park, Y. *et al.* (2001). Comparison of some biochemical characteristics of different citrus fruits. *Food Chem* **74**, 309–315.
- Grasser, L.A., Fadel, J.G., Garnett, I. and DePeters, E.J. (1995). Quantity and economic importance of nine selected by-products used in California dairy rations. *J Dairy Sci* **78**, 962–971.
- Grigelmo-Miguel, N. and Martín-Belloso, O. (1999). Characterization of dietary fiber from orange juice extraction. *Food Res Int* **31**(5), 355–361.
- Grohmann, K., Manthey, J.A., Cameron, R.G. and Buslig, B.S. (1999). Purification of citrus peel juice and molasses. *J Agricult Food Chem* **47**, 4859–4867.
- Gunaseelan, V. N. (2004). Biochemical methane potential of fruits and vegetable solid waste feedstocks. *Biomass Bioenergy* **26**(4), 389–399.
- Hamdi, M. (1996). Anaerobic digestion of olive mill wastewater: a review. *Process Biochem* **31**, 105–110.
- Hang, Y.D. (1988). Recovery of food ingredients from grape pomace. *Process Biochem* **23**, 2–4.
- Hang, Y.D. and Woodams, E.E. (1985). Grape pomace a novel substrate for microbial production of citric acid. *Biotechnol Lett* **7**, 253–254.
- Herrera-Guadarrama, A.J. (1990). Fruit size and inorganic composition of cultivated Mexican hawthorns grafted onto a common stock. *Acta Horticult* **274**, 93–102.
- Herrero, M., Cifuentes, A. and Ibanez, E. (2006). Sub- and supercritical fluid extraction of functional ingredients from different natural sources: plants, food-by-products, algae and microalgae – a review. *Food Chem* **98**, 136–148.
- Hussein, A., Mahvi, D., Naghipour, D., Vaezi, F. and Nazmara, S. (2005). Tea waste as an adsorbent for heavy metal removal from industrial wastewaters. *Am J Appl Sci* **2**(1), 372–375.
- Inukai, F., Suyama, Y., Sato, I. and Inatomi, H. 1966. *Meiji Daigaku Nogakubu Kenkyu Hokoku* **20**, 29.
- Jackson, M.J., Line, M.A., Wilson, S. and Hetherington, S.J. (2000). Application of composted pulp and paper mill sludge to a young pine plantation. *J Environ Qual* **29**, 407–414.
- Jagtiani, J., Chan, H.T. and Sakai, W.S. (1988). Papaya. In *Tropical fruit processing*, pp. 105–147. Academic Press, San Diego, USA.
- Jamode, A.V., Rao, M., Chandak, B.S., Jamode, V.S. and Parwate, A.V. (2003). Applications of the inexpensive adsorbents for the removal of heavy metals from industrial waste water: a brief review. *J Ind Pollut Control* **19**(1), 114–134.
- Jeong, S.-M., Kim, S.-Y., Kim, D.-R. *et al.* (2004). Effect of heat treatment on the antioxidant activity of extracts from citrus peels. *J Agricult Food Chem* **52**, 3389–3393.

- Jimenez-Carmona, M.M. and Luque de Castro, M.D. (1999). Isolation of Eucalyptus essential oil for GC-MS Analysis by extraction with subcritical water. *Chromatographia* **50**(9/10).
- Jimenez-Escrig, A., Rincon, M., Pulido, R. and Saura-Calixto, F. (2001). Guava fruit (*Psidium guajava* L.) as a new source of antioxidant dietary fiber. *J Agricult Food Chem* **49**, 5489–5493.
- Kang, H.J., Chawla, S.P., Jo, C., Kwon, J.H. and Byun, M.W. (2006). Studies on the development of functional powder from citrus peel. *Bioresource Technol* **97**, 614–620.
- Kato-Noguchi, H. and Tanaka, Y. (2004). Allelopathic potential of Citrus junos fruit waste from food processing industry. *Bioresource Technol* **94**, 211–214.
- Kaynak, B., Topal, H. and Atimtay, A. T. (2005). Peach and apricot stone combustion in a bubbling fluidized bed. *Fuel Process Technol* **86**(11), 1175–1193.
- Kennedy, M., List, D., Lu, Y. *et al.* (1999). Kiwifruit waste and novel products made from kiwifruit waste: uses, composition and analysis. In *Modern methods of plant analysis* (H.-F. Linskens and J. F. Jackson, eds), vol. 20, pp. 121–152. Springer, Berlin.
- Kim, M.R., Kim, W.C., Lee, D.Y. and Kim, C.W. (2007). Recovery of narirutin by adsorption on a non-ionic polar resin from a water-extract of *Citrus unshiu* peels. *J Food Engin* **78**(1), 27–32.
- Kotzamanidis, C.H., Arvanitoyannis, I.S., Skaracis, G.N. and Hadjiantoniou, D.Ch. (2000). Implementation of HACCP to a production line of beet sugar, molasses and pulp: a case study. *Zucker Industr (Sugar Indust)* **125**, 970–976.
- Krishna, C. (1999). Production of bacterial cellulases by solid state bioprocessing of banana wastes. *Bioresource Technol* **69**, 231–239.
- Krishna, C. and Chandrasekaran, M. (1996). Banana waste as substrate for alpha-amylase production by *Bacillus subtilis* (CBTK 106) under solid-state fermentation. *Appl Microbiol Biotechnol* **46**, 106–111.
- Kumar, D., Jain, V.K., Shanker, G. and Srivastava, A. (2003). Utilisation of fruits waste for citric acid production by solid state fermentation. *Process Biochem* **38**, 1725–1729.
- Lafuente, B.F. (1980). Frutos, productos hortícolas y derivados. *Rev Agroquim Tecnol Aliment* **20**(1), 13–21.
- Lapornik, B., Prosek, M. and Wondra, A.G. (2005). Comparison of extracts prepared from plant by-products using different solvents and extraction time. *J Food Engin* **71**, 214–222.
- Lara Pizarro, A.V. and Park, E.Y. (2003). Lipase-catalyzed production to biodiesel fuel from vegetable oils contained in waste activated bleaching earth. *Process Biochem* **38**(7), 1077–1082.
- Lario, Y., Sendra, E., Garcia-Perez, J. *et al.* (2004). Preparation of high dietary fiber powder from lemon juice by-products. *Innovat Food Sci EmergTechnol* **5**, 113–117.
- Larrauri, J.A. (1999). New approaches in the preparation of high dietary fibre powders from fruit by-products. *Trends Food Sci Technol* **10**, 3–8.
- Laufenberg, G., Kunz, B. and Nystroem, M. (2003). Transformation of vegetable waste into value added products: (A) the upgrading concept, (B) practical implementations. *Bioresource Technol* **87**(2), 167–198.
- Lee, H.S. (2000). Process for the recovery of carotenoid pigments from red grapefruit juice. In *Proceedings of the international society of Citricult IX Congress* Vol. 2, pp. 1177–1178.

- Lee, S.H., Jung, C.H., Chung, H., Lee, M.Y. and Yang, J.W. (1998). Removal of heavy metals from aqueous solution by apple residues. *Process Biochem* **33**, 205–211.
- Li, B.B., Smith, B. and Hossain, M.M. (2006a). Extraction of phenolics from citrus peels I. Solvent extraction method. *Separat Purificat Technol* **48**, 182–188.
- Li, B.B., Smith, B. and Hossain, M.M. (2006b). Extraction of phenolics from citrus peels II. Solvent extraction method. *Separat Purificat Technol* **48**, 189–196.
- Liu, Y., Shi, J. and Langrish, T.A.G. (2006). Water-based extraction of pectin from flavedo and albedo of orange peels. *Chem Engin J* **120**, 203–209.
- Lommen, A., Godejohann, M., Venema, D.P., Hollman, P.C.H. and Spraul, M. (2000). Application of directly coupled HPLC-NMR-MS to the identification and confirmation of quercetin glycosides and phloretin glycosides in apple peel. *Analyt Chem* **72**, 1793–1797.
- Loo, Y. and Foo, Y. (1999). The polyphenol constituents of grape pomace. *Food Chem* **65**(1), 1–8.
- Louli, V., Ragoussis, N. and Magoulas, K. (2004). Recovery of phenolic antioxidants from wine industry by-products. *Bioresource Technol* **92**, 201–208.
- Lurton, L. (2003). Grape polyphenols: new powerful health ingredients. *Innovat Food Technol* **18**, 28–30.
- Maartens, A., Jacobs, E.P. and Swart, P. (2002). Ultrafiltration of pulp and paper effluent: membrane fouling – prevention and cleaning. *J Membr Sci* **209**, 81–92.
- Mata-Alvarez, J., Cecchi, F., Llabrés, P. and Pavan, P. (1992). Anaerobic digestion of the Barcelona central food market organic wastes: experimental study. *Bioresource Technol* **39**, 39–48.
- Medeiros, R.G., Soffner, M.L.A.P., Thome, J.A. *et al.* (2000). The production of hemicellulases by aerobic fungi on medium containing residues of banana plant as substrate. *Biotechnol Progress* **16**, 522–524.
- Mira, B., Blasco, M., Berna, A. and Subirats, S. (1999). Supercritical CO₂ extraction of essential oil from orange peel. Effect of operation conditions on the extract composition. *J Supercrit Fluids* **14**, 95–104.
- Misi, S.N. and Forster, C.F. (2002). Semi-continuous anaerobic co-digestion of agro-waste. *Environ Technol* **23**, 445–451.
- Morales, J., Babinsky, V., Bourges, R. and Camacho, P. (1999). *Tablas de composicion de alimentos Mexicanos*, pp. 84–85. Instituto Nacional de Nutricion, Mexico.
- Moßhammer, M.R., Stintzing, F.C. and Carle, R. (2005). Development of a process for the production of a betalain-based colouring foodstuff from cactus pear. *Innovat Food Sci Emerging Technol* **6**, 221–231.
- Mouly, P.P., Arzouyan, C.R., Gaydou, E. M. and Estienne, J.M. (1994). Differentiation of citrus juices by factorial discriminant analysis using liquid chromatography of flavanone glycosides. *J Agricult Food Chem* **42**, 70–79.
- Murga, R., Ruiz, R., Beltran, S. and Cabezas, J.L. (2000). Extraction of natural complex phenols and tannins from grape seeds by using supercritical mixtures of carbon dioxide and alcohol. *J Agricult Food Chem* **48**, 3408–3412.
- Nawirska, A. and Kwasniewska, M. (2005). Dietary fibre fractions from fruit and vegetable processing waste. *Food Chemistry* **91**, 221–225.
- Negro, C., Tommasi, L. and Miceli, A. (2003). Phenolic compounds and antioxidant activity from red grape marc extracts. *Bioresource Technol* **87**, 14–41.

- Nevens, F. and Reheul, D. (2003). The application of vegetable, fruit and garden waste (VFG) compost in addition to cattle slurry in a silage maize monoculture: nitrogen availability and use. *Eur J Agron* **19**(2), 189–203.
- Nigam, J.N. (2000). Continuous ethanol production from pineapple cannery waste using immobilized yeast cells. *J Biotechnol* **80**, 189–193.
- Nurgel, C. and Canbas, A. (1998). Production of tartaric acid from pomace of some Anatolian grape cultivars. *Am J Enol Viticult* **49**, 95–99.
- Ozaki, Y., Miyake, M., Inaba, N., Ayano, S., Ifuku, Y. and Hasegawa, S. (2000). Limonoid glucosides of satsuma mandarin (*Citrus unshiu* Marcov.) and its processing products. In *Citrus limonoids: functional chemicals in agriculture and food* (M.A. Berhow, S. Hasegawa and G.D. Manners, eds), pp. 107–119. ACS Symposium Series 758, Washington, DC.
- Ozores-Hampton, M. and Obreza, T.A. (1999). Composted waste use on Florida vegetable crops: a review. In *Proceedings of the International Composting Symposium (ICS'99), Halifax, Nova Scotia, Canada* (P.R. Warman and B.R. Taylor, eds), Vol. I, pp. 827–842. CBA Press, Truro, Canada.
- Pagan, J. and Ibarz, A. (1999). Extraction and rheological properties of pectin from fresh peach pomace. *J Food Engin* **39**, 193–201.
- Palma, M. and Taylor, L.T. (1999). Extraction of polyphenolic compounds from grape seeds with near critical carbon dioxide. *J Chromatogr A* **89**, 117–124.
- Parry, J., Su, L., Luther, M., Zhou, K., Yurawetz, M.P. and Whitetaker, P. (2005). Fatty acid composition and antioxidant properties of cold-pressed marionberry, boysenberry, red raspberry and blue berry seed oils. *J Agricult Food Chem* **53**, 566–573.
- Pavan, F.A., Gushikem, Y., Mazzocato, A.C., Dias, S.L.P. and Lima, E.C. (2007). Statistical design of experiments as a tool for optimizing the batch conditions to methylene blue biosorption on yellow passion fruit and mandarin peels. *Dyes Pigments* **72**, 256–266.
- Pavan, F.A., Lima, I.S., Airoidi, C. and Gushikem, Y. (2006). Use of pokan mandarin peels as biosorbent for toxic metals uptake from aqueous solutions. *J Hazard Mater* doi: 10.1016/j.jhazmat.2006.02.025.
- Pazmino-Duran, E.A., Giusti, M.M., Wrolstad, R.E. and Gloria, A. (2001). Anthocyanins from banana bracts (*Musa x paradisiaca*) as potential food colorant. *Food Chem* **73**, 327–332.
- Pérez-Marín, A.B., Meseguer, V., Ortuño, J.F., Aguilar, M., Sáez, J. and Lloréns, M. (2007). Removal of cadmium from aqueous solutions by adsorption onto orange waste. *J Hazard Mater* **139**(1), 122–131.
- Plessas, S., Bekatorou, A., Koutinas, A.A., Soupioni, M., Banat, I.M. and Marchant, R. (2007). Use of *Saccharomyces cerevisiae* cells immobilized on orange peel as biocatalyst for alcoholic fermentation. *Bioresource Technol* **98**(4), 860–865.
- Pugazhivadivu, M. and Jeyachandran, K. (2005). Investigations on the performance and exhaust emissions of a diesel engine using preheated waste frying oil as fuel. *Renewable Energy* **30**(14), 2189–2202.
- Puravankara, D., Boghra, V. and Sharma, R.S. (2000). Effect of antioxidant principles isolated from mango (*Mangifera indica* L.) seed kernels on oxidative stability of buffalo ghee (butter-fat). *J Sci Food Agricult* **80**, 522–526.
- Rehman, Z.U. (2006). Citrus peel extract – a natural source of antioxidant. *Food Chem* **99**, 450–454.

- Rimando, A.M. and Perkins-Veazie, P.M. (2005). Determination of citrulline in watermelon rind. *J Chromatogr A* **1078**, 196–200.
- Robinson, T., Chandran, B. and Nigam, P. (2002). Removal of dyes from a synthetic textile dye effluent by biosorption on apple pomace and wheat straw. *Water Res* **36**, 2824–2830.
- Rodriguez-Couto, S. and Sanromán, M.A. (2006). Application of solid-state fermentation to food industry – a review. *J Food Engin* **76**, 291–302.
- Ruberto, G., Renda, A., Daquino, C. *et al.* (2007). Polyphenol constituents and antioxidant activity of grape pomace extracts from five Sicilian red grape cultivars. *Food Chem* **100**, 203–210.
- Ruynal, J., Delgenes, J.P. and Moletta, R. (1998). Two phase anaerobic digestion of solid waste by a multiple liquefaction reactors process. *Bioresource Technol* **65**, 97–103.
- Saura-Calixto, F. (1998). Antioxidant dietary fiber product, a new concept and a potential food ingredient. *J Agricult Food Chem* **46**, 4303–4306.
- Schieber, A., Keller, P. and Carle, R. (2001). Determination of phenolic acids and flavonoids of apple and pear by high-performance liquid chromatography. *J Chromatogr A* **910**, 265–273.
- Schieber, A., Stintzing, F.C. and Carle, R. (2001). By-products of plant food processing as a source of functional compounds – recent developments. *Trends Food Sci Technol* **12**, 401–413.
- Scordino, M., Mauro, A.D., Passerini, A. and Maccarone, E. (2007). Highly purified sugar concentrate from a residue of citrus pigments recovery process. *LWT – Food Science and Technology* **40**, 713–721.
- Secretaria de Agricultura Ganadería, Desarrollo Rural, Pesca y Alimentación (SAGARPA) (2004). *Anuario Estadístico de la Producción Agrícola de los Estados Unidos Mexicanos*. SAGARPA, Mexico.
- Senorans, F.J., Ruiz-Rodríguez, A., Cavero, S., Cifuentes, A., Ibanez, E. and Reglero, G. (2001). Isolation of antioxidant compounds from orange juice by using countercurrent supercritical fluid extraction (CC-SFE). *J Agricult Food Chem* **49**, 6039–6044.
- Senthilkumaar, S., Bharathi, S., Nithyanandhi, D. and Subburam, V. (2000). Biosorption of toxic heavy metals from aqueous solutions. *Bioresource Technol* **75**, 163–165.
- Shojaosadati, S.A. and Babaripour, V. (2002). Citric acid production from apple pomace in multi layer packed bed solid state bioreactor. *Process Biochem* **37**, 909–914.
- Siliha, H., El-Sahy, K., Sulieman, A., Carle, R. and El-Badawy, A. (2000). Citrus wastes: composition, functional properties and utilization. *Obst- Gemuse- Kartoffelverarbeitung (Fruit Veg Potato Process)* **85**, 31–36.
- Sinclair, W.B. (1984). *The biochemistry and physiology of the lemon and other citrus fruits*. Division of Agriculture and Natural Resources, University of California, Oakland.
- Sivaraj, R., Namasivayam, C. and Kadirvelu, K. (2001). Orange peel as an adsorbent in the removal of Acid violet 17 (acid dye) from aqueous solutions. *Waste Manage* **21**, 105–110.
- Souquet, J.-M., Cheynier, V., Brossaud, F. and Moutounet, M. (1996). Polymeric proanthocyanidins from grape skins. *Phytochem* **43**, 509–512.
- Sreenath, K.H., Crandall, P.G. and Baker, R.A. (1995). Utilization of citrus by-products and wastes as beverage clouding agents. *J Ferment Bioengin* **80**(2), 190–194.
- Srilatha, H.R., Krishna, N., Sudhakar Bada, K. and Madhukara, K. (1995). Fungal pretreatment of orange processing waste by solid state fermentation for improved production of methane. *Process Biochem* **30**, 327–331.

- Stabnikova, O., Wang, J.-Y., Ding, H.B. and Tay, J.-H. (2005). Biotransformation of vegetable and fruit processing wastes into yeast biomass enriched with selenium. *Bioresource Technol* **96**(6), 747–751.
- Sun, J.-X., Sun, X.-F., Sun, R.-C., Fowler, P. and Baird, M.S. (2003). Inhomogeneities in the chemical structure of sugarcane bagasse lignin. *J Agricult Food Chem* **51**, 6719–6725.
- Tanaka, K., Hilary, Z.D. and Ishizaki, A. (1999). Investigation of the utility of pineapple juice and pineapple waste material as low-cost substrate for ethanol fermentation by *Zymomonas mobilis*. *J Biosci Bioengin* **87**(5), 642–646.
- Tewari, H.K., Marwaha, S.S. and Rupal, K. (1986). Ethanol from banana peels. *Agricult Wastes* **16**, 135–146.
- Tian, S.Y. (2004). A review on the outline and prospect of apple-processing industry in China. *China Fruit* **4**, 32–35.
- Torres, J.L. and Bobet, R. (2001). New flavanol derivatives from grape (*Vitis vinifera*) byproducts. Antioxidant aminoethylthio-flavan-3-ol conjugates from a polymeric waste fraction used as a source of flavanols. *J Agricult Food Chem* **49**, 4627–4634.
- Tripodo, M.M., Lanuza, F., Micali, G., Coppolino, R. and Nucita, F. (2004). Citrus waste recovery: a new environmentally friendly procedure to obtain animal feed. *Bioresource Technol* **91**, 111–115.
- US Department of Agriculture, Agricultural Research Service, USDA National Nutrient Database for Standard Reference, Release 17, 2004; Nutrient Data Laboratory Home Page, <http://www.nal.usda.gov/fnic/foodcomp>.
- Vaccari, G., Tamburinia, E., Sgualdino, G., Urbaniec, K. and Klemes, J. (2005). Overview of the environmental problems in beet sugar processing: possible solutions. *J Cleaner Product* **13**, 499–507.
- Van-Heerden, I., Cronje, C., Swart, S.H. and Kotze, J.M. (2002). Microbial, chemical and physical aspects of citrus waste composting. *Bioresource Technol* **81**, 71–76.
- Veglio, F., Beolchini, F. and Prisciandaro, M. (2003). Sorption of copper by olive mill residues. *Water Res* **37**, 4895–4903.
- Verrier, D., Ray, F. and Albagnac, G. (1987). Two-phase methanization of solid vegetable wastes. *Biol Wastes* **22**, 163–177.
- Vivar-Vera, M.A., Salazar-Montoya, J.A., Calva-Calva, G. and Ramos-Ramirez, E.G. (2007). Extraction, thermal stability and kinetic behavior of pectinmethylesterase from hawthorn (*Crataegus pubescens*) fruit. *LWT – Food Science and Technology* **40**, 278–284.
- Volanis, M., Zoiopoulos, P. and Tzerakis, K. (2004). Effects of feeding ensiled sliced oranges to lactating dairy sheep. *Small Ruminant Res* **53**, 15–21.
- Yano, M., Inoue, K., Makino, K. and Baba, Y. (2001). *Kankyokagakukaishi (in Japanese)* **14**, 345–349.
- Yu, H.L., Xu, J.H., Lu, W.Y. and Lin, G.Q. (2006). Identification, purification and characterization of β -glucosidase from apple seed as a novel catalyst for synthesis of *O*-glucosides. *Enzyme Microb Technol* **40**, 354–361.
- Yu, L.L., Zhou, K.K. and Parry, J. (2005). Antioxidant properties of cold-pressed black caraway, carrot, cranberry, and hemp seed oils. *Food Chem* **91**, 723–729.
- Zheng, Z. and Shetty, K. (1998). Cranberry processing waste for solid state fungal inoculant production. *Process Biochem* **33**(3), 323–329.

Cereal Waste Management: Treatment Methods and Potential Uses of Treated Waste

Ioannis S. Arvanitoyannis and Persefoni Tserkezou

Introduction	629
Treatment methods	631
Uses of wheat, corn, rice, barley and oat wastes	681

Introduction

Cereal crops are mostly grasses cultivated for their edible seeds (actually a fruit called a caryopsis). Cereal grains are grown in greater quantities worldwide than any other type of crop and provide more food energy to the human race than any other crop (<http://en.wikipedia.org/wiki/Grains>). Wheat and rice are the most important crops worldwide as they account for over 50% of the world's cereal production. In the UK, wheat is the cereal most commonly used for the manufacture of food products, although many other types of cereals (e.g. maize and barley) are used. The starchy carbohydrates which are provided by cereals are essential in human nutrition. Rice is a staple diet for half the world's population, the remaining half cultivating the other cereals pending on climate and soil (<http://www.geocities.com/napavalley/6454/cereals.html>). Nowadays, cereals provide a very significant proportion of both human and animal diets despite the fact that most grains are, to a greater or lesser extent, deficient in a number of essential nutrients. A primary problem is the low level of essential amino acids such as lysine, methionine and threonine in the major cereal storage proteins (http://www.agrsci.dk/afdelinger/forskningsafdelinger/gbi/grupper/molekylaer_genetik_og_bioteknologi/cereals).

The seven principal cereals grown in the world are wheat, maize, rice, barley, oats, rye and sorghum. Wheat became very popular because of the bread produced. In Europe, rye was very popular for bread-making. Barley was also introduced from Europe and was commonly grown for its high food value for both animals and humans. Oats had a lower food value than barley but they grow well in the damper climate (<http://www.face-online.org.uk/resources/factsheets/discovering/cereals.doc>).

Wheat (*Triticum* spp.) is a grass cultivated worldwide. Wheat is usually ground to flour which is used to produce a wide range of products. The type of flour produced differs according to the rate of extraction. Wheat grain is a staple food used to make flour, livestock feed and for fermentation to make alcohol. Wheat can be fermented to make beer (<http://www.nutrition.org.uk/upload/Cereals%20pdf.pdf>). The husk can be separated and ground into bran. Wheat is also planted as a forage crop for livestock and the straw can be used as a ruminant feed component or construction material (<http://en.wikipedia.org/wiki/Wheat>).

Maize (or corn, *Zea mays*) is a cereal grain that was domesticated in Mesoamerica. It is called corn in the USA, Canada and Australia, but in other countries that term may refer to other cereal grains (<http://en.wikipedia.org/wiki/Maize>). Hybrid maize is favored by farmers over conventional varieties for its high grain yield. It may be processed to make many different ingredients (e.g. high fructose corn syrup which can be used as an alternative to sucrose derived from sugar cane and sugar beet) and food products. Its germ is rich in oil and can be refined to produce corn oil (<http://www.nutrition.org.uk/upload/Cereals%20pdf.pdf>). Finally, maize is one of the first crops for which genetically modified varieties make up a significant proportion of the total harvest.

Rice is a dietary staple of more than half of the world's human population (most of Asia and Latin America), making it the most consumed cereal grain. Rice cultivation is well suited to countries and regions with low labor costs and high rainfall, as it is very labor-intensive to cultivate and requires plenty of water for irrigation. However, it can be grown practically anywhere, even on steep hillsides. Rice is the world's third largest crop, behind maize (corn) and wheat (<http://en.wikipedia.org/wiki/Rice>). Brown rice has its outer husk removed and white rice is milled and polished further to remove the bran and germ.

Barley (*Hordeum vulgare*) is a major food and animal feed crop, a member of the grass family Poaceae (<http://en.wikipedia.org/wiki/Barley>). Barley is mainly sold as pearl barley, which is the whole grain with its husk removed. It is also used in bread (as flour) and ground as porridge in some countries (<http://www.nutrition.org.uk/upload/Cereals%20pdf.pdf>). Barley is used mainly for malting. Malting is the process where the barley grain is germinated thus producing enzymes which convert its starch reserves to sugars, mainly maltose. In animal feed compositions based on barley grain, industrially derived lysine and threonine are added to obtain a balanced nutritional diet. However, the essential amino acids must be added at additional cost. Other non-essential amino acids, such as glutamine and proline, are present in excess in the major storage proteins and create a different problem. These amino acids, when digested by the animal, release non-utilizable nitrogen. This nitrogen is excreted in the urine, creating a significant environmental load, especially on and around pig farms (<http://www.agrsci.dk/afdelinger/>

forskningsafdelinger/gbi/grupper/molekylaer_genetik_og_bioteknologi/cereals). In 2004, barley ranked fourth in area of cultivation of cereal crops in the world (570 000 km²) FAOSTAT (<http://en.wikipedia.org/wiki/Barley>).

Oat (*Avena sativa*) is a species of cereal grain and the seeds of this plant. It is used for food for people and as fodder for animals, especially poultry and horses. Oat straw is used as animal bedding and sometimes as animal feed. Oat straw is also used in corn dolly making and it is the favorite filling for home-made lace pillows (<http://en.wikipedia.org/wiki/Oat>).

Rye is also a crop that has declined in popularity and today is no longer grown on a substantial level. Previously grown as a poor alternative to wheat, its main function was as a fodder crop. The increased production of barley has reduced its importance (<http://www.face-online.org.uk/resources/factsheets/discovering/cereals.doc>). Rye contains a low amount of gluten, thus producing breads with low volume and a dense texture.

The aim of this chapter is to make a comparative and critical presentation of all cereals waste treatment methods in an attempt to disclose the most effective and low cost methods. The treatment methodologies of wheat, corn, rice, barley and oat wastes are summarized in Tables 10.1–10.5.

Treatment methods

Waste treatment techniques are used to alter the physical, chemical or biological character of the waste, to reduce its volume and/or toxicity and to make the waste safer for disposal. Waste treatment may be required for radioactive, hazardous and other Department of Energy (DOE) wastes. However, DOE does not treat all of its wastes. Some solid sanitary waste does not require treatment prior to disposal and hazardous wastes are treated by commercial treatment facilities. Mixed wastes (which contain both hazardous and radioactive components) pose special management challenges since they are difficult to treat with existing treatment technologies (<http://web.em.doe.gov/em30/wasttrea.html>).

Methods of treatment in which the application of physical forces predominate are known as unit operations. Methods of treatment in which the removal of contaminants is brought about by chemical or biological reactions are known as unit processes (Tchobanoglous *et al.*, 2003). The preferred use for surplus straw is as fuel in a suitable on-farm boiler, providing heat for hot water, buildings and grain drying and other operations, thus cutting energy bills and avoiding plowing-in costs. The ash from the boilers can also be used as a fertilizer. Although, there are some problems with drying systems for the straw, control and matching supply and demand. These are not insurmountable and, with current developments in the hardware for drying, the use of straw as a boiler fuel could prove attractive in the future (http://www.biffa.co.uk/files/pdfs/MassBalance_Agriwastes_08_Treatment.pdf). Biological treatment usually involves treatment of waste by bacteria, fungi or algae to remove and degrade the hazardous constituents. A boiler is a type of device that can be used to treat hazardous waste. Boilers use controlled flame combustion and recover thermal energy in the form of steam or heated gases (<http://www.epa.gov/epaoswer/osw/treattech.htm>).

Table 10.1 Treatment methodologies of wheat wastes: parameters, quality control methods and results

No	Kind of waste	Treatment	Parameters	Methodology	Quality control methods	Results	References
1	Wheat straw waste	Vermicomposting	The N, P, K content increased during pre-decomposition with bioinoculants	Wheat straw was predecomposed by inoculating it with <i>Pleurotus sajor-caju</i> , <i>Trichoderma harzianum</i> , <i>Aspergillus niger</i> and <i>Azotobacter chroococcum</i> in different combinations	<ol style="list-style-type: none"> 1 Spectrophotometry for total phosphorus (TP) and total potassium (TK) 2 Cellulose, hemicellulose and lignin were determined with Dutta's method 	<ol style="list-style-type: none"> 1 TOC content decreased from 30.10% to 26.48% during composting and finally to 12.75% during vermicomposting 2 Both pre-decomposition and vermicomposting resulted in a loss of carbon because of mineralization. Cellulose, hemicellulose and lignin decreased 	Anshu <i>et al.</i> , 2002
2	Wheat straw waste	Composting	Temperature, compost pH, weight loss, carbon and nitrogen loss, nitrogen mineralization	Water content was determined by weight loss of compost samples, which were oven dried at 80°C for 24 h	<ol style="list-style-type: none"> 1 Total N and C were measured by an automated N-C analyzer interfaced with an isotope mass spectrometer 2 Analysis for NH₄ and NO₃ content with standard colorimetric methods using flow-injection analysis (FIA) 3 Ammonium with HPLC 4 pH was measured in a solution of compost (20 g fresh weight) and water in a ratio of 1:5 	<ol style="list-style-type: none"> 1 pH varied between 7.6 and 8.9 and the highest values were found after 3–4 weeks 2 After 3 weeks of composting, weight losses are decreased 44–45% of initial weight 3 After 7 1/2 weeks weight losses amounted to 61–63% of initial weight 4 %N increased from 2.8% to 4.6% 	Dresboll <i>et al.</i> , 2005
3	Wheat straw waste	Composting	C-N dynamics in an arable field amended with three types of UWC (green waste and sludge, biodegradable waste and solid waste)	Three types of UWC were applied: i) a bio-waste compost (BIO) resulting from the co-composting of green waste and the source separated organic fraction of municipal waste; ii) a co-compost obtained from a mix of 70% green waste and 30% sewage sludge, on a dry matter basis; iii) a municipal solid waste compost	<ol style="list-style-type: none"> 1 The CERES model 2 Parameter modeling 	<ol style="list-style-type: none"> 1 Simulated N fluxes showed that the organic amendments induced an additional leaching ranging from 1 to 8 kg N/ha/year 2 After 4 years, the composts had mineralized 3–8% of their initial organic N content. Composts with slower N release had higher N availability for the crops 3 CERES could thus be used to aid in selecting the 	Gabrielle <i>et al.</i> , 2005

4	Wheat straw	Pyrolysis, GC, MS of acid-precipitable polymeric lignin (APPL)	Lignin-carbohydrate-protein complexes, phydroxyphenyl: guaiacyl:syringyl and syringil/guaia-cyl (S/G) ratios, NaOH	Wheat straw transformed by the strains <i>Streptomyces</i> UAH 23, <i>Streptomyces</i> UAH 52 and <i>Streptomyces viridosporus</i> T7	<ol style="list-style-type: none"> 1 APPL 2 Pyrolysis 3 GC 4 MC 	<p>timing of compost application, in relation to its stability, based on both environmental and agronomical criteria</p> <ol style="list-style-type: none"> 1 A large number of compounds derived from phenolic lignin units 2 Replicate analysis resulted in standard deviation of 5–10% range for all compounds 	Rodriguez <i>et al.</i> , 1997
5	Wheat straw	NMR, conventional pyrolysis and TMAH thermochemolysis	50:50 cellulose:lignin mixture, ¹³ C	<ol style="list-style-type: none"> 1 10% H₂SO₄ for 0.5 h at 100°C to remove starch, proteins and sugars 2 4 10⁻² M KQH for 24 h at room temperature to remove low molecular weight lignin 3 Washing with dilute HNO₃ 	<ol style="list-style-type: none"> 1 Nuclear magnetic resonance (NMR) spectroscopy 2 Pyrolysis without TMAH 3 TMAH thermochemolysis 	<ol style="list-style-type: none"> 1 The acid and base treatments resulted in the elimination of wheat straw components except the ligno-cellulosic ones and LCS is composed of approximately 85% of cellulose and 15% of lignin 2 TMAH thermochemolysis is more efficient than conventional pyrolysis to produce GC compounds via cleavage of cellulose structure 	Gauthier <i>et al.</i> , 2003
6	Wheat lignin	Pyrolysis, GC, MS	The most noticeable modification was the significant decrease of lignin phenolic content as revealed by Py-GC-MS of methylated straw	Peroxidase is produced by <i>Pleurotus eryngii</i>	<ol style="list-style-type: none"> 1 Pyrolysis 2 The peroxidase treatment modified the molar H:G:S ratio of the etherified moiety 	<ol style="list-style-type: none"> 1 10 U of peroxidase per mg of straw decreased the amount of phenolic H units from 31% in control to 3% in treated straw, that of G units from 40 to 4% and completely removed the small amount of phenolic S units present in wheat straw 2 The same tendency to decrease lignin phenolic content was observed when lower enzyme doses were used 	Camarero <i>et al.</i> , 2001

(Continued)

Table 10.1 (Continued)

No	Kind of waste	Treatment	Parameters	Methodology	Quality control methods	Results	References
7	Wheat straw	Pyrolysis	KCl has a relatively high vapor pressure at the temperature of relevance in combustion	The release of alkali during pyrolysis in the temperature range 25–1060 °C is measured using the sensitive surface ionization technique	Pyrolysis	<ol style="list-style-type: none"> 1 Application of chloride-free fertilizers is concluded to be a simple and efficient way to reduce the alkali release from the fuels 2 The method can easily be combined with other methods in order to improve fuel quality 	Davidsson <i>et al.</i> , 2002
8	Wheat straw	Py:GC:MS	The APPL was precipitated from the supernatants by acidification to pH 1–2 with 12 M HCl	Use of <i>Streptomyces</i> spp. UAH 47	<ol style="list-style-type: none"> 1 Pyrolysis 2 GC 3 MS 	<ol style="list-style-type: none"> 1 Release of ferulic and p-coumaric acid due to respective esterases' action detected with HPLC 2 Straight correlation between the relative areas of the compounds derived from carbohydrates and the pattern of hemicellulolytic and cellulolytic enzymes produced by the strain 	Hernandez <i>et al.</i> , 2000
9	Wheat and corn straw	Pyrolysis	TGA was one of the main techniques for analysis of characteristics of solid fuel volatilization	The heating process consists of fast sample heating (25–70 K/s) to the desired temperature	Pyrolysis kinetics	<ol style="list-style-type: none"> 1 The ratio between the conversion and the heating time varies from a maximum of 1050 (low temperatures) to a minimum of 65 (high temperatures) with the corresponding solid mass fraction at the beginning of the true isothermal stage equal to 0.99 and 0.75 2 The weight loss curves obtained for corn stalks had the same qualitative behavior as wheat straw 	Lanzetta and Di Blasi, 1998
10	Waste paper and wheat	Pyrolysis	Biomechanical pulps, alkaline salts, H ₂ SO ₄	Biomechanical pulping including solid-state	Pyrolysis procedure	The large variety of lignin-derived products: phenol,	Galletti <i>et al.</i> , 1997

	straw pulps			fermentation with the ligninolytic fungi <i>Pleurotus ostreatus</i> and <i>P. floridanus</i>		guaiacol and syringol	
11	Wheat lignin degradation	Pyrolysis	The free phenolic lignin-units were preferentially removed as compared with the etherified ones	Lignin degradation by several white-rot fungi including <i>Pleurotus eryngii</i> , <i>Pleurotus cornucopiae</i> , <i>Pleurotus floridanus</i> , <i>Pleurotus ostreatus</i> , <i>Pleurotus pulmonarius</i> , <i>Pleurotus sajor-caju</i> , and <i>Phanerochaete chrysosporium</i>	1 Analytical pyrolysis 2 GC 3 MS	1 The free phenolic lignin-units (around 50% of the total H and G units and only 6% of S units) were preferentially removed 2 When 50% of wheat lignin degraded by <i>P. eryngii</i> , the relative abundance of aromatic acids was over 15% of the total lignin derived products	Martinez <i>et al.</i> , 2001
12	The effect of fungal decay on wheat straw lignin	Pyrolysis	The presence of tetramethyl ammonium hydroxide (TMAH)	Fungal degradation by <i>Agaricus bisporus</i>	Pyrolysis, GC, MS in the presence of TMAH is a sensitive method for tracking the oxidative degradation of lignin during the fungal decay of wheat straw	The major TMAH thermochemolysis products from undegraded wheat straw consist of methylated syringyl, guaiacyl and <i>p</i> -hydroxy-phenyl derivatives	Vane <i>et al.</i> , 2001
13	Wheat straw waste	Combustion	TGA for devolatilization kinetic parameters, chars prepared in a drop-tube were obtained (1273 K, 0% O ₂), particle injection into a stoichiometric air	The temperature is high (ca 1500°C)	The combustion model for experiment was generated using the FG-DVC pyrolysis model	1 The straw devolatilizes more rapidly, produces a higher yield of volatiles (mostly CO and H ₂) and consequently has a shorter ignition delay 2 Straw burning involves extensive devolatilization and, as a consequence, the char burnout of the residue, which is a small quantity, does not play a significant part of the overall processes	Jones <i>et al.</i> , 2000
14	Wheat straw waste	Combustion	Silica (76–83 mol%) and K (11–12 mol%) contained small	Air at 1 atm was carried out at temperatures ranging from 500–1200°C	Combustion of wheat straw	The identification of the probable cause of deleterious effects on the	Blander and Pelton, 1997

(Continued)

Table 10.1 (Continued)

No	Kind of waste	Treatment	Parameters	Methodology	Quality control methods	Results	References
			concentrations (<5 mol%) of Ca, Na, Mg and Al oxides, small amounts of chloride, sulfate and carbonate			combustion system is an important first step in solving the problems in the combustion of wheat straw	
15	Wheat straw waste	Gasification	Use of CO ₂	Temperature 700–900°C	CO ₂ gasification at 700–900°C in a pressurized TGA at 2×10^5 – 2×10^6 Pa	<ol style="list-style-type: none"> 1 The separation effects of total pyrolysis pressure and total gasification pressure were investigated 2 The variation in reactivity among the four biomasses under equal gasification conditions was investigated and analyzed on the basis of their chemical compositions 	Illerup and Rathman, 1997
16	Wheat straw waste	Gasification	Use of CO ₂ and H ₂ O	The experimental conditions were 10 and 20 bar total pressure, 0.15–1.5 bar H ₂ O and 0–1.0 bar H ₂ and 750–925°C	Steam (H ₂ O) gasification	The variation in reactivity among the four biomasses under equal gasification conditions was investigated and analyzed on the basis of their chemical compositions	Fjellerup <i>et al.</i> , 1996
17	Wheat straw waste	Gasification	Use of CO ₂ and H ₂ O	The composition of H was about 40–50% and gas yields were 150–960 ml/g straw, which is dependent on the gasified temperature	Gasification of wheat straw	Wheat straw was gasified in fixed bed reactor at 700–1000°C with steam to investigate the possibility of a process to convert straw to ammonia synthesis gas	Liu <i>et al.</i> , 2000
18	Wheat waste	Roasting of wheat germ	Commercial plant oils, peroxide value, conjugated diene hydroperoxide concentration and atocopherol concentration,	<ol style="list-style-type: none"> 1 Solvents extracts of roasted wheat germ, an actual waste stream of wheat processing, retarded the autoxidation of corn oil stored at 60°C 	<ol style="list-style-type: none"> 1 Wheat germ roasting 2 Accelerated oxidation tests 	Presence of classes I and II antioxidants in ethanolic AOE of wheat germ	Krings <i>et al.</i> , 2000

19	Biomass residue	Briquetting pressure	high dosages of 20 and 40% AOE	2 Best stabilization of stripped corn oil with ethanolic extract (antioxidative extract, AOE) from wheat germ roasted at 160°C for 20 min	Six different pressures of 300, 400, 500, 600, 700 and 800 MPa	1 The density of biowaste briquettes depended on the density of the original biowaste, the briquetting pressure and, to a certain extent, on the briquetting temperature and time 2 The effect of moisture content of the briquettes was managed through control over machine and mixture factor. The expression of water during briquette formation and compaction depends upon the draining quality of the feed mixture	Demirbas and Sahin, 1998
20	Waste residues of wheat straw	Adsorption	The reactive dyes were Cibacron Yellow C-2R, Cibacron Red C-2G, Cibacron Blue C-R, Remazol Black B and Remazol Red RB	Temperature (80–120°C)	1 Steam pretreatment 2 Alkali pretreatment 3 Ammonia steeping 4 Milling	1 Though the milled, steam and the NaOH treated straw had different C_e values, they had similar dye removal (54%, 56% and 53%, respectively) after 102 h of contact time while the control-substrate removed only 26% of the dyes	Robinson <i>et al.</i> , 2002
21	Wheat straw waste	Composting	NaOH or HCl	Batch tests were carried out to analyze influences of several environmental factors on biohydrogen production from wheat straw wastes	1 HCl pretreated wheat straw 2 Composting	1 The maximum cumulative hydrogen yield of 68.1 ml H_2/g TVS was observed at 126.5 h, the value was about 136-fold as compared with that of raw wheat straw wastes 2 The pretreatment of the substrate played a key role in the conversion of the	Fan <i>et al.</i> , 2005

(Continued)

Table 10.1 (Continued)

No	Kind of waste	Treatment	Parameters	Methodology	Quality control methods	Results	References
22	Wheat as generic feedstock	Chemical production	Bioethanol, amino acids and organic acids, ethylene, propylene, butadiene and their derivatives	The world wheat production was evaluated for the production of major bioproducts	Chemical production	wheat straw wastes into biohydrogen by the composts generating hydrogen <ol style="list-style-type: none"> 1 Production of a liquid stream rich in glucose (320 g/l) and one rich in nitrogen (1.5 g/l) 2 Both streams contained phosphorus, vitamins and trace elements necessary for subsequent fermentation processes 3 This versatile fermentation medium was utilized successfully for the production of ethanol, lactic acid, pigment and glycerol 	Koutinas <i>et al.</i> , 2004
23	Wheat straw waste	Biodegradation	The optimum pH for cellulase production was 5.5	<i>Phanerochaete chrysosporium</i> NRRL 6359, <i>P. chrysosporium</i> NRRL 6361 and <i>Coriolus versicolor</i> NRRL 6102	<ol style="list-style-type: none"> 1 Enzyme determination 2 Protein determination 	<ol style="list-style-type: none"> 1 <i>Phanerochaete chrysosporium</i> NRRL 6359 was selected as a better producer for release reducing sugars 2 The highest levels of xylanase, glucanase and cellulase were detected in culture <i>P. chrysosporium</i> NRRL 6359 after 48 h 	Abd El-Nasser <i>et al.</i> , 1997
24	Wheat straw waste	Combustion	21% O ₂ in a balance of N ₂ , CO ₂ , NO _x , SO ₂	Dried wheat straw was incinerated at 800°C in a modified muffle furnace	<ol style="list-style-type: none"> 1 GC 2 Combustion 3 MS 	<ol style="list-style-type: none"> 1 The product gas resulting from incineration of wheat straw contained organic as well as inorganic constituents 2 The organic compounds identified in the product gas were benzene, toluene and xylene 	Bubenbeim <i>et al.</i> , 1997

25	Wheat straw waste	Composting	Experiments with ¹⁵ N-labeled fertilizer showed that wheat was able to utilize the applied N more efficiently when cultivated in the stable compost	The compost was assumed to provide 10% of its total N for plant growth over the growing season	1 Mature composting 2 Immature composting	3 The inorganic components were CO ₂ , CO, SO and NO _x 1 When 80% of the N was supplied by the fertilizer and 20% by mature compost, higher yields were produced than with the highest recommended fertilizer N application rate 2 Calculation showed that green waste compost actually released only 2% of its total N content to the following crop, accounting for the low yields	Keeling <i>et al.</i> , 2003
26	Wheat straw waste	Enzymic hydrolysis	1% NaOH for 24 h, 0–3% H ₂ O ₂ for 24 h	The entire process was carried out at low temperature (25–40°C) using a low concentration of chemicals	1 Enzymic hydrolysis 2 Mild alkaline pretreatment 3 Oxidative pretreatment	1 Resulting in relatively low cost and waste liquors containing only trace amounts of dangerous pollutants derived from lignin 2 Recovery of cellulose after the double pretreatment reached 90% of that contained in the starting material, with a concomitant 81% degradation of lignin 3 The action of a commercial cellulase on the cellulose obtained produced syrup with a high concentration of reducing sugars (220 mg/ml), of which a large percentage was glucose	Curreli <i>et al.</i> , 1997
27	Wheat straw waste	Multi-enzyme production	CMCase, Fpase, xylanase, amylase and manganese peroxidase	Two microorganisms identified as <i>Cellulomonas</i> A (yellow color) and <i>Cellulomonas</i> B (white)	Multi-enzyme production	1 To determine the optimal temperature for enzyme activities, assay was performed at 20–90°C,	Emtiazi and Nahvi, 2000

(Continued)

Table 10.1 (Continued)

No	Kind of waste	Treatment	Parameters	Methodology	Quality control methods	Results	References
				color), isolated from silkworm and rabbit waste		pH 6.0, except for cellobiase assays, which were conducted at pH 5.5 2 Assays for optimal pH were performed at 50 or 45°C for F _{pase} in the pH range 2.5–9.0	
28	Wheat straw waste	Irradiation and chemical treatment	HBr 47% and NaOH: 0, 3, 6 ml HBr and 3, 6 g NaOH in 25 ml water/100 g DM	1 Samples of wheat straw wastes were dried outdoors for 5 days and then each sample mixed thoroughly 2 Samples were sprayed with different amounts of hydrobromic acid and sodium hydroxide	1 Low gamma irradiation 2 Chemical treatment	1 Chemical treatments increased the <i>in vitro</i> organic matter digestibility (IVOM) and metabolizable energy (ME) values significantly for all samples treated 2 No significant effect of irradiation on IVOMD and ME 3 Combined treatments of irradiation and HBr or NaOH were found ineffective in increasing the IVOMD and ME values	Al-Masri, 2004
29	Wheat straw waste	Enzyme activity	Moisture content of 74%, pH range of 4.5–5.5 on mixed substrate containing wheat straw, wheat bran of 9:1	The organism used in this study was <i>Aspergillus niger</i>	Endoglucanase production	1 An increase in initial moisture content of the substrate from 55 to 74% greatly enhanced the enzymatic activity of the broth 2 It was found that maximum activity was obtained when the initial pH was adjusted to 4.5–5.0 3 The temperature did not affect strongly the enzyme production	Jecu, 2000

Adapted from Arvanitoyannis and Tserkezou, 2007a,b

Table 10.2 Treatment methodologies of corn wastes: parameters, quality control methods and results

No	Kind of waste	Treatment	Parameters	Methodology	Quality control methods	Results	References
1	Corn waste	Composting	Changes characterization in C and N isotope during composting	Compost pH measured in 1:2 slurry of 25 g compost and water	Composting	<ol style="list-style-type: none"> 1 Changes in carbon, nitrogen, $\delta^{13}C$ and $\delta^{14}N$ content during composting 2 Highly recalcitrant composts with prolonged C storage in non-mineral soil fractions 3 The sensitivity of the natural abundance tracer technique to characterize their fate in soil improves during composting, as a more homogeneous C isotope signature develops, in addition to the relatively large amounts of stable C applied in composts 	Lynch <i>et al.</i> , 2006
2	Corn cob waste	Chemical activation	Chemical activation with $ZnCl_2$	500°C was found to be the optimal temperature for producing high surface area carbons with $ZnCl_2$ activation	<ol style="list-style-type: none"> 1 Pyrolysis 2 Zinc chloride activation 	<ol style="list-style-type: none"> 1 Activated carbons yield varied in the range of 27-30.4% 2 The surface areas of the resulting activated carbons, increased rapidly with impregnation ratio of $ZnCl_2$ 3 The $ZnCl_2$ activation of corn cob was suitable for the microporous activated carbons preparation 	Tsai <i>et al.</i> , 1998
3	Corn stalk waste	Pyrolysis	TGA	Materials were rapidly heated to high temperatures in the absence of air (oxygen)	<ol style="list-style-type: none"> 1 Flash pyrolysis (FP) 2 Plasma heated laminar entrained flow reactor (PHLEFR) 3 Thermolysis 	Yields of volatile pyrolysis products depended on the final pyrolysis temperature and residence time	Shuangninga <i>et al.</i> , 2005

(Continued)

Table 10.2 (Continued)

No	Kind of waste	Treatment	Parameters	Methodology	Quality control methods	Results	References
4	Corn straw waste	Pyrolysis	TGA	The heating process consisted of rapid sample heating (25–70 K/s) to the desired temperature	Pyrolysis kinetics	<ol style="list-style-type: none"> The ratio between the conversion and heating time varied from a maximum of about 1050 (low temperatures) to a minimum of about 65 (high temperatures) with the corresponding solid mass fraction at the beginning of the true isothermal stage equal to 0.99 and 0.75 The weight loss curves obtained for corn stalks had the same qualitative behavior as wheat straw 	Lanzetta and Di Blasi, 1998
5	Corn cob waste	Pyrolysis	H ₂ , CH ₄ , CO, CO ₂ and C ₂ H ₂ (for analysis), CH ₄ , C ₂ H ₆ , C ₃ H ₈ and C ₃ H ₆ (for flame ion detector, FID)	<ol style="list-style-type: none"> The corn cob was first placed in the reactor, then nitrogen passed through the reactor with a flow of 80 ml/min The reactor is heated to 110°C at a heating rate of 10 K/min and held the temperature for 1 h in order to remove the water 	<ol style="list-style-type: none"> Pyrolysis GC MS 	<ol style="list-style-type: none"> The experiments showed the higher the temperature, the greater the yield of emitted gases and lesser the amount of the liquid and the solid residue Beyond 400°C, only a part of the components decomposed and exhibited a slower weight loss 	Cao <i>et al.</i> , 2004
6	Corn stover waste	Pyrolysis	Analytical system to determine yield parameters apart from H ₂ O, CO, CO ₂ and H ₂ , the products were divided into paraffins, olefins, alcohols, aromatics etc.	Corn stover, the leaves and stalks usually left in the field after corn harvest, can serve as a representative biomass feedstock	Pyrolysis	ASEM provides a simple and useful way of distilling the essence of the observed thermochemical response of corn stover to temperature and heating rate	Green and Feng, 2006
7	Corn cob waste	Gasification	Activation temperature ranges	True density and porosity increase with	Gasification of corn cob	<ol style="list-style-type: none"> Comparison of physical characterizations of the 	Tsai <i>et al.</i> , 2001

			of 500–800°C with less pollution characteristics of KOH: K ₂ CO ₃) as chemical agents	increase in the activation temperature		carbon products with those of commercial activated carbons indicated that the activated carbons prepared from agricultural waste corn cob by using a cleaner process is an available route for the biomass utilization and bioresource recycling	
8	Corn starch waste	Gasification	KHCO ₃ was added to the mixture of starch and water before the gel formation	The influence of pressure, temperature, residence time, and alkali addition on the gasification of corn starch showed an improvement	Gasification of corn starch	<ol style="list-style-type: none"> 1 Increase in temperature improved the biomass conversion 2 Longer residence time 	D'Jesus <i>et al.</i> , 2006
						<ol style="list-style-type: none"> 3 in gasification yield until a maximum was reached 4 Gas composition changed with residence time and temperature 5 Potassium addition affected the gasification yield of corn starch 	
9	Corn cob waste	Chemical and physical activation	KOH and K ₂ CO ₃ were effective activating agents for chemical activation during a period of 10°C/min	Subsequent gasification at a soaking period of 800°C	<ol style="list-style-type: none"> 1 Gasification 2 Pyrolysis 	The porosity created in acid-unwashed carbon products is substantially lower than that of acid-washed carbon products due to potassium salts left in the pore structure	Tsai <i>et al.</i> , 2001
10	Corn waste	Combustion and gasification	Removal of carbon from fossil fuels prior to use in energy	Corn refinery industry produces a wide range of products including	<ol style="list-style-type: none"> 1 Biomass combustion 2 Gasification combustion 	<ol style="list-style-type: none"> 1 Green plants developed to produce desired products and energy 	Chum and Overend, 2001

(Continued)

Table 10.2 (Continued)

No	Kind of waste	Treatment	Parameters	Methodology	Quality control methods	Results	References
			production is likely to be far less costly than attempting to remove CO from dispersed sources	starch-based ethanol fuels for transportation		<p>could be possible in the future</p> <p>2 Biological systems can be tailored to produce fuels such as hydrogen</p> <p>3 Policy drivers for increased use of biomass for energy and biobased products are reviewed for their potential contributions for a carbon constrained world</p>	
11	Corn cob and corn tar waste	Combustion	Engine power performance, fuel consumption and CO ₂ , CO, HC and NO	Temperature range from 110 to 220°C	Combustion	<p>1 No significant difference in performance between diesel fuel and mixed fuel</p> <p>2 The mixed fuel operation produced low fuel consumption at the various loadings</p> <p>3 Mixed fuel with 11.7 and 6.6% oil-economizing rate, had better oil-economizing compared to diesel fuel respectively. The mixed fuel showed significant improvement at CO₂ emissions</p>	Zhang and Wang, 2006
12	Corn waste	Combustion	Calcium, Cu, K, Mg, Na, P, S and Zn were recovered with the bomb washings	The procedure involved sample combustion in commercial stainless steel oxygen bomb operating at 25 bar	<p>1 Combustion</p> <p>2 Inductively coupled plasma optical emission spectrometry (ICP-OES)</p>	Most of the element recoveries in the samples varied between 91 and 105% and the certified and determined contents exhibited a fair agreement at a 95% confidence level	Souza <i>et al.</i> , 2002
13	Corn stover waste	Combustion	The fertilization consisted of 168 g N and 90 kg each of P ₂ O ₅ and K ₂ O	To minimize the effect of water in the biomass spectra, each sample was air-dried to less than	<p>1 NIR spectroscopy</p> <p>2 Combustion</p>	<p>1 NIR spectroscopy showed i) a rapid drop in soluble glucan, ii) increase in lignin and iii) increase</p>	Pordesimo <i>et al.</i> , 2005

		equivalents	10% moisture prior to NIR spectroscopic analysis		in xylan		
					2 Since product yield in fermentation-based biomass conversion processes is proportional to the structural carbohydrate content of the feedstock, timing of stover collection and the proportion of anatomical fractions collected affect the quality of corn stover as fermentation feedstock		
14	Corn oil	Biodiesel	Control of HC, CO, NO _x	The engine was fueled with pure marine diesel fuel and blends containing two types of biodiesel, at proportions up to 50%	Biodiesel	1 The two types of biodiesel appeared to have equal performance and irrespective of the raw material used for their production, their addition to the marine diesel fuel improved the particulate matter, unburnt hydrocarbons, nitrogen oxide and carbon monoxide emissions 2 The NO _x emissions were reduced in all cases when the two biodiesel containing fuels were used	Kalligeros <i>et al.</i> , 2003
15	Corn waste	Ethanol and biodiesel production	Production of 1000 l of ethanol from corn	Under relatively high prices for gasoline the costs for using ethanol and biodiesel were much higher per equivalent liter of gasoline	1 Biodiesel 2 Ethanol production	Either the costs for generating ethanol or biodiesel have to be reduced substantially, by e.g. technical change or the price for oil has to increase further before ethanol and biodiesel will become economically competitive	Wesseler, 2006

(Continued)

Table 10.2 (Continued)

No	Kind of waste	Treatment	Parameters	Methodology	Quality control methods	Results	References
16	Corn stover waste	Biodiesel and bioethanol	Soil nitrogen-related burdens (e.g. N_2O , NO_x , NO_3) would be reduced by harvesting corn stover	When corn stover was harvested, ethanol was produced from both corn stover and corn grain and lignin rich fermentation residues from corn stover were utilized to generate electricity and steam, which are used in the ethanol production system	1 Biodiesel 2 Bioethanol	1 Corn stover removal would reduce soil organic carbon accumulation rates, but cultivation of winter cover crops, even with corn stover removal, could increase organic carbon accumulation rates because of increased carbon inputs from winter cover crops 2 Utilization of corn stover and winter cover crops can improve the eco-efficiency of the cropping systems	Kim and Dale, 2005
17	Corn cob waste	Pyrolysis	The gas products were analyzed with GC as CO_2 , CO , H_2 , CH_4 , C_2H_4 , C_3H_6 , C_3H_8 , etc.	The temperature was 350–400°C	1 Pyrolysis 2 GC 3 MS	1 DTG showed that thermal decomposition process involves two steps 2 The heating rate affected both the activation energy of the decomposition reaction, but also the path of the reaction 3 The maximum rate temperature of the decomposition reaction shifted to a higher temperature and the order and activation energy of the total decomposition reaction decreased	Cao <i>et al.</i> , 2004
18	Corn oil	Chemical method	Diene hydroperoxide concentration and α -tocopherol	Corn oil stored at 60°C	1 AOE 2 Gas chromatography	1 The stabilization of stripped corn oil, free from any genuine	Krings <i>et al.</i> , 2000

			concentration as analytical indicators			antioxidant, proves the occurrence of class I antioxidants generated during roasting	
19	Corn waste	Bioremediation	pH was maintained around 7.2–7.5 for 40 days	<i>Mycobacterium smegmatis</i> and <i>M. phlei</i>	<ol style="list-style-type: none"> 1 Anaerobic fermentations 2 Methanogenesis 3 In situ remediation 	<ol style="list-style-type: none"> 1 Bioremediation that includes anaerobic fermentations of wastes to produce methane and hydrogen, the genetics of methanogenesis and in situ remediation of contaminated aquifer systems, landfill leachates and industrial effluents 2 Land application of fermentation by-products and their use in animal feeds 3 Biocatalytic studies of transformations of components of corn 4 Separation and recovery of components by membrane technologies 	Montgomery, 2004
20	Corn cob agrowaste	Chemical activation	Precursor materials are impregnated with chemical agents such as $ZnCl_2$ and H_3PO_4 to inhibit the formation of chars and enhance the yield of the resulting activated C	The higher activation temperature can overcome the drawbacks of a longer period of activation required to attain larger surface area and can offer higher potential to produce activated carbon of greater adsorption capacity from agriculture wastes such as corn cobs	<ol style="list-style-type: none"> 1 Burn-off in gasifying agents at 800 and 900°C 2 Steam activation 	<ol style="list-style-type: none"> 1 BET surface areas of activated carbons after about 71 and 59 wt% burn-off of CO_2 and steam activations at 900°C were 1705 and 1315 m^2/g, respectively, indicating high adsorption capacities 2 Production of high quality microporous activated carbon from corn cob agrowaste using 	Chang <i>et al.</i> , 2000

(Continued)

Table 10.2 (Continued)

No	Kind of waste	Treatment	Parameters	Methodology	Quality control methods	Results	References
21	Corn husks waste	Enzyme preparation	The corn husks were passed through a Hobart chopper, blended with 1.25 M NaOH	An enzyme preparation derived from <i>Aspergillus niger</i> and <i>Trichoderma reesei</i>	Enzymatic saccharification of corn husks	<p>N₂ carbonization followed by physical activation with CO₂ or steam</p> <p>1 The products of the enzymatic reaction were identified as glucose, cellobiose, xylobiose, arabinose and xylose</p> <p>2 Increasing the concentration of corn husks in the reaction mixture adversely affected the production of total and individual soluble sugars</p>	Hang and Woodams, 1999
22	Corn cobs waste	Enzyme preparation	Pretreated with NaOH, followed by 48 h of reaction at 50°C and pH 5	An enzyme preparation derived from <i>Aspergillus niger</i> and <i>Trichoderma reesei</i>	Enzymatic saccharification of corn cobs	<p>1 The products of the enzymatic reaction were identified as glucose, cellobiose, xylobiose, arabinose, and xylose</p> <p>2 Increasing the concentration of corn husks in the reaction mixture adversely affected the production of total and individual soluble sugars</p>	Hang and Woodams, 2001
23	Corn cob waste	Biodegradation	Optimum pH for cellulase production was 5.5	<i>Phanerochaete chrysosporium</i> NRRL 6359, <i>P. chrysosporium</i> NRRL 6361 and <i>Coriolus versicolor</i> NRRL 6102	<p>1 Enzyme determination</p> <p>2 Protein determination</p>	<p>1 <i>Phanerochaete chrysosporium</i> NRRL 6359 was selected as a better producer for release reducing sugars</p> <p>2 The highest levels of xylanase, glucanase and cellulase were detected in culture <i>P. chrysosporium</i> NRRL 6359 after 48 h</p>	Abd El-Nasser <i>et al.</i> , 1997

24	Corn stover waste	Chemical activation	Corn stover transported by pipeline at 20% solids concentration (wet basis) or higher could directly enter an ethanol fermentation plant	Heat loss in a 1.26 m pipeline carrying 2 Mdry tonnes/year is about 5°C at a distance of 400 km in typical prairie clay soils	Saccharification of corn stover	<ol style="list-style-type: none"> 1 Transport of corn stover in multiple pipelines offers the opportunity to develop a large ethanol fermentation plant, avoiding some of the diseconomies of scale that arise from smaller plants whose capacities are limited by issues of truck congestion 2 Saccharification in the pipeline would reduce the need for investment in the fermentation plant, saving about 0.2 cents/l of ethanol 	Kumar <i>et al.</i> , 2005
25	Corn cob waste	Hydrolysis	The enzymatic hydrolysis was carried out using citrate buffer (50 mM, pH 4.5) at 52–53°C for different time intervals	Use of <i>Apergillus</i> spp.	<ol style="list-style-type: none"> 1 Enzymatic hydrolysis 2 The hydrolysis products were analyzed by HPLC 	<ol style="list-style-type: none"> 1 Xylose was found to be the major end product with traces of xylobiose and xylotriose at the beginning of hydrolysis 2 Corn cob powder showed lower extent of hydrolysis when treated with higher enzyme concentrations for longer periods of time 	Gokhale <i>et al.</i> , 1998
26	Corn stover waste	Radiation	Gamma irradiation of corn stover in combination with sodium hydroxide for bioconversion of polysaccharide into protein by <i>Pleurotus</i> spp.	<i>Pleurotus ostreatus</i> and <i>P. eous</i> are macrofungi which utilize polysaccharides	Gamma radiation	After the heat/radiation treatment, succession of residual microorganism in the compost could influence the bioconversion of the substrate to utilizable nutrients for the mushroom development	Gbedemah <i>et al.</i> , 1998
27	Corn hull and corn stover waste	Physical activation	The usual commercial choices of activation gas are steam, CO ₂ , air or their mixtures. CO ₂ and O ₂	Temperature control for the reactor consisted of a three-zone temperature control system	Physical activation	<ol style="list-style-type: none"> 1 Both surface area and nature of porosity were significantly affected by the conditions of activation, 	Zhang <i>et al.</i> , 2004

(Continued)

Table 10.2 (Continued)

No	Kind of waste	Treatment	Parameters	Methodology	Quality control methods	Results	References
						<p>the extent of which depended on the nature of precursors</p> <p>2 The higher the activation temperature, the greater are the surface areas and micropore volumes of the resultant activated carbons</p> <p>3 Various precursors were affected differently by the duration of activation</p> <p>4 For oak, the longer the duration of activation, the greater the adsorption capacity of resultant activated carbons, and vice versa for corn hulls and corn stover</p>	
28	Corn cob waste	Chemical activation	Chemically activated method with solution of KOH and soap which acted as surfactant	The temperature varies within 450 and 850°C.	Chemical method	<p>1 The specific surface area (SSA) of activated carbon from corn cobs reached 2700 m²/g</p> <p>2 And the addition of the soap as surfactant may shorten the soaking time</p> <p>3 The structure of the activated carbon prepared had narrow distribution of pore size and the micropores accounted for 78%</p> <p>4 Easy and feasible method</p>	Cao <i>et al.</i> ,

Adapted from Arvanitoyannis and Tserkezou, 2007a,b

Table 10.3 Treatment methodologies of rice wastes: parameters, quality control methods and results

No	Kind of waste	Treatment	Parameters	Methodology	Quality control methods	Results	References
1	Rice straw	Composting	pH 7, the addition of compost (20–200 g/pot) improved selected soil chemical (increased total N, total C and CEC)	The composts reached maturity in 90 days	Composting	<ol style="list-style-type: none"> Benefit of compost without chemical fertilizer demonstrated the validity and possibility of sustainable agronomic performance of faba bean using locally available recycled organic materials The total organic C concentration declined slightly for all mixtures during composting Compost N increased with increasing amounts of oilseed rape cake and poultry manure in the feedstocks 	Abdelhamid <i>et al.</i> , 2004
2	Rice straw	Composting	TKN, TOC and OM and humic substance (HS)	Psychrophilic and mesophilic microorganisms	Anaerobic composting	<ol style="list-style-type: none"> As a result of biodegradation of organic compounds, the temperature increased and reached 40–50°C pH tended to be stable and appeared to be consistent in all the composts 	Zhu, 2007
3	Rice flakes	Composting	The production media contained 5 g of solid substrate and 10 ml mineral solution containing (mg/gds) (NH ₄) ₂ SO ₄ 4, MgSO ₄ 7H ₂ O 1, FeSO ₄ 7H ₂ O 0.02, K ₂ HPO ₄ 1.4 and KH ₂ PO ₄ 0.6, in 250 ml Erlenmeyer flasks initially maintained at pH 7	<i>Aspergillus</i> spp.	Composting	<ol style="list-style-type: none"> Organic nitrogen supplementation showed a higher enzyme production compared to inorganic source Optimum enzymatic activity was observed at 55°C, pH 5 Enzyme activity was enhanced in the presence of calcium, whereas presence of EDTA gave reverse effect 	Anto <i>et al.</i> , 2006
4	Rice straw	Composting	The moisture content (oven dried at 105°C for 24 h), total organic matter (weight loss on ignition at 550°C for 72 h), oxidizable organic carbon (Walkley-Black method) and total	The respiration activity of microorganism was determined on different initial C/N (17, 24 and 40) raw materials	Composting	Straw residues from rice cultivation are rich in organic matter content (80%) and oxidizable organic C (34%) and have a high C/N ratio (very variable and near the average of 50), which means a feasible carbon source for the microorganisms which are able to survive the composting conditions	Iranzo <i>et al.</i> , 2004

(Continued)

Table 10.3 (Continued)

No	Kind of waste	Treatment	Parameters	Methodology	Quality control methods	Results	References
			nitrogen (Kjeldahl method) were determined				
5	Rice straw	Pyrolysis	Oxygen content of the bio-oils was significantly reduced due to the evolution of catalytic gases such as H ₂ O, CO and CO ₂	Pyrolysis temperature, heating rate and holding time on the yields of pyrolysis products and their chemical compositions	1 Fast pyrolysis 2 GC 3 MS	1 The total yield of liquid products significantly increased when pyrolysis temperature was raised from 400 to 500°C 2 The high water content in the pyrolysis liquid product may be due to the high moisture content in the feeding biomasses and the release of volatile organic products during the preparation of condensed liquid sample	Tsai <i>et al.</i> , 2006
6	Rice husk	Pyrolysis	Weight loss curves for pyrolysis of rice husk under N ₂ and CO ₂ atmospheres	Different levels of temperature	Rice husk pyrolysis	The method predicted satisfactorily the pyrolysis data at different heating rates of rice husk	Sharma and Rao, 1999
7	Rice husk	Pyrolysis	Gravimetric determination of SiO ₂ in solid residue	Non-isothermal heating in air	Pyrolysis	1 The burning of rice husk produces SiO ₂ with globular structure and well developed specific area 2 The pyrolysis in nitrogen medium gave SiO ₂ mixed with carbon	Vlaev <i>et al.</i> , 2003
8	Rice husk	Pyrolysis	The spectrum of catalyzed samples with FeCl ₂ ·4H ₂ O.	Temperature, pyrolysis time, type of catalyst and process atmosphere	Pyrolysis	1 The optimized production process was developed using as a FeCl ₂ ·4H ₂ O catalyzer, 1370°C as process temperature, 1.5 l/min argon flow and 40 min residence time 2 Alternative uses for the rice husk were generated as new products that are manufactured from a remainder material	Martinez <i>et al.</i> , 2005
9	Rice straw	Pyrolysis	Nitrogen was used as sweeping gas with the flow rates of either 50, 100, 200 and 400 ml/min and the highest bio-oil yield was	Pyrolysis temperature, particle size, sweeping gas flow rate and steam velocity	1 Pyrolysis 2 GC 3 MS	1 The pyrolysis oils were conducted with H-NMR, oils and aliphatic subfractions with FT-IR 2 The chemical characterization showed that the oil obtained from rice straw may be potentially	Putun <i>et al.</i> , 2004

10	Rice husk and straw	Combustion	obtained when flow rate was 200 ml/min The main element in rice husk ash is silicon (87.7% as SiO ₂), followed by potassium (5.4% as K ₂ O) and phosphorus (3.7% as P ₂ O ₅)	Normal temperature	Combustion	valuable as fuel and chemicals feedstocks 1 The combustion tests using rice husk as fuel were done using different furnace temperatures and fluidization velocities 2 The effect of these variables on combustion efficiency, CO emissions and ash characteristics were studied 3 The combustion tests were operated in the temperature range of 840–880°C and in the fluidization velocity range of 1–1.2 m/s	Armesto <i>et al.</i> , 2002
11	Rice husk	Combustion	CO emissions vary from 200 to 800 ppm, SO ₂ ranges from 50 to 100 ppm and NO _x ranges from 150 to 220 ppm	The temperature measuring and gas sampling ports are installed at different heights	Combustion	1 The experiments showed that CO emissions varied from 200 to 800 ppm, whereas SO ₂ ranged from 50 to 100 ppm and NO _x ranged from 150 to 220 ppm 2 If the fluidizing velocity grew further, the strong combustion intensity zone will move to the top of the freeboard and increases the losses in unburned combustibles	Fang <i>et al.</i> , 2004
12	Rice straw	Combustion	K and Cl content of <i>Miscanthus</i> and determined that a substantial decline in K and Cl occurred as a result of over-wintering	The available period for mechanized collection of rice straw after the winter period ranges from 0 to 45 days	Thermal conversion	1 The moisture contents were similar to those of rice plants just prior to harvest 2 Results for the subtreatments showed that shielded stubble had significantly higher concentrations of K and Cl than exposed stubble and loose straw, suggesting that the thatching effect of straw did reduce leaching rate	Bakkera and Jenkins, 2003
13	Rice husk	Pyrolysis	Using some carbonates like mixture of sodium carbonate and bicarbonate, magnesium carbonate and zinc carbonate	High temperature	Pyrolysis	1 The drastic weight loss pattern observed between 350 and 400°C was due to the destruction of cellulose and hemicellulose in the original biomass 2 Pyrolysis apparently started at 350°C where the volatile	Maiti <i>et al.</i> , 2005

(Continued)

Table 10.3 (Continued)

No	Kind of waste	Treatment	Parameters	Methodology	Quality control methods	Results	
14	Rice husk	Combustion	Both fine carbon/silica and pure silica powders were obtained by carbonization and combustion of rice husk under non-isothermal conditions	Using heating rates of 5, 10, 15, 20°C/min	1 Combustion 2 Carbonization	<p>matter in the biomass began to vaporize</p> <p>3 The yield became almost constant after this stage, which marked the maximum char yield</p> <p>1 After heating the rice husk in N₂ or air, the impurity content was lower than that in acid-leached sample, indicating that the metals were also probably carried out from the volatiles during thermal decomposition</p> <p>2 By comparing the carbon/silica molar ratio in the carbonized husk, it was found that the carbon/silica molar ratio increased with increasing heating rate</p>	Liou, 2004
15	Rice husk	Combustion	Sulfur and nitrogen contained in the liquid fuel are tested to be 0.1% and 0.2% for rice husks	Temperatures between 420 and 540°C	1 Combustion 2 GC 3 MS	<p>1 Experiments showed that a temperature below 420°C was not sufficient for pyrolysis as some rice husks or sawdust were found in the charcoal and ash</p> <p>2 The data showed that: i) the energy cascade is about 49% for liquid fuel and about 86% for all products, ii) the thermal energy contained in the charcoal is more than the energy consumed by electric heating</p>	Zheng <i>et al.</i> , 2006
16	Rice straw	Biogasification	Ammonia was used as a supplemental nitrogen source for rice straw digestion	Mechanical, thermal and chemical (ammonia) treatment	1 Biogasification 2 Anaerobic digestion	<p>1 A combination of grinding (10 mm length), heating (110°C) and ammonia treatment (2%) resulted in the highest biogas yield, 0.47 l/g VS-fed, which is 17.5% higher than the biogas yield of untreated whole straw</p> <p>2 Pretreatment temperature had a significant effect on the digestibility of straw</p>	Zhang and Zhang, 1999

17	Rice straw	Biogas	Disinfection of straw and manure by means of 0.1% KMnO ₄ plus 2% formalin solution in hot water	<i>Pleurotus sajor caju</i>	Biogas	Supplementation of rice straw with biogas residual slurry manure had strong impact on improving the yield potential, protein and mineral nutrient contents of <i>Pleurotus sajor caju</i> mushroom in Indian subcontinent or similar climatic conditions	Banik and Nandi, 2004
18	Rice husk	Gasification	The infrared band intensity of CO ₂ gas was starting to grow at 200–300°C, indicating an oxidation reaction occurred while CO gas was detected at 450°C	Temperature below 730°C to produce syngases for power generation and to recover valuable amorphous silica materials	1 Pyrolysis 2 Gasification 3 Steam gasification	1 Gasification of rice husk was accompanied by a substantial production of syngas at 450–630°C 2 To generate 10 kW electric power, approximately 28 kg of rice husk must be gasified 3 The rice husk gasification process, in terms of heat requirements, can be self-sustaining	Lin <i>et al.</i> , 1999
19	Rice husk	Gasification	Using a gasifying medium such as air, oxygen, steam	High temperature	Air gasification	1 The higher heating value of the gas obtained at this fluidization velocity and equivalence ratio (3.09–5.03 MJ/Nm ³) compared very well with published data from air-blown biomass gasifiers of similar scale of operation 2 The gas yield and carbon conversion were in the range of 1.30 to 1.98 Nm ³ /kg and 55 to 81%, respectively	Mansaraya <i>et al.</i> , 1999
20	Rice husk	Gasification	CO ₂ was introduced by replacing N ₂ gas	Different levels of temperature	Steam gasification	At the higher temperature of 900°C, the reaction mechanism was not only chemically controlled but also influenced by diffusional resistance	Bhat <i>et al.</i> , 2001

Table 10.4 Treatment methodologies of barley wastes: parameters, quality control methods and results

No	Kind of waste	Treatment	Parameters	Methodology	Quality control methods	Results	References
1	Barley waste	Composting	Total nitrogen content, inorganic nitrogen, potassium, phosphorus	Moisture was determined by drying at 105°C for 24 h, and total organic matter content (TOMC) determined by weight loss on ignition at 540°C for 16 h	1 Composting 2 UV-VIS spectrophotometry 3 Vermicomposting	1 Barley wastes showed a high organic matter content (86.27% on dry weight basis, respectively) and are deficient in nitrogen 2 Available phosphorus increased during the composting	Guerra-Rodriguez <i>et al.</i> , 2000
2	Barley straw waste	Composting	Acid and alkaline phosphomonoesterase (PME) and b-D-glucosidase	A fresh compost sample (0.5 g) was mixed with 2.5 ml of 62.3 mM p-nitrophenyl phosphate or 59.9 mM p-nitrophenyl-b-D-glucopyranoside in a modified universal buffer pH 5.0, 9.0 and 6.0, respectively	Composting	The choice of bulking agent strongly affected the potential capacity for mineralization of organic phosphorus in manure composts, but did not affect glucosidase activity (decomposition of cellulosic plant materials like straw)	Vuorinen, 2000
3	Barley straw waste	Composting	Dehydrogenase activities decreased in mature composts to the final constant level of 4.44–5.43 $\mu\text{M TPF/g (dw)}^3/\text{h}$	Heterotrophic mesophilic bacteria	Composting	1 During composting, the C/N ratio decreased from 22.6–28.5 to 12.7–13.6 2 Approximately 11–27% of the total C was lost during 7 days active composting and 62–66% during the whole composting time; the respective gaseous losses of N were 13–23% and 23–37% of the total N	Vuorinen and Saharinen, 1997
4	Barley straw waste	Gasification	Use of CO ₂ and H ₂ O	Experimental conditions: L-10 bar total pressure, 0.15–1.5 bar H ₂ O and 0–1.0 bar H ₂ and 750–925°C	Steam (H ₂ O) gasification	The variation in reactivity among the four biomasses under equal gasification conditions was investigated and analyzed on the basis of their chemical compositions	Fjellerup <i>et al.</i> , 1996

5	Barley straw waste	Gasification	Use of CO ₂	Temperature 700–900°C	CO ₂ gasification at 700–900°C in a pressurized thermogravimetric analyzer at 2–20 bar	The separation effects of total pyrolysis pressure and total gasification pressure were investigated	Illerup and Rathmann, 1997
6	Barley waste	Biogas	The pH was adjusted to 7 and 0.75 g NaHCO ₃ /gTS _{initial}	<ol style="list-style-type: none"> 1 The pH adjusted to 7.0–7.2 2 The handheld pressure transducer used measured a pressure change of two atmospheres (0–202.6 kPa) over a range of –200 to +200 mV 	<ol style="list-style-type: none"> 1 Biogas 2 Alkaline hydrolysis 	<ol style="list-style-type: none"> 1 Co-digestion of the BW with the kitchen waste was beneficial compared to co-digestion with sewage sludge 2 Methane production increased from 25 to 363 LCH₄(STP)/kgVS_{initial} and the total and volatile solids reduction increased from 31% to 61% and from 40% to 67%, respectively 	Neves <i>et al.</i> , 2006
7	Barley husk waste	Adsorption	The removal of dyes (Cibacron Yellow C-2R, Cibacron Red C-2G, Cibacron Blue C-R, Remazol Black B and Remazol Red RB)	Temperature (80–120°C)	<ol style="list-style-type: none"> 1 Steam pretreatment 2 Alkali pretreatment 3 Ammonia steeping 4 Milling 	<ol style="list-style-type: none"> 1 Though the milled, steam and the NaOH treated straw had different Ce values they had similar dye removal (54%, 56% and 53%, respectively) after 102 h of contact time while the control-substrate removed only 26% of the dyes 2 All straw pretreatments were effective at increasing the amount of dye adsorbed per gram of substrate 	Robinson <i>et al.</i> , 2002
8	Barley husk waste	Adsorption	At total dye concentrations of 10, 20, 30, 40, 50, 100, 150 and 200 mg/l, experiments were carried out with an artificial effluent of an equal mixture of five textile dyes	Experiments were carried out statically at room temperature, 20 ± 2°C	Adsorption	<ol style="list-style-type: none"> 1 Adsorption of dyes from an artificial effluent onto barley husk was measured for four different initial dye concentrations at an adsorbent dose of 5 g (1 × 4 mm of particle size per 100 ml) 2 Although 5 g of barley husk removed a very high percentage of dyes from the effluent 	Robinson <i>et al.</i> , 2002
9	Barley waste	Composting	0.1 M P ₂ O ₇ Na ₄ at pH 9.8 for 24 h	The maximum temperatures reached were 65–68°C and the humidity level was kept at 45–65%.	Composting	The absorption of micronutrients was favored by the lowest doses while doses above 10 mg C/l inhibited it, which was probably one of the causes of the depressed growth observed with the highest doses	Ayuso <i>et al.</i> , 1996

Table 10.5 Treatment methodologies of oat wastes: parameters, quality control methods and results

No	Kind of waste	Treatment	Parameters	Methodology	Quality control	Results methods	References
1	Oat waste	Pyrolysis	The relative compositions of inorganic (Ca, Mg, and K) and organic (C, N and P) elements in plant residues provide a gross estimate of rates of decomposition	The samples were incubated in the dark at 25°C for 15, 30 and 80 days, dried at 65°C for 72 h and weight losses determined	1 Flash pyrolysis 2 GC 3 MS	The weight losses in this experiment were similar to those reported for black oat litter (53% over 70 days)	Franchini <i>et al.</i> , 2000
2	Alkali release from oat straws	Pyrolysis	Use of Al ₂ O ₃ , Cl	The release of alkali during pyrolysis in the temperature range 25–1060°C was measured using the sensitive surface ionization technique	Pyrolysis	1 Application of chloride-free fertilizers is concluded to be a simple and efficient way to reduce the alkali release from the fuels 2 The method can easily be combined with other methods in order to improve fuel quality	Davidsson <i>et al.</i> , 2001
3	Oat waste	Pyrolysis	The clay mineralogy is mostly composed of kaolinite (720 g/kg) and iron oxides (109 g/kg)	The temperature is 600°C	1 Flash pyrolysis 2 GC 3 MS	The main representatives of the phenol-derivatives were phenol, 2-methylphenol and 4-vinylphenol and are commonly identified after Py-GC/MS of plant, soil or humic substances samples	Dieckow <i>et al.</i> , 2006
4	Oat waste	Physical activation	Treatment with 0.2 M HCl	The metal binding ability of oat by-products was calculated from experimental data collected at temperatures of 8, 26 and 54°C and time exposures of 1, 6, 24, 48 and 72 h at each temperature	Physical activation	1 The amount of Cr(III) bound to oat biomass increased as the pH increased with a maximum of nearly 90% binding at pH 6, while the maximum binding of Cr(VI) to the oat biomass was nearly 32% at pH 2 2 Temperature may play an important role in the reduction of Cr(VI) to Cr(III) from contaminated waters	Gardea-Torresdey <i>et al.</i> , 2000

Treatment methods are selected based on the composition, quantity and form of the waste material. Some waste treatment methods are prescribed by regulations and DOE Orders; other treatment methods are being developed for specific wastes. Waste treatment methods being used today include solidification (e.g. calcining and vitrification) and volume reduction (e.g. incineration, compaction and sizing). There are two principal types of biological sewage treatment:

- 1 the percolating filter (also referred to as a trickling or biological filter)
- 2 activated sludge treatment.

Both types of treatment utilize two vessels, a reactor containing the microorganisms which oxidize the biochemical oxygen demand (BOD) and a secondary sedimentation tank, which resembles the circular radial flow primary sedimentation tank, in which the microorganisms are separated from the final effluent (Harrison, 2001).

Chemical reduction uses strong reducing agents (e.g. sulfur dioxide, alkali salts, sulfides, iron salts, etc.) to break down hazardous waste constituents to render them less toxic or mobile. Deactivation is a process that removes the hazardous nature of the waste by neutralizing the characteristics of ignitability, corrosivity and/or reactivity. Carbon adsorption uses activated carbon to adsorb hazardous waste constituents. Gaseous and aqueous waste streams can be treated by carbon adsorption. Chemical oxidation uses strong oxidizing agents (e.g. hypochlorite, peroxides, persulfates, perchlorates, permanganates, etc.) to break down hazardous waste constituents to render them less toxic or mobile (<http://www.epa.gov/epaoswer/osw/treattech.htm>).

Solidification is a method for mixing of cement, fly ash from the incinerator and waste filter cake from the physicochemical treatment to form a virtually insoluble mass (http://www.zazemiata.org/bw/radnevo/resume_ovos_en.pdf). Solidification processes such as calcining and vitrification can be used to treat non-solid radioactive waste. DOE processing plants take liquid waste or semisolid sludge and convert it to a solid waste form that can be safely disposed in a geologic repository (<http://web.em.doe.gov/em30/wasttrea.html>). The advantages of this method are in the use of simple equipment and the very inexpensive and flexible operation. This method allows for a high degree of inertness of the waste (http://www.zazemiata.org/bw/radnevo/resume_ovos_en.pdf).

Incineration is the high temperature burning (rapid oxidation) of a waste, usually at 870–1370 °C. It is also known as controlled-flame combustion or calcination and is a technology that destroys organic constituents in waste materials (<http://www.epa.gov/epaoswer/osw/treattech.htm>). Incineration of some commercial and industrial wastes, which are hazardous and have low throughputs, is a means of disposal and energy recovery is often a secondary objective. Sewage sludge incineration generates heat which is often used to dry the input sewage sludge to levels where the combustion is self-sustaining (Williams, 2005). Airborne effluents are carefully processed and monitored for compliance with environmental regulations and permit conditions to ensure safety (<http://web.em.doe.gov/em30/wasttrea.html>).

The activated sludge process may have up to four phases:

- 1 clarification, by flocculation of suspended and colloidal matter
- 2 oxidation of carbonaceous matter

- 3 oxidation of nitrogenous matter
- 4 auto-digestion of the activated sludge (Harrison, 2001).

Neutralization is a process used to treat corrosive hazardous waste streams. Low pH acidic corrosive waste streams are usually neutralized with containing bases. High pH corrosive waste streams are usually neutralized by adding acids (<http://www.epa.gov/epaoswer/osw/treattech.htm>).

An industrial furnace is a type of hazardous waste treatment device that uses thermal energy to recover energy or materials. It includes cement kilns, lime kilns, aggregate kilns, phosphate kilns, coke ovens, blast furnaces, smelting furnaces, etc.

Microencapsulation is a process that coats the surface of the waste material with a thin layer of plastic or resin to prevent the material from leaching hazardous waste constituents (<http://www.epa.gov/epaoswer/osw/treattech.htm>).

Vitrification is a solidification process that combines semi-liquid waste with glass, resulting in a stable glass form. This molten glass is then poured into stainless steel canisters. When the mixture has cooled and hardened into a stable glass the radioactive elements are trapped, thus preventing them from moving through the air or water into the environment (<http://web.em.doe.gov/em30/wasttrea.html>).

The physicochemical treatment plant will neutralize inorganic hazardous waste, including cyanides, chromium waste, waste acids, waste alkalis and heavy-metal containing waste. The main methods used will be cyanide oxidation, chromium reduction with subsequent settling, settling of heavy metals, neutralization of acids and alkalis (http://www.zazemiata.org/bw/radnevo/resume_ovos_en.pdf). Physical removal is a process that removes the hazardous constituents from waste streams by separation techniques such as ion exchange, adsorption, reverse osmosis, chelation, solvent extraction, crystallization, precipitation, distillation, filtration, evaporation, etc. The removed hazardous constituents may require further treatment to make them less toxic.

Steam stripping is a treatment technology mainly applied towards removal of organic compounds from liquid waste streams. The process involves direct application of steam to the liquid and subsequent condensation of the extracted organic compounds. Steam stripping not only removes hazardous constituents from the waste stream but it also can have the added benefit of making the constituents less toxic (<http://www.epa.gov/epaoswer/osw/treattech.htm>). Solid waste reduction, by reducing the volume of waste that requires disposal, means that the DOE can use the existing storage and disposal sites for a longer period of time. Solid waste reduction includes treatment methods that reduce the volume of solid waste such as incineration, compaction and sizing (<http://web.em.doe.gov/em30/wasttrea.html>).

The advantages and disadvantages of the treatment methodologies are given in Table 10.6. A typical wastewater treatment plant flow diagram incorporating flow equalization is presented in Figure 10.1 and from multiple biomass resources to a variety of fuels and energy products in Figure 10.2.

Composting

Composting has long been used for management of manure on farms and is a required practice under organic agriculture production protocols in Canada. The agronomic

Table 10.6 The advantages and the disadvantages of treatment methodologies employed for cereal wastes

Treatment methodologies of cereal wastes	Advantages	Disadvantages
Pyrolysis	<ol style="list-style-type: none"> 1 Uses less oxygen than traditional mass-burn incineration 2 Waste degradation to produce char (or ash), pyrolysis oil and synthetic gas (called syngas) 3 Wastes conversion into energy rich fuels by heating the waste under controlled conditions 4 Oils and solid char from pyrolysis are purified and used as a feedstock for petrochemicals and other applications 	<ol style="list-style-type: none"> 1 High temperature required to break down any waste containing carbon 2 Difficult to transfer heat to feedstock 3 Undermining of recycling 4 Not economically attractive
Gasification	<ol style="list-style-type: none"> 1 Hydrocarbons left into a syngas are broken down using a controlled amount of oxygen 2 Wastes conversion into energy rich fuels by heating the waste under controlled conditions 3 Gasification in conjunction with gas engines obtains higher conversion efficiency than conventional fossil-fuel energy generation 4 Production of nitrogen-free gas 5 Operation at a lower temperature and wider variety of feedstocks than direct combustion systems 	<ol style="list-style-type: none"> 1 High temperatures required to break down any waste containing carbon 2 Not economically attractive 3 Similar to incineration and as a result of negative public perception this can lead to planning problems 4 Gasification may inhibit waste minimization and recycling 5 Small amounts of released tar in the gas coats parts of the pipe or the equipment
Composting	<ol style="list-style-type: none"> 1 Improved soil structure, increased water-holding capacity, improved root and plant growth and reduced wind and water erosion 2 Improvement of manure properties for organic farming 	<ol style="list-style-type: none"> 1 Time-consuming process 2 Nitrogen considered a limiting factor for microbial growth and activity during the decomposition of plant residues
Combustion	<ol style="list-style-type: none"> 1 Combustion in premixed gaseous mixtures often produces interesting structure 2 High softening, hemispherical and flow temperatures are considered to be advantageous 	<ol style="list-style-type: none"> 1 High temperature required high cost 2 High pressure application required high cost
Biogas	<ol style="list-style-type: none"> 1 Biogas is about 20% lighter than air 2 Odorless and colorless gas 	<ol style="list-style-type: none"> 1 Biogas ignition temperature in the range of 650–750 °C

value of compost and its beneficial or detrimental effects on soil and the environment are closely linked to the nature and dynamics of its constituent organic matter (Lynch *et al.*, 2006).

Composting is decomposition of the organic, biodegradable fraction of waste to produce a stable product such as soil conditioners and growing material for plants. Composting of garden and food waste has been recommended to home-owners as a direct way of recycling. It has been extended on a larger scale for green waste from parks and gardens and also to municipal solid waste and to sewage sludge. The quality of the compost produced from waste, compared with non-waste sources, has been an issue for waste composting, particularly in the area of contamination (Williams, 2005). Compost was found to improve soil structure and organic matter content and nutrient supply to plants and thus may reduce the input of mineral fertilizers in

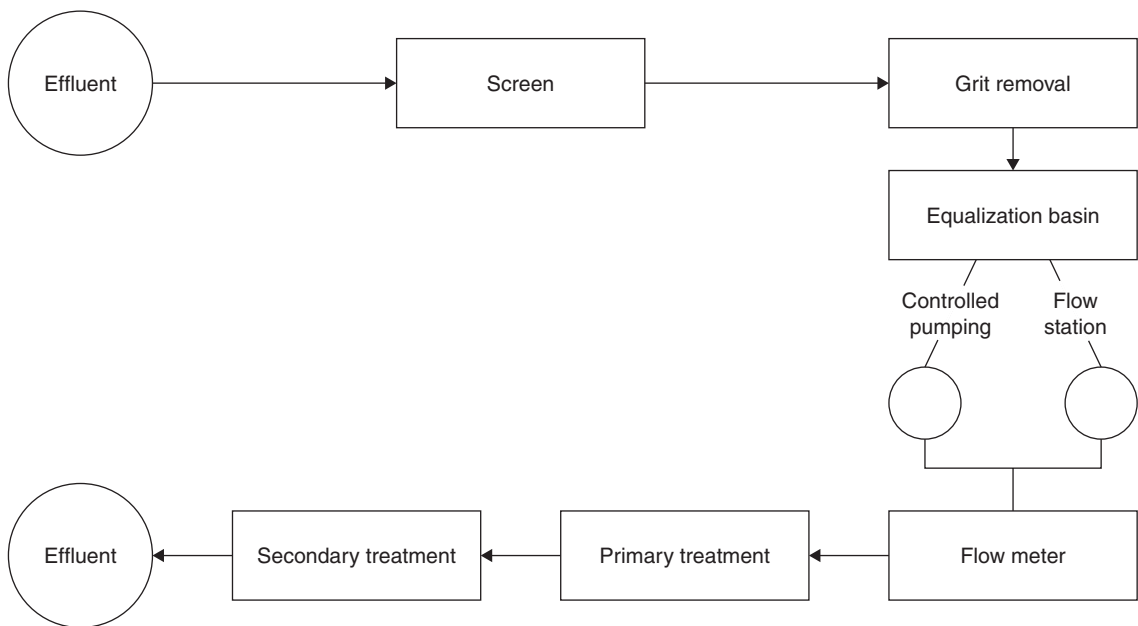

Figure 10.1 Typical wastewater treatment plant flow diagram incorporating flow equalization (adapted from Tchobanoglous *et al.*, 2003)

conventional agriculture and provide a useful nutrient source in organic farming, respectively. To integrate compost into the crop rotation, the availability of the nutrients should be known (Erhart *et al.*, 2005).

The composting process is aerobic and consequently relies on a plentiful supply of oxygen. Regular aeration is required to maintain aerobic conditions. The composting process may be characterized by three stages. The first stage is characterized by increasing temperatures and involves a high rate of microbiological activity. Simple carbohydrates and proteins are readily biologically degraded by mesophilic microorganisms, followed by thermotolerant and thermophilic microorganisms as the temperature rises above 45 °C (Swan *et al.*, 2002). The second stabilization stage involves biodegradation of the waste by thermophilic microorganisms and is an exothermic process where temperature in the compost pile can reach up to 70 °C, so that only the most temperature resistant microorganisms survive. The high temperature stage involves the thermal destruction of weed seeds and pathogenic microorganisms. In the third stage, the material continues to cool and microorganisms begin to compete for the remaining organic material, in turn leading to breakdown of cellulose and lignin in the waste (Harrison, 2001).

Composting is commonly used to improve the properties of manures for organic farming. Available N in raw manure is immobilized during optimal composting allowing more stable slow release of N forms for crops. Nutrient losses during composting can be minimized by good, optimized process handling and use of suitable bulking agents, thus improving the fertilization value of manure. Therefore, during manure

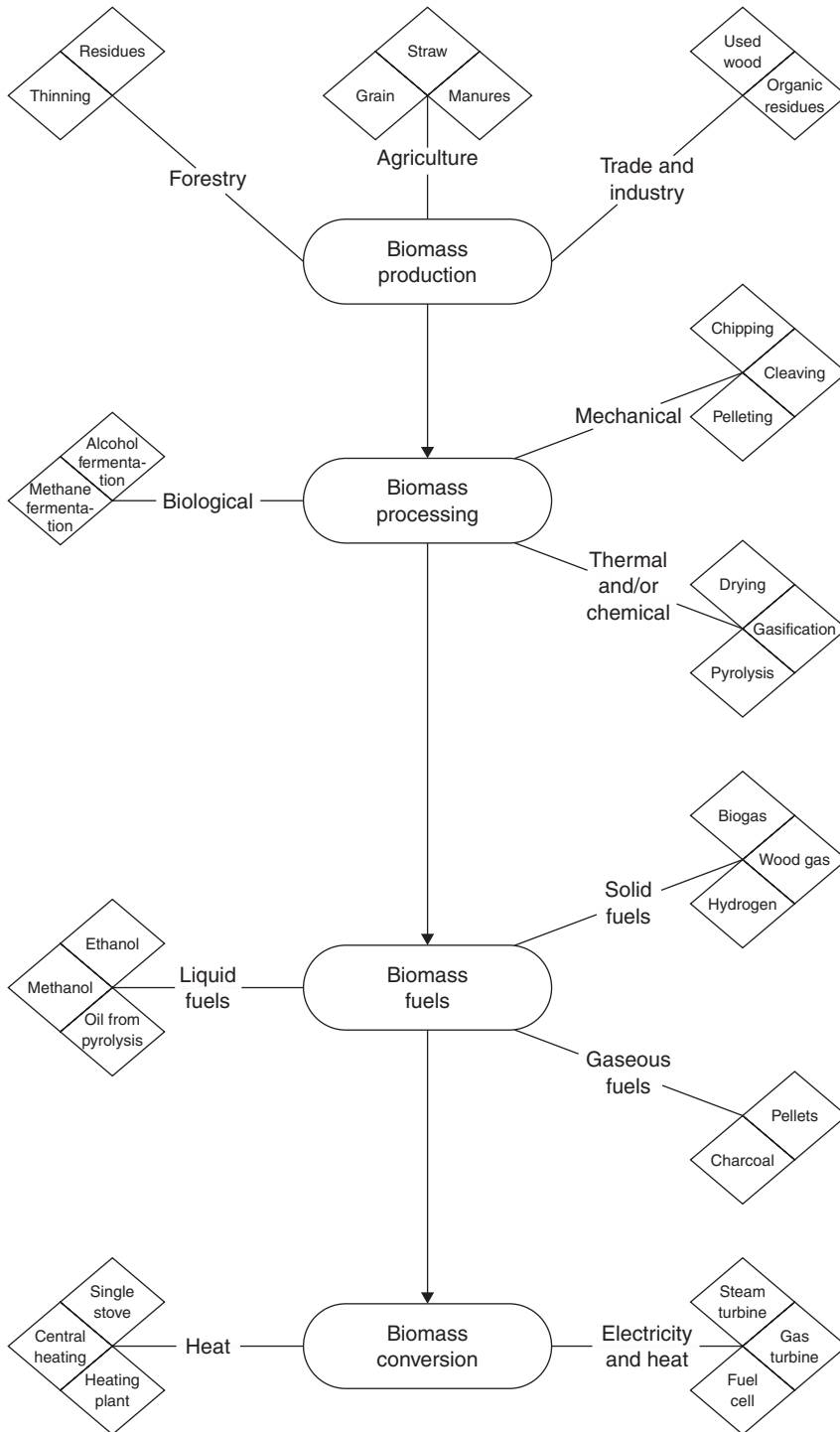

Figure 10.2 From multiple biomass resources to a variety of fuels and energy products (adapted from Chum and Overend, 2001)

composting and application of composted manures, the environmental risks, such as ammonia volatilization and leaching of N and P, may be less than when raw or anaerobically stored manures are handled or during improper handling of manure (Vuorinen Saharinen, 1997). High quality compost is increasingly available and it offers farmers considerable benefits when used on land in a way that other materials, whether conventional fertilizers or wastes such as sludges, do not. Good quality compost is a valuable and safe resource, not a waste product. As a general principle, all material, such as compost that has significant fertilizer value, should be applied only up to the level of crop requirements. However, the way in which compost can be used is different when compared to mineral fertilizers. To identify the use thresholds it is important to understand the nature of compost (http://www.remade.org.uk/organics/organics_documents/compostbenefitsscottishcrops.pdf).

Turning compost is important as it ensures proper mixing, wetting, aeration and decomposition. Materials at the bottom are then placed at the top of the heap. It is recommended to sprinkle 20 liters of water on the heap during turning, particularly when conditions are dry. Compost turning is continued until the heaped materials turn dark gray. Biological activity is periodically monitored by pushing a stick into the middle and sides of the stack. Composting requires 4 to 6 months and, at maturity, about 1900 kg of fortified compost is produced (<http://www.formatkenya.org/orinbook/Chapters/chapter9.htm>).

Since much carbon (C) from plant residues such as straw materials is only slowly available to microorganisms, leading to low growth efficiency, a limited amount of nitrogen (N) may be required during decomposition and recycling of N may then be adequate to meet the N requirements. Microorganisms, especially fungi, have a considerable capacity to adapt to N deficient conditions. A large amount of N initially could consequently result in immobilization. This greater N immobilization may depend on:

- 1 synthesis of microbial biomass with a lower C/N ratio
- 2 higher N losses
- 3 reduced N mineralization or re-mineralization, which may have been related to reduced microbial activity (Dresboll and Thorup-Kristensen, 2004).

Amidst the range of waste treatments currently available, incineration and landfilling are the most frequent and are commonly combined to meet the needs of local communities. Composting of urban waste has emerged as a valuable alternative because of the high proportion of organic matter in urban waste. The biodegradable fraction is estimated at about 25% (fresh weight) in France, along with an additional 25% made up of paper and cardboard. Composts have long been used in agriculture and urban waste composts (UWC) may be applied in arable fields as organic amendment to maintain soil organic matter as well as supply nutrients to crops (Gabrielle *et al.*, 2005). Organic wastes make up a large part – up to 40% – of the municipal solid waste stream. Therefore, organic wastes should be recycled from an ecological as well as from an economical point of view. In the late 1980s, composting of separately collected organic household wastes was introduced in Vienna and subsequently a municipal composting plant was set up. Due to extensive quality control measures, all compost lots produced

were suitable for agriculture and 22% even for organic farming. With wheat, a wide range of yield responses to compost fertilization has been recorded. Non-significant wheat yield increases followed the application of 6.9 t/ha biowaste compost on a parabrown soil in Germany (Erhart *et al.*, 2005).

Compost is also likely to contain a wide range of minor plant nutrients and beneficial microbes not normally present in mineral fertilizers. The typical contribution of the long-term application of quality compost has been shown to contribute to the equivalent of less than 5% of pre-existing soil heavy metal level. When considered alongside the constant contribution to soil of airborne dust, high quality compost heavy metals are now widely considered not to be significant. Together these are likely to have an additive positive effect on general soil 'health'. Composts derived from segregated wastes are generally acceptably low in heavy metals and compost complying with an appropriate standard will have data to confirm this (http://www.remade.org.uk/organics/organics_documents/compostbenefitsscottishcrops.pdf).

Availability of nutrients from organic composts is often limited despite a high initial nutrient input and considerable nutrient losses frequently occur during the composting period, primarily due to gaseous emissions. As nutrients are a limited resource in organic production, a more efficient nutrient use is desirable. It was hypothesized that such high efficiency composts could be prepared by splitting the addition of the nutrient rich material during the composting process. The remaining nutrient rich material should be added later in the process when the turnover of the wheat straw would already be proceeding. Decomposition of the newly added material would then result in less N immobilization compared to compost produced by a single addition at the beginning of the process (Dresboll *et al.*, 2004).

Decomposition of plant tissue depends on various factors including temperature, moisture content, oxygen content and residue quality. In general, both resource quality and physiochemical parameters affect the composition and activity of the decomposer communities conducting the mineralization/immobilization processes of decomposition. Thus, when producing plant based compost to be used as growing medium in horticultural productions, choice of plant material is a key factor, as root proliferation and development depend heavily on the physical structure and stability of the medium. The physical properties are mainly dependent on the starting material and are difficult to alter during production (Caron and Nkongolo, 1999).

Nitrogen was often recognized as a limiting factor for microbial growth and activity during the decomposition of plant residues, especially in materials with a high C/N ratio such as wheat straw. However, experiments on the effect of additional N supply on the decomposition of plant residues showed different results, ranging from positive to negative effects on the decomposition rate. Resource quality, microclimatic conditions and decomposer efficiency are major factors regulating composition and activity of decomposer communities and hence the process of decomposition and nutrient release. Thus, the effect of added N on decomposition depended on the plant material as degradation is influenced by nutrient content and anatomical structure of the material (Dresboll *et al.*, 2004).

Organic compost from waste may be used for various purposes, among which are soil recovery, commercial production, pastures, lawns and reforestry and agriculture.

However, the quality of compost determines the plant growth and development of plants. The effect of compost made from urban waste on corn plant (*Zea mays* L.) growth was investigated. Two types of compost were used: the selected compost (SC), produced from organic waste selectively collected; and the non-selected compost (NSC) (Lima *et al.*, 2004).

A series of field and pot trials were carried out to determine the effects of growing wheat and oilseed rape in soils supplemented with green waste composts and additional fertilizers. It was consistently shown that the response of wheat and rape to compost and fertilizer applied together was greater than the responses to the individual additives, but only when very stable compost was used (>10 months processing). Experiments with ^{15}N -labeled fertilizer revealed that wheat was able to utilize the applied nitrogen more efficiently when cultivated in the stable compost. The enhanced growth was also demonstrated in hydroponic culture of oilseed rape with water extracts of green waste compost in the presence of compound fertilizer (Keeling *et al.*, 2003). However, a technical difficulty was the lack of a reliable and inexpensive methodology to examine the fate of compost in soil and to quantify compost effects on soil organic matter (SOM). Organic amendments often supply much greater C inputs to soil than are derived from crop residues. Relatively few studies applied the isotope $\delta^{13}\text{C}$ technique to improve our understanding of the transformation, utilization and stabilization of amendment carbon in soil (Lynch *et al.*, 2006). Composting temperature is influenced by moisture content, degree of aeration, size of the pile and climatic conditions, particularly air temperature and rainfall. The finished compost is friable humus with moisture content less than 40%. Although too low in nutrients to be considered a fertilizer, compost is an excellent soil conditioner (Hammer and Hammer, 2004).

Changes in physicochemical characteristics during composting of tannery effluent, wheat straw and cow manure are given in Figure 10.3. A schematic diagram of the composting process is presented in Figure 10.4.

Pyrolysis

Pyrolysis is the first and most basic thermo-chemical step to convert biomass into gaseous or liquid fuels. However, despite the fact that pyrolysis underlies humankind's oldest technology (the use of fire), it is still not a predictive science (Green and Feng, 2006). Pyrolysis is the decomposition of a complex organic substance to one of a simpler structure by means of heat in the absence of oxygen or any other reagents, except possibly steam. Some polymers will depolymerize in the presence of excessive temperatures, either to polymers of lower molecular weight, or back to the monomers from which they were derived (<http://composite.about.com>).

Pyrolysis typically occurs under pressure and at operating temperatures above 430°C . In practice, it is not possible to achieve a completely oxygen-free atmosphere. Because some oxygen is present in any pyrolysis system, a small amount of oxidation occurs. If volatile or semi-volatile materials are present in the waste, thermal desorption will also occur (<http://www.cpeo.org/techtree/ttdescript/pyrols.htm>). Pyrolysis is thermal degradation of waste in the absence of air to produce char, pyrolysis oil and syngas,

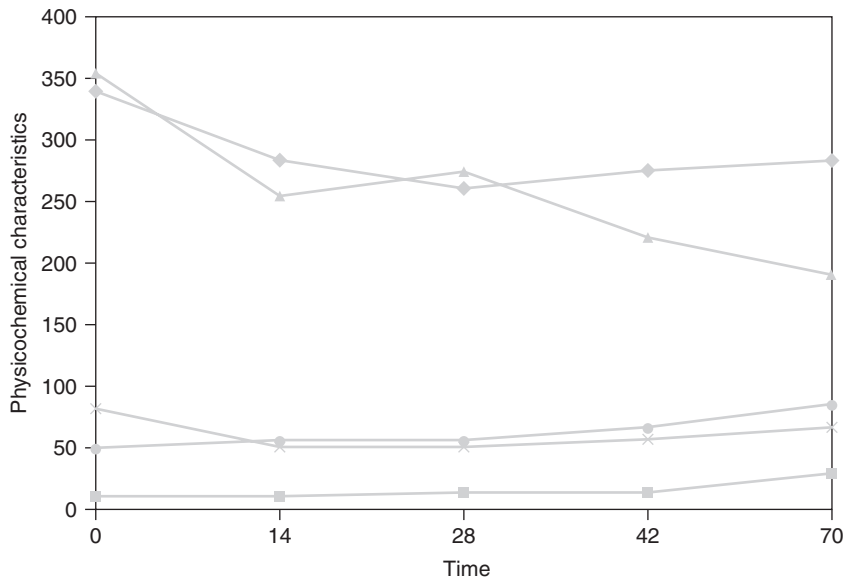

Figure 10.3 Changes in physicochemical characteristics (◆ total carbon, ■ total nitrogen, ▲ lignin, X cellulose and ● ash content) versus composting time of tannery effluent, wheat straw and cow manure (adapted from Conteras-Ramos *et al.*, 2004)

e.g. the conversion of wood to charcoal (http://www.juniper.co.uk/services/Our_services/P&GFactsheet.html). The manner, in which pyrolysis functions offers some advantages over conventional incineration. First, because no air is fed into the combustor, far less waste gases are produced and therefore the gas cleaning system can be smaller and hence less costly. Secondly, the waste itself must be pre-prepared to make it homogeneous and to remove bulky materials. Thirdly, in theory the solid, liquid and gaseous streams can be further processed into useful products and hence there should be less material to discard to landfill (Harrison, 2001). Extreme pyrolysis, that leaves only carbon as the residue, is called carbonization (<http://en.wikipedia.org/wiki/Pyrolysis>).

Organic materials are transformed into gases, small quantities of liquid and a solid residue containing carbon and ash. The off-gases may also be treated in a secondary thermal oxidation unit. Particulate removal equipment is also required. Several types of pyrolysis units are available, including the rotary kiln, rotary hearth furnace or fluidized bed furnace. Pyrolysis is not effective in either destroying or physically separating inorganics from the contaminated medium. By-products containing heavy metals may require stabilization prior to their final disposal (<http://www.cpeo.org/techtree/ttdescript/pyrols.htm>). Flash pyrolysis gives high oil yields but, because of the technical efforts required to process pyrolytic oils, this energy generating system does not seem to be very promising at the present stage of development. However, pyrolysis as a first stage in a two-stage gasification plant for straw and other agricultural feedstocks posing technical difficulties in gasification does deserve consideration. Pyrolysis of biomass generates three different energy products in different quantities: coke, oils and gases (<http://www.tab.fzk.de/en/projekt/zusammenfassung/AB49.htm>).

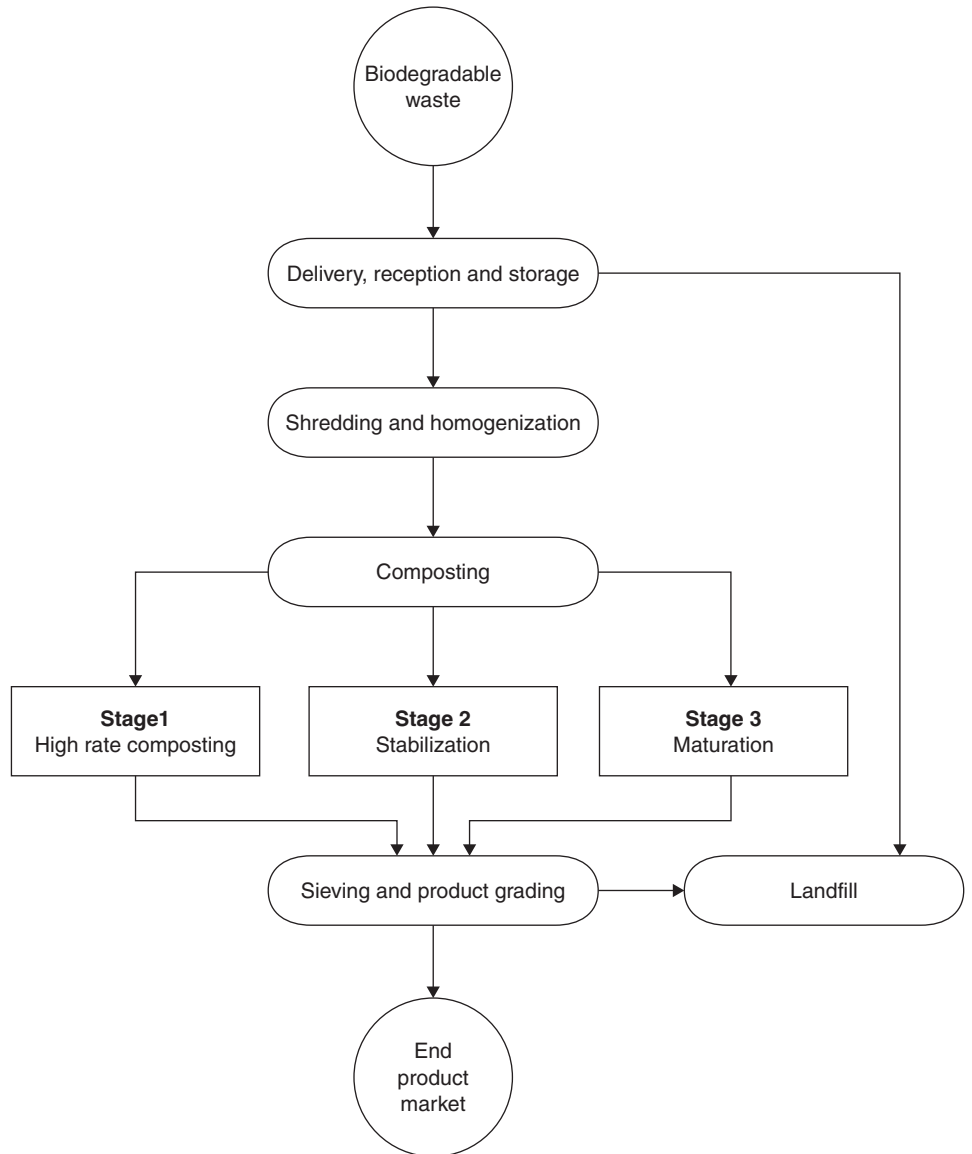

Figure 10.4 Schematic diagram of the composting process (adapted from McLanaghan, 2002; Swan *et al.*, 2002; Williams, 2005)

Anhydrous pyrolysis can be employed to produce liquid fuel similar to diesel from solid biomass. The most common technique applies very low residence times and high heating rates thereby using a temperature between 350 and 500 °C and is called either fast or flash pyrolysis. When burning compact solid fuel, like wood, the flames of a wood fire are due to combustion of gases released by pyrolysis, not combustion of the wood itself. Thus, the pyrolysis of common materials like wood, plastic and clothing is extremely important for fire safety and fire fighting (<http://en.wikipedia.org/wiki/Pyrolysis>).

Pyrolysis (PY) is an interesting degradative technique because it can be easily coupled to gas chromatography (GC), mass spectrometry (MS) or GC/MS, thus allowing the online degradation of polymers and the analysis of their fragments by hyphenated techniques such as PY/GC, PY/GC/MS or PY/MS (Rodriguez *et al.*, 1997). The pyrolysis products identified were mostly related to carbohydrates (furans), proteins (nitriles and pyrrols), chitin (pyridines and pyrazols), lipids (alkanes and derivatives of benzene) and lignin (phenols). The relative yield of all individual pyrolysis products was similar in the samples from the maize (C₄) and control wheat (C₃) soil (<http://dbs.clib-jena.mpg.de/dbs-publ/pubi/bgc/BGC0130.pdf>).

Over the past decade, flash pyrolysis (FP), or thermolysis, became a process in which materials, i.e. biomass, are rapidly heated to high temperatures in the absence of air (oxygen). In this process, the biomass is decomposed into a mixture of solid char, gas, vapors and aerosols. When the components were quenched, the volatile components condensed to bio-oil. It was found that the percentages of these components and product yields were strongly affected by the temperature of reaction and heating rate inside the reactors. Bio-oil is a liquid mixture of oxygenated compounds containing various chemical functional groups, such as carbonyl, carboxyl and phenolic. It can be effectively used as a substitute for fuel (Shuangninga *et al.*, 2005).

Some of the main objectives were to characterize and study the preparation of biomass to meet the necessary specifications to be used for bio-oil production in the rotating cone pyrolysis technology. This included selection of a number of relevant biomass materials based on primary criteria such as their high availability in the EU and low production costs. Biomass materials with certain degree of homogeneity and/or low humidity content were also considered as agro-industrial and agricultural residues produced in Southern Europe and well suited to be utilized in pyrolysis technology. An appraisal of the resource availability and costs was developed in order to assess the selection of the biomass to be studied in detail within the project resulting in selection of twenty substrates (<http://www.biomatnet.org/secure/Fair/F538.htm>).

Bio-oil from fast pyrolysis is, in many ways, different from other liquid fuels (such as rapeseed oil or bioethanol derived) from biomass like. It also differs significantly from diesel fuel in both physical properties and chemical composition. Bio-oil contains water and solids; it is acidic and has a low calorific value. Therefore, the first task was to determine the chemical and physical properties of pyrolysis oil generated using this technology from different feedstocks and compare them with other biofuels and fuels derived from mineral oil. The standard methods developed for petroleum based fuels need to get adapted to bio-oil (<http://www.dynamotive.com/biooil/technology.html>).

The fast pyrolysis process converts forest and agricultural residue (including bark) into liquid bio-oil and char. Bio-oil is a clean burning, greenhouse gas neutral fuel that will initially be used to replace fossil fuels to generate power and heat in stationary gas turbines, diesel engines and boilers and to replace natural gas in the forest industry and to replace another product in the coal industry. The char is a high heating value solid fuel that can be used in kilns, boilers and the briquette industry. Three products are produced: bio-oil (60–75% wt), char (15–25% wt) and non-condensable gases (10–20% wt) (<http://www.biomatnet.org/secure/Fair/F538.htm>).

The fast pyrolysis process is carried out as follows: prepared feedstock (<10% moisture and 1–2 mm particle size) is fed into the bubbling fluid-bed reactor, which is heated to 450–500°C in the absence of oxygen. This is lower than conventional pyrolysis systems and, therefore, has the benefit of higher overall energy conversion efficiency (<http://www.dynamotive.com/biooil/technology.html>).

Thermogravimetric analyzer (TGA) was the main instrument used in analyzing the characteristics of solid fuel volatilization at low-heating rates. The maximum heating rate of TGA could reach as high as 100 °C/min. For years, pyrolysis and combustion reactions of pulverized biomass were investigated in various applications using TGA. Kinetic studies showed a great deal of variations in the measured kinetic parameters of apparent frequency factor and apparent active energy. This could be attributed to the diversity of the biomaterials and experimental conditions. Laminar entrained flowreactor (LEFR) was used to study the chemical characteristics of pulverized coals and other solid fuels in order to provide much higher heating rates and maintain the reaction conditions precisely (Shuangninga *et al.*, 2005). Understanding pyrolysis kinetics is important for the effective design and operation of the thermochemical conversion units, given that solid devolatilization is always a fundamental step. The TGA technique was applied in several cases for such a purpose. Thermogravimetric curves for wheat, barley, oats and rye straw have been measured in both inert and oxidizing atmospheres. Even though TGA studies provided basic information on the kinetics of straw pyrolysis, the results were not readily applicable to practical conversion systems because heating rates were generally much faster. On the other hand, analysis was not carried out on the kinetics of straw degradation under rapid heating (Lanzetta and Di Blasi, 1998).

A special automated feeding system consisting of four supply towers ensures that four boards are introduced simultaneously into the reactor chamber. Ablation rates between 2.0 and 5.5 mm/s have been achieved so far. The pyrolyzer consists basically of a rotating, vertically orientated, electrically heated disk. Solid wood boards with a cross-sectional area of 10 × 47 mm and a length of approximately 350 mm are pressed against the disk by a piston. The pressure ranges between 30 and 50 bar and the heated disk temperature is approximately 700 °C. Gas cleaning and condensation is accomplished with standard techniques such as cyclone, spray tower and electrostatic precipitator (<http://www.pyne2005.inter-base.net/docs/PyNews%2017.pdf>).

The core of the pyrolysis pilot plant is the rotating cone reactor which is a compact high intensity reactor in which biomass of ambient temperature is mixed with hot sand. Upon mixing with the hot sand at 550°C, the biomass decomposes providing 70 weight percent condensable vapors, 15 weight percent non-condensable gases and 15 weight percent char. During the project, BTG and KARA had successfully designed and constructed a fully automated pyrolysis plant with a capacity of 260 kg/h. This was operated over a number of trial periods, during which the following conditions were established as those that gave the highest oil yield and produced the best quality bio-oil:

- 1 reactor temperature of 470°C
- 2 vapor residence time <1 s
- 3 biomass particles <4 mm (<http://www.biomatnet.org/secure/Fair/F538.htm>).

Curie-point pyrolysis-gas chromatography coupled on-line to mass spectrometry (Py-GC/MS) and isotope ratio mass spectrometry (Py-GC/IRMS) were used to determine the individual turnover rate of specific carbohydrates, lignin, lipids and N-containing compounds from French arable soils. Based on the differences in isotopic enrichment of chemical structures after vegetation change, the pyrolysis products could be divided into three groups:

- 1 pyrolysis products with a nearly complete C₄ signal, e.g. phenol, derived from lignin degradation products
- 2 pyrolysis products with an intermediate isotopic enrichment of 6–8 per thousand, most likely to be a composite of remaining fragments derived from both maize and native wheat
- 3 pyrolysis products showing only low enrichments in ¹³C of 1–3 per thousand.

Most of their precursors were found to be proteinaceous materials. This implied that proteins or peptides were indeed preserved during decomposition and humification processes occurring in the soil. The analyzed soils were cultivated, either continuously with a C₃ plant or transferred to a C₄ plant cropping 23 years ago. Most pyrolysis products identified were related to carbohydrates (furans), lipids (hydrocarbons and derivatives of benzene), proteins (nitriles and pyrrole) and lignins (phenols). The relative yield of all individual pyrolysis products was similar in the samples from the maize and control wheat soil (Gleixner *et al.*, 1999).

An insight into the chemical structure of complex biomacromolecules can be obtained via pyrolytic studies and this technique has been applied to a large range of natural compounds. Among the various methods used for isolating lignin-containing materials from biomass is one yielding the so-called ‘ligno-cellulosic substrate’ (LCS). This material was obtained from wheat straw by successive acid and base treatments. Wheat straw LCS exhibits a number of interesting features in relation to metal complexation and might be suitable for important applications like metal removal from industrial effluents. This LCS was analyzed with CP/MAS ¹³C NMR spectroscopy and Py/GC/MS, in the presence and absence of tetramethylammonium hydroxide (TMAH), to derive information on its molecular composition in relation with complexation features (Gauthier *et al.*, 2003). Combined gas chromatography-mass spectrometry of the products from linked synthetic model lignin dimer treated with ¹³C-labelled TMAH suggested that the ether linkage was cleaved via intramolecular epoxide formation. Pyrolysis in the presence of TMAH was used to analyze phenolic acids, natural resins, resinates, humic acids, asphaltenes, kerogens, lignins and organic matter in near shore marine sediments. Pyrolysis of lignin in the presence of TMAH avoids decarboxylation of polar moieties and yields phenolic derivatives which are not observed during conventional analytical pyrolysis (Vane *et al.*, 2001). Combined pyrolysis/gas chromatography/mass spectrometry (Py/GC/MS) of complex macromolecular materials can provide detailed structural information but suffers limitations for the identification of compounds comprising polar functional groups like carboxylic (COOH) and hydroxyl (OH) groups. This technique was improved by introducing thermochemolysis with TMAH. Thermochemolysis corresponds to a

thermally-assisted chemolytic degradation rather than degradation simply induced by thermal bond cleavage. In addition, *in situ* methylation occurs so that a number of polar products become volatile enough for gas chromatographic analysis (Gauthier *et al.*, 2003).

Analytical pyrolysis is one of the many tools utilized for the study of natural organic polymers. Analytical pyrolysis methodology covers two distinct subjects, the instrumentation used for pyrolysis and the analytical methods that are applied for the analysis of the pyrolysis products. A variety of pyrolytic techniques and of analytical instruments commonly coupled with pyrolysis devices are given at http://www.elsevier.com/wps/find/bookdescription.cws_home/600279/description#description. The term pyrolysis is sometimes used to encompass also thermolysis in the presence of water, such as steam cracking of oil, or more generally hydrous pyrolysis. The applications of analytical pyrolysis included topics such as polymer detection, used for example in forensic science, structure elucidation of specific polymers and identification of small molecules present in polymers (antioxidants, plasticizers, etc.).

Analytical methods based on pyrolysis gas chromatography coupled to mass spectrometry (Py-GC-MS) present great potential due to the small amount of sample required for analysis and the type of information provided. Milled wheat straw was treated with an Mn^{2+} oxidizing peroxidase from *P. eryngii* and the changes produced evaluated by analytical pyrolysis. The results obtained included quantitation of lignocellulose pyrolysis products after peroxidase treatment and information on the action of the enzyme on phenolic and non-phenolic lignin units. The phenolic moiety increased lignin solubility and extractability from lignocellulose and modified the characteristics of lignins as an industrial raw material (Camarero *et al.*, 2001). Analytical pyrolysis was shown to be very effective in the characterization of lignins, where most of the pyrolytic fragments are not secondary rearrangement products, but diagnostic compounds in which the structure of the main building blocks of the macromolecule is preserved. In this way, a semiquantitative assessment of the monomer composition for the different lignin types can be made: in fact, pyrolysis combined with gas chromatography and mass spectrometry proved to be a valuable tool for the analysis of pulp samples (Galletti *et al.*, 1997).

Pyrolysis and gasification are thermal processes that employ high temperatures to break down any waste containing carbon. Pyrolysis was carried out at 600°C for 5 s. Py-GC interface was set at 200°C. The GC column was a SPB-5 and was operated from 50 to 290°C at 5°C/min, holding the initial temperature for 10 min. The injector was set at 250°C in the split mode. Mass spectra were recorded under electron ionization at 70 eV, spectral range from 40 to 450 m/z, 1 scan per second. To optimize Py-GC:MS quantitation of lignin and polysaccharide pyrolysis products, correction factors for the use of 1,3,5-tri-tert-butylbenzene as internal standard were obtained for different phenolic standards (Martinez *et al.*, 2001).

Pyrolysis yields of carbon products prepared from agricultural waste corn cob with chemical physical activation are presented in Figure 10.5 and element analysis of rice husk heat treated under pyrolytic conditions at different temperature is given in Figure 10.6 and Figure 10.7. A system boundary in the various cropping and alternative

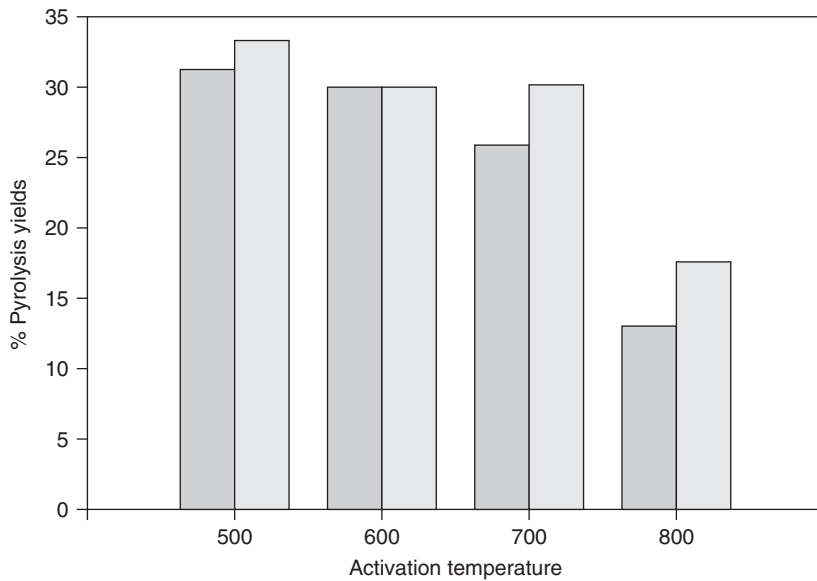

Figure 10.5 Pyrolysis yields of carbon products prepared from agricultural waste corn cob (■ KOH activating agent, ■ K₂CO₃ activating agent) by chemical physical activation (adapted from Tsai *et al.*, 2001)

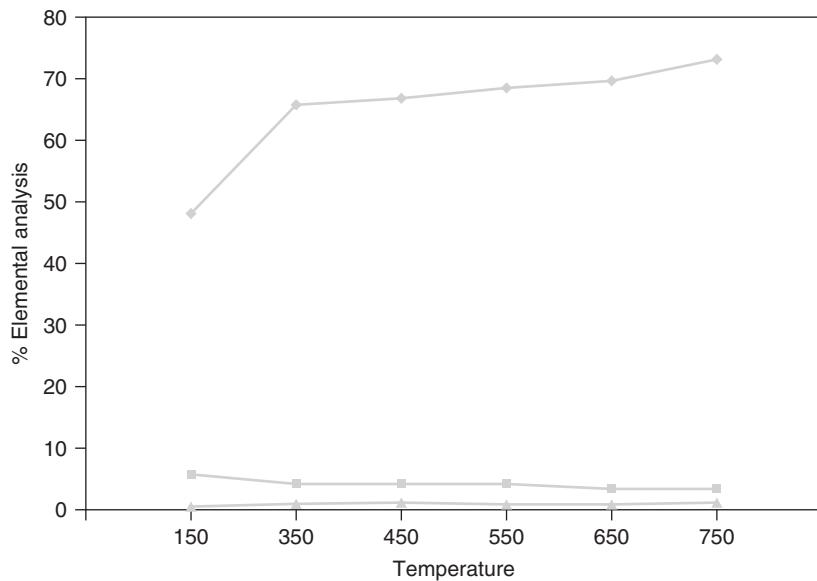

Figure 10.6 Elemental analysis of rice husk heat treated (◆ C, ■ H and ▲ N) under pyrolytic conditions at different temperatures (adapted from Maiti *et al.*, 2005)

production systems is presented in Figure 10.8. Material and energy balances of the rice husk gasification process and flow sheet of rice husk fluidized bed fast pyrolysis and fluidized bed fast pyrolysis catalytic treatment processes are given in Figure 10.9 and Figure 10.10, respectively.

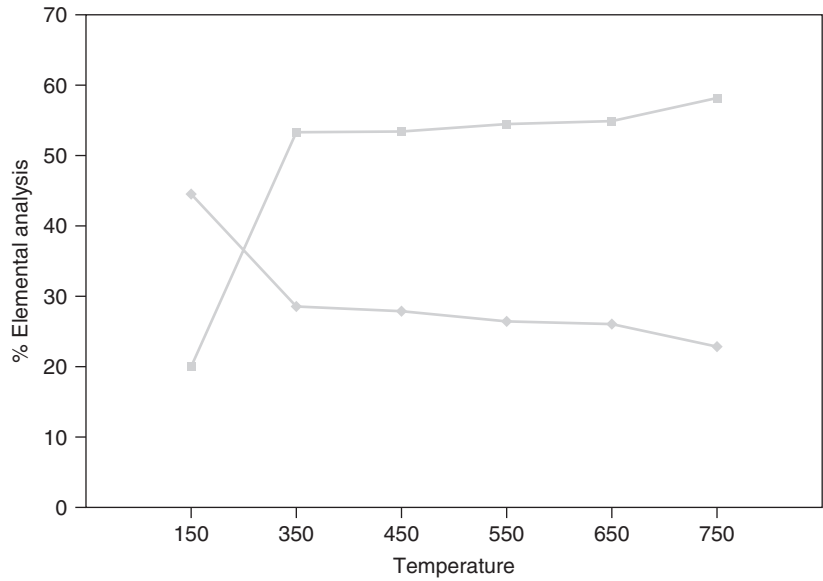

Figure 10.7 Elemental analysis of rice husk heat treated (◆ O-free dry ash and ■ dry ash) under pyrolytic conditions at different temperatures (adapted from Maiti *et al.*, 2005)

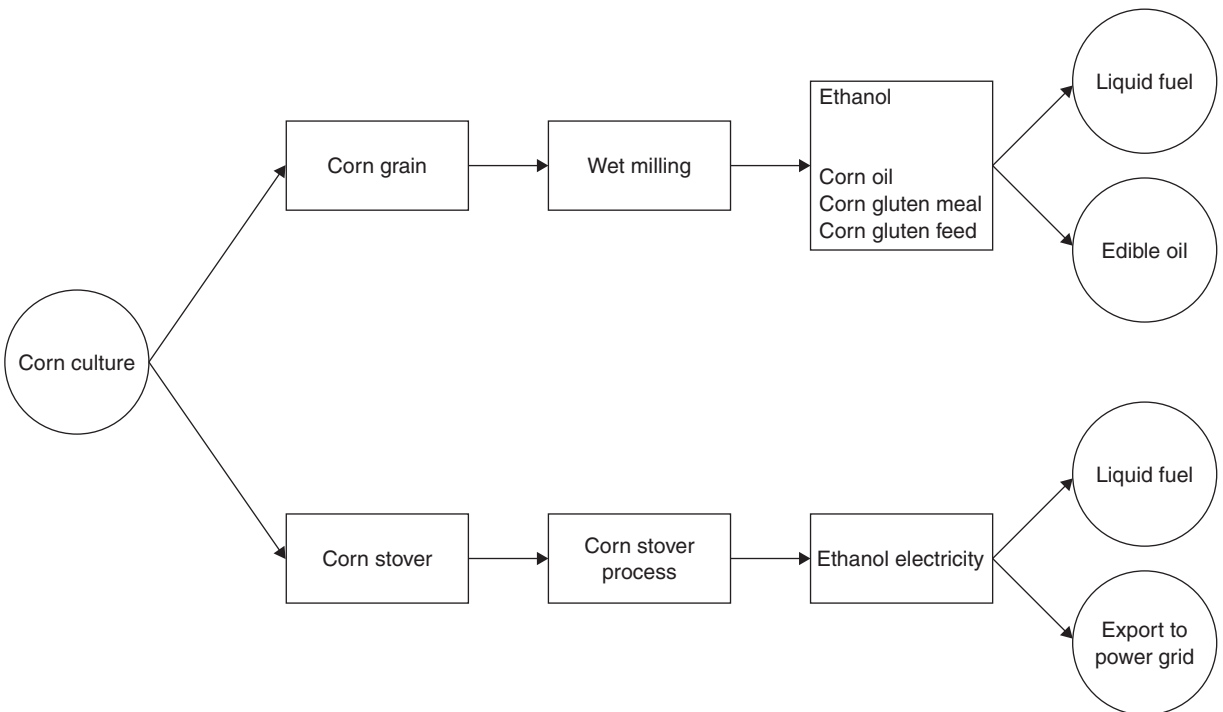

Figure 10.8 System boundaries in the various cropping and alternative production systems (adapted from Seungdo *et al.*, 2005)

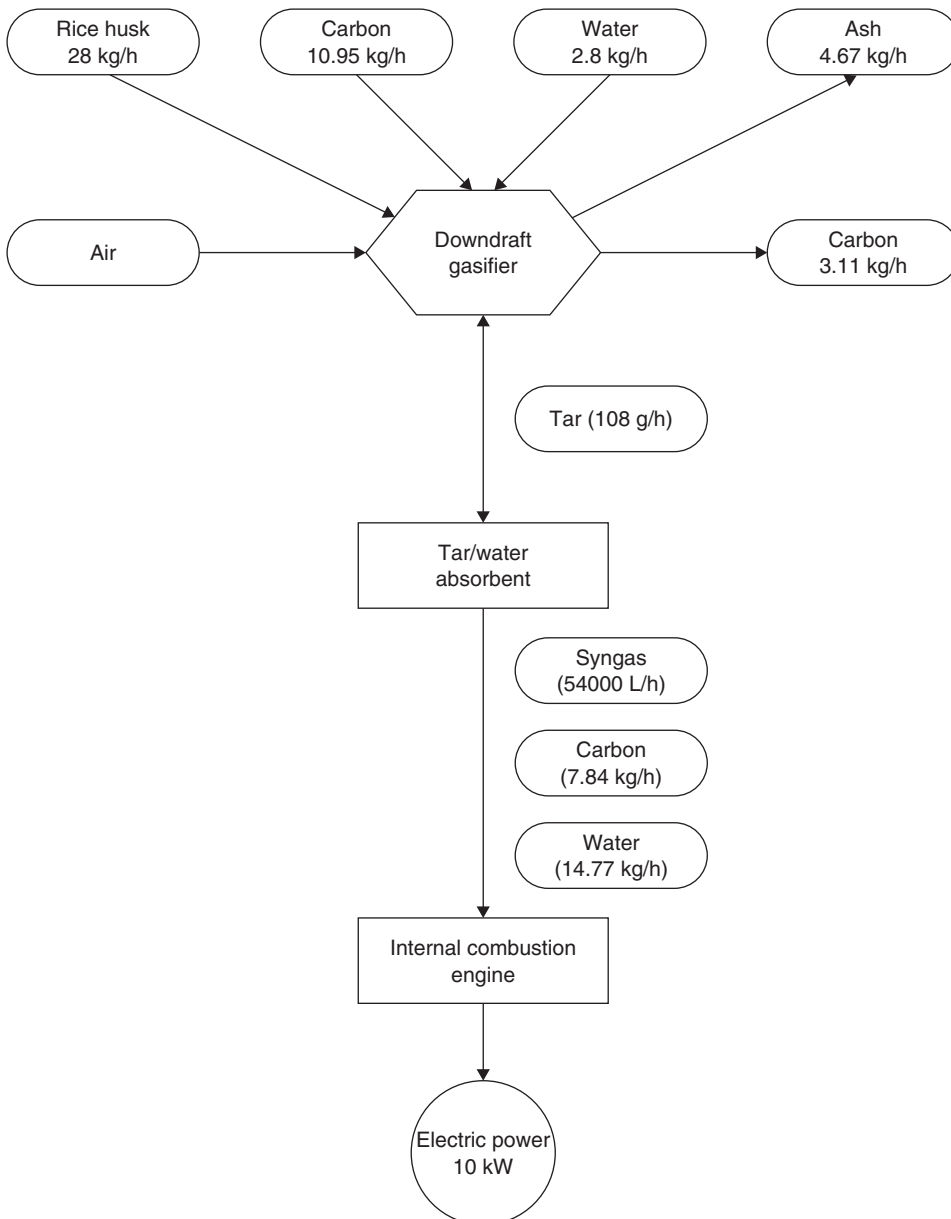

Figure 10.9 Material and energy balances of the rice husk gasification process (adapted from Lin *et al.*, 1998)

Gasification

The gasification process breaks down the hydrocarbons left into a syngas using a controlled amount of oxygen. Gasification and pyrolysis typically rely on carbon-based waste such as paper, petroleum-based wastes like plastics and organic materials such as food scraps. Gasification involves a small amount of oxygen, whereas pyrolysis uses

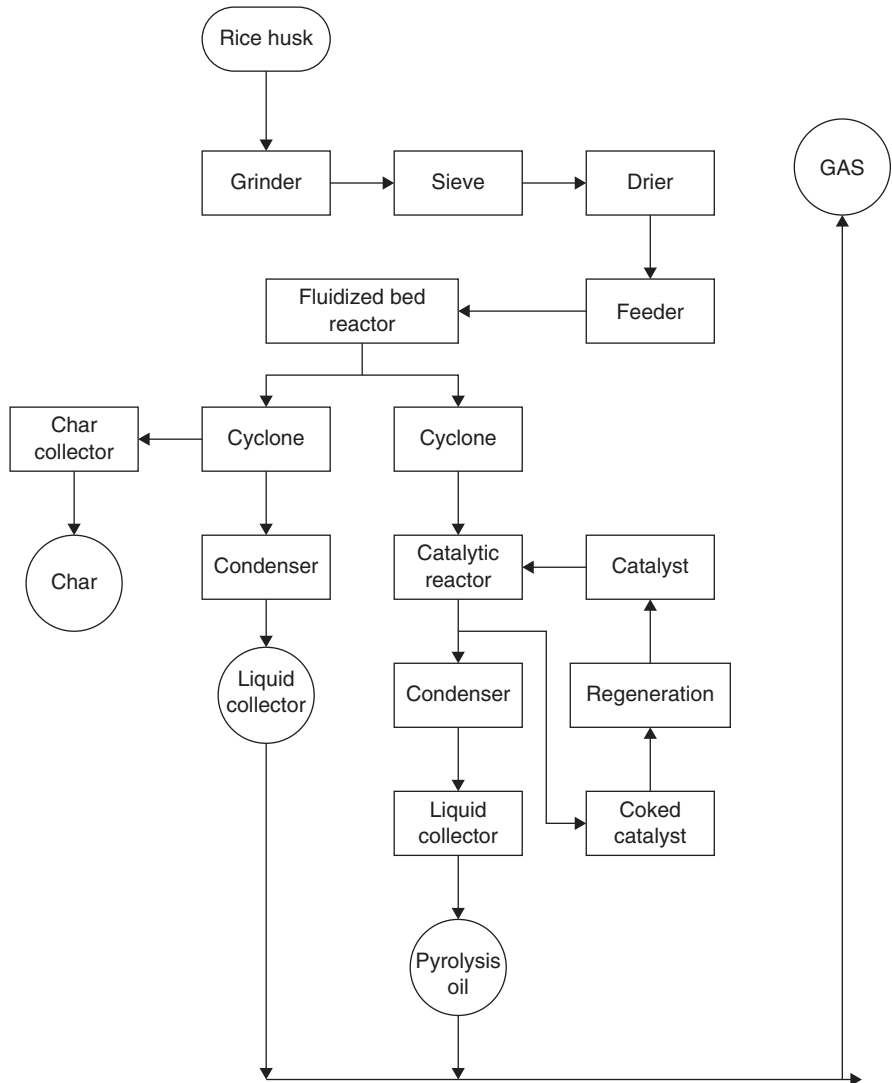

Figure 10.10 Flow sheet of rice husk fluidized bed fast pyrolysis and fluidized bed fast pyrolysis catalytic treatment processes (adapted from Islam *et al.*, 2004)

none (http://www.foe.co.uk/resource/triefings/gasifications_pyrolysis.pdf). Gasification can be used in conjunction with gas engines (and potentially gas turbines) to obtain higher conversion efficiency than conventional fossil-fuel energy generation. By displacing fossil-fuels, waste pyrolysis and gasification can help meet renewable energy targets, address concerns about global warming and contribute to achieving Kyoto Protocol commitments. Conventional incineration, used in conjunction with steam-cycle boilers and turbine generators, achieves lower efficiency (http://www.juniper.co.uk/services/Our_services/P&GFactsheet.html).

Gasification involves subjecting solid biomass to hot steam and air to produce a gaseous biofuel. This gas, often known as 'synthesis gas' may be burnt directly for

heating and/or electricity production or may be further converted to act as a substitute for almost any fossil fuel. The advantage of gas, over biomass, is that it is a 'better' fuel, having a higher calorific value and being more easily stored and transported. The gas can often be used to produce electricity directly in CCGT (combined-cycle gas turbine) power stations. This, not new technology, is far more likely to be applied nowadays, to renewable resources, such as wood, from short-rotation coppice or forestry residues (<http://www.ecocentre.org.uk/biomass.html>).

Gasification relies on chemical processes at elevated temperatures $>700^{\circ}\text{C}$, contrary to biological processes such as anaerobic fermentation (digestion) which releases biogas. Gasification is a process that converts carbonaceous materials, such as coal, petroleum, petroleum coke or biomass, into carbon monoxide and hydrogen. The gasification process occurs as the char reacts with carbon dioxide and steam to produce carbon monoxide and hydrogen (<http://en.wikipedia.org/wiki/Gasification>).

The gasification of herbaceous biomass is still at an early stage of research and development. Intensified development efforts on gasification technologies for herbaceous biomass feedstocks are desirable as the potential supply of this group of fuels is comparatively large. Gasification of wood and wood-type residues and waste in fixed bed or fluidized bed gasifiers with subsequent burning of gas for heat production is the current state of the art. The wood gasifiers employed primarily in the Scandinavian countries are used almost entirely for heat generation (<http://www.tab.fzk.de/en/projekt/zusammenfassung/AB49.htm>).

The gasification technologies developed by competing suppliers of gasification power plants are based either on fixed bed gasification or fluidized bed gasification. Two types of fixed bed gasifiers can be principally distinguished by the direction the gasification air and produced fuel gas move through the reactor: updraft and downdraft gasifiers. Updraft gasifiers were more easily scaled up compared to a downdraft gasifier but do produce more undesirable tars (<http://www.ecn.nl/docs/library/report/2000/c00080.pdf>).

The energy efficiency reached 60% without including energy recovery, whereas with energy recovery, the overall energy yield reached 90%. Economical evaluation of this process can also be found in the literature. It was calculated that the cost of the product gas of the supercritical water gasification process is 1.86 times more expensive than city gas in Tokyo (D'Jesus *et al.*, 2006). A wide range of biomass fuels such as wood, charcoal, wood waste (branches, roots, bark, saw dust) as well as agricultural residues – maize cobs, coconut shells, cereal straws, rice husks – were used as fuel for biomass gasification. Theoretically, almost all kinds of biomass with moisture content of 5–30% can be gasified, however, not every biomass fuel leads to successful gasification. The fuel size substantially affects the pressure drop across the gasifier and power that must be supplied to draw the air and gas through the gasifier. Large pressure drops will lead to reduction of the gas load in a downdraft gasifier, thus resulting in low temperature and tar production (<http://mitglied.lycos.de/cturare/fue.htm>).

Compared to other biomass energy conversion technologies, supercritical water gasification (SWG) is the most efficient one for biomass with a high moisture content (40%). In spite of the high pressure and high temperature required for biomass conversion with supercritical water, the process is technically feasible because tubular or slim vessel type reactors can be used (D'Jesus *et al.*, 2006). Excessively large sizes of

particles give rise to reduced reactivity of fuel, causing a start-up problem and poor gas quality (<http://mitglied.lycos.de/cturare/fue.htm#size>).

The influence of process variables like temperature, pressure, residence time and catalyst on supercritical water gasification of model compounds was investigated. The best hydrogen yield for the supercritical water gasification of sawdust and different starches was reached at high temperatures. A similar observation regarding the effect of temperature was reported in other publications (D'Jesus *et al.*, 2006). The pressure had no great effect on the glucose gasification efficiency and the fraction of the gas product. A decrease of pressure led to an increase in hydrogen formation. Carbon conversion did not vary at a longer residence time. The efficiency was observed to be decreased by a shorter residence time (D'Jesus *et al.*, 2006). The moisture content of most biomass fuel depended on the type of fuel, its origin and treatment before it is used for gasification. A moisture content below 15% by weight is desirable for trouble free and economical operation of the gasifier. Higher moisture contents reduced the thermal efficiency of the gasifier and result in low gas heating values (<http://mitglied.lycos.de/cturare/fue.htm#moisture>).

The electric efficiency of a gasification plant is directly related to the cold gas efficiency of the gasifier. This parameter is mainly determined by the carbon conversion, the heat loss of the reactor and the fuel gas temperature leaving the reactor. Fixed bed reactors generally show a lower carbon conversion but also have a lower exit temperature of the gas. The heat loss should be lower since the specific surface (m^2/m^3) is lower (<http://www.ecn.nl/docs/library/report/2000/c00080.pdf>).

Energy content of fuel is determined in most cases in an adiabatic, constant volume bomb calorimeter. Using this method higher heating values were obtained because the condensation heat from water formed in the combustion of fuel was included. Heating values are also reported on moisture and ash basis. Fuel of higher energy content is always better for gasification. Most biomass fuels (wood, straw) have heating values in the range of 10–16 MJ/kg, whereas liquid fuel (diesel, gasoline) display higher heating values (<http://mitglied.lycos.de/cturare/fue.htm#energy>).

Combustion

The combustion of biomass is considered a two-step process: devolatilization to char and volatiles, and combustion of volatiles and char. A number of parameters are required as inputs to existing CFD particle combustion models, such as devolatilization yields and rates, composition of volatiles, amount of char formed and char burning rates (Jones *et al.*, 2000). Although combustion involves complicated chemical reactions and fluid dynamical processes, including the development of instabilities, a high degree of experimental control can be obtained over the combustion and it could be studied in detail by using a two-dimensional chamber that prevented convection. Measurements were taken when the combustion was very slow, i.e. the fuel was smoldering, a non-flaming mode in which the emitted gas did not glow. In this mode, the oxygen interacted with a solid fuel to produce char, gaseous products and the required heat for completion of the process (<http://www.esam.northwestern.edu/~matkowsky/fingering.html>).

The combustion gases typically pass through a boiler system to recover energy. The most flexible means of recovering energy from the hot gases is to produce steam for

direct use or for electricity generation. To generate electricity, superheated steam is passed from the boiler system to a turbine generator (Harrison, 2001). During combustion, all fuel is converted to a hot gas (flue gas), which can be used to generate steam in a boiler and subsequently generate electricity in a steam turbine/generator. The electric efficiency is mainly the result of the efficiency of the steam turbine. Fuel gasification resulted in production of a combustible fuel gas. The gas was combusted in a gas turbine or gas engine. Electric efficiency is the product of the efficiency of the gasifier (approx. 80%) and the turbine or gas engine (30–40%). A steam turbine was coupled to convert 'waste' heat to electricity. For gasifiers, the efficiency was relatively high for small-scale systems. Only below 0.1 Mwe did the efficiency drop due to a lower efficiency of both the gasifier and engine (<http://www.ecn.nl/docs/library/report/2000/c00080.pdf>).

The use of an elevated pressure of oxygen inside a closed metal container in the form of oxygen bomb combustion is an alternative procedure for complete oxidation of biological samples. The sample was burnt using the normal practices involved in determining the calorific value of coal and sulfur was determined with potentiometric titration. An oxygen combustion bomb-ion chromatography (IC) method was reported for elemental analysis of organic compounds, fuel and hazardous wastes with indirect photometric detection. Combustion with oxygen in a sealed bomb was used to convert solid and liquid combustible samples into soluble forms for chemical analysis (Souza *et al.*, 2002). Nitrogen freed by combustion at high temperature in pure oxygen was measured with thermal conductivity detection and converted to equivalent protein by appropriate numerical factor. Any instrument or device designed to determine nitrogen by combustion may be used provided it is equipped as follows:

- 1 furnace to maintain minimum operating temperature of 950°C for pyrolysis of sample in pure (99.9%) oxygen
- 2 system to isolate liberated nitrogen gas from other combustion products for subsequent determination with thermal conductivity detector
- 3 detection system to interpret detector response as % nitrogen (weight/weight).

Other features tentatively included are calibration on standard material, blank determination and barometric pressure compensation (http://www.foragetesting.org/lab_procedure/sectionB/3/part3.3htm). The off-gases containing volatile organic compounds (VOCs) from covered treatment facilities will have to be treated before they can be discharged to the atmosphere. Options for the off-gas treatment include:

- 1 vapor-phase adsorption on granular activated carbon or other VOC selective resins
- 2 thermal incineration
- 3 catalytic incineration
- 4 combustion in a flare
- 5 biofiltration
- 6 combustion in a boiler or process heater (Tchobanoglous *et al.*, 2003).

Worldwide, many regions have experience with alternative fuels other than conventional diesel and gasoline. In Europe, liquefied petroleum gas (LPG), fatty acid methyl

ester (FAME), methanol (M85), biodiesel and bio-compressed natural gas (bio-CNG) have been tested and used in niche markets. Brazil has extensive experience with alcohol (ethanol-program) and palm oil as well as compressed natural gas (CNG). The world has for sometime witnessed growing concern over the environmental impact and/or exhaustion of conventional fossil fuel energy sources. The concern highlighted the need for diversification and prompted research worldwide into potential alternative sources of fuel energy for the internal combustion engine. Environmental well-being requires a modified mix of energy sources to emit less carbon dioxide, starting with a move towards alternative fuels (Zhang and Wang, 2006).

Combustion stabilized in a porous plug burner, in which the flame front is flat, was studied. Ordered states of cellular flames consisting of concentric rings of cells were observed. One or more of the rings of cells drifted in a circular path, speeding up and slowing down. In a solid porous medium, the flow of gas containing oxidizer can react with the reactive component of the porous matrix through which it moves. Such propagation of combustion waves is called filtration combustion. The latter is of great importance because it occurs not only in natural processes such as smoldering and underground fires, but also in coal gasification, the self-propagating high-temperature synthesis of materials, regeneration of coked catalysts, calcination and agglomeration of ores, oil extraction and waste incineration (<http://www.esam.northwestern.edu/~matkowsky/fingering.html>).

Incineration sources of impacts and effects on the environment are shown in Figure 10.11.

Biogas

Biogas technology is a complete system in itself with its set objectives (cost-effective production of energy and soil nutrients), factors such as microbes, plant design, construction materials, climate, chemical and microbial characteristics of inputs and the interrelationships among these factors. Biogas is about 20% lighter than air and has an ignition temperature in the range of 650–750°C. It is an odorless and colorless gas that burns with clear blue flame similar to that of LPG gas. Its calorific value is 20 MJ/m³ and burns with 60% efficiency in a conventional biogas stove (<http://www.fao.org/sd/EGdirect/EGre0022.htm>). High energy yields were obtained from the production of upgraded biogas used for vehicle refueling purposes. Comparisons indicate that energy yields from biogas derived from wheat are twice as high as when wheat is used for ethanol production. As well as economic and air quality benefits, studies also indicated that using biogas for transport, CO₂ emissions could be reduced on a life cycle basis by between 65 and 85% on current fuels, depending on the feedstock used (<http://www.ngvglobal.com/index.php?option=com-content&task=view&id=83&Itemid=2&lang=en>).

Compressed natural gas (CNG) comes primarily from fossil sources, although 'biogas', which is very similar to CNG, is produced from renewable sources. Air quality benefits are particularly significant compared with heavy-duty diesel vehicles and it is in these vehicles that CNG tends to be used. CNG engines are also significantly less noisy than diesel engines. Again, this is a particular benefit when CNG is used in heavy-duty vehicles (<http://www.defra.gov.uk/ENVIRONMENT/consult/greenfuel/response/03.htm>).

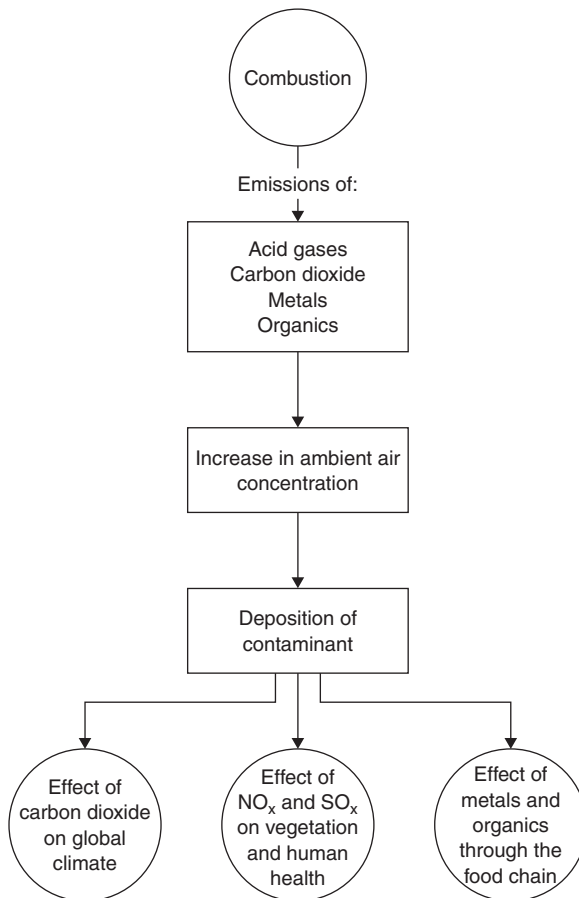

Figure 10.11 Incineration sources of impacts and effects on the environment (adapted from Petts and Eduljee, 1994; Williams, 2005)

Biogas from wheat has the highest energy balance and net energy output per hectare, particularly when straw is collected and converted into transportation fuel. Biogas from ley crops and ethanol from wheat have similar energy balances and net energy output per hectare (about 40 GJ) when the wheat pulp from the ethanol production is utilized for energy purposes (biogas production). When the wheat pulp is utilized as fodder and not for biogas production, the energy balance and net energy output per hectare for the wheat-ethanol alternative are reduced. When both wheat pulp and straw are employed for biogas production, the net energy output per hectare will be higher for the wheat-ethanol alternative than for the ley crop-biogas alternative (<http://www.miljolth.se/svenska/publikationer/visaInfo.asp?ID=>).

Uses of wheat, corn, rice, barley and oat wastes

Agriculture and forest products industries provide food, feed, fiber and a wide range of necessary products like shelter, packaging, clothing and communications. However,

biomass is also a source of a large variety of chemicals and materials and of electricity and fuels (Chum and Overend, 2001). Biomass is considered to be a potential for the renewable energy sources in the future. It already supplies 14% of the world's total energy consumption. Biomass is also a source of a large variety of chemicals and materials. Biomass resources that can be used for energy production cover a wide range of materials such as forestry residues, energy crops, organic wastes, agricultural residues, etc. Agricultural waste, a readily available biomass, is produced annually worldwide and is vastly under utilized (Putun *et al.*, 2004). About 60% of the needed process energy in pulp, paper and forest products is provided by biomass combustion. These processes could be improved to the point of energy self-sufficiency of these industries (Chum and Overend, 2001). The advantages of biomass over conventional fossil fuels are:

- 1 their low sulfur and nitrogen contents
- 2 no net emissions of CO₂ to the atmosphere when biomass production balances consumption.

Using biomass as a renewable energy source is a convenient way to produce energy without contributing to the greenhouse effect. Rice straw is one of the main cereal straws and is created as by-product of the rice milling processes in large quantities worldwide every year (Putun *et al.*, 2004).

Biomass fuels were the first energy source harnessed by mankind. They remain the primary source of energy for more than half the world's population and account for 14% of the total energy consumption in the world. Biomass is the most common form of renewable energy. The use of renewable energy sources is becoming increasingly important when it is considered to alleviate global warming and provide a fuel supply. In the past 10 years, there has been renewed interest, worldwide, in biomass as an attractive alternative to fossil fuels (Cuiping *et al.*, 2004). The reason is that build-up of residual deposits on firesides and heat transfer surfaces in furnaces and boilers are so severe that plants experience rapid decline in efficiency and increasing metal corrosion leading to increasing maintenance costs and reductions in energy revenues (Thy *et al.*, 2006). Modeling and analysis of energy conversion processes require adequate fuel characteristics, especially average and variations in elemental compositions. Knowledge of the concentration and speciation of alkali elements in fuels is useful for studies of BIGCC or other biomass power generation topics (Cuiping *et al.*, 2004). Development of biomass and other renewable power generation has distinct economic and environmental advantages (Thy *et al.*, 2006). Using biomass as a source of fuel has little adverse environmental impact. The combustion of biomass produces significantly less nitrogen oxide and sulfur dioxide than the burning of fossil fuels. Unlike fossil fuel combustions, the use of biomass fuels will not contribute to carbon dioxide levels that cause global warming. However, up to now it has not been extensively used as biomass fuel apart from domestic application (Cuiping *et al.*, 2004).

Fuel ethanol plants are being commissioned and constructed at an unprecedented rate based on this demand, though a need for a more efficient and cost-effective plant still exists. The feasibility of producing these co-products or using new processing steps is currently evaluated by performing calculations that scale-up benchtop or pilot

plant operations (Kwiatkowski *et al.*, 2006). In recent years, research and development efforts directed toward commercial production of fuel ethanol from renewable resources as an alternative transportation fuel have increased. Currently, fuel ethanol is produced almost exclusively from corn starch. The economics of fuel ethanol production is significantly influenced by the cost of raw materials, which accounts for more than half of the cost. Current processes for fuel ethanol production from corn starch have low volumetric productivities and require long fermentation times. However, the development of high-productivity and high-yield processes and reactors can potentially reduce costs (Krishnan *et al.*, 2000). Even the reduction in cost of a few cents per liter of ethanol produced is significant when dealing with the dry-grind process and the ability accurately to predict the costs of production prior to incorporating new technologies is highly desirable (Kwiatkowski *et al.*, 2006).

Today's corn refinery industry produces a wide range of products including starch-based ethanol fuels for transportation. The biomass industry can produce additional ethanol by fermenting some by-product sugar streams. Lignocellulosic biomass is a potential source for ethanol that is not directly linked to food production. Moreover, through gasification biomass can lead to methanol, mixed alcohols and Fischer–Tropsch liquids. Green plants developed to produce desired products and energy could be possible in the future. Biological systems can already be tailored to produce fuels such as hydrogen (Chum and Overend, 2001).

Ethanol is a renewable, bio-based oxygenated fuel. In the USA, the production of fuel ethanol from corn starch reached about 2.81 billion gallons in 2003. Developing ethanol as fuel, beyond its current role as fuel oxygenate, will require developing lignocellulosic biomass as a feedstock because of its abundance and low cost. Previously, corn fiber (obtained from corn wet-milling industries) was targeted as a model substrate for use as lignocellulosic biomass because of its high carbohydrate content (70%) containing 20% residual starch, 15% cellulose and 35% hemicellulose, and low lignin content (>8%) (Saha *et al.*, 2005). The corn dry-grind process is the most widely used method in the USA for generating fuel ethanol by fermentation of grain. Increasing demand for domestically produced fuel and changes in the regulations on fuel oxygenates have led to increased production of ethanol mainly by the dry-grind process. It is currently produced from sugar or starch, raw materials that are relatively expensive. To lower the production cost of bioethanol the cost of the raw material must be reduced and the production process made more efficient (Öhdren *et al.*, 2006).

Ethanol from lignocellulosic biomass is widely recognized as an environmentally friendly and acceptable substitute for gasoline or as an additive to gasoline. This acceptance has triggered increased interest in commercializing technology for production of ethanol from potentially inexpensive cellulosic feedstocks (Schell *et al.*, 2004). The concentration and speciation of heavy-metal elements is related to environment-related topics. With regard to the utilization of biomass as an energy source, the investigation of chemical elemental characteristics of biomass fuels is beneficial for biomass fuels to drive suitable energy conversion technologies and for various energy conversion processes to utilize favorable biomass feedstock (Cuiping *et al.*, 2004). An economic analysis for ethanol production from glucose revealed that cost savings of 6 cents/gal

could be achieved by using technology. These potential cost savings were realized due to higher ethanol yields, lower operating costs and lower capital costs for the continuous FBR process with an immobilized *Z. mobilis* biocatalyst compared with those for a conventional batch process using yeast (Krishnan *et al.*, 2000). Wheat straw contains 35–45% cellulose, 20–30% hemicellulose and 8–15% lignin and can also serve as a low cost attractive feedstock for production of fuel alcohol (Saha *et al.*, 2005).

The production of bioethanol from corn stover using simultaneous saccharification and fermentation (SSF) at high dry matter content addresses both issues. Corn stover is an agricultural byproduct and thus has a low economic value. SSF at high dry matter content results in a high ethanol concentration in the fermented slurry, thereby decreasing the energy demand in the subsequent distillation step (Öhdren *et al.*, 2006). A by-product of the corn wet-milling industry consists of corn hulls and residual starch not extracted by the milling process. Conversion of the starch along with the lignocellulosic components in the corn fiber would increase ethanol yields from a corn wet mill by 13% and is promising if the value of the corn fiber as an animal feed product is not severely affected. Corn fiber was obtained from a local corn wet mill and stored in a refrigerated trailer for no longer than a month. The corn fiber moisture content was 55–60% (w/w) as received (Schell *et al.*, 2004).

Ethanol production was evaluated from wheat straw (WS) hemicellulose acid hydrolysate using an adapted and parent strain of *Pichia stipitis*. The treatment by boiling and overliming with $\text{Ca}(\text{OH})_2$ significantly improved the fermentability of the hydrolysate. Ethanol yield and productivity were increased 2 490 10 and 5 790 24 fold, respectively, compared to neutralized hydrolysate. Adaptation of the yeast to the hydrolysate resulted in further improvement in yield and productivity (Nigam, 2000). The importance of compost to crop productivity has been recognized widely as an alternative nutrient source, but the mechanism of its function has not been elucidated fully. Hence, several studies have been initiated to:

- 1 find out the efficient and rational combination of composting of rice straw with poultry manure and oilseed rape cake
- 2 evaluate the comparative effectiveness of four kinds of rice straw compost on growth and yield of faba bean plants
- 3 assess the properties of soil supplied by different concentrations of straw compost (Abdelhamid *et al.*, 2004).

Wheat is one of the major sources of food in many countries. Average yield per hectare of major crops including wheat is the lowest in the world. Variation in $^{13}\text{C}/^{12}\text{C}$ ratio in C-3 plants occurs during the fixation of CO_2 due to differential stomatal diffusivities of $^{13}\text{CO}_2$ and $^{12}\text{CO}_2$ as the ribulose biphosphate carboxylase enzyme discriminates against the inclusion of the heavier C isotope. The latter study indicated that $\delta^{13}\text{C}$ of plant material depends upon weather and soil moisture conditions experienced by the plant during growth. The variation in fractionation is due to many factors such as plant type, genotypes and environment and has been used to study a variety of issues. The C isotope fractionation by photosynthesis has made it possible to characterize a plant by its C isotope composition ($\delta^{13}\text{C}$) and/or isotope discrimination value (Iqbal *et al.*, 2005).

The traditional disposal method for rice and wheat straw in many parts of the world is burning. The burning of wheat straw is popular in China because of the short turnaround time between the wheat harvest and rice transplanting in rice–wheat rotations. Estimated losses are up to 80% of N, 25% of P and 21% of K in addition to the problem of air pollution. Furthermore, declining or stagnating yields have been observed in rice-based cropping systems. Improvements are therefore required in the management of soil, water and straw (Fan *et al.*, 2005). Wood pellets are a biofuel that is much in demand and increasingly replacing oil and firewood for residential heating and hot water production. Wheat straw and peat are examples of such new raw materials. The availability of wheat straw amounted to 44 million tonnes in Europe and 1.7 million tonnes in Sweden in 2000 (Olsson, 2006). A change from traditional flooding (anaerobic) to non-flooded mulching (aerobic) and the effects of non-flooded mulching cultivation on soil temperature are likely to exert large influences on N forms and availability and N cycling. Return of straw can also lead to temporary nutrient limitation due to microbial immobilization (Fan *et al.*, 2005). Pellet appliances designed to combust a less easily burnt fuel with a higher ash content than wood pellets can be used for peat/wood and straw pellets. There are already pellet burners for straw pellets on the market in Sweden and it has been proven possible to combust wheat straw pellets in adapted residential boilers with low emissions of carbon monoxide and nitrogen oxides and relatively low emissions of sulfur dioxide (Olsson, 2006).

Rice (*Oryza sativa* L.) is an important crop in many areas of the world and yields a large amount of rice straw residue. A major portion of this agricultural waste is disposed by burning or is mulched in rice fields (Abdelhamid *et al.*, 2004). Some potential uses for rice straw have been described. It is a marginal feed that would have to compete with other cereal grain straws such as wheat and barley. Most of the rice straw harvested went to animal feed. The use of agricultural residues, including rice straw, as a source of non-wood fibers has been reviewed. It is most suitable for the production of corrugated medium and newsprint, however, the only commercial pulp mills using straw or bagasse exist in developing countries like India and China. It can be converted through bioconversion to ethanol, which is a clean-burning transportation-fuel oxygenate. Direct combustion of rice straw in a utility boiler of a biomass power plant is also an alternative for utilizing rice straw, but leaching is required to avoid slagging and fouling (Kadam *et al.*, 2000). Preparing compost from rice straw enriched with rock phosphate using cellulose degrading microorganisms and phosphate dissolving ones may not only compensate for the higher cost of manufacturing fertilizers in industry, but also provide the growing plants in alkaline soils with available phosphorus. Use of phosphate dissolving fungi in production of compost offers a solution to the waning interest of farmers in the use of organic phosphatic fertilizers in alkaline soils. The composts obtained were evaluated as organic phosphatic fertilizers in pots cultivated with cowpea plants. The effect of composts on the microbial community structure of rhizosphere soils was also studied (Zayed and Abdel-Motaal, 2005). However, an attractive alternative usage of rice straw is composting. This process has many advantages including sanitation, mass and bulk reduction and decrease of carbon (C) to nitrogen (N) ratio (C/N). Rice straw is rich in C and poor in N. Its C/N can vary from 50 to 150, which limits the composting process. This high C/N can be decreased by

increasing the basal N content of rice straw by adding oilseed rape cake and poultry manure. Mixtures of rice straw and N materials (cow dung + soybean plants) at ratios ranging from 70% to 100% rice straw were compared. The mixture containing 70% rice straw produced the most suitable compost in terms of maturity and nutrients (Abdelhamid *et al.*, 2004).

Rice straw is commonly burnt in many of the developing countries. Burning rice straw has harmful environmental implications through global addition of carbon dioxide, a gas contributing to the greenhouse effect and likely high health costs through increase in respiratory problems in the local population. The conversion of rice straw into value-added compost may have the potential to improve productivity of the crops and reduce environmental pollution. However, rice straw is among certain organic materials which are resistant to microbial attack (Zayed and Abdel-Motaal, 2005). The pyrolysis of rice straw was studied to estimate the effect of pyrolysis conditions on product yields and bio-oil composition when the heating rate was 5 K/min. Liquid products obtained from pyrolysis, inert atmosphere pyrolysis and steam pyrolysis were then fractionated into aspalphanes and maltanes. The chemical characterization has shown that the oil obtained from rice straw may be potentially valuable as fuel and chemical feedstocks (Putun *et al.*, 2004).

The addition of rice straw to wood fuels is expected to decrease both solidus and liquidus temperatures (i.e. the classic freezing point depression), but the magnitude of the depression cannot be predicted based on the available experimental data. It is plausible that typical boiler conditions during combustion are within the melting temperature of slag from blended wood and straw fuel and, therefore, that melt will be present in the slag (Zayed and Abdel-Motaal, 2005).

Bioconversion of waste residues (by-products) from cereal processing industries requires the cooperation of enzymes able to degrade xylanolic and cellulosic material. An enzyme preparation from *Humicola insolens*, Ultraflo, contains feruloyl esterases and glycoside hydrolases capable of solubilizing brewers' spent grain and wheat bran, but total solubilization was not achieved either through steric hindrance or through the lack of certain key activities. *H. insolens* feruloyl esterases released more diferulates from chemically extracted feruloylated arabinoxylan from both cereal sources than from the complex cell wall material, but less monomeric ferulic acid. The 8-*O*-4'-form of diferulic acid was released only from spent grain-derived material, whereas the chemically insoluble residue from wheat bran was more extensively degraded than the corresponding spent grain sample. Arabinoxylans with low amounts of arabinose substitutions were preferentially solubilized. These results showed that some phenolic acids in cereals are less susceptible to enzyme and alkali cleavage than others. The results also revealed that the local environment and molecular arrangement of ferulic and diferulic acids on arabinoxylan chains differ between barley and wheat, thus influencing enzyme hydrolysis (Faulds *et al.*, 2006).

The bioconversion of waste residues (by-products) from cereal processing industries requires the cooperation of enzymes able to degrade xylanolytic and cellulosic material. The type A feruloyl esterase from *Aspergillus niger*, AnFaeA, works synergistically with (1 \rightarrow 4)- β -D-xylopyranosidases (xylanases) to release monomeric and dimeric ferulic acid (FA) from cereal cell wall-derived material. The esterase was

more effective with a family 11 xylanase from *Trichoderma viride* in releasing FA and with a family 10 xylanase from *Thermoascus aurantiacus* in releasing the 5,5' form of diferulic acid from arabinoxylan (AX) derived from brewers' spent grain. The converse was found for the release of the phenolic acids from wheat bran-derived AXs. This may be indicative of compositional differences in AXs in cereals (Faulds *et al.*, 2005).

Vidmantienė *et al.* (2006) described a method for hydrolyzing the polysaccharides from cereal-derived waste to yield a sugar feedstock suitable for fermentation into technical ethanol using a complex of amylolytic and hemicellulolytic/cellulolytic enzymes. The enzymatic treatment of raw materials was carried out by liquid concentrated amylase and glucoamylase in combination with xylanase, containing also cellulase and glucanase activities. Gas chromatography was used for qualitative and quantitative analysis of the end products. Apart from ethanol, also methanol, propanol, butanol, isoamyl and amyl alcohols, acetaldehyde, ethyl acetate and methyl acetate were found in the distillate. The optimal composition of amylase, glucoamylase and xylanase was selected, dependent on the raw material. The maximum ethanol concentration reached after fermentation of rye and wheat bran was 44 g/l and for rye and wheat grain it was 73 and 69 g/l respectively. By applying a complex preparation of amylolytic and hemicellulolytic/cellulolytic enzymes to cereal and cereal residues, it was possible to increase the ethanol yield by 20–45%, thereby decreasing the content of higher alcohols by 34% and significantly decreasing the methanol concentration, in comparison with a reference sample without xylanase preparation.

The accumulation of metals by biomass was used for the removal of nickel from aqueous medium (Zafar *et al.*, 2006). The rice bran in its acid treated (H_3PO_4) form was used as a low cost sorbent. The adsorption characteristics of nickel on protonated rice bran were evaluated as a function of pH, biosorbent size, biosorbent dosage, initial concentration of nickel and time. Within the tested pH range (pH 1–7), the protonated rice bran displayed more resistance to pH variation, retaining up to 102 mg/g of the nickel binding capacity at pH 6. Meanwhile, at lower pH values the uptake capacity decreased. The percentage removal of nickel was maximum at 0.25 g of biosorbent dose and 0.25 mm biosorbent size. At the optimal conditions, metal ion uptake was increased as the initial metal ion concentration increased up to 100 mg/l. Kinetic and isotherm experiments were carried out at the optimal pH 6.0 for nickel. The metal removal rate was rapid, with 57% of the total adsorption taking place within 15–30 min. The Freundlich and Langmuir models were used to describe the uptake of nickel on protonated rice bran. The Langmuir and Freundlich model parameters were evaluated. The equilibrium adsorption data were better fitted to the Langmuir adsorption isotherm model. The adsorption followed pseudo second-order kinetic model. The thermodynamic assessment of the metal ion-rice bran biomass system indicated the feasibility and spontaneous nature of the process and ΔG° values were evaluated as ranging from -22.82 to -24.04 kJ/mol for nickel sorption. The order of magnitude of the ΔG° values indicated an ion-exchange physicochemical sorption process.

Treatment methods, physicochemical characteristics, substrate to be applied and final product/uses of corn and rice wastes are given in Table 10.7.

Table 10.7 Treatment methods, physicochemical characteristics, substrate to be applied and final product/uses

No	Substrate to be applied	Treatment methods	Physicochemical characteristics	Final products/uses	References
1	Barley	Composting	<ol style="list-style-type: none"> The final pH of the co-compost was 8.7 and the C/N ratio was 13 The percentage of germination obtained using the co-compost varied with the seeds used. It was 186% for ryegrass seeds, 85.74% for wheat seeds and 103% for barley seeds 	Barley wastes and solid poultry manure showed high organic matter content	Guerra-Rodriguez <i>et al.</i> , 2000
2	Barley straw	Composting	<ol style="list-style-type: none"> The acid/alkaline PME/glucosidase ratios dm were 1:4:1 and 3:3:1, in the mature MS and MP composts, respectively The hydrolyzing of organic P to inorganic form in manure composts was affected by the bulking agent 	The mixture of manures was co-composted with chopped barley straw (MS composting) and with <i>Sphagnum</i> peat (MP composting)	Vuorinen, 2000
3	Barley straw	Composting	<ol style="list-style-type: none"> Conductance (1:3 fresh compost/water ratio, w/w) pH (in water and in 0.01 M CaCl₂, 1:3 fresh compost/liquid ratio, w/w) Dry matter content (% fw, 105°C) Ash content (% dw, 480°C, 16 h) were all measured in triplicate 	Cattle and swine manure composted with barley straw	Vuorinen and Saharinen, 1997
4	Barley	Biogas	Strict anaerobic conditions were maintained by using an anaerobic basal medium composed of cysteine - HCL (0.5 g/l), NaHCO ₃ (3 g/l), with the pH adjusted to 7.0-7.2	Methane production from an industrial waste composed of 100% barley	Neves <i>et al.</i> , 2006
5	Wheat straw, corn cobs, barley husks	Adsorption	Use of chemical (NaOH and NH ₄ OH) and physical treatments (steam and milling) to help break down the complex lignin complex in order to improve the performance of the substrates	Soil conditioner or fertilizer	Robinson <i>et al.</i> , 2002
6	Corn cob, barley husk and wheat	Adsorption	Experiments were carried out statically at room temperature, 20 ± 2°C	Soil fertilizer	Robinson <i>et al.</i> , 2002
7	Barley	Composting	<ol style="list-style-type: none"> The Indore composting system was used, an open-air pile being turned 7 times during the composting phase of 105 days The maximum temperatures reached were 65-68°C and the humidity level was kept at 45-65% 	Fertilizer	Ayuso <i>et al.</i> , 1996

			3 The compost was then left untouched for 3 months to allow the organic matter to stabilize		
8	Corn stalk and fresh wheat straw	Pyrolysis	1 Pyrolysis temperature 2 Residence time	Bio-oil	Shuangninga <i>et al.</i> , 2005
9	Corn straw and wheat straw	Pyrolysis	At low temperatures (400 K), only equilibrium moisture content and presumably extractives are released, even for very long residence times of the solid	Gas and volatile	Lanzetta and Di Blasi, 1998
10	Corn oil and wheat germs	Chemical method	Use of different antioxidants 1 Ascorbyl palmitate (0.02% w/w) 2 BHA 3 Tert-butyl-4-hydroxyanisole (0.02% w/w) 4 Different amounts of solvent extracts, to 25 g of stripped corn oil or plant oils	Edible products as corn oil	Krings <i>et al.</i> , 2000
11	Corn cob and wheat straw	Biodegradation	Xylanase, glucanase, cellulase, <i>Phanerochaete chrysosporium</i> NRRL 6359, <i>P. chrysosporium</i> NRRL 6361 and <i>Coriolus versicolor</i> NRRL 6102	Production of enzymes	Abd El-Nasser <i>et al.</i> , 1997
12	Wheat straw	Vermicomposting	Wheat straw was pre-decomposed by inoculating it with <i>Pleurotus sajor-caju</i> , <i>Trichoderma harzianum</i> , <i>Aspergillus niger</i> and <i>Azotobacter chroococcum</i> in different combinations	Fertilizer	Anshu <i>et al.</i> , 2002
13	Wheat straw waste	Composting	Total C and N of the materials were determined, the wheat straw having a C/N ratio of approximately 100 kg/kg and the clover-grass hay a C/N ratio of 15 kg/kg	Fertilizer	Dresboll <i>et al.</i> , 2004
14	Wheat straw	Composting	1 pH 6.9 2 Negligible CaCO ₃ content 3 An organic carbon content of 11.0 g C/kg dry soil	Soil conditioner or fertilizer	Gabrielle <i>et al.</i> , 2005
15	Wheat straw	Pyrolysis, gas chromatography, mass spectrometry of acid-precipitable polymeric lignin (APPL)	Air dried for 24 h at 50 °C	The main product of solubilization of lignocellulose by different <i>Streptomyces</i> strains	Rodriguez <i>et al.</i> , 1997

(Continued)

Table 10.7 (Continued)

No	Substrate to be applied	Treatment methods	Physicochemical characteristics	Final products/uses	References
16	Wheat straw	NMR spectroscopy, conventional and pyrolysis TMAH thermochemolysis	<ol style="list-style-type: none"> 1 pH 4.5 2 Treatment with 10% H₂SO₄ for 0.5 h at 100°C to remove starch, proteins and sugars 3 Alkaline treatment, using a concentration of acid-treated material of 20 g/l with KQH for 24 h at room temperature 4 Washing with dilute HNO₃ 	Production of lignocellulosic material	Gauthier <i>et al.</i> , 2003
17	Wheat straw	Pyrolysis, gas chromatography, mass spectrometry (Py-GC-MS)	pH optimum 5	Polysaccharide and lignin content of straw	Camarero <i>et al.</i> , 2001
18	Wheat and oat straw	Pyrolysis	Temperature range 25–1060°C for straw	Chloride rich fertilizer	Davidsson <i>et al.</i> , 2002
19	Wheat straw	Pyrolysis, gas chromatography, mass spectrometry (Py:GC:MS)	<ol style="list-style-type: none"> 1 Air-dried for 24 h at 60°C 2 12 M HCl 	Compost in soil	Hernandez <i>et al.</i> , 2001
20	Wheat straw	Pyrolysis	Treatment with 7%w NaOH at 95°C for 3 h 2.5% w H ₂ SO ₄ for 3 h at 90°C	Fertilizer for production of <i>Pleurotus</i> spp.	Martinez <i>et al.</i> , 2001
21	Wheat straw	Combustion	<ol style="list-style-type: none"> 1 1273 K, 0% O₂ 2 Temperature about 1500°C 	Fuel	Jones <i>et al.</i> , 2000
22	Wheat straw	Combustion	<ol style="list-style-type: none"> 1 Temperatures ranging from 500 to 1200°C 2 Large concentration of silica (76–83 mol%) and potassium (11–12 mol%) 3 Small concentrations (<5 mol%) of calcium, sodium, magnesium and aluminum oxides as well as small amounts of chloride, sulfate and carbonate 	Renewable fuels	Blander and Pelton, 1997
23	Wheat straw	Chemical production	Bioethanol, amino acids and organic acids	Generic feedstock and fuels	Koutinas <i>et al.</i> , 2004
24	Wheat straw	Combustion	<ol style="list-style-type: none"> 1 SO₂ (1–25 µmol/mol range) 2 NO (0.5–10 µmol/mol range) 3 Temperature was held constant at 23°C 4 350 µmol/mol CO₂ 5 21% O₂ 	CO ₂ rich gas resulting from the incineration of plant biomass can be used to support photosynthesis in closed systems	Bubenbeim <i>et al.</i> , 1997

25	Wheat straw	Composting	The compost was assumed to provide 10% of its total N for plant growth over the growing season	Additional fertilizer	Keeling <i>et al.</i> , 2003
26	Wheat straw	Enzymatic hydrolysis	1 1% NaOH for 24 h 2 0–3% H ₂ O ₂ for 24 h 3 Low temperature (25–40°C)	Enzymatic production of reducing sugars	Curreli <i>et al.</i> , 1997
27	Wheat straw	Multi enzyme production	1 Wheat straw 10.0 g/l 2 Peptone 0.5 g/l 3 KH ₂ PO ₄ 2.0 g/l 4 (NH ₄) ₂ SO ₄ 1.4 g/l 5 MgSO ₄ ·7H ₂ O 0.3 g/l 6 CaCl ₂ 0.3 g/l 7 FeSO ₄ ·7H ₂ O 0.005 g/l 8 pH 7.0	Enzymatic production of sugars	Emtiazi and Nahvi, 2000
28	Wheat straw	Irradiation and chemical treatment	Treatments of irradiation and HBr or NaOH	Ruminant feeding	Al-Masri, 2005
29	Wheat straw	Enzyme activity	1 Moisture content of 74% 2 pH range of 4.5–5.5	Excellent carbon source	Jecu, 2000
30	Oat waste	Pyrolysis	The temperature is 600°C	Fuels	Dieckow <i>et al.</i> , 2006
31	Corn	Composting	The temperature of the mixture rose to >40°C within one week of the onset of composting of CSC and thermophilic phase (>40°C) temperatures were sustained for the first 7 months of the 9 month composting period	Composting has long been used for management of manure on farms	Lynch <i>et al.</i> , 2006
32	Corn cob	Chemical activation and pyrolysis	1 Impregnation ratio of 20–200 wt% 2 Heating rate of 10 K/min 3 Pyrolysis temperature of 673–1073 K 4 Soaking time of 0.5–4.0 h	Raw materials for preparing activated carbons or adsorbents to apply in the removal of some organic and inorganic compounds from liquid and gas phases	Tsai <i>et al.</i> , 1998
33	Corn cob	Pyrolysis	The temperature was at 350–400°C	1 Xylan from corn cob is an additive in papermaking, textile printing and the pharmaceutical industry 2 Low-grade fuels	Cao <i>et al.</i> , 2004
34	Corn stover	Pyrolysis	High levels of temperature	Biomass feedstock	Green and Feng, 2006
35	Corn cob	Gasification	Temperature ranges of 500–800°C with less pollution characteristics of potassium hydroxide: potassium carbonate (KOH:K ₂ CO ₃) as chemical	Raw material for the preparation of activated carbon	Tsai <i>et al.</i> , 2001

(Continued)

Table 10.7 (Continued)

No	Substrate to be applied	Treatment methods	Physicochemical characteristics	Final products/uses	References
			agents and subsequent gasification at the soaking time of 1 h		
36	Corn starch	Gasification	The influence of process variables like temperature pressure, residence time and catalyst on supercritical water gasification of model compounds has been investigated	Feedstock	D'Jesus <i>et al.</i> , 2006
37	Corn cob	Chemical and physical activation	1 Chemical activation with potassium salts 2 Physical activation with CO ₂	Renewable source for energy production	Tsai <i>et al.</i> , 2001
38	Corn	Combustion and gasification	Carbon, hydrogen and mixed alcohols	Renewable fuels	Chum and Overend, 2001
39	Corn cob and corn tar	Combustion	Temperature range from 110 to 220°C	Burning oil of biomass (BOB)	Zhang and Wang, 2006
40	Corn	Combustion	Combustion was carried out in a high-pressure stainless steel oxygen bomb with a capacity of 340 ml	Renewable fuels	Souza <i>et al.</i> , 2002
41	Corn stover	Combustion	To minimize the effect of water in the biomass spectra, each sample was air-dried to less than 10% moisture prior to NIR spectroscopic analysis	Fuel or industrial feedstock	Pordesimo <i>et al.</i> , 2005
42	Corn oil	Biodiesel	The engine fueled with pure marine diesel fuel and blends containing two types of biodiesel, at proportions up to 50%	Alternative fuels	Kalligeros <i>et al.</i> , 2003
43	Corn	Ethanol and biodiesel production	Under relatively high prices for gasoline the costs for using ethanol and biodiesel are much higher per equivalent litre of gasoline	Alternative liquid fuels and ethanol production	Wesseler, 2006
44	Corn stover	Biodiesel and bioethanol	When corn stover is harvested, ethanol is produced from both corn stover and corn grain	Biofuels	Kim and Dale, 2005
45	Corn cob	Pyrolysis	Pyrolytic temperatures below 600°C	Liquid products of biomass	Cao <i>et al.</i> , 2004
46	Corn	Bioremediation	1 Varying pH (4.5–7.5) 2 Temperature between 35 and 55°C	1 Methane and hydrogen 2 Biofuels	Montgomery, 2004
47	Corn cob agrowaste	Chemical activation	1 Physical activation involves the carbonization of a carbonaceous precursor followed by	Renewable source for energy production	Chang <i>et al.</i> , 2000

			gasification of the resulting char in the presence of suitable oxidizing gasifying agents such as CO ₂ and steam at high temperatures		
			2 Chemical preparation with ZnCl ₂		
48	Corn husks	Enzyme preparation	1 pH 5.0 2 Temperature 50°C	Enzymatic production of soluble sugars	Hang <i>et al.</i> , 1998
49	Corn cobs	Enzyme preparation	1 Pretreated with NaOH 2 Followed by 48 h reaction 3 Temperature 50°C 4 pH 5.0	Enzymatic production of reducing sugars	Hang and Woodams, 2001
50	Corn stover	Chemical activation	Heat loss in a 1.26 m pipeline carrying 2 M dry tonnes/year is about 5°C	Production of ethanol and sugars	Kumar <i>et al.</i> , 2005
51	Corn stover	Radiation	Gamma irradiation of corn stover in combination with sodium hydroxide for bioconversion of polysaccharide	Fertilizer for the production of <i>Pleurotus</i> spp.	Gbedemah <i>et al.</i> , 1998
52	Corn hull and corn stover	Physical activation	Temperatures around 800°C	Activated carbon	Zhang <i>et al.</i> , 2004
53	Corn cob	Chemical activation	Many chemicals can be used as activators such as ZnCl ₂ , H ₃ PO ₄ , KOH, K ₂ CO ₃ , water vapor, CO ₂	Renewable fuels	Cao <i>et al.</i> , 2006
54	Rice straw	Composting	EC, pH were measured in the aqueous extracts of rice straw, oilseed rape cake, poultry manure and compost in a solid:distilled water of 1:20 (w/v dry weight basis)	Composting of rice straw with oilseed rape cake and poultry manure effects faba bean (<i>Vicia faba</i> L.) growth and soil properties	Abdelhamid <i>et al.</i> , 2004
55	Rice straw	Composting	1 Temperature, aeration, moisture and nutrients should be appropriately controlled 2 C/N ratio at 25–30 is the initial optimum ratio for composting	The mixture of swine manure with rice straw is used as fertilizer	Zhu, 2007
56	Rice flakes	Composting	1 (NH ₄) ₂ SO ₄ 4 mg/gds 2 MgSO ₄ 7H ₂ O 1 mg/gds 3 FeSO ₄ · 7H ₂ O 0.02 mg/gds 4 K ₂ HPO ₄ 1.4 mg/gds 5 KH ₂ PO ₄ 0.6 mg/gds 6 pH 7	Edible products	Anto <i>et al.</i> , 2006
57	Rice straw	Composting	1 The C/N ratios were the lowest (17–24) 2 A temperature of 62°C during 48 h removed pathogenic microorganisms from rice straw	Paper production, construction materials, incorporation in soil, compost, energy source, animal feed, etc.	Iranzo <i>et al.</i> , 2004

(Continued)

Table 10.7 (Continued)

No	Substrate to be applied	Treatment methods	Physicochemical characteristics	Final products/uses	References
58	Rice straw	Pyrolysis	1 Moisture 13.6% wt 2 Pyrolysis temperature of 400–800°C	Fuel gases, liquids and solids	Tsai <i>et al.</i> , 2006
59	Rice husk	Pyrolysis	Temperature 250–550°C	Source of thermal energy	Sharma and Rao, 1999
60	Rice husk	Pyrolysis	Temperature 1300–1500°C	Fuel gases	Martinez <i>et al.</i> , 2005
61	Rice straw	Pyrolysis	Moisture 7.1%wt	1 Raw material for paper industry, or as animal feed sources 2 Bio-oils	Putun <i>et al.</i> , 2004
62	Rice husk and straw	Combustion	The influence of different variables such as temperature, fluidization velocity on the combustion efficiency and CO emissions was investigated	Fuels	Armesto <i>et al.</i> , 2002
63	Rice husk	Combustion	1 Moisture 16.9%wt 2 Temperature is 340°C	Renewable fuels	Fang <i>et al.</i> , 2004
64	Rice straw	Combustion	Temperature 575°C	Fuel	Bakkera and Jenkins, 2003
65	Rice husk	Pyrolysis	The optimum temperature is 400°C	Fodder for livestock and industrial fuel for boilers	Maiti <i>et al.</i> , 2005
66	Rice husk	Combustion	1 Temperature ranging between 300 and 700°C 2 pH about 7	Renewable source of thermal energy	Liou, 2004
67	Rice husk	Combustion	Temperature range of 450–550°C	Liquid fuel	Zheng <i>et al.</i> , 2006
68	Rice straw	Biogas	1 2% formalin 2 0.1% KMnO ₄	Fertilizer for production of <i>Pleurotus sajor caju</i>	Banik and Nandi, 2004
69	Rice husk	Gasification	1 High moisture content (10.0% wt) 2 Low heating value (HHV 3450 kcal/kg)	Renewable source of energy	Lin <i>et al.</i> , 1999
70	Rice husk	Gasification	Temperature range of 200–1372°C	Fuel gas	Mansaraya <i>et al.</i> , 1999

References

Scientific references

- Abdelhamid, M.T., Horiuchi, T. and Oba, S. (2004). Composting of rice straw with oilseed rape cake and poultry manure and its effects on faba bean (*Vicia faba* L.) growth and soil properties. *Bioresource Technol* **93**, 183–189.
- Abd El-Nasser, N.H., Helmy, S.M. and El-Gammal, A.A. (1997). Formation of enzymes by biodegradation of agricultural wastes with white rot fungi. *Polymer Degrad Stabil* **55**, 249–255.
- Al-Masri, M.R. (2005). Nutritive value of some agricultural wastes as affected by relatively low gamma irradiation levels and chemical treatments. *Bioresource Technol* **96**, 1737–1741.
- Anshu, S. and Sharma, S. (2002). Composting of a crop residue through treatment with microorganisms and subsequent vermicomposting. *Bioresource Technol* **85**, 107–111.
- Anto, H., Trivedi, U.B. and Patel, K.C. (2006). Glucoamylase production by solid-state fermentation using rice flake manufacturing waste products as substrate. *Bioresource Technol* **97**, 1161–1166.
- Armesto, L., Bahilloa, A., Veijonenb, K., Cabanillasa, A. and Oteroa, J. (2002). Combustion behaviour of rice husk in a bubbling fluidised bed. *Biomass Bioenergy* **23**, 171–179.
- Arvanitoyannis, I.S. and Tserkezou, P. (2007a). Wheat, barley and oat waste: a comparative and critical presentation of methods and potential uses of treated waste. *Int J Food Sci Technol* (in press).
- Arvanitoyannis, I.S. and Tserkezou, P. (2007b). Corn and rice waste: a comparative and critical presentation of methods and current and potential uses of treated waste. *Int J Food Sci Technol* (submitted).
- Ayuso, M., Hernández, T., Garcia, C. and Pascual, J.A. (1996). Stimulation of barley growth and nutrient absorption by humic substances originating from various organic materials. *Bioresource Technol* **57**(3), 251–257.
- Bakker, R.R. and Jenkins, B.M. (2003). Feasibility of collecting naturally leached rice straw for thermal conversion. *Biomass Bioenergy* **25**, 597–614.
- Banik, S. and Nandi, R. (2004). Effect of supplementation of rice straw with biogas residual slurry manure on the yield, protein and mineral contents of oyster mushroom. *Indust Crops Prod* **20**, 311–319.
- Bhat, A., Bheemarasetti, J.V.R. and Rao, T.R. (2001). Kinetics of rice husk char gasification. *Energy Conversion Manage* **42**, 2061–2069.
- Blander, M. and Pelton, A.D. (1997). The inorganic chemistry of the combustion of wheat straw. *Biomass Bioenergy* **12**(4), 295–298.
- Bubenbeim, D.L., Patterson, M., Wignarajah, K. and Flynn, M. (1997). Incineration of biomass and utilization of product gas as a CO₂ source for crop production in closed systems: gas quality and phytotoxicity. *Adv Space Res* **20**(10), 1845–1850.
- Camarero, S., Bocchini, P., Galletti, G.C., Martinez, M.J. and Martinez, A.T. (2001). Compositional changes of wheat lignin by a fungal peroxidase analyzed by pyrolysis-GC-MS. *J Analyt Appl Pyrolysis* **58–59**, 413–423.

- Cao, Q., Xie, K.C., Bao, W.R. and Shen, S.G. (2004). Pyrolytic behaviour of waste corn cob. *Bioresource Technol* **94**, 83–89.
- Cao, Q., Xie, K.C., Lv, Y.K. and Bao, W.R. (2006). Process effects on activated carbon with large specific surface area from corn cob. *Bioresource Technol* **97**, 110–115.
- Caron, J. and Nkongolo, V.K.N. (1999). Aeration in growing media: recent developments. *Acta Hortic* **481**, 545–551.
- Chang, C.F., Chang, C.Y. and Tsai, W.T. (2000). Effects of burn-off and activation temperature on preparation of activated carbon from corn cob agrowaste by CO₂ and steam. *J Colloid Interface Sci* **232**, 45–49.
- Chum, H.L. and Overend, R.P. (2001). Biomass and renewable fuels. *Fuel Process Technol* **71**, 187–195.
- Conteras-Ramos, S.M., Alvarez-Bernal, D., Trujillo-Tapia, N. and Dendooven, L. (2004). Composting of tannery effluent with cow manure and wheat straw. *Bioresource Technol* **94**, 223–228.
- Cuiping, L., Chuangzhi, W., Yanyongjie and Haitao, H. (2004). Chemical elemental characteristics of biomass fuels in China. *Biomass Bioenergy* **27**, 119–130.
- Curreli, N., Benedetta Fadda, M., Rescigno, A. *et al.* (1997). Mild alkaline/oxidative pretreatment of wheat straw. *Process Biochem* **32**(S), 665–670.
- Davidsson, K.O., Pettersson, J.B.C. and Nilsson, R. (2002). Fertiliser influence on alkali release during straw pyrolysis. *Fuel* **81**, 259–262.
- Demirbas, A. and Sahin, A. (1998). Evaluation of biomass residue 1. Briquetting waste paper and wheat straw mixtures. *Fuel Process Technol* **55**, 175–183.
- Dieckow, J., Mielniczuk, J., González-Vila, F.J., Knicker, H. and Bayer, C. (2006). No-till cropping systems and N fertilisation influences on organic matter composition of physical fractions of a subtropical Acrisol as assessed by analytical pyrolysis (Py-GC/MS). *Geoderma* **135**, 260–268.
- D'Jesus, P., Boukis, N., Kraushaar-Czarnetzki, B. and Dinjus, E. (2006). Gasification of corn and clover grass in supercritical water. *Fuel* **85**, 1032–1038.
- Dresboll, D.B. and Thorup-Kristensen, K. (2005). Delayed nutrient application affects mineralisation rate during composting of plant residues. *Bioresource Technol* **96**, 1093–1101.
- Emtiazi, G. and Nahvi, I. (2000). Multi-enzyme production by *Cellulomonas* sp. grown on wheat straw. *Biomass Bioenergy* **19**, 31–37.
- Erhart, E., Hartl, W. and Putz, B. (2005). Biowaste compost affects yield, nitrogen supply during the vegetation period and crop quality of agricultural crops. *Europ J Agron* **23**, 305–314.
- Fan, M., Jiang, R., Liu, X. *et al.* (2005). Interactions between non-flooded mulching cultivation and varying nitrogen inputs in rice-wheat rotations. *Field Crops Res* **91**, 307–318.
- Fang, M., Yang, L., Chen, G., Shi, Z., Luo, Z. and Cen, K. (2004). Experimental study on rice husk combustion in a circulating fluidized bed. *Fuel Process Technol* **85**, 1273–1282.
- Faulds, C.B., Mandalari, G., Lo Curto, R.B., Bisignano, G., Christakopoulos, P. and Waldron, K.W. (2006). Synergy between xylanases from glycoside hydrolase family 10 and family 11 and a feruloyl esterase in the release of phenolic acids from cereal arabinoxylan. *Appl Microbiol Biotechnol* **71**, 622–629.
- Faulds, C.B., Mandalari, G., Lo Curto, R.B., Bisignano, G. and Waldron, K.W. (2006). Influence of the arabinoxylan composition on the susceptibility of mono- and

- dimeric ferulic acid release by *Humicola insolens* feruloyl esterases. *J Sci Food Agricult* **86**, 1623–1630.
- Fjellerup, J., Gjernes, E. and Hansen, L.K. (1996). Pyrolysis and combustion of pulverized wheat straw in a pressurized entrained flow reactor. *Energy and Fuels* **10**(3), 649–651.
- Franchini, J.C., Gonzalez-Vila, F.J. and Rodriguez, J. (2000). Decomposition of plant residues used in no-tillage systems as revealed by flash pyrolysis. *J Analyt Appl Pyrolysis* **62**, 35–43.
- Gabrielle, B., Da-Silveira, J., Houot, S. and Michelin, J. (2005). Field-scale modelling of carbon and nitrogen dynamics in soils amended with urban waste composts. *Agricult Ecosyst Environ* **110**, 289–299.
- Galletti, G.C., Bocchini, P., Guadalix, M.E., Almendros, G., Camarero, S. and Martinez, A.T. (1997). Pyrolysis products as markers in the chemical characterization of paperboards from waste paper and wheat straw pulps. *Bioresource Technol* **60**, 51–58.
- Gardea-Torresdey, J.L., Tiemann, K.J., Armendariz, V. *et al.* (2000). Characterization of Cr(VI) binding and reduction to Cr(III) by the agricultural byproducts of *Avena monida* (Oat) biomass. *J Hazard Mater* **B80**, 175–188.
- Gauthier, A., Derenne, S., Largeau, C. *et al.* (2003). Comparative study of ligno-cellulosic material from wheat straw and of pure and mixed standard compounds via solid state ¹³C NMR spectroscopy, conventional pyrolysis and TMAH thermochemolysis. *J Analyt Appl Pyrolysis* **67**, 277–293.
- Gbedemah, C.M., Obodai, M. and Sawyerr, L.C. (1998). Preliminary investigations into the bioconversion of gamma irradiated agricultural waste by *Pleurotus spp.* *Radiat Phys Chem* **52**, 379–382.
- Gleixner, G., Bol, R. and Bolesdent, J. (1999). Molecular insight into soil carbon turnover. *Rapid Commun Mass Spectrom* **13**(13), 1278–1283.
- Gokhale, D.V., Patil, S.G. and Bastawde, K.B. (1998). Potential application of yeast cellulase-free xylanase in agrowaste material treatment to remove hemicellulose fractions. *Bioresource Technol* **63**, 187–191.
- Green, A.E.S. and Feng, J. (2006). Systematics of corn stover pyrolysis yields and comparisons of analytical and kinetic representations. *J Analyt Appl Pyrolysis*, **76**, 60–69.
- Guerra-Rodriguez, E., Vazquez, M. and Diaz-Ravina, M. (2000). Co-composting of barley wastes and solid poultry manure. *Bioresource Technol* **75**, 223–225.
- Hammer, M.J. and Hammer, M.J. Jr (2004). *Water and wastewater technology*, 5th edn, p. 437. Pearson Educational International, New Jersey, USA.
- Hang, Y.D. and Woodams, E.E. (1999). Enzymatic production of soluble sugars from corn husks. *Lebensm-Wiss u-Technol* **32**, 208–210.
- Hang, Y.D. and Woodams, E.E. (2001). Enzymatic production of reducing sugars from corn cobs. *Lebensm-Wiss u-Technol* **34**, 140–142.
- Harrison, M.R. (2001). *Pollution causes, effects and control*, 4th edn, pp. 121, 129, 396, 398. Royal Society of Chemistry, London.
- Hernandez, M., Hernandez-Coronado, M.J., Montiel, M.D. *et al.* (2001). Pyrolysis: gas chromatography: mass spectrometry as a useful technique to evaluate the ligninolytic action of streptomycetes on wheat straw. *J Analyt Appl Pyrolysis* **58–59**, 539–551.
- Illerup, J.B. and Rathmann, O. (1997). CO₂ gasification of wheat straw, barley straw, willow and giganteus. *Fuel Energy Abstr* January.

- Iqbal, M.M., Akhter, J., Mohammad, W., Shah, S.M., Nawaz, H. and Mahmood, K. (2005). Effect of tillage and fertilizer levels on wheat yield, nitrogen uptake and their correlation with carbon isotope discrimination under rainfed conditions in north-west Pakistan. *Soil Tillage Res* **80**, 47–57.
- Iranzo, M., Canizares, J.V., Roca-Perez, L., Sainz-Pardo, I., Mormeneo, S. and Boluda, R. (2004). Characteristics of rice straw and sewage sludge as composting materials in Valencia (Spain). *Bioresource Technol* **95**, 107–112.
- Islam, M.N. and Ani, F.N. (2000). Techno-economics of rice husk pyrolysis, conversion with catalytic treatment to produce liquid fuel. *Bioresource Technol* **73**, 67–75.
- Jecu, L. (2000). Solid state fermentation of agricultural wastes for endoglucanase production. *Indust Crops Prod* **11**, 1–5.
- Jones, J.M., Pourkashanian, M., Williams, A. and Hainsworth, D. (2000). A comprehensive biomass combustion model. *Renewable Energy* **19**, 229–234.
- Kadam, K.L., Forrest, L.H. and Jacobson, W.A. (2000). Rice straw as a lignocellulosic resource: collection, processing, transportation, and environmental aspects. *Biomass Bioenergy* **18**, 369–389.
- Kalligeros, S., Zannikos, F., Stournas, S., Lois, E., Anastopoulos, G., Teas, C. and Sakellaropoulos, F. (2003). An investigation of using biodiesel/marine diesel blends on the performance of a stationary diesel engine. *Biomass Bioenergy* **24**, 141–149.
- Keeling, A.A., McCallum, K.R. and Beckwith, C.P. (2003). Mature green waste compost enhances growth and nitrogen uptake in wheat (*Triticum aestivum* L.) and oilseed rape (*Brassica napus* L.) through the action of water-extractable factors. *Bioresource Technol* **90**, 127–132.
- Kim, S. and Dale, B.E. (2004). Global potential bioethanol production from wasted crops and crop residues. *Biomass Bioenergy* **26**, 361–375.
- Kim, S. and Dale, B.E. (2005). Life cycle assessment of various cropping systems utilized for producing biofuels: bioethanol and biodiesel. *Biomass Bioenergy* **29**, 426–439.
- Koutinas, A.A., Wang, R. and Webb, C. (2004). Evaluation of wheat as generic feedstock for chemical production. *Indust Crops Prod* **20**, 75–88.
- Krings, U., El-Saharty, Y.S., El-Zeany, B.A., Pabel, B. and Berger, R.G. (2000). Antioxidant activity of extracts from roasted wheat germ. *Food Chem* **71**, 91–95.
- Krishnan, M.S., Taylor, F., Davison, B.H. and Nghiem, N.P. (2000). Economic analysis of fuel ethanol production from corn starch using fluidized-bed bioreactors. *Bioresource Technol* **75**, 99–105.
- Kumar, A., Cameron, J.B. and Flynn, P.C. (2005). Pipeline transport and simultaneous saccharification of corn stover. *Bioresource Technol* **96**, 819–829.
- Kwiatkowski, J.R., McAloon, A.J., Taylor, F. and Johnston, D.B. (2006). Modeling the process and costs of fuel ethanol production by the corn dry-grind process. *Indust Crops Prod* **23**, 288–296.
- Lanzetta, M. and Di Blasi, C. (1998). Pyrolysis kinetics of wheat and corn straw. *J Analyt Appl Pyrolysis* **44**, 181–192.
- Lima, J.S., De Queiroz, J.E.G. and Freitas, H.B. (2004). Effect of selected and non-selected urban waste compost on the initial growth of corn. *Resources Conservat Recyc* **42**, 309–315.
- Lin, S.H. and Lan, W.J. (1998). Treatment of waste oil/water emulsion by ultrafiltration and ion exchange. *Water Research* **32**(9), 2680–2688.

- Lin, K.S., Wang, H.P., Lin, C.J. and Juch, C.I. (1999). A process development for gasification of rice husk. *Fuel Process Technol* **55**, 185–192.
- Lin, Y.F., Jing, S.R. and Lee, D.Y. (2001). Recycling of wood chips and wheat dregs for sludge processing. *Bioresource Technol* **76**, 161–163.
- Liou, T.H. (2004). Evolution of chemistry and morphology during the carbonization and combustion of rice husk. *Carbon* **42**, 785–794.
- Liu, Y., Shengwei, Z. and Haoquan, H. (2000). Gasification of wheat straw for ammonia synthesis gas. *Coal Conversion* **23**, 92–95.
- Lynch, D.H., Voroneyb, R.P. and Warmanc, P.R. (2006). Use of ^{13}C and ^{15}N natural abundance techniques to characterize carbon and nitrogen dynamics in composting and in compost-amended soils. *Soil Biol Biochem* **38**, 103–114.
- Maiti, S., Dey, S., Purakayastha, S. and Ghosh, B. (2005). Physical and thermochemical characterization of rice husk char as a potential biomass energy source. *Bioresource Technol* **97**, 2065–2070.
- Mansaraya, K.G., Ghalya, A.E., Al-Taweelb, A.M., Hamdullahpurc, F. and Ugursal, V.I. (1999). Air gasification of rice husk in a dual distributor type fluidized bed gasifier. *Biomass Bioenergy* **17**, 315–332.
- Martinez, A.T., Camarero, S., Gutierrez, A., Bocchini, P. and Galletti, G.C. (2001). Studies on wheat lignin degradation by *Pleurotus* species using analytical pyrolysis. *J Analyt Appl Pyrolysis* **58–59**, 401–411.
- Martinez, V., Valencia, M.F., Cruz, J., Mejia, J.M. and Chejne, F. (2005). Production of β -SiC by pyrolysis of rice husk in gas furnaces. *Ceramics Int* **32**, 891–897.
- McLanaghan, S.R.B. (2002). Delivering the landfill directive: the role of new and emerging technologies. *Industrial Ecology*, Penrith, UK.
- Migliore, L., Brambilla, G., Casoria, P., Civitareale, C., Cozzolino, S. and Gaudio, L. (1996). Effect of sulphadimethoxine contamination on barley (*Hordeum distichum* L., Poaceae, Liliopsida). *Agricult Ecosyst Environ* **60**, 121–128.
- Montgomery, R. (2004). Development of biobased products. *Bioresource Technol* **91**, 1–29.
- Neves, L., Ribeiro, R., Oliveira, R. and Alves, M.M. (2006). *Enhancement of methane production from barley waste*. Elsevier, London.
- Nigam, J.N. (2000). Continuous ethanol production from pineapple cannery waste using immobilized yeast cells. *J Biotechnol* **80**, 189–193.
- Öhgren, K., Rudolf, A., Galbe, M. and Zacchi, G. (2006). Fuel ethanol production from steam-pretreated corn stover using SSF at higher dry matter content. *Biomass Bioenergy* **30**, 863–869.
- Olsson, M. (2006). Wheat straw and peat for fuel pellets – organic compounds from combustion. *Biomass Bioenergy* **30**, 555–564.
- Petts, and Eduljee (1994). *Environmental Impact Assessment for Waste Treatment and Disposal Facilities*. John Wiley and Sons Ltd. West Sussex, England, p. 485.
- Pordesimo, L.O., Hamesb, B.R., Sokhansanjc, S. and Edens, W.C. (2005). Variation in corn stover composition and energy content with crop maturity. *Biomass Bioenergy* **28**, 366–374.
- Putun, A.E., Apaydin, E. and Putun, E. (2004). Rice straw as a bio-oil source via pyrolysis and steam pyrolysis. *Energy* **29**, 2171–2180.

- Robinson, T., Chandran, B. and Nigam, P. (2002). Effect of pretreatments of three waste residues, wheat straw, corn cobs and barley husks on dye adsorption. *Bioresource Technol* **85**, 119–124.
- Rodriguez, J., Hernandez-Coronado, M.J., Hernandez, M., Bocchini, P., Gallettib, G.C. and Arias, M.E. (1997). Chemical characterization by pyrolysis/gas chromatography/mass spectrometry of acid-precipitable polymeric lignin (APPL) from wheat straw transformed by selected *Streptomyces* strains. *Analyt Chim Acta* **345**, 121–129.
- Saha, B.C., Iten, R.B., Cotta, M.A. and Wu, Y.V. (2005). Dilute acid pretreatment, enzymatic saccharification and fermentation of wheat straw to ethanol. *Process Biochem* **40**, 3693–3700.
- Schell, D.J., Riley, C.J., Dowe, N. *et al.* (2004). A bioethanol process development unit: initial operating experiences and results with a corn fiber feedstock. *Bioresource Technol* **91**, 179–188.
- Seungdo, K. and Dale, B.E. (2005). Environmental aspects of ethanol derived from no-filled com grain: nonrenewable energy consumption and greenhouse gas emissions. *Biomass Bioenergy* **28**, 475–489.
- Sharma, A. and Rao, T.R. (1999). Kinetics of pyrolysis of rice husk. *Bioresource Technol* **67**, 53–59.
- Shuangninga, X., Weimingb, Y. and Li, B. (2005). Flash pyrolysis of agricultural residues using a plasma heated laminar entrained flow reactor. *Biomass Bioenergy* **29**, 135–141.
- Singh, A. and Sharma, S. (2002). Composting of a crop residue through treatment with microorganisms and subsequent vermicomposting. *Bioresource Technol* **85**, 107–111.
- Souza, G.B., Carrilho, E.N.V.M., Oliveira, C.V., Nogueira, A.R.A. and Nobrega, J.A. (2002). Oxygen bomb combustion of biological samples for inductively coupled plasma optical emission spectrometry. *Spectrochim Acta Part B* **57**, 2195–2201.
- Swan, J.R.M., Crook, B. and Gilbert, E.J. (2002). Microbial emissions from composting sites. *Issues Environ Sci Technol* **18**, 73–102.
- Tchobanoglous, G., Burton, F.L. and Stensel, H.D. (2003). *Wastewater engineering treatment and reuse*, 4th edn. Mc Graw Hill, New York, USA.
- Thy, P., Jenkins, B.M., Leshner, C.E. and Grundvig, S. (2006). Compositional constraints on slag formation and potassium volatilization from rice straw blended wood fuel. *Fuel Process Technol* **87**, 383–408.
- Tsai, W.T., Chang, C.Y. and Lee, S.L. (1998). A low cost adsorbent from agricultural waste corn cob by zinc chloride activation. *Bioresource Technol* **64**, 211–217.
- Tsai, W.T., Chang, C.Y., Wang, S.Y., Chang, C.F., Chien, S.F. and Sun, H.F. (2001). Cleaner production of carbon adsorbents by utilizing agricultural waste corn cob. *Resources Conservat Recyc* **32**, 43–53.
- Tsai, W.T., Chang, C.Y., Wang, S.Y., Chang, C.F., Chien, S.F. and Sun, H.F. (2001). Preparation of activated carbons from corn cob catalyzed by potassium salts and subsequent gasification with CO₂. *Bioresource Technol* **78**, 203–208.
- Tsai, W.T., Lee, M.K. and Chang, Y.M. (2006). Fast pyrolysis of rice straw, sugarcane bagasse and coconut shell in an induction-heating reactor. *J Analyt Appl Pyrolysis* **76**, 230–237.
- Vane, C.H., Abbott, G.D. and Head, I.M. (2001). The effect of fungal decay (*Agaricus bisporus*) on wheat straw lignin using pyrolysis–GC–MS in the presence of tetramethylammonium hydroxide (TMAH). *J Analyt Appl Pyrolysis* **60**, 69–78.

- Vidmantienė, D., Juodeikiene, G. and Basinskiene, L. (2006). Technical ethanol production from waste of cereals and oats products using a complex enzyme preparation. *J Sci Food Agricult* **86**, 1732–1736.
- Vlaev, L.T., Markovska, I.G. and Lyubchev, L.A. (2003). Non-isothermal kinetics of pyrolysis of rice husk. *Thermochim Acta* **406**, 1–7.
- Vuorinen, A.H. and Saharinen, M.H. (1997). Evolution of microbiological and chemical parameters during manure and straw co-composting in a drum composting system. *Agricult Ecosyst Environ* **66**, 19–29.
- Vuorinen, A.H. (2000). Effect of the bulking agent on acid and alkaline phosphomonoesterase and β -D-glucosidase activities during manure composting. *Bioresource Technol* **75**, 133–138.
- Wesseler, J. (2006). *Opportunities (costs) matter: ethanol production using corn, switchgrass, and wood; biodiesel production using soybean and sunflower*. Elsevier, London.
- William, P.T. and Bagri, R. (2004). Hydrocarbon gases and oils from the recycling of polystyrene waste by catalytic pyrolysis. *Int J Energy Res* **28**, 31–44.
- Williams, P.T. (2005). *Waste treatment and disposal*, 2nd edn. John Wiley & Sons, Ltd, Chichester.
- Zafar, M.N., Nadeem, R. and Hanif, M.A. (2006). Biosorption of nickel from protonated rice bran. *J Hazard Mater* (in press).
- Zayed, G. and Abdel-Motaal, H. (2005). Bio-active composts from rice straw enriched with rock phosphate and their effect on the phosphorous nutrition and microbial community in rhizosphere of cowpea. *Bioresource Technol* **96**, 929–935.
- Zhang, H. and Wang, J. (2006). Combustion characteristics of a diesel engine operated with diesel and burning oil of biomass. *Renewable Energy* **31**, 1025–1032.
- Zhang, R. and Zhang, Z. (1999). Biogasification of rice straw with an anaerobic-phased solids digester system. *Bioresource Technol* **68**, 235–245.
- Zhang, T., Walawendera, W.P., Fana, L.T., Fanb, M., Daugaard, D. and Brown, R.C. (2004). Preparation of activated carbon from forest and agricultural residues through CO₂ activation. *Chem Engin J* **105**, 53–59.
- Zheng, J., Zhu, X., Guo, Q. and Zhu, Q. (2006). Thermal conversion of rice husks and sawdust to liquid fuel. *Waste Manage* **26**, 1430–1435.
- Zhu, N. (2007). Effect of low initial C/N ratio on aerobic composting of swine manure with rice straw. *Bioresource Technol* **98**, 9–13.

Electronic sources

<http://en.wikipedia.org/wiki/Grains>

<http://www.nutrition.org.uk/upload/Cereals%20pdf.pdf>

<http://www.face-online.org.uk/resources/factsheets/discovering/cereals.doc>

<http://www.historyworld.net/wrldhis/PlainTextHistories.asp?historyid=ab56>

<http://en.wikipedia.org/wiki/Wheat>

<http://en.wikipedia.org/wiki/Maize>

<http://en.wikipedia.org/wiki/Barley>

<http://en.wikipedia.org/wiki/Oat>

<http://en.wikipedia.org/wiki/Rice>

<http://www.geocities.com/napavalley/6454/cereals.html>
http://www.agrsci.dk/afdelinger/forskningsafdelinger/gbi/grupper/molekylaer_genetik_og_bioteknologi/cereals
<http://web.em.doe.gov/em30/wasttrea.html>
<http://www.epa.gov/epaoswer/osw/treattech.htm>
http://www.biffa.co.uk/files/pdfs/MassBalance_Agriwastes_08_Treatment.pdf
http://www.zazemiata.org/bw/radnevo/resume_ovos_en.pdf
<http://www.cpeo.org/techtree/ttdescript/pyrols.htm>
http://www.juniper.co.uk/services/Our_services/P&GFactsheet.html
<http://en.wikipedia.org/wiki/Pyrolysis>
<http://www.tab.fzk.de/en/projekt/zusammenfassung/AB49.htm>
<http://dbs.clib-jena.mpg.de/dbs-publ/pubi/bgc/BGC0130.pdf>
<http://www.biomatnet.org/secure/Fair/F538.htm>
<http://www.dynamotive.com/biooil/technology.html>
<http://www.pyne2005.inter-base.net/docs/PyNews%2017.pdf>
http://www.elsevier.com/wps/find/bookdescription.cws_home/600279/description#description
http://www.foe.co.uk/resource/riefings/gasifications_pyrolysis.pdf
<http://www.compost.org/pdf/ccc.rs.testing.compost.PDF>
http://www.remade.org.uk/organics/organics_documents/compostbenefitsscottishcrops.pdf
<http://www.formatkenya.org/ormbook/Chapters/chapter9.htm>
http://www.juniper.co.uk/services/Our_services/P&GFactsheet.html
<http://www.ecocentre.org.uk/biomass.html>
<http://en.wikipedia.org/wiki/Gasification>
<http://www.tab.fzk.de/en/projekt/zusammenfassung/AB49.htm>
<http://mitglied.lycos.de/cturare/fuel.htm>
<http://www.ecn.nl/docs/library/report/2000/c00080.pdf>
<http://mitglied.lycos.de/cturare/fue.htm#size>
<http://www.ecn.nl/docs/library/report/2000/c00080.pdf>
<http://mitglied.lycos.de/cturare/fue.htm#moisture>
<http://mitglied.lycos.de/cturare/fue.htm#form>
<http://mitglied.lycos.de/cturare/fue.htm#energy>
<http://www.esam.northwestern.edu/~matkowsky/fingering.html>
<http://www.eeci.net/archive/biobase/B10367.html>
<http://www.fao.org/sd/EGdirect/EGre0022.htm>
<http://www.ngvglobal.com/index.php?option=com-content&task=view&id=83&Itemid=2&lang=en>
<http://www.defra.gov.uk/ENVIRONMENT/consult/greenfuel/response/03.htm>
<http://www.miljolth.se/svenska/publikationer/visaInfo.asp?ID=222>
<http://www.fao.org/sd/EGdirect/EGre0022.htm>

Vegetable Waste Management: Treatment Methods and Potential Uses of Treated Waste

Ioannis S. Arvanitoyannis and Theodoros H. Varzakas

Introduction	703
Treatment methods	704
New waste management technologies	715
Identification of different compounds in vegetable waste	716
Comparison of waste treatment methods	730
Conclusions	752

Introduction

Fruit and vegetable wastes (FVW) are produced in large quantities in markets and constitute a source of nuisance in municipal landfills because of their high biodegradability (Misi and Forster, 2002). In the central distribution market for food (meat, fish, fruit, and vegetables) Mercabarna (Barcelona), the total amount of wastes coming from fruit and vegetables is around 90 tonnes per day for 250 days per year (Mata-Alvarez *et al.*, 1992). In India, FVW constitute about 5.6 million tonnes annually and currently these wastes are disposed of by dumping on the outskirts of cities (Srilatha *et al.*, 1995). In Tunisia FVW are estimated to be 180 tons per month (Bouallagui *et al.*, 2003).

According to Verrier *et al.* (1987) and Ruynal *et al.* (1998), the total initial solid concentration of FVW is between 8 and 18%, with a total volatile solids (VS) content of about 87% when anaerobic digestion was operated. The organic fraction includes about 75% sugars and hemicellulose, 9% cellulose and 5% lignin. The easily biodegradable

organic matter content of FVW (75%) with high moisture facilitates their biological treatment and shows the trend of these wastes for anaerobic digestion. However, complex vegetable processing effluent, such as olive mill wastes containing large amounts of phenolic and non-biodegradable compounds, are resistant to biological degradation (Hamdi, 1996). Aerobic processes are not favored for FVW treatment because they require preliminary treatment to minimize the organic loading rate.

The aim of this chapter is to make a comparative and critical presentation of all vegetable waste treatment methods (both traditional and novel) in an attempt to disclose the most effective and low cost methods. Moreover, the aim is to observe the advantages and drawbacks of each method separately.

Treatment methods

Vegetable processing industries are incriminated for a high quantity of pollution, hence, it is becoming very crucial to solve this problem by developing optimized systems for the treatment of vegetable wastes. Among the several processes that are being used nowadays, the ones described are the following: thermal processes, evaporation, membrane processes, anaerobic digestion, anaerobic co-digestion, biodiesel spraying, combustion, transesterification, coagulation and composting.

Waste can contain many re-usable substances of high value. Depending on there being an adequate technology, this residual matter can be converted into commercial products either as raw material for secondary processes, as operating supplies or as ingredients of new products. Numerous valuable substances in food production are suitable for separation and recycling at the end of their life cycle, even though present separation and recycling processes are not absolutely cost efficient.

Laufenberg *et al.* (2003) reported a literature survey, covering more than 160 articles from all over the world, plus their own investigations summarizing the latest knowledge in the field of vegetable waste and its transformation into value-added products and outlined prospects for future economic treatment of vegetable 'co-products'.

According to Laufenberg *et al.* (2003), the main goal of a clean production process is demonstrated by the following three practical implementations:

- 1 Upgrading of vegetable residues for the production of novel types of products: multifunctional food ingredients in fruit juice and bakery goods.
- 2 Bioconversion via solid-state fermentation: vegetable residues as an exclusive substrate for the generation of fruity food flavors.
- 3 Conversion of vegetable residues into operating supplies: bioadsorbents for wastewater treatment.

Regarding the vegetable industry, the main goals to be followed: waste reduction and recycling of valuable substances, by-products and residues; enlargement and adjustment of existing technology to the application area in particular (e.g. hybrid processes); development and application of new and efficient production processes; adding value

to by-products; step by step implementation of environmentally benign manufacturing; and development of 'innovative' products.

These goals could be fulfilled by the usual approaches such as minimization, disposal, feeding, fertilization/composting, closed loop production, or conversion. At present there are few possibilities for the utilization or recycling for most of these wastes, the residues are thus disposed of or fed to animals. Transport costs and sales problems due to the low quality of the residual matter have led to alternative utilization concepts, like use as a building material, or conversion concepts like composting and biogas production. Incineration has been largely investigated but not strongly pursued due to the low calorific value and high water content. An electric power station in Nimwegen, The Netherlands, has started to incinerate 40t of dried coffee grounds from an instant coffee production plant. Besides the low 'combustion' value, a critical point for all vegetable residues, the formation of off-odors bothering the nearby residents, appears to be another serious problem (Tagesschau, 1999).

Any recycling process will include the steps pretreatment (ensiling), drying, size deduction and fractionation. The overall recycling strategy, described in Figure 11.1, is designed in a modular manner, thus subdivided into substance characterization, definition of objectives, product and process design and application and optimization. The result is a final product which is optimized, a multifunctional food ingredient.

The first phase is mainly the substance characterization. Optimal recycling and application areas and possibilities are based on substance characterization. Particle classification, chemical analysis and physicochemical properties are the important steps. Following the definition of objectives, the desired properties of the future food ingredient as well as the food to be applied to will be investigated. Based on these 'key properties' advantages will arise for technological benefits, health or taste of a product.

Product and process design covers product and dispersion properties as well as their changes depending on the process parameters. Obvious examples are desirable or undesirable interactions between the food ingredients in general or during processing and interactions with surrounding and processing factors. The range of possible interactions is enormous, thus it is useful to obtain a concentration of the valuable ingredients as well as the desired technological, sensorial and physiological properties. A continuous control and improvement of the upgrading process and product can be gained by prototype development, definitions of partial qualities as well as incorporation of feedback circles.

At the application phase, the food product and newly designed food ingredient will be combined. At this interaction point the estimated use and practical application in a real food system meet each other. Quality related properties of the new product have to be assessed and compared with similar products already on the market. Hence a successful launch may be forecast (Laufenberg *et al.*, 2003).

Focused on the feeding concept there are further problems mentioned in the literature. Not every animal can consume every food/residue. Laufenberg *et al.* (1996) described that a protein concentrate made of potato fruit water could only be fed to cattle due to the high potassium content. Clemente *et al.* (1997) found that olive cake is not recommended for feeding because of its low digestibility. Sugarcane bagasse

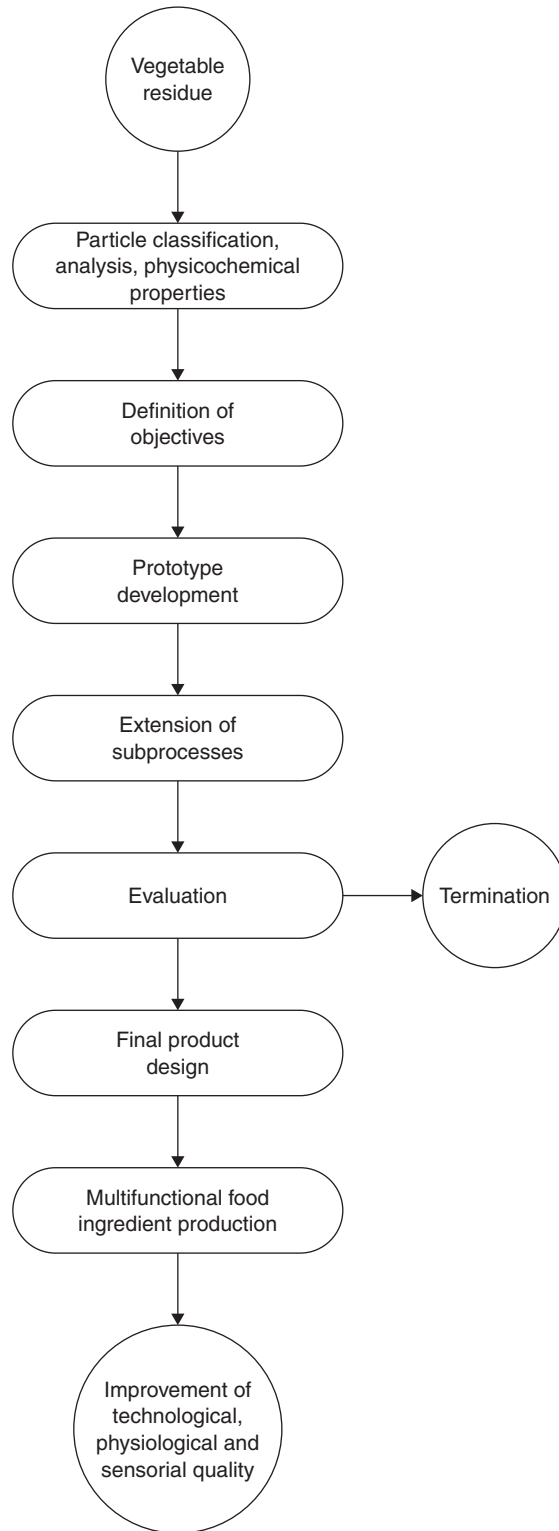

Figure 11.1 Strategy for the development of multifunctional food ingredients made of vegetable residues (the upgrading concept) (adapted from Henn, 1998; Laufenberg *et al.*, 2003)

has a high lignin content of 22%, which forms a protective association with cellulose, thereby causing low digestibility for animal foodstuff (Purchase, 1995).

Another branch for a further use of vegetable residues is their availability as a source of potential phytochemicals. Olive pomace is used as a nematode controlling agent for tomatoes (Rodriguez-Kabana *et al.*, 1995), citrus waste streams are used in horticulture (Widmer and Montanari, 1995) and mandarin peel flavonoids are interesting due to their fungistatic activity (Chkhikvishvili and Gogiya, 1995) which may be applied naturally to protect vegetables and fruits from molding. The limonoid compounds in citrus peel and seeds have recently been found to have important pharmacological properties as well as potential in the use as an insect antifeedant for agricultural crops (Manthey and Grohmann, 1996).

The raw material mostly used is carrot pomace (Ohsawa *et al.*, 1994, 1995; Henn and Kunz, 1996; Laufenberg *et al.*, 1996; Filipini and Hogg, 1997; Lucas *et al.*, 1997; Henn, 1998), followed by citrus waste (Sreenath *et al.*, 1995; Widmer and Montanari, 1995), grape or apple pomace (Carson *et al.*, 1994; Borycka, 1996; Lucas, 1997; Saura-Calixto, 1998; Masoodi and Chauhan, 1998), sugar beet pomace (Broughton *et al.*, 1995a, b; Koksel and Ozboy, 1999), orange, mango and apple peel (Larrauri, 1999), mango kernel flour (Arogba, 1999) (as a wheat flour substitute), potato peel (Toma *et al.*, 1979), sugarcane bagasse (Clarke, 1995) or mixtures of oat, rice, corn hulls and pea pods (Inglett, 1998). They are applied in pie fillings (Carson *et al.*, 1994), crackers (Carson *et al.*, 1994; Joshi and Sandhu, 1996), bread (Ohsawa *et al.*, 1994; Clarke, 1995; Filipini and Hogg, 1997; Lucas, 1997), cookies (Clarke, 1995; Koksel and Ozboy, 1999), beverages (Sreenath *et al.*, 1995; Henn and Kunz, 1996; Laufenberg *et al.*, 1996; Henn, 1998), jam (Grigelmo-Miguel and Martin-Belloso, 1999) and cakes, dressings and pickles (Ohsawa *et al.*, 1995). New approaches try to use the dietary fiber as a matrix for the encapsulation of antioxidants (Saura-Calixto, 1998) or flavors (Zeller, 1999), using both the physiological effects and the technological advantages in the form of a controlled release.

Flavor companies are nowadays interested in microscopically encapsulated aromas, which do not escape directly but under precisely defined circumstances, for example under mechanical stress such as chewing the chewing gum or at a certain temperature while baking cake mixtures (Stock, 1999; Schroder, 1999).

The selling prices for bioflavors are many times higher than the market prices for biotechnically produced bulk chemicals. Examples are of course fruity/flowery flavors like peach, rose or vanilla, but also for banana, produced by *Ceratocystis fimbriata* as a complex bioflavor with improved quality. The variety of vegetable residues as substrates could even be broadened by using co-cultures of microorganisms, called commensalism. *C. acetobutylicum*, for example, is unable to degrade cellulose but, in co-culture with a mesophilic cellulolytic *Clostridium* spp., even cellulose-enriched rice hulls, orange peel or sugar beet pulp could be metabolized (Duerre, 1998). Asther *et al.* (1997), Bonnin *et al.* (1999) and Lesage-Meessen *et al.* (1999) employed a co-culture of *Aspergillus niger* and *Pycnoporus cinnabarius* to transform ferulic acid from sugar beet pulp via vanillic acid into vanillin.

Ferulic acid was associated with the cell wall of very few dicotyledons, including sugar beets (0.36% related to dry weight) (Broughton *et al.*, 1995a, b; Couteau and

Mathaly, 1998) and many monocotyledons like wheat or maize (1–2% related to dry weight) (Asther *et al.*, 1997; Dexter and Wood, 1996). It is ester-linked to pectic side chains in beets and ether-linked to lignin in cereals. Besides sugar beet pulp, carrot pomace contains reasonable amounts of pectin and thus of ferulic acid. For olive press cake and corn cobs, a lignin content of approximately 35% indicates high precursor rates too. Remarkable amounts of ferulic acid are mentioned for palm press fiber by Prasertsan and Prasertsan (1996).

Almosnino and Belin (1991) described the use of the intrinsic enzyme system of apple pomace for the biotransformation of fatty acids into potential flavors. By means of these lipolytic enzymes, the precursors linoleic and linolenic acid were converted into alcohols and volatile aldehydes. A possible substrate to use instead of the precursors would be olive cake with its amounts of 74.0% oleic acid, 11.7% linoleic acid and 0.8% linolenic acid (Clemente *et al.*, 1997). Thus, a mixture of these residues would result in a useful substrate for a bioconversion of flavors. The addition of SO₂ and ascorbic acid, combined with micronization of the pomace, enhanced the flavor yield significantly up to 90%. The addition of ascorbic acid may be replaced by a lactic acid bacterial fermentation of the pomace, which will enhance shelf-life of the pomace and possibly flavor yield.

Besides the application as a texturing or gelling agent, the fat replacement function in diet food is an important advantage of fibers. Recently, new food additives have been developed on the basis of vegetable residues (Broughton *et al.*, 1995a, b; Inglett, 1998).

Vegetable pomace could also be utilized as a crude fiber ‘bread improver’ due to the high crude fiber content.

Carrot pomace works as a stabilizer in bread and bakery goods, as well as in pastry, cereals and dairy products. Some of its functional properties include crude fiber, richness in provitamins, color and natural acids, sourdough substitution in bread, acidifying agent, preservative or antioxidant in several food products (Toma, 1979; Ohsawa *et al.*, 1994, 1995; Filipini and Hogg, 1997; Lucas, 1997; Masoodi and Chauhan, 1998).

In beverages, carrot pomace or citrus waste will stabilize the natural color, improve the vitamin and fiber content, enhance the viscosity (mouthfeel) (Laufenberg *et al.*, 1996; Henn and Kunz, 1996; Henn, 1998) and enrich or adjust the cloudy appearance (Sreenath *et al.*, 1995). The organoleptic and chemical properties offer a widespread use in healthy and functional drinks and selected fruit juices.

Almond shell is the ligneous material forming the thick endocarp or husk of the almond tree (*Prunus dulcis* L.) fruit. Big ligneous fragments are separated following processing of the fruit to obtain the edible seeds. These materials remain available as a waste product for which no important industrial use has been developed, so they are normally incinerated. The almond tree is a common crop along the Mediterranean coast which is subsidized for economic and environmental reasons; this rain-fed crop is established normally on lands with no other agricultural use showing high potential risk of soil degradation. The total area all over the world was around 1 500 000 ha between 2000 and 2003 (FAO, 2001–2004).

Finding a use for waste materials, most of them locally produced, as soil-less growing media has been the subject of an important number of studies, especially as a peat alternative for ornamental potted plants (Ingelmo *et al.*, 1997; Offord *et al.*, 1998; Abad

et al., 2002), less frequently for vegetable production (Shinohara *et al.*, 1999; Ball *et al.*, 2000) and even for tomato transplant production (Ozores-Hampton *et al.*, 1999b).

Urrestarazu *et al.* (2005) reported that almond shell (100% pure) used as growing media can be more ecologically-friendly and less expensive than traditional rockwool since it can be locally produced. Three commercially produced random samples of two different textures and two volumes (19 and 25 l) were evaluated as growing media for soil-less production. Three experiments were conducted to evaluate the effects of volume and texture and to compare this substrate with rockwool in terms of yield and quality characteristics of fruits in melon and tomato culture. The physical, physico-chemical and chemical properties studied did not differ significantly between both textures. Tomato plants grown in almond shell residue used 21% less water compared to rockwool over the course of production. Significant differences of yield were found when the big size was used by Urrestarazu *et al.* (2005), especially in the melon crop where commercial yield and soluble solids of plants growing on 25 l bags was higher than that on the small one. The results suggested that almond shells seem to be an acceptable growing media as rockwool substitute for soil-less vegetable production.

Treatment of waste

Co-digestion with the organic fraction of municipal solid wastes (OFMSW) has been evaluated by Fernandez *et al.* (2005) for the treatment of fats of different origin. The process of co-digestion was conducted in a pilot plant working in the semicontinuous regime in the mesophilic range (37°C) and the hydraulic retention time (HRT) was 17 days. During the start-up period the digester was fed with increasing quantities of a simulated OFMSW (diluted dry pet food). When the designed organic loading was reached, the co-digestion process was initiated. The fat used consisted of animal fat waste from the food industry, with a similar long-chain fatty acid (LCFA) profile to that of the diluted dry pet food. Animal fat was suddenly substituted by vegetable fat (coconut oil) maintaining the organic loading. The LCFA profile for vegetable fat is completely different from that of animal fat and simulated OFMSW, short-chain-saturated LFCA being the most predominant (lauric acid, myristic acid and palmitic acid accounting for the 74% of the total LCFA content). No accumulation of LCFA or volatile fatty acids (VFA) was detected in either case. After a short adaptation period, total fat removal throughout the experiment was over 88%, whereas biogas and methane yields were very similar to those of simulated OFMSW. This proved to be an effective method and suitable technology for the treatment of waste through anaerobic co-digestion of OFMSW and fat wastes in order to obtain a renewable source of energy from biogas.

Anaerobic digestion technology can be competitive with aerobic systems, especially for treating industrial wastewater and organic solid wastes with high organic loading (Cavaleiro *et al.*, 2001).

Biodiesel, as an alternative fuel, has many merits. It is derived from a renewable, domestic resource, thereby relieving reliance on petroleum fuel imports. It is biodegradable and non-toxic. Compared to petroleum-based diesel, biodiesel has a more favorable

combustion emission profile, such as low emissions of carbon monoxide, particulate matter and unburned hydrocarbons. Carbon dioxide produced by combustion of biodiesel can be recycled by photosynthesis, thereby minimizing the impact of biodiesel combustion on the greenhouse effect (Agarwal and Das, 2001).

Four different continuous process flowsheets for biodiesel production from virgin vegetable oil or waste cooking oil under alkaline or acidic conditions on a commercial scale were developed by Zhang *et al.* (2003). Two of them were alkali-catalyzed processes, one using virgin oil and the other using waste cooking oil. The remaining two processes were acid-catalyzed processes using waste cooking oil as the raw material. Detailed operating conditions and equipment designs for each process were obtained. Stainless steel was used for the transesterification reactor in the designs for the alkali-catalyzed processes and the material of construction of other equipment in the alkali-catalyzed processes was carbon steel. For the acid-catalyzed system, stainless steel (type 316) reactor was used.

A technological assessment of these four processes was carried out to evaluate their technical benefits and limitations. Analysis showed that the alkali-catalyzed process using virgin vegetable oil as the raw material required the fewest and smallest process equipment units but at a higher raw material cost than the other processes. The use of waste cooking oil to produce biodiesel reduced the raw material cost. The acid-catalyzed process using waste cooking oil proved to be technically feasible with less complexity than the alkali-catalyzed process, thereby making it a competitive alternative to commercial biodiesel production by the alkali-catalyzed process.

The method using waste cooking oil was the most complex process with the greatest number of equipment pieces due to the addition of a pretreatment unit for free fatty acids removal despite the reduced raw material cost. The acid-catalyzed process using waste cooking oil had less equipment pieces than the previous process, but the large methanol requirement resulted in more and larger transesterification reactors, as well as a larger methanol distillation column. Methanol distillation was carried out immediately following transesterification to reduce the load in downstream units in this process but more pieces of equipment made from stainless steel material were necessary than for the first two processes. Acid-catalyzed process IV had the same merits and limitations as process III. However, the addition of hexane and methanol/water solvents increased the number of process equipment pieces and sizes of some separation units in process IV. In brief, for process simplicity, the alkali-catalyzed process using virgin vegetable oil is recommended. However, if raw material cost is of concern, the acid-catalyzed process using waste cooking oil (third process) is a relatively simple process and proved to be a competitive alternative to the first two processes (Zhang *et al.*, 2003).

Bouallagui *et al.* (2005) reviewed the potential of anaerobic digestion for material recovery and energy production from fruit and vegetable wastes (FVW) containing 8–18% total solids (TS), with total volatile solids (VS) content of 86–92%. The organic fraction includes about 75% easy biodegradable matter (sugars and hemicellulose), 9% cellulose and 5% lignin. Anaerobic digestion of FVW was studied under different operating conditions using different types of bioreactors. It permits the conversion of 70–95% of organic matter to methane, with a volumetric organic loading rate (OLR) of

1–6.8 g volatile solids (VS)/l day. A major limitation of anaerobic digestion of FVW is a rapid acidification of these wastes decreasing the pH in the reactor and a larger volatile fatty acids production (VFA), which stress and inhibit the activity of methanogenic bacteria. Continuous two-phase systems appear as more highly efficient technologies for anaerobic digestion of FVW. Their greatest advantage lies in the buffering of the organic loading rate taking place in the first stage, allowing a more constant feeding rate of the methanogenic second stage. Using a two-stage system involving a thermophilic liquefaction reactor and a mesophilic anaerobic filter, over 95% volatile solids were converted to methane at a volumetric loading rate of 5.65 g VS/l. The average methane production yield was about 420 l/kg added VS.

Tashtoush *et al.* (2003) investigated the feasibility of utilizing a renewable and low cost fuel raw material (a waste vegetable oil) as a diesel fuel replacement in small-scale applications such as in residential heating boilers. They examined the aspects of combustion performance and emissions of the ethyl ester of used palm oil (biodiesel) relative to the baseline diesel fuel in a water-cooled furnace. The combustion efficiency, η_c and exhaust temperature, T_{exh} , as well as the common pollutants and emissions were tested over a wide range of air/fuel ratios ranging from very lean to very rich (10:1–20:1). All tests were conducted at two different energy inputs for both fuels. The findings showed that, at the lower energy rate used, biodiesel burned more efficiently with higher combustion efficiency and exhaust temperature of, respectively, 66% and 600°C compared to 56% and 560°C for the diesel fuel. At the higher energy input, biodiesel combustion performance deteriorated and was inferior to diesel fuel due to its high viscosity, density and low volatility. As for emissions, biodiesel emitted fewer pollutants at both energy levels over the whole range of A/F ratio considered. World food consumption produces large quantities of waste (used or fryer) vegetable oil (WVO). In many world regions, most WVO produced is disposed of inappropriately. Consequently, this study was initiated to examine the potential of WVO as an alternative source of thermal energy.

In a vegetable oil industry, the effluent mainly comes from degumming, deacidification and deodorization steps in the refining of crude oil processing (Kale *et al.*, 1999). Blowdown of the boiler and wash water from the de-oiling of the bleaching earth also contribute to the effluent in small amounts. The wastewater varies both in quantity and characteristics from one oil industry to another. The composition of wastewater from the same industry also may vary widely from day to day (Chian and Dewalle, 1977). These variations can also be attributed to the different type of oils processed (Boyer, 1996).

Characteristic of the specific effluent, which might vary considerably for different refineries, is the high quantity of chemical oxygen demand (COD), oil and grease (OandG), sulfates, nitrogen and phosphates resulting in both high inorganic as well as organic loading of the respective wastewater treatment works. Moreover, vegetable oil refinery wastewater (VORW) is also known to contain chemical compounds like phenol, heavy metals from bleaching earth, catalyst used in the hydrogenation process and oxidizable substances. Also, pesticides used in growing the vegetable oilseed have been found in VORW (Chipasa, 2001). Physicochemical (skimming of oil, air flotation, flocculation, coagulation) for colloidal pollutants followed by biological processes for dissolved organics are the most commonly used techniques applied to VORW effluent. The

conventional biological processes, such as aerobic and anaerobic digestion, require a biochemical oxygen demand (BOD) to COD ratio to be 0.6. However, an effluent from the vegetable oil industry usually has a BOD/COD ratio around 0.2, which necessitates a proper pretreatment before the biological step (Chian and Dewalle, 1977).

Azbar and Yonar (2004) assessed the efficiency of alternative treatment processes in producing a final effluent conforming to regulatory standards with regards to COD and OandG (oil and grease) loads. The study was conducted in three principal stages: waste characterization, laboratory-scale treatability studies and full-scale applications. The effluents were characterized in terms of pH (6.3–7.2), total COD (13 750–15 000 mg/l), soluble COD (COD_s) (6500–7000 mg/l), BOD₅ (4300–4700 mg/l), OandG (3600–3900 mg/l), total suspended solids (TSS) (3800–4130 mg/l), total Kjeldahl nitrogen (TKN) (636–738 mg/l) and total phosphorus (TP) (61–63 mg/l). After analyzing various raw effluent parameters, laboratory-scale chemical treatability studies were conducted using Al₂(SO₄)₃·18H₂O and FeCl₃·6H₂O. The results showed 88 and 84% influent COD reduction, while OandG removal was 81 and 93%, respectively. The removal of TSS varied from 78 to 86%. Laboratory-scale aerobic biological treatment reactors with an HRT of 24 h and food to microorganism ratio of 0.3–0.5 were also run to assess the process efficiency and determine the residual soluble COD in the effluent. Residual soluble COD was 59–70 mg/l. Based on the results from waste characterization and treatability studies, a continuous full-scale treatment system was constructed and operated in two vegetable oil refining plants with a different pretreatment flow scheme. The overall percentage removal of COD, TSS, and OandG was 92–96, 83–98 and 93–95%, respectively.

De Neve *et al.* (2004) studied the possibilities of manipulating N mineralization from high N vegetable crop residues by the addition of organic materials, with the aim of initially immobilizing the mineralized residue N with a view to stimulating remineralization at a later stage. Residues of leek (*Allium porrum*) were incubated with soil, alone and in combination with straw, two types of green waste compost (with contrasting C:N ratios) and tannic acid. Evolution of mineral N was monitored by destructive sampling. After 15 weeks, molasses was added to part of the samples in each treatment and incubation continued for another 12 weeks. Molasses was added as a model substance for materials that strongly stimulate microbial activity in soil. The addition of molasses stimulated N mineralization only where compost₂ was added. The effect of the molasses here must have been a real priming effect and not a pool substitution effect, since the total net mineralization in the compost₂+M treatment was larger than the sum of net mineralization in the treatments where both modifiers (compost₂ and molasses) were added separately.

All materials added during the first incubation stage, except the low C:N compost, resulted in significant immobilization of the residue N. The immobilization with the high C:N compost (41.4 mg N/kg soil) was significantly larger than with tannic acid and straw (both immobilized about 26 mg N/kg soil). In the straw treatment, remineralization started in the first stage of incubation from day 50 onwards. The addition of molasses caused a strong and significant remineralization in the second stage (equivalent to 73% of the N initially immobilized) in the treatment with the high C:N ratio compost. In the case of tannic acid, there was no consistent effect on mineralization from the addition of molasses. This was attributed to the fact that the immobilization

observed was due to chemical rather than biological fixation of the residue N. A number of non-toxic organic wastes could be considered for use in mediating release of immobilized N from high N crop residue materials in an attempt to synchronize residue N availability with crop N demand.

The number of organic materials considered in this study was limited and a large variety of other organic materials could be considered. These include a number of organic wastes from the processing of agricultural produce, presently often land filled or incinerated. Olive oil mill waste is a typical material containing high polyphenol concentrations and could be applied instead of the tannic acid used as a model substance in this study. It is generally assumed that polyphenols in plant residues have the largest (negative) effect on N availability in the early stages of decomposition. Wastes from dairy industries or breweries can be expected to boost microbial activity in soil due to high concentrations of easily available organic C (De Neve *et al.*, 2003) and may have a similar effect as the molasses. However, great care should be taken that only those wastes that cause no risks with respect to environmental pollution due to the presence of toxic compounds are considered for this purpose.

Fruits and vegetable solid wastes (FVSW) represent a potential energy resource if they can be properly and biologically converted to methane. They are renewable and their net CO₂ contribution to the atmosphere is zero. Over 60×10^6 tons of fruits and vegetables are produced annually in India, of which only 1% is processed in the fruit and vegetable processing industries.

The biochemical methane potential of 54 fruit and vegetable waste samples and eight standard biomass samples were determined by Gunaseelan (2004) in order to compare extents and rates of their conversion to methane. The ultimate methane yields (B_0) and methane production rate of fruit wastes ranged from 0.18 to 0.732 l/g volatile solids (VS) added and 0.016 to 0.122/day, respectively, and that of vegetable wastes ranged from 0.19 to 0.41/g (VS) added and methane production rate ranged from 0.053 to 0.125/day, respectively. Temperature had no effect on the B_0 of mango peels, however, the conversion kinetics was higher at 35°C than at 28°C. All the samples of fruits and vegetable wastes tested gave monophasic curves of methane production. Substantial differences were observed in the methane yields and kinetics among the varieties in mango, banana and orange. Different fruit parts within the same variety showed different yields in orange, pomegranate, grape vine and sapota. The methane yields from some of the varieties of the mango peels, orange wastes, pomegranate rotten seeds and lemon pressings were significantly ($P < 0.05$) higher than the cellulose. Methane yields and kinetics of vegetable wastes in different varieties as well as within different plant parts of the same variety differed. Onion peels exhibited yields significantly ($P < 0.05$) similar to cellulose, while the majority of the vegetable wastes exhibited yields greater than 0.3 l/g VS. Rotten tomato, onion peels, pest infested brinjal, lady's finger stalk, coriander plant wastes, cabbage leaves, cauliflower stalk, turnip leaves, radish shoots and green pea pods exhibited methane yields greater than 0.3 l/g VS added. In coriander plant wastes, methane yield for leaves was higher than that of structural roots. These results provide a database on the extent and rates of conversion of fruits and vegetable solid wastes that significantly contribute to the organic fraction of municipal solid wastes (OF-MSW).

Bulluck *et al.* (2002) conducted field experiments to examine the effects of organic and synthetic soil fertility amendments on soil microbial communities and soil physical and chemical properties at three organic and three conventional vegetable farms in Virginia and Maryland (USA) in 1996 and 1997. Two treatments, including either an alternative organic soil amendment (composted cotton-gin trash, mixed yard waste-poultry litter compost, uncomposted cattle manure, or mixed hay-cattle manure compost) or synthetic soil amendment (fertilizer) were applied to three replicated plots at each grower field location. Production history and time affected propagule densities of *Trichoderma* species (known biological control agents, either found indigenously in soils or added to soils through the application of composted organic materials, as they are able to colonize compost quickly during curing) remained higher in soils from organic farms. Propagule densities of *Trichoderma* species, thermophilic microorganisms and enteric bacteria were also detected in greater numbers in soils amended with the alternative rather than the synthetic amendments, whereas propagule densities of *Phytophthora* and *Pythium* species were lower in soils amended with the alternative rather than the synthetic fertility amendments. Concentrations of Ca, K, Mg, and Mn were higher in soils amended with the alternative rather than the synthetic fertility amendments.

The use of waste food products for lead removal and the mechanisms of lead adsorption by such materials have not been investigated.

Coffee has become an established beverage in many parts of the world, including Europe, America and Japan, and large amounts of coffee grounds are discharged from the food industries. Although part of them is reused as compost and animal feed, most of the coffee grounds are burned as waste, which results in production of carbon dioxide, the greenhouse gas. Approximately 400 000 tons of coffee grounds are generated in Japan and 6 000 000 tons in the world. Developing technology to reuse coffee grounds for useful purposes would help convert this large amount of waste into a new resource.

Tokimoto *et al.* (2005) investigated the potential of reusing coffee grounds to remove hazardous lead ions from drinking water. In particular, they studied how the adsorption capacity of coffee beans and grounds for removing lead ion is correlated to such components as proteins, fat and caffeine. The rate of lead ion adsorption by coffee grounds was directly proportional to the amount of coffee grounds added to the solution. When coffee grounds were degreased or boiled, the number of lead ions decreased. When proteins contained in coffee grounds were denatured, the lead ion adsorption considerably reduced. The lead ion adsorption capacity of coffee grounds decreased with increased concentration of perchloric acid used for treating them and disappeared with 10% perchloric acid. The experiments demonstrated that proteins contained in coffee beans depended upon the adsorption of lead ion. The present study gave an affirmative answer to the possibility of using coffee grounds, an abundant food waste, for removing lead ions from drinking water. The present study demonstrated a way to reuse coffee grounds instead of incinerating them. It also suggested the possibility of using proteins contained in food waste for removing heavy metal ions occurring in drinking water.

New waste management technologies

The waste management strategy for future piloted space missions should meet the benefits of crewmembers' safety and respect the principles of planet ecology. Hence, new waste management technologies based on the application of the biodegradation properties of bacteria are applied.

The biological treatment method is based upon the biodegradation of organic substances by various microorganisms. Decomposition during composting occurs with air (aerobically) or during biogas processing without air (anaerobically) and results in reduction of any existing organic matter.

The advantages of biodegradation waste management are shown below:

- It diminishes the volume of organic wastes
- The biological hazard of the wastes will be controlled
- This system may be compatible with the other biological ELSS (greenhouses)
- The biogas created during biodegradation may be used for the other needs of the space vehicle (propellants) and
- The water obtained in the biodegradation processes may be used for the other needs of the space vehicle.

The solid waste treatment strategies of spaceflights are nowadays based on the principles of isolation, compression and storage. This mainly concerns feces, vomit, plastic, soft paper and cellulose swabs. This technology was implemented on orbital stations.

The objectives of the study reported by Ilyin *et al.* (2004) were the following:

- to evaluate the effectiveness of microbial biodegradation of non-pretreated substrate
- to construct and to test a pneumoautomatic digester for organic waste biodegradation
- to study microbial characteristics of active sludge samples used as inocula in the biodegradation experiment.

As an inoculate they used active sludge from a sewage water station and, as a substrate, disintegrated and water-suspended natural vegetable wastes and 'waste simulator', i.e. vegetable substrate of which the chemical content corresponds to that of original natural food wastes.

Their microbial studies of the biodegradation process revealed the following factors:

- 1 Gradual quantitative increase of *Lactobacillus* spp. (from 10^3 to 10^5 cfu/ml)
- 2 Activation of *Clostridia* spp. (from 10^2 to 10^4 cfu/ml) and
- 3 Elimination of aerobic conventional pathogens (*Enterobacteriaceae* spp., *Proteus* spp., staphylococci).

The results obtained by Ilyin *et al.* (2004) allowed the proposed technology to be effectively evaluated and determined the leading role of lactobacilli and clostridia in

the process of natural waste biodegradation. Further investigations should be based on synthesis of artificial inocula for launching food waste biodegradation. These inocula will include active and adapted strains of clostridia and lactobacilli.

Chromatography analysis revealed the constant presence of carbon dioxide (up to 90.9%). The methane content measures revealed traces 0.1–0.4%.

However, when they optimized the methane production in the ‘boiling layer’ using methanogenic granules, the amount of methane in biogas reached 80–90%.

Based on the results obtained, an artificial inoculum was created which was capable of initiating biodegradation of vegetable wastes. This inoculum consisted of active sludge adapted to wastes mixed with excreta of insects which consume plant wastes. Using this inoculum, the biodegradation process takes less time than that using active sludge. Regulation of methane concentration from traces to 90% may be achieved by adding methane reactor to the plant digester (Ilyin *et al.*, 2005).

A new approach to the waste treatment procedure, which switches on the biodegradation technologies of waste treatment of humans, was developed by ESTEC specialists (Project MELISSA). The Melissa (Microecological alternative LSS) was based on the microbial ecosystem and is dedicated to understanding the peculiarities of artificial ecosystems and also for the development of new biological LSS for piloted spacecraft and lunar bases. One of the key elements of the Melissa project is restoration of microbial mass from the wastes (feces, urine). The main version of the project concerns utilization of feces using commercial microbial strains. Three directions were investigated: proteolysis, saccharolysis and cellulolysis. However, up to now, the obtained level of biodegradation was considered to be too low for effective impact and was unsuitable for the fulfillment of tasks in the confined Melissa systems. Thus the decision was made to enlarge the effectiveness of the strains by selection of commensal strains. Moreover, the activity of the inoculum, formed by a consortium of bacteria obtained from the fermentation of fruits, garden and vegetable wastes, was measured. The latter gained high efficiency, however, the experiments are still ongoing. These data are of considerable interest, taking into consideration that it is the first attempt to implement biodegradation tools for waste treatment and because attention was also focused on plant food wastes, which may also form a sufficient part of wastes in future planning (due to LSS development).

Expected groups of wastes are the following:

- Physiological wastes
- Disposed personal hygiene effects
- Packaging of food products
- Plant residuals from greenhouse.

Identification of different compounds in vegetable waste

Rabaneda *et al.* (2003) used a new rapid and efficient method, combining liquid chromatography coupled to ionspray mass spectrometry in tandem mode with negative

ion detection, for the qualitative analysis of artichoke waste. Forty-five phenolic compounds were identified on the basis of their mass spectra in full scan mode, mass spectra in different MS–MS modes and retention times compared with those of available reference substances. The major compounds were found to be both caffeoylquinic and dicaffeoylquinic acids, luteolin glucuronide, luteolin galactoside, quercetin and some quercetin glycosides. Liquid chromatography coupled to MS proved to be a powerful tool to screen selectively artichoke by-product extracts for the occurrence of phenolics and structurally related substances. This would allow a better knowledge of both its chemical composition and its potential use as a source of natural antioxidants.

Artichoke (*Cynara scolimus*) is popular for its pleasant bitter taste, which is attributed to phytochemicals in the green parts of the plants. The presence of phytochemicals in artichoke has been well documented, the leaves being higher in medicinal value than flowers, with antihepatotoxic, choleric, diuretic, hypocholesterolemic and antilipidemic properties that are attributed to the phenolic composition. Spain is one of the major producers of artichoke in Europe and the canning industry is the most important consumer of this crop. The residues proceeding from this industry can form up to 60% of the harvested plant material, the final management of these wastes representing an additional problem. Until now, the common disposal of artichoke raw material is as organic mass, animal feed and fuel and fiber production.

Fluidized bed combustion

Fluidized bed combustion was shown to be a versatile technology capable of burning practically any waste combination with low emissions (Anthony, 1995). The significant advantages of fluidized bed combustors over conventional combustors include their compact furnace, simple design, effective burning of a wide variety of fuels, relatively uniform temperature and the ability to reduce emission of nitrogen oxide and sulfur dioxide gases. Fluidized bed combustors can be designed to combust almost any solid, semisolid or liquid fuel without the use of supplemental fuel, as long as the heating value is sufficient to heat up the fuel, drive off the moisture and preheat the combustion air. In addition, if operating procedures are followed and appropriate attention to fuel preparation and blending is given, wastes can be co-fired with coal in many existing coal-fired fluidized bed combustion boilers. Conversion of existing-fluidized bed combustion boilers to co-firing wastes with coal is in many cases more cost-effective and efficient than building a dedicated new unit (McGowin and Howe, 1994).

The combustion of three high moisture content waste materials (olive oil waste, municipal solid waste and potato) in a fluidized bed combustor was investigated by Suksankraisorn *et al.* (2003) and a comparison with co-firing of these materials with coal in the same combustor has been made. Mixtures of up to 20% mass concentration water in the waste were fed to the combustor. Above that value, the moisture content was too high to sustain combustion without the addition of coal. Measurements of CO, NO_x, SO₂ temperatures were taken and the carbon combustion efficiency evaluated. Co-firing

with coal resulted in markedly higher combustion efficiencies with an increase of approximately 10–80% when burning the simulated MSW. However, this was much lower than the value of 93% when coal was burnt on its own. It was also much lower than the value obtained, average 90%, when co-firing potato and olive oil waste with coal and there was little difference in the combustion efficiency between the two types of waste and with increasing moisture content.

Cliffe and Patsumsawad (2001) studied the co-firing of waste from olive oil production with coal in a fluidized bed combustor. They found that the carbon combustion efficiency of 10 and 20% olive oil waste mixed with coal were slightly lower than that of burning 100% coal. The carbon combustion efficiency dropped from 92 to 93% at 100% coal combustion to 90% at 10 and 20% olive oil waste mixed with coal. These carbon combustion efficiencies of 10 and 20% olive oil waste are the same as the carbon combustion efficiencies of 10 and 20% vegetable waste concentration. This might be that both the olive oil waste and vegetable waste have similar moisture and ash content, 60 and 5% on a dry basis, respectively.

Suksankraisorn *et al.* (2003) also concluded that the high ash content of the simulated MSW 26%, compared with 5% in the other two waste materials resulted in slower burning and consequently the char particles were elutriated from the bed without being fully burnt. In terms of gaseous emissions during co-combustion, CO emission is relatively insensitive to change in waste fraction, while emission of SO₂ can be reduced as the waste fraction increases as a result of fuel-S dilution. But in terms of percent fuel-S converted, it actually increased with an increase in waste fraction. Emissions of NO and N₂O increased slightly with MSW fraction. A fluidized bed combustion system is given in Figure 11.2.

Anaerobic digestion of vegetable waste

In anaerobic digestion, biomass waste is converted to biogas (by bacteria in the absence of oxygen) and compost. The biogas is mainly a mixture of CO₂ and CH₄. The biogas is partly utilized to heat the digestion reactors. The rest can be used to generate electricity and/or heat (e.g. with a gas engine) or, after treatment, be fed into the natural gas grid.

Anaerobic digestion of organic wastes to produce energy in the form of biogas is the most likely option to be of commercial interest, provided that the economics are favorable. The quantity of biogas produced as a function of the quantity of introduced raw material will be variable according to several factors, such as the quality of the organic matter and the environmental parameters. The intensity of the microbial activity on which the production of methane depends, is a function of the environmental temperature (Kettunen and Rintala, 1997).

Generally, the choice of a temperature range for anaerobic digestion is strictly dependent on the bioclimatic conditions. In Sweden, for example, research is currently underway for possible anaerobic digestion under low temperature conditions. In the USA, anaerobic digestion of sludge under thermophilic conditions has been abandoned, although it is well established in Europe, especially for the treatment of the organic fraction of municipal solid waste (Ahring *et al.*, 2002). In tropical countries, like Tunisia,

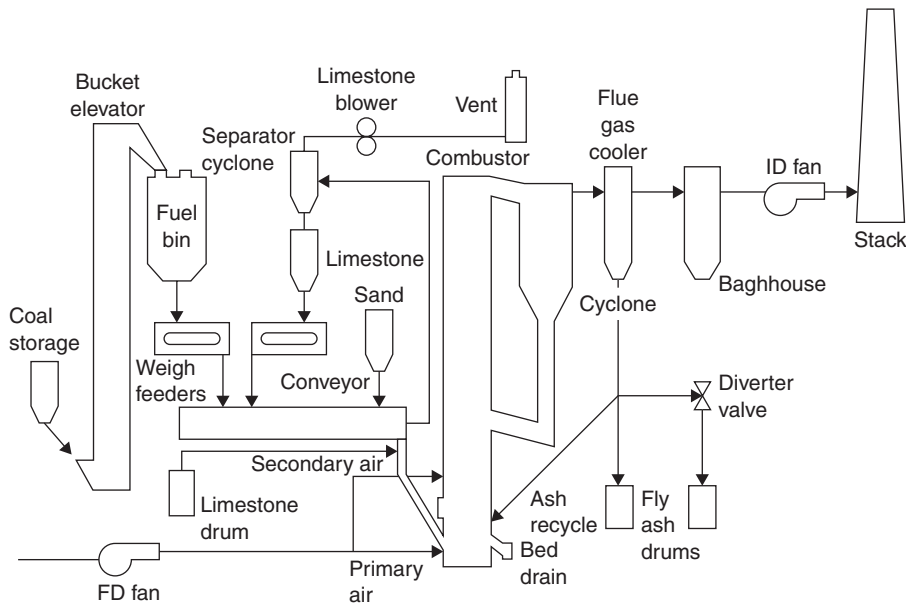

Figure 11.2 A fluidized bed combustion system (adapted from http://www.nrcan.gc.ca/es/etb/cetc/cetc01/htmldocs/factsheet_fluidized_bed_combustion_e.html)

where the ambient temperature is higher than 25°C for a period of more than 8 months in a year, thermophilic anaerobic digestion is readily applied.

Anaerobic digestion has many environmental benefits, including the production of a renewable energy carrier, the possibility of nutrient recycling and reduction of waste volumes. Many kinds of organic waste have been digested anaerobically in a successful way, such as sewage sludge, industrial waste, slaughterhouse waste, fruit and vegetable waste, manure and agricultural biomass. The wastes have been treated both separately and in co-digestion processes. In co-digestion, it is important to consider the effects of different incoming waste streams. Better handling and digestibility can be achieved by mixing solid waste with diluted waste. Furthermore, successful mixing of different wastes results in better digestion performance by improving the content of the nutrients and even reduces the negative effect of toxic compounds on the digestion process.

A recent review by Mata-Alvarez *et al.* (2000), demonstrated that the use of anaerobic digestion for the treatment of the organic fraction of municipal solid waste would reduce the emission of carbon dioxide. Therefore, in the light of the emission reductions agreed at the Kyoto Summit, environmental considerations may be of greater significance than economics. Fruit and vegetable waste (FVW) was also evaluated as a digester feedstock by a number of workers (Viswanath *et al.*, 1992) with a methane production of 0.37 m³/kg VS being reported. However, it has been suggested that the nitrogen and phosphorus in FVW can be low and this is one reason why it has also been used in co-digestions with other wastes, for example, chicken manure (CM) (Lane, 1984).

The digestion of cattle slurries and of a range of agricultural wastes was evaluated and has been successful according to Callaghan *et al.* (2002). Previous batch studies

have shown that, based on volatile solids (VS) reduction, total methane production and methane yield, co-digestions of cattle slurry (CS) with fruit and vegetable wastes (FVW) and with chicken manure (CM) were among the more promising combinations. A continuously stirred tank reactor (18l) was used as a mesophilic (35°C) anaerobic reactor to examine the effect of adding the FVW and CM to a system which was digesting CS (Callaghan *et al.*, 2002). The retention time was kept at 21 days and the loading rate maintained in the range 3.19–5.01 kgVS/m³/day. Increasing the proportion of FVW from 20% to 50% improved the methane yield from 0.23 to 0.45 m³ CH₄/kg VS added and caused the VS reduction to decrease slightly. Chicken manure was not as successful as a co-digestate. As the amount of CM in the feed and the organic loading was increased, the VS reduction deteriorated and the methane yield decreased. This appeared to be caused by ammonia inhibition.

Bouallagui *et al.* (2004) compared the performance of anaerobic digestion of fruit and vegetable waste (FVW) in the thermophilic (55°C) process with those under psychrophilic (20°C) and mesophilic (35°C) conditions in a tubular anaerobic digester on a laboratory scale. The aim of this study was to examine the effect of temperature on the anaerobic digestion of fruit and vegetable wastes (FVWs) for several retention times and feed concentrations and to compare the energy balance of the process under psychrophilic, mesophilic and thermophilic conditions. The hydraulic retention time (HRT) ranged from 10 to 20 days and raw fruit and vegetable waste was supplied in a semi-continuous mode at various concentrations of total solids (TS) (4, 6, 8 and 10% on dry weight). Biogas production from the experimental thermophilic digester was higher on average than from psychrophilic and mesophilic digesters by 144 and 41%, respectively. The net energy production in the thermophilic digester was 195.7 and 49.07 kJ per day higher than that for the psychrophilic and mesophilic digesters, respectively. The relation between the daily production of biogas and the temperature indicates that, for the same produced quantity of biogas, the size of the thermophilic digester can be reduced with regard to that of the psychrophilic and the mesophilic digesters.

The performance of an anaerobic digestion process is much dependent on the type and the composition of the material to be digested. The effects on the degradation process of co-digesting different types of waste were examined in two laboratory-scale studies (Murto *et al.*, 2004). In the first investigation, sewage sludge was co-digested with industrial waste from potato processing. The co-digestion resulted in a low buffered system and, when the fraction of starch-rich waste was increased, the result was a more sensitive process, with process overload occurring at a lower organic loading rate (OLR). In the second investigation, pig manure, slaughterhouse waste, vegetable waste and various kinds of industrial waste were digested. This resulted in a highly buffered system as the manure contributed very high amounts of ammonia. However, it is important to note that ammonia might be toxic to the microorganisms. Although the conversion of volatile fatty acids was incomplete, the processes worked well with high gas yields, 0.8–1.0 m³/kg VS.

The digester performance is highly sensitive to the quality of the feed of plant wastes, the yield and kinetics of the biological reaction involved in anaerobic digestion being strongly dependent upon waste composition. The reactor design also had a strong effect on digester performance.

As described above, co-digestion is of considerable technical interest, since it allows the use of existing installations and greatly increases biogas production and the energy produced in co-generation units. An additional advantage of the process is the obtaining of a valuable sludge which can be eventually used as a soil amendament subject to minor treatments.

Gómez *et al.* (2006) compared digestion of primary sludge (PS) against co-digestion of this waste together with the fruit and vegetable fraction of municipal solid wastes (FVFMSW), evaluating production of gas, the influence of mixing conditions and performance of the system under different organic loading rates. The anaerobic digestion process was evaluated under static conditions and with different mixing conditions. Good results (such as energy saving) were found for the digesters with limited mixing. The results for co-digestion of mixtures of PS + FVFMSW are better than those obtained from digestion of PS on its own. Biogas production for co-digestion is much greater thanks to the larger volatile solid (VS) content of this feedstock. Nevertheless, biogas yield and specific gas production for the two digestion processes are similar, with values in the range 0.6–0.8 l/g VS destroyed for the first parameter and in the range 0.4–0.6 l/g VS fed for the second. The co-digestion process was also evaluated at different organic loading rates (OLR) under low mixing conditions, with stable performance being obtained even when the systems were overloaded.

Anaerobic digestion can be carried out using three different systems: first, batch systems with the advantage of simple design and process control, robustness towards coarse and heavy contaminants and lower investment costs. Application of sequencing batch reactor (SBR) technology in anaerobic treatment of FVW is another batch system of interest due to its inherent operational flexibility, characterized by a high degree of process flexibility in terms of cycle time and sequence, no requirement for separate clarifiers and retention of a higher concentration of slow-growing anaerobic bacteria within the reactor (Dague *et al.*, 1992).

About 90% of the full-scale plants currently in use in Europe for the anaerobic digestion of organic fraction of municipal solid wastes and biowastes rely on continuous one-stage systems (Lissens *et al.*, 2001). However, a considerable amount of literature appeared concerning wastes treatment in two phases: first, an acid forming phase followed by a methanogenic phase (Sachs *et al.*, 2003). A likely reason for this discrepancy is that two- and multistage systems afford more possibilities for the researcher to control and investigate the intermediate steps of the digestion process. Industrialists, on the other hand, prefer one-stage systems because of their simpler designs and lower investment costs. Two-phase anaerobic digestion implies a process configuration employing separate reactors for acidification and methanogenesis connected in series, allowing optimization of both processes.

Post-treatments are necessary if anaerobic effluents need to be discharged into surface waters, because anaerobic digestion alone is not able to produce effluents that can meet the discharge standards applied in most industrialized countries, particularly for COD and nitrogen. The SBR technology can be successfully used for carbon and nitrogen removals with anoxic/aerobic processes. The anaerobic digestion of organic waste is shown in Figure 11.3.

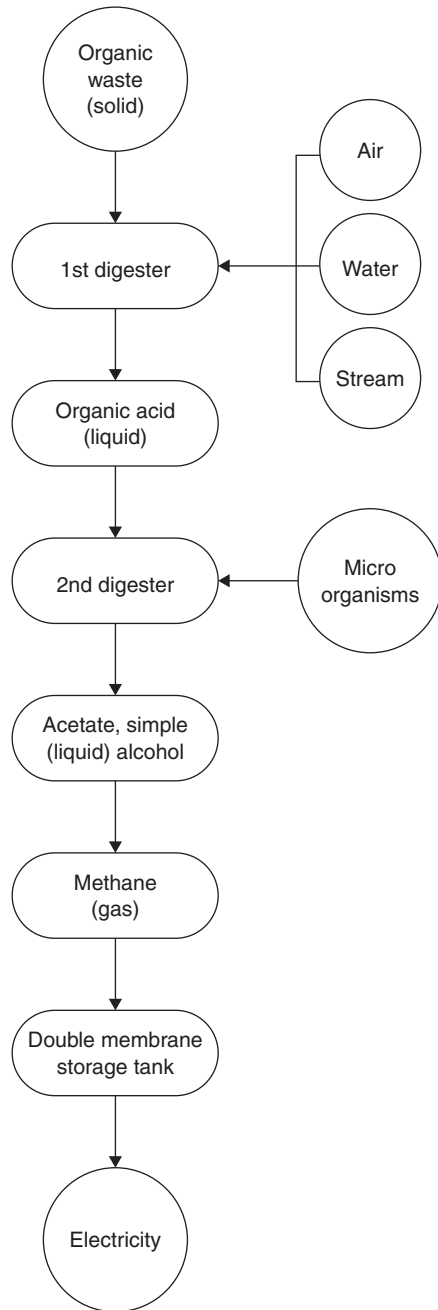

Figure 11.3 Anaerobic digestion of organic waste (adapted from http://www.mrc.wa.gov.au/resources/anaerobic_digestion.html)

Composting

Compost can act as an effective surface mulch, increase the concentration of soil organic matter, improve tilth and water-holding capacity, suppress weeds and provide

a long-term supply of nutrients as the organic material decomposes (Ozores-Hampton and Obreza, 1999a; Evanylo and Daniels, 1999). For these reasons, composting has been advocated as one component of sustainable agriculture (Edwards *et al.*, 2000).

Maintaining predictable compost quality is a particular problem when the material is produced from sources such as municipal solid waste (MSW), pulp mill solids or feedlot waste as a means of reducing an organic waste stream. In these operations, the process must be optimized for both efficiency of waste disposal and quality of end product, which demands that some compromise be made in both.

Most jurisdictions in North America and Europe have regulations stipulating the minimum quality standards which composts must meet for commercial sale (Baarth, 1999). Nevertheless, composts from different feedstocks or prepared by different methods can have significantly different chemical compositions even while meeting regulatory standards for nutrient content, maturity and physical composition. The chemical structure of the organic material in compost can vary in numerous ways that are non-linear and difficult to quantify. If these differences translate into difference in soil-amendment properties or fertilizer value, they hinder the expansion of compost use because the quality of different materials is unpredictable.

An important source of organic material for composting or soil restoration that is largely untapped is solid waste from the pulp and paper industry. Settled solids from the wastewater treatment plant of a typical pulp mill consist of expanded fibers of pulverized wood, rich in lignin and unused cellulose but low in soluble organic substances. Some nitrogen and phosphorus may be added during wastewater processing to speed decomposition.

Disposal of this material, variously referred to as clarifier solids or pulp mill sludge, presents a problem for the mill. Some of it may be incinerated, but the high water content impedes efficient combustion. Disposal by landfilling, the most common disposal method, is costly and faces increasingly stringent environmental regulations (Jackson *et al.*, 2000). Using settled solids as a soil amendment on farmland is an attractive alternative because it allows for some cost recovery, improves soil physical properties and recycles the carbon into the soil (Gagnon *et al.*, 2001).

A number of researchers have reported substantial benefits to physical characteristics of low-carbon soils from amendment with pulp mill solids or de-inking paper sludge. Benefits include increased organic matter content, augmented formation of macroaggregates, improved moisture-holding capacity and stimulated bacterial enzyme activity. The pulp mill solids may be biologically active, however, and their chemical composition may be unstable because decomposition is still actively proceeding. The carbon:nutrient ratios are likely to be high; the only significant N or P content is that which is added during wastewater treatment. These properties could cause unpredictable or detrimental effects on crops through phytotoxicity (Evanylo and Daniels, 1999) or immobilization of nitrogen (Simard *et al.*, 1998). Co-composting with a complementary high-nitrogen feedstock may relieve these deficiencies while maintaining the soil-building properties of the wood residues (Baziramakenga *et al.*, 2001).

Levy and Taylor (2003) examined the growth-promoting properties of compost produced from three very different feedstocks and composting processes, along with clarifier solids from a pulp mill that are currently being applied to farmland. They

compared the capacity of composts made from three different combinations of organic wastes (horse manure and bedding, mink farm wastes, municipal solid waste (MSW) and sewage sludge) along with clarifier solids from a chemo-thermomechanical pulp mill, to enhance the growth of tomato (*Lycopersicon esculentum* L.) seedlings grown in nutrient-poor organic potting soil. Germination and seedling emergence of tomatoes, cress (*Lepidium sativum* L.) or radish (*Raphanus sativus* L.) were tested to assess phytotoxicity of the four amendments. Their hypothesis was that chemical quality of the initial feedstocks would be reflected in the final products and hence predictable differences in early growth of a crop plant (tomato) would be produced from the different composts. They also hypothesized that the clarifier solids would prove less beneficial to plant growth than compost because of their instability and high carbon:nitrogen ratio. They suspected that phytotoxicity from clarifier solids might reduce their value as a soil amendment. They also concluded that application of pulp mill solids to agricultural soil without composting and without supplementing with inorganic nitrogen fertilizer may lead to deleterious effects on vegetable crops because of the potential for nutrient immobilization.

In Flanders, the selective collection of vegetable, fruit and garden waste (VFG) has grown steadily in the past decade. During the year 2000, 375 000 Mg of VFG waste were selectively collected and composted, representing an amount of 97 kg per head in regions with selective VFG collection. It is expected that more regions will adopt the selective collection system in the near future to reduce the organic fraction of household wastes. As a result, the amount of available VFG compost keeps growing. A similar situation occurs in other EU countries. Because other sectors can absorb only limited extra quantities of this VFG compost, agriculture and horticulture are considered potential 'markets'.

However, in order to minimize the losses of nitrates (NO_3^-) from agricultural surface to ground or surface water, the Flemish manure legislation ('Manure Action Plan', MAP) limits the inputs of nutrients (particularly N) on grassland and arable land. For silage maize, the limit of N fertilization is 275 kg N/ha/year, but it is not allowed to supply more than 250 kg N/ha/year from organic fertilizers. In the MAP, composts and manures are both treated as organic fertilizers; differences in N release of both types of organic amendments are not (yet) taken into account. Considering the high stocking density in Flemish agriculture and hence an exuberant availability of manure and slurry, farmers preferentially use their own produced organic fertilizers (within the legal limits) on their arable land as well as on their grasslands. Furthermore, little knowledge on the potential advantages of compost in agricultural practice is present.

Nevertheless, it has clearly been established that composts have potential to protect the soil against erosion (Bazzoffi *et al.*, 1998), to enhance the soil water retention (Bengston and Cornette, 1973; Mays *et al.*, 1973), to reduce soil compactibility (Bazzoffi *et al.*, 1998), to decrease soil acidity (Duggan and Wiles, 1976), to enhance soil biochemical (Giusquiani *et al.*, 1995) and biological activity (Pfozter and Schüler, 1997) and to establish a sound soil ecological equilibrium (Stickelberger, 1977). Additionally, composts can protect plants from soil (Alvarez *et al.*, 1995) or seed borne pathogens (Schüler *et al.*, 1993). Hence, compost can be considered a much-needed

soil conditioner (He *et al.*, 1992) with generally positive crop yield effects (Gallardo-Lara and Nogales, 1987). Only too high doses of urban waste compost (100 Mg/ha or more, depending on the chemical composition) can lead to toxic amounts of heavy metals in plants (Mays *et al.*, 1973), a possible negative drawback. However, selective collection of the organic fraction of household wastes results in VFG compost, a product with substantially lower contents of heavy metal.

Compost is known to be nutrient rich and the generally high application rates imply a considerable import of nutrients into the soil. Considering the current concern about groundwater contamination, a precise knowledge of the nutrient availability in highly matured composts is particularly important (Iglesias-Jiménez and Alvarez, 1993).

The pattern of N availability of highly matured compost is a positive net mineralization. However, a considerable amount of N in composts is tied up in an organic form and is only slowly released over a period of years (Diener *et al.*, 1993). As a result, a low plant use efficiency of compost-N is observed (Brinton, 1985; Iglesias-Jiménez and Alvarez, 1993). As a result, the risk of excessive nitrate leaching would only exist at high compost application rates (100 Mg/ha or more).

Nevens and Reheul (2003) tested the possibility of applying GFT compost in a typical management of silage maize cropping in Flanders: the crop is often grown in a monoculture, with a yearly spring application of slurry and an additional application of mineral fertilizer N. They combined an average yearly cattle slurry application (about 40 Mg/ha) and added a moderate yearly vegetable fruit and garden waste (VFG) compost application (22.5 Mg/ha). They studied the compost effect on silage maize DM yield and N uptake and determined the possible saving of additional mineral N owing to the slurry and/or compost application. They also measured the amounts of residual mineral soil N to estimate the possible threats of compost and/or slurry use for excessive nitrate leaching. Silage maize N uptake and N concentration in maize were higher when compost was applied. Despite the low N output/input rate with compost application, it did not result in an excessive amount of residual soil nitrate-N, provided that the additional mineral fertilizer N was adapted to the economic optimum level. Compared to slurry application, 4 years of VFG compost application resulted in significantly higher soil organic matter and total nitrogen concentrations.

Biodiesel uses

Biodiesel (vegetable oil methyl esters) can be used as biological solvents (Von Wedel, 1997) and vegetable oil methyl esters biodiesel, may remove twice the amount of oil from sand compared to conventional shoreline cleaners (Page *et al.*, 2000). Biodiesel has drawn attention as a non-toxic, biodegradable and renewable source of energy. Additional environmental benefits also include lower exhaust emissions of particulate matter and greenhouse gases such as CO, CO₂ and SO_x. Large quantities of biodiesel can be produced at low cost, making it a less expensive countermeasure. Furthermore, vegetable oil methyl esters are significantly less toxic than crude oils towards a widerange of algae, macrophytes and animals and are also rapidly degradable in the environment (Zhang *et al.*, 1998). The mixture of biodiesel–oil at the water surface can

be collected with conventional booms and skimmers deployed in advance to collect the mixture, which can then be recycled as burner fuel or reprocessed at an oil refinery.

Pereira and Mudge (2004) carried out laboratory experiments to investigate further the potential of vegetable oil biodiesels to clean up different types of oiled shore sediments. Batch experiments showed that biodiesel had a considerable capacity to dissolve crude oil, which appeared to be dependent on the type of biodiesel used. Pure vegetable oil biodiesels (rapeseed and soybean) were significantly more effective in the cleanup of oiled sands (up to 96%) than recycled waste cooking oil biodiesel (70%). In microcosm and mesocosm experiments, oiled sediments were sprayed with biodiesel and subjected to simulated tides. Microcosm experiments revealed that the highest ratio of 2:1 (biodiesel to crude oil) had the highest effectiveness for cleaning fine sands. In the mesocosm experiments, a ratio of 1:1 (soybean biodiesel to crude oil) removed 80% of the oil in cobbles and fine sands, 50% in coarse sand and 30% in gravel. Most of the oil was removed with the surface water, with only a small amount being flushed through the sediments. Particle size and pore size were important determinants in the cleanup and mobility of crude oil in sediments in these static systems. It is expected that the biodiesel effectiveness should improve in the natural environment, particularly in exposed beaches with strong wave action.

Waste vegetable oils and non-edible crude vegetable oils are preferred as potential low priced biodiesel sources. In addition, it is possible to use soapstock, a by-product of edible oil production, for cheap biodiesel production.

Usta *et al.* (2004) produced a methyl ester biodiesel from a hazelnut soapstock/waste sunflower oil mixture using methanol, sulfuric acid and sodium hydroxide in a two-stage process. Soapstock contains large amounts of free fatty acids (45–50%). The effects of the methyl ester addition to diesel on the performance and emissions of a four cycles, four cylinder and turbocharged indirect injection (IDI) diesel engine were examined at both full and partial loads. Experimental results showed that the hazelnut soapstock/waste sunflower oil methyl ester can be partially substituted for the diesel fuel at most operating conditions in terms of the performance parameters and emissions without any engine modification and preheating of the blends.

Haas *et al.* (2000) produced fatty acid methyl esters (FAME) from soybean soapstock in a two-stage process that involved alkaline hydrolysis of all lipid linked fatty acid ester bonds and acid catalyzed esterification of the resulting fatty acid sodium salts. It was reported that the specifications of the FAME met the current specifications for biodiesel. In addition, Haas *et al.* (2001) tested the biodiesel produced from soybean soapstock in a diesel engine. They determined reductions in the emissions of total hydrocarbons, particulates and carbon monoxide by means of combustion of the neat soapstock biodiesel. Haas *et al.* (2003) also produced FAME from soapstock using only acid catalyzed esterification. It was reported that maximum esterification occurred at 65°C and 26 h reaction at a molar ratio of total fatty acid (FA)/methanol/sulfuric acid of 1:15:1.5.

Transesterified vegetable oils (VOs) are a promising alternative diesel fuel. Waste VOs are cheap and renewable but currently disposed of inadequately. Al-Widyan and Al-Shyokh (2002) transesterified waste palm oil under various conditions. Transesterification is a common and well-established chemical reaction in which linear monohydroxy alcohols react with VOs, which are triglycerides of fatty acids, in

the presence of a catalyst. The alcohol may be butanol, methanol or ethanol, while the catalyst may be basic or acidic. The products of the process are alcohol esters of VOs with glycerine as a by-product.

Sulfuric acid and different concentrations of HCl and ethanol at different excess levels were used. Higher catalyst concentrations (1.5–2.25 M) produced biodiesel with lower specific gravity, γ , in a much shorter reaction time than lower concentrations. The H_2SO_4 performed better than HCl at 2.25 M, as it resulted in lower γ . Moreover, a 100% excess alcohol effected significant reductions in reaction time and lower γ relative to lower excess levels. The best process combination was 2.25 M H_2SO_4 with 100% excess ethanol which reduced γ from an initial value of 0.916 to a final value of 0.8737 in about 3 h of reaction time. The biodiesel had the behavior of a Newtonian fluid.

In order to make the biodiesel price competitive and to expand its usage, production of biodiesel fuel using substrates at a low price is a good alternative. Potential substrates comprise lard, tallow and vegetable oils from restaurants and household disposals. Waste vegetable oil from crude oil refining industries is also a suitable substrate for biodiesel production. Large amounts of activated bleaching earth (ABE) containing nearly 40% of its weight as waste oil are discarded every day. Japan alone annually produces more than 50 000 metric tonnes. Lara Pizarro and Park (2002) focused on the production of fatty acid methyl esters using vegetable oil extracted from waste ABE by enzymatic treatment. A commercially available lipase from *Rhizopus oryzae* (acylglycerol acylhydrolases, EC 3.1.1.3), an enzyme that hydrolyzes the ester bonds in tri-, di-, and monoacylglycerols, was selected to carry out the conversion of triglycerides into their respective methyl esters in a water containing system. Lipases are versatile catalysts and the reaction can be carried out with or without organic solvent. Interest increased nowadays in methyl and ethyl esters as partial substitutes for diesel fuel. Methanolysis was efficiently catalyzed by *Rhizopus oryzae* lipase in the presence of high water content and by a single addition of methanol. *R. oryzae* lipase was not inactivated by methanol in concentrations lower than 4 milli-equivalents and 75% water content. Optimum conditions for methanolysis of extracted oils were 75% water content (by weight of substrate), an oil/methanol molar ratio of 1:4, and 67 IU/g of substrate with shaking of 175 rpm for 96 h at 35°C. The highest conversion yield reached 55% (w/w) with palm oil after 96 h of reaction. Adverse viscosity conditions might have influenced methanolysis of extracted soybean and rapeseed oil in spite of high water or methanol concentrations.

Recently, lipase catalyzed production of biodiesel from sunflower (Mittelbach, 1990), soybean oil (Kaieda *et al.*, 1999), mixture of vegetable oils (Watanabe *et al.*, 2000), grease and tallow (Nelson *et al.*, 1996), palm oil kernel and coconut oil (Abigor *et al.*, 2000) and rice bran oil (Kamini and Iefuji, 2001) with primary or secondary alcohols has been reported.

Park and Ming (2004) studied the long-term behavior of rapeseed oil in waste activated bleaching earth (ABE) and the effect of this oil on riboflavin production in the culture of *Ashbya gossypii*. Waste ABE with 40% (w/w) rapeseed oil was stored for 80 days and the extent of oxidation of rapeseed oil was measured with several analytical methods to determine the chemical properties of the oil at different stages of the

oil deterioration process: peroxide value, acid value, concentrations of organic acids, acetaldehyde and unsaturated fatty acid and content of polymerized triglycerides. Biological treatment of the solid waste containing vegetable oil has not been reported yet. Hence, the conversion of vegetable oils in waste ABE into useful value-added bioproducts, e.g., riboflavin, using oil-utilizing microorganisms has been reported by Park and Ming (2004). Nowadays, genetically engineered microorganisms using glucose as a carbon source are used to increase the riboflavin production rate. However, to reuse waste vegetable oil, they cultured *Ashbya gossypii* using the waste vegetable oil as a sole carbon source and found that the vegetable oils in waste ABE were useful in producing the riboflavin.

Peroxide value, acid value and concentrations of organic acids and acetaldehyde did not affect riboflavin production. However, the content of polymerized triglycerides markedly increased the viscosity of rapeseed oil and was the main reason for the exponential decrease in riboflavin production. A good correlation between the polymerized triglyceride content or viscosity and riboflavin production in the culture of *A. gossypii* using rapeseed oil as the sole carbon source was found.

Pugazhvadivu and Jeyachandran (2005) reported the use of waste frying oil, sunflower oil, a non-edible vegetable oil, as an alternative fuel for diesel engines. The high viscosity of the waste frying oil was reduced by preheating. The properties of waste frying oil, such as viscosity, density, calorific value and flash point were determined. The effect of temperature on the viscosity of waste frying oil was evaluated. It was determined that the waste frying oil requires a heating temperature of 135°C to bring down its viscosity to that of diesel at 30°C. The performance and exhaust emissions of a single cylinder diesel engine were evaluated using diesel, waste frying oil (without preheating) and waste frying oil preheated to two different inlet temperatures (75 and 135°C). The engine performance was improved and the CO and smoke emissions were reduced using preheated waste frying oil. It was concluded that the waste frying oil preheated to 135°C could be effectively used as a diesel fuel substitute for short-term engine operation.

Dmytryshyn *et al.* (2004) studied the transesterification of four vegetable oils: canola oil, greenseed canola oil from heat-damaged seeds, processed waste fryer grease and unprocessed waste fryer grease, which was carried out using methanol, and KOH as catalyst. The methyl esters of the corresponding oils were separated from the crude glycerol, purified and characterized with various methods to evaluate their densities, viscosities, iodine values, acid numbers, cloud points, pour points and gross heat of combustion, fatty acid and lipid compositions, lubricity properties and thermal properties. The lipid composition of the methyl esters was determined using HPLC. The GPC method used was the low molecular weight gel permeation chromatography. The fatty acid compositions of the methyl esters were measured by gas chromatography using a GC equipped with a DB-FFAP column and flame ionization detector.

The fatty acid composition suggests that 80–85% of the ester was from unsaturated acids. A substantial decrease in density and viscosity of the methyl esters compared to their corresponding oils suggested that the oils were in their mono- or diglyceride form. The lubricity of the methyl esters, when blended at 1 vol% treat rate with ISOPAR® M reference fuel, showed that the canola methyl ester enhanced the fuel's lubricity number.

From the analyses performed, it was determined that the ester with the most potential for being an additive or a substitute for diesel fuel is the canola methyl ester, whose physical and chemical characteristics are similar to diesel fuel.

Confined animal feeding operations

Confined animal feeding operations (CAFOs) are a source of agricultural pollution and pose risks to water quality and public health due to the large amount of manure generated (USEPA, 1998). The US Environmental Protection Agency (EPA) estimates that animal waste production in 1992 was 13 times greater on a dry weight basis than human production. Sources of water pollution from CAFOs include direct discharges, open feedlots, treatment and storage lagoons, manure stockpiles and land application of manure. Pollution of surface flow and groundwater from animal waste applied to soils has been documented (Mallin *et al.*, 1997). Liquid-waste discharges onto soil initiates solute and microbe movement into the soil following groundwater drainage patterns and can potentially contaminate adjoining surface water. These water bodies are often sources of drinking water or are used for recreational activities. Human contact with recreational waters containing intestinal pathogens is an effective method of disease transmission. Thus, employing appropriate treatment strategies to maintain the quality of lakes and streams and keep them free of pathogens is important.

Several investigators found that enteric bacteria declined rapidly when transported through dispersed soils indicating that bacterial pollution occurs by transport via water through soil macropores (Spackman *et al.*, 2003). In studies where animal waste has been continually applied for several years, enteric bacteria are found in soils and groundwater (Entry *et al.*, 2000a, b, 2003). Pathogen survival time in the soil varies from 4 to 160 days (Abu-Ashour *et al.*, 1994) and first reflects the organism's ability to respond to non-parasitic and adverse environmental conditions. Obligate parasites usually only live a few minutes outside the host, but many pathogenic organisms can live in groundwater and soil for months (Entry *et al.*, 2000a, b). Several factors influence the survival of pathogens in soil after waste materials are applied. Soil moisture and temperature seem to be the most important of these factors. Survival of bacterial pathogens in soil increases when the soil is moist and temperatures are warm (Entry *et al.*, 2000a, b). Although further research is required, when waste is continually applied to forage production systems at least a 60-day period between waste applications and crop planting is advisable to let enteric bacteria die. After land application of animal waste, the opportunity for transfer of these organisms from soils to surface and groundwater and ultimately to humans depends in part on their ability to survive in the soil environment.

$\text{Al}_2(\text{SO}_4)_3$ in combination with polyacrylamide (PAM) tends to reduce total and fecal coliform numbers in animal wastewater. Entry and Sojka (2000) found that PAM + $\text{Al}_2(\text{SO}_4)_3$ mixtures reduced populations of total and fecal coliform bacteria in cattle, fish and swine wastewater leachate and surface runoff by approximately 100- to 1000-fold compared to no treatment. Entry *et al.* (2003) found that PAM + $\text{Al}_2(\text{SO}_4)_3$ reduced populations of total coliform and fecal coliform bacteria in swine manure

leachate from columns containing four different soil types ranging from sand to clay by at least tenfold compared to soil columns with PAM.

Entry *et al.* (2005) determined the influence of dairy manure and dairy compost with and without alum $\text{Al}_2(\text{SO}_4)_3$ on the survival of *E. coli* and *Enterococcus* spp. in the top 10 cm of soil. The influence of dairy manure and dairy compost with and without alum on the survival of *E. coli* and *Enterococcus* spp. on the surface of potato in relation to survival of these pathogens in soil was determined as well. They did not detect *E. coli* in any soil sample after the first sampling day. Seven, 14, 28, 179 and 297 days after solid dairy waste and compost and alum were applied to soil, alum did not consistently affect *Enterococcus* spp. and fecal coliform bacteria in the soil. *E. coli* was not detected in any soil, fresh potato skin or potato wash-water at 214 days after dairy manure or compost application regardless of alum treatment. Dairy compost or solid dairy manure application to soil at rates to meet crop phosphorus uptake did not consistently increase *Enterococcus* spp. and fecal coliform numbers in bulk soil. Solid dairy manure application to soil, to meet crop phosphorus uptake, increased *Enterococcus* spp. and fecal coliform numbers in potato rhizosphere soil.

However, fresh potato skins had higher *Enterococcus* spp. and fecal coliform numbers when solid dairy manure was added to soil compared to compost, N and P inorganic fertilizer and N fertilizer treatments, maybe due to increased sugar and nutrient content commonly seen in rhizosphere soils. Finally, *E. coli*, *Enterococcus* or total coliform bacteria were not detected on the exterior of the tuber, within the peel or within a whole baked potato after microwave cooking for 5 min.

Several studies have found high fecal coliform and *Enterococcus* spp. on fruits and vegetables. Gagliardi *et al.* (2003) found high fecal coliform and *Enterococcus* spp. numbers in irrigated soils and on cantaloupe that were irrigated with Rio Grande River water. *E. coli* O157:H7 has been found on a variety of salad vegetables (Islam *et al.*, 2004), inside radish (Hara-Kudo *et al.*, 1997) and on lettuce leaves (Seto and Frank, 1999).

Comparison of waste treatment methods

The comparative presentation of various vegetable waste treatment methodologies showed that though bioremediation stands for the most environmentally friendly technique, its required longer treatment time in conjunction with its weakness to deal with elemental contaminants makes imperative the employment of a second alternative technique which could either be a membrane process (low energy cost, reliability, reduced capital cost) or a coagulation/flocculation method because of its low cost and high effectiveness. Biogas production appears to be another promising and energy effective waste treatment method. On the other hand, methods like distillation and ozonation (high cost) and electrolysis (experimental level) are unlikely to dominate this field unless their high cost is substantially reduced in the near future. Table 11.1 provides a synoptical presentation of the most important vegetable waste treatment methods (parameters, quality control and results). Table 11.2 summarizes the advantages and disadvantages of the abovementioned vegetable waste treatment methodologies.

Table 11.1 Treatment methodologies, parameters, quality control methods and results of vegetable wastewaters

No	Kind of waste	Treatment	Parameters	Methodology	Quality control methods	Results	References
1	Almond shell waste (woody endocarp of the almond fruits)		Three commercially produced random samples of two different textures were evaluated as growing medium for soil-less production	Three random samples of two different textures were collected from transformed almond shell waste	Physical properties were measured: 1 Coarseness index, expressed as weight percentage of particles with >1 mm 2 Shrinkage, estimated as volume lost by the medium after drying at 105°C was determined 3 The wettability after drying was evaluated 4 Saturation extract method 5 Total organic matter content determined by loss on ignition for 4 h at 550°C	1 Acceptable growing medium as rockwool substitute for soil-less vegetable production 2 The coarseness index was around 85%, a figure much higher than for peat (63%) or coconut waste (35%) 3 Bulk density for both textures similarly showed very high values 4 Total pore space values were lower than for rockwool and the optimum levels 5 Air capacity was higher than 35% and very similar to rockwool	Urrestarazu <i>et al.</i> , 2005
2	Municipal solid wastes and fats of animal and vegetable origin	Anaerobic co-digestion	Synthetic OFMSW, which consisted of diluted dry pet food and two kinds of residual fats were used as co-substrates. Residual fats were: animal fat (lard), and commercial coconut oil	A semi-continuous, completely mixed liquid reactor was used for anaerobic digestion of wastes. After seven HRT under stable conditions, the co-digestion process started using animal fat. Animal fat increased up to 28% of the organic loading. Animal fat was then substituted by vegetable fat (coconut oil) maintaining the organic loading. Fats mixed with	1 Biochemical methane potential (BMP) was assayed to determine the potential toxicity of fats in the co-digestion process 2 Lipolytic activity was determined using a commercial kit 3 Water content, total solids (TS), total volatile solids, pH and alkalinity 4 Total lipid content 5 Methane and CO ₂ content	1 Anaerobic co-digestion of OFMSW and fat wastes is a suitable technology for energy production 2 Biogas production, biogas and methane yields are presented for each period of animal fat with increasing concentration 3 The low increase in methane content did not rise significantly with methane yield 4 High percentages of TVS removal (73%)	Fernández <i>et al.</i> , 2005

(Continued)

Table 11.1 (Continued)

No	Kind of waste	Treatment	Parameters	Methodology	Quality control methods	Results	References
				simulated OFMSW in feed influent tank. Reactor was continuously operated for at least two HRT to ensure steady state. Calcium bicarbonate was added occasionally to maintain the alkalinity level			
3	Waste cooking oil (canola)	Biodiesel production		<ol style="list-style-type: none"> 1 Complete process simulations were first carried out 2 HYSYS™ component library was used 	<ol style="list-style-type: none"> 1 Methanol and glycerol, both the non-random two liquid (NRTL) and universal quasi-chemical (UNIQUAC) thermodynamic/activity models were recommended to predict the activity coefficients of components in a liquid phase 2 Determination of plant capacity based on reported availability of waste cooking oil in the USA 3 Multistage distillation was used for methanol recovery as well as purification of both the FAME and glycerol products 	<ol style="list-style-type: none"> 1 Alkali-catalyzed process using virgin vegetable oil as raw material required the fewest and smallest process equipment units but at a higher raw material cost than other processes 2 Use of waste cooking oil to produce biodiesel reduced the raw material cost 3 Acid-catalyzed process using waste cooking oil was technically less complicated than the alkali-catalyzed process using waste cooking oil 	Zhang <i>et al.</i> , 2003
4	Fruit and vegetable wastes (FVW) (potato peelings, salad)	Anaerobic digestion for material recovery and	These wastes contain 8–18% total solids (TS), with a total volatile solids (VS)	Anaerobic digestion of FVW studied under different operating conditions		The overall results of anaerobic digestion of FVW suggest that the two-stage system is a promising process to treat	Bouallagui <i>et al.</i> , 2005

	waste, green peas and carrots)	energy production	content of 86–92%	and bioreactors. Conversion of 70–95% of organic matter to methane. Volumetric organic loading rate (OLR) of 1–6.8 g versatile solids (VS)/l day		these wastes with high efficiency in term of degradation yield and biogas productivity	
5	Recycled waste cooking oil biodiesel	Use of biodiesel spraying to clean oiled sediments	Batch, microcosm and mesocosm experiments	Spraying of oiled sediments with biodiesel and subjection to simulated tides in microcosm and mesocosm experiments		<ol style="list-style-type: none"> 1 Pure vegetable oil biodiesels (rapeseed and soybean) were significantly more effective in the cleanup of oiled sands (up to 96%) than recycled waste cooking oil biodiesel (70%) 2 Microcosm experiments revealed that the highest ratio of biodiesel to crude oil had the highest effectiveness for cleaning fine sands, with ratios of 2:1 (biodiesel:crude oil) giving the best results. In the mesocosm experiments a ratio 1:1 of soybean biodiesel to crude oil removed 80% of the oil in cobbles and fine sands 	Pereira and Mudge, 2004
6	Waste vegetable oil (WVO)	Decanting and transesterification of WVO samples to produce the ethyl ester using HCl as acidic catalyst	The combustion efficiency, η_c , and exhaust temperature, T_{exh} , as well as the common pollutants and emissions were tested over a wide range of air/fuel ratio ranging from very lean to very rich (10:1–20:1)	Comparison of the combustion and emissions of the biodiesel fuel to the standard (reference) petroleum-derived diesel fuel. Testing of both fuels (burning) at different air-to-fuel ratios ranging from about 10:1 to about 22:1 and at two levels of energy input rate	Fuel properties such as specific gravity, color, cloud point, flash point, refractive index, etc. Water coolant and exhaust temperatures, mass flow rates of air and fuel (to calculate the air-to-fuel ratio) and exhaust emissions including CO, CO ₂ , N and SO ₂ were also measured	<ol style="list-style-type: none"> 1 At the lower energy rate used, biodiesel burned more efficiently with higher combustion efficiency and exhaust temperature of, respectively, 66% and 600°C compared to 56% and 560°C for the diesel fuel 2 Biodiesel emitted less pollutants at both energy levels over the whole range of A/F ratio considered 	Tashtoush <i>et al.</i> , 2003

(Continued)

Table 11.1 (Continued)

No	Kind of waste	Treatment	Parameters	Methodology	Quality control methods	Results	References
7	Waste materials burnt were olive oil waste, municipal solid waste (MSW) and potato, which is representative of vegetable waste	Combustion of three high moisture content waste materials in a fluidized bed combustor was investigated and a comparison with co-firing of these materials with coal in the same combustor was made	Measurements of CO, NO _x , SO ₂ temperatures were made and the carbon combustion efficiency evaluated	Fluidized bed unit operating at a temperature of 900°C	Moisture content, SO ₂ , NO, N ₂ O	<ol style="list-style-type: none"> 1 The moisture content had an effect on combustion characteristics. Increasing the moisture content increased the amount of MSW burnt in the bed 2 Firing with coal resulted in markedly higher combustion efficiencies with an increase of approximately 10–80% when burning the simulated MSW. It was much lower than the value obtained, when co-firing potato and olive oil waste with coal 3 The high ash content of the simulated MSW 26%, compared with 5% in the other two waste materials resulted in slower burning and consequently the char particles were elutriated from the bed without being fully burnt 4 Emissions of NO and N₂O increase slightly with MSW fraction 	Suksankraisorom <i>et al.</i> , 2003
8	Vegetable oil refining industry wastewater (VORW)	Coagulation experiments using alum and ferric chloride	Chemical oxygen demand (COD) and oil and grease (OandG) loads	The study was conducted in three principal stages: waste characterization, lab-scale treatability studies and full-scale applications	The effluents were characterized in terms of pH, total COD, soluble COD (COD _s), biochemical oxygen demand (BOD ₅), Oand G, total suspended solids (TSS), total Kjeldahl nitrogen (TKN) and total phosphorus (TP). After analyzing various raw effluent parameters, lab-scale chemical	<ol style="list-style-type: none"> 1 VORW contained both high organic and N loads 2 Chemical treatability studies were conducted using Al₂(SO₄)₃·18H₂O and FeCl₃·6H₂O. The results showed 88 and 84% influent COD reduction, while OandG removal was 81 and 93%, respectively. The removal of total suspended solids (TSS) varied from 78 to 86% 	Azbar and Yonar, 2004

9	Fruit and vegetable wastes (FVW)	Anaerobic digestion	Volatile solids (VS) reduction, total methane production and methane yield	A continuously stirred tank reactor was used as a mesophilic (35°C) anaerobic reactor to examine the effect of adding the FVW and chicken manure (CM) to a system digesting cattle slurry (CS)	treatability studies were conducted using $\text{Al}_2(\text{SO}_4)_3 \cdot 18\text{H}_2\text{O}$ and $\text{FeCl}_3 \cdot 6\text{H}_2\text{O}$ Total and volatile solids and pH were measured. Ammoniacal nitrogen, alkalinity, methane and carbon dioxide concentrations were also measured	High concentrations of volatile fatty acids were produced when FVW was co-digested with cattle slurry with the feed containing 30% or more FVW. Mixtures of CS and FVW, with proportions of FVW of up to 50% in feed, gave a good co-digestation in terms of methane yield, but the VS did decrease slightly	Callaghan <i>et al.</i> , 2002
10	FVW	Anaerobic digestion	Biogas production, total solids, total volatile solids and pH, total organic carbon (TOC), total nitrogen	Tubular anaerobic digesters on a laboratory scale using psychrophilic, mesophilic and thermophilic processes	Biogas production, total solids, total volatile solids and pH, total organic carbon (TOC), total nitrogen	The resulting higher degradation efficiency in thermophilic conditions has been associated with the higher specific biogas production and with the improvement of the energy balance of the process	Bouallagui <i>et al.</i> , 2004
11	Horse manure and bedding, mink farm wastes, municipal solid waste (MSW) and sewage sludge from a chemothermomechanical pulp mill	Composting	Chemical composition, pH, electrical conductivity and respiration rate	Germination and seedling emergence of tomatoes, cress (<i>Lepidium sativum</i> L.) or radish (<i>Raphanus sativus</i> L.) were tested to assess phytotoxicity of the four amendments	Chemical composition, pH, electrical conductivity and respiration rate. Assay for phytotoxic potential using seed germination and seedling emergence tests. The methods used were modifications of established toxicity tests used in the assessment of composts and contaminated soil	1 Stimulation of root and shoot growth of tomato seedlings by mink farm compost and horse manure compost. MSW compost and pulp mill solids were strongly inhibitory 2 Both toxic constituents and nutrient imbalances may be responsible for the growth-inhibiting effects of these amendments	Levy and Taylor, 2003
12	Hazelnut soapstock/waste sunflower oil mixture	Biodiesel production	Methanol, sulfuric acid and sodium hydroxide	A methyl ester biodiesel was produced from a hazelnut soapstock/waste sunflower oil	CO , CO_2 , NO_2 , SO_2	1 Hazelnut soapstock/waste sunflower oil methyl ester can be partially substituted for the diesel fuel at most operating conditions in terms of the performance	Usta <i>et al.</i> , 2005

(Continued)

Table 11.1 (Continued)

No	Kind of waste	Treatment	Parameters	Methodology	Quality control methods	Results	References
				mixture using methanol, sulfuric acid and sodium hydroxide in a two-stage process		<p>parameters and emissions without any engine modification and preheating of the blends</p> <p>2 Although the heating value of the biodiesel is lower than that of the diesel fuel, biodiesel blends produced a slightly higher torque and power at both full load and partial loads</p> <p>3 The exhaust temperatures of the blend at full load were higher than those of diesel, while the differences were fairly small at partial loads</p>	
13	Solid dairy waste	Composting, alum treatment	<i>E. coli</i> , fecal coliforms, Enterococcus, total coliforms	Addition of dairy compost or solid dairy manure at rates to meet crop phosphorus uptake	<i>E. coli</i> , fecal coliforms, <i>Enterococcus</i> spp., total coliforms	Solid dairy manure or dairy compost did not consistently increase <i>E. coli</i> , <i>Enterococcus</i> or fecal coliform bacteria numbers compared to soil receiving inorganic N fertilizer or inorganic N-P fertilizer treatments after 2-7 days	Entry <i>et al.</i> , 2005
14	WVO (Palm oil)	Transesterification under various conditions. H ₂ SO ₄ and different concentrations of HCl and ethanol at different excess levels were used	H ₂ SO ₄ and HCl	It was most efficient to fix reaction temperature at the mixture's boiling point (90°C), and use only commercial (96%) ethanol since it can be produced from agricultural renewable sources. Stirring was not needed. The experimental plan involved four levels of HCl catalyst	The specific gravity, γ , of the end product as it varied with reaction time was chosen to serve as an indicator for the effectiveness and completeness of the conversion process. Viscosity measurements	<p>1 Higher catalyst concentrations (1.5-2.25 M) produced biodiesel with lower specific gravity, γ, in a much shorter reaction time than lower concentrations</p> <p>2 The H₂SO₄ performed better than HCl at 2.25 M, as it resulted in lower γ</p>	Al-Widyan and Al-Shyoukh, 2002

15	Artichoke waste		Retention time	concentration and three levels of excess alcohol						Sanchez-Rabaneda <i>et al.</i> , 2003
				The plant extract was obtained by extraction of wastes from fresh-handling and industrial canning processing of artichoke hearts with ethanol-water (50:50)	Liquid chromatography coupled to ionspray mass spectrometry in tandem mode with negative ion detection				The combination of full scan mode with different MS-MS approaches has been a powerful tool to selectively screen artichoke by-product extracts for the occurrence of phenolics and structurally related substances. The major compounds were found to be both caffeoylquinic and dicaffeoylquinic acids, luteolin glucuronide, luteolin galactoside, quercetin, and some quercetin glycosides	
16	Potato waste, pig manure, slaughterhouse waste, vegetable waste and various kinds of industrial waste	Anaerobic co-digestion	Partial alkalinity (PA), total alkalinity (TA), VFA concentrations, pH, total solids, volatile solids, total N, total C, phosphorus, C/N ratio	1 Full-scale anaerobic digester co-digesting sludge from wastewater treatment with starch-rich waste from a potato processing facility 2 Full-scale co-digestion plant. The full-scale anaerobic digester was intended to treat around 45 000 tonnes of organic waste per year	Partial alkalinity (PA), total alkalinity (TA), VFA concentrations, pH, total solids, volatile solids, total N, total C, Phosphorus, C/N ratio				1 The co-digestion of potato waste resulted in a low buffered system and when the fraction of starch-rich waste was increased, the result was a more sensitive process, with process overload occurring at a lower organic loading rate (OLR) 2 In the low buffered system pH, PA and VFA measurements were useful for process monitoring, whereas in the highly buffered system only VFA measurements indicated imbalance in the degradation process	Murto <i>et al.</i> , 2004
17	Vegetable oils contained in waste activated bleaching earth (soybean, palm and rapeseed oil)	Vegetable oils from waste bleaching earth samples were organic-solvent extracted	Saponification value and unsaponifiable matter content were determined, viscosity of refined oils, extracted oils and products from methanolysis	Methanolysis was efficiently catalyzed by <i>Rhizopus oryzae</i> lipase in the presence of high water content and by a single addition of methanol. <i>R. oryzae</i> lipase was not	Determination of saponification value and unsaponifiable matter content, viscosity of refined oils, extracted oils and products from methanolysis. Fatty acid composition was determined by GC				The highest conversion yield reached 55% (w/w) with palm oil after 96 h of reaction. Adverse viscosity conditions might have influenced methanolysis of extracted soybean and rapeseed oil in spite of high water or methanol concentrations	Lara Pizarro and Park, 2003

(Continued)

Table 11.1 (Continued)

No	Kind of waste	Treatment	Parameters	Methodology	Quality control methods	Results	References
18	Green-waste compost	N mineralization from high N vegetable crop residues by the addition of organic materials	Mineral N	Evolution of mineral N was monitored by destructive sampling. After 15 weeks, molasses was added to part of the samples in each treatment, and incubation continued for another 12 weeks	inactivated by methanol in concentrations lower than 4 milli-equivalents and 75% water content of the methylated fatty acids. Lipase activity was measured with a Lipase Kit S (Dainippon Pharmaceutical Co. Ltd, Osaka) Mineral N, C:N ratio, polyphenols	All materials added during the first incubation stage, except the low C:N compost, resulted in significant immobilization of the residue N. In the straw treatment, remineralization started in the first stage of incubation from day 50 onwards. The addition of molasses caused a strong and significant remineralization in the second stage (equivalent to 73% of the N initially immobilized) in the treatment with the high C:N ratio compost. In the case of tannic acid, there was no consistent effect on mineralization from addition of molasses	De Neve <i>et al.</i> , 2004
19	FVW	Anaerobic digestion for conversion into biogas.	Examination of the effect of hydraulic retention time (HRT) and the feed concentration on the extent of the degradation of the waste	A semi-continuously mixed mesophilic tubular anaerobic digester was employed	HRT, feed concentration total solids (TS), total volatile solids (TVS) and pH, biogas yield, methane content	<ol style="list-style-type: none"> 1 In a tubular digester FVW could be treated anaerobically with a high stability, a high depuration rate and energy recovery with a good process economy 2 The overall performance of the reactor was depressed by changing the feed concentration from 8% to 10% TS (dry weight) 	Bouallagui <i>et al.</i> , 2003

20	FWW		Methane yields (B_0) and methane production rate constants (k)	Mixture of vegetable wastes served as feed for the continuously stirred tanks reactor (CSTR)	Biochemical methane potential, methane yields (B_0) and methane production rate constants (k), TS, VS, VFA and pH	<ol style="list-style-type: none"> 1 The ultimate methane yields (B_0) and kinetics of fruit wastes ranged from 0.18 to 0.732 l/g VS added and 0.016 to 0.122/day, respectively, and that of vegetable wastes ranged from 0.19 to 0.4 l/g VS added and 0.053 to 0.125/day, respectively 2 Temperature had no effect on the B_0 of mango peels 3 Onion peels exhibited yields significantly ($P < 0.05$) similar to cellulose, while majority of the vegetable wastes exhibited yields greater than 0.3 l/g VS 	Gunaseelan, 2004
21	Natural organic food wastes	Degradation process	Gas productivity and mass of solid residual	Special unit was created where the degradation process is activated by enforced reinvention of portions of elaborated biogas into digester	Gas productivity and mass of solid residual <i>Lactobacillus</i> spp., <i>Clostridia</i> spp., aerobic conventional pathogens (<i>Enterobacteriaceae</i> spp., <i>Proteus</i> spp., staphylococci)	<ol style="list-style-type: none"> 1 Evaluation of the effectiveness of proposed technology and determination of leading role of lactobacilli and clostridia in process of natural wastes biodegradation 2 (i) gradual quantitative increase of <i>Lactobacillus</i> spp. (from 10^3 to 10^5 colony forming units (CFU) per ml), (ii) activation of <i>Clostridium</i> spp. (from 10^2 to 10^4 CFU/ml) and (iii) elimination of aerobic conventional pathogens 	Ilyin <i>et al.</i> , 2004
22	Composted cotton-gin trash, composted yard waste, or cattle manure	Two treatments, including either an alternative organic soil amendment (composted	Production history and time	Field experiments were conducted in 1996 and 1997 at three farms with a history of either conventional or	Numbers of culturable bacteria, fluorescent pseudomonad bacteria, enteric bacteria, total fungi, thermophilic microorganisms,	<ol style="list-style-type: none"> 1 Increase of calcium, potassium, magnesium and manganese in soils in this study that received organic amendments, but not in 	Bulluck <i>et al.</i> , 2002

(Continued)

Table 11.1 (Continued)

No	Kind of waste	Treatment	Parameters	Methodology	Quality control methods	Results	References
		cotton-gin trash, composted yard waste, or cattle manure) or synthetic soil amendment (fertilizer) were applied to three replicate plots at each grower field location		organic production	<i>Trichoderma</i> , <i>Fusarium</i> , <i>Phytophthora</i> and <i>Pythium</i> species were quantified	those soils receiving synthetic fertilizers 2 Alternative soil amendments can enhance soil biological, chemical, and physical attributes of soil compared with synthetic fertilizers and improve plant yield 3 Detection of propagule densities of <i>Trichoderma</i> species, thermophilic micro organisms and enteric bacteria in greater numbers in soils amended with alternative than synthetic amendments	
23	Rapeseed oil in waste activated bleaching earth (ABE)	Oil oxidation	Extent of oxidation of rapeseed oil	Waste ABE with 40% (w/w) rapeseed oil was stored for 80 days. Rapeseed oil was extracted from waste ABE by double extraction with <i>n</i> -hexane	Peroxide value, acid value, concentrations of organic acids, acetaldehyde and unsaturated fatty acid and content of polymerized triglycerides, saponification value	Peroxide value, acid value and concentrations of organic acids and acetaldehyde did not affect riboflavin production. However, the content of polymerized triglycerides markedly increased the viscosity of rapeseed oil and caused an exponential decrease in riboflavin production	Park and Ming, 2004
24	Food waste (coffee grounds)	Removal of lead ions in drinking water by coffee grounds as vegetable biomass	Measurement of fat and protein content, adsorption isotherms for lead ions, and adsorption rates for lead ions for coffee beans and grounds	Adsorption isotherms of lead ions measured at 297 K with coffee grounds, activated carbon and activated alumina. They were used to select adsorbents suitable for the removal of lead ions	Concentration of lead ions, fat and protein content, rate adsorption of lead ions on coffee grounds	1 The rate of lead ion adsorption by coffee grounds was directly proportional to amount of coffee grounds added to the solution. When coffee grounds were degreased or boiled, the number of lead ions decreased 2 Proteins contained in coffee beans depend upon the adsorption of lead ion. Coffee grounds could be used to remove lead ions from drinking water	Tokimoto <i>et al.</i> , 2005
25	FWW	Anaerobic co-digestion	The daily gas production	Digestion of primary sludge (PS)	Total solids (TS), volatile solids (VS), pH and daily	1 Biogas production for co-digestion is much greater	Gómez <i>et al.</i> , 2006

			(expressed as l/day) together with the organic loading rate (OLR) (expressed as g VS fed/day)	and co-digestion of this sludge with the fruit and vegetable fraction of municipal solid wastes (FVFMSW) under mesophilic conditions. This mixture was prepared with a PS content of 22%. The anaerobic digestion process was evaluated under static conditions and with different mixing conditions	biogas production, biogas yield	thanks to the larger volatile-solid (VS) content of this feedstock 2 Biogas yield and specific gas production for the two digestion processes are similar, with values in the range 0.6–0.8 l/g VS destroyed for the first parameter and in the range 0.4–0.6 l/gVS fed for the second	
26	WVO (sunflower oil)	Frying oil	Viscosity, density, calorific value and flash point	The performance and exhaust emissions of a single cylinder diesel engine were evaluated using diesel, waste frying oil (without preheating) and waste frying oil preheated to two different inlet temperatures (75 and 135°C)	Viscosity, density, calorific value and flash point	1 Waste frying oil required a heating temperature of 135°C to bring down its viscosity to that of diesel at 30°C 2 The engine performance was improved and the CO and smoke emissions were reduced using preheated waste frying oil	Pugazh-vadivu and Jeyachandran, 2005
27	FWW	Transformation of the extracts from vegetable and fruit processing wastes into the yeast biomass enriched with selenium	Nitrogen, dissolved organic matter, biomass concentration	Water extracts of cabbage, watermelon, a mixture of residual biomass of green salads and tropical fruits were used for yeast cultivation	Enumeration of yeast and bacterial cells, cell growth measurements, total solids, volatile solids, selenium content, carbon and nitrogen content	1 The extracts from vegetable and fruit processing wastes can be used for production of yeast biomass without any nutrient supplements 2 Yeast biomass obtained by cultivation in such medium contained 150 µg Se/g of dry biomass	Stabnikova <i>et al.</i> , 2000

(Continued)

Table 11.1 (Continued)

No	Kind of waste	Treatment	Parameters	Methodology	Quality control methods	Results	References
28	Shrimp waste	Different vegetable oils (sunflower oil, groundnut oil, gingelly oil, mustard oil, soy oil, coconut oil and rice bran oil)	Extraction yield	Determination of the extraction yield of shrimp waste carotenoids in different vegetable oils	Carotenoid yield is calculated and presented as total carotenoid as astaxanthin. A regression equation was derived for carotenoid yield as a function of heating time, temperature of heating and oil level to waste	<ol style="list-style-type: none"> 1 Highest yield was obtained with extraction using refined sunflower oil compared to groundnut oil, gingelly oil, mustard oil, soy oil, coconut oil and rice bran oil. The extraction yield of carotenoids in sunflower oil was significantly influenced by level of oil to waste, time and temperature of heating waste with oil before centrifugation to separate pigmented oil 2 Determination of optimized conditions for extraction of shrimp waste carotenoids in sunflower oil 	Sachindra and Mahendrakar, 2005
29	WVO (olive and sunflower oil)	Thermal treatment at 150 and 225°C in the time interval of 1–15 days	T and time, unsaturation degree, viscosity		Structural changes in oils were monitored with FT-IR and ¹ H NMR measurement of the oil viscosities using a rotational Viscotester	<ol style="list-style-type: none"> 1 The density and viscosity of the original vegetable oils, heated at 150 and 250°C, tend to increase with time of treatment. The viscosity of the oils increased very quickly 2 Sunflower oil was found to be more sensitive to thermal treatment, undergoing greater changes in its properties, especially in viscosity, which may show a marked increase 	Valdés and García, 2006
30	FVW (apple, cherry and pear pomaces; blackcurrant and chokeberry pomaces, carrot)	Prior to physical and chemical determinations, materials were defrosted, dried and ground	Cellulose, hemicellulose, lignin and pectins	Determination of particular dietary fiber fractions in samples containing apple, blackcurrant, chokeberry, pear, cherry and carrot pomace	Analysis for contents of dry matter (AOAC), non-starch polysaccharides (NSP) and lignin. Enzymic hydrolysis of the starch, precipitation of NSP in ethanol and acid hydrolysis of the NSP. Fractions of pectins, hemicellulose, cellulose and lignin were obtained	<ol style="list-style-type: none"> 1 In each pomace sample, pectins occurred in the smallest amounts and the content of lignin was very high (blackcurrant and cherry pomace) or comparatively high (pear, chokeberry, apple and carrot pomace). The other dietary fiber components were difficult to form into clearly defined 	Nawirska and Kwasniowska, 2005

31	WVO (olive and sunflower oil)	Agglomeration of coal fines cleaning wastes (CFCW) from two different Spanish coal cleaning plants with waste vegetable oils (WVO) of household origin	Organic matter recovery (OMR) and ash rejection (AR)	A wide range of oil concentration was employed with the aim of recovering high-calorific value/low-ash content coal. In addition to the WVO concentration, the effects of desliming the CFCW and the agglomerates separation method were also studied	Density, viscosity and oil-water interfacial tension, which are known to affect oil agglomeration capability were measured	<p>groups. Their proportions varied from one pomace type to another. The highest contents of hemicellulose and pectins were in chokeberry pomace (41%) and the lowest in apple pomace (36%)</p> <ol style="list-style-type: none"> 1 Recovering of ready to burn coal fines by the agglomeration of coal cleaning fines wastes (CFCW) with waste vegetable oils (WVO) 2 The risk of spontaneous combustion of coal dumps and the amount of coal wastes to be handled and disposed of can be reduced 	Valdés and Garcia, 2006
32	Vegetable processing wastes	The ethanol extracts of leafy vegetables (LV) were added to refined sunflower and groundnut oils heated to frying temperature and stored for 4 weeks	Peroxide value, polyphenol content, antioxidative activity capitata), coriander	Four leafy vegetables viz. cabbage (<i>Brassica oleracea</i> var. <i>scavenging</i> activity, leaves (<i>Coriandrum sativum</i>), hongone (<i>Alternanthera sessilis</i>) and spinach (<i>Spinacia oleracea</i>) were analyzed for antioxidant activity with standard methods	Peroxide value, polyphenol content, free-radical estimation of anti-FeCl ₂ -H ₂ O ₂ -stimulated linoleic acid peroxidation, reducing power, hydroxyl radical scavenging activity, antioxidant activity of LVE in oils	<p>1 The polyphenol content ranged from 5 mg in cabbage to 69.5 mg in spinach and this was moderate. Reducing power of the leafy vegetables indicative of electron donating property for termination of free radical chain reactions followed the order: spinach < cabbage < coriander leaves < hongone leaves. LV exhibited good hydroxyl radical and DPPH scavenging activities. LV extracts conferred a protective effect on peroxide formation on storage of heated oils</p>	Shyamala <i>et al.</i> , 2005

(Continued)

Table 11.1 (Continued)

No	Kind of waste	Treatment	Parameters	Methodology	Quality control methods	Results	References
33	WVO rapeseed oil)	Lipase-catalyzed alcoholysis of waste plant oil with methanol in an organic solvent system	Methanol, FAME, lipase activity	Addition of activated bleaching earth (ABE) from the oil processing industry on the production of fatty acid alkyl esters (FAMEs)	Methanol, FAME, lipase activity	<p>2 LV are excellent antioxidants that are stable at high temperatures and can serve as substitutes for synthetic antioxidants</p> <p>Improvement of the FAME formation rate ninefold over the mixtures that did not contain ABE when ABE was added to a reaction mixture. The optimum ratio of ABE to rapeseed oil was 0.7 for the esterification of the rapeseed oil, where the lipase activity remained high without inactivation</p>	Park and Mori, 2005
34	Municipal solid waste	Home biodegradable waste digestion	Waste sustainability	Minimization of municipal solid waste and diversion from landfill are necessary for the UK to manage waste sustainably and achieve legislative compliance. A survey of householder attitudes and experiences of a trial for minimizing household food waste from waste collection in the county of West Sussex, UK is described. The minimization method used the Green Cone food digester, designed for garden installation	Postal questionnaire, weight survey	<p>1 Household waste minimization and diversion of biodegradable waste from landfill</p> <p>2 The waste material most frequently put in the digester was cooked food (91%), followed by fruit waste, vegetable matter and bones/meat. Some respondents were using it for garden and animal waste from pets</p>	Bench <i>et al.</i> , 2005

35	Vegetable wastes such as cauliflower leaves, cabbage leaves, pea pods and pea vines	Supplementation with minerals and common salt	The purine nitrogen index (PNI), which is an indicator of efficiency of microbial protein synthesis, digestibility of nutrients, protein fractionation	Each vegetable waste, supplemented with minerals and common salt, was fed ad lib as complete feed, to 3 bucks (Beetle × Anglo Nubian × French Alpine; 6 years old of 62.6 ± 1.1 kg BW)	Determination of DM, CP, total ash, cellulose and other cell wall constituents like NDF, ADF and ADL, hemicellulose by difference in NDF and ADF, protein assay, total sugars, reducing sugars and phenolics. Calculation of the non-reducing sugars by difference between total and reducing sugars. Fractionation into four protein fractions based on solubility; distilled water soluble (albumin), sodium chloride soluble (globulin), ethanol soluble (prolamin) and sodium hydroxide soluble (glutelins). The urine samples were analyzed for total-N, purine derivatives (PD), allantoin, uric acid and creatinine by the method of Folin and Wu. Purines absorbed were calculated from the daily urinary PD excreted. Purine nitrogen index (PNI) presents the ratio between purine-N and total-N in urine	The leaves of cauliflower and cabbage had low ($P < 0.05$) concentration of cell wall constituents, but high ($P < 0.05$) concentration of CP, except that CP of pea pods was comparable with cabbage leaves. Cabbage leaves had highest (20.6%) and pea pods had lowest (4.8%) concentration of water-soluble sugars. Cauliflower leaves had the highest concentration of phenolics (5.9%), comparable with cabbage leaves, but the lowest concentration was observed in pea pods (0.3%). The fractionation of proteins indicated that vegetable waste in general had high concentration of water-soluble (54–62%) and low concentration of alcohol soluble (8–9%) fractions. Digestibility of nutrients except that of NDF was comparable in cabbage and cauliflower leaves, but higher ($P < 0.05$) than other vegetable wastes and conventional green oats fodder	Wadhwa <i>et al.</i> , 2006
36	FVW	Dehydration	Nutritional and microbiological analyses	The effectiveness of different drying systems used for dehydration of certain fractions of biodegradable municipal solid wastes with a	Nutritional and microbiological analyses of waste samples were carried out before and after drying. The nutritional parameters determined were moisture, ash, fats, fiber,	Biodegradable municipal wastes collected from the produce sections (fruit and vegetables) of large supermarkets have a potential for recycling and for the use as fodder	Pinacho <i>et al.</i> , 2006

(Continued)

Table 11.1 (Continued)

No	Kind of waste	Treatment	Parameters	Methodology	Quality control methods	Results	References
				high moisture content (fruit and vegetable remains) was analyzed. For larger quantities of wastes, a discontinuous cabinet dryer and a continuous rotary dryer were used	protein and carbohydrates. Microbiological characterization of the waste was performed, analyzing total aerobic mesophiles, <i>Enterobacteria</i> , molds and yeasts, <i>Salmonella</i> , <i>Escherichia coli</i> and <i>Staphylococcus aureus</i>		
37	VW	Biodegradation	Biogas production, methane production	The artificial inoculum consisted of active sludge adapted to wastes mixed with excreta of insects which consume plant wastes	Biogas production, methane production	Using this inoculum the biodegradation process takes less time than using active sludge. Regulation of methane concentration from traces to 90% may be achieved by adding methane reactor to the plant digester	Ilyin <i>et al.</i> , 2005
38	VWO	Transesterification	Methyl esters	Transesterification of four vegetable oils – canola oil, greenseed canola oil from heat-damaged seeds, processed waste fryer grease and unprocessed waste fryer grease – was carried out using methanol and KOH as catalyst	The methyl esters of corresponding oils were separated from the crude glycerol, purified and characterized by various methods to evaluate their densities, viscosities, iodine values, acid numbers, cloud points, pour points and gross heat of combustion, fatty acid and lipid compositions, lubricity properties, and thermal properties, potassium level	<ol style="list-style-type: none"> 80–85% of the ester was from unsaturated acids Substantial decrease in density and viscosity of the methyl esters compared to their corresponding oils suggested that the oils were in their mono- or diglyceride form The canola methyl ester enhanced the fuel's lubricity number The ester with most potential for being an additive or a substitute for diesel fuel is the canola methyl ester, whose physical and chemical characteristics are similar to diesel fuel 	Dmytryshyn <i>et al.</i> , 2004
39	Vegetable, fruit and garden wastes (VFG)	Composting	Silage maize N uptake and N concentration	The effects of the application of this VFG compost on	Soil organic matter, total nitrogen concentration, silage	<ol style="list-style-type: none"> Economical optimum dry matter yields with substantial saving of mineral 	Nevens and Reheul, 2003

				silage maize on a sandy loam soil was studied. A yearly application of 22.5 Mg of VFG compost/ha, in addition to 42 Mg of cattle slurry/ha resulted in economical optimum dry matter yields with substantial saving of mineral fertilizer N	maize dry matter yield, soil pH, available K and Ca concentrations, available P	fertilizer N 2 Silage maize N uptake and N concentration in maize were higher when compost was applied. Despite the low N output/input rate with compost application, it did not result in high residual soil nitrate N, provided that the additional mineral fertilizer N was adapted to the economic optimum level	
40	Solid, mainly agricultural organic wastes	Composting	EC value, organic matter concentration	Materials such as olive press cake, olive tree leaves (OTL) and branches, vine branches (VB), pressed grape skins (PGS), pig manure (PM), sewage sludge and the organic fraction of municipal solid waste (OFMSW) have been evaluated for their behavior during composting, their compatibility in mixtures and the quality of the end product	Detailed physicochemical (pH, electrical conductivity (EC), nutrients concentration, heavy metal concentration, etc.) and biological analyses (pathogenic microorganisms). Agronomic evaluation, in which composts were used either as a soil amendment or as a component for substrates in open air or covered (greenhouse) cultivation mainly of local vegetables (tomatoes, cucumbers, etc.). Volatile solids (VS) by the ignition at 600°C for 4 h, organic carbon, total nitrogen, by the micro-Kjeldahl method, NH ₄ -N and NO ₃ -N, by the magnesium oxide-Devarda alloy method, the bulk density, particle density, total pore space and water	1 Successful composting of all materials especially when mixed. The end products contained large amounts of organic matter, usually combined with an increased EC value 2 Pressed grape skins should be considered as the ideal raw material, producing a high quality compost, with the lowest EC value (1.57 mS/cm) and the largest organic matter concentration (84.50%), compared to all other materials	Manios, 2004

(Continued)

Table 11.1 (Continued)

No	Kind of waste	Treatment	Parameters	Methodology	Quality control methods	Results	References
41	Municipal solid waste (MSW)	Composting under aerobic conditions	Potato shoot N, total dry matter (TDM) and total fresh tuber yield (TTY) and sweet corn shoot N, total dry matter (TDM) and total marketable ear yield (TMY)	The effect of municipal solid waste (MSW) compost on soil P availability and uptake by potato (<i>Solanum tuberosum</i>) and sweet corn (<i>Zea mays</i>) crops grown was evaluated. Three rates of compost (MSW1, MSW2 and MSW3), one rate of chemical fertilizer (NPK) and one mixture of 1/2 MSW compost and 1/2 NPK fertilizer (MIXTURE) were used on both crops according to soil P test results	capacity, mineral elements: potassium was determined by flame emission spectrophotometry, while Ca, Mg, P and heavy metal concentrations were determined with an atomic absorption spectrophotometer P, K, Ca, Mg, Zn, C, Al, Fe, C:N ratio, pH, TDM, N	1 Inorganic fertilizer (NPK) and a mixture of MSW compost and inorganic fertilizer produces higher yields than MSW compost alone. Nonetheless, MSW compost supplies similar amounts of P as inorganic fertilizer (NPK) 2 MSW compost increased soil pH compared to inorganic fertilizer. The application of both inorganic fertilizer and MSW compost decreased P adsorption by the soil by up to 30% 3 Municipal solid waste compost may be a good source of P for both potatoes and sweet corn	Mkhabela and Warman, 2005
42	VO	Recycling and reuse of these wastes in the process after preliminary treatment.	pH, COD, total dissolved solid (TDS) concentration, dissolved oxygen, sulfide, sulfate, phosphate, heavy	An industry manufacturing refined vegetable oil and hydrogenated vegetable oil	pH, COD, total dissolved solid (TDS) concentration, dissolved oxygen, sulfide, sulfate, phosphate, heavy metals, T, color	1 The waste from vegetable oil refinery included solid wastes viz. spent earth, spent catalyst, chemical and biological sludge and wastewater from soap	Pandey <i>et al.</i> , 2003

		Physicochemical processes including air flotation, skimming of oil, flocculation, coagulation for colloidal pollutants followed by biological processes for dissolved organics followed by biological processes are adopted for treatment of such wastewater	metals, T, color	(vanaspati) with a capacity of 58.5 tonnes/day generated wastewaters and solid wastes (viz. spent earth, spent catalyst, chemical and biological sludges). The wastewater streams were mainly from vat house after soap splitting, floor washing, cooling tower, boiler and filter press		<ol style="list-style-type: none"> splitting unit, floor washing, cooling and boiler sections The combined wastewater from soap splitting and floor washing had high concentration of oil and COD The remaining wastewater could be treated in the existing effluent treatment plant (ETP) and the treated effluent met the prescribed limits of discharge into inland surface water 	
43	FWW	Two-phase anaerobic digestion	VFA, COD	Two coupled anaerobic sequencing batch reactors (ASBR) operated at mesophilic temperature were employed. The effect of increasing loading rates on the acidification step was investigated	Volatile fatty acids (VFA), COD, total solids (TS), total volatile solids (TVS), total suspended solids (TSS), pH, total nitrogen Kjeldahl (TNK)	<ol style="list-style-type: none"> FWW is highly biodegradable with a conventional two-phase reactor and 96% of the total COD was converted to biomass and biogas The hydrolysis yield (81%) stabilized at an OLR of 7.5 g COD/l/day) The volatile fatty acids concentration increased when the loading rate increased and reached its maximum value (13.3 g/l) at higher loading rate tested (10.1 g COD/l/day) Methanogenic fermentation of the liquefaction acidification products was efficiently performed in the ASBR reactor and high methane productivity was obtained 	Bouallagui <i>et al.</i> , 2004

Table 11.2 The advantages and disadvantages of vegetable waste treatment methodologies

No	Treatment	Advantages	Disadvantages	References
1	Anaerobic digestion	<p>The advantages for thermophilic digestion include:</p> <ol style="list-style-type: none"> 1 increased reaction rates in relation to the destruction of organic matter 2 production of lower amount and better quality of digested effluent 3 the improvement of the energy balance of the technology and therefore less capital cost as a result of smaller digester size 4 Continuous two-phase systems appear as more highly efficient technologies for anaerobic digestion of FVW due to the buffering of the organic loading rate (first stage), allowing a more constant feeding rate of the methanogenic second stage 5 Anaerobic treatment of FVW with a high stability, a high depuration rate and energy recovery with a good process economy 6 Two-phase separation with conventional ASBR reactors resulted in high process stability, significant biogas productivity and better effluent quality from fruit and vegetable wastes anaerobic digestion 	<ol style="list-style-type: none"> 1 Rapid acidification of fruit and vegetable wastes decreasing the pH in the reactor 2 Larger volatile fatty acids production (VFA), which stress and inhibit the activity of methanogenic bacteria 3 Depression of the overall performance of the reactor by increasing the feed concentration 	Bouallagui <i>et al.</i> , 2003, 2004, 2005
2	Combustion	Firing with coal resulted in markedly higher combustion efficiencies		Suksankraisorn <i>et al.</i> , 2003
3	Composting	Application of pulp mill solids to agricultural soil without composting may lead to deleterious effects on vegetable crops	<ol style="list-style-type: none"> 1 Inhibition of seedling emergence and pulp mill solids production by MSW compost and unamended potting soil 2 Deformation in radish and cress seedlings 	Levy and Taylor, 2003
4	Transesterification	<ol style="list-style-type: none"> 1 Conversion of waste palm oil by transesterification to produce ethyl esters gives a product comparable to applying the process to neat VO's with properties comparable to those of the local diesel fuel 2 Emission of less pollutants by biodiesel production 	Deterioration of biodiesel combustion performance at the higher energy input due to its high viscosity, density and low volatility	Al-Widyan and Al-Shyoukh, 2002, Tashtoush <i>et al.</i> , 2003

5	Co-digestion	Co-digestion of potato waste resulted in a low buffered system	Formation of a highly buffered system as the manure contributed to high amounts of ammonia. However, ammonia might be toxic to the microorganisms	Murto <i>et al.</i> , 2004
6	Degradation	This technology allows to save energy normally used for electromechanical agitation and to create optimal environment for anaerobic bacteria growth		Ilyin <i>et al.</i> , 2004
7	Dehydration	<ol style="list-style-type: none"> 1 Continuous rotary dryer was the most efficient type of equipment studied, since it allowed a dried waste to be obtained with better nutritional and microbiological qualities and in accordance to the specifications of the products for animal feeding 2 The discontinuous cabinet dryers also offer ease of handling, control and maintenance, but it is necessary to cut the waste into small pieces before the waste is introduced into the dryer. These dryers require a greater drying time with the consequent increase in operating cost 	<p>The drying systems using natural and forced convection offer:</p> <ol style="list-style-type: none"> 1 ease of handling, maintenance and cleaning but do not result in a good dehydration of the wastes 2 they show some problems such as manual pretreatment of the samples 3 condensation on the surface of the walls and on the door of the oven 4 unpleasant odor 5 non-homogeneity of the temperature inside the oven 6 fermentation or combustion of the samples due to the low or high temperature, respectively 	Pinacho <i>et al.</i> , 2006
8	Biodegradation	Volumes of solid non-edible plants residuals could be turned into liquid phase within a short period of time using special microbial associations, preadapted to certain substrates. From these liquid phases methanogenesis is performed much faster than from their solid analogues. Methane as an energetic carrier can be applicable in certain closed ecological habitats		Ilyin <i>et al.</i> , 2005

Conclusions

Waste management in vegetable production is a tough problem and its optimum solution must foresee local factors to be taken into account. Among them are the type of vegetable extraction process in use, the possibility of handling and storing the wastes, the volume of the wastes and land availability.

Waste treatment methods were divided in two categories: the currently employed and the novel ones. Although novel methods (bioremediation, biogas production, distillation, ozonation and electrolysis) appear to be promising and attractive alternatives, handicaps like high cost, requirements for trained personnel and high capital investment are still holding them back from widespread application in the vegetable waste industry.

References

- Abad, M., Noguera, P., Puchades, R., Maqueira, A. and Noguera, V. (2002). Physico-chemical and chemical properties of some coconut coir dusts for use as a peat substitute for containerised ornamental plants. *Bioresource Technol* **82**, 241–245.
- Abigor, R.D., Uadia, P.O., Foglia, T.A., Haas, K.C., Okpefa, J.E. and Obibuzor, J.U. (2000). Lipase-catalyzed production of biodiesel fuel from some Nigerian lauric oils. *Biochem Soc Trans* **28**, 979–981.
- Abu-Ashour, J., Joy, D.M., Lee, H., Whiteley, H.R. and Zelin, S. (1994). Transport of microorganisms through soil. *Water Air Soil Pollut* **75**, 141–157.
- Agarwal, A.K. and Das, L.M. (2001). Biodiesel development and characterization for use as a fuel in compression ignition engines. *J Eng Gas Turbines Power* **123**, 440–447.
- Ahring, B.K., Mladenovska, Z., Iranpour, R. and Westermann, P. (2002). State of the art and future perspectives of thermophilic anaerobic digestion. *Water Sci Technol* **45**, 298–308.
- Almosnino, A.M., Belin, J.M. (1991). Apple pomace: an enzyme system for producing aroma compounds from polyunsaturated fatty acids. *Biotechnol Lett* **13**(12), 893–898.
- Alvarez, M., Gagné, S. and Antoun, H. (1995). Effect of compost on rhizosphere microflora of the tomato and on the incidence of plant growth-promoting rhizobacteria. *Appl Environ Microbiol* **61**, 194–199.
- Al-Widyan, M.I. and Al-Shyoukh, A.O. (2002). Experimental evaluation of the transesterification of waste palm oil into biodiesel. *Bioresource Technol* **85**(3), 253–256.
- Anthony, E.J. (1995). Fluidized bed combustion of alternative solid fuels; status successes and problems of the technology. *Progress Energy Combust Sci* **21**, 239–268.
- Arogba, S.S. (1999). The performance of processed mango (*Mangifera indica*) kernel flour in a model food system. *Bioresource Technol* **70**, 277–281.
- Asther, M. *et al.* (1997). Fungal biotransformation of European agricultural by-products to natural vanillin: a two-step process. *Food Ingredients* Porte de Versailles, Paris, France, 12–14 November 1996, pp. 123–125.

- Azbar, N. and Yonar, T. (2004). Comparative evaluation of a laboratory and full-scale treatment alternatives for the vegetable oil refining industry wastewater (VORW). *Process Biochem* **39**(7), 869–875.
- Baarth, J. (1999). Compost quality, quality assurance and use: the basis for sustainable organic waste management in Europe. In *Proceedings of the International Composting Symposium (ICS'99), Halifax, Nova Scotia, Canada* (P.R. Warman and B.R. Taylor, eds), vol. I, pp. 14–32. CBA Press, Truro, Canada.
- Ball, A.S., Shah, D. and Wheatley, C.F. (2000). Assessment of the potential of a novel newspaper/horse manure-based compost. *Bioresource Technol* **73**, 163–167.
- Baziramakenga, R., Simard, R.R. and Lalonde, R. (2001). Effect of de-inking paper sludge compost application on soil chemical and biological properties. *Can J Soil Sci* **81**, 561–575.
- Bazzoffi, P., Pellegrini, S., Rocchini, A., Morandi, M. and Grasselli, O. (1998). The effect of urban refuse compost and different tractor tires on soil physical properties, soil erosion and maize yield. *Soil Tillage Res* **48**, 275–286.
- Bench, M.L., Woodard, R., Harderand, M.K. and Stantzos, N. (2005). Waste minimisation: home digestion trials of biodegradable waste. *Resources Conservat Recycl* **45**(1), 84–94.
- Bengston, G.W. and Cornette, J.J. (1973). Disposal of composted municipal waste in a plantation of young slash pine: effects on soil and trees. *J Environ Qual* **2**, 441–444.
- Bonnin, E. *et al.* (1999). Enhanced bioconversion of vanillic acid into vanillin by the use of 'natural' callobiose. *J Sci Food Agricult* **79**, 484–486.
- Borycka, B. (1996). Fruit pomace in new dietary fiber compositions. *Przemysl-Fermentacyjny-i-Owocowo-Warzywny (Poland)*, **40**(12), 37–39.
- Bouallagui, H., BenCheikh, R., Marouani L. and Hamdi, M. (2003). Mesophilic biogas production from fruit and vegetable waste in tubular digester. *Bioresource Technol* **86**, 85–89.
- Bouallagui, H., Haouari, O., Touhami, Y., Cheikh, R. Ben, Marouani, L. and Hamdi, M. (2004). Effect of temperature on the performance of an anaerobic tubular reactor treating fruit and vegetable waste. *Process Biochem* **39**(12), 2143–2148.
- Bouallagui, H., Torrijos, M., Godon, J.J. *et al.* (2004). Two-phases anaerobic digestion of fruit and vegetable wastes: bioreactors performance. *Biochem Engin J* **21**(2), 193–197.
- Bouallagui, H., Touhami, Y., Cheikh, R.B. and Hamdi, M. (2005). Bioreactor performance in anaerobic digestion of fruit and vegetable wastes. *Process Biochemistry* **40**(3–4), 989–995.
- Boyer, M.J. (1996). Environmental impact and waste management, 5th edn. *Bailey's Industrial Oil and Fat Products*, Vol. 14. Wiley, New York.
- Brinton, W.F. (1985). Nitrogen response of maize to fresh and composted manure. *Biol Agricult Horticult* **3**, 55–64.
- Broughton, N.W., Dalton, C.C., Jones, G.C. and Williams, E.L. (1995a). Adding value to sugar beet pulp. *Hoehere Erloese aus Zuckerruebenschneitzeln Zuckerindustrie* **120**(5), 411–416.
- Broughton, N.W., Dalton, C.C., Jones, G.C. and Williams, E.L. (1995b). Adding value to sugar beet pulp. *Int Sugar J* **97**(1154), 57–60, 93–95.

- Bulluck, L.R., Brosius, M., Evanylo, G.K. and Ristaino, J.B. (2002). Organic and synthetic fertility amendments influence soil microbial, physical and chemical properties on organic and conventional farms. *Appl Soil Ecol* **19**(2), 147–160.
- Callaghan, F.J., Wase, D.A.J., Thayanithy, K. and Forster, C.F. (2002). Continuous co-digestion of cattle slurry with fruit and vegetable wastes and chicken manure. *Biomass Bioenergy* **22**(1), 71–77.
- Carson, K.J., Collins, J.L. and Penfield, M.P. (1994). Unrefined, dried apple pomace as a potential food ingredient. *J Food Sci* **59**(6), 1213–1215.
- Cavaleiro, A.J., Alves, M.M. and Mota, M. (2001). Microbial and operational response of an anaerobic fixed bed digester to oleic acid overloads. *Process Biochem* **37**, 387–394.
- Chian, E.S.K. and Dewalle, F.B. (1977). Treatment of high strength acidic wastewater with completely mixed anaerobic filter. *Water Res* **11**, 295.
- Chipasa, K.N. (2001). Limits of physicochemical treatment of wastewater in the vegetable oil refining industry. *Pol J Environ Stud* **10**(3), 141–147.
- Chkhikvishvili, I.D. and Gogiya, N.N. (1995). Flavonoids of mandarin fruit wastes and their fungistatic effect on the fungus *Phoma tracheiphila*. *Appl Biochem Microbiol* **31**(3), 292–296.
- Clarke, S. (1995). Eat bagasse. *Sugar J* **58**, 12–14.
- Clemente, A., Sanchez-Vioque, R., Vioque, J., Bautista, J. and Millan, F. (1997). Chemical composition of extracted dried olive pomaces containing two and three phases. *Food Biotechnol* **11**(3), 273–291.
- Cliffe, K.R. and Patumsawad, S. (2001). Co-combustion of waste from olive oil production with coal in a fluidised bed. *Waste Manage* **21**, 49–53.
- Couteau, D. and Mathaly, P. (1998). Fixed-bed purification of ferulic acid from sugar beet pulp using activated carbon: optimization studies. *Bioresource Technol* **60**, 17–25.
- Dague, R.R., Habben, C.E. and Pidaparti, S.R. (1992). Initial studies on the anaerobic sequencing batch reactor. *Water Sci Technol* **26**, 2429–2432.
- De Neve, S., Gaona Sáez, S., Chaves Daguilar, B., Sleutel, S. and Hofman, G. (2004). Manipulating N mineralization from high N crop residues using on- and off-farm organic materials. *Soil Biology Biochem* **36**(1), 127–134.
- De Neve, S., Sleutel, S. and Hofman, G. (2003). Carbon mineralization from composts and food industry wastes added to soil. *Nutr Cycl Agroecosyst* **67**, 13–20.
- Dexter, J.E. and Wood, P.J. (1996). Recent applications of debranning of wheat before milling. *Trends Food Sci Technol* **7**(2), 35–41.
- Diener, R.G., Collins, A.R., Martin, J.H. and Bryan, W.B. (1993). Composting of source-separated municipal solid waste for agricultural utilization – a conceptual approach for closing the loop. *Appl Eng Agric* **9**, 427–436.
- Dmytryshyn, S.L., Dalai, A.K., Chaudhari, S.T., Mishra, H.K. and Reaney, M.J. (2004). Synthesis and characterization of vegetable oil derived esters: evaluation for their diesel additive properties. *Bioresource Technol* **92**(1), 55–64.
- Duerre, P. (1998). New insights and novel developments in clostridial acetone/butanol/isopropanol fermentation. *Appl Microbiol Biotechnol* **49**, 639–648.
- Duggan, J.C. and Wiles, C.C. (1976). Effects of municipal compost and nitrogen fertilizer on selected soils and plants. *Compost Sci* **17**, 24–31.

- Edwards, L., Burney, J.R., Richter, G. and MacRae, A.H. (2000). Evaluation of compost and straw mulching on soil-loss characteristics in erosion plots of potatoes in Prince Edward Island, Canada. *Agricult Ecosys Environ* **81**(3), 217–222.
- Entry, J.A., Leytem, A.B. and Verwey, S. (2005). Influence of solid dairy manure and compost with and without alum on survival of indicator bacteria in soil and on potato. *Environmen Pollut* **138**(2), 212–218.
- Entry, J.A. and Sojka, R.E. (2000). The efficacy of polyacrylamide related compounds to remove microorganisms and nutrients from animal wastewater. *J Environmen Qual* **29**, 1905–1914.
- Entry, J.A., Hubbard, R.K., Thies, J.E. and Furhmann, J.J. (2000a). The influence of vegetation in riparian filterstrips on coliform bacteria I. Movement and survival in surface flow and groundwater. *J Environ Qua* **29**, 1206–1214.
- Entry, J.A., Hubbard, R.K., Thies, J.E. and Furhmann, J.J. (2000b). The influence of vegetation in riparian filterstrips on coliform bacteria II. Survival in soil. *J Environ Qual* **29**, 1215–1224.
- Entry, J.A., Phillips, I., Stratton, H. and Sojka, R.E. (2003). Efficacy of polyacrylamide + $\text{Al}(\text{SO}_4)_3$ and polyacrylamide + CaO to filter microorganisms and nutrients from animal wastewater. *Environ Pollut* **121**, 453–462.
- Evanylo, G.K. and Daniels, W.L. (1999). Paper mill sludge composting and compost utilization. *Compos Sci Utiliz* **7**(2), 30–39.
- FAO (2001–2004). *Agricultural data*. FAOSTAT, Rome.
- Fernández, A., Sánchez, A. and Font, X. (2005). Anaerobic co-digestion of a simulated organic fraction of municipal solid wastes and fats of animal and vegetable origin. *Biochem Engin J* **26**(1), 22–28.
- Filipini, M. and Hogg, T. (1997). Upgrading of vegetable wastes and applications in the food industry. In *11 Forum for Applied Biotechnology, Gent (Belgium)*, 25–26 September 1997, 62(4a), pp. 1329–1331. Mededelingen-Faculteit-Landbouwkundigen-Toegepaste-Biologische-Wetenschappen-Universiteit-Gent (Belgium).
- Gagliardi, J.V., Millner, P.D., Lester, G. and Ingram, D. (2003). On-farm and postharvest processing sources of bacterial contamination to melon rinds. *Food Protect* **66**, 82–87.
- Gagnon, B., Lalande, R. and Fahmy, S.H. (2001). Organic matter and aggregation in a degraded potato soil as affected by raw and composted pulp residue. *Biol Fert Soils* **34**, 441–447.
- Gallardo-Lara, F. and Nogales, R. (1987). Effect of the application of town refuse compost on the soil–plant system: a review. *Biol Wastes* **19**, 35–62.
- Giusquiani, P., Pagliai, M., Gigliotti, G., Businelli, D. and Benetti, A. (1995). Urban waste compost: effects on physical, chemical and biochemical soil properties. *J Environ Qual* **24**, 175–182.
- Gómez, X., Cuetos, M.J., Cara, J., Morán, A. and García, A.I. (2006). Anaerobic co-digestion of primary sludge and the fruit and vegetable fraction of the municipal solid wastes. Conditions for mixing and evaluation of the organic loading rate. *Renewable Energy* **31**, 2017–2024.
- Grigelmo-Miguel, N. and Martin-Belloso, O. (1999). Influence of fruit dietary fibre addition on physical and sensorial properties of strawberry jams. *J Food Engin* **41**, 13–21.

- Gunaseelan, V.N. (2004). Biochemical methane potential of fruits and vegetable solid waste feedstocks. *Biomass Bioenergy* **26**(4), 389–399.
- Haas, M.J., Bloomer, S. and Scott, K. (2000). Simple, high-efficiency synthesis of fatty acid methyl esters from soapstock. *JAACS* **77**(4), 373–379.
- Haas, M.J., Michalski, P.J., Runyon, S., Nunez, A. and Scott, K.M. (2003). Production of FAME from acid oil, a by-product of vegetable oil refining. *JAACS* **80**(1), 97–102.
- Haas, M.J., Scott, K.M., Alleman, T.L. and McCormick, R.L. (2001). Engine performance of biodiesel fuel prepared from soybean soapstock: a high quality renewable fuel produced from a waste feedstock. *Energy Fuels* **15**(5), 1207–1212.
- Hamdi, M. (1996). Anaerobic digestion of olive mill wastewater: a review. *Process Biochem* **31**, 105–110.
- Hara-Kudo, Y., Konuma, H., Iwki, M. *et al.* (1997). Potential hazard of raddish sprouts as a vehicle of *Escherichia coli* O157:H7. *J Food Protect* **60**, 1125–1127.
- He, Z., Yang, X., Kahn, B.A., Stoffella, P.J. and Calvert, D.V. (2000). Plant nutrition benefits of phosphorus, potassium, calcium, magnesium and micronutrients from compost utilization. In *Compost utilization in horticultural cropping systems* (P.J. Stoffella and B.A. Kahn, eds), pp. 307–320. Lewis Publishers, Boca Raton.
- Henn, T. (1998). Untersuchungen zur Entwicklung und Bewertung funktioneller Lebensmittelzutaten aus Reststoffen am Beispiel von Mohrentrestern und ihrer Anwendung in Getranken (Thesis Bonn/D 1998) Cuvillier Verlag Gottingen.
- Henn, T. and Kunz, B. (1996). Zum Wegwerfen zu Schade. (Teil 1) – Multifunctional Ingredients from Low-Residue Food Production. *ZFL* **47**(1/2), 21–23.
- Iglesias-Jiménez, E. and Alvarez, C.E. (1993). Apparent availability of nitrogen in composted municipal refuse. *Biol Fertil Soils* **16**, 313–318.
- Ilyin, V.K., Smirnov, I.A., Soldatov, P.E. *et al.* (2004). Microbial utilisation of natural organic wastes. *Acta Astronaut* **54**(5), 357–361.
- Ilyin, V.K., Korniuschenkova, I.N., Starkova, L.V. and Lauriniavichius, K.S. (2005). Study of methanogenesis during bioutilization of plant residuals. *Acta Astronaut* **56**(4), 465–470.
- Ingelmo, F., Canet, R., Ibañez, M.A., Pomares, F. and García, J. (1997). Use of MSW compost, dried sewage sludge and other wastes as partial substitutes for peat and soil. *Commun Soil Sci Plant Anal* **27**, 1859–1874.
- Inglett, G.E. (1998). New cereal products with health benefits. *Food ingredients*, Europe, Conference Proceedings, pp.17–19.
- Islam, M., Doyle, M.P., Phatak, S.C., Millner, P. and Jiang, X. (2004). Persistence of enterohemorrhagic *Escherichia coli* O157:H7 in soil and on leaf lettuce and parsley grown in fields treated with contaminated manure composts or irrigation water. *J Food Protect* **67**, 1365–1370.
- Jackson, M.J., Line, M.A., Wilson, S. and Hetherington, S.J. (2000). Application of composted pulp and paper mill sludge to a young pine plantation. *J Environ Qual* **29**, 407–414.
- Joshi, V.K. and Sandhu, D.K. (1996). Preparation and evaluation of an animal feed byproduct produced by solid-state fermentation of apple pomace. *Bioresource Technology* **56**(2/3), 251–255.
- Kaieda, M., Samukawa, T., Matsumoto, T., Ban, M., Kondo, A. and Shimada, Y. (1999). Biodiesel fuel production from plant oil catalyzed by *Rhizopus oryzae* lipase in a

- water-containing system without an organic solvent. *J Biosci Bioengin* **88**(6), 627–631.
- Kale, V., Katikaneni, S.S.P. and Cheryan, M. (1999). Deacidification of ricebran oil by solvent extraction and membrane technology. *J Am Oil Chem Soc* **76**(6), 723.
- Kamini, N.R. and Iefuji, H. (2001). Lipase catalyzed methanolysis of vegetable oils in aqueous medium by *Cryptococcus* spp. S-2. *Process Biochem* **37**, 405–410.
- Kettunen, R.H. and Rintala, J.A. (1997). The effect of low temperature (5–29°C) and adaption on the methanogenic activity of biomass. *Appl Microbiol Biotechnol* **48**, 570–576.
- Koksel, H. and Ozboy, O. (1999). Effects of sugar beet fiber on cookie quality. *Zuckerindustrie* **124**(7), 542–544.
- Lane, A.G. (1984). Anaerobic digestion of solid fruit waste supplemented with poultry manure in a horizontal plug-flow reactor. *Environ Technol Lett* **5**, 465–471.
- Lara Pizarro, A.V. and Park, E.Y. (2003). Lipase-catalyzed production of biodiesel fuel from vegetable oils contained in waste activated bleaching earth. *Process Biochem* **38**(7), 1077–1082.
- Larrauri, J.A. (1999). New approaches in the preparation of high dietary fibre powders from food by-products. *Trends Food Sci Technol* **10**(1), 3–8.
- Laufenberg, G., Gruß, O. and Kunz, B. (1996). Neue Konzepte der Reststoffverwertung in der Lebensmittelindustrie – Chancen für die Kartoffelstarkeindustrie. (New concepts for the utilisation of residual products from food industry – Prospects for the potato industry.) *Starch-Starke* **48**(9), 315–321.
- Laufenberg, G., Kunz, B. and Nystroem, M. (2003). Transformation of vegetable waste into value added products: (A) the upgrading concept; (B) practical implementations. *Bioresource Technol* **87**, 167–198.
- Laufenberg, G.H. and Cussler, E.L. (1999). Recovery of bioflavours by hollow fibre membrane contactors. In *Euromembrane 99*, 19–22 September, 1999. Leuven, Belgium, pp. 317–318.
- Lesage-Meessen, L. *et al.* (1999). Fungal transformation of ferulic acid from sugar beet pulp to natural vanillin. *J Sci Food Agricult* **79**, 487–490.
- Levy, S.J. and Taylor, B.R. (2003). Effects of pulp mill solids and three composts on early growth of tomatoes. *Bioresource Technol* **89**(3), 297–305.
- Lissens, G., Vandevivere, P., De Baere, L., Biey, E.M. and Verstrae, W. (2001). Solid waste digesters: process performance and practice for municipal solid waste digestion. *Water Sci Technol* **44**, 91–102.
- Lucas, J. (1997). Fermentative utilization of fruit and vegetable pomace (biowaste) for the production of novel types of products—results of an air project. In *Proceedings of the eleventh forum for applied biotechnology*, Gent, Belgium, 25–26 September, 1997, Part II, 62(4b), 1865–1867. Mededelingen-Faculteit-Landbouwkundige-en-Toegepaste-Biologische-Wetenschappen, Universiteit-Gent.
- Mallin, M.A., Burkholder, J.M., McIver, M.R. *et al.* (1997). Comparative effects of poultry and swine waste lagoon spills on the quality of receiving waters. *J Environ Qual* **26**, 1622–1631.
- Manios, T. (2004). The composting potential of different organic solid wastes: experience from the island of Crete. *Environ Int* **29**(8), 1079–1089.

- Manthey, J.A. and Grohmann, K. (1996). Concentrations of Hesperidin and other orange peel flavonoids in citrus processing by-products. *J Agricult Food Chem* **44**, 811–814.
- Masoodi, F.A. and Chauhan, G.S. (1998). Use of apple pomace as a source of dietary fiber in wheat bread. *J Food Process Preserva* **22**, 255–263.
- Mata-Alvarez, J., Cecchi, F., Llabrés, P. and Pavan, P. (1992). Anaerobic digestion of the Barcelona central food market organic wastes: experimental study. *Bioresource Technol* **39**, 39–48.
- Mata-Alvarez, J., Macé, S. and Llabrés, P. (2000). Anaerobic digestion of organic solid wastes. An overview of research achievements and perspectives. *Bioresource Technol* **74**, 3–16.
- Mays, D.A., Terman, G.L. and Duggan, J.C. (1973). Municipal compost: effects on crop yields and soil properties. *J Environ Qual* **2**, 89–92.
- McGowin, C.R. and Howe, W.C. (1994). Alternative fuel cofiring in fluidized bed boilers. In *Proceedings of the 1994 Industrial Power Conference*, PWR, Vol. 24, pp. 155–170. American Society of Mechanical Engineers (ASME).
- Misi, S.N. and Forster, C.F. (2002). Semi-continuous anaerobic co-digestion of agro-waste. *Environ Technol* **23**, 445–451.
- Mittelbach, M. (1990). Lipase catalyzed alcoholysis of sunflower oil. *JAOCS* **61**(3), 168–170.
- Mkhabela, M.S. and Warman, P.R. (2005). The influence of municipal solid waste compost on yield, soil phosphorus availability and uptake by two vegetable crops grown in a Pugwash sandy loam soil in Nova Scotia. *Agricult Ecosys Environ* **106**(1), 57–67.
- Murto, M., Björnsson, L. and Mattiasson, B. (2004). Impact of food industrial waste on anaerobic co-digestion of sewage sludge and pig manure. *J Environ Manage* **70**(2), 101–107.
- Nawirska, A. and Kwasniewska, M. (2005). Dietary fibre fractions from fruit and vegetable processing waste. *Food Chem* **91**(2), 221–225.
- Nelson, L.A., Foglia, T.A. and Marmer, W.N. (1996). Lipase-catalyzed production of biodiesel. *JAOCS* **73**, 1191–1195.
- Nevens, F. and Reheul, D. (2003). The application of vegetable, fruit and garden waste (VFG) compost in addition to cattle slurry in a silage maize monoculture: nitrogen availability and use. *Eur J Agron* **19**(2), 189–203.
- Offord, C.A., Muir, S. and Tyler, J.L. (1998). Growth of selected Australian plants in soil-less media using coir as a substitute for peat. *Aust J Exp Agric* **38**, 879–887.
- Ohsawa, K., Chinen, C., Takanami, S., Kuribayashi, T. and Kurokouchi, K. (1994). Studies on effective utilization of carrot pomace, 1: Effective utilization to bread. Research Report of the Nagano State Laboratory of Food Technology Japan, **22**, 24–28.
- Ohsawa, K., Chinen, C., Takanami, S., Kuribayashi, T. and Kurokouchi, K. (1995). Studies on effective utilization of carrot pomace, 2: Effective utilization to cake, dressing and pickles. Research Report of Food Technology Research Institute of Nagano Prefecture, Japan, **23**, 15–18.
- Ozores-Hampton, M. and Obreza, T.A. (1999a). Composted waste use on Florida vegetable crops: a review. In *Proceedings of the International Composting Symposium*

- (ICS'99), Halifax, Nova Scotia, Canada (P.R. Warman and B.R. Taylor, eds), Vol. I, pp. 827–842. CBA Press, Truro, Canada.
- Ozores-Hampton, M., Vavrina, C.S. and Obreza, T.A. (1999b). Yard trimmin-biosolids compost: possible alternative to sphagnum peat moss in tomato transplant production. *Compost Sci Utiliz* **7**, 42–49.
- Page, C., Fuller, C. and Autenrieth, R. (2000). Materials balance on an oil washed from a sandy substrate using shoreline cleaners. In *Proceedings of the Twenty-third Arctic and Marine Oil Spill Programme*, pp. 697–708. Technical Seminar. Environment Canada, Vancouver.
- Pandey, R.A., Sanyal, P.B., Chattopadhyay, N. and Kaul, S.N. (2003). Treatment and reuse of wastes of a vegetable oil refinery. *Resources Conservat Recyc* **37**(2), 101–117.
- Park, E.Y. and Mori, M. (2005). Kinetic study of esterification of rapeseed oil contained in waste activated bleaching earth using *Candida rugosa* lipase in organic solvent system. *J Mol Catal B: Enzymatic* **37**(1–6), 95–100.
- Park, E. Y. and Ming, H. (2004). Oxidation of rapeseed oil in waste activated bleaching earth and its effect on riboflavin production in culture of *Ashbya gossypii*. *J Biosci Bioengin* **97**(1), 59–64.
- Pereira, M. G. and Mudge, S. M. (2004). Cleaning oiled shores: laboratory experiments testing the potential use of vegetable oil biodiesels. *Chemosphere* **54**(3), 297–304.
- Pfotzer, G.H. and Schüller, C. (1997). Effects of different compost amendments on soil biotic and faunal feeding activity in an organic farming system. *Biol Agricult Horticult* **15**, 177–183.
- Pinacho, A., García-Encina, P.A., Sancho, P., Ramos, P. and Márquez, M.C. (2006). Study of drying systems for the utilization of biodegradable municipal solid wastes as animal feed. *Waste Manage* **26**(5), 495–503.
- Prasertsan, S. and Prasertsan, P. (1996). Biomass residues from palm oil mills in Thailand: an overview on quantity and potential usage. *Biomass Bioenergy* **11**(5), 387–395.
- Pugazhvidivu, M. and Jeyachandran, K. (2005). Investigations on the performance and exhaust emissions of a diesel engine using preheated waste frying oil as fuel. *Renewable Energy* **30**(14), 2189–2202.
- Purchase, B. (1995). Products from sugarcane. *Int Sugar J* **97**(1154), 70–71.
- Rodriguez-Kabana, R., Estaun, V., Pinochet, J. and Marfa, O. (1995). Mixtures of olive pomace with different nitrogen sources for the control of *Meloidogyne spp.* on tomato. *J Nematol* **27**(45), 575–584.
- Ruynal, J., Delgenes J.P. and Moletta, R. (1998). Two phase anaerobic digestion of solid waste by a multiple liquefaction reactors process. *Bioresource Technol* **65**, 97–103.
- Sachindra, N.M. and Mahendrakar, N.S. (2005). Process optimization for extraction of carotenoids from shrimp waste with vegetable oils. *Bioresource Technol* **96**(10), 1195–1200.
- Sachs, J.V., Meyer, U., Rys, P. and Feikenhauer, H. (2003). New approach to control the methanogenic reactor of a two-phase anaerobic digestion system. *Water Res* **37**, 973–982.
- Sanchez-Rabaneda, F.S., Jáuregui, O., Lamuela-Raventós, R.M., Bastida, J., Viladomat, F. and Codina, C. (2003). Identification of phenolic compounds in artichoke waste by high-performance liquid chromatography–tandem mass spectrometry. *J Chromatogr A* **1008**(1), 57–72.

- Saura-Calixto, F. (1998). Antioxidant dietary fiber product: a new concept and a potential food ingredient. *J Agricult Food Chem* **46**(10), 4303–4306.
- Schroder, T. (1999). Verkapselt und funktionell. *Lebensmitteltechnik* **6**, 48–50.
- Schüler, C., Pikny, J., Nasir, M. and Vogtmann, H. (1993). Effects of composted organic kitchen and garden waste on *Mycosphaerella pinodes* (Ber. Et Blox) Vestergr., causal organism of foot rot on peas (*Pisum sativum* L.). *Biol Agricult Horticult* **9**, 353–360.
- Seto, K.H. and Frank, J.F. (1999). Attachment of *Escherichia coli* O157:H7 to leaf surface and bacterial viability in response to chlorine treatment as demonstrated by using confocal scanning laser microscopy. *J Food Protect* **62**, 3–9.
- Shinohara, Y., Hata, T., Mauro, T., Hohjo, M. and Ito, T. (1999). Chemical and physical properties of the coconut-fiber substrate and the growth and productivity of tomato (*Lycopersicon esculentum* Mill) plants. *Acta Hort* **481**, 145–149.
- Shyamala, B.N., Gupta, S., Lakshmi, A. J. and Prakash, J. (2005). Leafy vegetable extracts – antioxidant activity and effect on storage stability of heated oils. *Innovat Food Sci Emerg Technol* **6**(2), 239–245.
- Simard, R.R., Baziramakenga, R., Yelle, S. and Coulombe, J. (1998). Effects of de-inking paper sludges on soil properties and crop yields. *Can J Soil Sci* **78**, 689–697.
- Spackman, R., Entry, J.A., Sojka, R.E. and Ellsworth, J.W. (2003). Polyacrylamide for coliform bacteria removal from agricultural waste water in irrigated forage production. *J Soil Water Conservat* **58**, 276–283.
- Sreenath, H.K., Crandall, P.G., Baker, R.A. (1995). Utilization of citrus by-products and wastes as beverage clouding agents. *J Ferment Bioengin* **80**(2), 190–194.
- Srilatha, H.R., Krishna, N., Sudhakar Bada, K. and Madhukara, K. (1995). Fungal pretreatment of orange processing waste by solid state fermentation for improved production of methane. *Process Biochem* **30**, 327–331.
- Stabnikova, O., Wang, J-Y., Ding, H.B. and Tay, J-H. (2000). Biotransformation of vegetable and fruit processing wastes into yeast biomass enriched with selenium starch industry. *Starch-Starke*, **48**, 315–321.
- Stickelberger, D. (1977). The problem of the fast and slow cycles of fertilization. *Compost Sci (May/June)* **18**, 12–20.
- Stock, U. (1999). Am Koerper der Suppe Wo kommt eigentlich der Geschmack her? *Zeit* **52**(36), 22.12.99.
- Suksankraisorn, K., Patumsawad, S. and Fungtammasan, B. (2003). Combustion studies of high moisture content waste in a fluidised bed. *Waste Manage* **23**(5), 433–439.
- Tagesschau 2.11.1999, Strom aus Kaffeesatz. HTML version der Tagesschau/ARD, <http://www.tagesschau.de/archiv/1999/11/02/akruell/meldungen/kaffee?>
- Tashtoush, G., Al-Widyan, M.I. and Al-Shyoukh, A.O. (2003). Combustion performance and emissions of ethyl ester of a waste vegetable oil in a water-cooled furnace. *Appl Thermal Engin* **23**(3), 285–293.
- Tokimoto, T., Kawasaki, N., Nakamura, J., Akutagawa, J. and Tanada, S. (2005). Removal of lead ions in drinking water by coffee grounds as vegetable biomass. *J Colloid Interface Sci* **281**(1), 56–61.
- Toma, R.B. (1979). Physical and chemical properties of potato peel as a source of dietary fiber in bread. *J Food Sci* **44**, 1403–1407, 1417.

- Urrestarazu, M., Martínez, G. A. and del Carmen Salas, C.M. (2005). Almond shell waste: possible local rockwool substitute in soilless crop culture. *Sci Horticult* **103**(4), 453–460.
- USEPA (1998). United States Environmental Protection Agency, Office of Water, Standards and Applied Sciences Division. *Environmental impacts of animal feeding operations. Preliminary data summary*. Feedlots Point Source Category Study, US EPA/Office of Water, 401 M St SW 4303, Washington, DC.
- Usta, N., Öztürk, E., Can, Ö. *et al.* (2005). Combustion of biodiesel fuel produced from hazelnut soapstock/waste sunflower oil mixture in a diesel engine. *Energy Conversion Manage* **46**(5), 741–755.
- Valdés, A.F. and Garcia, A.B. (2006). On the utilization of waste vegetable oils (WVO) as agglomerants to recover coal from coal fines cleaning wastes (CFCW). *Fuel* **85**(5–6), 607–614.
- Valdés, A.F. and Garcia, A.B. (2006). A study of the evolution of the physicochemical and structural characteristics of olive and sunflower oils after heating at frying temperatures. *Food Chem* **98**(2), 214–219.
- Verrier, D., Ray, F. and Albagnac, G. (1987). Two-phase methanization of solid vegetable wastes. *Biol Wastes* **22**, 163–177.
- Viswanath, P., Devi, S.S. and Nand, K. (1992). Anaerobic digestion of fruit and vegetable processing wastes for biogas production. *Bioresource Technol* **40**, 43–48.
- Von Wedel, R. (1997). The CytoSol process: cleaning oiled shorelines with a vegetable oil biosolvent. *Port Technol Int* **7**, 209–212.
- Wadhwa, M., Kaushal, S. and Bakshi, M.P.S. (2006). Nutritive evaluation of vegetable wastes as complete feed for goat bucks. *Small Ruminant Res* **64**(3), 279–284.
- Watanabe, Y., Shimada, Y., Sugihara, A., Noda, H., Fukuda, H. and Tominaga, Y. (2000). Continuous production of biodiesel fuel from vegetable oil using immobilized *Candida antarctica* lipase. *JAACS* **77**(4), 355–359.
- Widmer, W. and Montanari, A.M. (1995). Citrus waste streams as a source of phytochemicals. In *107th Annual Meeting of the Florida State Horticultural Society*, Orlando, Florida, vol. 107, pp. 284–288.
- Zeller, B.L. (1999). Development of porous carbohydrate food ingredients for the use in flavour encapsulation. *Trends Food Sci Technol* **9**(11–12), 389–394.
- Zhang, X., Peterson, C., Reece, D., Haws, R. and Moller, G. (1998). Biodegradability of biodiesel in the aquatic environment. *Trans ASAE* **41**, 1423–1430.
- Zhang, Y., Dubé, M.A., McLean, D.D. and Kates, M. (2003). Biodiesel production from waste cooking oil: 1. Process design and technological assessment. *Bioresource Technol* **89**(1), 1–16.

This page intentionally left blank

Waste Treatment Methodologies of Foods of Animal Origin

PART

5

- | | | |
|----|--|-----|
| 12 | Meat Waste Management: Treatment Methods and Potential
Uses of Treated Waste | 765 |
| 13 | Dairy Waste Management: Treatment Methods and Potential
Uses of Treated Waste | 801 |
| 14 | Fish Waste Management: Treatment Methods and Potential
Uses of Treated Waste | 861 |

This page intentionally left blank

Meat Waste Management: Treatment Methods and Potential Uses of Treated Waste

Ioannis S. Arvanitoyannis and Demetrios Ladas

Introduction	765
Primary treatment	768
Secondary treatment	771
Uses	782

Introduction

The food and agro-allied industries usually produce large amounts of wastes and, where adequate disposal systems are unavailable, such wastes cause environmental problems. In the meat industry, the slaughtering process is the largest contributor to liquid waste (Benka-Coker and Ojioro, 1995). Animal waste may be defined as carcasses or parts of animals, including products of animal origin not intended for direct human consumption (Commission of the European Communities, 1990).

Ramirez *et al.* (2006) analyzed energy use and energy efficiency developments for the meat industry of four European countries in the last decade. Results show that, during this time, there has been an increase in both energy demand and specific energy consumption in the meat industry of the four countries analyzed (between 14% and 32%) (Table 12.1). In exploring the causes for such trends, it was found that strict hygiene regulations can explain up to two-thirds of the increase in energy efficiency indicator (EEI) and that the role of increasing shares of freezing and cutting fresh meat is quite limited in all countries. There is, however, a significant share of the increase in

Table 12.1 Energy consumption in the meat industry

Sector	Electricity Activity	%	Fuels Activity	%
Pork slaughtering	Cooling	49–70	Gas oven	60–65
	Slaughtering	5–30	Cleaning and disinfecting	18–20
	Water cleaning	5–7	Singeing	15
	Lighting	2–8		
	Evisceration	3	Space heating	7
Cattle slaughtering	Slaughtering	26	Cleaning and disinfecting	80–90
	Evisceration	3		
	Cooling	45–70		
	Compressed air, lighting and machines	30	Space heating	10–20
Poultry slaughtering	Cooling	52–60	Singeing	60
	Machines and compressed air	30	Cleaning and disinfecting	30
	Lighting and ventilation	4	Space heating	10
Meat processing	Cutting and mixing	40	Cleaning and disinfecting	25
	Cooling	40	Space heating	15
	Packing	10		
	Lighting	10		

Adapted from <http://eippcb.jrc.es/pages/BActivities.cfm>; Pontopiddan and Hansen, 2001; Ramirez *et al.*, 2006

the EEI that could not be explained. A possible cause is an increase in energy intensive process in the further processed meat sector, however, further analysis was halted due to lack of current available data. Understandably, when looking at the meat sector, studies on processes and hygiene have focused their attention on slaughterhouses; not only are they considered an important source of epidemics but also have a limited number of processes. On the other hand, only very little attention has been paid to the further processed meat sector, with more than 40 different product categories. Despite a couple of studies, which deal with sausage-making, there is no information available on Size Exclusion Chromatography by-products which imply that changes in structure within the further processed meat sector remain in the EEI.

The magnitude of poultry waste generation in Hong Kong led to improper disposal, including over application and improperly timed application for crop nutrient demands. Such practices could lead to serious environmental problems, such as increased nutrient loss through leaching, erosion and runoff from agricultural fields (Vervoort *et al.*, 1998; Tiquia *et al.*, 2002; Tiquia and Tam, 2002). Furthermore, Salminen and Rintala (2002) reported that, because of legal restrictions, rising treatment costs and environmentally conscious consumers, the treatment of some solid residues and wastes and, particularly, residues from wastewater treatment processes emerged as a major concern in meat industries.

In an early work, the waste originating from Danish farm production amounted to $40\text{--}50 \times 10^6$ metric tonnes of solid and fluid manure. Moreover, the water used in

dairy plants and slaughterhouses amounts to approximately $40 \times 10^6 \text{ m}^3$ per year, which equals the amount of water used by 500 000 people. However, the wastewater from these plants was so heavily contaminated with organic matter and chemicals that it required a purifying capacity matching $1.8\text{--}2.0 \times 10^6$ person equivalents to render this water acceptable for streams and lakes (Andersen and Aalund, 1975).

Large livestock and poultry farms produce a considerable amount of waste. In the St Petersburg region alone, there are approximately 11×10^6 poultry (400 000–450 000 tonnes of dung per year), 150 000 pigs ($1.5 \times 10^6 \text{ m}^3$ of liquid waste per year) and 220 000 livestock (Arkhipchenko *et al.*, 2005).

About 344 slaughterhouse factories are located in Thailand and most of them are around the Bangkok area. The wastewaters from these industries contain mainly organic matter (chemical oxygen demand (COD) or biochemical oxygen demand (BOD_5)), oil and grease and nitrogenous compounds (proteins and amino acids) (Sirianuntapiboon and Yommee, 2006). Pollutant parameters of importance to the meat industry are BOD_5 , COD, total dissolved solids, suspended solids, FOG (fats, oils and greases) and color and water usage (Carawan *et al.*, 1979). In general, slaughterhouse effluents increase nitrogen, phosphorus, solids and BOD_5 levels of the receiving water body, potentially leading to eutrofication (Benka-Coker and Ojioro, 1995).

A definite analysis of the waste characteristics of the meat packing industry is not a simple matter. It is difficult to characterize a typical plant and its associated wastes, owing to the many procedures and facets of meat processing operations (Carawan *et al.*, 1979). The contaminant loading of the wastewater discharged from meat processing plants varies seasonally, daily or even on a shift basis (Sroka *et al.*, 2004). The wastewater from the meat industry is extremely difficult to purify due to its specific characteristics, irregular discharge and considerable content of organic, mineral and biogenic matter (Bohdziewicz and Sroka, 2005).

Basic indices of pollution, such as BOD_5 , COD, suspended solids, organic nitrogen and fats are at least several times higher than those of average domestic sewage. This is why such effluents cannot be directly discharged to receiving water or to a municipal sewage system. The pollutants in the meat industry water wastes take the form of suspended solids, colloids and dissolved compounds (Urbaniak and Sakson, 1999). Direct disposal of these liquid and solid abattoir wastes is not permissible, because they are pollution agents; thus, to reduce adverse ecological effects, waste treatment prior to landfill is required (Guerra-Rodriguez *et al.*, 2003). Table 12.2 displays the composition of abattoir wastes in meat industries. Moreover, Figure 12.1 shows a typical process flow diagram for meat processing operations. Russell (1986) reported that effluents from animal slaughter and processing operations contain high concentrations of protein and fat.

In the case of slaughtering pigs, the wastewater consists of the following: water from washing pigs before slaughter; water from washing viscera, internal organs and pork; water from washing floors and equipment; water from washing pig houses and pig farms; water from processing of meat products; and water from cooling workshop and domestic sewage. The meat wastewater is composed of blood, fat and lard, pig hair, bits of meat and bone, pieces of internal organs and viscera, undigested food, urine and excrement as well as germs and bacteria which are hazardous to humans (Jian and Zhang, 1999).

Table 12.2 Characteristics of abattoir wastes; COD, BOD₅, TSS, VSS and total P

COD	BOD ₅	TSS	VSS	Total P	References
7685 ± 646 mg/l	-	1742 ± 116 mg/l	1520 ± 128 mg/l	217 ± 38 mg/l	Cassidy and Belia, 2005
40 300 mg/l	24 900 mg/l	3450 mg/l	2160 mg/l	200 mg/l	Borja <i>et al.</i> , 1995
2000–6200 mg/l	1300–2300 mg/l	850–6300 mg/l	660–5250 mg/l	15–40 mg/l	Caixeta <i>et al.</i> , 2002
5800 mg/l	2200–9800 mg/l	2400–94 700 mg/l	-	-	Fuchs <i>et al.</i> , 2003
4800–12 600 mg/l	-	1900–43 200 mg/l	1720–33 100 mg/l	110–880 mg/l	Sánchez <i>et al.</i> , 1995
3969 mg/l	1730 mg/l	2580 mg/l	1960 mg/l	171 mg/l	Obaja <i>et al.</i> , 2003
3980–7125 mg/l	2035–4200 mg/l	285–2660 mg/l	-	53.9–91.7 mg/l	Aguilar <i>et al.</i> , 2005

Animal slaughtering provides meat and offal, which are by-products. These by-products are subdivided into edible and non-edible materials. By-products constitute nearly 60 to 70% of the slaughtered carcass, of which nearly 40% forms edible and 20% inedible products (Ranganayaki and Srinivasan, 1999). Also, some by-products of sheep slaughter are considered edible in most of the developing countries, but are used as casings for sausages in the developed countries. On average, proteins associated with the meat industry by-products constitute more than one-eighth of the total protein in the lean meat (Webster *et al.*, 1982). Apart from feeds and fertilizers, there is a growing market for protein hydrolysates which may be used as flavor enhancers, functional ingredients or simply as nutritional additives to food of low protein quality. Protein hydrolysate was prepared from pretreated sheep visceral mass (including stomach, large and small intestines) by enzymatic treatment at $43 \pm 1^\circ\text{C}$ (at the *in situ* pH 7.1 ± 0.2 of the visceral mass) using fungal protease (Bhaskar *et al.*, 2007). The enzyme readily solubilized the proteins of the visceral mass as indicated by the degree of hydrolysis (34%) and nitrogen recovery ($>64\%$). Hydrolysis with an enzyme level of 1% (w/w of total solids) at $43 \pm 1^\circ\text{C}$ with a pH around 7.0 for 45 min was found to be the optimum condition. The yield of protein hydrolysate was about 6% (w/w). The amino acid composition of the protein hydrolysate, which was very hygroscopic, was comparable to that of casein.

As regards the cost, Mittal (2006) reported that US butchers are paying upwards of US\$20/barrel or US\$30–40/steer for residual disposal. Total cost to the slaughter industry for beef slaughter residuals alone would be approximately US\$10 million for disposal of 58 000 tons of waste. In general terms, abattoirs and livestock farmers are finding themselves without disposal services or facing high-disposal fees.

Primary treatment

With the increasing costs of pollution abatement and high cost municipal surcharges, food processors are forced to look into alternative methods for pretreatment of wastewater prior to discharge for secondary treatment or other treatment systems (Sistrunk, 1984).

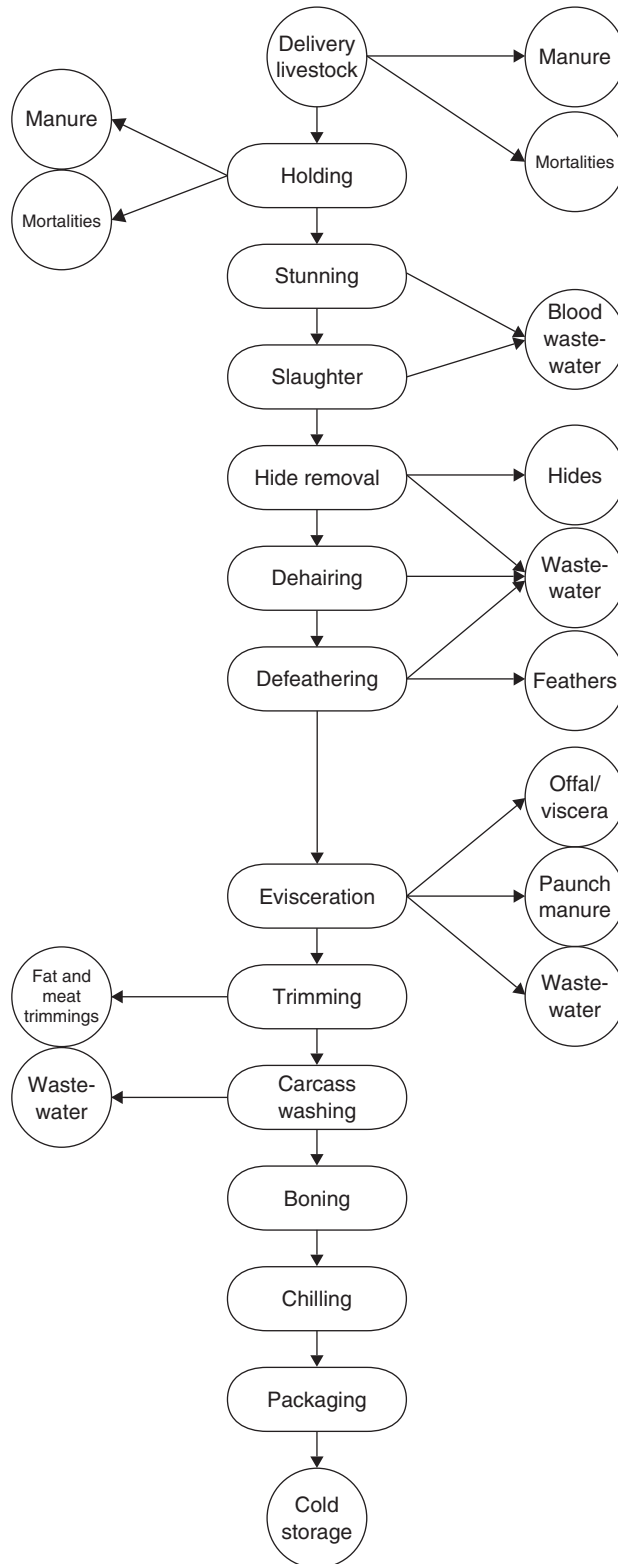

Figure 12.1 General process flow diagram for meat processing operations (adapted from <http://www.gpa.uq.edu.au/CleanProd/Res/facts/FACT7.HTM>)

Physicochemical methods are being increasingly used for the preliminary treatment of wastewater before its biochemical purification. This is due to stricter requirements with regard to the degree of purification of wastewater and the need to remove all organic admixtures before it is discharged (Radoiu *et al.*, 2004).

In wastewater treatment, coagulation/flocculation processes are mainly used for the removal of colloidal material, which causes colors and turbidity. An essential feature of wastewater flocculation is the elimination of suspended solids (SS) and as much of the organic material as possible. To remove SS and organics, a floc forming chemical is needed which can be separated from water by flotation, settling or adsorption (Al-Mutairi *et al.*, 2004). Over the last 20 years, new coagulants, both inorganic and organic, have been used in an attempt to improve the elimination of organic matter and total suspended solids during the treatment of wastes from the agro-food industry and, particularly, those from slaughterhouses (Aguilar *et al.*, 2005).

The rate and effectiveness of the flocculation process employed depended on the composition of the wastewater, its temperature, the rate of mixing and the order in which coagulants and flocculants are introduced into the wastewater. When dissolved in wastewater, flocculants may be in a non-ionized or ionized state. When they are ionized, they are called soluble polyelectrolytes (Radoiu *et al.*, 2004).

In this way, screening, settling and dissolved air flotation (DAF) still remain widely used for the removal of suspended solids and fats, oils and greases from slaughterhouse wastewater. These processes resulted in 75–80% BOD₅ reduction and had the additional advantage of removing large quantities of nitrogen and phosphorus (Johns, 1995). Moreover, the particles present in wastewaters can be removed by coagulation/flocculation processes, the efficiency of which can be studied by comparing the particle size distribution before and after the addition of a coagulant (Lind, 1996; Mejia and Cisneros, 2000; Aguilar *et al.*, 2003).

Dissolved air flotation units can achieve COD reductions ranging from 32% up to 90% and are capable of removing large amounts of nutrients (Mittal, 2006). Similarly, Manjunath *et al.* (2000) reported that DAF units reduce waste strength by about 50%. Furthermore, chemicals such as polymers and flocculants are often mixed prior to the DAF process with the aim of increasing protein clumping and precipitation as well as fat flotation (Mittal, 2006).

Table 12.3 shows the DAF performance on slaughterhouse wastewater. In addition, Table 12.4 displays the influence of various coagulants in removal efficiency of COD, BOD₅ and total suspended solids (TSS) at several conditions of pH and doses of different coagulants aids. As can be seen from Table 12.4, three combinations of compounds: PAX-18, Al₂(SO₄)₃ + PA polyelectrolyte and Fe₂(SO₄)₃ + anionic polyacrylamide appear to be the most effective in COD removal rates, while the results obtained for the other compounds varied with pH.

With the aim of improving the efficiency of a biological treatment process, Grismer *et al.* (2002) conducted studies using alkaline or enzymatic treatments towards hydrolyzing or reducing the size of fat particles in a slaughterhouse wastewater. Particularly, tests were conducted on wastewater samples with 2.5–3.0 g/l of fat particles mixed with the hydrolyzing agents at room temperature for 4 h. The most practical treatment involved a pancreatic lipase which resulted in a reduction in particle size to

Table 12.3 DAF performance on slaughterhouse wastewater

Treatment	%COD removal efficiency	%TSS removal efficiency	References
DAF and chemicals	32–92	70–97	Karpati and Szabo, 1984
DAF at pH 4–4.5	71	78	Travers and Lovett, 1985
DAF and chemicals	38–71	37–63	Mittal, 2006
DAF with air	40	60	Travers and Lovett, 1985

Table 12.4 Removal efficiency of COD, BOD₅ and TSS using different coagulants

Coagulant	%COD removal efficiency	%BOD ₅ removal efficiency	%TSS removal efficiency
Al ₂ (SO ₄) ₃	33.1–87	30–88	31–97
Fe ₂ (SO ₄) ₃	64–78	81–91	43–98
PAX-18	69–80	45–79	57–97
Al ₂ (SO ₄) ₃ + AP	46–87	62–90	86–97
Fe ₂ (SO ₄) ₃ + AP	59–90	62–93	81–98
PAX-18 + AP	69–80	79–90	88–98
Al ₂ (SO ₄) ₃ + AP polyelectrolyte	79.1	86.3	85.4

Adapted from Kargi and Shuler, 1980; Radoiu *et al.*, 2004; Aguilar *et al.*, 2005. AP = anionic polyacrylamide

60% with an attendant increase in free long-chain fatty acids. In this way, Masse *et al.* (2001, 2003) reported that pancreatic lipase, PL-250, proved to be the most efficient in reducing pork fat particle size and increasing free long-chain fatty acid (LCFA) concentration. However, the effectiveness of primary treatment is debatable since pollution is only transferred to another waste (usually solid wastes), which will eventually need to be treated.

Co-composting and co-digestion are two rather new processes that have been adopted because of the fact that most of the wastes to be treated biologically are characterized by a lack of nutrients and porosity. Therefore, a mixture with other complementary wastes stands for a promising approach towards overcoming these problems.

Secondary treatment

Anaerobic digestion

Biological processes were initially used to treat a variety of municipal, industrial and animal wastes (Chan and Hashimoto, 1980). Anaerobic treatment is one of the major biological waste treatment processes in use (Boeing and Larsen, 1982; Madamwar and Mithal, 1986; Landine and Brown, 1988; Desai *et al.*, 1994).

The performance of an anaerobic digestion process is very much dependent on the type and composition of the material to be digested (Murto *et al.*, 2004). Animal wastes produced in confinement operations have the potential for methane production by anaerobic digestion. The waste accumulates in large quantities and is easily collected (Steinsberger and Shih, 1984). In this regard, anaerobic digestion is a promising alternative for the treatment of these materials (DeBaere, 2000; Salminen and Rintala, 2002).

Consequently, the anaerobic digestion process is a promising solution to the problem from both energy conservation and pollution control considerations, since it can reduce the BOD₅ considerably with the production of fuel in the form of methane (Clanton *et al.*, 1985; Yan *et al.*, 1988; Desai and Madamwar, 1994). Besides generating biogas for energy use, the process also kills pathogens and produces stabilized material which can be used as fertilizer in land applications (Salminen and Rintala, 2002).

The main steps in anaerobic digestion are hydrolysis, acidogenesis and methanogenesis (Gujer and Zehner, 1983). It was previously proposed that physical separation of the three phases would lead to greater process efficiency as each may be operated under optimal conditions (Pohland and Ghosh, 1971; Stephenson and Lester, 1986). Moreover, one of the approaches to make anaerobic digestion more efficient and, therefore, more economically attractive, was to optimize the various conditions for enhanced methane production (Desai *et al.*, 1994).

The anaerobic digestion process can be developed over various temperature ranges including mesophilic temperatures of around 35°C and thermophilic temperatures in the range 55–60°C. The conventional anaerobic digesters operate either at mesophilic or thermophilic temperatures (Sánchez *et al.*, 2001).

During anaerobic digestion of meat wastes, the concentration of ammonia-nitrogen rises considerably as protein breakdown occurs. The excess of ammonium can inhibit the decomposition of organic compounds, the production of volatile fatty acids (VFAs) and methanogenesis (Krylova *et al.*, 1997; Kayhanian, 1999; Dong and Tollner, 2003). Furthermore, Callaghan *et al.* (1999) noted that as ammoniacal nitrogen concentration in the digester increased, the digestion process became unstable and biogas production began to drop. Consequently, ammonium toxicity presents a major problem during the anaerobic treatment of protein-rich wastes (Krylova *et al.*, 1997).

Lipids may also cause problems in anaerobic digestion because of their tendency to form floating scum and accumulated long-chain fatty acids (LCFA) (Angelidaki and Ahring, 1993; Hansen *et al.*, 1998; Salminen and Rintala, 2002). Excessive volatile fatty acids (VFA) accumulation can inhibit methanogenesis, while high hydrogen levels can inhibit propionate- and butyrate-degrading acetogens (Angelidaki *et al.*, 1993; Magbanua *et al.*, 2001). Adsorption, precipitation with divalent ions and entrapment in the flocculent structure of the sludge are the mechanisms responsible for the LCFA accumulation. It was shown that LCFA, provided they are associated with the biomass, could be efficiently mineralized followed by enhanced specific methanogenic activity (SMA) (Pereira *et al.*, 2005).

Several authors investigated the feasibility of treating abattoir wastes by anaerobic digestion. Borja *et al.* (1995) used a laboratory-scale anaerobic down-flow fixed bed reactor, operating at 35°C at input soluble chemical oxygen demand (COD) levels

ranging from 4.7 to 28.7 g/dm³ and volumetric organic loading rates ranging from 2.5 to 25 g COD/dm³/day. An exponential dependency of the organic volumetric loading rate with the soluble COD removal was observed in the range of loadings studied, with variation between 1 and 12 g COD/dm³/day.

Stephenson and Lester (1986) used two continuous stirred tank reactors (CSTR) and four anaerobic fluidized bed reactors (AFBR) to study the treatment of a synthetic meat waste during single and two-stage anaerobic treatment. Two-stage reactors removed up to 85% of influent COD concentrations of 5000 mg/l, whereas the single stage AFBR and CSTR removed 76 and 9%, respectively.

Edström *et al.* (2004) investigated the anaerobic digestion of different mixtures of animal by-products, other slaughterhouse waste (i.e. rumen, stomach and intestinal content), food waste and liquid manure at mesophilic conditions (37°C) both at laboratory and pilot scale. Mixtures with animal by-products representing 19–38% of the total dry matter were digested in continuous-flow stirred tank reactors at laboratory and pilot scale. Stable processes at organic loading rates (OLRs) exceeding 2.5 g of VS/l/day and hydraulic retention times (HRTs) less than 40 days could be obtained with total ammonia nitrogen concentrations (NH₄-N + NH₃-N) in the range of 4.0–5.0 g/l.

Desai *et al.* (1994) used a combination of cattle dung, poultry waste and cheese whey, with the aim of improving anaerobic digestion of abattoir wastes in various conditions. The digesters are initially operated at 40°C with a retention time of 10 days, having a loading rate of 6–10 g of total solids/l of digester per day. Best results in terms of gas production (2.2 l/l of digester per day) and its methane content (62% CH₄) were obtained when the three wastes were used in a ratio of 2:1:3 (w/w) on a dry weight basis, of cattle dung:poultry waste:cheese whey and total solids of 6% (w/v).

Moreover, Salminen and Rintala (2002) studied the effect of hydraulic retention time (HRT) and loading on anaerobic digestion of poultry slaughterhouse wastes, using semi-continuously fed laboratory-scale digesters at 31°C. Anaerobic digestion appeared feasible with a loading of up to 0.8 kg volatile solids (VS)/m per day and an HRT of 50–100 days. The specific methane yield was high, from 0.52 to 0.55 m³/kg VS added. On the contrary, at a different loading, in the range from 1.0 to 2.1 kg VS/m³ per day and a different HRT, in the range from 25 to 13 days, the process was inhibited or overloaded.

Steinsberger and Shih (1984) constructed a poultry waste digester in order to treat the waste from 4000 caged laying hens. The system was operated at 50°C and pH 7.5–8.0. The initiation of methane production was achieved using the indigenous microflora in the poultry waste. At an optimal loading rate (7.5 kg volatile solids/m³ per day), the digester produced biogas (55% methane) at a rate of 4.0 m³/m³ per day.

Caixeta *et al.* (2002) investigated the feasibility of a UASB reactor to treat efficiently the wastewaters from the meat processing industry. The reactor operated continuously throughout 80 days with hydraulic retention times of 14, 18, 22 h. The average production of biogas was 11 l/day for the three experimental runs and the removal of total suspended solids varied from 81% to 86%. Moreover, COD removal varied between 77% and 91%, while BOD₅ removal was 95%.

Nikolaeva *et al.* (2002) reported on the treatment of piggery wastes using an anaerobic fixed bed reactor (AFBR) followed by a zeolite bed filtration (ZBF) at temperatures

Table 12.5 COD removal efficiency versus type of anaerobic reactor

Type of reactor	COD removal %	References
AFBR	73	Nikolaeva <i>et al.</i> , 2002
LAR	82	Montalvo, 1995
UASB	77–91	Caixeta <i>et al.</i> , 2002
MBRs	97	Fuchs <i>et al.</i> , 2003
AFFR	85–95	Del Pozo <i>et al.</i> , 2000
Fluidized bed	85	Borja <i>et al.</i> , 1995
Anaerobic filter	30–85	Tritt, 1992
Anaerobic filter	63–85	Ruiz <i>et al.</i> , 1997
Two-stage UASB	90	Sayed <i>et al.</i> , 1993
Anaerobic baffled reactor	75	Polprasert <i>et al.</i> , 1992
Anaerobic filter	37–77	Viraraghavan and Varadarajan, 1996

from 18 to 32°C. The pilot AFBR operated at two different average organic volumetric loading rates, 5.7 and 24.0 kg COD/m³ per day, which corresponded to flow rates of 25 and 45 m³ per day. As a result, COD and BOD removal efficiencies of 73 and 77%, respectively, were achieved. Moreover, average total suspended and settleable solids removals of 63.0 and 68.1%, respectively, were obtained.

Fuchs *et al.* (2003) used a cross-flow membrane bioreactor to treat wastewater from an animal slaughterhouse with 6–8 g COD/l per day loading rate. COD-removal rate was higher than 90%. Methane yield from the treatment of animal slaughterhouse wastewater was in the range of 0.12–0.32 l/g l COD.

Torkian *et al.* (2003) showed that slaughterhouse wastewater can be satisfactorily treated by means of high-rate anaerobic processes, specifically with the use of a USAB reactor. High SCOD removals of between 75 and 90% at OLRs of 13–30 kg COD/m³ per day and methane ethane yields of 200–280 CH₄/kg SCOD_{removed} were reached.

Table 12.5 provides a comparison of results obtained by means of anaerobic treatment of slaughterhouse wastewater. As can be seen from Table 12.5, the percentage COD removal varies because COD removal efficiency is dependent on the loading rate of reactor filled with abattoir wastes and the type of the reactor. Therefore, anaerobic digestion is an effective process for the treatment of slaughterhouse wastewater and specifically with the use of a membrane bioreactor.

Figure 12.2 displays the CH₄ production during the anaerobic digestion of three different slaughterhouse wastes. In all cases, methane production increased with digestion time. The largest increase was recorded during the anaerobic digestion of piggery wastewater at mesophilic temperature, while methane production was higher in digestion of hog and poultry wastes than in chicken manure and cattle slurry. In view of the results obtained, it can be said that anaerobic digestion is well suited to the treatment of slaughterhouse wastewater because a high degree of COD removal was achieved at a significantly lower cost than comparable aerobic systems and the generated methane-rich gas can be used as a fuel.

In anaerobic digestion, co-digestion is the term used to describe the combined treatment of several wastes with complementary characteristics and is one of the main

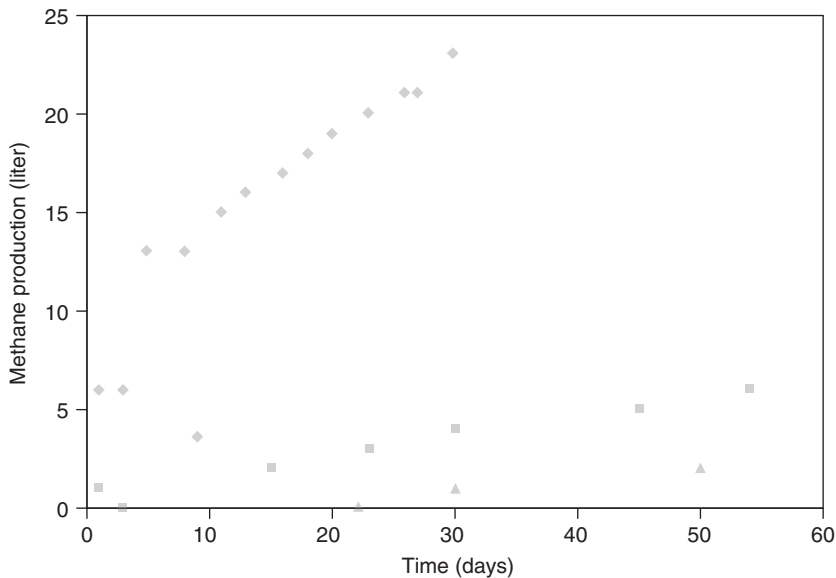

Figure 12.2 Methane production during anaerobic digestion of different slaughterhouse wastes; ◆ piggery wastewater (Sánchez *et al.*, 2001), ■ hog and poultry waste (Magbanoua *et al.*, 2001), ▲ chicken manure and cattle slurry (Callaghan *et al.*, 1999)

advantages of the anaerobic technology. There is abundant literature about the utilization of co-digestion of organic fraction of municipal solid wastes (OFMSW) and agricultural residues, organic solid wastes and sewage sludge (Resch *et al.*, 2006). During the co-digestion with animal fats, methane content in biogas slightly increased from 58 (steady state) to 61%. When animal fats were substituted with vegetable oils, only a slight increase in the VFA was observed (Gomez-Lahoz *et al.*, 2007).

Aerobic digestion

The selection of wastewater treatment process is based on the qualities of effluent and influent volume and type of influent, investment and operating costs and so on (Ruiz *et al.*, 1997; Sirianuntapiboon and Yommee, 2006). The goal of wastewater treatment is to remove the suspended materials and to eliminate the soluble organic contaminants. Biological degradation is the main technology that makes use of adsorption of microbes in activated sludge to oxidize and decompose the solute or suspended protein, fat and lard and other carbohydrates (Spencer and Watson, 1997; Jian and Zhang, 1999). Aerobically treated excrement contains much less soluble organic material than fresh or anaerobically stored excrement and thus its application is less likely to lead to organic pollution of water courses (Owens *et al.*, 1973).

Aeration is a highly effective and simple method for degradation of organic pollutants, including odorants, but its running cost is high. Because it is an exothermic process, the recovery and utilization of heat can help support the treatment cost (Svoboda

and Evans, 1987). Furthermore, aerobic treatments are very effective at reducing odors and pathogens (Skjelhaugen and Donantoni, 1998). These include aerobic lagoon, activated sludge processes—conventional, extended aeration, complete mix, oxidation ditches, sequencing batch reactors (SBRs) and trickling filters and rotating biological contactors (RBCs) (Mittal, 2006). Brenes *et al.* (2000) also reported that, aerobic systems, such as aerated lagoons or activated sludge units, are frequently used to remove the contamination generated by wastewaters from agro-industrial plants.

In most countries, ponds remain the main form of aerobic biological treatment for COD removal from slaughterhouse wastewater, although a wider variety of secondary biological systems has also been used to some extent, including trickling filters and activated-sludge systems (Johns, 1995).

The activated sludge process is a widely used method for treating industrial and domestic wastewater. One of the most common and serious problems in the operation of activated sludge plants is the inability to separate solids from treated effluents in the clarifier (Contreras *et al.*, 2000). In this method, the organic material is converted in the presence of oxygen that is forced into the process water. After primary and secondary sedimentation, the purified water is separated from the remaining sludge. This sludge is rich in protein and poor in fat. Aerobic activated sludge frequently contains high numbers of pathogenic microorganisms and spoilage flora that can cause amino acid breakdown (Stampi *et al.*, 1992; Fransen *et al.*, 1994, 1998).

Sequencing batch reactor (SBR) is a wastewater treatment system based on activated sludge operated on a sequence of fill and draw cycles. SBR treatment for wastewater produces an effluent that is better than that obtained by a secondary treatment and can operate over a wide range of hydraulic and organic flow variations (Mace and Mata-Alvarez, 2002). The unit processes involved in the SBR and conventional activated sludge systems are identical. Aeration and sedimentation are carried out in both systems. However, there is one important difference, in conventional activated sludge plants, the processes are carried out simultaneously in separate tanks, whereas in SBR operations, the processes are carried out sequentially in the same tank (Sirianuntapiboon and Yommee, 2006).

The SBR proved to be a very flexible tool and was particularly suitable for the treatment of piggery wastewater, characterized by high nutrient content and by frequent changes in composition and therefore affecting process conditions. Additionally, SBR performs well with respect to standard wastewater criteria for the removal of organic carbon, nitrogen and phosphate (Obaja *et al.*, 2003). It is widely known that the effect of wastewater treatment in a sequential bioreactor (SBR) greatly depends on the optimum process parameters, i.e. aeration intensity, activated sludge loading, hydraulic retention of wastewater in an aeration chamber and the ratio between stirring time and aeration time (Bohdziewicz and Sroka, 2005).

Several authors studied the aerobic digestion of abattoir waste since the latter is of high polluting potential. Owens *et al.* (1973) have investigated the feasibility of treating pig excrement with two different types of aerobic systems at different loading rates and temperatures. One was operated with floc formation and gravity separation of liquid and suspended solid effluents and a second was operated without floc formation or separation of the effluent into liquid and solid fractions. At a variance of loading rate (g SSg/MLSS per day) between 0.14 and 1.30, the output of suspended solids and chemical oxygen

demands varied between 73 to 109% and 54 to 94%, respectively. In the case of nitrogen balance, nitrogen losses from the treatment systems did not exceed 10% except when the mixed liquor pH was alkaline.

Sirianuntapiboon and Yommee (2006) applied a combination of a moving bio-film (MB), made from the inner tube of used tyres, and a conventional-aerobic-SBR in an attempt to increase the system efficiency and quality of bio-sludge due to good sedimentation non-biodegradability and reusability of the media without any regeneration. As a result, the BOD₅ and COD removal efficiencies of the MB-aerobic-SBR were higher than 95% even when the system was operated with synthetic poultry slaughterhouse wastewater containing 800 mg/l BOD₅ under a very low HRT of 1.5 days (organic loading of 528 ± 50.8 g BOD₅/m³ per day). Furthermore, the BOD₅, TKN and TP removal efficiencies of the MB-aerobic-SBR were about 1–2, 2–3 and 10–12% higher, respectively, than that of the conventional-aerobic-SBR, while total Kjeldahl nitrogen, total phosphorus and suspended solids of the MB-aerobic-SBR under a high organic loading of 528 ± 50.8 g BOD₅/m³ per day were 4.1 ± 1.0 , 1.5 ± 0.80 and 41 ± 2 mg/l, respectively.

Obaja *et al.* (2003) investigated the feasibility of using a sequencing batch reactor as an efficient tool for biological carbon and nutrient removal, capable of achieving effluents with very low nitrogen and phosphorus concentrations from raw and digested pig manure. Nitrogen and phosphorus removal yields amounted to approximately 100% and 98%, respectively, while complete denitrification was obtained when the C/N ratio was equal to or higher than 1.7.

Sroka *et al.* (2004) reported the aerobic digestion of piggery wastewater by a combination of biological treatment in an SBR and post-treatment applying reverse osmosis. They concluded that the application of simple aerobic digestion of piggery wastewater results in COD, total phosphorus and total nitrogen percentages of removal of 90.2–98.9%, 59.9–87.8% and 82.1–95.5%, respectively, while sludge loading varies between 0.05 and 0.75 g/COD_{dry wt.sludge} per day. Furthermore, it was reported that the treatment of piggery wastewater during reverse osmosis, after it was treated biologically applying the activated sludge method, results in COD, total phosphorus and total nitrogen percentages of retention of 85.8%, 97.5% and 90.0%, respectively. Moreover, Cassidy and Belia (2005) studied the formation and performance of granular sludge in an 8 l sequencing batch reactor (SBR) treating a beef processing plant wastewater. Even without optimization of process conditions, removal of COD and P were over 98% and removal of N and VSS were above 97%. Nitrification and denitrification occurred simultaneously during the reaction while aerobic granules formed from flocculating sludge within 4 days by a step-wise reduction in the settle time from 60 to 2 min.

An innovative combination of SBR technology with another reactor was reported by Merzouki *et al.* (2005). The (anaerobic–anoxic) SBR was combined with a fixed-bed reactor operated under aerobic conditions for nitrification with the aim of treating slaughterhouse wastewater. However, the treatment could not be successfully carried out on the raw slaughterhouse wastewater since the process displayed very satisfactory nutrient removal performances after pre-fermentation. The removals of COD, N-NH₄ and P-PO₄ achieved were 99%, 85% and 99%, respectively.

Another interesting combination of anaerobic–aerobic systems was suggested by Del Pozo and Diez (2005). In this case, an integrated anaerobic–aerobic fixed-film

Table 12.6 Aerobic digestion of meat wastes: BOD and COD decrease of organic loading rate versus HRT

Treatment	Organic loading rate	HRT (days)	BOD reduction (%)	COD reduction (%)	References
Fluidized bed biofilm reactor	305–02 mg BOD/l	8.8–30.8	71–93	–	Li <i>et al.</i> , 1986
Activated sludge	400–8000 g BOD/m ³ per day	–	95	–	http://www.epa.nsw.gov.au/mao/abattoirs.htm
Sequencing batch reactor	80–528 g BOD/m ³ per day	1.5–5	≥95	≥95	Sirianuntapiboon and Yomme, 2006
Sequencing batch reactor	0.05–0.75 g COD/g _{dwt} per day		99.6	98.1	Sroka <i>et al.</i> , 1986
Sequencing batch reactor and reverse osmosis	0.15 g COD/g TS per day	12–36	99.5–99.6	96.9–97.3	Bohdziewicz and Sroka, 2005

HRT: hydraulic retention time. Adapted from Sioka *et al.*, 2004

pilot-scale reactor was fed for 166 days with slaughterhouse wastewater. Organic matter removal efficiencies of 93% were obtained for an average organic loading rate of 0.77 kg COD/m³ per day and nitrogen removal efficiencies of 67% were achieved for nitrogen loading rates of 0.084 kg N/m³ per day, while the nitrification process reached an efficiency of 91% for nitrogen loads of 0.15 kg N/m³ per day when the anaerobic–aerobic volume ratio was 2:3 and was limited by dissolved oxygen concentration below 3 mg/l.

Wong *et al.* (2005) investigated the feasibility of upgrading an aerated lagoon system to an SBR with the aim of treating piggery waste. It was reported that a continuous flow, aerated lagoon system could be operated as a sequencing batch reactor with improved performance. As a result, higher than 99% BOD removal efficiency was achieved primarily under a long HRT and sufficient oxygen supply conditions, while the COD removal percentage varied between 96 and 98%.

Table 12.6 summarizes values of organic loading rate, BOD reduction (%) and COD reduction (%), which were observed during aerobic treatment of meat wastes.

Thermal treatments

A series of experiments performed by Conesa *et al.* (2005) aimed at studying the thermal behavior of MBM both in inert (N₂) and reactive atmosphere (air), both by thermogravimetry and in a horizontal laboratory furnace. As a general trend, MBM gives low polychlorinated dibenzo-*p*-dioxins and polychlorinated dibenzofurans (PCDD/F) values, compared with incineration of other wastes. Maximum yield of pollutants is observed at a nominal temperature between 700 and 800°C. In relation to the temperature behavior, the maximum production of PCDD/F was found between 700 and 800°C. Bearing in mind that the reactor is non-isothermal, there is no proof that PCDD/F formation occurs at this temperature. Note that the maximum total yield was obtained at 700°C, but the maximum in terms of I-TEQ was produced in the runs performed at

850°C, due to the dominant presence of HxCDF, HxCDD and PCDD. It is known that the production of products of incomplete combustion is higher at 700–900°C (Fullana *et al.*, 2000). These compounds react in the post-combustion cooling zone to form PCDD/F. At temperatures higher than 950°C the I-TEQ decreases drastically to less than 10 pg I-TEQ/g. It has been reported that under less-than-optimum conditions (such as insufficient oxygen), PCDD/Fs may be formed at temperatures that normally would exceed the threshold temperature of 800°C for PCDD/F formation (Gullet *et al.*, 1990; Walker and Hentley, 1997).

Among the different processes studied, valorization of MBM can be realized with a thermal degradation treatment (incineration or pyrolysis) (McDonnell *et al.*, 2001; Chaala and Roy, 2003; Conesa *et al.*, 2003), as they are a readily flammable fuel (approximately 17 000 kJ/kg) (McDonnell *et al.*, 2001). During high temperature combustion (over 800°C), thermal energy is recovered and proteins such as prions are destroyed (as all organic matter is converted to CO₂, H₂O, etc.) (Riesner, 1997; Dormont, 2002; Taylor, 2002). Co-incineration in cement kilns is the most common way for MBM destruction used in France. They are mixed with cement compounds (calcium, silica, alumina, etc.) and heated to over 1500°C to produce the clinker. As MBM combustion residues mainly arise from bone combustion, they contain a high amount of phosphate and calcium, two major constituents of bone. The resulting ashes were characterized with powder X-ray diffraction (XRD), particle size distribution, specific surface area (BET), scanning electron microscopy (SEM) coupled with energy disperse X-ray analysis (EDX). Elemental analysis revealed the presence of chloride, sodium, potassium, magnesium with high levels of phosphate (56% wt.) and calcium (31% wt.), mainly as a mixture of Ca₁₀(PO₄)₆(OH)₂ and Ca₃(PO₄)₂ phases. The impact of combustion temperature (from 550 to 1000°C) on the constitution of ashes was followed by TGA, XRD and specific surface measurements. A strong decrease in surface area for the ashes was observed, with crystallization of calcium phosphate phases without major changes of chemical composition (Deydier *et al.*, 2005).

A complex gas turbine engine, named IFGT (indirectly fired gas turbine), integrated with a rendering plant was evaluated for poultry industry waste. The rendering plant is composed of two lines: one for meat and the other for feathers. At the end of the process the meat meal has moisture content of 12% and an LHV (for dry matter) of 19.7 MJ/kg, while the oil LHV value is 30 MJ/kg. In the other line, the feathers are pushed into a hydrolyzer where keratin, the main component, is broken into amino acids and then dried (Figure 12.3) in order to decrease moisture from 80 to 10%. The hydrolyzer is a tank where saturated steam is introduced and mixed with feathers. In the feather meal dryer, as in the cooker, heat is supplied with saturated steam and the evaporated moisture is removed by means of a counterflow air stream. The feathers line output consists of a feather meal, whose LHV (for dryer matter) is 18 MJ/kg.

The above described rendering process consists of a combination of thermal utilities and could be integrated into a power generation plant. All the steam required by the rendering process is currently provided by boilers run on natural gas. Nevertheless, it has been pointed out that the rendering makes available an amount of biomass with a defined energy content (15.1 MW based on LHV for the meal only, 21.8 MW considering also the oil). This energy resource can be used as fuel in order to supply the required thermal energy.

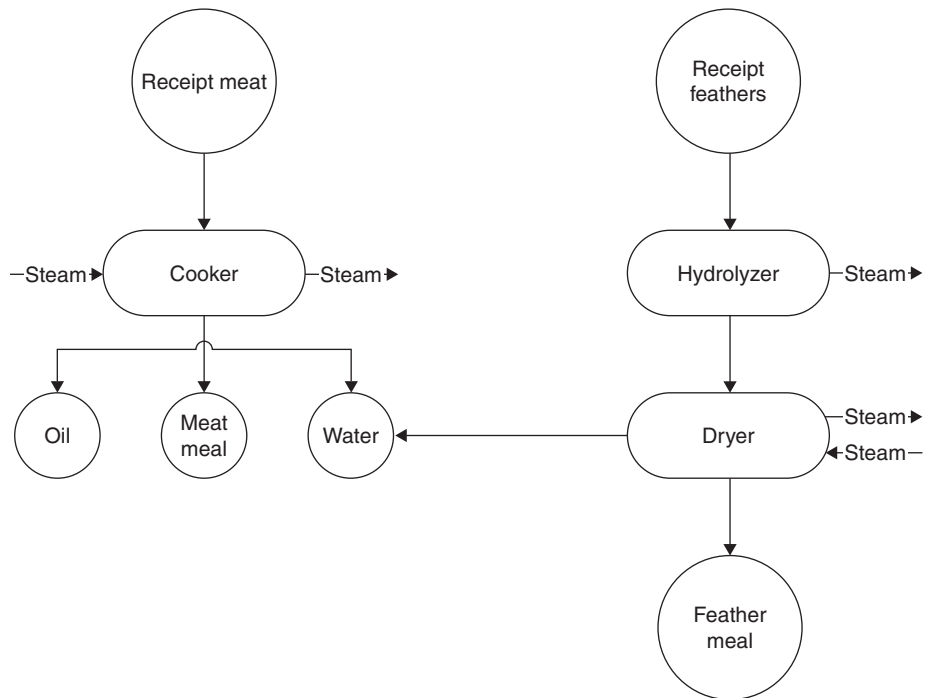

Figure 12.3 Rendering process main lines (adapted from Bianchi *et al.*, 2006)

A CHP (combined heat and power) system is a promising solution in order to meet the need to dispose of the metals, at the same time producing the thermal energy demanded by the process plant and an electric power surplus. In general terms, a gas turbine is a power generator capable of high CHP performance in terms of heat to electric power ratio.

The presented results revealed that energy recovery from poultry industry by-products becomes very attractive if the disposal of these wastes implies a cost to be sustained. In particular, the electric energy production can be a feasible and remunerative investment especially in a deregulated energy market. Among the considered power plants, the IFGT solution presents the best CHP performance and, even if it needs a fossil fuel to be run in efficient way, it can be very competitive in comparison with the examined alternatives. It has been highlighted that the choice of an actual IFGT size driven by economical considerations is extremely sensitive to the current values of the electric energy price and of the cost of natural gas. Depending on these parameters the best size can be a small one (up to 50MW and over, obtained with meals and oil exploitation) if the energy price increases or the natural gas cost decreases (Bianchi *et al.*, 2005).

Composting

Composting is a widely used method for organic waste disposal (Cambardella *et al.*, 2003), while it also has potential as an effective method of treating waste prior to land

application (Imbeah, 1998). It is an aerobic, biological process employing naturally occurring microorganisms to convert biodegradable organic matter into a humus-like product (Lau *et al.*, 1992; Liao *et al.*, 1993; Imbeah, 1998).

Mesophilic and thermophilic microorganisms are involved in composting and their succession is important in the effective management of the process (Beffa *et al.*, 1996; Ishii *et al.*, 2000; Goyal *et al.*, 2005). This process kills pathogens, converts nitrogen from unstable ammonia to stable organic forms, reduces the volume of waste and improves the nature of the waste (Imbeah, 1998).

Poultry farms generate organic manure containing significant quantities of protein and lignocellulosic materials. Direct disposal of these liquid and solid poultry manures is not allowed because they are pollution agents thus, to reduce adverse ecological effects, waste treatment prior to landfilling is required (i.e. composting or anaerobic digestion) (Guerra-Rodriguez *et al.*, 2003). The environmental problems associated with raw manure application could be mitigated with chemical and biological stabilization of soluble nutrients to more stable organic forms by composting before application to agricultural soils (Tiquia and Tam, 2002).

The acceptance of composting, however, depends on how well the operating strategies employed are developed for both product quality and environmental protection (Tiquia and Tam, 2002). In this way, composting provides an inexpensive alternative for disposal of all dead animals, butcher wastes and is an alternative for meat processors who are unable to find someone willing to accept blood and is cost effective (Mittal, 2006; Bonhotal *et al.*, 2002). Moreover, Mittal (2006) reported that on-site composting requires know-how, capital investment, sufficient space and regular maintenance.

Three methods of composting are commonly used: windrows (method used at Illinois State), aerated static piles (windrows with perforated pipe laid within the pile) and bins or aerated chambers. Windrows and aerated static piles are typically used for high volume composting, while bins or aerated chambers are most typical for small volume or home composting (http://www.cast.ilstu.edu/ksmick/363/363lexreport_05.htm).

Several authors investigated the possibility of composting meat wastes. Guerra-Rodriguez *et al.* (2003) examined the co-composting of barley waste with liquid poultry manure. The materials composted reached thermophilic stage temperatures within 4 days, lasting for more than 10 days; thereafter the temperature decreased rapidly to ambient levels. The initial pH value was around 9 for both mixtures and, despite an initial decrease, high values were maintained over the entire co-composting process. Electrical conductivity increased with composting time, while the opposite behavior was recorded for total carbon content. Organic matter loss in the co-composting of barley waste with liquid poultry manure was 35%. The content of $\text{NH}_4\text{-N}$ in the final products was higher than the value advised for mature composts, while the available P and K contents ranged from 0.7 to 2.2% and from 3.4 to 3.8%, respectively.

Imbeah (1998) reviewed composting of piggery waste. He investigated ways in which composting could be used for treating pig manure, pig carcasses and pig litter as well as factors which influence the composting process. In general, he concluded that carcass composting can reduce the cost of carcass disposal, while pig manure, because of its water content, is difficult to compost. Furthermore, carcass composting converted a waste product, containing potential disease-causing organisms, into a

valuable and pathogen-free fertilizer that can be sold for additional revenue or used on the same farm to produce feed grain for the piggery.

Goyal *et al.* (2005) determined changes in organic C, total N, C:N ratio, activities of cellulase, xylanase and protease and microbial population during composting of different meat wastes such as cattle dung and poultry waste. There was a loss in N in poultry waste resulting in an initial increase in the C:N ratio which decreased more, later on, due to decomposition. The activities of cellulase, xylanase and protease reached their maximum values within 30 and 60 days of composting.

Insoluble and hard-to-degrade animal proteins are ubiquitously present throughout animal bodies. Enormous numbers of these proteins are generated in the meat industry in a mixture of bones, organs and hard tissues, finally being converted to industrial wastes, the disposal of which is tremendously difficult (Deydier *et al.*, 2005). Most hard-to-degrade animal proteins are currently disposed of by incineration (Deydier *et al.*, 2005; Paisley and Hostrup-Pedersen, 2005; Haruta *et al.*, 2005). This method, however, has ecological disadvantages in terms of an apparent energy loss and the production of a large amount of carbon dioxide. Thus, an innovative solution to these problems is urgently required.

In terms of quantity, the major hard-to-degrade animal proteins are extracellular matrix proteins (EMPs). A large number of keratins (KRTs) are also generated, mainly from poultry processing and the leather industry (Balint *et al.*, 2005; Barone and Schmidt, 2006). Compared with these two proteins, prion proteins are produced in much smaller amounts but pose more serious problems because they have highly aggregated, hard-to-degrade amyloid isoforms that cause bovine spongiform encephalopathy (BSE). Prion proteins, not fully characterized, have recently attracted general attention due to their serious pathogenicity in meat. Prion proteins display extraordinary resistance to most physical and chemical methods used for the inactivation of conventional pathogens (Taylor, 1991; Taylor *et al.*, 1995; Kuczius *et al.*, 2004).

Thermophilic bacteria are used in the decomposition of these hard-to-degrade animal proteins because, in the elevated temperature range where thermophilic bacteria grow, such proteins tend to gain plasticity, resulting in more susceptibility to protease attack (Suriyama *et al.*, 2005). However, the temperature range (over approximately 80°C) suitable for growing extremely thermophilic bacteria too rapidly induces thermal denaturation of the proteins (Van der Plancken *et al.*, 2003). Moreover, moderately thermophilic bacteria that show an optimum temperature for growing below about 80°C are superior to extremely thermophilic bacteria in terms of the energy cost required to maintain high temperature for bacterial growth.

Uses

Livestock feed and recovery of proteins

The most effective way of reducing the negative environmental impact on the accumulation of waste is the incorporation of the waste into productive processes (Sancho

et al., 2004). The feeding of biological waste to livestock is currently an accepted practice in modern day society and has arisen mainly because of the necessity to reduce costs both in terms of disposal of wastes and in production of meat etc. from livestock (Adel *et al.*, 2002). Insufficiency of feed frequently restricts development of animal production in many developing countries. Therefore, there is a need to find alternative feed resources for animals in order to meet the high demand for animal protein due to the increasing human population (Nambi *et al.*, 1992).

The dry matter of sludge from slaughterhouses consists mainly of protein, fat and other organic matter of animal origin. Studies on the chemical composition of raw flocculated sludge and aerobically activated sludge revealed a protein quality comparable to other feed constituents such as soybean meal or meat meal (Fransen *et al.*, 1994). The wastewaters from the meat, poultry and fish processing industries of the UK have a protein content of up to 1 kg/mm³. This means that about 25 000 tonnes of protein are lost in effluent annually. It is noteworthy that the recovery of protein reduces the biological oxygen demand (BOD) by approximately 75% and the need for conventional pollution control measures such as ferric salt precipitation (Fallows and Wheelock, 1982).

Animal blood is the largest source of potentially edible material. About 100 000 tonnes of blood, which represents approximately 20 000 tonnes of protein are available every year in the UK. Blood has several functional and nutritional attributes which make it a useful ingredient in many food items and markets for hygienically collected and separated blood could be numerous (Fallows and Wheelock, 1982). Spray-dried blood plasma has the greatest potential use in the food industry due to its wide range of desirable functional properties (Gault and Lawrie, 1980).

Although waste blood contained a high concentration of good quality protein, its use for animal feed and human consumption is limited due to consumer esthetic concerns. In fact, its brown color imparts dark hues to food and feed products formulated with blood. Several techniques exist for discoloration of bovine blood, such as treatments with acid acetone hydrogen peroxide, carboxymethyl-cellulose and enzymatic hydrolysis (Gomez-Juarez *et al.*, 1999). Figure 12.4 displays a typical procedure to obtain a protein concentrate from blood.

Meat and bone meal (MBM) was widely recommended and used in animal nutrition as a protein source in place of proteinaceous feeds because of its content of available essential amino acids (EAA) (Cozzi *et al.*, 1995), minerals and vitamin B₁₂ in monogastric nutrition and rumen escape proteins in ruminant nutrition (Piva *et al.*, 2001). The procedure of making meat and bone meal is as follows: safe animal wastes (meat and bones) coming from the slaughterhouse waste are mixed, crushed and cooked together. After the cooking process, tallow is extracted and the remaining residue, known as meat and bone meal (MBM) or animal flour, is sterilized before being safely disposed off (Deydier *et al.*, 2005). However, as a result of the recent bovine spongiform encephalopathy (BSE) crisis in the European beef industry, the use of animal by-products is now strictly controlled. Since November 2000, meat and bone meal (MBM) production can no longer be used to feed cattle but can be incorporated into food for pigs, poultry, fish or animals (Deydier *et al.*, 2005). In EU, there are two regulations (No 1774/2002 and its modification 808/2003) which lay down

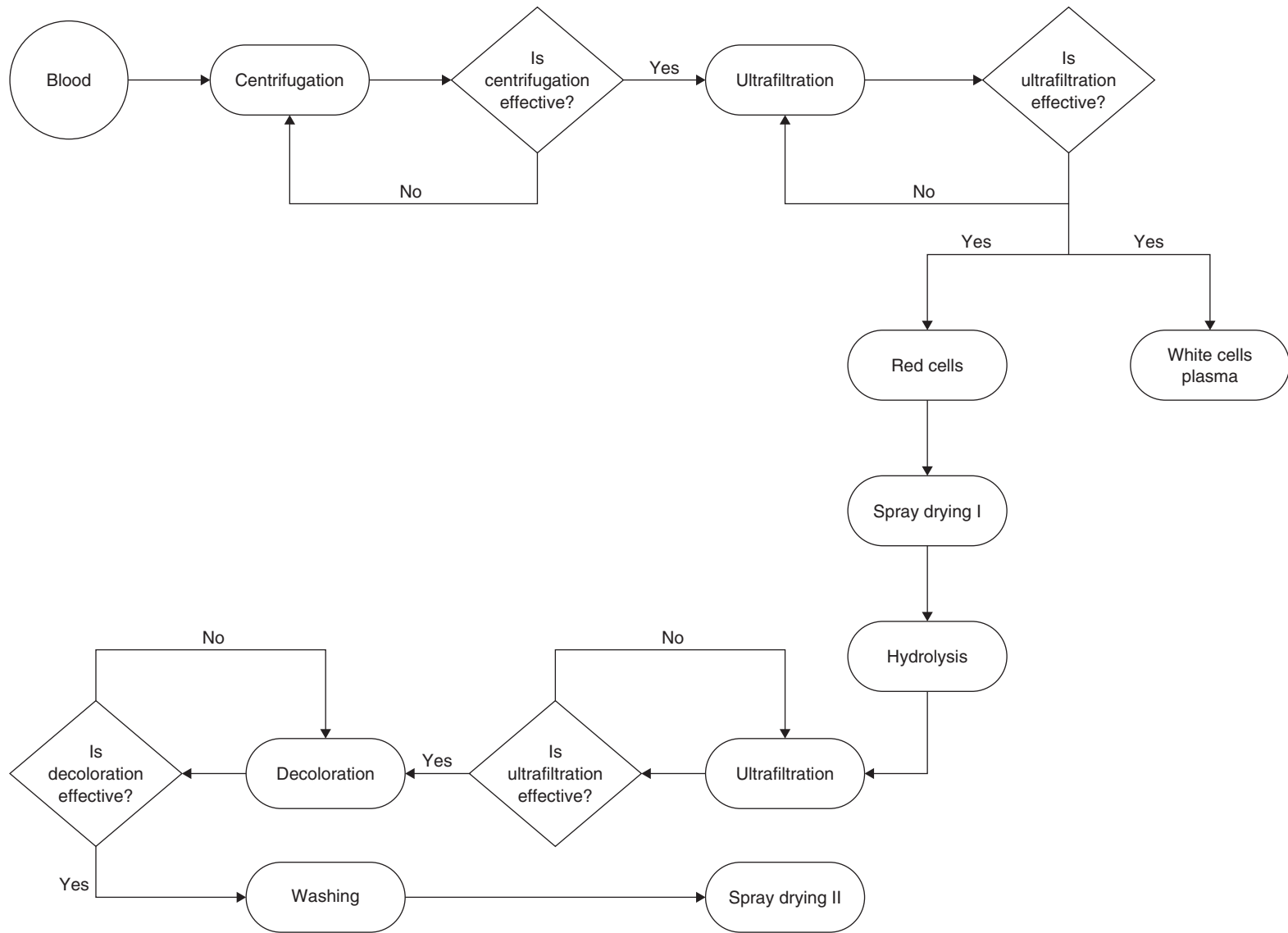

Figure 12.4 Flow diagram for a typical procedure for isolating protein concentrates from blood (Fallows and Wheelock, 1982; Gomez-Juarez *et al.*, 1999)

the health rules concerning animal by-products not intended for human consumption. These regulations describe the conditions of disinfection and the controls to ensure pathogen removal in most of the meat wastes to be biologically degraded.

Obviously, decontamination of the sludge is mandatory when it is to be applied as a feed constituent, to prevent bacterial cycles from occurring in livestock, as well as the spread of human pathogenic zoonoses like *Campylobacter*, *Salmonella* and *Yersinia*, to minimize loss of protein quality by the microbial breakdown of amino acids and the formation of possible toxic metabolites in sludge during storage (Fransen *et al.*, 1994). Food borne illness remains a common and serious problem despite efforts to improve slaughterhouse inspection. It claims millions of victims in the USA every year according to the US Department of Agriculture (USDA).

However, in order to use meat waste fractions as animal feedstuffs, it is necessary to take into account the microbiological factor, the content and the composition of undesirable substances and the current legislation in force (EU Regulations No 1774/2002 and its modification 808/2003). To render the waste fraction samples innocuous, it is sufficient to treat them at 65°C for 20 min. Sancho *et al.* (2004) postulated that, after thermal treatment at a temperature of at least 65°C for 20 min, the nutritional and microbiological parameters remained suitable for possible use as animal feed and that their harmlessness was ensured, with no loss of nutritional characteristics. Furthermore, this heat treatment reduced moisture content, minimized the effects of the anti-nutritional factors, thus considerably improving waste handling and processing (Garcia *et al.*, 2005).

Taylor and Geyer (1979) reported that disease organisms may be transmitted from poultry to other animals through the use of poultry litter as animal feed. There are several diseases affecting poultry that can also affect cattle, pigs and sheep as well as man. Thus, such transmission of disease organisms from poultry to other animals and possibly to man constitutes a hazard to animals and to public health.

Several authors investigated the feasibility of using meat wastes for animal feeding. Fransen *et al.* (1998) postulated that pasteurized activated sludge from a pig slaughterhouse can be effectively fermented into a stable product, suitable for animal feed purposes, with 2.5% (wt/wt) molasses, 0.1% (v/v) formic acid and *L. plantarum* as the inoculum. Al-Masri (2003) carried out experiments with the aim at investigating the changes in the values of feed efficiency (FE), total protein efficiency (TPE) and metabolizable energy efficiency (MEE) of broiler chicks fed diets containing irradiated meat and bone meal during four age periods (14–21, 21–28, 28–35 and 35–42 days). Five experimental diets were similar in composition but different in the irradiation dose (0, 5, 10, 25 or 50 kGy) applied to the meat and bone meal content of each diet. The results revealed that feeding of broiler chicks on irradiated meat and bone meal (5–50 kGy) had no significant effects on feed efficiency (FE), total protein efficiency (TPE), metabolizable energy efficiency (MEE) and body weight gain during the four experimental age periods.

Kargi *et al.* (1980) investigated the feasibility of using by single-stage aerobic continuous process for treating poultry waste in order to produce a single-cell protein useful as feedstuff. Within the range of pH 4.0–8.0, temperature 25–50°C and solids concentrations between 4 and 14% (w/v), optimal conditions were determined for product

Table 12.7 Composition of meat wastes

Composition	Values (%)
Crude protein	15–36
True protein	8.8–12.9
Fiber	8.38–24.6
Dry matter	89.94–97.2
Ash	6.23–40.8
Calcium	0.6–12.5
Phosphorus	0.93–2.8

Adapted from Cunningham, 1976; Connor *et al.*, 1983; Nambi *et al.*, 1992

value maximization raw material cost minimization. The operating conditions of 25°C, pH 7.5, 1.5% solids in the feed and a residence time of 8.1h were found to be the most appropriate conditions in producing a high quality product at minimum cost.

Connor *et al.* (1983) examined two samples of waste activated sludge (WAS) produced with treatment of abattoir effluent in an attempt to use them as sources of nutrients in chicken diets. In contrast to the abovementioned, they reported that the WAS is clearly of limited nutritional value in two areas. First, protein quality was a limiting factor and, secondly, it was poor source of metabolizable energy providing 5.72 and 4.61 MJ/kg dry matter. On the contrary, they postulated that additions of ferric/WAS at all levels protected chickens against the development of riboflavin deficiency symptoms which occurred for both meat meal-based control diets. They concluded that because of their low nutritional value, waste activated sludges are unlikely to gain acceptance as discrete feedstuffs and will have a low market value. Table 12.7 underlines the feasibility of using meat waste with the target to produce feed for animals.

Meat waste (MW), fish waste (FW), fruit and vegetable waste (FVW) were analyzed in an attempt to use them potentially as animal feedstuffs (Garcia *et al.*, 2005). Meat waste comes from butchers, fish waste from fishmongers and fruit and vegetable waste from fruit shops. The different fractions of biodegradable municipal wastes of meat (BMSW) had a high dry matter content (about 60%) for MW the nutritional composition of which is shown in Table 12.8.

The mineral content of the biodegradable waste fractions is presented in Table 12.9. Although macro-minerals such as calcium, potassium, phosphorus, sodium and magnesium were found in all wastes, the highest values were obtained for FW, except for K in FVW. As it was previously discussed, fish waste is a good source not only of protein but also of minerals. FW stood out for its higher calcium content (5.80%) due to its content of fish bones and crustaceans shells. MW contained a high level of calcium (2.18%) which is slightly higher than the values reported for other BMSW (Westendorf *et al.*, 1999). The phosphorus content was lower than the calcium content in all studied fractions. The Ca:P ratio in feedstuffs has special relevance in animal nutrition, because an adequate ratio is a determinant for the optimal absorption and utilization of both minerals (McDonald *et al.*, 1999).

Table 12.3 Nutritional composition of biodegradable municipal wastes of meat (% on a dry matter basis)

Nutrient	Parameter	Meat waste
Dry matter	Mean	59.0 ± 12.3
	SD	12.3
	Min	37.6
	Max	81.1
	No. of samples	36
Crude protein	Mean	24.6 ± 10.3
	SD	10.3
	Min	6.7
	Max	49.3
	No. of samples	36
Ether extract	Mean	69.9 ± 13.7
	SD	13.7
	Min	36.1
	Max	91.6
	No. of samples	36
Crude fiber	Mean	0.6 ± 0.9
	SD	0.9
	Min	0.0
	Max	3.0
	No. of samples	36
Nitrogen free extract	Mean	0.0
	SD	0.0
	Min	0.0
	Max	0.0
	No. of samples	36
Ash	Mean	4.9 ± 4.1
	SD	4.1
	Min	0.5
	Max	19.4
	No. of samples	36

Adapted from Garcia *et al.*, 2005

Energy recovery

The availability of wet biomass as waste from industrial processes and agriculture and farms and the need to meet the environmental standards are the main stimuli towards investigating all options in order to dispose of this waste. The possible treatments usually depend strongly on biomass characteristics, namely water content, density, organic content, heating value, etc. In particular, some of these wastes can be burnt in special plants, using them as an energy supply for different processes (Bianchi *et al.*, 2005). Recently, the thermal recycling of residues as secondary fuel is of increasing interest for power plant operators. Consequently, a variety of coal blends and secondary fuels such as sewage sludge, straw, wood or meat and bone meal (MBM) is combusted (Beck *et al.*, 2004).

Furthermore, as a result of the recent bovine spongiform encephalopathy crisis in the European beef industry, safe animal by-product disposal is currently being

Table 12.9 Mineral content (mean \pm SD) of biodegradable wastes of meat

Element	Meat waste
Ca (%)	1.64 \pm 0.68
P (%)	0.82 \pm 0.24
K (%)	0.30 \pm 0.17
Na (%)	0.28 \pm 0.16
Mg (%)	0.06 \pm 0.02
Fe (ppm)	44 \pm 34
Zn (ppm)	32 \pm 21
Mn (ppm)	Not detected
Cu (ppm)	Not detected
Cr (ppm)	Not detected
Cd (ppm)	Not detected
Pb (ppm)	Not detected
As (ppm)	Not detected
Hg (ppm)	Not detected

Adapted from Garcia *et al.*, 2005. Values in % or mg/kg (ppm) were calculated on a moisture basis of 12%

addressed. One such disposal option is the combustion of by-product material such as meat and bone meal (MBM) in a fluidized bed combustor (FBC) for the purpose of energy recovery (McDonnell *et al.*, 2001). Moreover, Chaala and Roy (2003) postulated that vacuum pyrolysis can be an attractive alternative to incineration and cement kilns in disposal of meat and bone meal (MBM).

Among the different processes studied, valorization of MBM occurred by means of a thermal degradation treatment (incineration or pyrolysis), as it is a highly calorific (approximately 17 000 kJ/kg), easily flammable fuel (Deydier *et al.*, 2005; Conesa *et al.*, 2005). It contains approximately 5% water, 22% ash, 40% carbon, 8% nitrogen, 6% hydrogen, 0.6% sulfur and 0.5% chloride, mainly as common salt. This composition, however, raises concerns about dioxin when incinerating this waste. Furthermore, MBM contains some metals (mainly copper, lead and chromium) known to act as catalysts in the PCDD/F synthesis reactions (Everaert and Baeyens, 2002; Conesa *et al.*, 2005). During high temperature combustion (over 800°C), thermal energy is recovered and proteins such as prions are destroyed (as all organic matter is converted to CO₂, H₂O, etc.) (Deydier *et al.*, 2005). In the EU there are two regulations (No 1774/2002 and its modification 808/2003) which lay down the health rules concerning animal by-products not intended for human consumption. These regulations describe the conditions of disinfection and the controls to ensure pathogen removal in most of the meat wastes to be biologically degraded.

Previous studies documented the usage of poultry litter as an alternative for natural fuel source power generation. As an example of power generation, Fibrowatt built three power plants in the UK, consuming 800 000 t of litter per year to generate approximately 64 MW of electricity (Dávalos *et al.*, 2002).

Svoboda and Evans (1987) investigated the recovery and utilization of heat energy from the aerobic treatment of slurry to remove odor and BOD. An aeration unit with

heat recovery was built for a piggery housing 300 fattening pigs and 100 weaners. The mean value for the extracted heat was 149 kWh/day, the electrical consumption of the aerator was 77 kWh/day and for the pumps, controlling and monitoring equipment 8 kWh/day. Furthermore, the metabolic heat calculated from the carbonaceous oxygen demand, assuming 4 kWh/kg O₂ and nitrogen oxygen demand, assuming 1.2 kWh/kg O₂, averaged 135 kWh/day. The total calculated heat produced was 212 kWh/day, thereby suggesting a heat loss of 63 kWh/day, or 30% of heat output. The model predicted a loss of 52 kWh/day, or 17% less than found.

McDonnell *et al.* (2001) reported the combustion of meat and bone meal (MBM) in a fluidized bed combustor (FBC) aiming at energy recovery. Two short series of combustion tests were conducted on an FBC. In the first series, pellets were fabricated from a mixture of MBM and milled peat at MBM inclusion rates of 0%, 30%, 50%, 70% and 100%. In the second series of tests, the pellets were commercially made. Both sets of pellets were combusted at 880°C. Residence times in the FBC varied from 300 to 100 seconds, while higher compaction pressure increased them as well. Furthermore, MBM was found to be a volatile product (about 65%) and co-firing it with milled peat in a pelleted feed format reduced its volatile intensity.

Dávalos *et al.* (2002) examined the caloric values of poultry litter, which were determined with static bomb calorimetry. These values corresponded to samples treated in different conditions of drying. The caloric value of dry poultry litter (the amount of energy (kJ) released by each unit of combustible mass (kg)) was equivalent to 14 447 kJ/kg, while the wet poultry litter did not burn completely and the mean caloric value for it was 5084 kJ/kg. Furthermore, the concentration of Cl₂ and SO₂ gases were approximately 5.6 and 3.7 mg/kg of poultry burnt, respectively. It is noteworthy that poultry litter with water contents less than 9% can burn without extra fuel. Therefore, these samples were suitable for use as fuel for generation of electrical power.

Chaala and Roy (2003) reported the pyrolysis of meat and bone meal (MBM) in a laboratory reactor. The process generated a combustible gas (15.1 wt %), a high calorific value oil (35.1 wt %), a solid residue rich in minerals (39.1 wt %) and an aqueous phase rich in organics (10.7 wt %). The gas and the aqueous phase can be used to provide heat to the vacuum pyrolysis reactor and the MBM drying unit. The oil can be either used alone or mixed with petroleum products as a fuel in boilers or gas turbines. However, the presence of nitrogenated compounds may cause some environmental problems if the oil is used alone.

Kupusovic and his coworkers (2006) studied the balance of materials and associated costs in a small case slaughterhouse industry before and three months after implementation of CP measures (Table 12.10). It is important to note that at the time of analysis of the results, a recommended blood collection system had not yet been constructed. The values reported in the table were based on results of analysis of water consumption and wastewater discharge bills issued by the water utility, as well as the information on consumption of salt gathered from the company's accounting books. The values are expressed on an annual basis.

In the first three months of project implementation, the amount of water saved was 32% or 45 m³ per month. If the same trend continued throughout the year, it would result in annual financial savings of approximately 317€. The new wastewater analysis

Table 12.10 Balance of raw materials and costs

	Before	After
Water consumption (m ³ /year)	1831	1557
Wastewater load	BOD ₅ = 3520 mg O ₂ /l PE = 362	BOD ₅ = 2052 mg O ₂ /l PE = 240
Water costs (€/year)	2117	1800
Salt consumption costs (€/year)	306	160
Septic tank emptying cost (€/year)	281	143
Wastewater fee (€/year)	232	194
Total cost (€/year)	2936	
Annual savings (€/year)		669
Investments (€/year)		43
Pay back period		Less than one month

Adapted from Kupusovic *et al.*, 2006

carried out after the 3 months of project implementation revealed that BOD and population equivalent measurements were reduced by 32%, while further reduction was expected with continuation of application of all proposed measures. Moreover, the salt consumption was reduced by 1.8 tons bringing additional savings of 146€/year. Total annual savings resulting from the application of selected measures were 669€/year. Based on the results obtained, the project achieved its goals and demonstrated the environmental and economic advantages of CP.

Heavy metal adsorption

The pollution of the environment with toxic metals is a result of many human activities, such as mining and metallurgy, and the effects of these metals on the ecosystems are of large economic and public health significance. Metals are essential minerals for all aerobic and most anaerobic organisms. However, it has been proven that large amounts of heavy metals, such as copper, lead, cadmium, or mercury adversely affect human health (Gavrilesku, 2004) and can be hazardous to livestock (Abdel-Halim *et al.*, 2003).

Recently, increasing interest in the application of materials of biological origin in heavy metals removal from diluted, large volume solutions has been observed. Sorption with materials of biological origin, like meat wastes, has become an alternative to traditional methods of industrial wastewaters treatment, such as precipitation, adsorption, electrochemical recovery, ion exchange, coagulation etc. (Deydier *et al.*, 2003; Chojnacka, 2005). These traditional methods are of high cost and potentially of high risk due to the possibility of the generation of hazardous by-products (Gavrilesku, 2004).

Animal bones consist of 65–70% inorganic substances, mainly calcium hydroxyapatite (Samuel *et al.*, 1985). Deydier *et al.* (2003) reported that calcium hydroxyapatite (CaHA) is the major inorganic constituent of bones and teeth. The chemical composition of calcium hydroxyapatite is Ca₁₀(PO₄)₆(OH)₂. This material removes the metal ions by means of adsorption and ion exchange from the solutions (Samuel

et al., 1985). Furthermore, Cheung *et al.* (2002) postulated that the removal mechanism was reported to be not merely an adsorption effect but a type of ion-exchange reaction between the ions in solution and the calcium ions of the apatite. Therefore, CaHA is a well recognized active compound for the removal of metal ions from wastewaters (Cheung *et al.*, 2002).

Several authors reported the feasibility of animal bones to remove heavy metals. Cheung *et al.* (2001) have used bone char as an adsorbent to remove cadmium ions using a batch absorber. Bone char is a product obtained from the calcinations of bovine bones at high temperatures in the absence of air. Bone char is derived from the carbonization of crushed animal bones by heating them to 500–700°C in an airtight iron retort for 4–6 h. Although the utilization of bone char as an adsorbent has been reported for many years, the use of bone char as an adsorbent for cadmium ion removed has seldom been reported.

Abdel-Halim *et al.* (2003) investigated the adsorption capacity of some natural materials such as animal bone powder for lead. The adsorption process was affected by various parameters such as contact time, pH and lead solution concentration. The lead uptake percentage reached equilibrium state after 15 min for bone powder, while it increased with an increase in pH. Furthermore, the percentage removal of lead by bone powder was 100%.

Cheung *et al.* (2002) studied the sorption rate of copper and zinc ions onto bone char around pH 5 using a batch agitation system. When pH values of solutions were adjusted to pH 4 or below, the X-ray desorption patterns showed the degrees of the crystalline hydroxyapatite in the bone char reducing. Therefore, the sorption process for the metal ions removal from effluent was recommended to be controlled around pH 5 or above to reduce the loss of the sorbent. Furthermore, the constant pore diffusivities for the sorption of copper and zinc ions onto bone char were equivalent to 6.67×10^{-7} and $6.32 \times 10^{-7} \text{ cm}^2/\text{s}$, respectively. Figure 12.5 shows the effect of contact time on uptake percentage of lead and zinc adsorbed by bone chars. An increase in contact time leads to a higher uptake percentage, while the percentage removal of lead and zinc was 100% and 40%, respectively (Cheung *et al.*, 2002; Abdel-Halim *et al.*, 2003).

Chojnacka (2005) reported absorption of Cr (III) ions from aqueous solutions by animal bones. Animal bones were found to be an efficient sorbent with the maximum experimentally determined sorption capacity in the range 29–194 mg/g that depended on pH and temperature. The maximum experimentally determined sorption capacity was obtained at 50°C and pH 5. Furthermore, it was found that sorption capacity increased with increase in Cr (III) concentration, temperature and initial pH of metal solution. Particularly, the uptake of chromium ions by animal bones, with an initial concentration of metal 100 mg/kg and sorbent concentration 1 g/l at 20°C, was 43.6 mg/g. Under these conditions, 40% of Cr³⁺ ions were removed. The removal of Cr (III) varied from 40% up to 98.7% from the solution at the concentration of the sorbent 1 and 15 g/l at initial concentration 200 mg/kg.

Deydier *et al.* (2003) evaluated meat and bone meal (MBM) combustion residues, a natural apatite-rich substance, as a low cost substitute for hydroxy-apatite in lead sequestration from water effluents. The lead uptake by MBM combustion residues involved at least three successive steps: surface complexation of lead, Ca₁₀(PO₄)₆(OH)₂

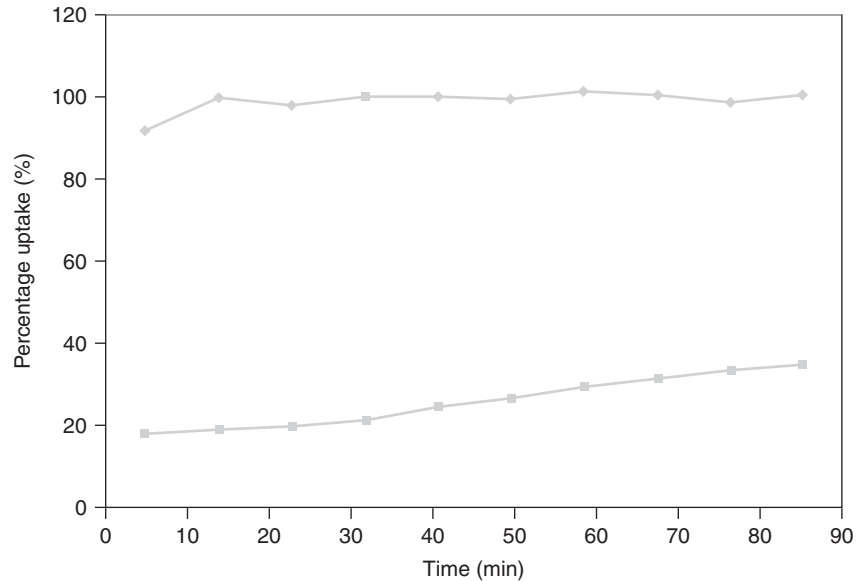

Figure 12.5 Effect of contact time on uptake percent of lead and zinc adsorbed by bone chars (adapted from Cheung *et al.*, 2002; Abdel-Halim *et al.*, 2003)

dissolution followed by precipitation of $\text{Pb}_{10}(\text{PO}_4)_6(\text{OH})_2$ and slow Pb diffusion/substitution of Ca. The first two steps occurred rapidly and a high lead uptake capacity of 275 mg/g ashes was reached in less than 3 h, whereas reaching the total lead immobilization capacity would require more than 10 days. The presence of calcium hydroxyapatite in bone chars was confirmed by means of X-ray diffraction (XRD) analysis. The above results showed that animal bones and MBM combustion residues are calcium hydroxyapatite rich, thus making them a promising adsorption heavy metals substrate for contaminated wastewaters.

References

Scientific references

- Abdel-Halim, S., Shehata, A. and El-Shahat, M. (2003). Removal of lead ions from industrial wastewater by different types of natural materials. *Water Res* **37**, 1678–1683.
- Adel, R., Boushy, E. and Van der Poel, A. (2002). Handbook of poultry feed from waste. Processing and use: review. *Bioresour Technol* **84**, 303.
- Aguilar, M., Saez, J., Llorens, M., Soler, A. and Ortuno, J. (2003). Microscopic observation of particle reduction in slaughterhouse wastewater by coagulation–flocculation using ferric sulphate as coagulant and different coagulant aids. *Water Res* **37**, 2233–2241.
- Aguilar, M., Saez, J., Llorens, M. *et al.* (2005). Improvement of coagulation–flocculation process using anionic polyacrylamide as coagulant aid. *Chemosphere* **58**, 47–56.

- Al-Masri, M. (2003). Productive performance of broiler chicks fed diets containing irradiated meat–bone meal. *Bioresource Technol* **90**, 317–322.
- Al-Mutairi, N., Hamoda, M. and Al-Ghusain, I. (2004). Coagulant selection and sludge conditioning in a slaughterhouse wastewater treatment plant. *Bioresource Technol* **95**, 115–119.
- Andersen, H. and Aalund, O. (1975). Intensive animal production in Denmark: some environmental aspects. *Agricult Environ* **2**, 65–73.
- Angelidaki, I. and Ahring, B. (1993). Thermophilic anaerobic digestion of livestock waste: effect of ammonia. *Appl Microbiol Biotechnol* **38**, 560–564.
- Angelidaki, I., Ellegaard, L. and Ahring, B. (1993). A mathematical model for dynamic simulation of anaerobic digestion of complex substrates: focusing on ammonia inhibition. *Biotechnol Bioengin* **42**, 159–166.
- Arkhipchenko, I., Salkinoja-Salonen, M., Karyakina, J. and Tsitko, I. (2005). Study of three fertilizers produced from farm waste. *Appl Soil Ecol* **30**, 126–132.
- Balint, B., Bagi, Z., Rakhely, G., Perei, K. and Kovacs, K.L. (2005). Utilization of keratin-containing biowaste to produce biohydrogen. *Appl Microbiol Biotechnol* **69**, 404–410.
- Barone, J.R. and Schmidt, W.F. (2006). Effect of formic acid exposure on keratin fiber derived from poultry feather biomass. *Bioresource Technol* **97**, 233–242.
- Beck, J., Brandenstein, J., Unterberger, S. and Hein, K.R.G. (2004). Effects of sewage sludge and meat and bone meal Co-combustion on SCR catalysts. *Applied Catalysis B: Environment* **49**(1), 15–25.
- Beffa, T., Blanc, M., Marilley, L., Fischer, J., Lyon, P. and Arangno, M. (1996). *Taxonomic and metabolic microbial diversity during composting. The science of composting*. Chapman and Hall, London.
- Benka-Coker, M. and Ojioro, O. (1995). Effect of slaughterhouse wastes on the water quality of Ikpoba river, Nigeria. *Bioresource Technol* **52**, 5–12.
- Bhaskar, N., Modi, V.K., Govindaraju, K. and Lalitha, R.G. (2007). Utilization of meat industry by products: protein hydrolysate from sheep visceral mass. *Bioresource Technol* **98**, 388–394.
- Bianchi, M., Cherubini, F., De Pascale, A., Peretto, A. and Elmegaard, B. (2005). Cogeneration from poultry industry wastes: indirectly fired gas turbine application. *Energy* **2**, 1–20.
- Boeing, P. and Larsen, V. (1982). Anaerobic fluidized bed whey treatment. *Biotechnol Bioengin* **24**, 2539–2556.
- Bohdziewicz, J. and Sroka, E. (2005). Integrated system of activated sludge–reverse osmosis in the treatment of the wastewater from the meat industry. *Process Biochem* **40**, 1517–1523.
- Bonhot, J., Telega, L. and Petzen, J. (2002). *Natural rendering: composting livestock mortality and butcher waste*. Cornell Waste Management Institute, New York.
- Borja, R., Banks, C. and Martin, A. (1995). Influence of the organic volumetric loading rate on soluble chemical oxygen demand removal in a down-flow fixed-bed reactor treating abattoir wastewater. *J Chem Technol Biotechnol* **64**, 361–366.
- Borja, R., Banks, C. and Wang, Z. (1995). Effect of organic loading on anaerobic treatment of slaughterhouse wastewater in a fluidised-bed reactor. *Bioresource Technol* **52**, 157–162.
- Brenes, M., Garcia, P., Romero, C. and Garrido, A. (2000). Treatment of green table olive waste waters by an activated-sludge process. *J Chem Technol Biotechnol* **75**, 459–463.

- Caixeta, C., Cammarota, M. and Xavier, A. (2002). Slaughterhouse wastewater treatment: evaluation of a new three-phase separation system in a UASB reactor. *Bioresource Technol* **81**, 61–69.
- Callaghan, F., Wase, D., Thayanithy, K. and Forster, C. (1999). Co-digestion of waste organic solids: batch studies. *Bioresource Technol* **67**, 117–122.
- Cambardella, C., Richard, T. and Russell, A. (2003). Compost mineralization in soil as a function of composting process conditions. *Eur J Soil Biol* **39**, 117–127.
- Carawan, R., Chambers, J. and Zall, R. (1979). *Meat processing water and wastewater management*. North Carolina agricultural extension service. Special Report No AM-18c.
- Cassidy, D. and Belia, E. (2005). Nitrogen and phosphorus removal from an abattoir wastewater in a SBR with aerobic granular sludge. *Water Res* **39**, 4817–4823.
- Chaalal, A. and Roy, C. (2003). Recycling of meat and bone meal animal feed by vacuum pyrolysis. *Environ Sci Technol* **37**, 4517–4522.
- Chan, Y. and Hashimoto, A. (1980). Substrate utilization kinetic model for biological treatment processes. *Biotechnol Bioengin* **22**, 2081–2095.
- Cheung, C., Porter, J. and McKay, G. (2001). Sorption kinetic analysis for the removal of cadmium ions from effluents using bone char. *Water Resources Res* **35**, 605–612.
- Cheung, C., Porter, J. and McKay, G. (2002). Removal of Cu(II) and Zn(II) ions by sorption onto bone char using batch agitation. *Langmuir* **18**, 650–656.
- Chojnacka, K. (2005). Equilibrium and kinetic modelling of chromium(III) sorption by animal bones. *Chemosphere* **59**, 315–320.
- Clanton, C., Goodrich, P., Morris, H. and Backus, B.D. (1985). Anaerobic digestion of cheese whey. In *Proceedings of the Fifth International Symposium on Agricultural Wastes*, pp. 475–482. ASAE, St Joseph.
- Commission of the European Communities. (1990). Council Directive 90/667/EEC. Official journal, No. L 363, 27.12, p. 51.
- Conesa, J., Fullana, A. and Font, R. (2005). Dioxin production during the thermal treatment of meat and bone meal residues. *Chemosphere* **59**, 85–90.
- Conesa, J., Fullana, A. and Font, R. (2003). Thermal decomposition of meat and bone meal. *J Anal Appl Pyrolysis* **70**, 619–630.
- Connor, J., Yule, W., Herbert, S. and Kavanagh, B. (1983). The value of activated sludges derived from abattoir wastes in chicken diets. *Agricult Wastes* **6**, 235–248.
- Contreras, E., Giannuzi, L. and Zaritzky, N. (2000). Growth kinetics of the filamentous microorganism *Sphaerotilus natans* in a model system of a food industry wastewater. *Water Resources Res* **34**, 4455–4463.
- COWI (1999). Internal data. Consulting Engineers and Planners AS, Denmark.
- Cozzi, G., Andrighetto, I. and Berzaghi, P. (1995). *In situ* ruminal disappearance of essential amino acids in protein feedstuffs. *J Dairy Sci* **78**, 161–171.
- Cunningham, F. (1976). Using dehydrated poultry waste in poultry rations – a review. *Agricult Environ* **3**, 69–76.
- Dávalos, J., Victoria Roux, M. and Jiménez, P. (2002). Evaluation of poultry litter as a feasible fuel. *Thermochim Acta* **394**, 261–266.
- DeBaere, L. (2000). Anaerobic digestion of solid waste: state of the art. *Water Sci Technol* **41**, 283–290.
- Del Pozo, R., Diez, V. and Beltran, S. (2000). Anaerobic pre-treatment of slaughterhouse wastewater using fixed-film reactors. *Bioresource Technol* **71**, 143–149.

- Del Pozo, R. and Diez, V. (2005). Integrated anaerobic–aerobic fixed-film reactor for slaughterhouse wastewater treatment. *Water Res* **39**, 1114–1122.
- Desai, M. and Madamwar, D. (1994). Anaerobic digestion of a mixture of cheese whey, poultry waste and cattle dung: a study of the use of adsorbents to improve digester performance. *Environ Pollut* **86**, 337–340.
- Desai, M., Patel, V. and Madamwar, D. (1994). Effect of temperature and retention time on biomethanation of cheese whey poultry waste-cattle dung. *Environ Pollut* **83**, 311–315.
- Deydier, E., Guilet, R. and Sharrock, P. (2003). Beneficial use of meat and bone meal combustion residue: an efficient low cost material to remove lead from aqueous effluent. *J Hazard Mater* **101**, 55–64.
- Deydier, E., Guilet, R., Sarda, S. and Sharrock, P. (2005). Physical and chemical characterisation of crude meat and bone meal combustion residue: ‘waste or raw material?’ *J Hazard Mater* **121**, 141–148.
- Dong, X. and Tollner, E. (2003). Evaluation of Anammox and denitrification during anaerobic digestion of poultry manure. *Bioresource Technol* **86**, 139–145.
- Dormont, D. (2002). Prions, BSE and food. *Int J Food Microbiol* **78**, 181–189.
- Edström, M., Nordberg, A. and Thyselius, L. (2004). Anaerobic treatment of animal byproducts from slaughterhouses at laboratory and pilot scale. *Appl Biochem Biotechnol* **109**, 127–138.
- European Commission. (2003). Integrated pollution prevention and control. Draft reference document on best available technologies in the slaughterhouses and animal by-products industries. Final draft. EC, Brussels (<http://eippcb.jrc.es/pages/BActivities.cfm>)
- Everaert, K. and Baeyens, J. (2002). The formation and emission of dioxins in large scale thermal processes. *Chemosphere* **46**, 439–448.
- Fallows, S. and Wheelock, V. (1982). By products from the U.K. food system 2. The meat industry. *Conservat Recyc* **5**, 173–182.
- Fransen, N., Van den Elzen, A., Urlings, H. and Bijker, P. (1994). Pathogenic micro-organisms in slaughterhouse sludge – a survey. *Int J Food Microbiol* **33**, 245–256.
- Fransen, N., Urlings, H., Bijker, P. and Logtestijn, J. (1998). Fermentation of aerobically slaughterhouse sludge for purposes. *Bioresource Technol* **65**, 145–150.
- Fuchs, W., Binder, H., Mavrias, G. and Braun, R. (2003). Anaerobic treatment of wastewater with high organic content using a stirred tank reactor coupled with a membrane filtration unit. *Water Res* **37**, 902–908.
- Fullana, A., Font, R., Conesa, J.A. and Blasco, P. (2000). Evolution of products in the combustion of scrap tires in a horizontal laboratory scale reactor. *Environ Sci Technol* **34**, 2091–2099.
- García, A., Esteban, M., Marquez, M. and Ramos, P. (2005). Biodegradable municipal solid waste: characterization and potential use as animal feedstuffs. *Waste Manage* **25**, 780–787.
- Gault, N.F.S. and Lawrie, R.A. (1980). Efficiency of protein extraction and recovery from meat industry by-products. *Meat Sci* **4**(3), 167–190.
- Gavrilesku, M. (2004). Removal of heavy metals from the environment by biosorption. *Engin Life Sci* **4**, 219–232.
- Gomez-Juarez, C., Castellanos, R., Ponce-Noyolaa, T., Calderonb, V. and Figueroaa, J. (1999). Protein recovery from slaughterhouse wastes. *Bioresource Technol* **70**, 129–133.

- Gomez-Lahoz, C., Fernández-Giménez, B., Garcia-Herruzo, F., Rodriguez-Maroto, J.M. and Vereda-Alonso, C. (2007). Biomethanization of mixtures of fruits and vegetables solid wastes and sludge from a municipal wastewater treatment plant. *Journal of Environmental Science and Health – Part A Toxic/Hazardous Substances and Environmental Engineering* **42**(4), 481–487.
- Goyal, S., Dhull, S. and Kapoor, K. (2005). Chemical and biological changes during composting of different organic wastes and assessment of compost maturity. *Bioresource Technol* **96**, 1584–1591.
- Grismer, M.E., Ross, C.C., Valentine Jr., G.E., Smith, B.M. and Walsh Jr., J.L. (2002). Food Processing Wastes. *Water Environ Res* **74**(4), 377–384.
- Guerra-Rodríguez, E., M. Vázquez, E. and Díaz-Raviña, M. (2000). Co-composting of barley wastes and solid poultry manure. *Bioresource Technol* **75**, 223–225.
- Guerra-Rodríguez, E., M. Vázquez, E. and Díaz-Raviña, M. (2003). Dynamics of the co-composting of barley waste with liquid poultry manure. *J Sci Food Agricult* **83**, 166–172.
- Gujer, W. and Zehner, A. (1983). Conversion processes in anaerobic digestion. *Water Sci Technol* **15**, 127–167.
- Gullett, B.K., Bruce, K.R. and Beach, L.O. (1990). The effect of metal catalysts on the formation of polychlorinated dibenzo-p-dioxin and polychlorinated dibenzofuran precursors. *Chemosphere* **20**, 1945–1952.
- Hansen, K., Angelidaki, I. and Ahring, B. (1998). Anaerobic digestion of swine manure: inhibition by ammonia. *Water Res* **32**, 5–12.
- Haruta, S., Nakayama, T., Nakamura, K. *et al.* (2005). Microbial diversity in biodegradation and reutilization processes of garbage. *J Biosci Bioengin* **99**, 1–11.
- Imbeah, M. (1998). Composting piggery waste: a review. *Bioresource Technol* **63**, 197–203.
- Ishii, K., Fukui, M. and Takii, S. (2000). Microbial succession during a composting process as evaluated by denaturing gradient gel electrophoresis analysis. *J Appl Microbiol* **89**, 768–777.
- Jian, T. and Zhang, X. (1999). Bioprocessing for slaughterhouse wastewater and its computerized control and supervisory system. *Resources Conservat Recyc* **27**, 145–149.
- Johns, M.R. (1995). Developments in wastewater treatment in the meat processing industry: A review. *Bioresource Technol* **54**, 203–216.
- Kargi, F. and Shuler, M. (1980). An evaluation of various flocculants for the recovery of biomass grown on poultry waste. *Agricult Wastes* **2**, 1–12.
- Kargi, F., Shuler, M., Vashon, R., Seeley, H., Henry, J. and Austic, R. (1980). Continuous aerobic conversion of poultry waste into single-cell protein using a single reactor: kinetic analysis and determination of optimal conditions. *Biotechnol Bioengin* **22**, 1567–1600.
- Karpati, A. and Szabo, L. (1984). Suitable pretreatment of sewage resulting in pollution drop in meat processing. In *Food Industries and the Environment International Syrup* (J. Hollo, ed.), pp. 367–376. Elsevier, Amsterdam.
- Kayhanian, M. (1999). Ammonia inhibition in high-solids biogasification: an overview and practical solutions. *Environ Technol* **20**, 355–365.
- Krylova, N., Khabiboulline, R., Naumova, R. and Nagel, M. (1997). The influence of ammonium and methods for removal during the anaerobic treatment of poultry manure. *J Chem Technol Biotechnol* **70**, 99–105.

- Kuczius, T., Buschmann, A., Zhang, W. *et al.* (2004). Cellular prion protein acquires resistance to proteolytic degradation following copper nion binding. *Biol Chem* **385**, 739–747.
- Kuczius, T., Midzic, S., Silajdzic, I. and Bjelavac, J. (2007). Cleaner production measures in small-scale slaughterhouse industry – case study in Bosnia and Herzegovina. *J Cleaner Product* **15**, 378–383.
- Kupusovic, T., Midzic, S., Silajdzic, I. and Bjelavac, J. (2006). Cleaner production measures in small-scale slaughterhouse industry – case study in Bosnia and Herzegovina. *J Cleaner Product* **15**(4), 378–383.
- Landine, R. and Brown, G. (1988). Anaerobic treatment of dairy waste water. *Proceedings of the 42nd Industrial Waste Conference, Purdue University, Extension Service*, p. 701.
- Lau, A., Lo, K., Liao, P. and Yu, J. (1992). Aeration experiments for swine waste composting. *Bioresource Technol* **41**, 145–152.
- Li, C., Shieh, W., Asce, A., Wu, C. and Huang, J. (1986). Chemical/bio-fluidized bed treatment of slaughterhouse wastewater. *J Environ Engin* **112**, 718–728.
- Liao, P., Vizcarra, A., Chen, A. and Lo, K. (1993). Composting separated solid swine manure. *J Environ Sci Hlth* **28**, 1889–1901.
- Lind, C. (1996). Particle count performance and reduction with polyaluminum hydroxy-chloride coagulants. In *Proceedings of the Annual Conference*, pp. 287–296. American Water Works Association (Management and Regulations), Toronto.
- Mace, S. and Mata-Alvarez, J. (2002). Utilization of SBR technology for wastewater treatment: an overview. *Indust Engin Chem Res* **41**, 5539–5553.
- Madamwar, D. and Mithal, B. (1986). Effect of pectin on anaerobic digestion of cattle dung. *Biotechnol Bioengin* **28**, 624–626.
- Magbanua, B., Thomas, T. and Johnston, P. (2001). Anaerobic codigestion of hog and poultry waste. *Bioresource Technol* **76**, 165–168.
- Manjunath, N., Mehrotra, I. and Mathur, R. (2000). Treatment of wastewater from slaughterhouse by DAF-UASB system. *Water Res* **34**, 1930–1936.
- Masse, L., Kennedy, K. and Chou, S. (2001). Testing of alkaline and enzymatic hydrolysis pretreatments for fat particles in slaughterhouse wastewater. *Bioresource Technol* **77**, 145–155.
- Masse, L., Masse, D. and Kennedy, K. (2003). Effect of hydrolysis pretreatment on fat degradation during anaerobic digestion of slaughterhouse wastewater. *Process Biochem* **38**, 1365–1372.
- McDonald, P., Edwards, R.A., Greenhalgh, J.F.D. and Morgan, C.A. (1999). *Nutrition Animal*, 5th edn, pp. 205–220. Acribia, Zaragoza.
- McDonnell, K., Desmond, J., Leahy, J., Howard-Hildige, R. and Ward, S. (2001). Behaviour of meat and bone meal/peat pellets in a bench scale fluidised bed combustor. *Energy* **26**, 81–90.
- Mejia, A. and Cisneros, B. (2000). Particle size distribution (PSD) obtained in effluents from an advanced primary treatment process using different coagulants. In *Chemical of Water and Wastewater Treatment VI, Proceedings of the Ninth Gothenburg Symposium*, Istanbul, pp. 257–268.
- Merzouki, M., Bernet, N., Delgenes, J. and Benlemlih, M. (2005). Effect of pre-fermentation on denitrifying phosphorus removal in slaughterhouse wastewater. *Bioresource Technol* **96**, 1317–1322.

- Mittal, G. (2006). Treatment of wastewater from abattoirs before land application – a review. *Bioresource Technol* **97**, 1119–1135.
- Montalvo, S. (1995). Treatment of swine wastes by a high-rate modified anaerobic process. *Bioresource Technol* **53**, 207–210.
- Motavalli, J. (1998). The trouble with meat. *Environ Mag* **9**, 28–35.
- Murto, M., Bjornsson, I. and Mattiasson, B. (2004). Impact of food industrial waste on anaerobic co-digestion of sewage sludge and pig manure. *J Environ Manage* **70**, 101–107.
- Nambi, J., Mbugua, P. and Mitaru, B. (1992). Nutritive evaluation of dried poultry excreta as a feed ingredient for broiler chickens. *Anim Feed Sci Technol* **37**, 99–109.
- Nikolaeva, S., Sanchez, S., Borja, R., Travieso, L., Weiland, P. and Milan, Z. (2002). Treatment of piggery waste by anaerobic fixed bed reactor and zeolite bed filter in a tropical climate: a pilot scale study. *Process Biochem* **38**, 405–409.
- Obaja, D., Mace, S., Costa, J., Sans, C. and Mata-Alvarez, J. (2003). Nitrification, denitrification and biological phosphorus removal in piggery wastewater using a sequencing batch reactor. *Bioresource Technol* **87**, 103–111.
- Owens, J., Evans, M., Thacker, F., Hissett, R. and Baines, S. (1973). Aerobic treatment of piggery waste. *Water Res* **7**, 1745–1766.
- Paisley, L.G. and Hostrup-Pedersen, J. (2005). A quantitative assessment of the BSE risk associated with fly ash and slag from the incineration of meat-and-bone meal in a gas-fired power plant in Denmark. *Prev Vet Med* **68**, 263–275.
- Pereira, M., Pires, O., Mota, M. and Alves, M. (2005). Anaerobic biodegradation of oleic and palmitic acids: evidence of mass transfer limitations caused by long chain fatty acid accumulation onto the anaerobic sludge. *Biotechnol Bioengin* **92**, 15–23.
- Piva, G., Moschini, M., Fiorentini, L. and Masoero, F. (2001). Effect of temperature, pressure and alkaline treatments on meat meal quality. *Anim Feed Sci Technol* **89**, 59–68.
- Pohland, F. and Ghosh, S. (1971). Developments in anaerobic stabilization of organic wastes – the two-phase concept. *Environ Technol Lett* **1**, 255–266.
- Polprasert, C., Kemmadamrong, P. and Tran, F. (1992). Anaerobic baffle reactor (ABR) process for treating a slaughterhouse wastewater. *Environ Technol* **13**, 857–865.
- Pontopiddan, O. and Hansen, P. (2001). Cleaner technology in the poultry and cattle slaughtering branch. Project report (renere teknogi pa svine-og kreaturlagterier Resume-rapport). Environmental report No. 9, Danish EPA, 2001 (in Danish). (<http://www.mst.dk/udgiv/publikationer/2000/87-7944-306-0/html/>)
- Radoiu, M., Martina, D., Calinescu, I. and Iovu, H. (2004). Preparation of polyelectrolytes for wastewater treatment. *J Hazard Mater* **106**, 27–37.
- Ramirez, C.A., Patel, M. and Blok, K. (2006). How much energy to process one pound of meat? A comparison of energy use and specific energy consumption in the meat industry of four European countries. *Energy* **31**, 2047–2063.
- Ranganayaki, M.D. and Srinivasan, T.S. (1999). Hygienic processing and utilization of animal by-products. *Souvenir cum Proceedings of National Seminar on Processing of Meat, Poultry and By-products for value addition*, February 24–26, 1999, CFTRI, Mysore, pp. 187–195.
- Resch, C., Grasmug, M., Smeets, W., Braun, R. and Kirchmayr, R. (2006). Optimised anaerobic treatment of house-sorted biodegradable waste and slaughterhouse waste in a high loaded half technical scale digester. *Water Sci Technol* **53**, 213–221.

- Riesner, D. (1997). Prions and their biophysical background. *Biophys Chem* **66**, 259–268.
- Ruiz, I., Veiga, M., Santiago, P. and Blazquez, R. (1997). Treatment of slaughterhouse wastewater in a UASB and an anaerobic filter. *Bioresource Technol* **60**(3), 251–258.
- Russell, J. (1986). Irrigation of primary treated and anaerobically treated meat-processing wastes onto pasture: lysimeter trials. *Agricult Wastes* **18**, 257–268.
- Sachez, E., Milina, Z., Borjab, R., Weiland, P. and Rodriguez, X. (1995). Piggery waste treatment by anaerobic digestion and nutrient removal by ionic exchange. *Resources Conservat Recyc* **15**, 235–244.
- Salminen, E. and Rintala, J. (2002). Anaerobic digestion of organic solid poultry slaughterhouse waste – a review. *Bioresource Technol* **83**, 13–26.
- Samuel, L. and Turek, M.D. (1985). Orthopaedics: Principles and Applications, J.B. Lippincott, 2nd Edn, pp.113 and 136.
- Sánchez, E., Borja, R., Weiland, P., Travieso, L. and Martín, A. (2001). Effect of substrate concentration and temperature on the anaerobic digestion of piggery waste in a tropical climate. *Process Biochem* **37**(5), 483–489.
- Sancho, P., Pinacho, A., Ramos, P. and Tejedor, C. (2004). Microbiological characterization of food residues for animal feeding. *Waste Manage* **24**, 919–926.
- Sayed, S., Van der Spoel, H. and Truijen, G. (1993). A complete treatment of slaughterhouse wastewater combined with sludge stabilisation using two stage high rate UASB Process. *Water Sci Technol* **27**, 83–90.
- Sirianuntapiboon, S. and Yommee, S. (2006). Application of a new type of moving bio-film in aerobic sequencing batch reactor (aerobic-SBR). *J Environ Manage* **78**, 149–156.
- Sistrunk, W. A. (1984). Factors affecting the removal of suspended and dissolved solids in high strength wastewater from vegetable processing. *Publication – Arkansas Water Resources Research Center*, University of Arkansas PUB-108, p. 64.
- Skjelhaugen, O. and Donantoni, L. (1998). Combined aerobic and electrolytic treatment of cattle slurry. *J Agricult Engin Res* **70**, 209–219.
- Spencer, C. and Watson, L. (1997). Optimize wastewater operations. *Hydrocarbon Process* **766**, 77–80.
- Sroka, E., Kamfliskib, W. and Bohdziewicz, J. (2004). Biological treatment of meat industry wastewater. *Desalination* **162**, 85–91.
- Stampi, S., Varoli, O., De Luca, G. and Zanetti, F. (1992). Occurrence, removal and seasonal variation of ‘thermophilic’ campylobacters in a sewage treatment plant in Italy. *Zbl Hyg Umweltmed* **193**, 199–210.
- Steinsberger, S. and Shih, J. (1984). The construction and operation of a low-cost poultry waste digester. *Biotechnol Bioengin* **26**, 537–543.
- Stephenson, T. and Lester, J. (1986). Evaluation of startup and operation of four anaerobic processes treating a synthetic meat waste. *Biotechnol Bioengin* **28**, 372–380.
- Suriyama, S., Hirota, A., Okada, C., Yorita, T., Sato, K. and Ohtsuki, K. (2005). Effect of kiwifruit juice on beef collagen. *J Nutrit Sci Vitaminol* **51**, 27–33.
- Svoboda, I. and Evans, M. (1987). Heat from aeration of piggery slurry. *J Agricult Engin Res* **38**, 183–192.
- Taylor, D. (2002). Inactivation of the BSE agent. *RC Biol* **325**, 75–76.
- Taylor, D.M. (1991). Inactivation of BSE agent. *Dev Biol Stand* **75**, 97–102.

- Taylor, D.M., Woodgate, S.L. and Atkinson, M.J. (1995). Inactivation of the bovine spongiform encephalopathy agent by rendering procedures. *Vet Rec* **137**, 605–610.
- Taylor, J. and Geyer, R. (1979). Regulatory considerations in the use of animal waste as feed ingredients. *J Anim Sci* **48**, 218–222.
- Tiquia, S., Richard, T. and Honeyman, M. (2002). Carbon, nitrogen and mass loss during composting. *Nutrient Cyc Agroecosyst* **62**, 15–24.
- Tiquia, S. and Tam, N. (2002). Characterization and composting of poultry litter in forced-aeration piles. *Process Biochem* **37**, 869–880.
- Torkian, A., Egbali, A. and Hashemian, S. (2003). The effect of organic loading rate on the performance of UASB reactor treating slaughterhouse effluent. *Resources Conservat Recyc* **40**, 1–11.
- Travers, S. and Lovett, D. (1985). Pressure flotation of slaughterhouse wastewaters using carbon dioxide. *Water Res Res* **19**, 1479–1482.
- Tritt, W. (1992). The anaerobic treatment of slaughterhouse wastewater in fixed-bed reactors. *Bioresource Technol* **41**, 201–207.
- Urbaniak, M. and Sakson, G. (1999). Preserving sludge from meat industry waste waters through lactic fermentation. *Process Biochem* **34**, 127–132.
- Van der Plancken, I., Van Remoortere, M., Indrawati, I., Van Loey, A. and Hendrickx, M.E. (2003). Heat-induced changes in the susceptibility of egg white proteins to enzymatic hydrolysis: a kinetic study. *J Agric Food Chem* **51**, 3819–3823.
- Vervoort, R., Radcliffe, D., Cabrera, M. and Latimore, M. (1998). Nutrient losses in surface and subsurface flow from pasture applied poultry litter and composted poultry litter. *Nutrient Cyc Agroecosys* **50**, 287–290.
- Viraraghavan, T. and Varadarajan, R. (1996). Low-temperature kinetics of anaerobic-filter wastewater treatment. *Bioresource Technol* **57**, 165–171.
- Walker, W.J. and Hentley, S.L. (1997). A literature review of formation and release of PCDD/Fs from gas manufacturing: a previously unidentified source? *Chemosphere* **35**, 1409–1422.
- Webster, J.D., Ledward, D.A. and Lawrie, R.A. (1982). Protein hydrolysates from meat industry by-products. *Meat Sci* **7**, 147–157.
- Westendorf, M.L., Schuler, T. and Zirkle, E.W. (1999). Nutritional quality of recycled food plate waste in diets fed to swine. *Profess Anim Sci* **15**(2), 106–111.
- Wong, S., Wu, M. and Choi, C. (1990). Upgrading an aerated lagoon to a sequencing batch reactor for piggery waste treatment. *Biol Wastes*, **34**, 113–122.
- Yan, J., Liao, P. and Lo, K. (1988). Methane production from cheese whey. *Biomass* **17**, 203–211.

e-addresses

http://www.cast.ilstu.edu/ksmick/363/363lexreport_05.htm

<http://www.epa.nsw.gov.au/mao/abattoirs.htm>

<http://www.gpa.uq.edu.au/CleanProd/Res/facts/FACT7.HTM>

Dairy Waste Management: Treatment Methods and Potential Uses of Treated Waste

Ioannis S. Arvanitoyannis and Aikaterini Kassaveti

Introduction	801
Treatment methods	804
Uses	819
Inputs and outputs in dairies	844

Introduction

The dairy industry has grown in most countries of the world because the demand for milk and milk products has steadily risen (Table 13.1). The production of milk per head of cattle has also grown as a result of advancements in veterinary science (Poompavai, 2002). However, total milk consumption (as fluid milk and processed products) per person varies widely from highs in Europe and North America to lows in Asia. Even within regions such as Europe, the custom of milk consumption has varied greatly. Consider for example the high consumption of fluid milk in countries like Ireland and Sweden compared to France and Italy where cheeses have tended to dominate milk consumption (<http://www.foodsci.uoguelph.ca/dairyedu/intro.html>).

The dairy industry is one of the largest sources of industrial effluents in Europe. A typical European dairy generates approximately 500 m³ of waste effluent daily (Wheatley, 1990). The dairy wastewater usually contains proteins, salt, fatty substances, lactose as well as residues of chemicals used during cleaning processes (Thassitou and Arvanitoyannis, 2001). Since the dairy industry produces different products, such as milk, butter, cheese, yogurt, condensed milk, dried milk (milk powder), ice-cream, various types of desserts and cheese (Figure 13.1), the characteristics

Table 13.1 Milk and milk products consumption per capita in various countries in the world

Country	Fluid milk (l)	Cheeses (kg)	Butter (kg)
Romania	163	1.1	0.5
Australia	92.8	11.9	2.7
USA	89.1	14.3	2.0
Russia	87.5	3.5	3.0
New Zealand	87.3	7.0	6.5
Canada	85.6	12.0	3.5
European Union (25 countries)	72.2	12.8	4.6
Ukraine	69.6	2.5	3.0
Brazil	65.9	2.6	0.4
Argentina	53.2	7.9	-
Mexico	40.1	2.0	1.1
Japan	37.8	2.0	0.7
India	32.3	-	2.5

Data 2004, adapted from <http://www.foodsci.uoguelph.ca/dairyedu/intro.html>

of these effluents also vary greatly, depending on the type of system and the methods of operation used (Vidal *et al.*, 2000). However, current awareness of environmental pollution from animal production has triggered research on the interface between animal production and the environment, to assess the ecological sustainability of various animal production systems in an integrated manner (Cederberg and Mattsson, 2000; Cederberg and Dalenius, 2000, 2001; Van Dijk, 2001; Haas *et al.*, 2001; de Boer, 2003; Basset-Mens and Van der Werf, 2005).

Among nations, India is one of the largest and is projected to become the largest producer of milk and dairy products in the world. With annual milk production grossing 85 million tonnes in the year 2002 and growing at the rate of 2.8% per annum (DAH&D, 2003), India is also by far the largest producer of dairy-based wastewaters.

During the last century, environmental problems were often considered local problems due to the impact from a certain product. However, today it becomes more obvious that the problems are much more complex and related to all the phases in a products life cycle, from extraction of material to waste or deposition of the used product (Berkhout and Smith, 1999). The dairy industry is one example of a factory characterized by the association of different production systems such as agriculture, livestock, dairy farming, dairy packaging and product distribution. These systems are closely intertwined, since the final product quality is highly dependent on the appropriate combination between the systems reported (Hospido *et al.*, 2003).

Aerobic treatment processes are commonly used together with anaerobic processes for dairy wastewater treatment, in order to achieve the effluent discharge limits for agro-industry wastewaters (Demirel *et al.*, 2005). On the other hand, the physical/chemical methods that have proven to be successful are coagulation/flocculation (Feofanov and Litmanova, 2001), nanofiltration (NF) and reverse osmosis (RO) membranes (Turan, 2004) and membrane bioreactor (MBR) systems (Bae *et al.*, 2003).

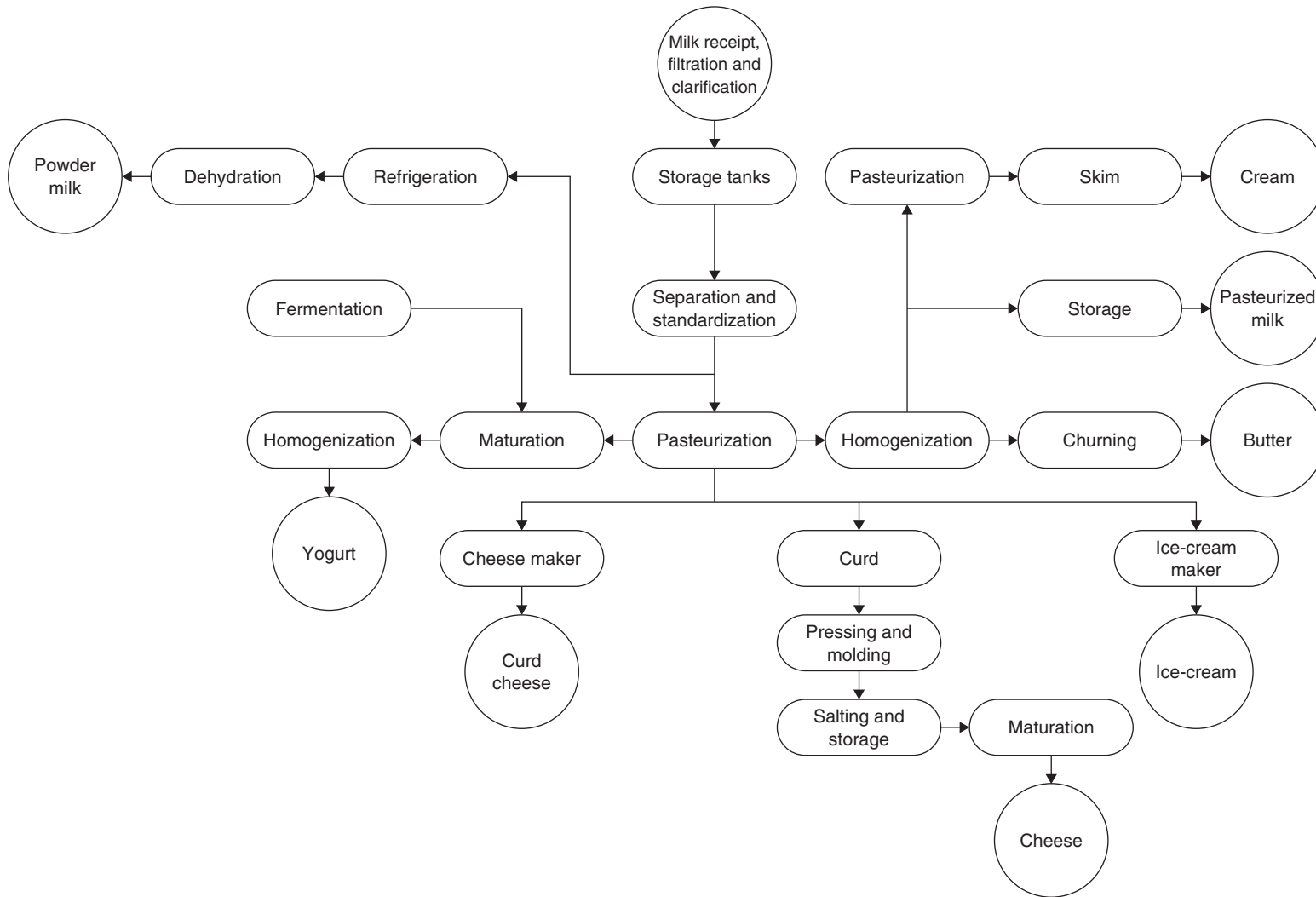

Figure 13.1 Flow diagram of various processes occurring at a typical milk plant (http://www.agrifood-forum.net/publications/guide/d_chp2.pdf; <http://www.fao.org.wairdocs/LEAD/X6114E/x6114e06.htm>; <http://www.edibon.com/products/catalogues/en/systems/pilotplants/LE00.pdf>)

Treatment methods

Dairy wastewater is characterized by the high biological oxygen demand (BOD) and chemical oxygen demand (COD) contents, high levels of dissolved or suspended solids including fats, oils and grease, nutrients such as ammonia or minerals and phosphates and therefore require proper attention before disposal (Sarkar *et al.*, 2006). The processes used nowadays for dairy waste treatment are the following: aerobic treatment, anaerobic treatment, membrane treatment, constructed wetlands, coagulation/electrocoagulation/flocculation/precipitation, bioremediation and miscellaneous treatment methods.

Aerobic treatment

Conventional treatment of dairy wastewater involves aerobic processes, since fats, lactose and proteins are all easily degraded by bacterial populations (Samkutty *et al.*, 1996). Aerobic treatment is an effective alternative for removing odor. Aerobic treatment consumes large quantities of energy and has higher operating and maintenance costs. However, aerobic treatment has lower capital costs than anaerobic digestion and it is less effective in recovering nutrients than anaerobic digestion (<http://www.makinganergy.com/Dairy%20Waste%20Handbook.pdf>).

Two different reactor systems, thermostated at 30°C, were used for aerobic purification of dairy wastewater. The first system (system I) was a single reactor with a working volume of 80 l, while the second one (system II) was a three-stage reactor cascade with a total working volume of 30 l. The minimum operation time for system I was 30 days and, for system II, 50 days. An overload of system I was recorded when the load was higher than 0.741 kg/m³ COD/day, while the system efficiencies were higher than 96.8% and pH values were stabilized. In system II, treatment efficiencies were higher than 98.5% and total chemical oxygen demand (TCOD) and soluble chemical oxygen demand (SCOD) were reduced up to 50 and 70%, respectively. In both systems, minimum organic matter removal was 82%, when loads were lower than 1 kg/m³ COD/day (Carta-Escobar *et al.*, 2004).

Anaerobic treatment

Over the past 25 years, anaerobic digestion processes have been developed and applied to a wide array of industrial and agricultural wastes (<http://www.makinganergy.com/Dairy%20Waste%20Handbook.pdf>). Anaerobic digestion has become an option for sustainable treatment of livestock manure, converting it to biogas and effluent. Digested effluent from anaerobic digestion of livestock manure usually contains high strength ammonium nitrogen (NH₄-N) and persistent organic substances. The components of digested effluent were applied as fertilizer for nutrient recycling back to agricultural fields (Salminen *et al.*, 2001; Umetsu *et al.*, 2002).

Dairy wastewater was treated in upflow anaerobic sludge blanket (UASB) reactors by Ramasamy *et al.* (2004). Two types of UASB reactors were used, anaerobic sludge

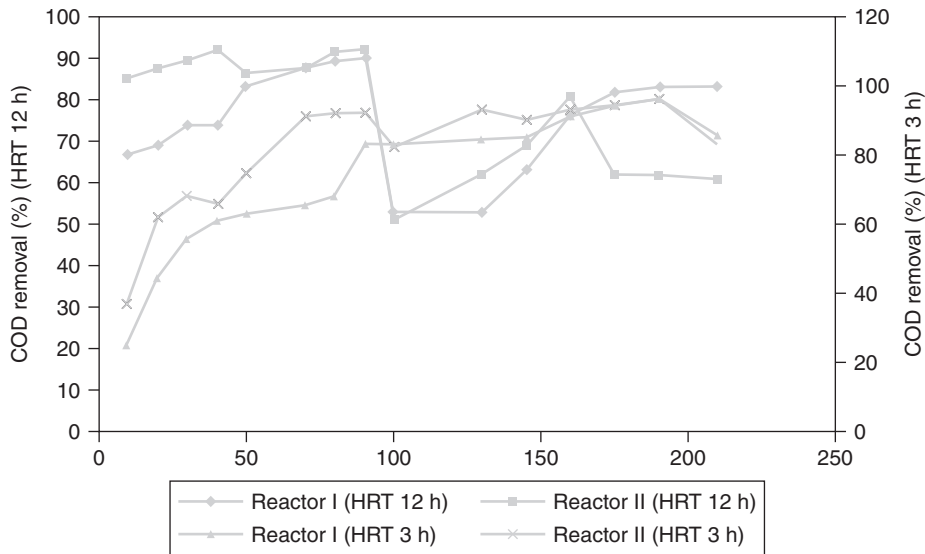

Figure 13.2 COD reduction (%) of synthetic dairy waste treated in two types of UASB reactors (reactors I and II) at two different hydraulic retention times (HRTs) (3 and 12 h) (adapted from Ramasamy *et al.*, 2004)

granules from digested cow dung slurry (DCDS) (reactor I) and granules obtained from the reactors treating sugar industry wastewaters (reactor II) and operated at hydraulic retention times (HRT) of 3 and 12 h and on COD loading rates 2.4–13.5 kg/m³ of digester volume/day. The results indicated that 95.6 and 96.3% maximum COD reduction occurred at HRT of 3 h in reactors I and II, respectively. When the HRT was 12 h, the COD reduction was 90 and 92% in reactors I and II, respectively (Figure 13.2). In both reactors, the maximum, second best and the third best COD reduction was reported at loading rates of 10.8, 8.6 and 7.2 kg/m³/day, respectively, whereas at loading rates higher of 10.8 kg/m³/day the reactors' performance dropped. Better biodegradation of the waste was reported in the first few months of both reactors' operation.

A high-rate anaerobic reactor was developed for treating dairy effluent without fat removal pretreatment. After 400 days of reactor operation, 90% of COD was removed at an organic loading rate of 10 COD/m³/day, while COD recovery as methane was close to 100% (0.371 CH₄/g COD removed). Furthermore, scum accumulation and degradation were observed before stable methanation, whereas complete degradation of scum was recorded when the reactor was unfed (starvation tests). The nature of produced scum changed from hydrophobic (fat) to hydrophilic. On the other hand, loss of enzyme activity was reported during starvation tests of 1–2 weeks, as solids solubilization activity was lost and scum accumulation and degradation occurred. The microbial sludge obtained after starvation tests was in the form of irregular granules and did not require selection pressures caused by washout of poor settling flocs (Haridas *et al.*, 2005).

The anaerobic on-site treatment of synthetic black water (BW) (tap water, toilet paper and primary sludge from a municipal wastewater treatment plant) and dairy parlor wastewater (DPWW) in UASB-septic tanks at low temperatures (10–20°C) for 398 days was

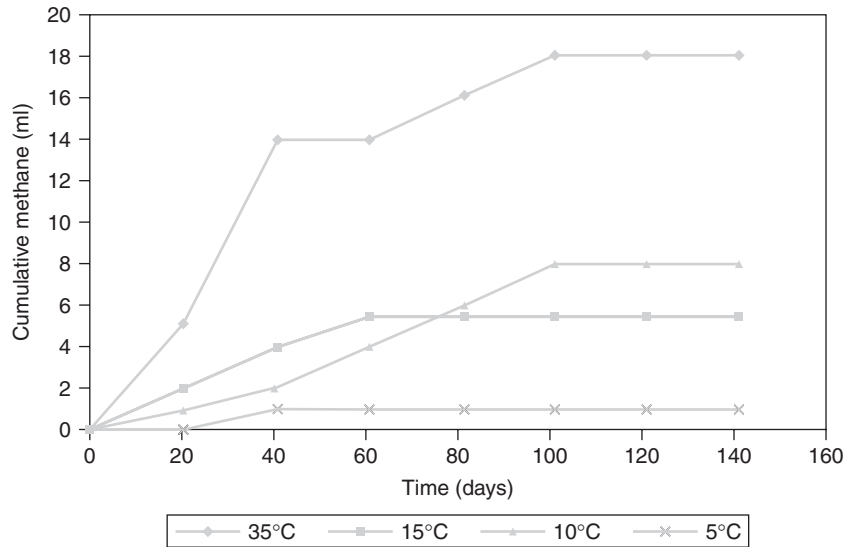

Figure 13.3 Cumulative methane production of sludge from dairy parlor wastewater at various temperatures (adapted from Ferchichi *et al.*, 2005)

investigated by Luostarinen and Rintala (2005). The results indicated 80% and 90% total chemical oxygen demand (TCOD) removal for BW and DPWW, respectively, while above 90% total suspended solids (TSS) removal for both wastewaters was recorded. Furthermore, dissolved COD (DCOD) and BOD₇ removal was approximately 70% and 93%, respectively, for both wastewaters. In both sludges, cumulative methane production was highest at 35°C and decreased with decreasing temperature (Figure 13.3). A single-phased reactor for BW and a two-phased system for DPWW treatment were proven to be sufficient for good COD and solids removals. BW nutrient removal was high, as nutrients were attached to TSS and removed with solids, while DPWW nutrient removal was considerably low. Conclusively, the UASB-septic tank was found efficient for pretreatment of BW and DPWW at low temperatures (Luostarinen and Rintala, 2005).

Three parallel two-stage anaerobic sequencing batch reactor (ASBR) systems (I, II and III), each consisting of two ASBR in series, were operated for dairy wastewater treatment. Two thermophilic (55°C)–mesophilic (35°C) ASBR systems (systems II and III) with 1:4 and 1:2 volume ratios, respectively, and one mesophilic (35°C)–mesophilic (35°C) ASBR system with 1:4 volume ratio were fed with dairy manure and run at two hydraulic retention times (HRTs) (3 and 6 days) and five volatile solids (VS) loading rates (2, 3, 4, 6 and 8 g/l/day). A high solid retention time (SRT) of 13–18 days was applied at both HRTs for all three systems, whereas at HRT of 3 days and at VS loading rates of 6 g/l/day all systems performance deteriorated. At systems operation at HRT of 3 days, the ideal VS loading rates were 2–4 g/l/day. Furthermore, VS removal ranged from 26.1 to 44.2% and specific methane production from 0.2 to 1.6 l/l/day for the three systems. The produced biogas contained 62–66% CH₄ and 28–31% CO₂. An increase up to 37% in NH₃-N in treated wastewater was observed, while the systems with thermophilic reactors were found to be highly effective in destroying the total coliforms (Dugba and Zhang, 1999).

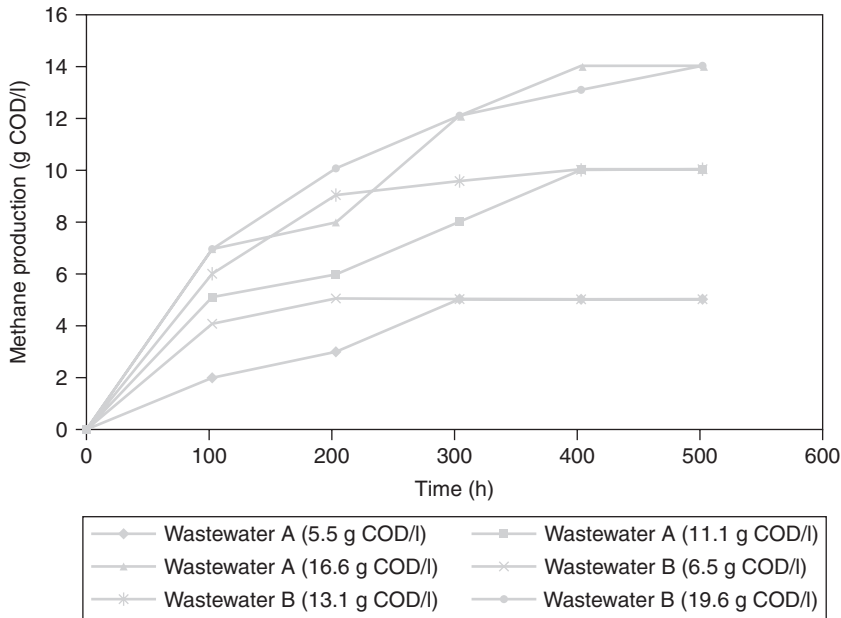

Figure 13.4 Methane production from different effluents (g COD/l) (adapted from Vidal *et al.*, 2000)

Vidal *et al.* (2000) examined the potential effects of fat and protein content on the anaerobic biodegradability of dairy wastewater. Two types of wastewater compositions with total COD 0.4–20 g/l were used for anaerobic biodegradability batch assays, the first obtained by dissolving full cream milk powder (25.4% proteins, 38.9% sugars and 26.0% fats – wastewater A) and the second recovered from skimmed milk powder (33.9% protein, 52.1% sugars and 0.9% fat – wastewater B). At lower concentrations (1–5 g COD/l) biodegradability and methanization were greater in fat-rich wastewater (wastewater A). At higher concentrations (5–20 g COD/l) the biodegradability of wastewater A varied from 98 to 99%, while wastewater B declined from 97.5% down to 86%. Methane production in wastewater B increased linearly with COD increase, in comparison to wastewater A where methane production rate increased only at low COD (<5 g/l) and not at higher concentrations (>6 g COD/l) (Figure 13.4). Furthermore, total volatile fatty acids (VFA) accumulation was observed at higher COD concentrations (5–20 g COD/l), and free ammonia concentration was high (60 mg/l) in wastewater B at high COD values (20 g/l).

Five laboratory-scale mesophilic UASB reactors were fed with dairy wastewater and operated with different intermittent cycle lengths, from 24 to 144 h, and loads between 2.5 and 29.0 g COD/l/day. For each cycle there was a feed and feedless period, which had the same duration (i.e. half the cycle length). The amount of methane produced in the feedless periods was significantly higher compared to the total cycle production and ranged from 22 to 36% of the total methane produced in the whole cycle. Furthermore, COD removal varied between 96 and 98% for all reactors. The higher conversion of removed COD to methane rose from 59 to 85% and was

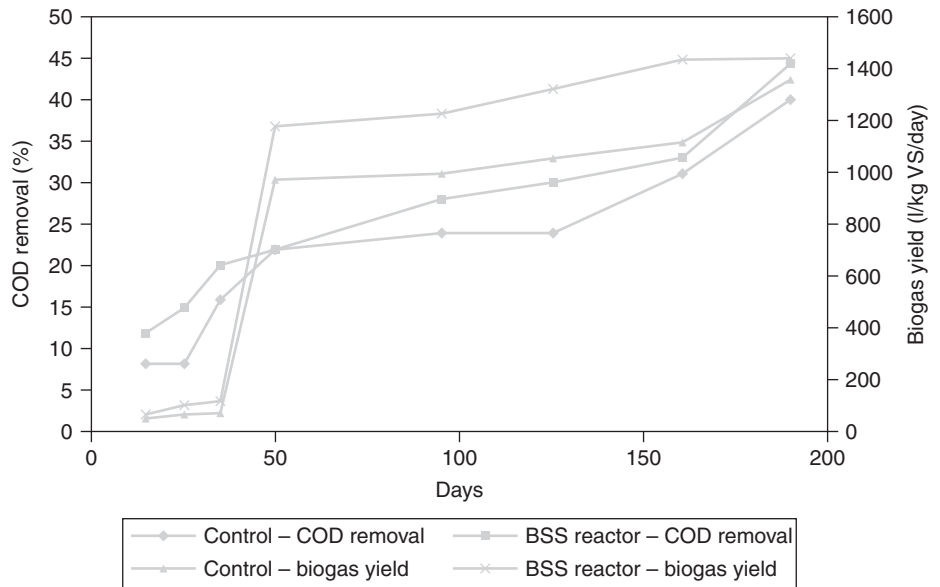

Figure 13.5 Comparison of start-up performance between conventional and BSS-ST reactors regarding COD removal and biogas production (adapted from Ramasamy and Abbasi, 2000; Arvanitoyannis and Giakoundis, 2005)

reported for the 96 h cycle (48 h feed and 48 h feedless period), while this cycle was considered as the optimum one for the treatment of dairy effluents in intermittent UASB reactors (Nadais *et al.*, 2005).

Ramasamy and Abbasi (2000) tried to upgrade the performance of a continuously-stirred tank reactor (CSTR) by incorporating a biofilm support system (BSS). Mixed liquor (synthetic dairy waste, fresh cow-dung slurry, digested cow-dung slurry), which was then replaced with exclusive dairy waste, was used as an initial feed in the reactor with HRT of 15 days. As soon as the feeding of the reactor began, the biogas production also started in both the normal (served as control in their experiments) and BSS reactor. COD and pH reduction of the effluent was found to be low, but when dairy waste was the only feed composition substrate, biogas yield and pH increased. A greater COD reduction was also reported in the BSS reactors than in the conventional ones. Volatile solids (VS) decline was found to be 60% in the BSS reactors and only 40% in the control when the HRT was reduced to 10 days. The biogas released by both reactors varied from 56 to 58% (Figure 13.5).

Membrane treatment

With the advent of membrane technology and significant improvements in efficiency and cost-effectiveness, the competitiveness of recycling dairy wastewater over discharge has greatly increased (Sarkar *et al.*, 2006). Several membrane operations have been proposed for the treatment of dairy effluents: one-stage operations like ultrafiltration (UF) (Blanchard, 1991), nanofiltration (NF) (Koyuncu *et al.*, 2000), reverse osmosis (RO)

(Delbeke, 1981), or two-stage operations like UF + RO (Argellier and Pannuzzo, 1999), NF + NF (Mavrov *et al.*, 2001) and RO + RO (Koyuncu *et al.*, 2000).

Different nanofiltration (NF) and reverse osmosis (RO) membranes for dairy effluent treatment by dead-end filtration were investigated by Balannec *et al.* (2005). Skimmed milk diluted with water (dilution 1/3) (COD \approx 36 g O₂/l) was concentrated to 1/1 milk (volume reduction factor, VRF 3) using nine NF and RO membranes at 25°C, pressure 1.5 MPa (for NF membranes) and 2.5 MPa (for RO membranes), and stirring velocity 100 rpm. High COD, lactose and citrate, bound to Ca⁺, Mg⁺ and micellar casein, removal up to 98.9–99.8%, 98.2–99.8%, and above 99.9%, respectively was observed in the permeate at different membranes and feed concentration. Conductivity rejection to NF and RO membranes was 33–80% and around 96%, respectively, thus showing that treated water cannot be used as a boiler feed water. In NF membranes, divalent cation rejection was above 90%, while negative rejection of Cl⁻ (-26 to -80%) at VRF 3 was recorded. At VRF 3, COD of permeate was not suitable for human consumption (total organic carbon, TOC < 2 mg/l), even though RO permeate can be released as waste.

By-products from ovine cheese manufacture (ovine cheese whey and deproteinized whey) were submitted to two treatments: conventional ultrafiltration (UF) (Treatment I) and thermocalcic precipitation–microfiltration (TP/MF) using two MF membranes (0.65 and 0.20 mm pore size) followed by UF and diafiltration (UF/DF) (Treatment II) (Figure 13.6). The clarification of ovine cheese by-products by TP/MF improved posterior UF treatments significantly. At 0.65 mm pore size of MF membranes, the clarification was more effective and, as well as the obtained product, had high protein content and can be used in the food industry. At 0.20 mm pore size of MF membranes, poor flux performance and high degree of protein retention were reported, thus indicating that MF membranes with pore size 0.65 mm stand for the ideal choice for clarification of ovine cheese by-products (Pereira *et al.*, 2002).

A hollow fiber membrane bioreactor was operated for enzymatic lactose hydrolysis in skimmed milk by Novalin *et al.* (2005). Skimmed milk was pumped through the hollow fiber module and, before enzymatic conversion, was passed over a heat exchanger, a manometer and a thermometer. At the end of the module, the lactose-hydrolyzed product was collected. The enzyme (β -galactosidase) was pumped in a closed circulation and due to the microbiological growth a UV irradiation module and a sterile filtration unit were included in the enzyme circulation. Lactose conversion in skimmed milk rate decreased from 92.48% at flow rate of 5.04 l/h to 78.11% at 9.9 l/h, at enzyme activity of 120 U/ml and a temperature of 23 \pm 2°C in a hollow fiber reactor with a membrane area of 4.9 m².

The use of a ceramic microfiltration (MF) membrane for the fractionation of regular and whey buttermilk, using two different filtration modes, volumetric concentration (VC) and diafiltration (DF), was studied by Morin *et al.* (2006). The experiment was carried out at low temperature (8–10°C) at a transmembrane pressure of 80–95 kPa. The DF process included a significant decrease in protein transmission through the membrane for regular and whey buttermilk (19.5% and 25%, respectively), in comparison to the VC process where protein transmission also decreased for whey buttermilk (33.0%). In the DF process, a decline in ash transmission for regular buttermilk (65.5%) and an increase in phospholipids transmission for regular

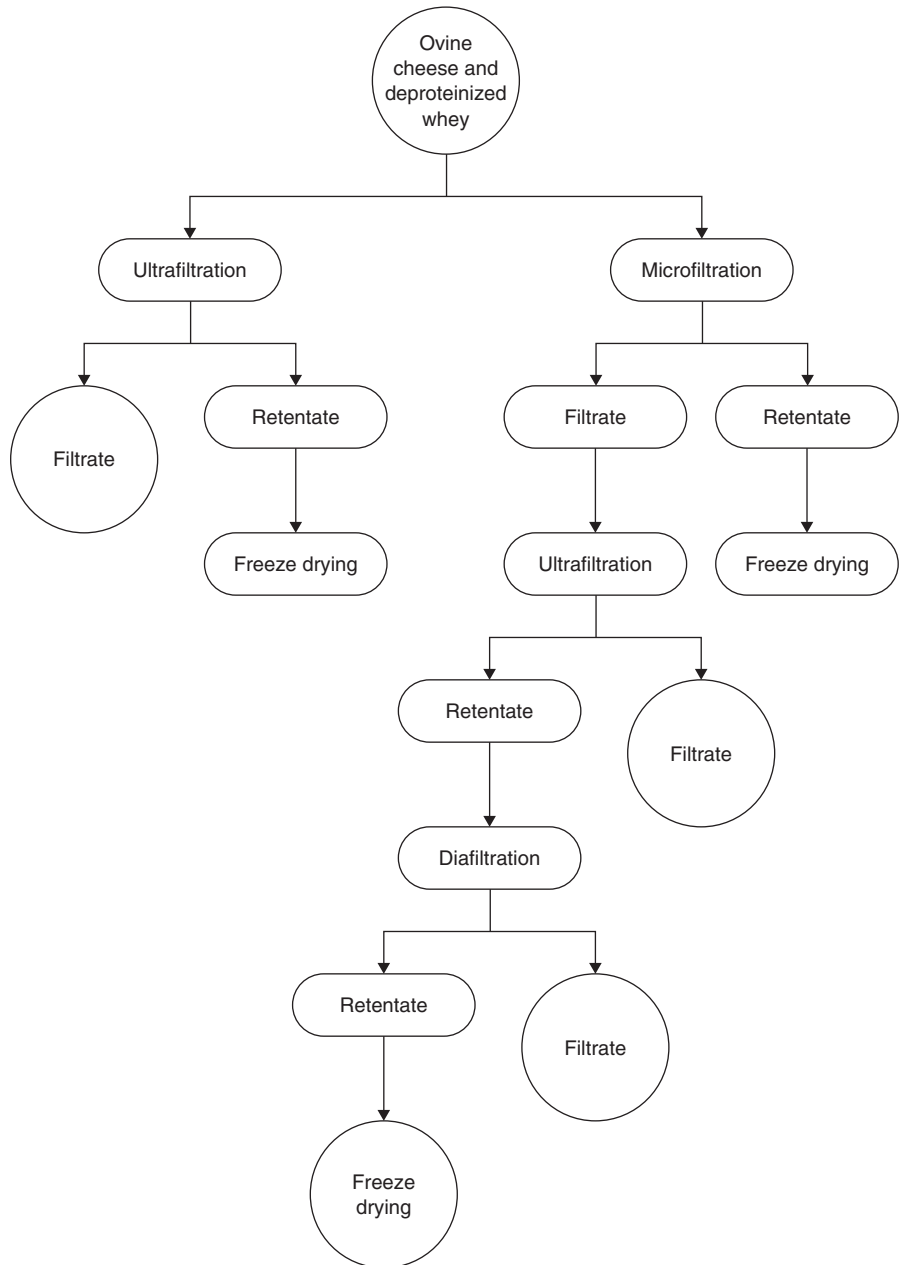

Figure 13.6 Process diagram of conventional ultrafiltration (UF) and thermocalcic precipitation-microfiltration of ovine cheese by-products (adapted from Pereira *et al.*, 2002)

buttermilk (39.1%) were reported. During the DF process, regular buttermilk doubled its phospholipid content, whereas that of whey buttermilk increased by 50%. In the VC process, total lipids transmission was 5.8% and 3% for regular and whey buttermilk, respectively, whereas in the DF process, transmission of lipids for regular and whey buttermilk was higher (8.5% and 4.7%, respectively).

Frappart and coworkers (2006) treated dairy process waters, modeled by diluted milk, using dynamic nanofiltration with a rotating disk module. Skimmed milk, diluted 1:2 with initial, was fed in a filtration system consisting of a metal disk (smooth or with radial vanes) rotating at high speed near a flat circular membrane operated at a transmembrane pressure (TMP) of 4000 kPa, at 45°C and at rotation speeds of 1000 and 2000 rpm. Concentration tests were also conducted at both types of disks, at TMP of 2000, 3000 and 4000 kPa, at 45°C and at rotation speed of 2000 rpm. At TMP of 4000 kPa and 2000 rpm (with vanes), permeate flux decreased up to 56.5% with increasing volume reduction ratio (VRR) from 1 to 7.5. The maximum dry matter percentage was 38% and obtained using a disk with vanes rotating at 2000 rpm. Permeate COD and mean ionic concentration increased with increasing VRR values at 2000 rpm irrespective of disc type, while COD was higher with smooth disks than disks with vanes.

Constructed wetlands

Constructed wetlands treatment involves a sediment retention and nutrient removal treatment system that uses natural chemical, physical and biological processes involving wetland vegetation, soils and their associated microbial populations to improve water quality (http://www.sera17.ext.vt.edu/Documents/BMP_Constructed_Treatment_Wetlands.pdf). A dairy farm wetland is very appealing as a waste management method because it is low cost, with relatively low requirements for technology know-how and with careful planning and low energy input requirements after construction (Hammer, 1992).

Moir *et al.* (2005) treated wastewater derived from a dairy parlor, by means of a multiple-phase biological system. The system consisted of an aerated sequencing batch reactor (SBR) containing activated sludge, followed by a series of constructed wetlands. The wetland sequence was composed of one subsurface horizontal flow reedbed, followed by three banks of vertical flow reedbeds in series. In the SBR, a significant decrease of BOD₅ and COD up to 92.1–96.1% and 86.1–89.5%, respectively occurred. Treated wastewater in the wetlands exhibited reduced values in BOD₅ and COD ranging from 70.1 to 81.8% and from 56.6 to 64.5%, respectively. A substantial reduction in suspended solids (SS), ammonium, nitrate and phosphorus concentrations in treated wastewater was reported.

Tanner *et al.* (1995a, b) conducted two experiments in order to examine the effect of loading rate and planting on oxygen demand, suspended solids (SS), fecal coliforms (FC) (Tanner *et al.*, 1995a), total nitrogen (TN) and total phosphorus (TP) (Tanner *et al.*, 1995b) removal of dairy farm wastewaters in constructed wetlands. Four pairs of planted (*Schoenoplectus validus*) and unplanted gravel-bed wetlands were operated at retention times of 7, 5.5, 3 and 2 days, with in- and outflows sampled bimonthly for 20 months (Tanner *et al.*, 1995a, b). Influent water quality varied markedly over the trial period (carbonaceous biochemical oxygen demand (CBOD₅): 20–300 g/m³; SS: 60–250 g/m³; FC: 103–104 MPN/100 ml; TN: 10–110; NH₄-N: 5–70; and TP: 8–18 g/m³) (Tanner *et al.*, 1995a, b). CBOD₅ removal was up to 76–92% and 60–85% in planted and unplanted constructed wetlands, respectively. In planted channels BOD (CBOD₅ + NBOD) removal decreased from 80 to 50% at high loading

rates, whereas in unplanted wetlands BOD removal ranged from 60 to 85%. Furthermore, 75–80% SS and 90–99% FC removal was recorded for both planted and unplanted wetlands. Dissolved humic color in the wastewaters was not really affected at short retention times and reduced up to 40% at longer retention times (Tanner *et al.*, 1995a). On the other hand, TN removal in planted and unplanted channels was 48–75% and 12–41%, respectively and TP removal was 37–74% and 12–36%, respectively (Tanner *et al.*, 1995b).

An ecological treatment system (ETS) was applied for nutrients removal from dairy wastewater. The wastewater flowed through the anaerobic reactor, anoxic reactor, closed aerobic reactor, planted aerobic reactor, clarifier, subsurface wetland mesocosm, two more planted aerobic reactors and another clarifier and two more subsurface wetland mesocosms for 20 weeks prior to being discharged. The results showed 99% removal of ammonium-nitrogen ($\text{NH}_4\text{-N}$) and carbonaceous biochemical oxygen demand (CBOD) and 79% removal of orthophosphate ($\text{PO}_4\text{-P}$). Furthermore, nitrate and nitrite were also produced with effluent concentration of 0.53 mg/l, but removed effectively within the system. Therefore, ETS enhanced biological removal of nitrogen and phosphorus from dairy wastewater (Lansing and Martin, 2006).

A constructed wetland system consisting of two settling basins, two wetland cells planted with *Typha latifolia* L. and *Schoenoplectus tabernaemontani* and a vegetated filter strip colonized by *Lemna minor* L. and *Echinochloa crus-galli*, was operated for dairy wastewater treatment. The results indicated a significant reduction of total nitrogen (98%), ammonia (56%), total phosphorus (96%), ortho-phosphate (84%), suspended solids (96%) and biochemical oxygen demand (97%). On the contrary, nitrate/nitrite increased by 82%, due to the oxidation of ammonia via nitrification in the vegetated filter strip (Schaafsma and Baldwin, 1999).

Coagulation/electrocoagulation/flocculation/precipitation

Coagulation/flocculation is one of the most important physicochemical treatment steps in industrial wastewater treatment to reduce the suspended and colloidal materials responsible for turbidity of the wastewater and also for the reduction of organic matter which contributes to the BOD and COD content of the wastewater (Rossini *et al.*, 1999; Al-Mutairi *et al.*, 2004). On the other hand, electrocoagulation has been very successfully employed in removing oil/grease and SS from a variety of industrial effluents (e.g. oil refinery waste) (Chen *et al.*, 2000; <http://www.esemag.com/index.html>) and is a combined coagulation and flotation process induced by the passage of electric current.

Şengil and Özacar (2006) looked into the potential of treating wastewater obtained from a dairy factory using direct current electrocoagulation. The effect of initial pH (3.5–10.0), electrolysis time (1–6 min), initial concentration of COD (1550–19800 mg/l), conductivity (0.77–4.61 mg/l) and current density (0.3–1.8 mA/cm²) on COD and oil-grease concentration were also studied. The experiment was conducted in an electrochemical reactor consisting of iron electrodes at 25°C, 0–15 V and 0–3 A. COD and oil-grease removal up to 98% and 99%, respectively, were reported. The optimum current density, pH and electrolysis time for treating dairy wastewater with COD of

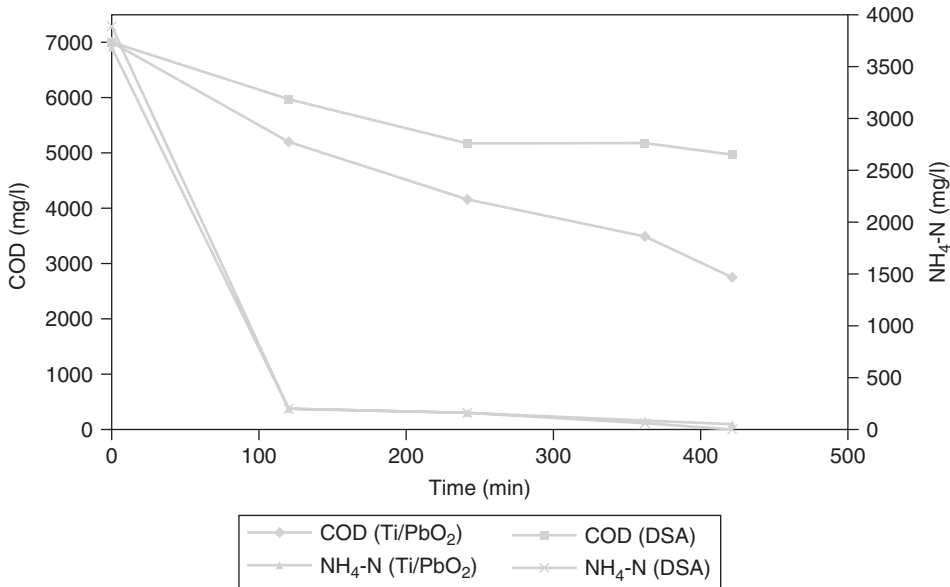

Figure 13.7 Decrease of NH₄-N and COD during electrochemical oxidation of dairy manure (adapted from Ihara *et al.*, 2006)

18 300 mg/l and oil-grease of 4570 mg/l were 0.6 mA/cm², 7 and 1 min, respectively, while energy consumption was estimated at 0.003 kWh/kg of COD.

The electrochemical oxidation of the effluent from anaerobic digestion of dairy manure was investigated by Ihara *et al.* (2006). The digested effluent obtained from a full-scale anaerobic digester was pretreated with membrane filters for suspended solids (SS) removal, prior to electrochemical oxidation experiments. Direct anodic oxidation and indirect oxidation were evaluated through the use of a dimensionally stable anode (DSA) and lead dioxide coated titanium (Ti/PbO₂) as anode and stainless steel as cathode. The results showed that the decreasing rate of NH₄-N was higher at the DSA than Ti/PbO₂ anode, whereas the decreasing rate of COD was higher at the Ti/PbO₂ than the DSA anode (Figure 13.7). Moreover, the electrochemical oxidation with DSA prevented the accumulation of NO₃-N. NaCl addition to the sample before membrane filtration considerably increased the decreasing rate of NH₄-N.

The effluents from two different anaerobic reactors for dairy manure (one- and two-phase) were subjected to struvite precipitation to remove ammonia nitrogen. Struvite is a white crystalline solid formed according the following reaction: $Mg^{2+} + NH_4^+ + PO_4^{3-} + 6H_2O \rightarrow MgNH_4PO_4 \cdot 6H_2O$. Struvite precipitation experiments were conducted in continuously stirred batch reactors at room temperature (21–22°C) by adding Mg²⁺ in the form of Mg(OH)₂ and MgCl₂·6H₂O. The results indicated that ammonia (NH₄⁺) removal above 95% can be achieved by adding 0.06 M Mg²⁺ to the effluents obtained from one- and two-phase reactors. MgCl₂·6H₂O proved to be more effective in NH₄⁺ removal than Mg(OH)₂, while less Mg²⁺ was required in the effluent from a two-phase reactor to achieve similar removal efficiencies compared to the effluent from a one-phase reactor (Uludag-Demirer *et al.*, 2005).

Table 13.2 Dairy wastewater analysis during membrane processing in laboratory and pilot scale studies

	After chitosan (10 mg/l)		After PAC (1.5 g/l)		MF permeate		RO permeate	
	Laboratory scale	Pilot scale	Laboratory scale	Pilot scale	Laboratory scale	Pilot scale	Laboratory scale	Pilot scale
TDS (mg/l)	260–440	470	100–200	360	–	300	57–90	33
COD (mg/l)	203–583	295	203–388	197	–	197	81–117	16.5
BOD (mg/l)	–	520	–	440	–	85	–	8

Adapted from Sarkar *et al.*, 2006

Wastewater derived from a dairy farm was subjected to coagulation with inorganic (alum and ferric chloride), polymeric (polyaluminium chloride) and natural organic (sodium carboxymethyl cellulose, alginic acid and chitosan) coagulants, followed by powdered activated charcoal (PAC) treatment and pH adjustment to 6.5. Laboratory-scale experiments were then conducted and the wastewater went through ultrafiltration (UF) and reverse osmosis (RO) membranes separately. Pilot-scale studies were also performed and the water went through microfiltration (MF) and RO membranes. The results revealed that the optimized conditions for wastewater treatment were with 10 mg/l chitosan, 1.5 g/l dosage of PAC and pH adjustment to 4.0. Under these conditions, 57% total dissolved solids (TDS) and 62% COD reduction were reported, while the color and the odor had been eliminated. In laboratory-scale studies, TDS and COD decrease were not significant after ultrafiltration, even though a 90.8–91.8% TDS decrease and 80–91% COD removal was observed in the RO permeate. In pilot scale studies, TDS, COD, and BOD removal of RO permeate was 95.8%, 98.5% and 95.8%, respectively (Table 13.2). The quality of water after reverse osmosis was comparable to that of dairy process water and can be recycled back (Sarkar *et al.*, 2006).

Bioremediation

Bioremediation is the naturally occurring process through which microorganisms either immobilize or transform environmental contaminants to innocuous end products (Thassitou and Arvanitoyannis, 2001). Successful treatments of dairy effluent through bioremediation and its safe release into the water or environment have been developed in Hungary (Kis and Ujhelyi, 1988; Szego, 1988; Kis, 1993), India (Venkataraman *et al.*, 1988a, b; Mehadia and Ingle, 1995), Ireland (Fallowfield and Garrett, 1985), Italy (Felice and Scioli, 1994), Japan (Hayashi *et al.*, 1984), Spain (Mateos *et al.*, 1986) and The Netherlands (Mulder *et al.*, 1982). The basic objective of treating the dairy effluent is to reduce its adverse impact on flora and fauna. The success of any treatment including bioremediation, however, depends on the choice of a suitable agent in the correct place under the proper environmental conditions (Mishra *et al.*, 2000).

The nutrient removal capacity of three aquatic macrophytes, such as *Eichhornia crassipes*, *Lemna minor* and *Azolla pinnata*, and their combination was investigated by

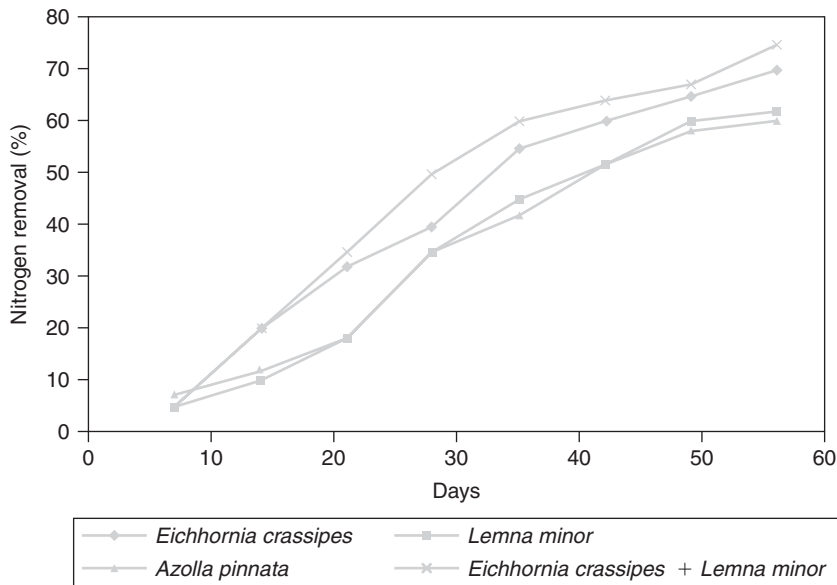

Figure 13.8 Nitrogen removal by aquatic macrophytes (individually and combination) (adapted from Tripathi and Upadhyay, 2003)

Tripathi and Upadhyay (2003). All three plants were cultured individually (monoculture) with 100% cover and in combinations, and then placed in separate aquaria. Each aquarium was filled with dairy effluent, while control experiments were also performed using dairy waste without any macrophyte. Nitrogen (N) removal by *E. crassipes*, *Lemna minor* and *Azolla pinnata* was 71.8%, 62.5% and 60.1%, respectively. On the other hand, phosphorus (P) removal by *E. crassipes*, *Lemna minor* and *Azolla pinnata* were 63.2%, 58.8% and 56.3%, respectively. The highest removal of N (78.8%) and P (69.4%) was reported in mixed culture of *E. crassipes* and *L. minor*. An increase in N and P content in plant tissues was also reported (Figures 13.8 and 13.9).

The potential of cellulase/ β -glucosidase production by a mixed fungi culture of *Trichoderma reesei* and *Aspergillus phoenicis* on dairy manure was investigated by Wen *et al.* (2005). Dairy manure (at different concentrations) supplemented with 2 g/l KH_2PO_4 , 2 ml/l tween-80 and 2.0 mg/l CoCl_2 was inoculated with pure culture of either 10% (v/v) *T. reesei* (25.5°C and pH 5.76) or 10% (v/v) *A. phoenicis* (28.2°C and pH 5.14). For mixed culture, 10% (v/v) *T. reesei* and 10% (v/v) *A. phoenicis* were inoculated in manure at 27.8°C and pH 5.5. Cellulase with a high level of β -glucosidase was produced in the mixed culture of *T. reesei* and *A. phoenicis* (Figure 13.10). Additionally, β -glucosidase activity and filter paper activity were 0.64 IU/ml and 1.54 FPU/ml, respectively. The glucosidase concentration produced was considerably higher than that produced over manure treatment with commercial enzyme and enzyme broth of the pure culture of *T. reesei*.

Sugarcane trash and cattle dung were blended at different proportions (4:1 or 1:1 dry weight basis) and the blend was turned after 14, 30, 45, 60 and 90 days, while moisture was maintained at 60% of water-holding capacity (WHC) and the temperature

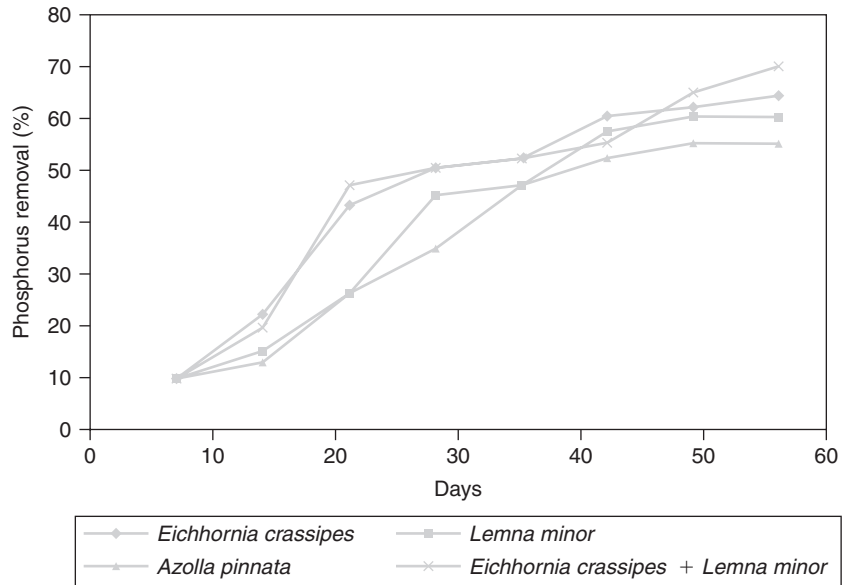

Figure 13.9 Phosphorus removal by aquatic macrophytes (individually and combination) (adapted from Tripathi and Upadhyay, 2003)

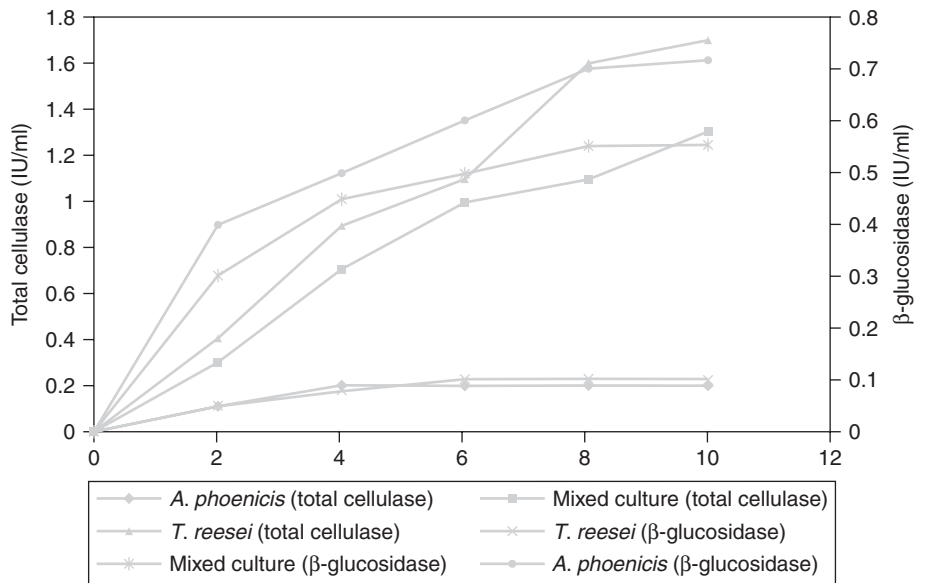

Figure 13.10 Total cellulase and β -glucosidase production by pure culture of *T. reesei* and *A. phoenicis* and the mixed culture of both fungi (adapted from Wen *et al.*, 2005)

ranged from 28–30 to 45°C. The results revealed that organic carbon and C/N ratio decreased with time, whereas total nitrogen content increased with time. Maximum enzyme activities for cellulase, xylanase and protease were reported after 30 and 60 days of composting. The population of thermophilic and mesophilic bacteria was

Table 13.3 Changes in organic C, total N, C:N ratio, cellulose, xylase protease activity and mesophilic and thermophilic population during composting of cattle dung waste

	Sugarcane trash and cattle dung (4:1)					Sugarcane trash and cattle dung (1:1) (days)				
	0	14	30	60	90	0	14	30	60	90
Organic C (%)	47.5	–	44.1	43.0	41.3	48.0	–	44.7	43.8	38.9
Total N (%)	0.9	–	1.2	1.4	1.4	1.5	–	1.5	1.7	1.9
C:N ratio	51.1	–	36.1	30.3	28.3	32.0	–	29.2	25.6	20.5
Cellulase activity (mg reducing sugar/ kg dry matter/h)	8.0	–	103.0	81.0	36.0	26.0	–	197.0	123.0	51.0
Xylase activity (mg sugar/kg dry matter/h)	22.0	–	42.0	53.0	30.0	16.0	–	65.0	83.0	51
Protease activity (mg tyrosine/ kg dry matter/h)	159.0	–	1030.0	1520.0	1183.0	309.0	–	717.0	1524.0	1198.0
Mesophilic bacterial population (10^7 /g material)	13.8	24.0	207.0	75.0	72.0	9.8	21.2	215.0	114.0	84.0
Thermophilic bacterial population (10^5 /g material)	6.0	50.4	8.0	1.8	0.6	2.0	88.2	24.0	2.4	1.2

Adapted from Goyal *et al.*, 2005

found to be highest at 14 and 30 days of composting, respectively and declined with time. On the other hand, the mesophilic fungal population had the highest value at 30 days of composting and decreased with time. The thermophilic population was reduced constantly during composting (Table 13.3) (Goyal *et al.*, 2005).

The ability of a commercial inoculum to degrade high fat content dairy wastewater aerobically was examined by Loperena *et al.* (2006). Industrial dairy wastewater with a high fat content (COD concentration 0.5–4 g/l) was fed into a batch mode bioreactor at pH 7, 30°C and 200 rpm. Moreover, continuous mode experiments were conducted using either industrial effluent or model effluent consisting of homogenized whole milk (COD concentration 0.5–1.9 g/l) at 19–23°C. During batch tests, COD removal was up to 78%, CO₂ production was 1.1 g/g of COD removed and biomass yield reached the level of 0.41 g volatile suspended solids (VSS)/g of COD removed. On the other hand, the COD removal amounted to 89% when the continuous mode bioreactor was fed with industrial wastewater.

Municipal solid wastes, such as mixed paper waste (old corrugated cardboard, printed office paper and old newsprint), food waste (milk, cooked pasta, hamburger, lettuce, raw potatoes and carrots) and yard waste (grass clippings and leaves), were composted individually or at different mixtures in an aerobic digester operated at $52 \pm 2^\circ\text{C}$ (thermophilic temperature) for 47–198 days. Partially composted municipal solid wastes were added to some runs and the experiment ended when carbon dioxide production rates dropped below 0.5 g CO₂-C/dry kg/day. The addition of partially composted municipal waste to paper or yard or food waste, each one composted

individually, caused emission of 150, 220 and 370 g CO₂-C and 2.0, 4.4 and 34 g NH₃-N per dry kg of starting material, respectively. In all mixtures, the CO₂ emission ranged from 240 to 300 g CO₂-C per dry kg of initial substrate, while NH₃ production was 0.5–15 g NH₃-N per dry kg of initial substrate (Komilis and Ham, 2006).

Kosseva and his colleagues (2003) compared two bioremediation strategies of cheese whey treatment, using a mesophilic and thermophilic population of *Streptococcus* spp. and *Bacillus* spp., respectively. The first one consisted of an anaerobic, mesophilic (45°C) first stage, followed by an aerobic, mesophilic (45°C) second stage. The second one included an anaerobic, mesophilic (45°C) first stage, followed by an aerobic, thermophilic (55–65°C) second stage. The results indicated that dissolved oxygen (DO) was maintained at or above 80% of saturation during aerobic processing, whereas DO remained at above 65% of saturation during the thermophilic stage. COD decrease of whey during the anaerobic and aerobic stages was 68%, while soluble protein decline was up to 59%. Considering only the thermophilic treatment, the average decrease of COD and soluble protein was 62.5%, and 47.5%, respectively. In the mesophilic-thermophilic strategy, approximately 100% reduction of COD and lactose were reached, accompanied by a 90% decrease in soluble protein in batch cultures.

Miscellaneous treatment methods

A two-step hydrolysis of fibers from dairy manure involving concentrated acid decrystallization followed by dilute (less than 15%) acid hydrolysis was performed by Liao *et al.* (2006). Pretreated dairy manure with two nitrogen content levels (1.3% and 2.6%) was diluted to three different acid concentrations (65%, 70% and 75%) and used for concentrated acid hydrolysis experiments carried out at 100°C for 1 h at four treatment durations (30, 60, 90 and 120 min). Decrystallized manure was subject to acid hydrolysis under two acid concentrations (10% and 12.5%), three levels of temperatures (100, 120 and 135°C) and six reaction times (10, 20, 30, 60, 90, 120, 150 and 180 min). The optimal conditions for decrystallization were 75% acid concentration, 3:5 sample to acid ratio (weight basis) and 30 min reaction time; whereas the optimal conditions for acid hydrolysis were 12.5% acid and 10% dry sample at 135°C for 10 min. Under these conditions, 84% glucose (26 g/l) and 80% hemicellulose-sugars (11 g/l) were obtained.

Dairy manure was fed into the first (acidifying) reactor, operated for 26 days at an SRT/HRT of 10 days and organic loading rate (OLR) of 1.19 g COD/l day (1.0 g VS/l day). The obtained effluent was then fed to the second (methanogenic) reactor, run at the same OLR and influent VS concentration (0.91%) for 21 days. For the following 86 days, the two-phase reactor was operated at SRT/HRT of 10 days, at different OLR (2.39–15.06 g COD/l day or 2.0–12.6 g VS/l day, respectively) and influent VS concentrations (1.83–11.5%). Dairy manure was also fed into a conventional one-phase reactor at an SRT/HRT of 10 or 20 days at various OLR (0.96–3.01 g COD/l day or 1.0–3.15 g VS/l day, respectively) and influent VS concentrations (3.65–5.75%). In the two-phase reactor, the highest biogas production rate was 2.272 l/day at OLR of 7.53 g COD/l day, while the highest biogas yield was 1.76–1.78 l biogas/g VS added at OLR of 5.97 and 7.53 g COD/l day. Biogas production was 50% and 67% higher at

ORL of 5.97 and 7.53 g COD/l day, respectively, compared to conventional one-phase reactor with SRT/HRT of 20 days. Moreover, in the two-phase reactor, cost savings were significant due to superior performance and reduced volume requirements. In the two-phase reactor COD and VS removal was 30–71% and 16–70%, respectively. In the one-phase reactor at SRT/HRT of 20 days, a 45–77% COD and 36–70% VS decrease was reported and at SRT/HRT of 10 days, 24–50% COD and 16–40% VS decline was recorded (Demirer and Chen, 2005).

Flushed dairy manure was initially flowed down to a sand-trap, where some of the sand was recovered and used as bedding and then flowed to a mechanical separator for large fibrous solids removal. The separated wastewater was directed to a sedimentation basin and then into a sampling pit and a storage pond. Pretreated wastewater was pumped to an anaerobic lagoon, where the liquid was irrigated onto cropland. Solids removed with the mechanical separator and sedimentation basin were spread directly onto croplands (Figure 13.11). The results showed that, during wastewater screening and sedimentation, total solids (TS), volatile solids (VS) and total COD removal was up to 46.7%, 60.4% and 42.2%, respectively. Higher flushed dairy manure temperatures reduced TS, VS and total COD removal efficiencies. A substantial portion of the methane potential remains in the wastewater, due to removal of solids that are relatively non-degradable fibers and do not contribute to methane production (Wilkie *et al.*, 2004).

Organophilic clay, made from a smectitic clay with quaternary ammonium salt, was used to study the adsorption of the residual lactose which is not extracted from dairy industry effluents by conventional methods, by Morais *et al.* (2005). Lactose adsorption was studied at 30°C using aqueous concentrations from 200 to 1000 mg/l. The results indicated that the amount of lactose adsorbed by the organophilic clay was very small and ranged from 0.3 to 0.5%.

Danalewich *et al.* (1998) carried out an experiment to determine the effectiveness status of current dairy wastewater treatment practices and to estimate the potential for biological nutrient removal (BNR). In their study, 14 dairy industries, 12 of which produced one or more types of cheese and processed dairy whey as a secondary product, were included. Significant reduction in the volume of wastewaters produced per amount of milk processed, due to the increased plant size, the automation in product processing and the introduction of cleaning-in-place (CIP) systems over the last few decades were reported. However, the effectiveness/ineffectiveness of management strategies is still the critical factor determining the waste generation.

Table 13.4 provides a synoptic presentation of the most important treatment methods (parameters, quality control and results) of dairy industry waste.

Uses

Wastewater reclamation and re-use is currently of increasing interest in many parts of the world in response to a growing demand for reliable, high quality water supplies, particularly in drought-prone areas (Asano and Levine, 1996; Crook and Surampalli,

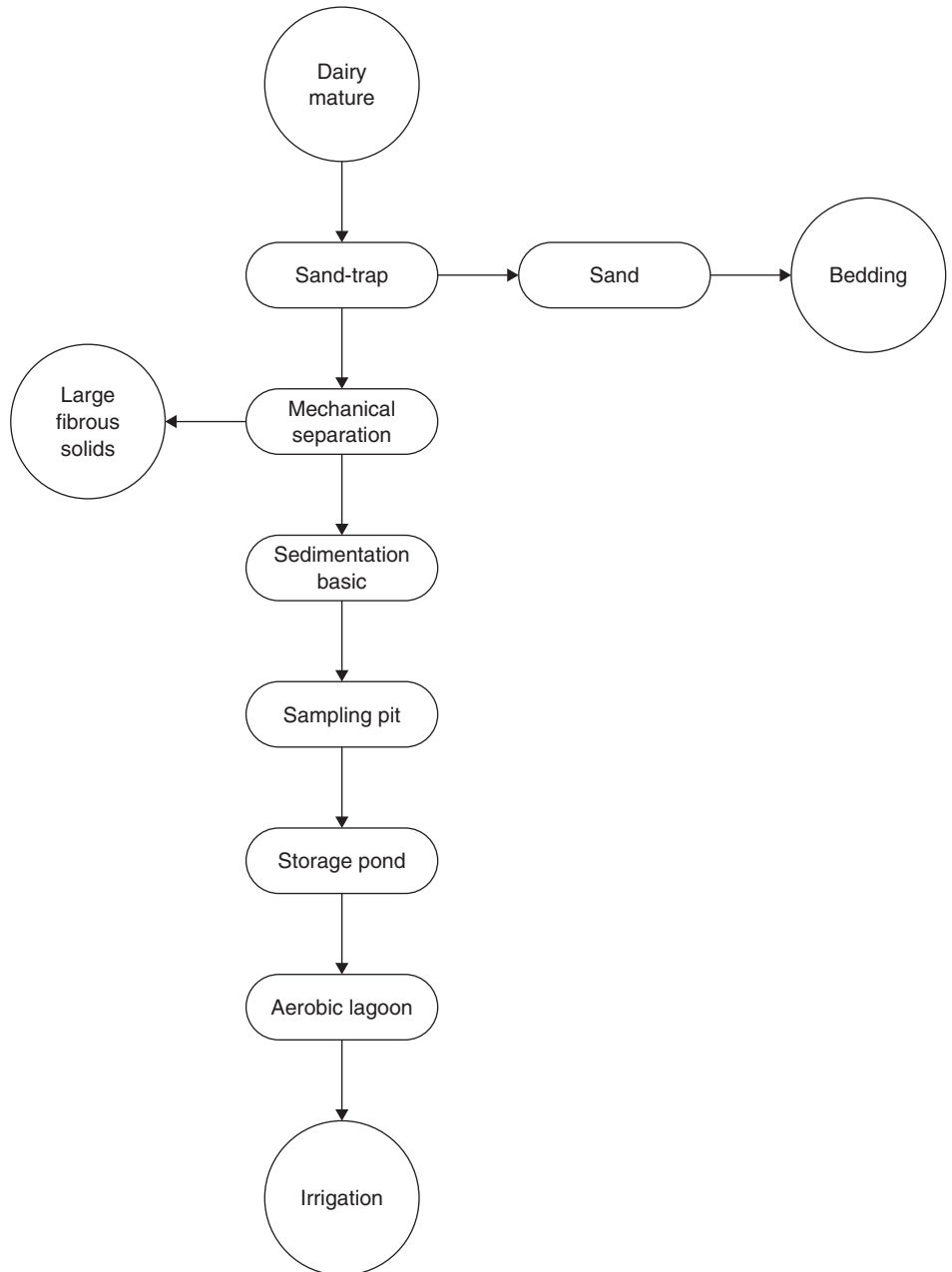

Figure 13.11 Fixed-film anaerobic digestion of flushed dairy manure after primary treatment (adapted from Wilkie *et al.*, 2004)

1996) and attention to integrated resource management and sustainability issues (Hermanowicz and Asano, 1999; Sala and Serra, 2004). Treated dairy waste has found many applications among which the most important are for biogas/biodiesel production, fertilizer, animal feedstuff, the food industry and miscellaneous uses.

Table 13.4 Treatment methodologies of dairy industry waste: parameters, quality control and results

No	Kind of waste	Treatment	Parameters	Methodology	Quality control methods	Results	References
<i>A Aerobic treatment</i>							
1	Wastewater	Aerobic purification	pH, TCOD, SCOD, TS, TSS, VSS, DO, SVI, biomass nitrogen content	The wastewater was first fed into a single reactor (30 days minimum operation time) and then into a three-stage reactor (50 days minimum operation time)	<ol style="list-style-type: none"> 1 pH: pHmeter 2 TCOD, SCOD: filtering through a 0.45 m pore diameter membrane filter (by the dichromate reflux method 508) 3 TS: dried at 103–105°C (2540B) 4 TSS: 2540 D 5 VSS: 2540 E 6 DO: membrane electrode method (4500-0G) 7 SVI: 2710 D 8 Biomass nitrogen content: Kjeldahl method 	<p><i>System I:</i></p> <ol style="list-style-type: none"> 1 System overload at loads >0.741 kg/m³ COD/day 2 Treatment efficiencies: >96.8% 3 pH stabilization <p><i>System II:</i></p> <ol style="list-style-type: none"> 1 TCOD and SCOD reduction by 50 and 70%, respectively 2 Treatment efficiencies: >98.5% <p><i>Both systems:</i></p> <p>Minimum organic matter removal: 82% (at loads >1 kg/m³ COD/day)</p>	Carta-Escobar <i>et al.</i> , 2004
<i>B Anaerobic treatment</i>							
2	Wastewater	Treatment with upflow anaerobic sludge blanket (UASB) reactors	pH, COD, VFAs, biogas quantity and quality	Two types of UASB reactors (anaerobic sludge granules from digested cowdung slurry (DCDS) (reactor I) and granules obtained from reactors treating sugar industry wastewaters (reactor II)) were operated at hydraulic retention time (HRT) of 3 and 12 h and on COD loading rates 2.4–13.5 kg/m ³ of digester volume/day	<ol style="list-style-type: none"> 1 pH: pH meters 2 COD: open reflux method (APHA, 1998) 3 VFAs: method of Dilallo and Albertson (1961) 4 Biogas quantity: wet gas flow meters 5 Biogas quality: AIMIL-make gas liquid chromatograph using thermal conductivity detectors 	<ol style="list-style-type: none"> 1 3 h HRT: 95.6 and 96.3% maximum COD reduction from the reactor I and II, respectively 2 12 h HRT: 90 and 92% COD reduction in reactor I and II, respectively 3 Both reactors: maximum, second best and the third best COD reduction occurred at loading rates of 10.8, 8.6 and 7.2 kgm³/day, respectively 4 At loading rates >10.8 kg: reactor's performance dropped 5 Better biodegradation of the waste: the first few months of both reactors 	Ramasamy <i>et al.</i> , 2004
3	Dairy effluent	Anaerobic treatment	pH, total biogas production, alkalinity, total VFA, individual volatile fatty	A high-rate anaerobic reactor operated for 400 days	<ol style="list-style-type: none"> 1 pH: pH probe 2 Total biogas production: wet-gas flow meter 3 Alkalinity and VFA concentration: 	<ol style="list-style-type: none"> 1 90% COD removal at organic loading rate of 10 g COD/m³/day 2 COD recovery as methane was close to 100% (0.37 l CH₄/g COD removed) 	Haridas <i>et al.</i> , 2005

(Continued)

Table 13.4 (Continued)

No	Kind of waste	Treatment	Parameters	Methodology	Quality control methods	Results	References
			acids, TOC, IC, biogas composition, COD, LCFAs		titrimetrically (Anderson and Yang, 1992) 4 Individual volatile fatty acids: gas chromatography 5 TOC and IC: TOC-system 6 Biogas composition: TOC analyzer 7 COD: open reflux method according to Standard Methods (APHA <i>et al.</i> , 1995) 8 LCFAs: by GC	3 Scum accumulation and degradation before stable methanation 4 Complete degradation of scum when the reactor was unfed (starvation tests)	
4	Synthetic black water and dairy parlor wastewater	Anaerobic on-site treatment	TCOD, COD _{ss} , COD _{col} , TSS, VSS, TS, VS, N _{tot} , pH, BOD ₇ and P _{tot} , methane	The wastes were fed into UASB-septic tanks at low temperatures (10–20°C) for 398 days	1 COD _i : according to Finnish standard methods (SFS 5504, 1988) 2 COD _{ss} : obtained by subtracting paper filtered COD from COD _t 3 COD _{col} : by subtracting membrane filtered COD from paper filtered COD 4 TSS, VSS, TS and VS: according to Standard Methods (APHA, 1998) 5 N _{tot} : according to Tecator application note (Perstorp Analytical/Tecator AB, 1995) 6 pH: pH meter 7 BOD ₇ and P _{tot} : according to Finnish standard methods (SFS-EN 1899-1, 1998; SFS 3026, 1986, respectively) 8 Methane: GC	1 80% and 90% total chemical oxygen demand (COD _t) removal 2 >90% total suspended solids (TSS) removal 3 Dissolved COD (COD _{dis}) and BOD ₇ removal was 70% and 93%, respectively 4 Good COD and solids removals in a single-phased reactor for black water and a two-phased system for dairy parlor wastewater 5 High black water nutrient removal, while low dairy parlor nutrient removal	Luostarinen and Rintala, 2005
5	Dairy manure	Anaerobic treatment	TS, VS, VSS, VFAs, ammonia-nitrogen, pH, total coliforms, biogas	Two thermophilic (55°C)–mesophilic (35°C) anaerobic sequencing batch reactor ASBR	1 TS, VS, VSS, VFAs: according to Standard Methods (APHA, 1992) 2 Ammonia-nitrogen:	1 Both HRTs: high solid retention time (SRT) of 13–18 days for all three systems	Dugba and Zhang, 1999

				systems (systems II and III) and one mesophilic (35°C)-mesophilic (35°C) ASBR system were run at two hydraulic retention times (HRTs) (3 and 6 days) and five volatile solids (VS) loading rates (2, 3, 4, 6 and 8 g/l/day)	gas-sensing electrode 3 pH: pH-meter 4 Total coliforms: according to Standard Methods (APHA, 1992) 5 Biogas: by GC	2 HRT of 3 days and VS loading rates of 6 g/l/day: all systems performance was deteriorated 3 HRT of 3 days: ideal VS loading rates were 2–4 g/l/day 4 26.1–44.2% VS removal, 0.2–1.6 l/l/day specific methane production from three systems 5 Biogas: 62–66% CH ₄ , 28–31% CO ₂ . A 6 37% NH ₃ -N concentration increase in treated wastewater 7 Systems with thermophilic reactors: effective in destroying total coliforms	
6	Dairy wastewater	Anaerobic biodegradation	Protein, total sugars, VFA _s , TA, sugar, TSS, VSS, TOC, IC, methane gas	Anaerobic biodegradability batch assays of two types wastewater (COD 0.4–20 g/l) (wastewater A from dissolving full cream milk powder, wastewater B from skimmed milk powder)	1 Protein: by spectrophotometry 2 Sugars: according to method described by Miller (1959) 3 VFA _s : by GC 4 TA: by anion selective electrode 5 Sugar, TSS, VSS: according to Standard Methods (APHA, 1985) 6 TOC, IC: by TOC-analyzer 7 Methane gas: by GC	1 Wastewater A: greater biodegradability and methanization at lower concentrations (1–5 g COD/l) 2 Wastewater A: 98–99% biodegradability at higher concentrations (5–20 g COD/l) 3 Wastewater B: biodegradability decline from 97.5 to 86% 4 Wastewater B: methane production increased linearly with COD increase 5 Wastewater A: methane production increased at low COD (<5 g/l) and inhibited at higher concentrations (>6 g COD/l) 6 Wastewater B: total volatile fatty acids (VFA) accumulation at high COD (5–20 g COD/l), and high free ammonia concentration (60 mg/l) at high COD values (20 g/l)	Vidal <i>et al.</i> , 2000
7	Dairy wastewater	Mesophilic anaerobic degradation	VFA, methane, chemical analysis	UASB reactors with different intermittent cycle length 24–144 h and loads 2.5–29.0 g	1 VFA, methane: by GC 2 Chemical analysis: according to Standard Methods (1995)	1 Methane production: higher in the feedless period (22% to 36% of the total methane) compared to the total cycle production	Nadais <i>et al.</i> , 2005

(Continued)

Table 13.4 (Continued)

No	Kind of waste	Treatment	Parameters	Methodology	Quality control methods	Results	References
				COD/l/day were fed with dairy wastewater (treatments: feed and feedless period)		2 96–98%COD removal ×48 h feed and 48 h feedless period: higher conversion of removed COD to methane raised from 59 to 85%	
8	Mixed liquor (synthetic dairy waste, fresh cow-dung slurry, digested cow-dung slurry)	Anaerobic digestion	TS, VS, COD, pH, biogas	Mixed liquor, which was then replaced with dairy waste, was fed into a continuously-stirred tank reactor (CSTR) by incorporating a biofilm support system (BSS) with HRT of 15 days	1 TS, VS, COD, pH: according to Standard Methods (APHA, 1995) 2 Biogas: by GC	1 Low COD and pH reduction in the effluent 2 Dairy waste (the only feed substrate): biogas yield and pH increased 3 Greater COD reduction in the BSS reactors than in the conventional ones 4 60% volatile solids (VS) decline in the BSS reactors and only 40% in the control (HRT 10 days) 5 56–58% biogas release by both reactors	Ramasamy and Abbasi, 2000
<i>C Membrane treatment</i>							
9	Diluted skimmed milk	Nanofiltration and reverse osmosis	COD, lactose, conductivity, anions and cations	A mixture of water and skimmed milk was filtrated with different membranes in a batch cell (25°C, 1.5 MPa for NF membranes, 2.5 MPa RO membranes, filtration time 8–9 h)	1 COD: test tubes (oxidation with potassium dichromate/sulfuric acid/silver sulfate at 148°C) and photometric measurement 2 Lactose: spectrophotometrically at 488 nm 3 Cations (Na ⁺ , K ⁺ , Ca ²⁺ , Mg ²⁺) concentrations: by atomic absorption 4 Anions (phosphate, citrate, Cl ⁻) concentrations: ion chromatography 5 Conductivity: conductivity meter	1 COD removal: >99% 2 Lactose removal: 98.2–99.9% 3 Divalent cations removal: >90% 4 Negative rejection of chloride at VRF = 3 using NF membranes 5 Permeate COD levels were significantly higher than the threshold acceptable for human consumption water	Balannec <i>et al.</i> , 2005
10	Ovine by-products (ovine cheese whey and	Membrane treatment	Protein, fat, dry matter, ash, chloride, Ca ²⁺ , PO ₄ ²⁻	Ultrafiltration (UF) (<i>Treatment I</i>) and thermocalcic precipitation–microfiltration (TP/MF)	1 Protein and fat: infrared spectroscopy 2 Dry matter: oven drying at 105°C for 12 h	1 0.65 mm pore size of MF membranes: more efficient clarification and the obtained product had high protein	Pereira <i>et al.</i> , 2002

	deproteinized whey)			using two MF membranes (0.65 and 0.20 mm pore size) followed by UF and diafiltration (UF/DF) (<i>Treatment II</i>)	<ol style="list-style-type: none"> 3 Ash: incineration at 550°C for 6 h 4 Protein: Kjeldahl method 5 Fat: gravimetric AOAC procedure (AOAC, 1996a) 6 Chloride: kit 7 Ca²⁺: atomic absorption spectrometry 8 PO₄²⁻: colorimetric method of AOAC (1996b) 	<p>content and can be used in food industry</p> <ol style="list-style-type: none"> 2 0.20 mm pore size of MF membranes: poor flux performance and high degree of protein retention 	
11	Skimmed milk	Enzymatic hydrolysis	Enzyme activity, glucose, lactose, galactose, glucose concentrations	Skimmed milk was pumped through a hollow fiber module (heat exchanger, manometer, thermometer). At the end of the module, lactose-hydrolyzed product was collected. The enzyme (β -galactosidase) was pumped in a closed circulation, which included a UV irradiation module and a sterile filtration unit	<ol style="list-style-type: none"> 1 Enzyme activity: according to method described by Petzelbauer <i>et al.</i> (1999) 2 Glucose: by glucose analyzer 3 Lactose, galactose, glucose concentrations: with HPLC 	Lactose conversion decrease from 92.48 to 78.11% (enzyme activity 120 U/ml, 23 \pm 2°C, hollow fiber reactor with membrane area of 4.9 m ²)	Novalin <i>et al.</i> , 2005
12	Regular and whey buttermilk	Volumetric concentration (VC) and diafiltration (DF)	Total solids, ash, protein, lipids, phospholipids	Use of a ceramic microfiltration (MF) membrane using two different filtration modes, VC and DF, at low temperature (8–10°C) at a transmembrane pressure of 80–95 kPa	<ol style="list-style-type: none"> 1 Total solids: drying in an air oven at 102°C 2 Ash: by incineration at 550°C in a muffle furnace 3 Protein: by macro-Kjeldahl method with 6.38 as a nitrogen to protein conversion factor (Marshall, 1992) 4 Lipids: by Mojonnier ether extraction method (Marshall, 1992) 5 Phospholipids: with HPLC 	<ol style="list-style-type: none"> 1 DF process: decrease of protein transmission through the membrane (19.5% regular and 25% whey buttermilk), decrease of ash transmission for regular buttermilk (65.5%), increase in phospholipids transmission for regular buttermilk (39.1%), increase of phospholipids content for regular and whey buttermilk, transmission of lipids for regular and whey buttermilk was 8.5% and 4.7%, respectively 2 VC process: decrease of protein transmission for whey buttermilk (33.0%), total lipids transmission for regular and whey buttermilk 	Morin <i>et al.</i> , 2006

(Continued)

Table 13.4 (Continued)

No	Kind of waste	Treatment	Parameters	Methodology	Quality control methods	Results	References
13	Diluted skimmed milk	Nanofiltration with a rotating disk module	COD, conductivity, pH, dry mass	Diluted skimmed milk fed into a filtration system consisting of a metal disk (smooth or with radial vanes) rotating at high speed near a flat circular membrane operated at a transmembrane pressure (TMP) of 4000 kPa, at 45°C and at rotation speeds of 1000 and 2000 rpm	<ol style="list-style-type: none"> 1 COD: by kits 2 Conductivity: by conductivity meter 3 pH: by pH-meter 4 Dry mass: percentage of total mass after heating the samples at 105°C for 7 h 	<p>was 5.8% and 3%, respectively, whereas in the DF process transmission of lipids for regular and whey buttermilk was higher (8.5% and 4.7%, respectively)</p> <ol style="list-style-type: none"> 1 TMP 4000 kPa and 2000 rpm (with vanes): 56.5% permeate flux decrease with increasing volume reduction ratio (VRR) from 1 to 7.5 2 Maximum dry matter percentage (38%): disk with vanes rotating at 2000 rpm 3 Increase of COD and mean ionic concentration with increasing VRR values at 2000 rpm and both types of disks 4 COD was higher at smooth disks than disks with vanes 	Frappart <i>et al.</i> , 2006
<i>D Constructed wetlands</i>							
14	Dairy parlor wastewater	Treatment with a multiple-phase biological system	-	The system was consisted of an aerated SBR containing activated sludge, followed by a series of constructed wetlands	-	<ol style="list-style-type: none"> 1 SBR: decrease of BOD₅ and COD up to 92.1–96.1% and 86.1–89.5%, respectively 2 Wetlands: reduction of BOD₅ and COD ranging from 70.1 to 81.8% and from 56.6 to 64.5%, respectively 3 Reduction of suspended solids (SS), ammonium, nitrate and phosphorus 	Moir <i>et al.</i> , 2005
15	Dairy wastewater	Treatment in constructed wetlands	CBOD ₅ , SS, temperature, conductivity, pH, DO, FC, NBOD, dissolved humic color	Planted (<i>Schoenoplectus validus</i>) and unplanted gravel-bed wetlands were operated at retention times of 7, 5.5, 3 and 2 days, with in- and outflows sampled	<ol style="list-style-type: none"> 1 CBOD₅, SS, temperature, conductivity, pH, DO, FC: according to methods described by APHA (1989) 2 NBOD: 4.33 times the NH₄-N concentration (Copper, 1986) 3 Dissolved humic color: 	<ol style="list-style-type: none"> 1 CBOD₅ removal up to 76–92% and 60–85% in planted and unplanted constructed wetlands, respectively 2 In planted channels BOD (CBOD₅ + NBOD) removal decreased from 80 to 50%, whereas in unplanted wetlands 	Tanner <i>et al.</i> , 1995a

				bimonthly for 20 months	UV spectrophotometer at 440 nm	BOD removal ranged from 60 to 85% 3 75–80% SS and 90–99% FC removal for planted and unplanted wetlands 4 Dissolved humic color was reduced up to 40% at longer retention times	
16	Dairy wastewater	Treatment in constructed wetlands	Ammonium, nitrate and nitrite N, TKN, TP, DRP	Planted (<i>Schoenoplectus validus</i>) and unplanted gravel-bed wetlands were operated at retention times of 7, 5.5, 3 and 2 days, with in- and outflows sampled bimonthly for 20 months	1 Ammonium: according to method described by Brown (1973) 2 Nitrate and nitrite N: according to method 418C (APHA, 1985) 3 TKN: modified micro Kjeldahl digestion using selenium catalyst 4 TP and DRP (total and dissolved reactive P): according to method described by NAWASCA (1982)	1 TN removal in planted and unplanted channels was 48–75%, and 12–41%, respectively 2 TP removal was 37–74%, and 12–36%, respectively	Tanner <i>et al.</i> , 1995b
17	Dairy wastewater	Use of ecological treatment system (ETS)	Ammonium-nitrogen (NH ₄ -N), nitrite and nitrate, orthophosphate (PO ₄ -P), CBOD, water quality	The wastewater flowed through the anaerobic reactor, anoxic reactor, closed aerobic reactor, planted aerobic reactor, clarifier, subsurface wetland mesocosm, two more planted aerobic reactors and another clarifier and two more subsurface wetland mesocosms, for 20 weeks	1 Ammonium-nitrogen (NH ₄ -N): according to method described by Liao (2001) 2 Nitrite and nitrate (NO _x -N): according to method described by Wendt (1995) 3 Orthophosphate (PO ₄ -P): according to method described by Diamond (1995) 4 CBOD according to 5-day nitrification inhibitor method (Hach <i>et al.</i> , 1997) 5 Water quality analyses: using Standard Methods (APHA, 1989)	1 99% removal of ammonium-nitrogen (NH ₄ -N) and carbonaceous biochemical oxygen demand (CBOD) 2 79% removal of orthophosphate (PO ₄ -P) 3 Nitrate and nitrite were produced with effluent concentration of 0.53 mg/l and removed within the system	Lansing and Martin, 2006

(Continued)

Table 13.4 (Continued)

No	Kind of waste	Treatment	Parameters	Methodology	Quality control methods	Results	References
18	Dairy wastewater	Treatment in a constructed wetland system	Dissolved oxygen, pH, conductivity, temperature, TSS, BOD, total Kjeldahl nitrogen, ammonia, nitrate/nitrite, total phosphorus, ortho-phosphate	The system consisted of two settling basins, two wetland cells planted with <i>Typha latifolia</i> L. and <i>Schoenoplectus tabernaemontani</i> and a vegetated filter strip colonized by <i>Lemna minor</i> L. and <i>Echinochloa crusgalli</i>	<ol style="list-style-type: none"> 1 Dissolved oxygen, pH, conductivity, temperature: by portable meters 2 TSS, BOD, total Kjeldahl nitrogen, ammonia, nitrate/nitrite, total phosphorus, ortho-phosphate: according to Standard Methods (APHA, 1992) 	<ol style="list-style-type: none"> 1 Reduction of total nitrogen (98%), ammonia (56%), total phosphorus (96%), ortho-phosphate (84%), suspended solids (96%), and BOD (97%) 2 Increase of nitrate/nitrite (82%) 	Schaafsma and Baldwin, 1999
<i>E Coagulation/electrocoagulation/flocculation/precipitation</i>							
19	Dairy wastewater	Electro-coagulation	COD, oil-grease	The experiment was conducted in an electrochemical reactor consisting of iron electrodes at 25°C, 0–15 V and 0–3 A	COD and oil-grease: according to Standard Methods for examination of water and wastewater (APHA, 1992)	<ol style="list-style-type: none"> 1 COD and oil-grease removal up to 98% and 99%, respectively 2 The optimum current density, pH and electrolysis time for treating dairy wastewater with COD of 18 300 mg/l and oil-grease of 4570 mg/l were 0.6 mA/cm² and 7 and 1 min, respectively 3 Energy consumption was 0.003 kWh/kg of COD 	Şengil and Özacar, 2006
20	Dairy effluent	Electrochemical oxidation	COD, ammonium nitrogen (NH ₄ -N), ammonium nitrate (NO ₃ -N), chloride ion, hypochloride ion, acetic acid	Membrane filters pretreatment of digested effluent obtained from a full-scale anaerobic digester, followed by anodic oxidation and indirect oxidation using dimensionally stable anode (DSA) and lead dioxide coated titanium (Ti/PbO ₂) as anode and stainless steel as cathode	<ol style="list-style-type: none"> 1 COD: by dichromate method 2 Ammonium nitrogen (NH₄-N): using salicylate reaction 3 Ammonium nitrate (NO₃-N), chloride ion, hypochloride ion and acetic acid: by capillary electrophoresis (CE) system 	<ol style="list-style-type: none"> 1 Higher decreasing rate of NH₄-N at DSA than Ti/PbO₂ anode 2 Higher decreasing rate of COD at Ti/PbO₂ than DSA anode 3 Electrochemical oxidation with DAS: prevention of accumulation of NO₃-N 4 Increase of decreasing rate of NH₄-N with NaCl addition before membrane filtration 5 COD decrease was less effective with NaCl addition before membrane filtration 	Ihara <i>et al.</i> , 2006
21	Dairy manure effluent	Struvite precipitation	COD, VS, NH ₃ -N, TP, TDS, pH	The experiment was carried out in stirred batch reactors at room temperature	COD, VS, NH ₃ -N, TP, TDS, pH: according to Standard Methods (APHA, 1995)	<ol style="list-style-type: none"> 1 Above 95% ammonia (NH₄⁺) removal 2 Ammonia removal achieved 	Uludag-Demirer <i>et al.</i> , 2005

			(21–22°C) by adding Mg ²⁺ in the form of Mg(OH) ₂ and MgCl ₂ ·6H ₂ O		by adding 0.06 M Mg ²⁺ in the effluents from one- and two-phase reactors		
22	Dairy wastewater	Coagulation	Suspended solid, TDS, chloride, sulfate, hardness, FOG, phosphorus, pH, conductivity, turbidity, COD, BOD ₅	Coagulation with inorganic (alum and ferric chloride), polymeric (polyaluminium chloride) and naturally organic (sodium carboxymethyl cellulose, alginic acid and chitosan) coagulants, followed by powdered activated charcoal (PAC) treatment <i>Laboratory-scale experiments:</i> Ultrafiltration (UF) and reverse osmosis (RO) <i>Pilot-scale experiments:</i> Microfiltration (MF) and RO	1 Suspended solid, TDS, chloride, sulfate, hardness, oil and grease content (FOG), and phosphorus: according to Standard Methods (APHA, 1998) 2 pH and conductivity: by pH meter 3 Turbidity: by turbidity-meter 132 4 COD: digestion in a COD reactor, followed by titration with standard ferrous ammonium sulfate 5 BOD ₅ : by dissolved oxygen meter	1 Optimized conditions: 10 mg/l chitosan, 1.5 g/l dosage of PAC, pH 4.0 2 57% total dissolved solids (TDS), 62% COD reduction, color and odor elimination 3 Laboratory-scale experiments: not significant TDS and COD decrease after UF, 90.8–91.8% TDS and 80–91% COD decrease in RO permeate 4 Pilot scale experiments: 95.8% TDS, 98.5% COD and 95.8% BOD removal of RO permeate	Sarkar <i>et al.</i> , 2006
<i>F Bioremediation</i>							
23	Dairy effluent	Polishing by aquatic macrophytes	Physicochemical parameters, total nitrogen (N)	Three aquatic macrophytes (<i>Eichhornia crassipes</i> , <i>Lemna minor</i> and <i>Azolla pinnata</i>) were cultured individually and in combinations and placed in separate aquaria, where each aquarium was filled with dairy effluent	1 Physicochemical analysis: Standard Methods (1995) 2 Total nitrogen (N): by micro-Kjeldahl method	1 Nitrogen (N) removal by <i>E. crassipes</i> , <i>Lemna minor</i> and <i>Azolla pinnata</i> was 71.8%, 62.5% and 60.1%, respectively 2 Phosphorus (P) removal by <i>E. crassipes</i> , <i>Lemna minor</i> and <i>Azolla pinnata</i> was 63.2%, 58.8% and 56.3%, respectively 3 The highest removal of N (78.8%) and P (69.4%) was reported in mixed culture of <i>E. crassipes</i> and <i>L. minor</i>	Tripathi and Upadhyay, 2003
24	Dairy manure	Fermentation	DM, NDF, ADF, ADL, total carbon,	Inoculation with pure culture of either 10% (v/v)	1 DM: by drying at 105°C	1 Production of cellulase with high level of β-glucosidase at	Wen <i>et al.</i> , 2005

(Continued)

Table 13.4 (Continued)

No	Kind of waste	Treatment	Parameters	Methodology	Quality control methods	Results	References
			total nitrogen ammonium, potassium, phosphorus, calcium, magnesium, sodium, sulfur, iron, manganese, zinc, cobalt, copper, glucose concentrations, total cellulose, β -glucosidase	<i>T. reesei</i> (25.5°C and pH 5.76) or 10% (v/v) <i>A. phoenicis</i> (28.2°C and pH 5.14) or mixed culture 10% (v/v) <i>T. reesei</i> and 10% (v/v) <i>A. phoenicis</i> (27°C, pH 5.5)	2 NDF, ADF, ADL: by gravimetric method (Goering and van Soest, 1970) 3 Total carbon and total nitrogen: using automatic combustion 4 Ammonium: by titrimetric method (Eaton <i>et al.</i> , 1995) 5 Potassium, phosphorus, calcium, magnesium, sodium, sulfur, iron, manganese, zinc, cobalt, copper: EPA method 3050/6010 6 Glucose concentrations: using an enzyme assay kit 7 Total cellulose and β -glucosidase activities: according to standard IUPAC procedures	mixed culture of <i>T. reesei</i> and <i>A. phoenicis</i> 2 β -glucosidase and filter paper activity were 0.6 IU/ml and 1.5 FPU/ml, respectively 3 Higher β -glucosidase production than commercial enzyme and commercial enzyme broth of the pure culture of <i>T. reesei</i>	
25	Sugarcane trash and cattle dung	Composting	Organic C, total N, water-soluble C, total C, cellulose, xylanase, protease activities, CO ₂ , changes in microflora, humic substances	A mixture of sugarcane trash and cattle dung (4:1 or 1:1 dry weight) was composted for 14, 30, 45, 60 and 90 days (moisture 60% of water-holding capacity (WHC), 28–30–45°C)	1 Organic C: dry combustion (Nelson and Sommers, 1982) 2 Total N: Kjeldahl method (Bremner and Mulvaney, 1982) 3 Water soluble C: in water extract oven dried and sieved compost was suspended in distilled and shaken for 30 min and filtered 4 Total C: titrimetric method (Kalembasa and Jenkinson, 1973) 5 Cellulase and xylanase activities: by the method of Schinner and Von Mersi (1990) 6 Protease activity: by measuring hydrolysis of	1 Organic carbon and C/N ratio decreased with time 2 Total nitrogen increased with time 3 Maximum enzyme activities for cellulase, xylanase and protease were reported after 30 and 60 days of composting 4 Population of thermophilic and mesophilic bacteria had the highest value at 14 and 30 days of composting, respectively and declined with time 5 Mesophilic population had the highest value at 30 days of composting and decreased with time 6 Thermophilic population reduced during composting	Goyal <i>et al.</i> , 2005

				<p>casein by method of Ladd and Butler (1972)</p> <p>7 CO₂: by trapping the CO₂ in NaOH solution and titrating it with HCl after addition of saturated barium chloride (Garcia <i>et al.</i>, 1992)</p> <p>8 Changes in the microflora: plating on nutrient agar and Martin's rose begal medium and incubation at 30°C and 45°C for mesophilic and thermophilic microorganisms, respectively</p> <p>9 Humic substances: according to method of Kononova (1961)</p>			
26	Dairy wastewater	Fermentation	CO ₂ , biomass, OUR, specific oxygen uptake, SVI, microorganism colony morphology	<p><i>Batch mode experiments:</i> Dairy wastewater (COD 0.5–4 g/l) fed into bioreactor at pH 7, 30°C, 200 rpm</p> <p><i>Continuous mode experiments:</i> Industrial effluent or model effluent consisting of homogenized whole milk (COD 0.5–1.9 g/l) fed into bioreactor at 19–23°C</p>	<p>1 CO₂: with GC</p> <p>2 Biomass: with gravimetric method</p> <p>3 Oxygen uptake rate (OUR): by measuring dissolved oxygen versus time</p> <p>4 Specific oxygen uptake: calculating the ratio between OUR and VSS</p> <p>5 SVI: calculating the ratio between sludge volume and VSS</p> <p>6 Microorganism colony morphology: after 24–48 h of cultivation at 37°C and by BOX-PCR genomic fingerprinting</p>	<p>1 Batch tests: 78% COD removal, CO₂ production 1.1 g per g of COD removed and biomass yield 0.41 g volatile suspended solids (VSS)/g of COD removed</p> <p>2 Continuous tests: 89% COD removal</p>	Loperena <i>et al.</i> , 2006
27	Municipal solid wastes	Composting	Cumulative mass of carbon dioxide, dissolved ammonia	Composting in an aerobic digester operated at 52 ± 2°C (thermophilic temperature) for 47–198 days. Addition of partially composted municipal waste to some runs	<p>1 Cumulative mass of carbon dioxide: by titration</p> <p>2 Dissolved ammonia: by distillation/titration</p>	<p>1 CO₂ emission after addition of partially composted municipal waste to paper or yard or food waste (composted individually): 150–370 g CO₂-C and 2.0–34 g NH₃-N per dry kg of starting material</p>	Komilis and Ham, 2006

(Continued)

Table 13.4 (Continued)

No	Kind of waste	Treatment	Parameters	Methodology	Quality control methods	Results	References
28	Cheese whey	Bioremediation (two strategies)	Organic acids, sugar, ethanol, COD, protein, analysis of exit gas from the bioreactor	<p><i>First strategy:</i> Anaerobic, mesophilic (45°C) first stage, followed by an aerobic, mesophilic (45°C) second stage</p> <p><i>Second strategy:</i> Anaerobic, mesophilic (45°C) first stage, followed by an aerobic, thermophilic (55–65°C) second stage</p>	<ol style="list-style-type: none"> Organic acids, sugar, ethanol: with HPLC COD: with reactor digestion method (Jirka and Carter, 1975) Protein: using a Coomassie protein assay reagent based on the Bradford method Analysis of exit gas from the bioreactor: by mass spectrometer 	<ol style="list-style-type: none"> CO₂ emission of all mixtures: 240–300 g CO₂-C per dry kg of initial substrate, NH₃ production was 0.5–15 g NH₃-N per dry kg of initial substrate Dissolved oxygen (DO): >80% of saturation during aerobic processing, whereas DO >65% of saturation during the thermophilic stage 68% COD decrease during the anaerobic and aerobic stages and 59% soluble protein decline Thermophilic treatment: 62.5% COD and 47.5% soluble protein decline Second strategy: 100% reduction of COD and lactose and 90% decrease in soluble protein 	Kosseva <i>et al.</i> , 2003
<i>G Miscellaneous treatment methods</i>							
29	Dairy manure (fibers)	Acid hydrolysis	NDF, ADF, ADL, ash, mono-sugars, metal elements (calcium, magnesium, sodium and potassium), phosphorus, nitrogen, crude protein, carbon, sulfur, nitrogen, structure changes	Diluted dairy manure to different acid concentrations (65%, 70% and 75%) was used for acid hydrolysis experiments at 100°C for 1 h at four treatment durations (30, 60, 90 and 120 min). Decrystallized manure was subject to acid hydrolysis under two acid concentrations (10% and 12.5%), three levels of temperatures (100, 120 and 135°C) and six reaction times (10, 20, 30, 60, 90, 120, 150, and 180 min)	<ol style="list-style-type: none"> NDF, ADF, ADL and ash: by using Van Soest Fiber Analysis System (Goering and van Soest, 1970) Hemi-cellulose: by the difference of %NDF – %ADF Mono-sugars: with ion chromatograph Metal elements (calcium, magnesium, sodium and potassium): by using atomic absorption Phosphorus, nitrogen and crude protein: by using AOAC method (Association of Official Analytical Chemists, 1990) Carbon, sulfur and nitrogen: by automated combustion 	<ol style="list-style-type: none"> Optimal conditions for decrystallization: 75% acid concentration, 3:5 sample to acid ratio (weight basis), and 30 min reaction time Optimal conditions for acid hydrolysis: 12.5% acid and 10% dry sample at 135°C for 10 min Under optimal conditions: 84% glucose (26 g/l) and 80% hemicellulose-sugars (11 g/l) production 	Liao <i>et al.</i> , 2006

				techniques			
30	Dairy manure	Two-phase anaerobic digestion	COD, VS, NH ₃ -N, TKN, TP, pH	Dairy manure was fed into an acidifying reactor for 26 days (SRT/HRT 10 days, organic loading rate (OLR) 1.19 g COD/l day (1.0 g VS/l day)). The effluent was then fed into a methanogenic reactor for 21 days (same OLR, influent VS concentration 0.91%). For 86 days the two-phase reactor was operated at SRT/HRT of 10 days, at different OLR (2.39–15.06 g COD/l day or 2.0–12.6 g VS/l day, respectively) and influent VS concentrations (1.83–11.5%)	7 Structure changes: by using a scanning electron microscope COD, VS, NH ₃ -N, TKN, TP, and pH: according to Standard Methods (APHA, 1995)	<ol style="list-style-type: none"> Highest biogas production rate: 2.272 l/day at OLR of 7.53 g COD/l day Highest biogas yield: 1.76–1.78 l biogas/g VS added at OLR of 5.97 and 7.53 g COD/l day Biogas production: 50% and 67% higher at OLR of 5.97 and 7.53 g COD/l day, respectively, compared to one-phase reactor (SRT/HRT of 20 days) Two-phase reactor: 30–71% COD and 16–70% VS removal One-phase reactor: 45–77% COD and 36–70% VS decrease (SRT/HRT of 20 days) and 24–50% COD and 16–40% VS decline (at SRT/HRT of 10 days) 	Demir and Chen, 2005
31	Dairy manure	Fixed-film anaerobic digestion	TS, VS, FS, TCOD, pH, alkalinity, EC	Flushed dairy was flowed down to a sand-trap and to a mechanical separator for large fibrous solids removal. The separated wastewater was directed to a sedimentation basin and then into a sampling pit and a storage pond. Pretreated wastewater was pumped to an anaerobic lagoon, where the liquid was irrigated onto cropland	TS, VS, FS, COD-T, pH, alkalinity, and EC: according to Standard Methods (APHA, 1995)	<ol style="list-style-type: none"> Screening and sedimentation: 46.7% total solids (TS), 60.4% volatile solids (VS) and 42.2% total COD removal Higher flushed dairy manure temperatures reduced TS, VS, and total COD removal efficiencies 	Wilkie <i>et al.</i> , 2004
32	Dairy effluent	Lactose adsorption	Lactose	Adsorption was studied at 30°C using aqueous concentrations from 200 to 1000 mg/l	Lactose: by total organic carbon measurement equipment	Very small amount of lactose was adsorbed by the organophilic clay (0.3–0.5%)	Morais <i>et al.</i> , 2005

Biogas/methane/hydrogen production

Biogas production from agricultural biomass is of growing importance because it offers considerable environmental benefits and an additional source of income for farmers (Chynoweth, 2004). However, hydrogen is now considered as one of the alternatives to fossil fuels. It is preferred to biogas or methane because hydrogen is not chemically bound to carbon and, therefore, burning does not contribute to the greenhouse effect or acid rain (Nath and Das, 2004).

Biogas production from farm dairy wastewater treated in an anaerobic waste stabilization pond was developed and applied to an anaerobic pond treating farm dairy waste by McGrath and Mason (2004). The dairy wastewater was fed to a pond, part of a two-stage anaerobic/facultative waste stabilization pond system, and the loading rates were of 0.12 kg (BOD₅)/cow/day and 0.38 kg (VS)/cow/day, the operation time 190 days and the temperature varied between 13 and 15°C for the first 60 days and reached the maximum value of 24°C at day 190. Biogas detection was reported between 137 and 190 days, while the highest biogas volume was reported at day 138 and was 1121. Total biogas production varied from 0.002 to 0.039 m³/m²/day.

The potential of biogas production from maize and dairy cattle manure was investigated by Amon and coworkers (2006). Dairy manure obtained from cattle with various milk yields and feeding intensities and different ripening varieties of maize (*Zea mays* L.) (early, medium, late) were fed into anaerobic batch digesters at 38°C for 60 days. Biogas and methane yield from dairy manure was 208.2–267.7 NI/kg VS and 125.5–166.3 NI CH₄/kg VS, respectively. The maximum methane yield was recorded after anaerobic digestion of whole maize crops, whereas 43–70% less methane per hectare was recovered from digestion of corn cob mix, only corns or maize. In early and medium ripening varieties, methane yield was 5300–8500 Nm³ CH₄/ha, while in late ripening varieties yielded 7100–9000 Nm³ CH₄/ha.

A gasification system, known as MEET (multistaged enthalpy extraction technology), uses high temperature and preheated air as the gasification medium and was fed with dairy cow manure. A flammable raw synthetic gas (syngas) consisting of CO, H₂ and N₂ was produced and inorganic ash residue was extracted either as a molten slag (slagging mode of operation) or as ash (non-slagging or dry-bottom operation), depending on the selected operating temperature of the gasifier. In slagging mode of operation, the temperature ranged from 1350 to 1400°C, while in the non-slagging operation, the temperature was maintained between 800 and 900°C. The results indicated gasification conversion efficiencies of 65–85%, depending on operation mode and syngas utilization for electricity and heat generation, or for other energy needs, thus reducing the operating costs of the farm (Young and Pian, 2003).

Callaghan *et al.* (1999) evaluated the co-digestion of cattle slurries with various solid wastes, such as chicken manure (TS content 7.5% and 15%), food and vegetable waste (TS 9.2%), fish offal (TS 8.7%), dissolved air flotation sludge and brewery sludge. Cattle slurries and solid wastes were placed in batch digesters and mixed at 120 rpm and 35°C. In general, volatile solids (VS) reductions were between 45 and 55%, even though the highest VS removal was 81% and was observed during co-digestion of cattle slurry with chicken manure (TS content 15%). Cumulative

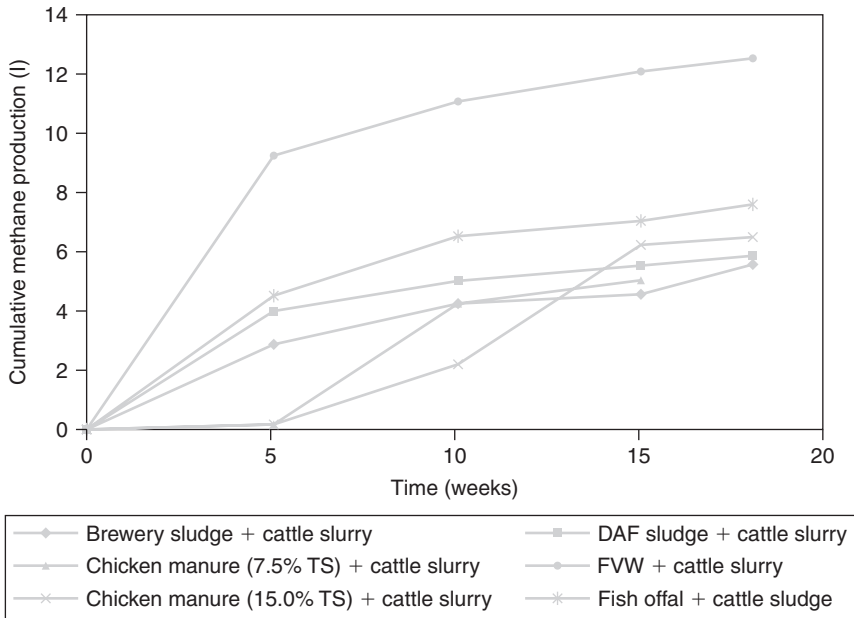

Figure 13.12 Mean cumulative methane production of cattle slurries with various solid wastes (adapted from Callaghan *et al.*, 1999)

methane production of co-digestions with fruit and vegetable waste was the highest of all the other co-digestions (Figure 13.12). The highest specific gas yield was reported in co-digestions of cattle manure and fish offal or brewery sludge (0.38 and 0.31 m^3 CH_4/kg VS removed, respectively), whereas the lowest values were recorded in co-digestion of cattle manure with food and vegetable waste or chicken manure (0.13 – 1.16 m^3 CH_4/kg VS removed). Finally, an increase in N concentration was observed, with the greatest increase reported in digesters fed with chicken manure.

Dairy manure with total solids (TS) concentration 7–8% was screened and then subject to coagulation/flocculation, using calcium oxide (CaO) as coagulant and a cationic polyacrylamide as flocculant, obtaining liquid and solid fractions. The solid fractions contained 75.2% of the initial manure TS, 80.4% of the volatile solids (VS), 58.6% of the total Kjeldahl nitrogen (TKN) and 87.4% of the total phosphorus (TP). On the contrary, the liquid fraction contained 21.8% of the initial manure TS, 17.0% of the VS, 39.5% of the TKN and 10.8% of the TP. For the liquid fraction, the mean percentage of COD that was metabolized by anaerobic microorganisms was 83.7%. The specific methane production for the dairy manure, the screened manure and the liquid fraction were 0.307, 0.371, and 0.6041 NCTP CH_4/g VS, respectively (Table 13.5) (Rico *et al.*, 2007).

Ferchichi *et al.* (2005) studied the influence of initial pH on hydrogen (H_2) production from fresh crude (unskimmed) cheese whey by *Clostridium saccharoperbutyl-acetonicum*. The fermentation process was carried out in a pH range from 5 to 10, at 30°C and at agitation speed 50 rpm. Sugar consumption remained high at 97% at

Table 13.5 Specific methanogenic production (at 35°C) of dairy manure, screened manure and liquid fraction

Days	Specific methanogenic production (l NCTP CH ₄ /g VS)		
	Dairy manure	Screened manure	Liquid fraction
0	0	0	0
10	0.180	0.250	0.600
20	0.280	0.350	0.600
30	0.300	0.371	0.604
40	0.307	0.371	0.604

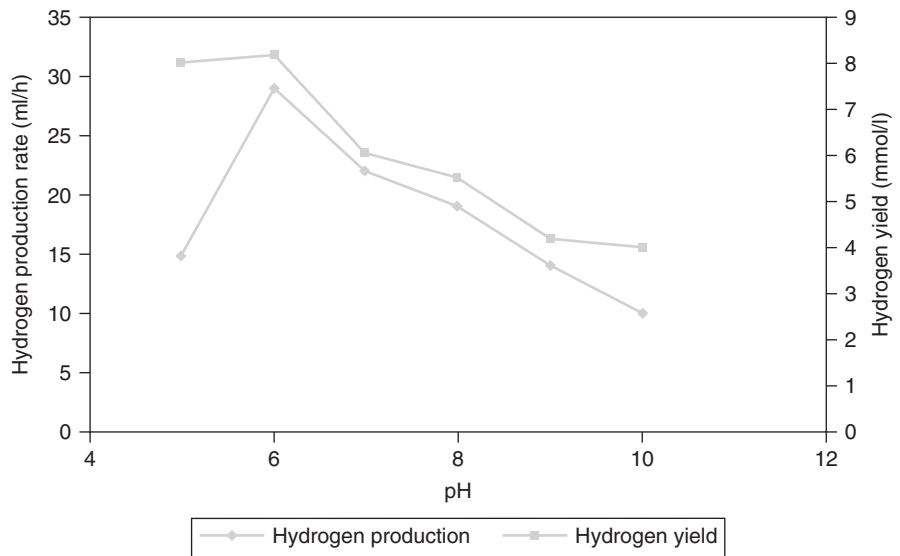
Adapted from Rico *et al.*, 2006**Figure 13.13** Relationship between pH and hydrogen production rate and yield (adapted from Ferchichi *et al.*, 2005)

pH 5–9 and decreased down to 92% at pH 10. The results showed that H₂ production was pH-dependent, while the same trend was observed in H₂ production rate and yield. The highest H₂ production (1432 ml), yield (7.89 mmol/g lactose) and the maximum production rate (47.07 ml/h) were observed at pH 6 (Figure 13.13). The final pH of the culture ranged from 5.5 to 6.1 and increased with initial pH, while shorter fermentation times (50–52 h) were reported at pH 6–8, but outside this range, fermentation times were much longer (62–80 h).

Fertilizer

Composting is a widely used method for disposal of organic wastes. Application of un-composted wastes or non-stabilized compost to land may lead to immobilization

of plant nutrients and cause phytotoxicity (Butler *et al.*, 2001; Fuchs, 2002; Cambardella *et al.*, 2003). Composting converts manure and bedding nutrients into a more stable form, adds humic acid to the soil, increases beneficial soil organisms, improves soil tilth and aeration, reduces raw manure odors and reduces reliance on synthetic fertilizers. Various methods are available to produce compost (<http://cru.cahe.wsu.edu/CEPublications/eb1947b/eb1947b.pdf>). The use of organic manures as amendments to improve soil organic matter level and long-term soil fertility and productivity is gaining importance. The benefits of composted organic wastes to soil structure, fertility, as well as plant growth, have been increasingly emphasized (Chen *et al.*, 1992; Murwira *et al.*, 1995; Esse *et al.*, 2001). Therefore, composting processes have the potential to reduce significantly environmental problems associated with manure management (Carr *et al.*, 1995).

Bol and coworkers (2003) examined the short-term effects of land application of dairy slurry amendment on carbon sequestration and enzyme activities in temperate grassland. Slurry collected from cows fed with either ryegrass (*Lolium perenne* – C3 plant) or maize (*Zea mays* L – C4 plant) silages was applied to soil. The results showed that water-soluble organic carbon (WSOC) content was two to three times higher in the amended soil in comparison to non-amended soil, whereas no significant change in the soil microbial biomass (SMB) carbon content was recorded 4 weeks after the application of slurry. Furthermore, higher urease, cellobiohydrolase, β -N-acetyl-glucosamidase, β -glucosidase and acid phosphatase activities in slurry treated soil were observed.

Fish bioassays on an economically important and widely cultured fish, rohu (*Labeo rohita*), for the evaluation of raw and bioremediated dairy effluent were conducted by Mishra *et al.* (2000). Dairy effluent (0%, 50%, 60%, 70%, 80%, 90% and 100% concentrations) was treated with *Wolffia arrhiza* (pteridophyte) and, after 15 days of bioremediation, the *Wolffia* was removed and the collected effluent was utilized for bioassay at the same concentrations as the raw dairy effluent. Bioassays were performed by exposing test animals to 10%, 20%, 30%, 40%, 50% and 60% concentrations of diluted raw dairy effluent (Figure 13.14). After 96 h of exposure 0%, 30%, 60%, 90%, 100% mortalities were recorded in that order. There were reductions up to 74% in BOD, 72% in COD, 58% in total available nitrogen (TAN) (NH_4^+ -N, NO_2^- -N, NO_3^- -N), and 76% in available phosphorus (TP) (PO_4^{2-} -P) (Figure 13.15). Furthermore, the 96-h LC50 values of raw and treated dairy effluent on *Labeo rohita* were 25.5% and 73.5%, respectively. Bioremediated dairy effluent can be used in aquaculture as a fertilizer with proper dilution.

Straw, two green waste composts (GWC1, GWC2), sawdust, paper sludge and tannic acid were mixed with celery leaves (*Apium graveolens* L.) for nitrogen (N) immobilization from crop residues, while malting sludge, vinasses, molasses and dairy sludge were added to the treatments for immobilized N remineralization. The fastest N immobilization was observed with straw (30.2 mg N/kg), whereas the slowest with tannic acid, sawdust and GWC1 (16.4, 15.9 and 8.0 mg N/kg, respectively). No N immobilization was reported with paper sludge and GWC2. On the other hand, N remineralization was recorded only with a mixture of GWC1 and vinasses (55.4 mg N/kg). Therefore, organic biological wastes (OBW) can be used for nitrate concentration reduction in soil due to the N-release from vegetable crop residues (Chaves *et al.*, 2005).

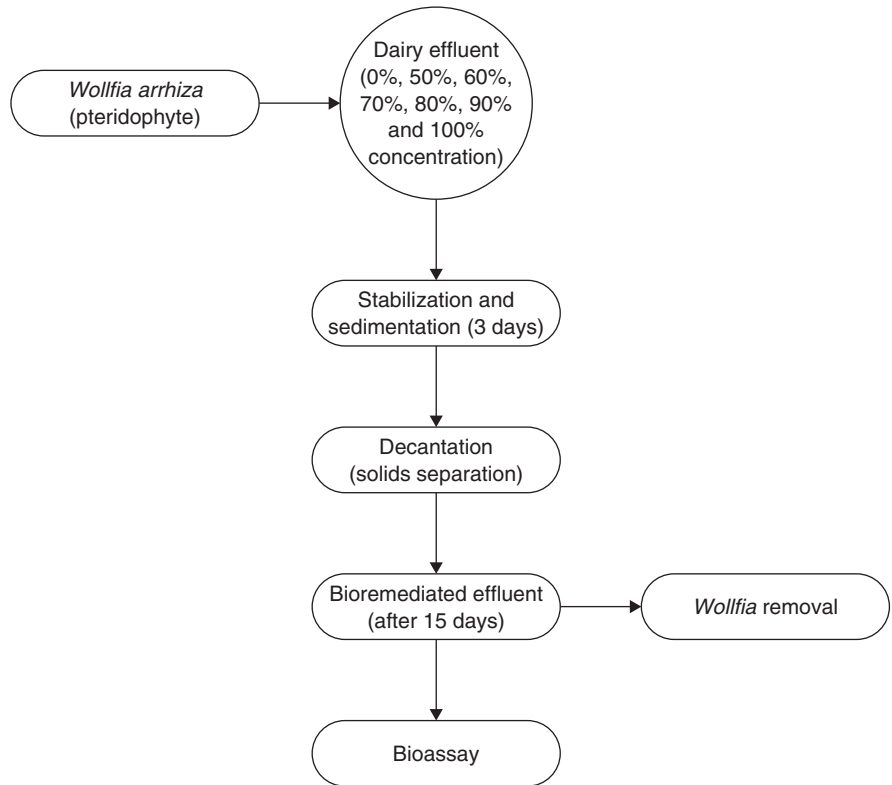

Figure 13.14 Bioremediation of dairy slurry for fish bioassays (adapted from Mishra *et al.*, 2000)

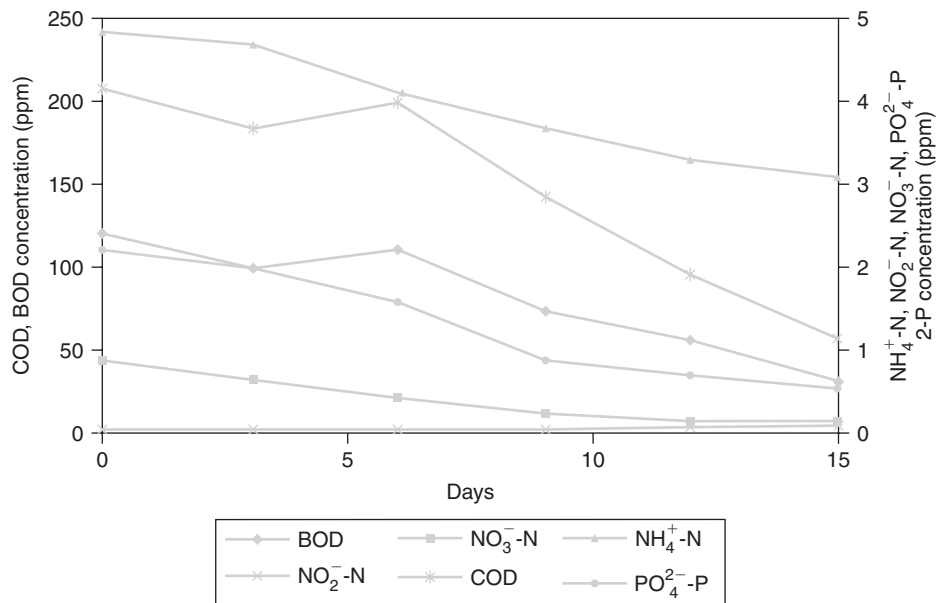

Figure 13.15 Changes in physicochemical parameters of raw undiluted dairy effluent during bioremediation (adapted from Mishra *et al.*, 2000)

The thermophilic aeration of cattle slurry and food industrial by-products was examined by Heinonen-Tanski *et al.* (2005). Cattle slurry alone and a mixture of cattle slurry, whey and/or jam wastes (slurry:whey:jam 45%:27.5%:27.5%; slurry:(whey or jam) 70%:30%) were aerated in a heat-insulated reactor with retention times of 4–5 days. The process started in winter when the ambient temperature ranged from 0 to –21°C and ended in summer at 20°C. The heat energy formed was higher than the electrical energy needed to carry out the aeration, thus indicating that the extra heat could be utilized for preheating the water, which is needed in a farm household and for washing of milking products and the final product could be used as a fertilizer and soil improving compound to increase the organic matter content of soil. Whey waste suited better for co-composting than jam waste but the mixture of whey, jam waste and slurry was optimal for composting.

Sarathchandra *et al.* (2006) examined the potential effects of high carbon dairy factory effluent application on the growth of perennial ryegrass (*Lolium perenne* L.) and soil microorganisms. Ryegrass seedlings were planted in pots and kept in a controlled-environment room at 20°C, with 16 h light/8 h dark. Dairy effluent was added to the pots at three different rates. Shoot samples were harvested from each treatment at 32, 61 and 130 days after the initial effluent addition. After 32 days, dry matter content declined remarkably with increasing effluent rate, whereas at 130 days effluent treated pots had greater shoot dry matter with increasing effluent rate. A decrease in nitrogen and sulfur concentration in shoots was observed in treated pots, in comparison with phosphorus concentration that was greater in treated than untreated pots. Effluent application increased the populations of potentially pathogenic fungi in roots and decreased the diversity and species richness of total fungi. Root pathogens, such as *Fusarium oxysporum*, total *Fusarium* spp. and *Pythium* spp. increased in treated pots, even though after 130 days *Codinaea fertilis* population decreased significantly with effluent treatment.

The potential of utilization of anaerobically digested dairy slurry combined with other wastes was investigated by Tani *et al.* (2006). Grass growth experiments in the field were conducted by applying digested slurry mixed with 1% or 4% (w/w) ground dry chemical extinguishing agents to orchard grass. Furthermore, plant growth experiments in pots were performed by adding raw and digested slurry mixed with 0%, 0.25%, 0.5% and 0.75% finely ground animal bone ash to dent corn. Dry matter yield of orchard grass was largest to plots with 4% chemical extinguishing agents, followed by control plots (only chemical fertilizers, such as ammonium sulfate, super-phosphate and potassium sulfate were applied), plots with 1% chemical agents and plots with original slurry. On the other hand, dry matter yield of dent corn increased with increase in amount of bone ash added to both raw and digested slurry, even though the yield was significantly higher in the digested than the raw slurry plot. Therefore, digested dairy cattle slurry combined with other wastes were converted to unique soil resources and used for application to agricultural land.

Entry and coworkers (2005) investigated the effect of solid dairy manure and compost with and without alum ($\text{Al}_2(\text{SO}_4)_3$) on the survival of indicator bacteria (*Escherichia coli*, *Enterococcus* spp. and fecal coliforms) in 0–10 cm soil depth and on fresh potato skins 1, 7, 14, 28, 179 and 297 days after application. The application of

solid dairy compost or manure to soil did not increase *E. coli*, *Enterococcus* spp. and fecal coliform populations on any day sampled. The addition of solid dairy manure to soil increased *Enterococcus* spp. and fecal coliform populations in potato rhizospheres. However, fresh potato skins had higher *Enterococcus* spp. and fecal coliform numbers when the solid dairy manure was added to soil in comparison with dairy compost, N-P inorganic fertilizer and N fertilizer. After 7, 14, 28, 179 and 297 days of solid dairy waste and compost and alum application, alum did not affect *Enterococcus* spp. and fecal coliform numbers in the soil. *E. coli* was not detected in any soil, fresh potato skin or potato wash water after dairy manure or compost application regardless of alum treatment on any sampling day.

Dairy manure blended with wheat straw or sawdust (mostly *Quercus* spp.) was composted in windrows at 55–70°C for 4 months. The obtained compost was mixed with peat at different proportions (0, 5, 10, 15, 30, 40, 50 and 100% (v/v)) and used as a substrate for cucumber (*Cucumis sativus* L.) seedling emergence and growth. The greatest differences in the dry weight of shoots were reported in mixtures of 70% peat and 30% compost. Dairy manure-wheat straw compost sampled 0, 14 and 28 days inhibited cucumber growth. Shoot dry weight increased when older (dairy manure-wheat straw or dairy manure-sawdust) composts were mixed with peat. Shoot nitrogen (N) concentration increased from 2.4% in fresh dairy-straw compost mix to 4.0% after 3 months of composting. In dairy manure-wheat straw treatments the concentration of all the other nutrients was within the recommended sufficiency range, whereas the calcium concentration was significantly low (0.6–0.8%). On the other hand, in dairy manure-sawdust treatments the concentration of all nutrients was within the recommended sufficiency range, while N concentration remained low (1.5–2.0%) even in mature composts, Ca concentration was significantly low (0.6–0.7%) and Mo concentration reached the sufficiency range (0.4–1.0%) after 84 days of composting (Wang *et al.*, 2004).

Feces and urine of dairy cows with bedding material and straw were composted in windrow piles for 2 months under controlled aeration and moisture conditions. The four treatments examined were as follows: no turning/no watering, no turning/watering, turning/no watering and turning/watering. Compost samples after 1 month (immature compost) and 2 months (mature compost) of composting initiation, were mixed with soil at two different rates, 1.1 g (low rate) or 3.3 g (high rate) composts (dry weight) per 100 g soil, and placed in an incubator at $20 \pm 2^\circ\text{C}$ for 84 days. An increase in inorganic NO_3^- -N accumulation in soils amended with mature compost obtained from all treatments was reported, while soil mineralization was higher at high rates of composts which were turned during composting. Furthermore, inorganic N accumulation did not differ significantly among soils mixed with immature compost obtained from the four treatments. Compost can be used as an N-fertilizer after intensive aeration and moisture management (turning and watering) during composting (Shi *et al.*, 1999).

Dairy manure effluent treatment by algal turf scrubber technology was performed by Pizarro *et al.* (2006). Raw manure from a 1000-cow dairy was mechanically scraped (or flushed with water) and the resultant manure slurry was subjected to solids separation before manure solids composting and treatment of the manure effluent by anaerobic digestion and algal scrubbing. Dried algal biomass was rich in nutrients, which

were concentrated and stabilized, pathogens were eliminated, heavy metal content was below regulatory limits and easily ground for different formulations. The obtained compost was applied to land, whereas the biomass from the algal scrubbers was either used as a feed supplement or organic fertilizer or exported from the farm. The recovered organic fertilizer was equivalent to a commercial organic fertilizer as far as plant mass and nutrient content was concerned. Finally, the total energy produced from a dairy farm with 1000 cows during anaerobic digestion was 10 700 Mcal/day or 3.9×10^6 Mcal/year, and could be utilized for biomass drying, pumping water and repayment of capital investment.

Animal feedstuff

The food processing industry performs reasonably well at finding value in by-product streams, most often as animal feeds, so it is expected that real 'losses' in food processing will be relatively small (Heller and Keoleian, 2003).

The effect of radiation processing on cow manure as an integral part of the safe recycling was determined by Dia El-Din *et al.* (1999). Air-dried cow manure was treated with gamma irradiation at dose rates of 5, 10 and 25 kGy. Short-term feeding experiments were carried out to determine the effect of radiation of cow waste on growth performance of young chicks. Broiler chicks were fed for 6 weeks with control diet, non-irradiated and irradiated manure at 10 and 25 kGy. The thiamine (vitamin B1) content of the irradiated samples was not significantly different from non-irradiated samples. Irradiated manure with 25 kGy gamma rays displayed an increase in concentration of some amino acids (i.e. arginine, threonine, alanine, tyrosine, valine, methionine, etc.) and a decrease in other amino acids (glutamic acid, serine, glucine, histine). Furthermore, the body gain of chicks fed with non-irradiated and irradiated manure at 10 and 25 kGy was less than control diet by 11.8%, 6.8% and 5.6%, respectively. The mean body weight of chicks fed with untreated and irradiated manure at 10 and 25 kGy was less than those fed with control diet by 10.9%, 6.4%, and 5.2%, respectively.

Scerra and colleagues (1999) investigated the potential of growing different strains of *Penicillium* spp. from dairy products on bergamot fruit peel in solid state. Three strains of *P. camemberti* and seven strains of *P. roqueforti*, obtained from commercial samples of cheeses, were inoculated into Petri dishes and incubated at 25°C for 5 days. Spores of each strain of *Penicillium* were inoculated in bergamot fruit peel pieces and incubated at 25°C for 10 days. A significant increase in crude protein, ether extract, gross energy and structural carbohydrates (neutral detergent fiber, acid detergent fiber, hemicellulose, cellulose) was reported. Therefore, citrus fruit peel can be used as an animal feed, due to increased nutritional value by single cell protein.

Vasala *et al.* (2005) looked into the potential of lactic acid production from high salt containing dairy by-products by *Lactobacillus salivarius* ssp. *salicinii* with pretreatment by proteolytic microorganisms. Four proteolytic microorganisms (*Acinetobacter* spp., *Bacillus megaterium*, *Pseudomonas fluorescens* and *Flavobacterium balustinum*) were added to cheese whey (with 3 g/l whey protein content) and lactose mother liquor

(90 g/l lactose, 9 g/l proteins, 30 g/l other solids) and cultivated aerobically at pH 6.0 and 30°C for 40 h. Lactic acid bacteria cultures (*Lactobacillus casei*, *Lactobacillus rhamnosus*, *Lactobacillus pentosus*, *Lactobacillus salivarius* ssp. *salicinius*, *Lactobacillus salivarius* ssp. *salivarius*) were then added to dairy by-products and cultivated at 37°C. Moreover, another fermentation experiment was carried out in batch bioreactors by adding proteolytic enzymes (alcalase and flavorenzyme) instead of inoculating proteolytic microorganisms into dairy by-products at pH >5.5, 30°C for *L. casei* and 40°C for the other strains. *Lactobacillus salivarius* ssp. *salicinius* proved to be the ideal microorganism for fermentation of high salt and lactose by-products from the dairy industry. Moreover, processed dairy waste can be utilized as an animal feed, due to its advantage of being a probiotic organism. Complete conversion of lactose to lactic acid was reported in the presence of proteolytic microorganisms, while the most rapid acid production was recorded with the addition of protease enzymes.

Food industry

The food processing industry has its own demands concerning the safety of foodstuffs it receives from primary production. Production on farms should be the first target of countermeasures for the safety of food. Farms and industry require reliable information on the contamination level in milk, based on measurements, in order to decide whether milk should be used in dairy production or be disposed of as waste (Rantavaara *et al.*, 2005).

The extraction of milk-clotting enzymes from fish stomach mucosa for cheese manufacture would provide an inexpensive alternative to rennet substitutes for domestic use or to export to cheese-producing nations and would become a new food-related industry. Tavares *et al.* (1997) isolated tuna fish gastric proteases using 25% NaCl solution (w/v) at different holding times (0–3 h), prior to the enzyme activation at pH 5.0, that can be used as an alternative to rennet substitutes. However, further studies are required for testing tuna protease as rennet substitute on an industrial scale.

Milk or whey from dairy industry waste was concentrated with vacuum evaporator at 20°C. Raw lactose was obtained on filter-centrifuge or vacuum filter from whey concentrate (45–65% dry weight) and processed by pre-crystallization and purified into lactose. Lactose remaining in the filtrate was purified from whey proteins by ultrafiltration (UF) and diafiltration (DF) (transmembrane pressure of 0.1 MPa, permeate flow rate of 10 ml/min). Permeate can be further separated from monovalent salts with nanofiltration (NF) to obtain minerals and vitamins. Whey concentrates or whey protein concentrates can be utilized both for sweet and salt foodstuffs (emulsions with 30–50% vegetable oil), extraction of vegetables and fruits, instant flours and additives for soups. On the other hand, lactose, minerals and vitamins can be effectively used in dietetic foodstuff for diabetics and hypertensive patients (Ostojic *et al.*, 2005).

Nanofiltration of cottage cheese whey for the recovery of by-products was performed by Nguyen *et al.* (2003). Cottage cheese whey samples were decanted, heated (65°C), filtered through a cheese bag, heated again (65°C, 60 min) for pasteurization

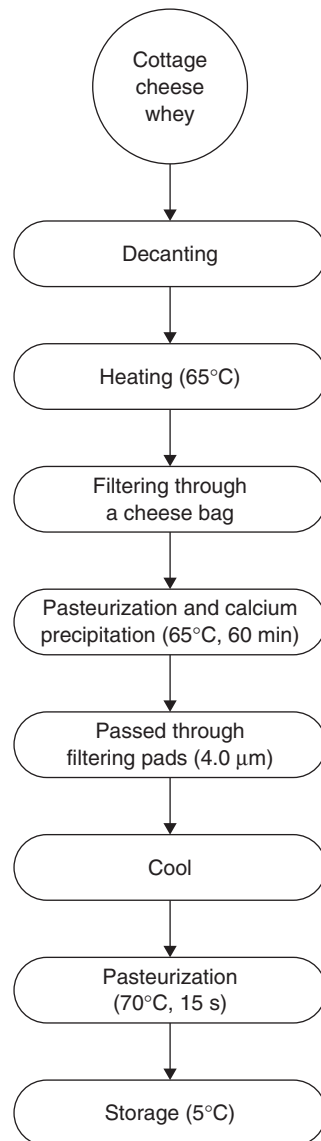

Figure 13.16 Nanofiltration process of cottage cheese whey for recovery of by-products (adapted from Nguyen *et al.*, 2003)

and calcium precipitation, passed through filtering pads (4.0 μm), cooled and were pasteurized (75°C, 15 s) before storage (5°C) (Figure 13.16). An increase in total solids (TS) up to 17.8% and a decrease in sodium concentrate up to 16.3% in the concentrate were recorded. The final concentrate contained significant amounts of fat (1.2%), protein (2.4%) and lactose (19.7%), thus indicating that it can be used in dairy products such as ice-cream and yogurt and can be converted into sweet syrup for use in other products.

Miscellaneous uses

Frozen paste from filleting waste of silver carp (*Hypophthalmichthys molitrix*) was mixed with microbial transglutaminase (3 g/kg), dairy proteins, such as whey protein and sodium caseinate (10 g/kg) and NaCl (0, 10, 20 g/kg) for 2 min at 15°C. The sample was sprayed with commercial regular vegetable oil and immersed in water at 40°C for 1 h and afterwards at 90°C for 20 min. Then, the mixture was placed in a water bath and cooled at 4–5°C for 30 min. Restructured fish products with different levels of salt (0, 1 and 2%) were obtained. The mechanical properties of fish gels increased when the salt level of the samples containing or not dairy proteins increased as well. On the other hand, the mechanical properties of fish gels with 0 and 1% salt content increased only when dairy proteins were utilized for filleting waste treatment. Sodium caseinate had a much greater effect on improving mechanical properties than whey protein, while microbial transglutaminase increased expressible water content (Uresti *et al.*, 2001).

Effluent from the second-stage anaerobic lagoon of a dairy industry was used as a medium for the growth of cyanobacterium *Arthrospira platensis* (blue-green algae) (Lincoln *et al.*, 1996). Algal growth was rapid and uninhibited at ammonia nitrogen (NH₃-N) concentrations lower than 75 mg/l, while growth was inhibited at concentrations higher of 100 mg/l. After 7 days, NH₃-N concentrations decreased from 100 mg/l to less than 1 mg/l, while the maximum removal rate was 24 mg/l/day. Algal biomass production was 70 g/m³/day and half of the dry weight of biomass was edible protein. The potential of production of a protein feed as a by-product of dairy wastewater effluent treatment with cyanobacteria is a great perspective.

A synoptical presentation of various dairy industry waste treatment methods, physicochemical characteristics, applied substrate and final product/uses is summarized in Table 13.6.

Inputs and outputs in dairies

As for many other food processing operations, the main environmental impacts associated with all dairy processing activities are the high consumption of water, the discharge of effluent with high organic loads and the consumption of energy. Noise, odor and solid wastes may also be concerns for some plants (http://www.agrifoodforum.net/publications/guide/d_chp2.pdf).

In the dairy processing industry, water is used principally for cleaning equipment and work areas to maintain hygienic conditions and accounts for a large proportion of total water use. Most water consumed at dairy plants ultimately becomes effluent. Dairy plant effluent is generally treated to some extent on site and then discharged to municipal sewerage systems, if available. Dairy processing effluent includes predominantly milk and milk products which have been lost from the process, as well as detergents and acidic and caustic cleaning agents. Approximately 80% of a dairy plant's energy needs is met by the combustion of fossil fuels (coal, oil or gas) to generate steam and hot water for evaporation and heating processes (http://www.agrifoodforum.net/publications/guide/d_chp0.pdf).

Table 13.6 Dairy industry waste: treatment method and physicochemical characteristics, substrate to be applied and final product uses

No	Substrate to be applied	Treatment method	Physicochemical characteristics	Final product/uses	References
<i>A Biogas/methane/hydrogen production</i>					
1	Dairy waste water	Two-stage anaerobic/facultative waste stabilization pond system (loading rates 0.12 kg (BOD ₅)/cow/day and 0.38 kg (VS)/cow/day, operation time 190 days, 13–15°C the first 60 days, 24°C at day 190)	<ol style="list-style-type: none"> 1 Biogas detection: 137–190 days 2 Biogas production: 0.002–0.039 m³/m²/day 	Biogas production	McGrath and Mason, 2004
2	Maize and dairy cattle manure	Anaerobic batch digestion at 38°C for 60 days	<ol style="list-style-type: none"> 1 Dairy manure biogas and methane yield: 208.2–267.7 NI/kg VS and 125.5–166.3 NI CH₄/kg VS, respectively 2 Methane yield in late ripening maize varieties: 7100–9000 Nm³ CH₄/ha 3 Methane yield in early and medium ripening varieties: 5300–8500 Nm³ CH₄/ha 	Biogas/methane production	Amon <i>et al.</i> , 2006
3	Dairy cow manure	Gasification at high temperatures (slagging mode of operation: 1350–1400°C, non-slagging operation: 800–900°C)	<ol style="list-style-type: none"> 1 Syngas composition: CO, H₂, and N₂ 2 Gasification conversion efficiencies: 65–85% 	Syngas utilization for electricity and heat generation, or for other energy needs, thus reducing the operating costs of the farm	Young and Pian, 2003
4	Cattle slurries	Anaerobic batch digestion cattle slurries and solid wastes at 120 rpm and 35°C	<ol style="list-style-type: none"> 1 VS reduction: 45–55% 2 The highest cumulative methane production: co-digestion of cattle slurry with fruit and vegetable waste 3 Highest specific gas yield: co-digestions of cattle manure and fish offal or brewery sludge (0.38 and 0.31 m³ CH₄/kg VS removed, respectively) 4 Lowest specific gas yield: co-digestion of cattle manure with food and vegetable waste or chicken manure (0.13–1.16 m³ CH₄/kg VS removed) 5 Increase in N concentration 	Methane production	Callaghan <i>et al.</i> , 1999
5	Dairy manure	Coagulation/flocculation (coagulant: calcium oxide (CaO), flocculant: cationic polyacrylamide)	<ol style="list-style-type: none"> 1 Solid fraction: 75.2% TS, 80.4% VS, 58.6% TKN, 87.4% TP 2 Liquid fraction: 21.8% TS, 17.0% VS, 39.5% TKN and 10.8% TP 3 Specific methane production: 0.307 (dairy manure), 0.371 (screened) 	Methane production	Rico <i>et al.</i> , 2007

(Continued)

Table 13.6 (Continued)

No	Substrate to be applied	Treatment method	Physicochemical characteristics	Final product/uses	References
6	Fresh crude (unskimmed) cheese whey	Fermentation by <i>Clostridium saccharoperbutylacetonicum</i> (pH 5–10, 30°C, agitation speed 50 rpm)	manure) and 0.604 (liquid fraction) L NCTP CH ₄ /g VS At pH 6: highest H ₂ production (1432 ml), yield (7.89 mmol/g lactose) and the maximum production rate (47.07 ml/h)	Hydrogen production	Ferchichi <i>et al.</i> , 2005
<i>B Fertilizer</i>					
7	Dairy slurry	Soil application of slurry from cows fed with either ryegrass or maize	1 Higher water-soluble organic carbon (WSOC) content 2 Stable microbial biomass (SMB) carbon content 3 Higher urease, cellobiohydrolase, β -N-acetyl-glucosamidase, β -glucosidase and acid phosphatase activities in soil	Amendment	Bol <i>et al.</i> , 2003
8	Dairy effluent	Bioremediation with <i>Wollfia arrhiza</i> (pteridophyte) for 15 days	Reductions up to 74% in BOD, 72% in COD, 58% in total available nitrogen (TAN) (NH ₄ ⁺ -N, NO ₂ ⁻ -N, NO ₃ ⁻ -N) and 76% in available phosphorus (TP) (PO ₄ ²⁻ -P)	In aquaculture as a fertilizer with proper dilution	Mishra <i>et al.</i> , 2000
9	Dairy sludge	Straw, two green waste composts, sawdust, paper sludge and tannic acid were mixed with celery leaves (<i>Apium graveolens</i> L.) for nitrogen (N) immobilization from crop residues. Malting sludge, vinasses, molasses and dairy sludge were added for immobilized N remineralization	1 Fastest N immobilization: with straw (30.2 mg N/kg) 2 Slowest N immobilization: with tannic acid, sawdust and GWC1 (16.4, 15.9 and 8.0 mg N/kg, respectively) 3 No N immobilization: with paper sludge and GWC2 4 N remineralization: with a mixture of green compost and vinasses (55.4 mg N/kg)	Organic biological waste can be used for nitrate concentration reduction in soil	Chaves <i>et al.</i> , 2005
10	Cattle slurry	Thermophilic aeration of cattle slurry, whey and/or jam wastes in a heat-insulated reactor with retention times of 4–5 days (winter: 0–21°C, summer: 20°C)	Increase of soil organic matter content	1 Heat: for preheating the water, which is needed in a farm household and for washing of milking product 2 Final product: fertilizer and soil improving compound	Heinonen-Tanski <i>et al.</i> , 2005
11	Dairy effluent	Addition of the effluent to pots planted with perennial ryegrass (<i>Lolium perenne</i> L.) seeds (20°C, with 16 h light/8 h dark)	1 Decline of dry matter content with increasing effluent rate (after 32 days of application) and increase of shoot dry matter with increasing effluent rate (after 130 days)	Soil application	Sarathchandra <i>et al.</i> , 2006

			<ol style="list-style-type: none"> 2 Decrease in nitrogen and sulfur concentration in shoots and increase of phosphorus concentration 3 Increase of pathogenic fungi population in roots and decrease of diversity and species richness of total fungi 4 Increase of root pathogens (<i>Fusarium oxysporum</i>, total <i>Fusarium</i> spp. and <i>Pythium</i> spp.) and decrease of <i>Codinaea fertilis</i> (after 130 days) 		
12	Dairy slurry	<ol style="list-style-type: none"> 1 Anaerobically digested dairy slurry mixed with dry chemical extinguishing agents (1% or 4%, w/w/) was added to orchard grass 2 Raw and anaerobically digested slurry mixed with animal bone ash was added to dent corn 	<ol style="list-style-type: none"> 1 Orchard grass: largest dry matter yield with 4% chemical extinguishing agents 2 Dent corn: increased with increase in amount of bone ash 	Application to agricultural land	Tani <i>et al.</i> , 2006
13	Dairy manure or compost	Dairy manure or compost with and without alum ($Al_2(SO_4)_3$) applied to 0–10 cm soil depth and on fresh potato skins	<ol style="list-style-type: none"> 1 Dairy compost or manure: <i>E. coli</i>, <i>Enterococcus</i> spp. and fecal coliform populations remained stable 2 Dairy manure: increase of <i>Enterococcus</i> spp. and fecal coliform populations in potato rhizosphere, higher <i>Enterococcus</i> spp. and fecal coliform populations in fresh potato skins 3 Dairy waste, compost and alum: <i>Enterococcus</i> spp. and fecal coliform numbers remained stable 4 No detection of <i>E. coli</i> 	Soil application	Entry <i>et al.</i> , 2005
14	Dairy manure	Composting in windrows at 55–70°C for 4 months with wheat straw or sawdust (mostly <i>Quercus</i> spp.)	<ol style="list-style-type: none"> 1 Compost sampled 0, 14 and 28 days inhibited cucumber growth 2 Mature composts increased shoot dry weight 3 Fresh dairy-straw compost increased shoot nitrogen (N) concentration from 2.4 to 4.0% 4 Dairy manure-wheat straw treatments: low Ca concentration (0.6–0.8%) 5 Dairy manure-sawdust treatments: low N (1.5–2.0%), Ca (0.6–0.7%) concentration, sufficient Mo concentration (0.4–1.0%) 	Substrate for cucumber (<i>Cucumis sativus</i> L.) seedlings emergence and growth	Wang <i>et al.</i> , 2004

(Continued)

Table 13.6 (Continued)

No	Substrate to be applied	Treatment method	Physicochemical characteristics	Final product/uses	References
15	Feces and urine of dairy cows with bedding material and straw	Composting in windrow piles for 2 months under controlled aeration and moisture conditions (compost treatments: no turning/no watering, no turning/watering, turning/no watering and turning/watering)	<ol style="list-style-type: none"> 1 Increase in inorganic NO_3^--N accumulation in soils amended with mature compost 2 Higher soil mineralization at higher rates of composts (which were turned) added to the soil 3 Inorganic N accumulation did not differ among soils mixed with immature compost 	N-fertilizer	Shi <i>et al.</i> , 1999
16	Dairy manure effluent	Treatment by algal turf scrubber technology	Algal biomass: rich in nutrients, pathogen elimination, low heavy-metal content, easily ground for different formulations	<ol style="list-style-type: none"> 1 Compost: land application 2 Biomass from the algal scrubbers: feed supplement or organic fertilizer or exported from farm 3 Energy: for biomass drying, pumping water and repayment of capital investment 	Pizarro <i>et al.</i> , 2006
<i>C Animal feedstuff</i>					
17	Cow manure	Gamma irradiation at dose rates of 5–25 kGy	<ol style="list-style-type: none"> 1 Body gain of chicks fed with non-irradiated and irradiated manure was less than control diet by 11.8%, 6.8% and 5.6%, respectively 2 Mean body weight of chicks fed with untreated and irradiated manure was less than those fed with control diet by 10.9%, 6.4%, and 5.2%, respectively 	Feedstuff for chicks	Dia El-Din <i>et al.</i> , 1999
18	Dairy products (cheese)	<i>P. camemberti</i> and <i>P. roqueforti</i> strains obtained from dairy products inoculated in bergamot fruit peel pieces and incubated at 25°C for 10 days	Increase in crude protein, ether extract, gross energy and structural carbohydrates (neutral detergent fiber, acid detergent fiber, hemicellulose, cellulose)	Citrus fruit peel can be used as an animal feed	Scerra <i>et al.</i> , 1999
19	Dairy by-products (cheese whey, lactose mother liquor)	<ol style="list-style-type: none"> 1 Addition of four proteolytic microorganisms (pH 6.0, 30°C, 40 h) and lactic acid bacteria cultures (37°C) 2 Addition of proteolytic enzymes (alcalase and flavoenzyme) (pH > 5.5, 30–40°C) 	<ol style="list-style-type: none"> 1 Proteolytic microorganisms: complete conversion of lactose to lactic acid 2 Protease enzymes: fastest acid production 	Animal feed	Vasala <i>et al.</i> , 2005

<i>D Food industry</i>					
20	Fish stomach mucosa	Isolation of tuna fish gastric proteases using 25% NaCl at different holding times (0–3 h), prior to the enzyme activation at pH 5.0	-	Rennet substitutes for cheese manufacture	Tavares <i>et al.</i> , 1997
21	Milk or whey	Concentration by evaporation (20°C), followed by pre-crystallization of raw lactose, lactose purification by ultrafiltration (UF) and diafiltration (DF), permeate separation from monovalent salts by nanofiltration (NF)	-	1 Whey or whey protein concentrates: sweet and salt foodstuff, extraction of vegetables and fruits, instant flours and additives for soups 2 Lactose, minerals and vitamins: in dietetic foodstuff for diabetics and hypertensive patients	Ostojic <i>et al.</i> , 2005
22	Cottage cheese whey	Decantation, heating (65°C), filtration, heating (65°C, 60 min) for pasteurization and calcium precipitation, filtering, cooling pasteurization (75°C, 15 s), storage (5°C)	Concentrate: 17.8% total solids (TS) increase and 16.3% sodium concentrate decrease, 1.2% fat, 2.4% protein, and 19.7% lactose	Concentrate: use in dairy products (ice-cream and yogurt) and conversion into sweet syrup for use in other products	Nguyen <i>et al.</i> , 2003
<i>E Miscellaneous uses</i>					
23	Paste from filleting waste of silver carp (<i>Hypophthalmichthys molitrix</i>)	Mixture with microbial transglutaminase, dairy proteins (whey protein and sodium caseinate) and NaCl (2 min, 15°C), spraying with vegetable oil, immersion in water (40°C 1 h, 90°C 20 min)	Salt levels: 0–2%	Increase in fish mechanical properties	Uresti <i>et al.</i> , 2001
24	Dairy effluent	Second-stage anaerobic lagoon treatment. Used as a medium for cyanobacterium <i>Arthrospira platensis</i> growth	1 Rapid and uninhibited algal growth: at nitrogen (NH ₃ -N) concentrations <75 mg/l 2 Algal growth inhibition: at NH ₃ -N concentrations >100 mg/l 3 Reduction of NH ₃ -N concentrations 100 mg/l to less than 1 mg/l (after 7 days) 4 Maximum removal rate: 24 mg/l/day 5 Algal biomass production: 70 g/m ³ /day	1 Medium for the growth of cyanobacterium <i>Arthrospira platensis</i> 2 Production of a protein feed	Lincoln <i>et al.</i> , 1996

Table 13.7 Inputs and outputs in the dairy industry

Nutrient balance on farm	Inputs						Outputs					
	Conventional farm (kg/ha)			Organic farm (kg/ha)			Conventional farm (kg/ha)			Organic farm (kg/ha)		
	N	P	K	N	P	K	N	P	K	N	P	K
Feed and seeds	134	19.8	46	29	5.2	9						
Products							47	9.5	14	20	4.1	6
Fertilizers	86			0								
N-fixation	15			46								
N-deposition	10			85								
Nutrient surplus							198	10.3	32	65	1.1	3
<i>Milk production process</i>												
Water (l)	4.4											
Electricity (kWh)	0.0463											
Packaged milk (l)							1					
Cream (g)							22.3					
Solid (combustion) waste (g)							2.2					
<i>Emissions to air</i>												
SO ₂ (g)							0.2					
NO ₂ (g)							3.5					
CO (g)							3.8					
<i>Emissions to water</i>												
1 Wastewater (l)							0.2					
COD (g/L)							0.02					
TSS (g/L)							0.02					
<i>Emissions to soil</i>												
1 Sludge (l)							0.05					
Fe (mg/l)							12.9					
Cr (mg/l)							0.38					
Hg (mg/l)							0.008					
Zn (mg/l)							2.9					
<i>Cleaning</i>												
							Water consumption (l per cleaning)			Energy consumption (kWh per cleaning)		
Conventional alkaline/acidic cleaning							1000			110		
One-phase alkaline cleaning							1000			75		
Enzyme-based cleaning							900			65		
pH-2 method							900			85		

Adapted from Cederberg and Mattsson, 2000; Eide *et al.*, 2003; [**13.6] Hospido *et al.*, 2003

Hardly any solid waste is produced by the dairy industry. The main solid wastes produced by the dairy industry are packing material (paperboard cartons, plastic containers, etc.) and sludge resulting from wastewater purification (<http://www.fao.org/WAIRDOCS/LEAD/X6114E/x6114e06.htm#4.%20DAIRY%20INDUSTRY>; <http://www.fao.org/WAIRDOCS/LEAD/X6114E/x6114e07.htm#b3-5.3.%20Treatment%20of%20wastewater>).

Emissions to air from dairy processing plants are triggered by the high levels of energy consumption necessary for production (pasteurization, sterilization, drying etc.). Air pollutants, including oxides of nitrogen and sulfur and suspended particulate matter, are formed from the combustion of fossil fuels, which are used to produce both these energy sources. For operations requiring the use of refrigeration systems based on chlorofluorocarbons (CFCs), the release of these gases to the atmosphere is an important environmental consideration, since CFCs are recognized to be a cause of ozone depletion in the atmosphere (http://www.agrifood-forum.net/publications/guide/d_chp2.pdf).

The principal causes of continuous noise include air discharges from drier stacks, heater fans, air supply fans, ventilation, boilers, pumps, cooling towers, refrigeration units and aerators on aerated lagoons. Noisy operations at dairy plants also include milk drying, which requires high airflows, and the movements of transport vehicles to and from the site ([http://epanote2.epa.vic.gov.au/.../2f1c2625731746aa4a256ce90001cbb5/455a88b76f16a8254a2565fc0008e51b/\\$FILE/570.pdf](http://epanote2.epa.vic.gov.au/.../2f1c2625731746aa4a256ce90001cbb5/455a88b76f16a8254a2565fc0008e51b/$FILE/570.pdf)).

Odors in and around milk processing plants come from the biological decomposition of milk derived organic matter, generally found in wastewater. Often these odors are due to poor housekeeping, overloaded or improperly run wastewater treatment and disposal facilities and prolonged storage of strong wastes such as whey. Particle emissions are caused either by combustion of solid or liquid fuel or, more often, spray drying of milk and whey ([http://epanote2.epa.vic.gov.au/.../2f1c2625731746aa4a256ce90001cbb5/455a88b76f16a8254a2565fc0008e51b/\\$FILE/570.pdf](http://epanote2.epa.vic.gov.au/.../2f1c2625731746aa4a256ce90001cbb5/455a88b76f16a8254a2565fc0008e51b/$FILE/570.pdf)).

Hazardous wastes consist of oily sludge from gearboxes of moving machines, laboratory waste, cooling agents, oily paper filters, batteries, paint cans etc. (http://www.agrifood-forum.net/publications/guide/d_chp2.pdf).

Inputs and outputs of various dairy industry processes are summarized in Table 13.7.

References

Scientific references

- Al-Mutairi, N.Z., Hamoda, M.F. and Al-Ghusain, I. (2004). Coagulant selection and sludge conditioning in a slaughterhouse wastewater treatment plant. *Bioresource Technol* **95**, 115–119.
- Amon, T., Amon, B., Kryvoruchko, V., Zollitsch, W., Mayer, K. and Gruber, L. (2006). Biogas production from maize and dairy cattle manure. Influence of biomass composition on the methane yield. *Agricult Ecosyst Environ* **118**(1–4), 173–182.

- Anderson, G.K. and Yang, G. (1992). Determination of bicarbonate and total volatile acid concentration in anaerobic digesters using a simple titration. *Water Environ Res* **64**, 53–59.
- AOAC (1996a). Fat in dried milk. In *Official methods of analysis*, 16th edn (P. Cunliffe, ed.), Vol. II. AOAC, Maryland.
- AOAC (1996b). Phosphorus in dried milk: colorimetric procedure. In *Official methods of analysis*, 16th edn (P. Cunliffe, ed.), Vol. II. AOAC, Maryland.
- APHA (1985). *Standard methods for the examination of water and wastewater*, 14th edn. American Public Health Association, Washington, DC.
- APHA (1989). *Standard methods for the examination of water and wastewater*, 17th edn. American Public Health Association, Washington, DC.
- APHA (1992). *Standard methods for the examination of water and wastewater*, 18th edn. American Public Health Association, Washington, DC.
- APHA (1998). Standard methods for the examination of water. In *Wastewaters*, 20th edn (M.C. Rand, A.R. Greenberg and M.J. Taras, eds). American Public Health Association, Washington, DC.
- APHA, AWWA, WEF (1985). *Standard methods*, 16th edn. American Public Health Association, Washington, DC.
- APHA, AWWA, WEF (1995). *Standard methods for examination of wastes and wastewater*, 19th edn. American Public Health Association, Washington, DC.
- Argellier, J. and Pannuzzo, S. (1999). TIA Technical Document, Bollene, France.
- Arvanitoyannis, I.S. and Giakoundis, A. (2006). Current strategies for dairy waste management: a review. *Crit Rev Food Sci Nutr* **46**(5), 379–390.
- Asano, T. and Levine, A.D. (1996). Wastewater reclamation, recycling and re-use: past present and future. *Water Sci Technol* **33**(10–11), 1–14.
- Association of Official Analytical Chemists (1990). *Official methods of analysis*, 15th edn, Vol. 1. AOAC, Arlington.
- Bae, T.H., Han, S.S. and Tak, T.M. (2003). Membrane sequencing batch reactor system for the treatment of dairy industry wastewater. *Process Biochem* **39**, 221–231.
- Balanec, B., Vourch, M., Rabiller-Baudry, M. and Chaufer, B. (2005). Comparative study of different nanofiltration and reverse osmosis membranes for dairy effluent treatment by dead-end filtration. *Separat Purificat Technol* **42**, 195–200.
- Basset-Mens, C. and Van der Werf, H.M.G. (2005). Scenario-based environmental assessment of farming systems: the case of pig production in France. *Agricult Ecosyst Environ* **105**(1–2), 127–144.
- Berkhout, F. and Smith, D. (1999). Products and the environment: an integrated approach to policy. *Eur Environ* **9**, 174–185.
- Blanchard, B.D. (1991). *Dairy Food Environ Sanita* **11**(9), 494.
- Bol, R., Kandeler, E., Amelung, W. *et al.* (2003). Short-term effects of dairy slurry amendment on carbon sequestration and enzyme activities in a temperate grassland. *Soil Biol Biochem* **35**, 1411–1421.
- Bremner, J.M. and Mulvaney, C.S. (1982). Nitrogen total. In *Methods of Soil Analysis, Part 2* (A.L. Page, R.H. Miller and D.R. Keeney, eds), pp. 371–378. American Society of Agronomists, Madison, USA.
- Brown, M.W. (1973). A highly sensitive automated technique for the determination of ammonium nitrogen. *J Sci Fed Agricult* **24**, 1119–1123.

- Butler, T.A., Sikora, L.J., Steinhilber, P.M. and Douglass, L.W. (2001). Compost age and sample storage effects on maturity indicators of biosolids compost. *J Environ Qual* **30**, 2141–2148.
- Callaghan, F.J., Wase, D.A.J., Thayanithy, K. and Forster, C.F. (1999). Co-digestion of waste organic solids: batch studies. *Bioresource Technol* **67**, 117–122.
- Cambardella, C.A., Richard, T.L. and Russell, A. (2003). Compost mineralisation in soil as a function of composting process conditions. *Eur J Soil Bio* **39**, 117–127.
- Carr, L., Grover, R., Smith, B., Richard, T. and Halbach, T. (1995). Commercial and on-farm production and marketing of animal waste compost products. *Animal waste and the land–water interface*, pp. 485–492. Lewis Publishers, Boca Raton.
- Carta-Escobar, F., Pereda-Marin, J., Álvarez-Mateos, P., Romero-Guzmán, F., Durán-Barrantes, M.M. and Barriga-Mateos, F. (2004). Aerobic purification of dairy wastewater in batch reactors: kinetic study of the influence of a pre-storage stage without aeration in the degradation of organic matter and ammonium consumption by nitrification. *Process Biochem* **40**, 549–556.
- Cederberg, C. and Dalerius, K. (2001). *Life cycle assessment of pig meat*, pp. 15–42. Naturresursforum Landstinget Halland, Sweden.
- Cederberg, C. and Mattsson, B. (2000). Life cycle assessment of milk production – a comparison of conventional and organic farming. *J Cleaner Product* **8**, 49–60.
- Chaves, B., De Neve, S., Boeckx, P., Van Cleemput, O. and Hofman, G. (2005). Screening organic biological wastes for their potential to manipulate the N release from N-rich vegetable crop residues in soil. *Agricult Ecosyst Environ* **111**, 81–92.
- Chen, X., Chen, G. and Yue, P.L. (2000). Separation of pollutants from restaurant wastewater by electrocoagulation. *Separat Purificat Technol* **19**, 65–76.
- Chen, Y., Inbar, Y. and Hadar, Y. (1992). Composted residues reduce pest and pesticide use. *Biocycle* **6**, 48–51.
- Chynoweth, D.P. (2004). Biomethane from energy crops and organic wastes. In *Anaerobic Digestion 2004. Anaerobic Bioconversion ... answer for Sustainability, Proceedings 10th World Congress*, Vol. 1 (International Water Association, eds), pp. 525–530. Montreal, Canada.
- Cooper, A.B. (1986). Developing management guidelines for river nitrogenous oxygen demand. *J Water Pollut Control Fed* **58**, 845–852.
- Crook, J. and Surampalli, R.Y. (1996). Water reclamation and re-use criteria in the US. *Water Sci Technol* **33**(10–11), 451–462.
- DAH&D (2003). Department of Animal Husbandry and Dairy, Ministry of Agriculture, Government of India, information posted on www.dairy.com.
- Danalewich, J.R., Papagiannis, T.G., Belyea, R.L., Tumbleson, M.E. and Raskin, E. (1998). Characterisation of dairy waste streams, current treatment practices and potential for biological nutrient removal. *Water Res* **32**(12), 3555–3568.
- de Boer, I. (2003). Environmental impact assessment of conventional and organic milk production. *Livestock Product Sci* **80**, 69–77.
- Delbeke, R. (1981). *Milchwissenschaft* **36**(11), 669.
- Demirel, B., Yenigun, O. and Onay, T.T. (2005). Anaerobic treatment of dairy wastewaters: a review. *Process Biochem* **40**, 2583–2595.

- Demirer, G.N. and Chen, S. (2005). Two-phase anaerobic digestion of unscreened dairy manure. *Process Biochem* **40**, 3542–3549.
- Dia El-Din, H., Faraga, M. and Mohamed, F.A. (1999). Effect of radiation processing as an integral part of the safe recycling animal waste. *Anim Feed Sci Technol* **77**, 267–280.
- Diamond, D. (1995). Determination of orthophosphate in water by flow injection analysis colorimetry. QuickChem® Method 10-115-01-1-A. Revised by A. Sardina, 2000. Lachat Instruments, Loveland.
- Dilallo, R. and Albertson, O.E. (1961). Estimation of volatile fatty acids by direct titration. *J Water Pollut Control Fed* **33**, 556.
- Dugba, P.N. and Zhang, R. (1999). Treatment of dairy wastewater with two-stage anaerobic sequencing batch reactor systems-thermophilic versus mesophilic operations. *Bioresource Technol* **68**, 225–233.
- Eaton, A.D., Clesceri, L.S. and Greengerg, A.E. (1995). *Standard methods for the examination of water and wastewater*, 19th edn. American Public Health Association, Washington, DC.
- Entry, J.A., Leytem, A.B. and Verwey, S. (2005). Influence of solid dairy manure and compost with and without alum on survival of indicator bacteria in soil and on potato. *Environ Pollut* **138**, 212–218.
- Esse, P.C., Buerkert, A., Hiernaux, P. and Assa, A. (2001). Decomposition of and nutrient release from ruminant manure on acid sandy soils in the Sahelian zone of Niger, West Africa. *Agric Ecosyst Environ* **83**, 55–63.
- Fallowfield, H.J. and Garrett, M.K. (1985). The treatment of wastes by algal culture. *J Appl Bacteriol* **59**, 187–205.
- Felice, B. and Scioli de, D. (1994). Use of crude whey by *Kluyveromyces marxianus* and by *Yarrowia lipolytica* to reduce pollution of effluents. *Ann Microbiol Enzymol (Italy)* **44**, 65–72.
- Feofanov, Y.A. and Litmanova, N.L. (2001). Mechanism of coagulation purification of wastewater with aluminum oxochloride. *Russ J Appl Chem* **74**, 344–346.
- Ferchichi, M., Crabbe, E., Gil, G.-H., Hintz, W. and Almadidy, A. (2005). Influence of initial pH on hydrogen production from cheese whey. *J Biotechnol* **120**, 402–409.
- Frappart, M., Akoum, O., Ding, L.H. and Jaffrin, M.Y. (2006). Treatment of dairy process waters modelled by diluted milk using dynamic nanofiltration with a rotating disk module. *J Membr Sci* (in press).
- Fuchs, J.G. (2002). Practical use of quality compost for plant health and vitality improvement. In *Microbiology of composting* (H. Insam, N. Riddech and S. Klammer, eds), pp. 435–444. Springer Verlag, Heidelberg.
- Garcia, C., Hernandez, T., Costa, F. and Ayuso, M. (1992). Evaluation of the maturity of municipal waste compost using simple chemical parameters. *Commun Soil Sci Plant Anal* **23**, 1501–1512.
- Goering, H.K. and van Soest, P.J. (1970). Forage fibre analysis (apparatus, reagent, procedures and some application). In *Agricultural Handbook No. 379*, pp. 1–20. Agricultural Research Service – United States Department of Agriculture, Washington DC.
- Goyal, S., Dhull, S.K. and Kapoor, K.K. (2005). Chemical and biological changes during composting of different organic wastes and assessment of compost maturity. *Bioresource Technol* **96**, 1584–1591.

- Haas, G., Wetterich, F. and Kopke, U. (2001). Comparing intensive, extensified and organic grassland farming in southern Germany by process life cycle assessment. *Agricult Ecosyst Environ* **83**, 43–53.
- Hach, C.C., Robert, K.L. Jr and Gibbs, C.R. (1997). Introduction to biochemical oxygen demand. Technical Information Series: Booklet No. 7. Hach Company, USA.
- Hammer, D.A. (1989) *Constructed wetlands for wastewater treatment: municipal, industrial, and agricultural*. Lewis Publishers, Chelsea.
- Haridas, A., Suresh, S., Chitra, K.R. and Manila, V.B. (2005). The buoyant filter bioreactor: a high-rate anaerobic reactor for complex wastewater-process dynamics with dairy effluent. *Water Res* **39**, 993–1004.
- Hayashi, H., Kamiki, T., Sato, S. and Ishioka, Y. (1984). Experiments on the removal of nitrogen and phosphorus from dairy effluent. *Bull Int Dairy Fed* **184**, 28.
- Heinonen-Tanski, H., Kiuru, T., Ruuskanen, J., Korhonen, K., Koivunen, J. and Ruokojärvi, A. (2005). Thermophilic aeration of cattle slurry with whey and/or jam wastes. *Bioresource Technol* **96**, 247–252.
- Heller, M.C. and Keoleian, G.A. (2003). Assessing the sustainability of the US food system: a life cycle perspective. *Agricult Syst* **76**, 1007–1041.
- Hermanowicz, S.W. and Asano, T. (1999). Abel Wolman's 'The Metabolism of Cities' revisited: a case for water recycling and reuse. *Water Sci Technol* **40**(4–5), 29–36.
- Hospido, A., Moreira, M.T. and Feijoo, G. (2003). Simplified life cycle assessment of galician milk production. *Int Dairy J* **13**, 783–796.
- Ihara, I., Umetsu, K., Kanamura, K. and Watanabe, T. (2006). Electrochemical oxidation of the effluent from anaerobic digestion of dairy manure. *Bioresource Technol* **97**, 1360–1364.
- Jirka, A.M. and Carter, M.J. (1975). Micro semi-automated analysis of surface and wastewaters for chemical oxygen demand. *Anal Chem* **47**, 1397–1403.
- Kalembasa, S.J. and Jenkinson, D.S. (1973). A comparative study of titrimetric and gravimetric methods for the determination of organic carbon in soil. *J Sci Food Agric* **24**, 1085–1090.
- Kis, L. (1993). The actual questions of environmental protection in the Hungarian dairy industry. The utilisation of waste (materials) – Part 1. *Tejipar* **43**, 9–13.
- Kis, L. and Ujhelyi, S. (1988). Present state of environmental control in the Hungarian dairy industry and future tasks. *Tejipar* **37**, 71–73.
- Komilis, D.P. and Ham, R.K. (2006). Carbon dioxide and ammonia emissions during composting of mixed paper, yard waste and food waste. *Waste Manage* **26**, 62–70.
- Kononova, M.M. (1961). *Soil organic matter*. Pergamon Press, Oxford.
- Kosseva, M.R., Kent, C.A. and Lloyd, D.R. (2003). Thermophilic bioremediation strategies for a dairy waste. *Biochem Engin J* **15**, 125–130.
- Koyuncu, I., Turan, M., Topacik, D. and Ates, A. (2000). Application of low pressure nanofiltration membranes for the recovery and reuse of dairy industry effluents. *Water Sci Technol* **41**(1), 213–221.
- Ladd, J.N. and Butler, J.H.A. (1972). Short-term assay of soil proteolytic enzyme activities using proteins and dipeptide derivatives as substrates. *Soil Biol Biochem* **4**, 19–39.

- Lansing, S.L. and Martin, J.F. (2006). Use of an ecological treatment system (ETS) for removal of nutrients from dairy wastewater. *Ecol Engin* (in press).
- Liao, N. (2001). Determination of ammonia by flow injection analysis. QuickChem® Method 10-107-06-1-J. Lachat Instruments, Loveland.
- Liao, W., Liu, Y., Liu, C., Wen, Z. and Chen, S. (2006). Acid hydrolysis of Wbers from dairy manure. *Bioresource Technol* **97**, 1687–1695.
- Lincoln, E.P., Wilkie, A.C. and French, B.T. (1996). Cyanobacterial process for renovating dairy wastewater. *Biomass Bioenergy* **10**(1), 63–68.
- Loperena, L., Ferrari, M.D., Saravia, V. *et al.* (2006). Performance of a commercial inoculum for the aerobic biodegradation of a high fat content dairy wastewater. *Bioresource Technol* (in press).
- Luostarinen, S.A. and Rintala, J.A. (2005). Anaerobic on-site treatment of black water and dairy parlour wastewater in UASB-septic tanks at low temperatures. *Water Res* **39**, 436–448.
- Marshall, R.T. (1992). *Standard methods for the examination of dairy products*, 16th edn. American Public Health Association, Washington, DC.
- Mateos, F.-L., Ortubia, M.-G. and Lajusticia, J.F.-M. (1986). Treatment of waste from dairies. *Aliment Equiposy Technol* **5**, 81–90.
- Mavrov, V., Chmiel, H. and Belieres, E. (2001). *Desalination* **138**, 65–69.
- McGrath, R.J. and Mason, I.G. (2004). An observation for the assessment of biogas production from an anaerobic waste stabilisation pond treating dairy farm wastewater. *Biosys Eng* **87**(4), 471–478.
- Mehadia, N. and Ingle, A.O. (1995). Production of Spirulina as single cell protein on the effluents of anaerobic digesters treating dairy wastewater. Natl. Symp. Front. Appl. Env. Microbiol., Cochin University of Science and Technology, Cochin, 15.
- Mishra, S., Barik, S.K., Ayyappan, S. and Mohapatra, B.C. (2000). Fish bioassays for evaluation of raw and bioremediated dairy effluent. *Bioresource Technol* **72**, 213–218.
- Moir, S.E., Svoboda, I., Sym, G., Clark, J., McGechan, M.B. and Castle, K. (2005). An experimental plant for testing methods of treating dilute farm effluents and dirty water. *Biosyst Engin* **90**(3), 349–355.
- Morais, L.C., Dweck, J., Valenzuela-Diaz, F.R. and Büchler, P.M. (2005). Characterisation of lactose and derived products in dairy product industry effluents processing. *J Therm Anal Calorim* **82**, 315–318.
- Morin, P., Pouliot, Y. and Jimenez-Flores, R. (2006). A comparative study of the fractionation of regular buttermilk and whey buttermilk by microfiltration. *J Food Engin* **77**, 521–528.
- Mulder, S.J., Nieuwenhof, F.F.J. and Sikkema, P. (1982). Aerobic pretreatment of dairy effluent on an industrial scale. *Voeding Middelren Technol* **15**, 50–53.
- Muller, L.G. (1959). Use of dinitrosalicylic acid reagent for determination of reducing sugar. *Analyt Chem* **31**(3), 426–428.
- Murwira, K.H., Swift, M.J. and Frost, P.G.H. (1995). Manure as a key resource in sustainable agriculture. In *Livestock and sustainable nutrient cycling in mixed farming of sub-saharan africa* (J.M. Powell, S. Fernandez-Rivera, T.O. Williams and C. Renard, eds), pp. 131–148. International Livestock Centre for Africa (II C.A.) Addis Ababa.
- Nadais, H., Capela, I., Arroja, L. and Duarte, A. (2005). Optimum cycle time for intermittent UASB reactors treating dairy wastewater. *Water Res* **39**, 1511–1518.

- Nath, K. and Das, D. (2004). Improvement of fermentative hydrogen production: various approaches. *Appl Microbiol Biotechnol* **65**, 520–529.
- Nelson, D.W. and Sommers, L.E. (1982). Total carbon, organic carbon and organic matter. In *Methods of soil analysis Part II* (A.L. Page, ed.), pp. 539–579. American Society of Agronomers, Madison.
- Nguyen, M., Reynolds, N. and Vigneswaran, S. (2003). By-product recovery from cottage cheese production by nanofiltration. *J Cleaner Product* **11**, 803–807.
- Novalin, S., Neuhaus, W. and Kulbe, K.D. (2005). A new innovative process to produce lactose-reduced skim milk. *J Biotechnol* **119**, 212–218.
- NWASCA (1982). Physical and chemical methods for water quality analysis. Water and Soil Miscellaneous Publication No. 38, National Water and Soil Conservation Authority, Ministry of Works and Development, Wellington.
- Ostojic, S., Pavlovic, M., Zivic, M. *et al.* (2005). Processing of whey from dairy industry waste. *Environ Chem Lett* **3**, 29–32.
- Pereira, C.D., Diaz, O. and Cobos, A. (2002). Valorisation of by-products from ovine cheese manufacture: clarification by thermocalcic precipitation/microfiltration before ultrafiltration. *Int Dairy J* **12**, 773–783.
- Petzelbauer, I., Nidetzky, B., Haltrich, D. and Kulbe, K.D. (1999). Development of an ultra-high-temperature process for the enzymatic hydrolysis of lactose. I. The properties of two thermostable betaglycosidases. *Biotechnol Bioengin* **64**(3), 322–332.
- Pizarro, C., Mulbry, W., Blersch, D. and Kangas, P. (2006). An economic assessment of algal turf scrubber technology for treatment of dairy manure effluent. *Ecol Engin* **26**, 321–327.
- Poompavai, S. (2002). Treatment of different industry wastewaters. MPhil thesis, Pondicherry University, Pondicherry.
- Ramasamy, E.V. and Abbasi, S.A. (2000). Energy recovery from dairy waste-waters: impacts of biofilm support systems on anaerobic CST reactors. *Appl Energy* **65**, 91–98.
- Ramasamy, E.V., Gajalakshmi, S., Sanjeevi, R., Jithesh, M.N. and Abbasi, S.A. (2004). Feasibility studies on the treatment of dairy wastewaters with upflow anaerobic sludge blanket reactors. *Bioresource Technol* **93**, 209–212.
- Rantavaara, A., Wallin, H., Hasunen, K. *et al.* (2005). Finnish stakeholder engagement in the restoration of a radioactively contaminated food supply chain. *J Environ Radioactiv* **83**, 305–317.
- Rico, J.L., Garcia, H., Rico, C. and Tejero, I. (2007). Characterisation of solid and liquid fractions of dairy manure with regard to their component distribution and methane production. *Bioresource Technol* **98**(5), 971–979.
- Rossini, M., Garrido, J.G. and Galluzzo, M. (1999). Optimisation of the coagulation–flocculation treatment: influence of rapid mix parameters. *Water Res* **33**, 1817–1826.
- Sala, L. and Serra, M. (2004). Towards sustainability in water recycling. *Water Sci Technol* **50**(2), 1–8.
- Salminen, E., Rintala, J., Harkonen, J., Kuitunen, M., Hogmander, H. and Oikari, A. (2001). Anaerobically digested poultry slaughterhouse wastes as fertiliser in agriculture. *Biores Tech* **78**, 81–88.
- Samkutty, P.J., Gough, R.H. and McGrew, P. (1996). Biological treatment of dairy plant wastewater. *J Environ Sci Health* **A31**, 2143–2153.

- Sarathchandra, U., Ghani, A., Waller, J. *et al.* (2006). Impact of carbon-rich dairy factory effluent on growth of perennial ryegrass (*Lolium perenne*) and soil microorganisms. *Eur J Soil Biol* **42**, 13–22.
- Sarkar, B., Chakrabarti, P.P., Vijaykumar, A. and Kale, V. (2006). Wastewater treatment in dairy industries-possibility of reuse. *Desalination* **195**, 141–152.
- Scerra, V., Caridi, A., Foti, F. and Sinatra, M.C. (1999). Influence of dairy *Penicillium* spp. on nutrient content of citrus fruit peel. *Anim Feed Sci Technol* **78**, 169–176.
- Schaafsma, J.A. and Baldwin, A.H. (1999). An evaluation of a constructed wetland to treat wastewater from a dairy farm in Maryland, USA. *Ecol Engin* **14**(1–2), 199–206.
- Schinner, F. and Von Mersi, W. (1990). Xylanase, CM cellulase and invertase activity in soil: an improved method. *Soil Biol Biochem* **22**, 511–515.
- Şengil, I.A. and Ozacar, M. (2006). Treatment of dairy wastewaters by electrocoagulation using mild steel electrodes. *J Hazard Mater* (in press).
- Shi, W., Norton, J.M., Miller, B.E. and Pace, M.G. (1999). Effects of aeration and moisture during windrow composting on the nitrogen fertiliser values of dairy waste composts. *Appl Soil Ecol* **11**(1), 17–28.
- Standard Methods for the Examination of Water and Wastewater (1995). Standard Methods for the Examination of Water and Wastewater, 19th edn. American Public Health Association/American Water Works Association/Water Environment Federation, Washington DC, USA.
- Szego, M. (1988). Effluent treatment in the Hungarian dairy industry up to the 80's. *Tejipar* **37**, 68–71.
- Tani, M., Sakamoto, N., Kishimoto, T. and Umetsu, K. (2006). Utilisation of anaerobically digested dairy slurry combined with other wastes following application to agricultural land. *Int Congress Series* **1293**, 331–334.
- Tanner, C.C., Clayton, J.C. and Upsdell, M.P. (1995a). Effect of loading rate and planting on treatment of dairy farm wastewaters in constructed wetlands I. Removal of oxygen demand, suspended solids and faecal coliforms. *Water Res* **29**(1), 17–26.
- Tanner, C.C., Clayton, J.C. and Upsdell, M.P. (1995b). Effect of loading rate and planting on treatment of dairy farm wastewaters in constructed wetlands II. Removal of nitrogen and phosphorus. *Water Res* **29**(1), 27–34.
- Tavares, J.F.P., Baptista, J.A.B. and Marcone, M.F. (1997). Milk-coagulating enzymes of tuna fish waste as a rennet substitute. *Int J Food Sci Nutrit* **48**, 169–176.
- Thassitou, P.K. and Arvanitoyannis, I.S. (2001). Bioremediation: a novel approach to food waste management. *Trends Food Sci Technol* **12**, 185–196.
- Tripathi, B.D. and Upadhyay, A.R. (2003). Dairy effluent polishing by aquatic macrophytes. *Water Air Soil Pollut* **143**, 377–385.
- Turan, M. (2004). Influence of filtration conditions on the performance of nanofiltration and reverse osmosis membranes in dairy wastewater treatment. *Desalination* **170**, 83–90.
- Uludag-Demirer, S., Demirer, G.N. and Chen, S. (2005). Ammonia removal from anaerobically digested dairy manure by struvite precipitation. *Process Biochem* **40**, 3667–3674.
- Umetsu, K., Kondo, R., Tani, M. and Hayashi, T. (2002). Fertiliser value of anaerobically co-digested dairy manure and food processing wastes. In *Greenhouse Gases and*

- Animal Agriculture* (J. Takahashi and Young, eds), pp. 331–342. Elsevier Science B.V., Amsterdam, the Netherlands.
- Uresti, R.M., Tellez-Luis, S.J., Ramirez, J.A. and Vazquez, M. (2001). Use of dairy proteins and microbial transglutaminase to obtain low-salt fish products from filleting waste from silver carp (*Hypophthalmichthys molitrix*). *Process Biochem* **36**, 809–812.
- Van Dijk, A. (2001). Life cycle assessment of conventional and organic pig production in the Netherlands. MSc Thesis, Animal Production Systems Group, Wageningen University, Wageningen, The Netherlands.
- Vasala, A., Panula, J. and Neubauer, P. (2005). Efficient lactic acid production from high salt containing dairy by-products by *Lactobacillus salivarius* ssp. *salicinius* with pre-treatment by proteolytic microorganisms. *J Biotechnol* **117**, 421–431.
- Venkataraman, J., Satyanarayan, S. and Kaul, S.N. (1988a). Effect of depth on reactor performance of an anaerobic packed-bed reactor for dairy waste. *Indian J Environ Protect* **8**, 743–748.
- Venkataraman, J., Satyanarayan, S. and Kaul, S.N. (1988b). Performance evaluation of two-stage anaerobic fixed-film fixed-bed reactor system treating dairy wastewater using special media. *Indian J Environ Protect* **8**, 919–925.
- Vidal, G., Carvalho, A., Mendez, R. and Lema, J.M. (2000). Influence of the content in fats and proteins on the anaerobic biodegradability of the dairy wastewaters. *Bioresource Technol* **74**, 231–239.
- Wang, P., Changa, C.M., Watson, M.E., Dick, W.A., Chen, Y. and Hoitink, H.A.J. (2004). Maturity indices for composted dairy and pig manures. *Soil Biol Biochem* **36**, 767–776.
- Wen, Z., Liao, W. and Chen, S. (2005). Production of cellulase/ β -glucosidase by the mixed fungi culture *Trichoderma reesei* and *Aspergillus phoenicis* on dairy manure. *Process Biochem* **40**, 3087–3094.
- Wendt, K. (1995). Determination of nitrate/nitrite in surface and wastewaters by flow injection analysis. QuickChem[®] Method 10-107-04-1-A. Revised by A. Sardina. 2000. Lachat Instruments, Loveland.
- Wheatley, A. (1990). *Anaerobic digestion: a waste treatment technology*. Elsevier Applied Science, London.
- Wilkie, A.C., Castro, H.F., Cubinski, K.R., Owens, J.M. and Yan, S.C. (2004). Fixed film anaerobic digestion of flushed dairy manure after primary treatment: wastewater production and characterisation. *Biosyst Engin* **89**(4), 457–471.
- Young, L. and Pian, C.C.P. (2003). High-temperature, air-blown gasification of dairy-farm wastes for energy production. *Energy* **28**, 655–672.

Electronic sources

- <http://www.foodsci.uoguelph.ca/dairyedu/intro.html> (accessed 2006, September, 30)
- <http://www.makinganergy.com/Dairy%20Waste%20Handbook.pdf> (accessed 2006, September, 30)
- http://www.sera17.ext.vt.edu/Documents/BMP_Constructed_Treatment_Wetlands.pdf (accessed 2006, October, 15)

- <http://www.esemag.com/index.html> (accessed 2006, October, 25)
- <http://cru.cahe.wsu.edu/CEPublications/eb1947b/eb1947b.pdf> (accessed 2006, October, 15)
- http://www.agrifood-forum.net/publications/guide/d_chp2.pdf (accessed 2006, October, 17)
- http://www.agrifood-forum.net/publications/guide/d_chp0.pdf (accessed 2006, October, 17)
- <http://www.fao.org/WAIRDOCS/LEAD/X6114E/x6114e06.htm#4.%20DAIRY%20INDUSTRY> (accessed 2006 October, 19)
- <http://www.fao.org/WAIRDOCS/LEAD/X6114E/x6114e07.htm#b3-5.3.%20Treatment%20of%20wastewater> (accessed 2006, October, 21)
- [http://epanote2.epa.vic.gov.au/.../2f1c2625731746aa4a256ce90001cbb5/455a88b76f16a8254a2565fc0008e51b/\\$FILE/570.pdf](http://epanote2.epa.vic.gov.au/.../2f1c2625731746aa4a256ce90001cbb5/455a88b76f16a8254a2565fc0008e51b/$FILE/570.pdf) (accessed 2006, October, 22)
- <http://www.fao.org.wairdocs/LEAD/X6114E/x6114e06.htm> (accessed 2006, October, 22)
- <http://www.edibon.com/products/catalogues/en/systems/pilotplants/LE00.pdf> (accessed 2006, October, 22)

Fish Waste Management: Treatment Methods and Potential Uses of Treated Waste

Ioannis S. Arvanitoyannis and Aikaterini Kassaveti

Introduction	861
Treatment methods	864
Uses of fish waste	882
Inputs and outputs in fisheries	924

Introduction

Marine aquaculture involves a variety of species, rearing techniques and husbandry methods. Extensive marine aquaculture involves the farming of finfish or shellfish in a 'natural' habitat with no supplementary food added and with minimum impact on the environment (Midlen and Redding, 1998; Oceanographic Applications to Eutrophication in Regions of Restricted Exchange (OAERRE), 2001). Marine capture fisheries contribute over 50% of total world fish production and more than 70% of this production has been utilized for processing. Recent estimates revealed that current discards from the world's fisheries exceed 20 million tons, equivalent to 25% of the total production of marine capture fisheries (FAOSTAT, 2001). Global production of fish and shrimp has been steadily increasing over the last decade and this trend is expected to continue. Of the estimated 131 million tons of fish produced in 2000 in the world, nearly 74% (97 million tons) was used for direct human consumption. The remainder (about 26%) was utilized for various non-food products, mostly for reduction to meal and oil. As a highly perishable commodity, fish has a significant requirement for processing.

In 2000, more than 60% of the total world fisheries production underwent some form of processing (FAO, 2002).

Fishmeal and fish oil products have a high nutritional value. Fishmeal is used as feed for livestock and farmed fish and the oil is used as an ingredient in paints and margarine. Fishmeal is derived from the dry components of the fish and the oil from the oily component. Water, which makes up the rest of the fish matter, is evaporated during the process (http://www.agrifood-forum.net/publications/guide/f_chp2.pdf). Fish processing generates large amounts of solid and liquid wastes as shown in Figure 14.1. Normally, more than half of the raw-material weight is unused, e.g. only about 15% of the round shrimp becomes a canned shrimp product (El-Beltagy *et al.*, 2005).

The worldwide expansion of marine fish farming caused growing concern regarding its environmental impact (Lupatsch *et al.*, 2003). Industrial processes always accompany wastes that are a significant risk to the environment. Technologies that would treat these wastes, or even better recover some useful organic materials before disposal, are necessary to mitigate pollution (Quitain *et al.*, 2001). The worldwide growth in aquaculture production in the last 30 years has greatly increased the awareness of its environmental impacts (Iwama, 1991; Silvert, 1992; Ervik *et al.*, 1997; Hansen *et al.*, 2001).

Fish farm waste affects not only the area surrounding and directly affected by the effluent, but can also alter a wider coastal zone at different ecosystem levels, thus reducing the biomass, density and diversity of the benthos, plankton and nekton and modifying natural food webs (Gowen, 1991; Pillay, 1991). The most visible effects of fish cage aquaculture are: output of particulate organic waste that will increase biochemical oxygen demand (BOD₅), release of dissolved phosphorus and dissolved nitrogen (Ruokolahti, 1988; Ronnberg *et al.*, 1992). There is a consensus that at least 80% of the total nutrient losses from fish farming is plant, available as potentially eutrophivating substances (Hakansson *et al.*, 1988; Persson, 1988, 1991), being indicated with increased macroalgae growth in areas with fish farming (Ruokolahti, 1988; Ronnberg *et al.*, 1992).

The central concept of life cycle assessment (LCA) is to combine, in a small number of indicators, the polluting emissions and resources utilized during the course of the life of a product (Payraudeau and van der Werf, 2005) (Table 14.1). This method has been the subject of considerable efforts towards standardization of the calculation of impacts (ISO/DIS, 2000a) and the interpretation of results (ISO/DIS, 2000b).

As the aquaculture industry develops, efficient, cost-effective and environmentally friendly preventive and bioremediation methods of improving effluent water quality prior to discharge into receiving waters of sensitive areas will be necessary (Jones *et al.*, 2001). An important waste reduction strategy for the industry is the recovery of marketable by-products from fish wastes (<http://www.earthprint.com/unep/download/2481.pdf>). The three most common methods for utilization of aquatic waste (either from aquaculture or wild stock) are the manufacture of fishmeal/oil, the production of silage or the use of waste in the manufacture of organic fertilizer (http://www.fao.org/documents/show_cdr.asp?url_file=/DOCREP/003/X9199E/X9199E00.HTM).

The EU has introduced many Directives over the last 30 years that have led to the implementation of national legislation relevant to the management of the environmental impact of marine aquaculture through the establishment of appropriate Environmental

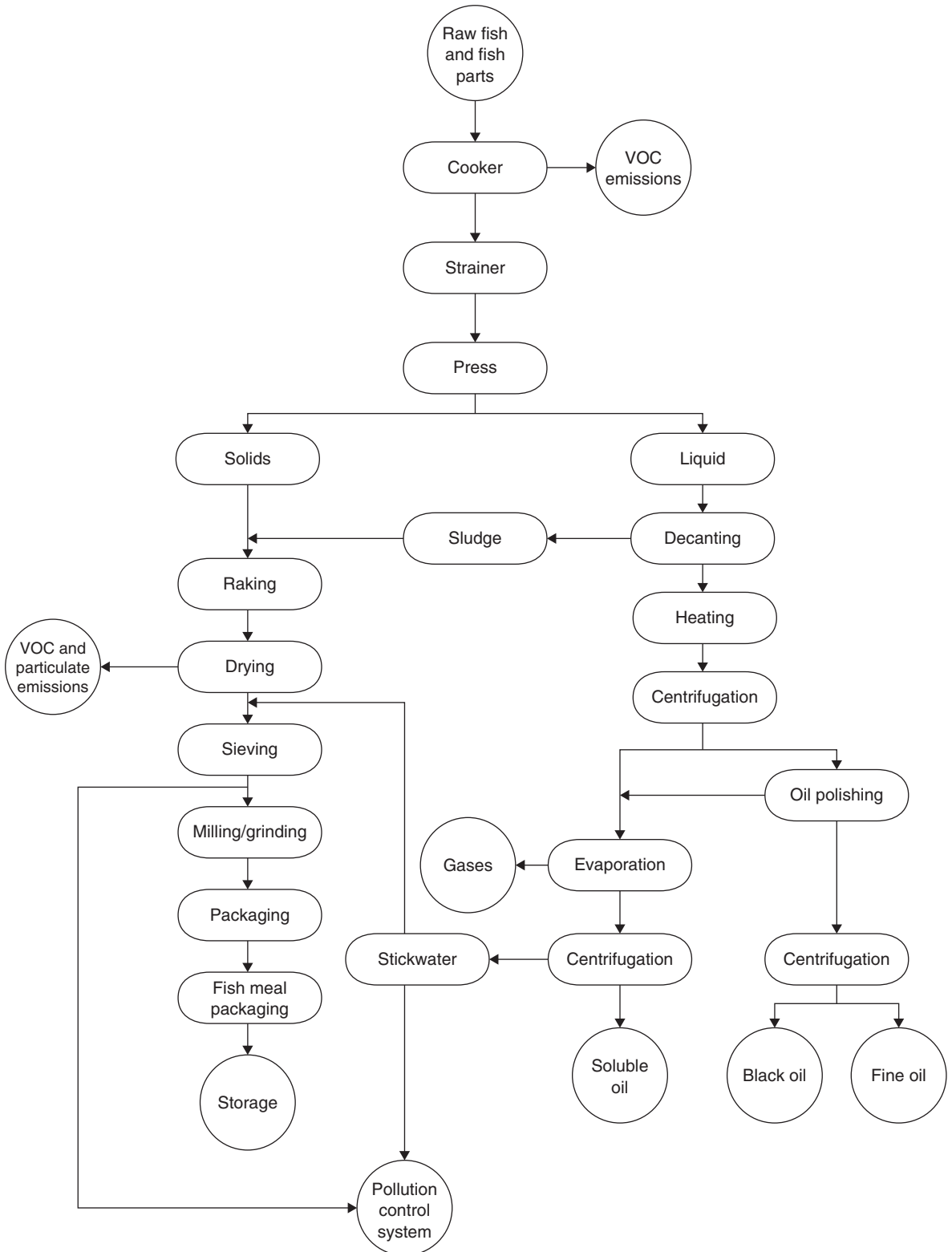

Figure 14.1 Flow diagram of fishmeal and fish oil production (adapted from <http://www.epa.gov/ttn/chief/ap42/ch09/final/c9s13-1.pdf>; http://www.agrifood-forum.net/publications/guide/f_chp2.pdf)

Table 14.1 Electricity (MJ) and thermal energy (kWh) requirements of canning tuna industry

Process	Thermal energy (MJ)	Electricity (kWh)
Fish reception	–	0.67
Fish thawing	111	
Cutting	–	23.62
Cooking	1385	24.19
Manual cleaning	–	9.69
Liquid dosage and can filling	–	47.19
Sterilization	2083	45.61
Quality control and packaging	–	33.5
Ancillary activities (wastewater treatment, tins production for packaging)	–	64.29

Adapted from Hospido *et al.*, 2006)

Quality Objectives (EQOs) and Environmental Quality Standards (EQSs). In the context of marine aquaculture, environmental protection measures have been established at three levels:

- 1 general policy
- 2 specific measures
- 3 regulations that control specific local conditions (Eleftheriou and Eleftheriou, 2001).

The most relevant EC Directives in relation to the management of the environmental impacts of marine aquaculture are: Hazardous Substances Directive (76/464/EEC), Quality of Shellfish Growing Waters Directive (79/923/EEC), Shellfish Directive (91/492/EEC), Environmental Impact Assessment Directive (85/337/EEC and 97/11/EEC), Strategic Environmental Assessment Directive (2001/42/EC), Species and Habitats Directive (92/43/EEC), Wild Birds Directive (79/409/EEC) and Water Framework Directive (2000/60/EC) (Read and Fernandes, 2003).

The main target of this chapter is to summarize the current and potential treatment methods of fish waste and uses of treated waste by means of informative flow diagrams, tables and the inputs and outputs (energy consumption, wastewater, solid waste) of various fish processes.

Treatment methods

With increased interest in environmentally friendly farming practices and the potential for regulatory action by EPA, EU and other agencies, the aquaculture industry has been focusing on ways to reduce the wastes (environmental impact) from aquaculture facilities (<http://www.wvu.edu/~agexten/aquaculture/waste02.pdf#search=%22Best%20management%20practices%20to%20reduce%20aquaculture%20waste%22>). The processes being used nowadays for fish waste treatment are hydrolysis, bioremediation,

anaerobic treatment, filtration, screening and several other miscellaneous/multifunctional methods.

Hydrolysis

Most of the initial work on fish protein hydrolysis was performed in the 1960s. Emphasis was on fish protein concentrate as an inexpensive nutritious protein source for developing countries (Kristinsson and Rasco, 2000a). Enzymatic hydrolysis of fish protein has been employed as an alternative approach for converting underutilized fish biomass into edible protein products, instead of animal feed or fertilizer (Suzuki, 1981; Diniz and Martin, 1996).

Fish meat (a horse mackerel) was liquefied with hydrolysis in a reactor under subcritical (10^{-3} kg fish meat, 3.36×10^{-6} cm³ Milli-Q water) and supercritical (10^{-3} kg fish meat, 3.06×10^{-6} (280°C, 30 MPa) or 1.76×10^{-6} (400°C, 30 MPa) cm³ Milli-Q water) conditions at 200–400°C (Yoshida *et al.*, 1999, 2000). At 200°C, 3.35 MPa and 5 min reaction time, lactic acid (0.03 kg/kg of dry meat), phosphoric acid (0.12 kg/kg of dry meat) and histidine (0.01 kg/kg of dry meat) were formed. At 280°C, 6.42 MPa and 30 min reaction time, pyroglutamic acid (0.095 kg/kg of dry meat) was produced. On the other hand, amino acids (cystine, alanine, glycine and leucine) were obtained at 270°C and 5.51 MPa. Oil was extracted from a water-insoluble phase with hexane and was rich in fatty acids, such as eicosapentanoic acid (EPA) and docosahexanoic acid (DHA) (Yoshida *et al.*, 1999). According to Yoshida *et al.* (2000) at 200–400°C and 5 min reaction time, oil, amino acids (cystine, alanine and glycine) and organic acids (pyroglutamic acid) were formed under subcritical conditions.

Homogenized minced Atlantic salmon (*Salmo salar*) muscle was treated with one of four alkaline proteases (Alcalase 2.4L, Flavourzyme 1000L, Corolase PN-L and Corolase 7089) or endogenous digestive proteases were added in order to obtain 5, 10 and 15% degrees of hydrolysis (DH). The enzymatic hydrolysis was conducted at pH 7.5, 40°C and 7.5% protein content. Lipid content of fish protein hydrolysates (FPH) was low, while protein and nitrogen recovery was 71.7–88.4% and 40.6–79.9%, respectively. The highest protein and nitrogen recovery were reported when the sample was treated with Alcalase and Corolase 7089 proteases. Furthermore, proteases with high nitrogen recovery were produced at 15% DH, whereas the protein content of the hydrolysates did not differentiate with regard to DH. On the other hand, hydrolysates solubility increased at high pH (pH 7) and varied between 92.4 and 99.7%. Fish protein emulsification capacity and stability were higher at 5% DH and with Corolase PN-L and Corolase 7089 treatment. Fish protein emulsification capacity was 75–299 ml of oil emulsified per 200 mg of protein and fish protein emulsification stability varied from 50 to 70%. Finally, fat absorption was higher at 5 and 10% DH and ranged from 2.86 to 5.98 ml of oil/g of protein (Kristinsson and Rasco, 2000b).

Northern shrimp (*Pandalus borealis*) waste (heads and scales) was mixed with water (1:1) and 5% (v, w) protease (Alcalase) was added to the mixture. The sample was hydrolyzed at 40°C for 2 h in an open stirred reactor, whereas solid tissues and crude hydrolysate were separated with pressing. The obtained press cake was processed to

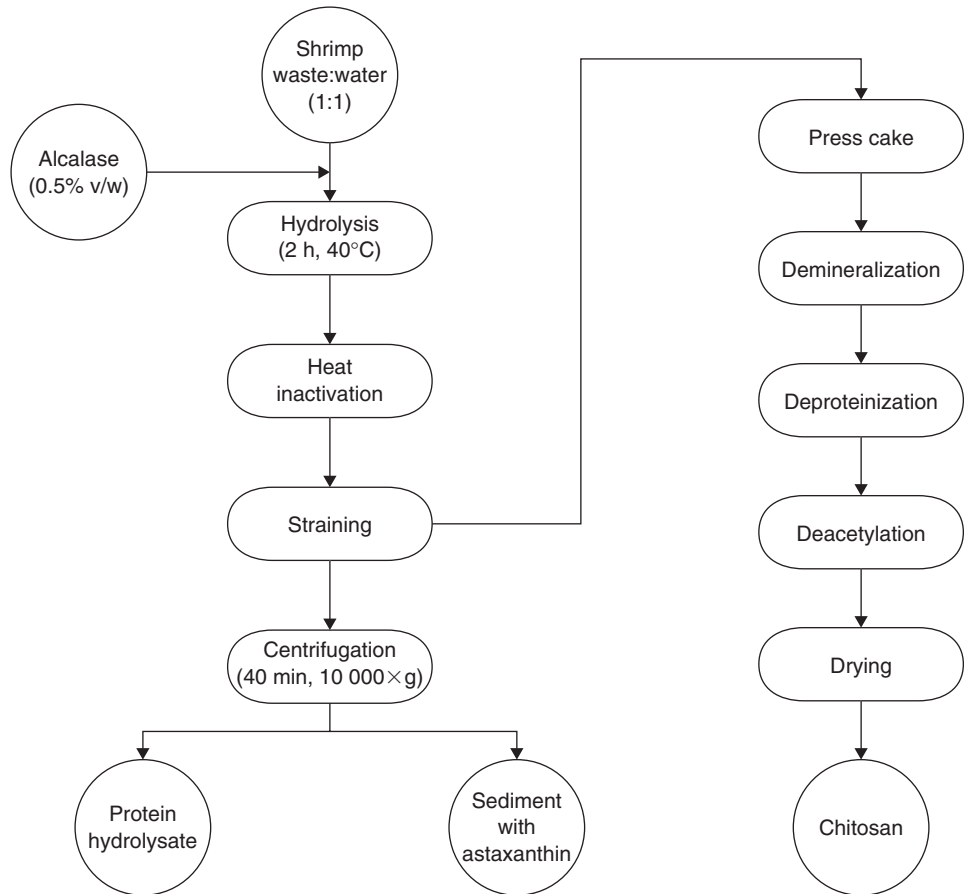

Figure 14.2 Flow diagram of a new process for shrimp wastes utilization (adapted from Gildberg and Stenberg, 2001)

chitosan by demineralization, deproteinization, deacetylation and drying. Suspended solids from the crude hydrolysate were centrifuged and protein hydrolysate and astaxanthin were recovered (Figure 14.2). This method was also compared to the traditional method for enzymic removal of proteins from demineralized shrimp waste that was carried out by Gagne and Simpson (1993). According to the conventional method, 12.8% Kjeldahl nitrogen and 8.8% total dry matter were recovered, whereas following this method 68.5% nitrogen and 33.2% total dry matter were retrieved. The obtained chitosan from this process had higher viscosity and similar dry matter ash and Kjeldahl nitrogen content to the one obtained from the conventional process. The protein hydrolysate was rich in essential amino acids, thus indicating its potential use as a feed in salmonid fish or microorganisms (Gildberg and Stenberg, 2001).

Gao *et al.* (2006) applied two different acid hydrolysis methods in order to produce lactic acid from fish heads and bony parts. According to process A, minced raw material mixed with water (1:1 ratio) (initial pH 1) was hydrolyzed at 121°C for 20 min and centrifuged at 2706 g for 20 min, while the supernatant was kept and utilized as a

nutrient source for lactic acid production. In process B, minced fish wastes were pre-treated at 121°C for 20 min without the addition of acid. The mixture was centrifuged and the obtained residue and the supernatant were treated according to process A (Figure 14.3). Lactic acid production was inhibited when unhydrolyzed fish waste was used as a substrate for fermentation, whereas glucose was converted to lactic acid when hydrolyzed fish waste was used as a nutrient source. Lactic acid production increased with hydrolysis time, especially when hydrolysis lasted up to 40 min. The fish waste hydrolysate produced by process B was rich in nutrients and can be used effectively as a substitute for yeast extract.

The potential of amino acids and glucosamine production from shrimp shell hydrothermal treatment at high-temperatures and high-pressure (45 MPa) water was examined by Quitain *et al.* (2001). Shrimp shells and deionized water (weight ratio = 1:125, dry basis) were placed in a batch reactor apparatus under sub- and supercritical conditions at various temperatures (90–400°C) and reaction times (5–60 min). The maximum amount of amino acids (70 mg/g dry shrimp) was reported at 250°C in 60 min, which was about 2.5 times higher than the total amino acids obtained at 90°C. Glycine (Gly) and alanine (Ala) production increased with temperature, whereas it decreased at temperatures above 250°C.

Bioremediation

Bioremediation is a general concept that includes all those processes and actions that take place in order to biotransform an environment, already altered by contaminants, to its original status (Thassitou and Arvanitoyannis, 2001). As the aquaculture industry develops, effective, cost-effective and environmentally friendly preventive and bioremediation methods of improving effluent water quality prior to discharge into receiving waters of sensitive areas will be necessary (Jones *et al.*, 2001).

Sterilized wheat bran (700 g), *Aspergillus awamori* spores (0.7 g) and minced and sterilized sardine fish (2638 g) were mixed and placed in a ventilated incubator for 5 days at 40°C. The fermented product was mixed with corn-soybean mixture at the levels of 0.1, 1.0, 5.0 and 10.0% in order to examine the digestibilities of crude protein (CP) and dry matter (DM). After fermentation, crude protein, crude fat and nitrogen-free extracts decreased up to 2.6, 22.2 and 25.7%, respectively. On the other hand, an increase up to 16.1% in crude fiber content was recorded; thus indicating that crude fiber may be synthesized by *Aspergillus awamori*. Furthermore, during the fermentation, a number of enzymes, such as glucoamylase (9.71 U), α -glucosidase (0.21 U), α -amylase (21.69 U) and acidic protease (17 778 U), were produced. Fermented fish-meal had no effect on CP digestibility, whereas an increase in DM digestibility was reported regardless of the levels of fishmeal and it was significant at 5 and 10% (Yamamoto *et al.*, 2005).

Ayangbile *et al.* (1997) performed three different experiments in order to examine the effect of chemicals on crab waste and on fermentation characteristics of mixtures of ensiled crab waste and straw. According to treatment A, a mixture of 1.5% propionic/formic acid (1:1) and crab-processing waste were ensiled with wheat straw, sugarcane

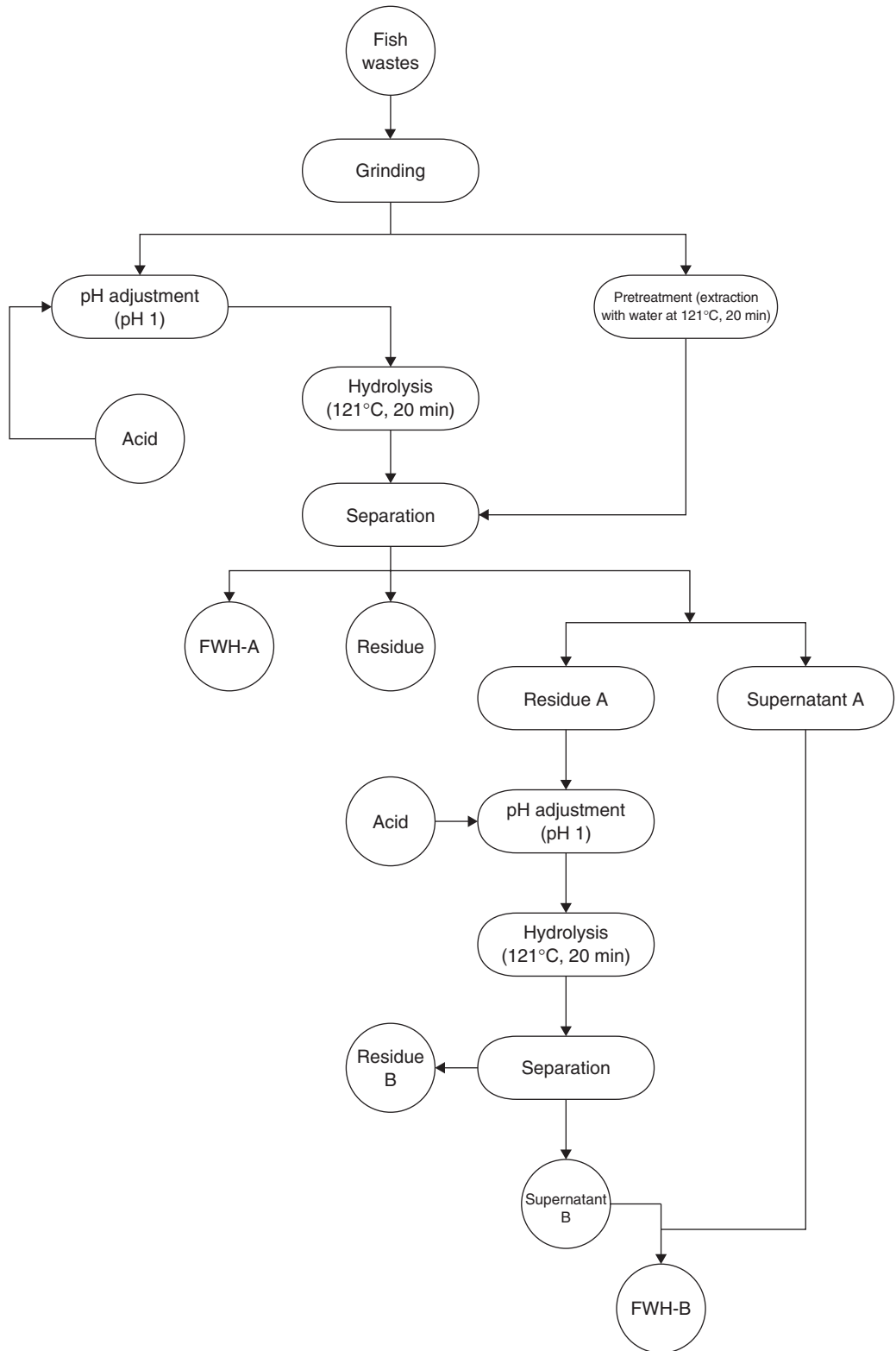

Figure 14.3 Flow diagram of the production of fish waste hydrolysate (FWH) (adapted from Gao *et al.*, 2006)

molasses and water (32:32:16:20, w/w) with or without 0.1% microbial inoculant (*Streptococcus faecium* and *Lactobacillus plantarum*). In treatment B, 0.2% sodium hypochlorite (NaOCl) or 0.4% hydrogen peroxide (H₂O₂) were added to crab waste and the mixture was ensiled just like treatment A. Treatment C involved the addition of 1% sodium nitrite (NaNO₂) or 0.2% and 0.4% NaOCl/calcium hypochlorite (Ca(OCl)₂) or 1% NaNO₂ to crab waste and the blend was ensiled as described in treatment A. In treatment A, waste degradation was prevented for 14 days, while a significant decrease in pH and water-soluble carbohydrates (WSC) and an increase in lactic acid concentration were reported. Furthermore, in treatment B, waste deterioration was prevented for 7 days, whereas trimethylamine (TMA) concentration increased (from 3.70 to 12.85 mg of N/100 g) when crab waste was treated with NaOCl and remained stable (from 2.66 to 2.71 mg of N/100 g) when treated with H₂O₂.

Shih and coworkers (2003) conducted 5-month fermentation experiments utilizing different combinations of bonito's body parts (flesh body, head, fins and viscera) with or without addition of enzymes, such as soybean koji (*Aspergillus oryzae*), ang-khak (*Monascus purpureus*) or viscera in order to produce fish sauce. (Treatment 1: blended and sterilized bonito wastes were mixed with viscera (1:2, w/w) and a 20% salt solution; Treatment 2: blended and sterilized whole bonitos were mixed with viscera (1:2, w/w) and a 20% salt solution; Treatment 3: blended bonito wastes were mixed with a 20% salt solution; Treatment 4: blended whole bonitos were mixed with a 20% salt solution; Treatment 5: blended and sterilized bonito wastes were mixed with 38% soybean koji, stored for 2 days at room temperature, while a 20% salt solution was added; Treatment 6: blended and sterilized whole bonitos were mixed with 38% soybean koji, stored for 2 days at room temperature, while a 20% salt solution was added; Treatment 7: blended and sterilized bonito wastes were mixed with 38% ang-khak, stored for 2 days at room temperature, while a 20% salt solution was added; Treatment 8: blended and sterilized whole bonitos were mixed with 38% ang-khak, stored for 2 days at room temperature, while a 20% salt solution was added.) The results revealed that bonitos (whole fish and waste) treated with soybean koji and ang-khak had higher total sugar content and amylase activities values ranging from 10.8 to 17.4 mg/l and 5.0–100 U/ml, respectively. On the other hand, total sugar content of treated bonitos without the addition of enzymes was 3.6–5.9 mg/l, whereas no amylase activity was detected. Furthermore, protein and amino acids values of treated whole bonitos were slightly higher than treated fish waste. Volatile basic nitrogen (VBN) and trimethylamine (TMA), two indices for fishiness odor, were found to exceed the thresholds of 6 mg/100 g and 50 mg/100 g. Fish sauces with better qualities were obtained from whole fish treatment with ang-khak.

Martin (1999) examined the potential of recovering valuable biomass present in fish waste by composting fisheries processing waste with peat. A mixture of fish waste and peat (bulking agent) were composted in a passively aerated composting system. Compost extracts were sterilized and inoculated at a ratio of 5% (v/v) before use as a substrate for the acid-resistant fungus *Scytalidium acidophilum* ATCC 26774 (150 rpm, 25.0°C, pH 2.0 ± 0.1, 8–10 days) (Figure 14.4). Acid extracts of compost had higher concentrations of nutrients (lipids, carbohydrates, and protein) than the compost. Compost extracts can be effectively utilized as a substrate for the growth of

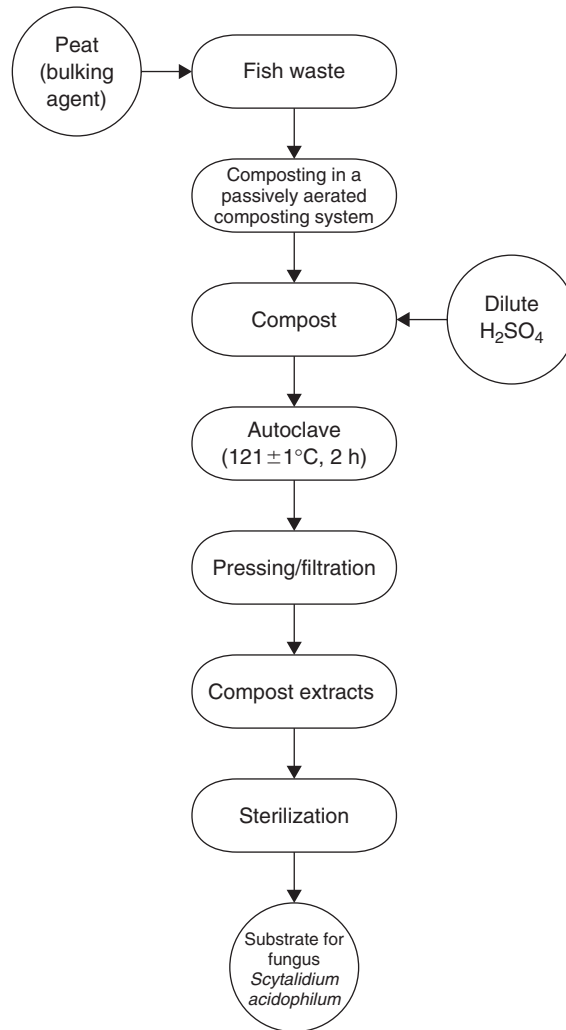

Figure 14.4 A fundamental process for conversion of fisheries processing waste to valuable compost (adapted from Martin, 1999)

the fungus *S. acidophilum*, for the biofiltration of liquid and gas effluents and in the growth of mushrooms.

Small and large silo experiments of seafood processing waste were conducted by Samuels *et al.* (1992). In small silo experiments, seafood waste was ensiled with corn stover or peanut hulls (dry matter (DM) levels 40–60%), alone and with 5% dry molasses or 1% formic acid. The two seafood wastes were ensiled with wilted Johnsongrass (*Sorghum halepense* L.) (50:50, w/w), with and without the addition of 5% dry molasses (experiment A). Another small silo experiment was performed using crab waste and corn stover (40:60 and 60:40 (w/w)) with the addition of 5% dry molasses (experiment B). In large silo experiments, fish and crab processing wastes were ensiled with wheat straw (preparations of fish waste and straw 70:30 and 51:49,

crab waste and straw 60:40 and 40:60 (w/w), wet basis), while 5% dry molasses and 16% acetic acid (v/w) were also added. In small silo experiments, all silages with fish waste had acceptable aroma, apart from silages with crab waste with 40% and 50% DM. The pH of fish waste silages and crab waste silages was 6.5 and 8.0, respectively. Furthermore, during the ensiling process, concentration of coliforms and fecal coliforms was at low levels. In large silo experiments, a decrease in pH (pH <5) of fish waste and straw silages occurred and, particularly, the lower the proportions of fish waste the higher the pH decrease.

A mixture of fish processing waste (offal) and a bulking agent (a blend of sawdust and wood shavings, 1:1 by volume) (3:1 wet weight ratio) was composted for 150 days in static aerated piles (in-vessel method) under different weather conditions (winter and summer). Temperatures were kept above 45°C for 60 days, at 55°C for 9 days and then peaked several times, and at 25°C for 120–150 days. A significant decrease in electric conductivity (EC), ammonium as nitrogen (NH_4^+ -N) and water-soluble carbon (WSC) was reported, whereas after 80 days, volatile fatty acids (VFA) decreased to non-detectable levels, with the exception of acetic values. The ratio WSC:TN, an index of compost maturity, revealed that compost obtained during summer was mature (WSC:TN = 0.7) within 150 days, while compost obtained in winter required additional days to achieve maturity (WSC:TN = 1.2) (Laos *et al.*, 2002).

Three ensiling experiments of crab waste and wheat straw treated with different additives were conducted by Abazinge *et al.* (1993). In small silo experiments, crab waste and wheat straw (1:1, wet basis) were ensiled with 0–20% dry molasses, 0–0.1% microbial silage inoculant and 0–5.4% phosphoric acid (H_3PO_4) and 20% water (Experiment 1). In another small silo experiment, 10–20% dry molasses, 0 or 0.1% microbial silage inoculant and 0 or 20% water were added (Experiment 2). In large silo experiments, crab waste and wheat straw (1:1 proportions) were ensiled with:

- 1 20% dry molasses
- 2 20% dry molasses and 0.1% microbial silage inoculant
- 3 16% acetic acid.

In small silo experiments (Experiment 1), pH was higher (pH 7.34–7.36) at mixtures without added molasses or acid, whereas the trimethylamine content (TMA) was lower varying from 8.11 to 18.84% dry matter for molasses and inoculant treated silages. Lactic acids levels increased and pH decreased linearly with increasing levels of molasses (Experiment 2). In mixtures with added water and molasses (Experiment 2), concentrations of volatile fatty acids (VFA), acetic, propionic and isobutyric acid were higher, while addition of 10–20% dry molasses to crab-straw mixtures before ensiling resulted in substantial amounts of lactic acid. In large silo experiments, silages treated with 20% molasses and 0.1% inoculant, had lower pH (4.70) and higher lactic acid concentration (12.76% dry matter).

A mixture of fish waste, heads and viscera of different fish, but mainly sardines (*Sardinia ilchardus*) and molasses was inoculated with strains of yeasts (32 strains of yeasts *Saccharomyces cerevisiae* and *Candida* spp. and 14 strains of lactic acid bacteria *Lactobacillus plantarum* and *Pediococcus acidi-lactici*) at 28°C for 10 days and

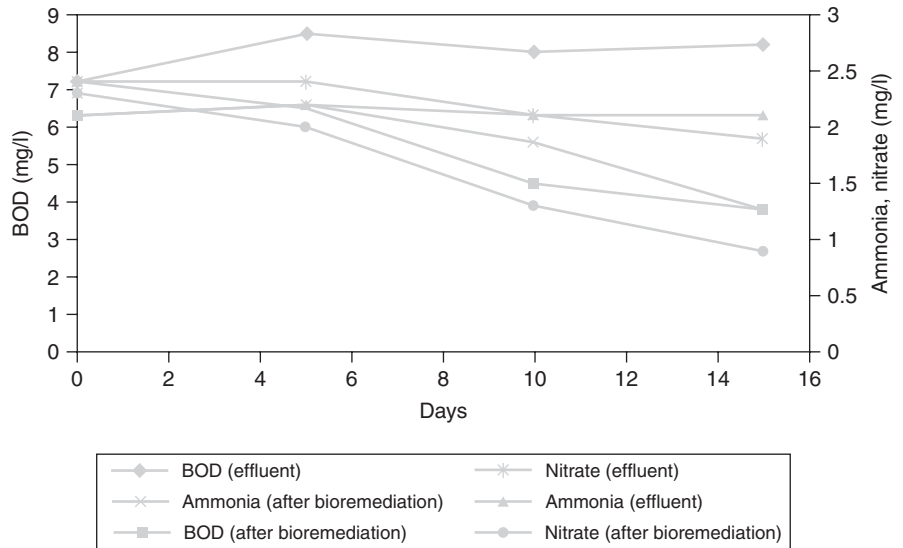

Figure 14.5 Trends in BOD₅, ammonia and nitrate concentration in effluent and after bioremediation with mats (adapted from Paniagua-Michel and Garcia, 2003)

fermented at different values of pH (4.0–5.8), temperature (20–30°C) and molasses proportions (20–30%, w/w). The optimal conditions for the fermentation process were at pH 5.0–5.4, 26°C in a short incubation time and below 30°C in the fermentation by yeasts and 30% of molasses. Ten days after the incubation period at 26°C, the fermented product was free of coliforms and *Salmonella*. Furthermore, a net decrease in pH (16.3–17.3%), dry matter (1.9–18.6%), reducing sugars (RS) (12.4–46.4%), protein (0–16.3%), total nitrogen (TN) (4.0–18.8%) and trimethylamine (TMA) (55.0–82.6%) in the final product was observed, whereas ash, fat, non-protein-nitrogen (NPN) and total volatile nitrogen (TVN) displayed a pronounced increase (Faid *et al.*, 1994).

Paniagua-Michel and Garcia (2003) utilized indigenous microbial consortia for the construction of microbial mats for the bioremediation of a semi-extensive shrimp (*Litopenaeus vannamei*) pond effluent. The shrimp hatchery effluent was fed into three glass reactors at 24–27°C, pH 7.8–8.0, oxygen concentration 8 mg/l and hydraulic resistance time 5 days. Each reactor consisted of a retention chamber at the top for the water treatment, three stages with the constructed mats overlaid at each stage and several small holes serving as a sprinkling filter at the bottom. According to the design of the bioreactor, the effluent flows throughout the surface of the first bed, which contains mats, and then sprinkles to the second and third bed. After 20 days of treatment, 97% ammonia nitrogen and 95% nitrate nitrogen concentration removal was reported. Furthermore, at the end of the experimental period, 80% BOD₅ reduction occurred (Figure 14.5).

Anaerobic treatment

The anaerobic treatment of wastewater proceeds with degradation of the organic load to gaseous products (mainly methane and carbon dioxide) which constitute most of

the reaction products and biomass (<http://www.fao.org/DOCREP/003/V9922E/V9922E05.htm>). Treatment with anaerobic digestion may be a promising option, incorporating waste utilization and energy production in the form of biogas. The advances in anaerobic digestion over the last 40 years made the process an extremely attractive option for the treatment of highly polluted wastewaters (<http://vefur.rf.is/TAFT2003/PDF/Reddington.pdf#search=%22Anaerobic%20digestion%20of%20fish%20waste-A%20novel%20solution%20to%20the%20problem%3F%22>).

Anaerobic batch digestion of sisal pulp and fish wastes separately, as well as co-digestion of both substrates was investigated by Mshandete *et al.* (2004). Sisal pulp and fish waste (offal, scales, gills) and washing water, were digested separately at 5–60% wet biomass (v/v) in 30 batch bioreactors for 25 and 29 days, respectively. In the co-digestion experiment, mixtures of fish waste and sisal pulp of different proportions were digested in 15 bioreactors for 24 days at $27 \pm 1^\circ\text{C}$. The highest methane yield of $0.32 \text{ m}^3 \text{ CH}_4/\text{kg}$ volatile solids (VS) for sisal pulp and $0.39 \text{ m}^3 \text{ CH}_4/\text{kg}$ VS for fish waste at 5% TS was reported after 25 and 29 days, respectively. Co-digestion with 33% fish waste and 67% sisal pulp, at 16.6% TS and C:N ratio 16, resulted in the highest methane yield of $0.62 \text{ m}^3 \text{ CH}_4/\text{kg}$ VS, an increase of 59–94% in the methane yield compared to that obtained during the digestion of sisal pulp and fish wastes at 5% TS. Biogas recovery with 60–65% methane content was recorded in the case of anaerobic co-digestion of fish waste and sisal pulp.

Fishmeal process wastewater with high total ammonia content was treated for a year in an upflow anaerobic sludge blanket (UASB) reactor. The sample was fed in the reactor at 34°C and pH 7.3–7.9 and the organic loading rate (LR) was 10 and 16 g COD/l/day. Furthermore, batch experiments were also conducted in order to determine the specific methanogenic activity (SMA) at pH 7.1–8.5. At pH 7.9, volatile fatty acids (VFA) and trimethylamine (TMA) degradation up to 99% was reported and, at pH above 8.0, COD removal up to 15–17% occurred. At pH above 7.9, a slight decrease in acetate conversion was recorded, whereas at pH above 8.3, granule disintegration occurred. On the other hand, at higher pH values, the density (from 1067 to 1017 g/l), size (less than 0.4 mm), total solids (from 114.5 to 55.1 g TS/l) and volatile solids content (from 39.2 to 11.2 g VS/l) decreased. After 4 months of acclimatization, SMA of the granular biomass was the same at pH 7.1 and 8.5 (1.3–1.8 g COD g/VS/day). At pH 8.3 and 8.5, the SMA improved by 25% and 50%, respectively and at all pH values acclimatized pH showed 60% lower SMA (Sandberg and Ahring, 1992).

Vidotti *et al.* (2003) studied the amino acid composition of fish silages produced with acid digestion (20 ml/kg formic acid and 20 ml/kg sulfuric acid) and anaerobic fermentation (50 g/kg *Lactobacillus plantarum*, 150 g/kg sugar cane molasses) from different raw materials, such as saltwater (SW), freshwater fish (FW) and tilapia filleting residue (TR). The raw materials were separately mixed with 15% sugar cane molasses, 5% *Lactobacillus plantarum* culture media and 0.25% sorbic acid (w/w), in order to obtain fermented silage. When 2% formic acid (w/v) and 2% sulfuric acid (w/v) were added to the above mixture, acid silage was produced (Figure 14.6). The results indicated that acid silages had a higher protein content 69.91% (SW), 44.38% (FW) and 39.59% (TR), compared to fermented silages, 59.61% (SW), 42.09% (FW) and 35.84% (TR), respectively. Histidine, threonine and serine levels increased,

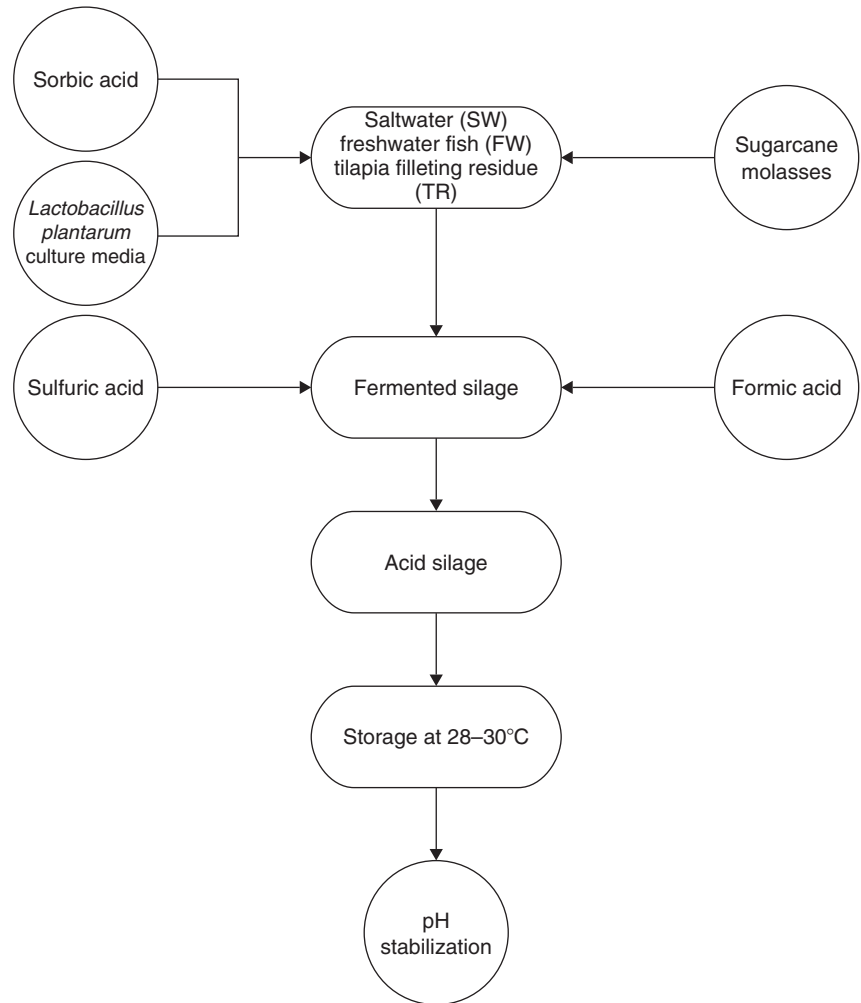

Figure 14.6 Flow diagram of silages production from three different raw materials (adapted from Vidotti *et al.*, 2003)

whereas levels of valine, isoleucine and leucine decreased in all products. All products can be used in balanced fish diets, due to their nutritional value.

Filtration/screening

Screening and filtration are discussed under a single heading because they share a common characteristic: separation of particles (cells) depends upon the difference between the size of the particles and that of the openings (screen) or pores (filter medium). The problem is that the screen or filter medium becomes clogged before a workable 'cake' can be accumulated (http://www.unep.or.jp/Ietc/Publications/spc/Solid_Waste_Management/Vol_I/15-Chapter9.pdf#search=%22food%20waste%20hydrolysis%20advantages%22).

Cattaneo-Vietti and coworkers (2003) utilized a small underwater device for wastewater processing. The system, called MUDS (marine underwater depuration system), was placed at sea over an urban sewage outflow of a submarine pipeline. Total suspended matter (TSM), BOD₅ and coliform-bacteria concentrations were reduced up to 90%, while the porous structure of the filter resulted in the development of protozoan and microbenthic communities, thus indicating the consumption of a significant amount of organic matter. Furthermore, predators (such as detritus feeder invertebrates and benthic and pelagic fishes) were attracted to the filter of the system causing organic matter recycling. The system favored the development of fish, the aggregation of fish species and the selection of marine organisms (bacteria, fungi, protozoa) capable of supporting the changes in water salinity and temperature.

The potential use of an ultra-low pressure membrane for the aquaculture wastewater treatment was investigated by Ali *et al.* (2005). Fish wastewater samples after sand treatment filtration were passed through polyethersulfone (PES) membranes, which were prepared by using a dry/wet phase inversion technique. The results indicated that total ammonium and total phosphorus were removed up to 85.70 and 96.49%, respectively at pressure 0.4–0.8 MPa.

Degradation rate experiments of solid waste from Atlantic salmon fish farms were conducted for 21 days by Buryniuk and coworkers (2005). Fish feed waste removal rate experiments were also performed. Frozen samples (–10°C) of solid waste were placed in tanks filled with saline (25–30% salinity) and distilled water, which were kept in the dark at 8°C and at oxygen concentration above 80%. After 21 days, C/N and nitrogen-free extracts (NFE) decreased from 11 to 8.5 and from 48.6 to 36.5% dry wet, respectively. Fish feed COD decreased from 2.9×10^5 to 1.2×10^6 mg/l/g dry weight, whereas fish solids COD did not change significantly (from 9.6×10^6 to 7.7×10^6 mg/l/g dry weight). Ammonia concentration increase, bubbles and foam formation and wastewater decolorization were reported during the experiment. Furthermore, after 30–40 days in cold and saline water, approximately 50% of the waste matter disappeared.

A new method for fish farm wastewater treatment, based on in-tank solid separation followed by solids separation with screening, was investigated by Lekang *et al.* (2000). The system consisted of a tank with two separate outlets (a high solids concentration outlet and a low solids concentration primary outlet) and a stationary bowed screen for solid removal from the high solids effluent. The removal efficiencies of total nitrogen (TN) and total phosphorus (TP) in-tank were 7.3% and 43.2%, respectively. In-screen removal of TN, TP, COD and total solids (TS) were 42.7%, 49.3%, 48.0% and 74.4%, respectively. At the end, 3.1% TN and 21.3% TP removal rates were reported for the whole system.

Miscellaneous/multifunctional methods

Duff and van den Berg (1982) treated diluted fish processing waste using two down-flow stationary fixed film (DSFF) reactors operated side by side. The feed concentration was initially 10 kg COD/m³, then altered to 20 kg COD/m³ and finally stabilized

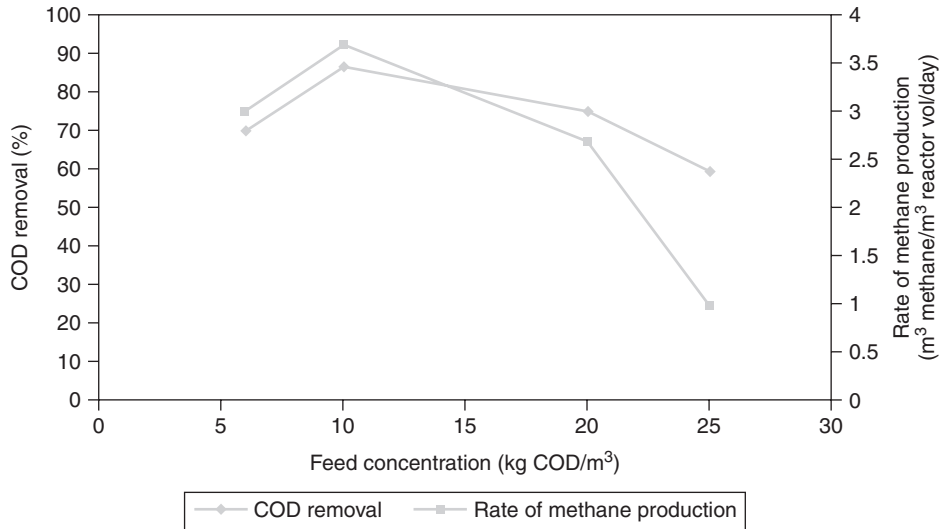

Figure 14.7 Average COD removal (%) and methane gas production rate ($\text{m}^3 \text{CH}_4/\text{m}^3$ reactor/day) at different feed concentrations ($\text{kg COD}/\text{m}^3$) (adapted from Duff and van den Berg, 1982)

at $25 \text{ kg COD}/\text{m}^3$. The temperature of each reactor was maintained at 35°C , the volatile fatty acid (VFA) concentration held below $0.50 \text{ kg}/\text{m}^3$, the loading rate ranged from 2 to $13 \text{ kg}/\text{m}^3/\text{day}$, while phosphate was added in order to keep COD:P ratio at 100:1. The results showed that COD removal varied between 60 and 92%, with the highest COD removal recorded at $20 \text{ kg COD}/\text{m}^3$ and the lowest at $25 \text{ kg COD}/\text{m}^3$. Methane production rate was $0.7\text{--}3.7 \text{ m}^3 \text{ CH}_4/\text{m}^3$ reactor/day, with the highest methane production rate observed at $10 \text{ kg COD}/\text{m}^3$ and the lowest at $20 \text{ kg COD}/\text{m}^3$ (Figure 14.7).

Lupatsch and coworkers (2003) examined the potential of using gray mullet for fish farm effluents removal. Net-cage enclosures with no bottoms were stocked with bottom-feeding gray mullet (*Mugil cephalus*), which had access to the enclosed organically enriched sediments and to particulate matter (PM) falling from the overlying cages. The fish were fed with a diet of known composition ($303 \text{ g}/\text{kg}$ crude protein and $16 \text{ MJ}/\text{kg}$ gross energy) in order to estimate the potential growth rate and energy and protein requirements of mullet. During the experiment, mullet in the enclosures consumed all the available food in the sediment and gained weight up to $0.78 \text{ g}/\text{day}/\text{fish}$. The feeding trial for energy and protein requirements for maintenance and growth revealed that mullet removed 4.2 g organic carbon, 0.70 g nitrogen and 7.5 mg phosphorus/ $\text{kg}/\text{mullet m}^2$ per day from the organically enriched sediment. Conclusively, rearing gray mullet on the organically enriched sea floor below commercial fish farms can effectively lead to the improvement of sediment status.

Herring by-products from frozen herring (*Clupea harengus*) were used for the production of crude fish oil (Aidos *et al.*, 2001). Minced herring by-products were pumped into an insulated scraped-surface heat exchanger indirectly heated by steam. The heated suspension was then separated into a three-phase decanter into a semisolid

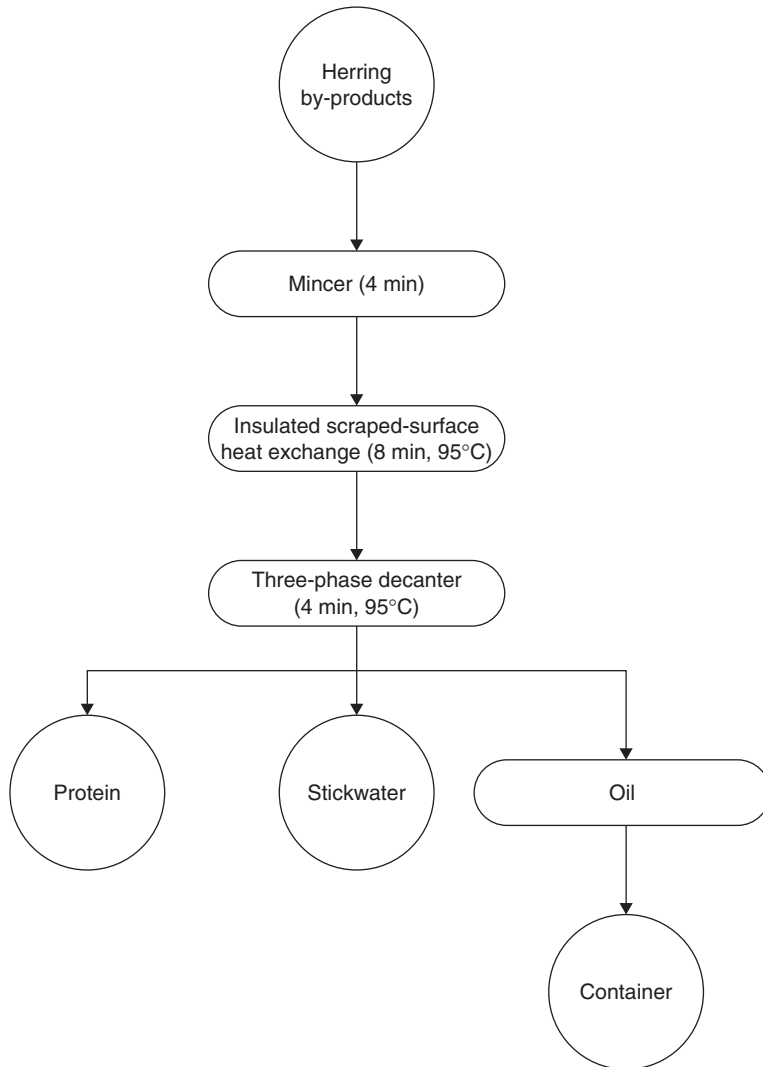

Figure 14.8 Schematic presentation of crude fish oil production from herring by-products (adapted from Aidos *et al.*, 2001)

phase (protein phase), a water phase (stickwater) and lipid phase (oil) (Figure 14.8). The produced oil was rich in valuable polyunsaturated *n*-3 fatty acids, such as EPA and DHA. Herring oil had a very low copper content (<0.1 mg/kg oil), compared to iron concentration (0.8 mg/kg oil). Maatjes herring fillets had a 32% higher copper content than by-products, whereas by-products had three times higher iron content than fillets. Furthermore, α -tocopherol and free fatty acid (FFA) concentrations remained stable over time at different storage conditions (light at room temperature, dark at room temperature, dark at 50°C).

Herring by-products (heads, frames, skin, viscera, etc.) from herring (frozen and unfrozen) marinated by-products and maatjes herring by-products (*Clupea harengus*)

were utilized as a raw material source for fish oil production according to the method of Aidos *et al.* (2001). Crude oils had a very low copper content (<0.1 mg/kg oil), in comparison to iron content that reached the levels of 0.8, 0.1 and 0.03 mg/kg oil, respectively, for oil from maatjes and frozen and fresh by-products. Free fatty acids (FFA) content of maatjes and fresh oil was low and remained almost constant, whereas an increase in FFA production for frozen oil was mentioned. Secondary oxidation products were detected in fresh oil, while tertiary oxidation products were recorded for the maatjes and frozen by-products oil. During storage, maatjes and frozen oils had an intense odor, correlating positively at the end with sensory attributes of train-oil, acidic, marine and fishy. The best oils were obtained when fresh and unsalted herring by-products were used as primary for oil extraction (Aidos *et al.*, 2003).

Two different waste treatment methods for cannery wastewater and tuna cooking liquid effluents were proposed by Garcia-Sanda *et al.* (2003). The first method involves heating and centrifugation of cannery wastewater at laboratory and industrial scale assays and the second, evaporation of tuna cooking liquid effluents at laboratory and pilot scale assays. According to the first method at laboratory scale assay, the wastewater was heated in a thermostated water bath at 70°C and centrifuged at 7500 rpm at 25°C for 20 min. At industrial scale assay, the sample was heated using heat coils and centrifuged twice for solids removal from liquid phase and oil and water separation with residual solids removal. According to the second method, a rotary evaporator operated at 60°C and 0.1 MPa and a rising film evaporator run at 108°C and 0.5 MPa were utilized for tuna effluents evaporation at laboratory and pilot scale assay, respectively. Cannery wastewater treatment resulted in generation of an oil fraction with a high percentage of carbon and hydrogen (89% by weight), absence of nitrogen, ash (0.28%) and sulfur contents (0.09%), a solid fraction (fine and thick solids) with high organic matter content (ash concentration 3.5% by weight) and moisture (72.6% by weight) and a water fraction. Important by-products were also produced, such as oil with a high calorific value (HHV) slightly lower than fuel oil no. 1 that can be utilized as a biofuel and solid fractions that can be used as a fishmeal. On the other hand, condensate obtained by the evaporation assays was characterized by its low organic matter (COD 200 mg/l) and solids content (TSS 50 mg/l) and high pH (pH 9.7). Concentrate can be used as an animal foodstuff but, due to its high salts content, the addition of protein concentrate should be below 25% by weight.

Protein and minerals removal from pink shrimp shells (*Solenocera melanthero*) were performed for chitin isolation by Chang and Tsai (1997). Sodium hydroxide (NaOH) solution was used for deproteinization of shrimp shell powder at 25 – 99°C , with 0.50–2.50 N NaOH concentration, at a ratio of NaOH to shrimp shell 5.0–20.0, for 5–360 min. Demineralization of shrimp shell powder was conducted with HCl at 30 – 100°C , with 0.20–2.00 N hydrochloric acid concentration, at a ratio of hydrochloric acid to solid 3.0–5.0 ml/g, for 5–60 min. The results revealed that the optimal conditions for deproteinization were at 75°C and 2.5 N NaOH, whereas for demineralization at 1.7 N HCl, with an acid solution to solid ratio of 9 ml/g at ambient temperature.

Frozen paste from filleting waste of silver carp (*Hypophthalmichthys molitrix*) was mixed with microbial transglutaminase (3 g/kg), dairy proteins, such as whey protein and sodium caseinate (10 g/kg) and NaCl (0, 10, 20 g/kg) for 2 min at 15°C . The sample

was placed into stainless steel tubes and sprayed with commercial regular vegetable oil. The tubes were immersed in water at 40°C for 1 h and, afterwards, at 90°C for 20 min. Then the mixture was placed in a water bath and cooled at 4–5°C for 30 min. Restructured fish products with different levels of salt (0, 1 and 2%) were obtained. The mechanical properties of fish gels increased when the salt level of the samples containing or not dairy proteins increased. On the other hand, mechanical properties of fish gels with 0 and 1% salt content increased only when dairy proteins (sodium caseinate) were utilized for filleting waste treatment (Uresti *et al.*, 2001).

Five chemical coagulation/flocculation treatments of fish canning wastewater were tested using FeCl₃ (0.4 g Fe/l) (Treatment 1), Al₂(SO₄)₃ (1.2 g Al/l) (Treatment 2), Ca(OH)₂ (0.5 g Ca/l) (Treatment 3), FeCl₃ and Ca(OH)₂ (0.4 g Fe/l + 0.2 g Ca/l) (Treatment 4), Al₂(SO₄)₃ and Ca(OH)₂ (1.2 g Al/l + 0.3 g Ca/l) (Treatment 5). BOD₅, COD, total suspended solids (TSS) and total dissolved solids (TDS) were decreased significantly up to 80–88%, 75–85%, 94–95% and 31–53%, respectively. In treatments 3, 4, and 5, total hardness increased by 61%, 319% and 419%, respectively, whereas in treatments 1, 2, 3 and 4 ammonia content decreased up to 90%, 56%, 100%, and 100%, respectively. Phosphate decreased by 90% in treatments 2 and 3 and was undetectable in treatments 1, 2 and 3. A remarkable reduction in oil and grease and total protein amounting to 73–89% and 70–92%, respectively was reported. Furthermore, maximal decrease in oil and grease was recorded in treatments 1, 2 and 4, while in protein the maximum reduction was observed in treatments 3 and 4. The best method for fish canning wastewater treatment was usage of 0.4 g Fe/l and 0.2 g Ca/l (Treatment 4) and the obtained dried precipitate contained 40% (by weight) recovered protein and 20% recovered fat (Table 14.2) (Fahim *et al.*, 2001).

Troell *et al.* (1997) evaluated the possibility of cultivating the red alga, *Gracilaria chilensis* (Gracilariales, Rhodophyta), adjacent to salmon cages, so that the plants can utilize the released dissolved nutrients. At the first station (10 m from the fish cages), the algae growth rate was up to 20–40% higher (specific growth rate 7%/day) compared to the second and third stations (150 m and 1 km distance, respectively). It was thereby shown that the growth of *Gracilaria* was favored when it was cultivated near the cages due to the release of dissolved nutrients. Close to the cages, nitrogen and phosphorus contents were higher in algal tissues (1.9–2.1 mmol N/g dw and 0.28–0.34 mmol P/g dw).

Table 14.2 Removal percentages (%) of BOD, COD, TDS, TSS, oil and grease and total protein from fish canning wastewater after five chemical coagulation/flocculation treatments

	Parameters					
	BOD (%)	COD (%)	TDS (%)	TSS (%)	Oil and grease (%)	Total protein (%)
Treatment 1	89.3	87.5	54.9	95.4	92.0	90.0
Treatment 2	87.4	88.4	34.1	95.3	84.1	81.7
Treatment 3	83.6	79.9	38.1	95.5	81.3	73.5
Treatment 4	82.3	77.3	35.3	95.7	85.3	92.8
Treatment 5	85.7	82.8	38.9	95.3	77.5	91.1

Adapted from Fahim *et al.*, 2001

Feed waste and sludge obtained during fingerling tilapia (*Oreochromis niloticus*, *Oreochromis zilonoticus* × *Oreochromis aureus*) breeding were treated through an intensive recirculating fish production system. The system consisted of patented particle traps at the bottom of a tank in order to remove feed waste and excrement, sludge collectors where the removed particles settled, a rotating screen filter for suspended solids removal, a high-rate linear-path trickling biological filter for nitrification and two downflow columns for oxygen injection (Figure 14.9). Total ammonia nitrogen (TAN) removal by the biofilter, with a single pass through the filter, was up to 65%, suspended solids (SS) removal by the sludge collectors and the screen filter were 80% and 41%, respectively and feed volatile solids (VS) removal by the sludge collectors and the screen filter was 18% (Twarowska *et al.*, 1997).

Rainbow trout (*Oncorhynchus mykiss*) raceways effluents were used for the construction of a baffled sedimentation basin. The trout effluent entered the basin which consisted of two consecutive sections (first and second) and, within the first section, four linear segments of biofiltration media were installed. Total suspended solids (TSS) removal ranged from 71 to 79% during normal conditions and from 79 to 92% during cleaning/harvesting conditions. On the other hand, doubling the basin volume and surface area caused TSS removal up to 50%. The highest removal of TSS was recorded in the first section of the basin (84% and 94% TSS removal for normal and cleaning/harvesting conditions, respectively). Furthermore, dissolved nutrients, such as total ammonia nitrogen (TAN), nitrate and nitrite, removal was observed, with the exception of orthophosphate (OP). The recorded retention times were shorter, up to 32–37% for the first section and 17–27% for the overall basin, compared to theoretical values. Finally, an increase in hydraulic efficiency with an increase in L:W (length:width) ratios was reported (Stewart *et al.*, 2006).

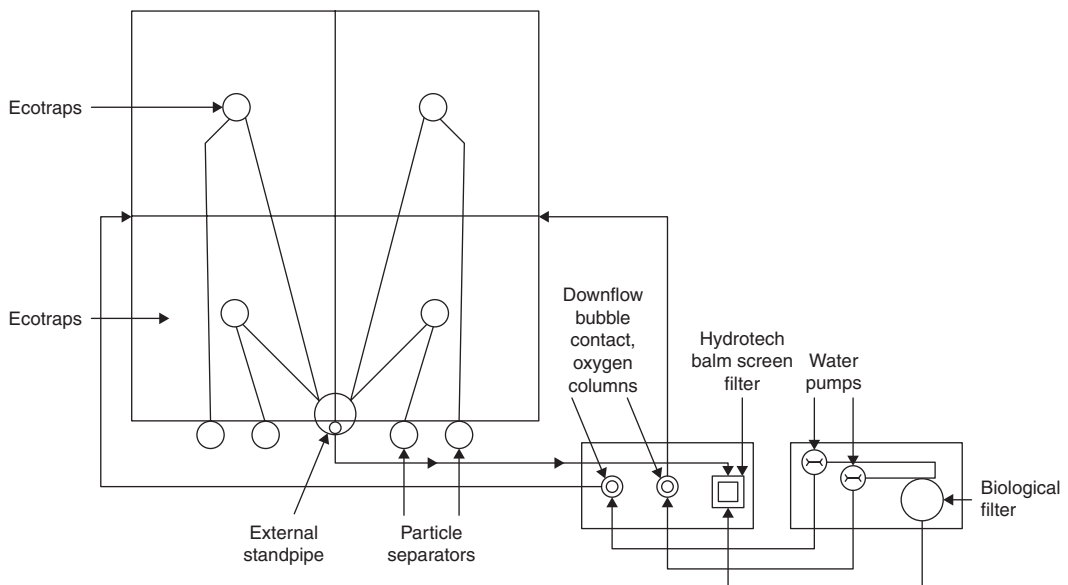

Figure 14.9 Top view of an intensive recirculating fish production system (adapted from Twarowska *et al.*, 1997)

A laboratory-scale activated sludge unit was operated for nitrification and COD removal from fishmeal factories wastewater after their treatment in an anaerobic digester. The samples were fed into the unit and the temperature was maintained at $17 \pm 0.8^\circ\text{C}$ and the dissolved oxygen concentration was kept at 1–4 mg/l. The unit was operated for 16 days with synthetic wastewater that was progressively replaced with industrial wastewater and, after the 16th day, it was fed only with industrial wastewater. The results displayed that COD and TKN removal reached 1.5 g COD/g VSS/day and 0.25 g N/g VSS/ day, respectively and complete hydrolysis of organic nitrogen to ammonia. The COD removal ranged from 95% to 60%, whereas the percentage of nitrified TKN dropped from 65% to 20% (Figure 14.10). Nitrite and nitrate were also produced, while ammonia oxidation was inhibited by free ammonia concentration (Garrido *et al.*, 1998).

Batista (1999) examined the potential recovery of proteins from hake (*Merluccius* spp.) and monkfish (*Lophius* spp.) waste with chemical extraction and precipitation. Fish 'sawdust' from hake and monkfish, in a form of a thick paste, was added to an aqueous solution containing HCl or alkali (NaOH or $\text{Ca}(\text{OH})_2$). The first extract obtained with NaOH was precipitated with HCl and the second with $\text{Ca}(\text{OH})_2$ with H_3PO_4 . Then the supernatant protein solutions were treated with sodium hexametaphosphate ($\text{Na}_6(\text{PO}_3)_6$). The effect of pH, type of aqueous solution used (NaOH or $\text{Ca}(\text{OH})_2$), ionic strength (concentration of NaCl), ratio of extracting media to raw material and temperature on the percentage of protein extracted and $\text{Na}_6(\text{PO}_3)_6$ concentration on the recovery of soluble proteins was also examined. Protein solubility was lower at pH 5.0–6.0 for hake waste, and at pH 5.0 for monkfish waste, whereas protein recovery was higher at pH 2.0–4.0. An increase in the ratio of extracting media

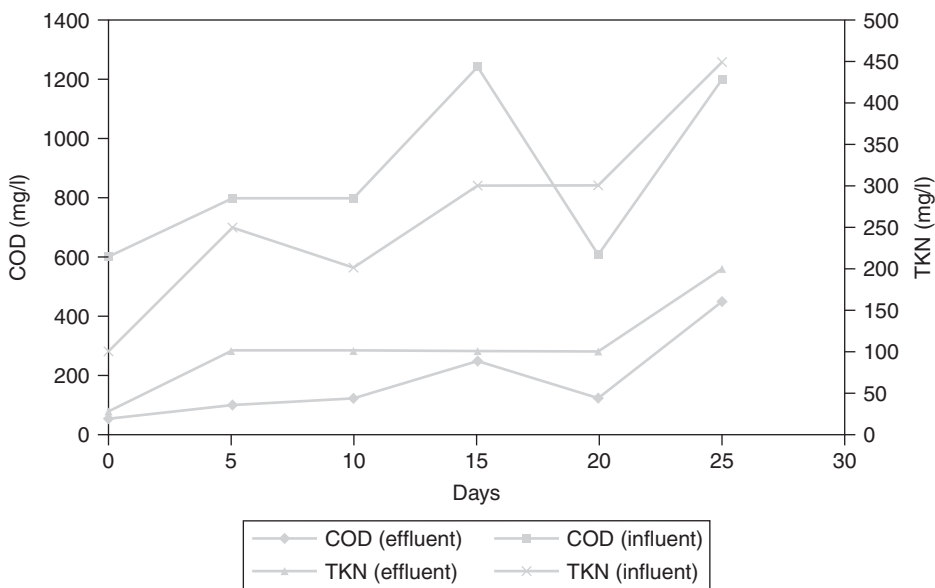

Figure 14.10 Evolution of the COD and TKN versus time in the influent and effluent (adapted from Garrido *et al.*, 1998)

to raw material promoted an increase in extraction yields of both species, especially when NaOH was used for chemical extraction of proteins. The amount of extracted protein augmented with temperature, even though the increase was more pronounced when NaOH was added to the fish pastes. Protein extraction at pH 2, 4 and 11 augmented with higher NaCl concentration, whereas protein solubility increased when the ionic strength reached neutral pH.

Organic wastes from a fish (cod) enclosure were dispersed with lipid biomarkers, using sediment traps to collect settling matter. Sediment traps were placed 1.5 m away from the seafloor at distances of 5, 10, 30 and 100 m from the cages in a transect out of the cove. The samples taken from the traps and the feed (whole herring) were frozen, transported to the laboratory and stored at -20°C in chloroform and under nitrogen until analysis. Lipids were extracted from the samples with a mixture of chloroform:methanol. The major lipid classes detected were: phospholipids (21–10%), acetone mobile polar lipids (17–42%), free fatty acids (8–41%) and, in smaller amounts, triacylglycerols (4–9%), sterols (5–10%), wax esters and sterol esters (0–11%), alcohols (0–5%) and hydrocarbons (3–5%). On the other hand, the major fatty acids detected were: 14:0 (6–9%), 16:0 (17–22%), 16:1 ω_7 (12–21%), 18:1 ω_7 (6–7%), 18:1 ω_9 (5–10%), 20:5 ω_3 (7–11%) and 20:3a (0–9%). The three long-chain monounsaturated fatty acids 20:1 ω_9 , 22:1 ω_9 and 22:1 ω_{11} were found at proportions below 3% and were at high levels close to the pens and decreased moving away from the pens. The feed was rich in fatty acids 20:1 ω_9 and 22:1 ω_{11} , which were not digested by cod and other fish, thus resulting in utilization as biomarkers for the dispersion of organic waste from fish farms (Van Biesen and Parrish, 2005).

Four outdoor systems, such as retention lagoon in commercial farms (Atlantic coasts of France), foam fractionation in extensive systems (Italian fish pond culture), microalgae (*Skeletonema costatum*) production and oyster (*Crassostrea gigas*) filtration in intensive systems (sea bass farm, *Dicentrarchus labrax*) were tested for their efficiency in aquaculture effluents treatment prior to discharge or recycling. Each treatment was efficient for a specific parameter: retention lagoon for particulate material, foam fractionation for dissolved organic material, microalgae and bivalve filter feeders for mineral nutrients and phytoplankton. A combination of these treatments is the best way to ensure aquaculture effluents purification. Foam fractionation coupled with aeration and water circulation is one of the best approaches towards treating and recirculating wastewaters in extensive systems (Hussenot *et al.*, 1998).

Table 14.3 provides a synoptical presentation of the most important treatment methods (parameters, quality control and results).

The advantages and disadvantages of various methods for fish waste treatment are presented in Table 14.4.

Uses of fish waste

Food industry wastes are an important environmental contamination source. Research has been carried out in order to develop methods to convert these wastes into useful

Table 14.3 Various treatment methods of fish waste: parameters, quality control and results

No	Kind of waste	Treatment	Parameters	Methodology	Quality control methods	Results	References
<i>A Hydrolysis</i>							
1	Fish meat	Hydrolysis of fish meat under subcritical and supercritical conditions	Organic acids, amino acids, TOC, carbon, nitrogen, hydrogen	Fish meat liquefaction with hydrolysis in a reactor under subcritical (10 kg fish meat, $3.36 \times 10^{-6} \text{ cm}^3$ Milli-Q water) and supercritical (10^{-3} kg fish meat) 3.06×10^{-6} (280°C , 30 MPa)	1 Organic acids, amino acids: HPLC 2 TOC: TOC analyzer 3 Carbon, nitrogen, hydrogen: CHN corder	1 Formation of lactic acid (0.03 kg/kg of dry meat), phosphoric acid (0.12 kg/kg of dry meat) and histidine (0.01 kg/kg of dry meat) (200°C , 3.35 MPa, 5 min) 2 Production of pyroglutamic acid (0.095 kg/kg of dry meat) (280°C , 6.42 MPa, 30 min) 3 Production of amino acids (cystine, alanine, glycine, and leucine) (270°C , 5.51 MPa) 4 Oil extraction (rich in EPA and DHA) 5 Formation of amino acids (cystine, alanine, and glycine) and organic acids (pyroglutamic acid) ($200\text{--}400^\circ\text{C}$, 5 min)	Yoshida <i>et al.</i> , 1999, 2000
2	Minced salmon muscle	Enzymatic hydrolysis	Protein, moisture content, total mineral content, lipid content, nitrogen recovery, emulsifying capacity, emulsifying stability, fat absorption/oil-holding capacity	Homogenized minced salmon muscle treated with one of four alkaline proteases (Alcalase 2.4L, Flavorzyme 1000L, Corolase PN-L, and Corolase 7089) or endogenous digestive proteases ($\text{pH } 7.5$, 40°C , 7.5% protein).	1 Protein: using a modified $\text{CuSO}_4/\text{TiO}_2$ mixed catalyst Kjeldahl method according to method 4.2.03 (AOAC, 1990) 2 Moisture content: convectionless oven method 24.003 (AOAC, 1990) 3 Total mineral content: direct ash method 14.006 (AOAC, 1990) 4 Lipid content: modified acid hydrolysis method 948.15 (AOAC, 1990)	1 Protein content ranged from 71.7 to 88.4% 2 Low lipid content 3 Nitrogen recovery ranged from 40.6 to 79.9% 4 High hydrolysates solubility at high pH ($\text{pH } 7$) 5 Hydrolysates solubility ranged from 92.4 to 99.7% 6 Fish protein emulsification capacity was 75–299 ml of oil emulsified per 200 mg of protein	Kristinsson and Rasco, 2000a, b

(Continued)

Table 14.3 (Continued)

No	Kind of waste	Treatment	Parameters	Methodology	Quality control methods	Results	References
					5 Nitrogen recovery: calculated as the amount of protein (%N × 6.25) present in the hydrolysates relative to the initial amount of protein present in the reaction mixture	7 Fish protein emulsification stability was 50–70% 8 Greater fat absorption at 5 and 10% DH fish protein hydrolysates (3.22–5.90 ml of oil/g of protein) than for 15% hydrolysates	
					6 Emulsifying capacity: oil titration method similar to that of Webb <i>et al.</i> (1970) with some modifications		
					7 Emulsifying stability: method of Yatsumatsu <i>et al.</i> (1972) as modified by Miller and Groninger (1976) with some additional modifications		
					8 Fat absorption/oil-holding capacity: method of Shahidi <i>et al.</i> (1995) with some modifications		
3	Shrimp waste (heads and scales)	Protein hydrolysis by a commercial protease (Alcalase)	Dry weight, ash, total N, crude protein, lipid, astaxanthin, amino acids, phenyl-thiocarbamoyl, chitosan viscosity	A protease (Alcalase) was added to diluted shrimp waste and the sample was hydrolyzed for 2 h at 40°C in an open stirred reactor. Solid tissues and crude hydrolysate separation by pressing. The obtained press cake processed to chitosan by demineralization, deproteinization,	1 Dry weight: drying for 2 days at 105°C 2 Ash: heating to 550°C for 20 h 3 Total N and crude protein: Kjeldahl procedure 4 Lipid content: Soxhlet extraction with petroleum benzene 5 Astaxanthin: method of Skrede and Storebakken (1986)	1 68.5% total recovery of Kjeldahl nitrogen 2 33.2% total dry matter retrieval 3 Chitosan isolation 4 Protein hydrolysates rich in amino acids – potential use as feed in salmonid fish or microorganisms	Gildberg and Stenberg, 2001

				deacetylation and drying	6 Amino acids: hydrolysis (6 N HCl, 24 h, 110°C) under nitrogen pressure 7 Phenyl-thiocarbamoyl derivatives: HPLC reverse-phase chromatography and recorded by UV absorption at 254 nm 8 Chitosan viscosity: viscosimeter		
4	Fish wastes (heads and bony parts)	Acid hydrolysis	Glucose, lactic acid, total nitrogen, cell nitrogen, dry weight	<i>Process A:</i> Minced wastes mixed with water (1:1 ratio) (pH 1) was hydrolyzed at 121°C for 20 min and centrifuged at 2706 g for 20 min <i>Process B:</i> Process A plus fish wastes pretreatment (an extraction by water at 121°C for 20 min)	1 Glucose and lactic acid: HPLC with refractive index detector (for glucose) and with a UV/VIS detector at 210 nm (for lactic acid) 2 Total nitrogen: elementary analyzer 3 Cell density: spectrophotometer at 660 nm 4 Dry weight: drying in an oven at 104°C	1 Lactic acid production by both processes 2 Process B increased lactic acid productivity by 22% 3 Fish waste hydrolysate (produced by Process B) can be used as a substitute for yeast extract	Gao <i>et al.</i> , 2006
5	Shrimp shells	Hydrothermal treatment	Amino acids, acetic acid, organic acid	Treatment of shrimp shells at batch reactor apparatus in high temperatures (90–400°C), high pressure water (45 MPa) and various reaction times (5–60 min)	1 Amino acids: amino acids analyzer 2 Acetic acid: organic acid analyzer 3 Organic acid: system consists of an ion-exclusion column and an electroconductivity detector	1 Maximum production of amino acids (70 mg/g of dry shrimp shell) at 250°C in 60 min 2 Production of Gly and Ala increased with increasing temperature, but decreased at temperatures above 250°C	Quitain <i>et al.</i> , 2001
<i>B Bioremediation</i>							
6	Fish waste	Fermentation process using <i>Aspergillus awamori</i>	Dry matter (DM), crude protein (CP), lipid, ash, fiber content, glucoamylase, acidic protease activity, released tyrosine	Wheat bran (700 g), minced fresh sardines (2638 g) and <i>A. awamori</i> spores (0.7 g) mixed together and kept in a ventilated incubator for 5 days at 40°C	1 DM, CP, lipid, ash and fiber content: proximate chemical analysis (AOAC, 1984) 2 Glucoamylase: using kits 3 Acidic protease activity: using casein as a substrate	1 Decrease of crude protein, fat and nitrogen-free extracts up to 2.6, 22.2 and 25.7%, respectively 2 16.1% increase of crude fiber 3 Production of glucoamylase (9.71 U), α -glucosidase (0.21 U),	Yamamoto <i>et al.</i> , 2005

(Continued)

Table 14.3 (Continued)

No	Kind of waste	Treatment	Parameters	Methodology	Quality control methods	Results	References
7	Crab-processing waste	Fermentation	Trimethylamine (TMA), nitrogen, dry matter (DM), ash, pH, lactic acid, water-soluble carbohydrates (WSC)	<p><i>Treatment A:</i> Mixture of 1.5% propionic/formic acid (1:1) and crab-processing waste ensiled with wheat straw, sugarcane molasses and water (32:32:16:20, wet basis) with or without 0.1% microbial inoculant (<i>Streptococcus faecium</i> and <i>Lactobacillus plantarum</i>)</p> <p><i>Treatment B:</i> Application of either 0.2% sodium hypochlorite (NaOCl) or 0.4% hydrogen peroxide (H₂O₂) to crab waste. Ensiling of the mixture as described in Treatment A</p> <p><i>Treatment C:</i> Treatment of crab waste with 1% sodium nitrite (NaNO₂) or 0.2% and 0.4% NaOCl/calcium hypochlorite [Ca(OCl)] or 1% NaNO₂ to crab waste. Ensiling of the mixture as described in Treatment A</p>	<p>4 Released tyrosine: photometrically at 660 nm</p> <p>1 Trimethylamine (TMA): colorimetric procedure (Dyer, 1959) after extraction with 7.5% trichloroacetic acid</p> <p>2 Nitrogen: Kjeldahl method (AOAC, 1984)</p> <p>3 Dry matter (DM): drying in a forced draft oven at 60°C for 48 h</p> <p>4 Ash: (AOAC, 1984)</p> <p>5 pH: electrometrically</p> <p>6 Lactic acid: method of Barker and Summerson (1941) (modified by Pennington and Sutherland, 1956)</p> <p>7 Water-soluble carbohydrates (WSC): of Dubois <i>et al.</i> (1956) (adapted to corn plants by Johnson <i>et al.</i>, 1966)</p>	<p>α-amylase (21.69 U) and acidic protease (17 778 U)</p> <p>4 CP content remained stable</p> <p><i>Treatment A:</i> 1 Prevention of waste degradation for up to 14 days 2 pH and water-soluble carbohydrates (WSC) decrease 3 Lactic acid increase</p> <p><i>Treatment B:</i> 1 Prevention of deterioration up to 7 days 2 Trimethylamine (TMA) concentration increase (from 3.70 to 12.85 mg of N/100 g) for NaOCl treated waste 3 Trimethylamine (TMA) concentration increase (from 3.70 to 12.85 mg of N/100 g) when treated with NaOCl and remained stable (from 2.66 to 2.71 mg of N/100 g) when treated with H₂O</p> <p><i>Treatment C:</i> 1 Preservation of waste for a minimum of 10 days 2 Detection of ammonia gas at day 12 3 No detection of H₂S at day 15</p>	Ayangbile <i>et al.</i> , 1997
8	Bonito waste (flesh body, head, fins and	Fermentation	pH, protein, reducing sugar, total sugar,	Different combinations of fish body parts with or without the addition	1 pH and protein: standard methods (AOAC, 1984)	1 Higher total sugar content (10.8–17.4 mg/l) and amylase activities	Shih <i>et al.</i> , 2003

	viscera)		trimethylamine (TMA), volatile basic nitrogen (VBN), free amino acids, color, volatile compounds	of enzymes (viscera, soybean koji or ang-khak) were inoculated into a porcelain vase for fermentation	<ol style="list-style-type: none"> 2 Reducing sugar and total sugar: Miller's method (Miller, 1959) and phenol-sulfuric method (Dubois <i>et al.</i>, 1956), respectively 3 Trimethylamine (TMA) and volatile basic nitrogen (VBN): Castell <i>et al.</i>'s method (Castell <i>et al.</i>, 1974) and Cobb <i>et al.</i>'s method (Cobb <i>et al.</i>, 1973), respectively 4 Free amino acids: amino acid analyzer 5 Color: color measuring system 6 Volatile compounds: GC 	<p>(5.0–100 U/ml) of soybean koji and ang-khak treated bonitos</p> <ol style="list-style-type: none"> 2 Lower total sugar content (3.6–5.9 mg/l) and no detection of amylase activities of treated bonitos without the addition of enzymes 3 Volatile basic nitrogen (VBN) and trimethylamine (TMA) exceed thresholds of 6 mg/100 g and 50 g/100 g (except for treatments 1 and 3) 	
9	Fisheries processing waste	Fermentation	Ash, carbohydrates, lipids, protein, biomass concentration	Composting with peat in a passively aerated composting system. Compost extracts were used as a substrate for <i>Scytalidium acidophilum</i> ATCC 26774 (agitation speed of 150 rpm, temperature of 25.0°C, pH of 2.0 ± 0.1 and cultivation time 8–10 days)	<ol style="list-style-type: none"> 1 Ash: combustion in a muffle furnace at 600°C 2 Carbohydrates: anthrone reagent method presented by Morris (1948) 3 Lipids: method described by Folch <i>et al.</i> (1957) 4 Protein: multiplying the nitrogen, found by AOAC Micro-Kjeldahl Method 47.021 (Anon., 1980) by the factor 6.25 5 Biomass concentration: procedure of Martin <i>et al.</i> (1990) 	<ol style="list-style-type: none"> 1 Acid extracts of compost had higher concentrations of nutrients (lipids, carbohydrates, and protein) than compost 2 Fish wastes – peat compost: inexpensive nutrient source for fermentation processes 3 Substrate for the growth of acid-tolerant fungus <i>S. acidophilum</i> 4 Used for the biofiltration of liquid and gas effluents and in the growth of mushrooms 	Martin, 1999

(Continued)

Table 14.3 (Continued)

No	Kind of waste	Treatment	Parameters	Methodology	Quality control methods	Results	References
10	Seafood processing wastes	Fermentation	Dry matter (DM), nitrogen, ash, Mg, Ca, phosphorus, carbohydrate	<p>1 <i>Small silo experiments</i> 1st experiment: Seafood waste ensiled with corn stover or peanut hulls (DM levels 40–60%), alone and with 5% dry molasses or 1% formic acid</p> <p>2nd experiment: Crab waste and corn stover ensiled (40: 60 and 60: 40 (w/w) and dry molasses (5%) was also added</p> <p>2 <i>Large silo experiments</i> Fish and crab processing wastes ensiled with wheat straw (preparations of fish waste and straw 70: 30 and 51: 49, crab waste and straw 60: 40 and 40: 60 (w/w), wet basis). Dry molasses (5%) and acetic acid (16%, v/w) were also added</p>	<p>1 Dry matter (DM): drying duplicate 200 g samples in a forced-draft oven at 60°C for 48 h, ground and analyzed for DM and ash (AOAC, 1980)</p> <p>2 Nitrogen: Kjeldahl method (AOAC, 1980)</p> <p>3 Ash: method of Sandel (1950)</p> <p>4 Mg and Ca: atomic absorption spectroscopy</p> <p>5 Phosphorus: method of Fiske and Subbarow (1925)</p> <p>6 Carbohydrate: water extracts were determined (Dubois <i>et al.</i>, 1956)</p>	<p>1 <i>Small silo experiments</i> 1 All silages had desirable aroma (except those with crab waste ensiled at 40 and 50% DM)</p> <p>2 Average pH for mixtures with fish waste was 6.5, while in mixtures with crab waste the pH was 8.0</p> <p>3 Low levels of colifonns and fecal coliforms by ensiling</p> <p>2 <i>Large silo experiments</i> 1 Mixtures of ensiled fish waste and straw showed decrease in pH (pH <5.0)</p> <p>2 The lower the proportion of fish waste the higher the decrease of pH</p> <p>3 Absence of lactic acid in crab waste-straw mixtures</p>	Samuels <i>et al.</i> , 1992
11	Fish processing waste (offal)	Composting of fish waste with sawdust and wood shavings using static aerated piles	pH, electrical conductivity (EC), ammonium as nitrogen (NH ₄ ⁺ -N), water-soluble carbon (WSC), total organic carbon (TOC), total N (TN) and volatile fatty acids (VFA)	Fish offal was mixed with the bulking agent (a blend of sawdust and wood shavings 1:1 by volume) (3:1 wet weight ratio). The mixture was placed in the reactors and remixed after 20 days and reloaded in the reactors (temperature above 45°C, duration 150 days) (the	<p>1 Electrical conductivity, pH, NH₄⁺-N and WSC: mechanically shaking of the samples with distilled water (1:10 ratio) for 2 h and filtering through Whatman N° 1 filter paper</p> <p>2 Ammonium: indophenol-blue method</p> <p>3 WSC (as chemical</p>	<p>1 Decrease of EC, NH₄⁺-N, WSC</p> <p>2 Decrease of VFA to non-detectable levels after 80 days, with exception of acetic values</p> <p>3 WSC/TN= 0.7 (summer): compost is mature in 150 days</p> <p>4 WSC/TN= 1.2 (winter): additional days would be needed for the</p>	Laos <i>et al.</i> , 2002

				experiment was carried out in winter and summer)	oxygen demand (COD)); wet acid digestion, followed by spectrophotometric determination (APHA, 1992)	compost to achieve maturity	
12	Crab waste	Ensiling of crab waste and wheat straw treated with different additives	pH, lactic acid, water-soluble carbohydrates (WSC), volatile fatty acids (VFA), trimethylamine, dry matter, Kjeldahl nitrogen, neutral detergent fiber (NDF), acid detergent fiber (ADF), lignin, cellulose, ash, hemicellulose	<p>1 <i>Small silo experiments</i> Experiment 1: Crab waste and wheat straw (1:1, wet basis) were ensiled with 0–20% dry molasses, 0–0.1% microbial silage inoculant and 0–5.4% phosphoric acid or 0–20% water</p> <p>Experiment 2: 10–20% dry molasses, 0 or 0.1% microbial silage inoculant and 0 or 20% water were added to crab waste and wheat straw (1:1, wet basis) mixture</p> <p>2 <i>Large silo experiments:</i> Crab waste and wheat straw (1:1 proportions) were ensiled with 20% dry molasses, 20% dry molasses and 0.1% microbial silage inoculant and 16% glacial acetic acid</p>	<p>1 pH: electrometrically</p> <p>2 Lactic acid: Barker and Summerson (1941) as modified by Pennington and Sutherland (1956)</p> <p>3 Water-soluble carbohydrates (WSC): Dubois <i>et al.</i> (1956), as adapted for corn plants by Johnson <i>et al.</i> (1966)</p> <p>4 Volatile fatty acids (VFA): GC</p> <p>5 Trimethylamine: according to a colorimetric procedure (Dyer, 1959) after extraction in 7.5% trichloroacetic acid</p> <p>6 Dry matter: by drying duplicate 200-g samples in a forced draft oven at a maximum of 60°C for 48 h. The samples were analyzed for DM and ash (AOAC, 1980)</p>	<p><i>Small silo experiments:</i></p> <p>1 Higher pH (pH 7.34–7.36) at mixtures without added molasses or acid (Experiment 1)</p> <p>2 Lower TMA (8.11–18.84% dry matter) for molasses – and inoculant – treated silages (Experiment 1)</p> <p>3 Lactic acid levels increased and pH decreased linearly with increasing levels of molasses (Experiment 2)</p> <p>4 Higher VFA, acetic, propionic and isobutyric acid concentrations in mixtures with added water and molasses</p> <p>5 10–20% dry molasses to crab-straw mixtures before ensiling resulted in substantial amounts of lactic acid</p> <p><i>Large silo experiments:</i> Lower pH (pH 4.70) and higher lactic acid</p>	Abazinge <i>et al.</i> , 1993

(Continued)

Table 14.3 (Continued)

No	Kind of waste	Treatment	Parameters	Methodology	Quality control methods	Results	References
					7 Kjeldahl nitrogen (N): was determined on wet silage samples (AOAC, 1980)	concentration (12.76% dry matter) for ensiled mixtures with added 20% molasses and 0.1% inoculant, compared to molasses alone	
					8 Neutral detergent fiber (NDF): Van Soest and Wine (1967)		
					9 Acid detergent fiber (ADF): Van Soest (1963)		
					10 Lignin and cellulose: Van Soest and Wine (1968)		
					11 Ash: AOAC (1980)		
					12 Hemicellulose: was determined by difference (NDF - ADF)		
13	Fish waste	Valorization	pH, dry matter, ash, fat, total nitrogen (TN), non-protein-nitrogen (NPN), total volatile nitrogen (TVN), trimethylamine (TMA), reducing sugars	Fish waste-molasses mixture was inoculated at 28°C for 10 days with strains of yeasts (32 strains of yeasts <i>Saccharomyces cerevisiae</i> and <i>Candida</i> spp. and 14 strains of lactic acid bacteria <i>Lactobacillus plantarum</i> and <i>Pediococcus acidilactici</i>) and fermented at different values of pH (4.0–5.8), temperature (20–30°C) and molasses proportions (20–30%, w/w)	1 pH: pH-meter 2 Dry matter: oven drying at 105°C 3 Ash: ignition at 550°C 4 Fat: Soxhlet extraction with hexane 5 Total nitrogen (TN): Kjeldahl method (APHA, 1989) 6 Non-protein-nitrogen (NPN): Kjeldahl method after precipitation with a 2% trichloroacetic acid solution 7 Total volatile nitrogen (TVN): method described by Conway (1974) 8 Trimethylamine (TMA): method described by	1 Suitable conditions for fermentation were: 30% molasses at pH 5.0–5.4 and at 26–30°C 2 Final product free of coliforms and <i>Salmonella</i> 3 Decrease of pH (16.3–17.3%), dry matter (1.9–18.6%), RS (12.4–46.4), protein (0–16.3%), TN (4.0–18.8%) TMA content (55.0–82.6%) 4 Considerable increase of ash, fat, NPN, TVN	Faid <i>et al.</i> , 1994

14	Fish waste (offal, scales, gills, washing water)	Anaerobic batch co-digestion of sisal pulp and fish waste	Partial alkalinity (PA), total alkalinity (TA), pH, TS, VS, total nitrogen, total lipids, organic carbon	Batchwise digestion of sisal pulp and fish waste separately (25 and 29 days, respectively) and with mixtures in various proportions (24 days) in bioreactors at $27 \pm 1^\circ\text{C}$	<p>Murray and Gibson (1972)</p> <p>9 Reducing sugars: Bertrand method</p> <p>1 Partial alkalinity (PA), total alkalinity (TA), pH: TIM titration manager with an ABU 901 Autoburette (Bjornsson <i>et al.</i>, 2000)</p> <p>2 TS, VS: APHA Standard Methods (APHA, 1995)</p> <p>3 Total nitrogen: Kjeldahl method</p> <p>4 Total lipids: Soxhelt extraction using petroleum ether solvent extraction (APHA, 1995)</p> <p>5 Organic carbon: dichromate oxidation method (Nelson and Sommer, 1996)</p>	<p>1 Digestion of sisal pulp and fish waste separately: 0.32 and 0.39 m³ methane/kg VS, respectively</p> <p>2 Highest methane yield (33% fish waste and 67% sisal pulp): 0.62 m³ methane/kg VS</p> <p>3 Co-digestion sisal pulp and fish waste: biogas production (60–65% methane content)</p>	Mshandete <i>et al.</i> , 2004
15	Fishmeal process wastewater	Anaerobic treatment in a UASB reactor at high pH	VFA, methylamines, COD, total solids (TS), VS, volatile suspended solids (VSS), pH, ammonia concentrations, specific methanogenic activity (SMA)	The fish condensate (pH 7.0–7.3) was fed in the reactor for 1 year (pH 7.3–7.9, organic loading rate 10 and 16 g COD/l day). Batch experiments were also conducted in order to determine the specific methanogenic activity (SMA) at pH 7.1–8.5	<p>1 VFA: GC equipped with a flame ionization detector (FID)</p> <p>2 Methylamines: GC equipped with an FID detector</p> <p>3 COD: dichromate oxidation according to standard methods (American Public Health Association, 1975)</p> <p>4 Total solids (TS), VS, volatile suspended solids (VSS) and pH: standard methods (American Public Health Association, 1975)</p>	<p>1 >99% of volatile fatty acids and trimethylamine were degraded at pH 7.9</p> <p>2 pH >8.0: 15–17% COD removal</p> <p>3 pH > 7.9: slight decrease of acetate conversion</p> <p>3 pH > 8.3: serious disintegration of the granules</p> <p>4 Increased pH resulted in decrease of density (from 1067 g/l to 1017 g/l), size (less than 0.4 mm), total solids (from 114.5 g TS/l to 55.1 g TS/l) and volatile solids content (from 39.2 g VS/l to 11.2 g VS/l)</p>	Sandberg and Ahring, 1992

(Continued)

Table 14.3 (Continued)

No	Kind of waste	Treatment	Parameters	Methodology	Quality control methods	Results	References
					5 Ammonia concentrations: Kjeldahl method 6 Specific methanogenic activity (SMA): batch experiments performed in 58-ml vials containing 20 ml fish condensate incubated at 34°C	5 After 4 months of acclimatization to high pH the specific methanogenic activity of the granular biomass was the same from pH 7.1 and 8.5 (1.3–1.8 g COD g/VS/day) 6 At pH 8.3 and 8.5, acclimatization improved the specific activity by 25 and 50%, respectively 7 Acclimatized biomass showed a decreased activity (60%) at all pH values	
16	Marine fish waste, commercial freshwater fish waste, and tilapia filleting residue	Acid digestion (formic acid and sulfuric acid) and anaerobic fermentation (<i>Lactobacillus plantarum</i> , sugarcane molasses)	Crude protein, amino acid composition	Saltwater (SW), commercial freshwater fish waste (FW), and tilapia filleting residue (TR) were mixed with 15% sugarcane molasses, 5% <i>Lactobacillus plantarum</i> and 0.25% sorbic acid (w/w) (fermented silage), while 2% formic acid (w/v) and 2% sulfuric acid (w/v) (acid silage) were added to the mixture	1 Crude protein: micro-Kjedahl method, according to AOAC-code 981.10 (1990) 2 Amino acid composition: liquid chromatography, using a cationic exchange resin column and ninhydrine post-column derivation in auto-analyzer	1 Acid silages: higher protein content 69.91% (SW), 44.38% (FW) and 39.59% (TR) compared to fermented silages, 59.61% (SW), 42.09% (FW) and 35.84% (TR), respectively 2 Increase in histidine, threonine and serine levels, for both processes and all three raw materials used 3 Decrease of valine, isoleucine and leucine in all products 4 All products can be used in balanced fish diets – nutritional value	Vidotti <i>et al.</i> , 2003
<i>D Filtration/screening</i>							
17	Fish wastewater	Underwater filtration	Total suspended matter (TSM), BOD ₅ , coliform-bacteria concentrations	Marine underwater depuration system (MUDS) consisting of a percolating filter was placed at sea over an	—	1 90% reduction in TMS, BOD ₅ and coliform bacteria concentrations 2 Development of protozoan and	Cattaneo-Vietti <i>et al.</i> , 2003

				urban sewage outflow of a submarine pipeline		microbenthic communities, increasing the depuration efficiency of the system and the consumption of the organic matter	
						3 Predators (such as detritus feeder invertebrates and benthic and pelagic fishes) attraction, resulting in organic matter re-cycling	
						4 Development of fish, aggregation of fish species	
						5 Selection of marine organisms (bacteria, fungi, protozoans) causing changes in salinity and temperature	
18	Aquaculture wastewater	Filtration followed by treatment by polyethersulfone (PES) membranes	Total ammonium, total phosphorus	Aquaculture wastewater obtained after sand filtration treatment passed through polyethersulfone (PES) membranes, which were prepared by using a dry/wet phase inversion technique	Total ammonium and total phosphorus: standard method and digestion technique by using spectrophotometer at 880 and 640 nm, respectively	High removal of total ammonium and total phosphorus up to 85.70 and 96.49%, respectively at pressure 0.4–0.8 MPa	Ali <i>et al.</i> , 2005
19	Solid waste and fish feed	Degradation rate experiments	Dry mass, ash, total carbon, nitrogen, sulfur content, COD, carbohydrates, lipids, protein content	Frozen samples (–10°C) were placed in tank filled with saline (25–30% salinity) and distilled water and kept in the dark at 8°C and oxygen concentration >80%	<ol style="list-style-type: none"> 1 Dry mass and ash: Standard Methods for the Examination of Water and Wastewater (American Public Health Association, 1998) 2 Total carbon, nitrogen and sulfur content: by the UBC Earth and Ocean Sciences Laboratory with a Carlo Erba N2A-1500 Analyzer 3 COD: pre-packaged mercury-free standard range digestion kit 	<ol style="list-style-type: none"> 1 C/N and nitrogen-free extracts (NFE) decreased from 11 to 8.5 and from 48.6 to 36.5% dry wet, respectively 2 Fish feed COD decreased from 2.9×10^5 to 1.2×10^6 mg/l/g dry weight 3 Fish solids COD remained stable (from 9.6×10^6 to 7.7×10^6 mg/l/g dry weight) 4 50% waste matter degradation after 30–40 days in cold and saline water 	Buryniuk <i>et al.</i> , 2005

(Continued)

Table 14.3 (Continued)

No	Kind of waste	Treatment	Parameters	Methodology	Quality control methods	Results	References
20	Fish farm wastewater	Treatment in dual-drain tanks	Total phosphorus (TP), total nitrogen (TN), COD, total solids (TDM), TSS	In-tank solid separation from the high solids effluent, followed by solids separation by screening	<p>4 Carbohydrates and lipids: assumed to be the nitrogen-free extract (NFE) (sample minus ash and protein)</p> <p>5 Protein content: calculated from total nitrogen content after multiplying the total nitrogen content by 6.25</p> <p>1 TP, TN, COD and TDM: analytical methods (Norwegian Standard)</p> <p>2 TSS: immediate filtration after sampling</p>	<p>5 Ammonia concentration increase, bubbles and foam formation, wastewater decolorization</p> <p>1 0% TN and 7.3% TP removal for the particle outlet</p> <p>2 49.3% TP, 42.7% TN, 48.0% COD and 74.4% TS removal for the bowed screen</p> <p>3 21.3% TP and 3.1% TN waste removal for the whole system</p>	Lekang <i>et al.</i> , 2000
<i>E Miscellaneous/multifunctional methods</i>							
21	Fish farm effluents	Removal efficiency of fish farm effluents by gray mullet	Nitrogen, dry matter, ash, protein, total phosphorus, total carbohydrate, gross energy, organic carbon	Use of the bottom-feeding gray mullet (<i>Mugil cephalus</i>) within benthic enclosures as a means to reduce the benthic impacts of a net cage fish farm	<p>1 Nitrogen: Kjeldahl technique</p> <p>2 Dry matter: weight loss after 24 h at 105°C</p> <p>3 Ash: weight loss after 24 h at 550°C in a muffle furnace</p> <p>4 Protein: multiplying N by 6.25</p> <p>5 Total phosphorus: ashing the samples and using the vanado-molybdate method</p> <p>6 Total carbohydrate: calculated as the difference</p> <p>7 Gross energy: combustion in a</p>	<p>1 Removal of 4.2 g organic carbon, 0.70 g nitrogen and 7.5 mg phosphorus/kg mullet/m²/day from the organically enriched sediment</p> <p>2 Improvement of the quality of sediments below intensive net-cage fish farms</p>	Lupatsch <i>et al.</i> , 2003

22	Herring by-products from frozen herring	Fish oils extraction	Fatty acids composition, lipid class distribution, free fatty acids (FFA), peroxide value (PV), anisidine value (AV), fluorescence products (FP), α -tocopherol, lipid content, moisture, protein, salt, copper, iron	Minced herring by-products pumped to an insulated scraped-surface heat exchanger indirectly heated by steam and separated in a three phase decanter into a high solids phase, a water phase and lipid phase (oil)	<p>calorimeter using benzoic acid as the standard</p> <p>8 Organic carbon: C content of protein (520 g C, 23.6 MJ), lipid (766 g C, 35.0 MJ) and carbohydrate (400 g C, 17.50 MJ)</p> <p>1 Fatty acids composition: GC with a flame ionization detector (FID)</p> <p>2 Lipid class distribution: gravimetrically by solid phase extraction (SPE) (Kaluzny <i>et al.</i>, 1985)</p> <p>3 Free fatty acids (FFA): titration according to the AOCS Official Method Ca 5a-40</p> <p>4 Peroxide value (PV): AOCS Official Method Cd-8b-90</p> <p>5 Anisidine value (AV): AOCS Official Method Cd 18-90</p> <p>6 Fluorescence products (FP): excitation (ex) maximum at 367 nm and an emission (em) maximum at 420 nm were using FIA (Undeland <i>et al.</i>, 1998)</p> <p>7 α-Tocopherol: reversed phase HPLC</p> <p>8 Lipid content: gravimetrically after extraction</p> <p>9 Moisture: according to Karl-Fischer method</p>	<p>1 Oil: rich in polyunsaturated <i>n</i>-3 fatty acids (EPA and DHA)</p> <p>2 Herring oil: low copper content (<0.1 mg/kg oil), iron concentration (0.8 mg/kg oil)</p> <p>3 Maatjes herring fillets: 32% higher copper content than by-products, whereas by-products had 3 times higher iron content than fillets</p> <p>4 α-tocopherol and FFA concentrations: remained stable at different storage conditions (light at room temperature, dark at room temperature, dark at 50°C)</p> <p>5 In dark, in the absence of oxygen and at room temperatures: low oil oxidation</p>	Aidos <i>et al.</i> , 2001
----	---	----------------------	--	---	---	---	----------------------------

(Continued)

Table 14.3 (Continued)

No	Kind of waste	Treatment	Parameters	Methodology	Quality control methods	Results	References
					10 Protein: Kjeldahl digestion method		
					11 Salt: titration according to Volhard's method (Kolthoff and Sandell, 1952)		
					12 Copper: with a Perkin-Elmer 5100 graphite furnace atomic absorption spectrometer (AAS)		
					13 Iron: with a flame atomic absorption spectrometer		
23	Herring by-products (maatjes, frozen and fresh by-products)	Fish oils extraction	Free fatty acids (FFA), peroxide value (PV), anisidine value (AV), R-tocopherol, total lipid soluble fluorescent lipid oxidation products (FP), fatty acid composition, copper, iron	Minced herring by-products pumped to an insulated scraped-surface heat exchanger indirectly heated with steam and separated in a three phase decanter into a high solids phase, a water phase and lipid phase (oil)	1 Free fatty acids (FFA): titration according to the AOCS Official Method Ca 5a-40 2 Peroxide value (PV): AOCS Official Method Cd-8b-90 3 Anisidine value (AV): AOCS Official Method Cd 18-90 4 α -Tocopherol: slightly modified method (Lie <i>et al.</i> , 1994) 5 Total lipid soluble fluorescent lipid oxidation products (FP): excitation (ex) maximum at 367 nm and an emission (em) maximum at 420 nm 6 Fatty acid composition: AOCS Official method Ce 1b-89 7 Copper: with a Perkin-Elmer 5100 graphite	1 Crude oils: very low content of copper (<0.1 mg/kg oil) and iron values (0.03, 0.1, 0.8 mg/kg oil for maatjes, frozen and fresh by-products oil, respectively) 2 Maatjes oil: reduced amount of α -tocopherol 3 Maatjes and fresh oil: low presence of FFA that remained constant over storage 4 Frozen by-products oil: constant increase of FFA during storage 5 Secondary oxidation products were measured for fresh oil, while for the maatjes and frozen by-products oil, tertiary oxidation products were detected 6 Maatjes and frozen oils: intense odor, correlating	Aidos <i>et al.</i> , 2003

24	Cannery wastewaters	Heating and centrifugation	pH, TSS, VSS, chloride, fats, COD, protein content, nitrogen concentration, moisture, ashes, oil characterization (calorific value, freezing point, viscosity, elemental composition, ashes, density)	<p><i>Laboratory scale assay:</i> The sample was heated in a thermostated water bath at 70°C and then centrifuged at 25°C, 7.500 rpm and for 20 min</p> <p><i>Industrial scale assay:</i> The sample was heated using heat coils and centrifuged twice for solids removal from liquid phase and oil and water separation with residual solids removal</p>	<p>furnace atomic absorption spectrometer (AAS)</p> <p>8 Iron: with a graphite furnace atomic absorption spectrometer</p> <p>1 pH, TSS, VSS, chloride and fats: Standard Methods (APHA, 1985)</p> <p>2 COD: by a semi-micro method adapted to high salinity waters (Soto <i>et al.</i>, 1989)</p> <p>3 Protein content: by the Lowry method (Lowry <i>et al.</i>, 1951)</p> <p>4 Nitrogen concentration: Kjeldahl method</p> <p>5 Moisture and ashes: Standard Methods (APHA, 1985)</p> <p>6 Oil characterization: Calorific value: method ASTM D-0240/92 Freezing point: by differential scanning calorimetry Viscosity: using a rotational viscometer Elemental composition: by a CHNS analyzer Ashes: Standard Methods (APHA, 1985). Density: densimeter</p>	<p>positively at the end with sensory attributes of train-oil, acidic, marine and fishy</p> <p>1 Oil fraction: high percentage of carbon and hydrogen (89% by weight), absence of nitrogen, ash (0.28%) and sulfur contents (0.09%), high calorific value (HHV) slightly lower than fuel oil no. 1 that can be utilized as a biofuel</p> <p>2 Solid fraction (fine and thick solids): high organic matter content (ash concentration 3.5% by weight) and moisture (72.6% by weight), can be used as a fishmeal</p> <p>3 Water fraction: needs further treatment</p>	Garcia-Sanda <i>et al.</i> , 2003
25	Tuna-cooking liquid effluents	Evaporation	pH, TSS, VSS, chloride, fats, COD, protein content, nitrogen concentration, moisture, ashes, oil characterization	<p><i>Laboratory-scale evaporation:</i> The sample was fed in a rotary evaporator (250 ml, 60°C, 0.1 MPa)</p> <p><i>Pilot-scale evaporation:</i> The sample was fed in a rising film evaporator</p>	<p>1 pH, TSS, VSS, chloride and fats: Standard Methods (APHA, 1985)</p> <p>2 COD: by a semi-micro method adapted to high salinity waters (Soto <i>et al.</i>, 1989)</p>	<p>1 Condensate: low suspended solids (TSS 50 mg/l) and organic matter content (COD 200 mg/l), high pH value</p> <p>2 Concentrate: increase</p>	Garcia-Sanda <i>et al.</i> , 2003

(Continued)

Table 14.3 (Continued)

No	Kind of waste	Treatment	Parameters	Methodology	Quality control methods	Results	References
				(7.400 ml, 108°C, 0.5 MPa)	3 Protein content: by the Lowry method (Lowry <i>et al.</i> , 1951) 4 Nitrogen concentration: Kjeldahl method 5 Moisture and ashes: Standard Methods (APHA, 1985) 6 Oil characterization: Calorific value: method ASTM D-0240/92 Freezing point: by differential scanning calorimetry Viscosity: using a rotational viscometer Elemental composition: by a CHNS analyzer Ashes: Standard Methods (APHA, 1985) Density: densimeter	of solid, organic matter, protein (up to 10%), density, viscosity and decrease of pH 3 Use of concentrate as animal foodstuff (<25%) – good source of <i>n</i> -3 fatty acids	
26	Pink shrimp shell waste	Deproteinization and demineralization	Water, fat, ash, nitrogen, crude protein, calcium, chitin	Deproteinization of shrimp shell powder at 25–99°C, with 0.50–2.50 N NaOH, at ratio of NaOH to shrimp shell 5.0–20.0 for 5–360 min. Demineralization of shrimp shell powder at 30–100°C, with 0.20–2.00 N hydrochloric acid, at ratio of hydrochloric acid to solid 3.0–5.0 ml/g, for 5–60 min	1 Water, fat, and ash contents: Standard Methods (AOAC, 1984) 2 Nitrogen Kjeldahl method 3 Crude protein content: multiplying the corrected nitrogen content by 6.25 4 Calcium content: with a atomic absorption spectrometer 5 Chitin content: method of Hackman and Goldberg (1971)	1 Optimal deproteinization conditions: 75°C and 2.5 N NaOH 2 Optimal demineralization conditions: 1.7 N HCl, with an acid solution to solid ratio of 9 ml/g at ambient temperature 3 Isolation of chitin	Chaing and Tsai, 1997
27	Filleting waste from silver carp	Treatment with dairy proteins and microbial transglutaminase	Mechanical properties (textural profile analyses, punch	Microbial transglutaminase (3-g/kg), whey protein and sodium caseinate	Mechanical properties: Texturometer	1 Increase of mechanical properties when the salt level also increased 2 Increase of mechanical	Uresti <i>et al.</i> , 2001

			test and torsional test analyses and expressible water)	(10 g/kg), and NaCl (0, 10, 20 g/kg) were mixed with the paste. The mixture was sprayed with commercial regular vegetable oil and immersed in water at 40°C for 1 h, followed by immersion in water at 90°C for 20 min. Then placed in a water bath and cooled at 4–5°C for 30 min			properties of non-salted and low-salt products by using dairy proteins 3 Microbial transglutaminase increased expressible water
28	Fish canning wastewater	Coagulation-flocculation treatment	BOD, COD, total suspended solids, total dissolved solids, oil, grease, potassium, ammonia, phosphate, sulfate, sodium, total hardness, sulfide, nitrate, chloride, total protein	Five chemical coagulation/flocculation treatments were tested using FeCl ₃ (0.4 g Fe/l), Al ₂ (SO ₄) ₃ (1.2 g Al/l), Ca(OH) ₂ (0.5 g Ca/l), FeCl ₃ and Ca(OH) ₂ (0.4 g Fe/l + 0.2 g Ca/l), Al ₂ (SO ₄) ₃ and Ca(OH) ₂ (1.2 g Al/l + 0.3 g Ca/l)	1 BOD: membrane electrode method 2 COD: open reflux method 3 Total suspended solids: dried residue gravimetric method 4 Total dissolved solids: dried residue gravimetric method 5 Oil and grease: partition gravimetric method 6 Potassium: flame photometry 7 Ammonia: phenate colorimetric method 8 Phosphate: stannous chloride colorimetric method 9 Sulfate: barium chloride drying of residue gravimetric method 10 Sodium, total hardness, sulfide, nitrate and chloride: ion selective electrode method	1 80–88% BOD ₅ , 75–85% COD, 94–95% total suspended solids (TDS) and 31–53% total dissolved solids (TDS) decrease 2 In treatments 3, 4 and 5 total hardness increased by 61%, 319% and 419%, respectively 3 In treatments 1, 2, 3 and 4 ammonia content decreased up to 90%, 56%, 100%, and 100%, respectively 4 In treatments 2 and 3 phosphate decreased by 90% 5 73–89% oil and grease and 70–92% total protein decrease 6 Best method involved the use of FeCl ₃ and Ca(OH) ₂ (0.4 g Fe/l and 0.2 g Ca/l, respectively) (Treatment: 4) 7 Dried precipitate averaged 50 g/l contained 40% by weight recovered protein and 20% recovered fat	Fahim <i>et al.</i> , 2001

(Continued)

Table 14.3 (Continued)

No	Kind of waste	Treatment	Parameters	Methodology	Quality control methods	Results	References
					11 Total protein: Biuret reaction colorimetric method	8 Solid was ideal for on-site reprocessing as animal feed 9 Final effluent safe for controlled use in some irrigation applications or forestry projects at the desert area	
29	Fish farm waste	Integrated marine cultivation of <i>Gracilaria chilensis</i> (Gracilariales, Rhodophyta)	Carbon, total nitrogen, total phosphorus, agar content	The algae were placed 10 m (1st station) and 150 m west of the cages (2nd station) and at 1 km south of the fish farm (3rd station)	1 Carbon and total nitrogen: CHN elemental analyzer 2 Total phosphorus: extraction using hydrochloric acid (Aspila <i>et al.</i> , 1976) 3 Agar content: according to Cancino and Orellana (1987) and expressed as percentage of <i>Graciluria</i> dry weight	1 Station A: 40% higher growth rate of <i>Gracilaria</i> cultivated compared to stations B and C 2 Station A: higher algae nutrient content close to the cages (1.9–2.1 mmol N/g dw and 0.28–0.34 mmol P/g dw) compared to the other distances 3 Agar yield per unit biomass 17–23% of dry weight – lowest close to the farm 4 Highest accumulated agar production close to the fish cages 5 1 ha cultivation of the algae, close to the fish cages, resulted in 5% removal of dissolved inorganic nitrogen and 27% of released dissolved phosphorus	Troell <i>et al.</i> , 1997
30	Feed waste and sludge	Treatment through an intensive recirculating fish production system	Total solids (TS), volatile solids (VS), suspended solids (SS), TAN, NO ₂ ⁻ , NO ₂ -N + NO ₃ -N, TS, VS, total Kjeldahl nitrogen	The system included particle traps at the bottom of a tank to remove feed waste and excrement, sludge collectors where the removed particles	<i>Solid waste:</i> 1 Total solids (TS), volatile solids (VS) and suspended solids (SS): Standard Methods (APHA, 1989) analyses	1 Total ammonia nitrogen (TAN) removal by the biofilter up to 65% (on a single pass through the filter) 2 80% and 41% suspended solids removal by the	Twarowska <i>et al.</i> , 1997

(TKN), total phosphorus (TP), COD, sodium (Na), potassium (K), magnesium (Mg), calcium (Ca), zinc (Zn), copper (Cu), pH, dissolved oxygen, free carbon dioxide, alkalinity

settled, a rotating screen filter for suspended solids removal, a high-rate linear-path trickling biological filter for nitrification and two downflow columns for oxygen injection

- 2 TAN: salicylate method
- 3 Nitrite nitrogen (NO₂-N): cadmium reduction method
- 4 Nitrite-nitrogen plus nitrate-nitrogen (NO₂-N + NO₃-N): copper-cadmium reduction method (EPA, 1979)

Sludge:

- 1 TAN, NO₂-N, NO₂⁻-N+NO₃-N, TS and VS: gravimetric methods (APHA, 1989)
- 2 Total Kjeldahl nitrogen (TKN): persulfate digestion and ammonia-salicylate method for automated analysis (EPA, 1979)
- 3 Total phosphorus (TP): ascorbic acid method for automated analysis (EPA, 1979)
- 4 COD: potassium dichromate-sulfuric acid digestion and calorimetric automated analysis (EPA, 1979)
- 5 Sodium (Na), potassium (K), magnesium (Mg), calcium (Ca), zinc (Zn) and copper (Cu): nitric acid digestion and atomic absorption or emission spectroscopy (APHA, 1989)
- 6 pH: pH meter

- 3 18% feed volatile solids input removal by the sludge collectors and the screen filter

(Continued)

Table 14.3 (Continued)

No	Kind of waste	Treatment	Parameters	Methodology	Quality control methods	Results	References
31	Rainbow trout raceway effluent	Baffled sedimentation with and without the installation of artificial substrates	Temperature, pH, total suspended solids, (TSS), total organic carbon, (TOC), total ammonia nitrogen, (TAN), nitrite (NO ₂ -N), nitrate (NO ₃ -N), orthophosphate, OP (PO ₄ -P), total phosphorus TP (PO ₄ -P), dissolved oxygen (DO)	The trout effluent entered the basin consisting of two consecutive sections (first and second) and, within the first section, four linear segments of biofiltration media were installed. Treatment efficiency was determined under normal and cleaning/harvesting operations	<p>7 Dissolved oxygen: polarographic probe and meter</p> <p>8 Free carbon dioxide: titrimetric methods with a calorimetric end point (APHA, 1989)</p> <p>9 Alkalinity: titrimetric methods with a calorimetric end point (APHA, 1989)</p> <p>1 Temperature: dissolved oxygen/temperature meter</p> <p>2 pH: w/electrosylicate pH probe</p> <p>3 Total suspended solids (TSS): Standard Methods (APHA, 1998)</p> <p>4 Total organic carbon, (TOC): Persulfate-ultraviolet oxidation Method, TOC analyzer</p> <p>5 Total ammonia nitrogen (TAN): Salicylate method</p> <p>6 Nitrite (NO₂-N): Dianosation method</p> <p>7 Nitrate (NO₃-N): Cadmium reduction method</p> <p>8 Orthophosphate OP (PO₄-P): Ascorbic acid method</p>	<p>1 71–79% TSS removal during normal and 79–92% cleaning and harvesting conditions</p> <p>2 Majority of TSS removal in the first section of the basin (84% and 94% TSS removal for normal and cleaning/harvesting conditions, respectively)</p> <p>3 Dissolved nutrients (TAN, nitrate, and nitrite) removal, with the exception of OP</p> <p>4 Shorter retention times for the first section and the overall basin (32–37% and 17–27%, respectively) than the theoretical values</p> <p>5 Hydraulic efficiency increased with increasing L:W (length:width) ratios</p>	Stewart <i>et al.</i> , 2006

32	Fish 'sawdust'	Alkaline extraction	Nitrogen, protein, moisture, fat, ash, amino acids	Fish 'sawdust' (hake and monkfish) was added to an aqueous solution containing HCl or alkali (NaOH or Ca(OH) ₂). Two protein extracts were obtained: the first treated with NaOH, and the second with Ca(OH) ₂ . The first extract was precipitated with HCl and the second with H ₃ PO ₄ . The supernatant protein solutions were treated with Na ₆ (PO ₃) ₆	<p>9 Total phosphorus TP (PO₄-P): Acid persulfate digestion, ascorbic acid detection method</p> <p>10 Dissolved oxygen (DO): dissolved oxygen/temperature meter</p>	<p>1 Nitrogen: Kjeldahl method.</p> <p>2 Protein: Kjeldahl method</p> <p>3 Moisture, fat, ash: AOAC methods</p> <p>4 Amino acids: amino acid autoanalyzer after hydrolysis of proteins in 6 M HCl for 24 h at 110°C</p>	<p>1 Protein recovery</p> <p>2 Protein solubility: lower at pH 5.0–6.0 for hake waste and at pH 5.0 for monkfish waste</p> <p>3 Protein recovery: higher at pH 2.0–4.0</p> <p>4 Increase in ratio of extracting media to raw material caused increase of extraction yields of both species</p> <p>5 The amount of extracted protein increased with an increase in temperature</p> <p>6 Protein extraction at pH 2, 4 and 11 increased with increasing NaCl concentration</p> <p>7 Protein solubility increased when the ionic strength increased at neutral pH</p> <p>8 Soluble proteins recovery generated from NaOH-HCl and Ca(OH)₂-H₃PO₄ at different concentrations of Na₆(PO₃)₆ were similar</p>	Batista, 1999
----	----------------	---------------------	--	--	--	---	---	---------------

Table 14.4 Advantages and disadvantages of fish waste treatment methodologies

Treatment	Advantages	Disadvantages	References
<i>Hydrolysis</i>	<ol style="list-style-type: none"> 1 Improves digestion process by reducing HRT or increasing digestion 2 Increases gas production by increasing digestion 3 Low cost solution to digester upgrade 	<ol style="list-style-type: none"> 1 High operation cost 2 Not necessarily a benefit to well operated plants 3 Requires pilot work to determine benefits 	http://www.dayton-knight.com/publications/staff%20papers/Emerging_Processes_in_Biosolids_Treatment_2003.pdf
<i>Bioremediation</i>	<ol style="list-style-type: none"> 1 Natural process – acceptable by the public 2 Hazardous compounds degradation 3 Less expensive than other techniques 4 In situ/ex situ 	<ol style="list-style-type: none"> 1 Not rapid 2 Contaminants degradation under favorable conditions 3 Application only for biodegradable compounds 4 Constant monitoring for effectiveness assurance 	http://www.iupac.org/publications/pac/2001/pdf/7307x1163.pdf#search=%22bioremediation%20advantages%22; http://www.yorku.ca/bunchmj/ICEH/proceedings/Sasikumar_CS_ICEH_papers_465to469.pdf#search=%22bioremediation%20%20disadvantages%22; http://library.thinkquest.org/03oct/01840/New%20Page_5.htm
<i>Anaerobic treatment</i>	<ol style="list-style-type: none"> 1 Low energy consumption 2 Biogas production 3 Less waste sludge generation 4 Low investment costs 	<ol style="list-style-type: none"> 1 Odor problems 2 High maintenance and power costs 3 It is a pretreatment method; thus requiring a post-treatment method for waste disinfection 	http://www.lenntech.com/Pre-fermer.htm; http://www.achema.de/data/achema_/congress/1713.pdf#search=%22anaerobic%20treatment%20advantages%22; http://www.nps.gov/dsc/dsgncnstr/gpsd/ch9.html; http://greenbusinesscentre.com/images/Photos/Hig48.pdf#search=%22anaerobic%20treatment%20advantages%22
<i>Filtration</i>	<ol style="list-style-type: none"> 1 Small particles removal (1–60 μm) 2 Low cost method at low volume flows 3 No chemical and power requirements 4 Simple installation, operation, maintenance 	<ol style="list-style-type: none"> 1 Expensive at high volume flows 2 Clogging of filters 3 A pretreatment step may be required 4 Applied as a single method for wastewaters with low levels 	http://www.wvu.edu/~agexten/aquaculture/waste02.pdf#search=%22Best%20management%20practices%20to%20reduce%20aquaculture%20waste%22; http://www.unep.or.jp/letc/Publications/spc/Solid_Waste_Management/Vol_1/15-

<i>Screening</i>	<ol style="list-style-type: none"> 1 Simple operation 2 Low cost 3 Easy installation 4 Large solids (0.7 mm or larger) removal 	<p>of contamination</p> <ol style="list-style-type: none"> 1 Clogging of screen 	<p>Chapter9.pdf#search=%22food%20waste%20hydrolysis%20advantages%22; http://www.oas.org/dsd/publications/Unit/oea59e/ch24.htm http://www.fao.org/DOCREP/003/V9922E/V9922E05.htm; http://www.copa.co.uk/products_detail.asp?wastewaterId=837; http://www.unep.or.jp/letc/Publications/spc/Solid_Waste_Management/Vol_1/15-Chapter9.pdf#search=%22food%20waste%20hydrolysis%20advantages%22</p>
<i>Evaporation</i>	<ol style="list-style-type: none"> 1 Established and proven technology 2 Simple to operate 3 Widely applicable 	<ol style="list-style-type: none"> 1 High energy requirements 2 Multistage counter current rinsing essential 3 Returns impurities to bath 4 Additional treatment might be needed to control impurities 	<p>http://www.wmrc.uiuc.edu/main_sections/info_services/library_docs/manuals/finishing/rinsing.htm</p>
<i>Coagulation/flocculation</i>	<ol style="list-style-type: none"> 1 Removal of very fine particles 2 Increase in agronomic value of the sludge 3 Low maintenance 4 Reagent consumption optimized 5 Possibility of running in batch mode 	<ol style="list-style-type: none"> 1 Expensive process 2 Process may generate toxic sludge 3 Additional management of larger amounts of removed sludge 4 Reagent addition must be carefully controlled to preclude unacceptable concentrations in treatment effluent 5 As discharge standards become more stringent, further treatment may be required 	<p>http://www.cals.ncsu.edu/waste_mgt/natcenter/modules/powerpoint5.pdf; http://www.bono.it/prodotti/prodotto.asp?prodpassata=cppprod&unit=ba&cmp=ba; http://www.frtr.gov/matrix2/section4/4-50.html</p>

Adapted from Fahim *et al.*, 2001

products (Perea *et al.*, 1993; Kristinsson and Rasco, 2000a; Larsen *et al.*, 2000; Guerard *et al.*, 2001; Coello *et al.*, 2002; Laufenberg *et al.*, 2003). Probably more than 50% of the remaining material from the total fish capture is not used as food and involves almost 32 million tons of waste (Kristinsson and Rasco, 2000a).

Animal feed

Nowadays, the use of food wastes as animal feed is an alternative of high interest because it is of environmental and public benefit as well as reducing the cost of animal production (Samuels *et al.*, 1991; Westendorf *et al.*, 1998; Myer *et al.*, 1999; Westendorf, 2000). Offal from the fishing industry could be used as a feed ingredient as it represents a valuable source of high quality protein and energy (New, 1996; Gabrielsen and Austreng, 1998).

Kotzamanis *et al.* (2001) studied the potential utilization of trout offal as an ingredient of gilthead bream *Sparus aurata* (L.) diets. Trout offal (heads, skeletons, tails and intestines) was minced, homogenized and mixed thoroughly with other dietary ingredients for pellet preparation of experimental diets (diet A (control): 410 g/kg fishmeal and 58 g/kg fish oil; diet B: fishmeal 338 g/kg and trout heads, skeletons and tails; diet C: similar to diet A, but fish oil was substituted by trout intestines). The microbiological load of the trout offal was low (10^4 cfu/g); while the fatty acids (FA) composition indicates that is a good lipid source, because of total n-3 highly unsaturated fatty acids (HUFA) and arachidonic acid 20:4n-6 (AA) levels. However, the high level of 18:2n-6 fatty acid of trout intestine, which is not a natural constituent of sea bream lipids, is the main drawback. Differences in liver glycogen content were more pronounced than differences in dietary carbohydrate. Increased hematocrit values with diets (such as B) prompting faster growth have been reported (Barnhart, 1969). Trout offal is an alternative, non-polluting way of using the by-products of fish industry in sea bream diets.

Fish waste (mainly heads, bones, skin, viscera and sometimes whole fish and parsley) was heated at 65, 80, 105 and 150°C for 12 h to reduce the moisture content to 10–2%, which is the recommended moisture content in animal feed (NRC, 1998). Fish waste proved to be a great source of minerals, protein (58% dry matter –M) and fat (19% DM). Fatty acids (monounsaturated acids, palmitic and oleic acids) are abundant in fish waste, while the high ash content (22% DM) indicates a high percentage of minerals in fishmeal. Toxic substances (such as As, Pb, Hg and Cd) were detected in fish waste at rather low concentrations. Waste digestibility decreased with temperature and hence temperatures over 105°C should not be used toward reducing the moisture and ensuring the microbiology quality. Fish waste can be used as alternative feedstuffs in swine diets to meet partially the protein requirements and serve as a substitute for common sources of protein (i.e. soybean meal and commercial fishmeal) (Esteban *et al.*, 2007).

Fish wastes of the species *Sardina pilchardus* were chopped, mixed with 15% molasses, inoculated with 5% starter culture of *Lactobacillus plantarum*, incubated at $22 \pm 2^\circ\text{C}$ for 20 days and then stored for 20 days. The obtained product, incorporated with bran and ground barley to make different formulae, was compared with commercial control feed and then fed to broilers. The results indicated a net increase in the

weights of broilers fed on fish silage supplemented with barley flour and bran, with slight differences compared with each other and with the control. Moreover, pH decreased considerably (initial value 6.13–6.75) in the fermenting product and then remained constant at 4.2 and 4.5, nitrogen decreased slightly (5.3–5.7%), while non-protein nitrogen increased considerably (220–262%). Fish waste can be used as a nitrogen source and possibly as a probiotic ingredient for poultry feeding (Hammoumi *et al.*, 1998).

Coward-Kelly *et al.* (2006) treated shrimp head waste (*Penaeus indicus*) with lime at different temperatures (75, 100, 125°C) and lime/shrimp ratios (0, 0.05, 0.1, 0.2 g Ca(OH)₂/g dry shrimp) in order to determine the repeatability, and the effect of temperature and lime loading on solubilizing protein in shrimp head waste. Shrimp heads were hydrolyzed in less than 15 min and do not require strong treatment conditions (low temperature, low lime loading and short times). Shrimp head waste contained 20% ash, 10.3% total Kjeldahl nitrogen (TKN) corresponding to 64% crude protein and chitin, 18% lipids and other compounds, whereas little amino acid degradation occurred. The protein-rich material can be used as a monogastric animal feed supplement and the residual solid-rich in calcium carbonate and chitin material can be used to generate chitin and chitosan. The latter can find many applications on its own or as blends either as a dietetic product or as edible films for food preservation purposes (Arvanitoyannis *et al.*, 1997, 1998).

Biodiesel/biogas

Biodiesel fuel, acquired from oils and fats of vegetables and animals, is a substitute for, or an additive to, diesel fuel derived from petroleum (Alcantara *et al.*, 2000). However, during the early 1980s, engine tests showed that the combustion of vegetable oils caused durability problems related to incomplete combustion such as nozzle coking, engine deposits, ring sticking and crankcase lubricant contamination (Dunn and Bagby, 2000). Furthermore, the higher viscosity of vegetable oils compared to diesel fuel caused excessive carbon deposition and thickening of lubricating oil and was largely responsible for the problems encountered in using vegetable oils as a diesel fuel, especially in relatively cold areas and during cold seasons (Clark *et al.*, 1983).

Kato *et al.* (2004) evaluated the ozone treated fish waste oil as a transportation diesel fuel. Fish oil, a fish powder by-product, was pretreated by filtration, placed in a reactor with two catalysts (iron oxide and calcium phosphate monobasic) and mixed with bubbling ozone (5 g/h, 16 g/m³ (about 8000 ppm)) for 1 h at room temperature (primary ozone treatment). Then the sample was filtered again and treated with ozone at the same conditions for 30 min, but in the absence of catalysts (secondary ozone treatment) (Figure 14.11). The oil manufactured from fish waste was tested for its density, flash point, pour point, heating value, distillation test and sulfur content. The yield of the produced fuel was 95–96%, after filtration and primary and secondary treatments. The obtained oil was found to have suitable properties for use in diesel engines, such as almost identical higher heating value (HHV) (10 700 kcal/kg) and density (at 15°C, 0.87 g/cm³), lower flash and pour points (37°C and –16°C, respectively) compared to

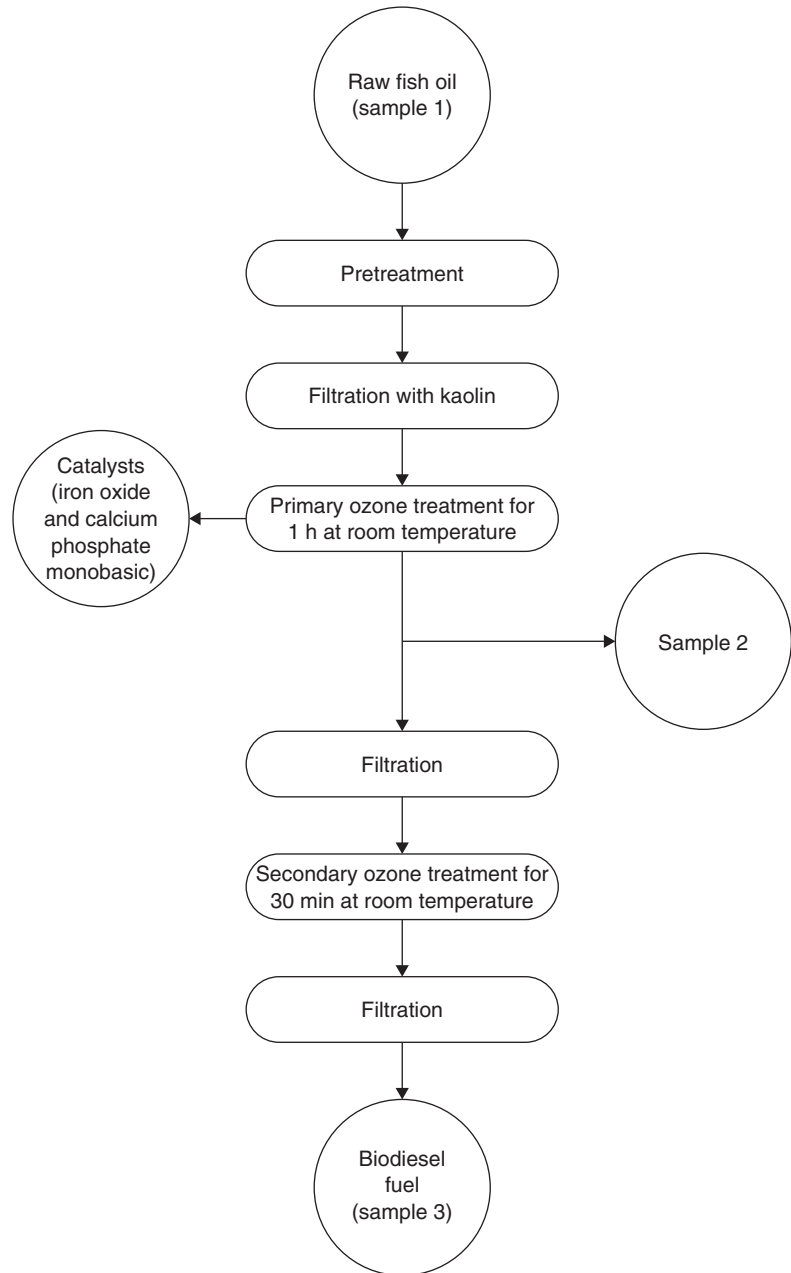

Figure 14.11 Ozone treatment of oils (adapted from Kato *et al.*, 2004)

commercial diesel fuel, no production of sulfur oxides, lowered or no soot, polyaromatic and carbon dioxide emissions. These properties suggested that the obtained oil had better properties than methyl esterified vegetable oil waste and was suitable for diesel engines, especially at low temperature areas (Table 14.5).

Table 14.5 Fuel quality produced from different raw materials

Parameters	Ozone treated fish waste oil	Methyl etherified vegetable oil	Diesel derived from petroleum
Density (15°C) (g/cm ³)	0.87	0.88	0.84
Flash point (°C)	38	103.1	66
Pour point (°C)	-16	60	-8
HHV (kcal/kg)	10 700	9490	10 920

Adapted from Kato *et al.*, 2004

Lanari and Franci (1998) examined the potential of biogas production by fish-farm effluents in a small-scale closed system with partially recirculated water. The system consisted of two fish tanks with a recirculation rate of 60% and a rainbow trout daily feeding allowance 1, 1.5 and 2% of live weight, an up-flow anaerobic digester connected with a sedimentation column and equipped with an aerobic filter run at psychrophilic conditions (24–25°C) and with hydraulic retention time 22–38 days, a zeolite column for final treatment of effluents, a gas flow meter and a methane analyzer. Biogas and methane production amounted to 49.8–144.2 l/day and 39.8–115.4 l/day, respectively. The highest biogas and methane production was reported at the highest feeding allowance, while the biogas methane content at 2% feeding allowance was higher than 80%. A remarkable reduction in volatile solids (VS) (92–97%), suspended solids (SS) (96–99%) and total ammonia nitrogen (TAN) content (59–70%) in the anaerobic digester was reported, while the zeolite ion-exchange column improved water quality of effluent produced by the digester, as the chemical oxygen demand (COD) was reduced up to 45%. The produced biogas can be used directly in a burner to produce thermal energy or, following depuration, can be employed as fuel in a co-generation plant to produce thermal and electrical or mechanical energy (Table 14.6).

The anaerobic treatment of sludge from a salmon smolt hatchery in a continuous stirred tank reactor (CSTR) at mesophilic temperature (35°C) and 55–60 days hydraulic retention time (HRT) was investigated by Gebauer and Eikebrokk (2006). The main components of treated sludge with 1.5–3.3% total (dry) solids (TS) were: 32% nitrogen, 8.5% phosphorus, low potassium content, acceptable concentration of heavy metal apart from zinc and high levels of volatile fatty acids (VFA) that may cause phytotoxicity. The treated sludge is in liquid form and can be used as a liquid fertilizer on cultivated land and meadows, however, requirements for special means of application are needed. Furthermore, the methane content in biogas stabilized at 59.4–60.5% vol., methane yield was 0.14–0.15 l/g COD, nitrogen mineralization increased to 70%, and 44.8–53.5% COD removed. The potential of the sludge for energy production was also exploited. The net energy production from the biogas was 43–47 MW h/year and could cover 2–4% of the energy demand in flow-through hatcheries and at least twice as much in recirculation hatcheries.

Natural pigments

Carotenoids are responsible for the color of many important fish and shellfish products. Most expensive seafoods, such as shrimp, lobster, crab, crayfish, trout, salmon,

Table 14.6 Effect of trout daily feeding allowance (1, 1.5 and 2% of live weight) on operational data and biogas production from up-flow anaerobic digester and ion-exchange column filled with zeolites

Parameters	Feeding allowance		
	1%	1.5%	2%
<i>Up-flow anaerobic digester</i>			
Biogas production (l/day)	49.8	78.8	144.2
CH ₄ content in biogas (%)	>80	>80	>80
CH ₄ production (l/day)	39.84	63.04	115.36
pH reduction (units)	–	0.1	0.1
Total nitrogen increase (%)	157.4	26.1	23.4
TAN increase (%)	1751.4	1093.5	1533.1
Total solids decrease (%)	92	92.7	91.2
Soluble solids decrease (%)	45.5	42.6	44.7
Suspended solids decrease (%)	99.5	98.6	96.4
Volatile solids decrease (%)	97.4	96.1	93.7
<i>Ion-exchange column filled with zeolites</i>			
pH increase (units)	0.5	0.5	0.7
Total nitrogen decrease (%)	87.3	89.6	89.7
TAN decrease (%)	99.4	97.7	97.3
COD reduction (%)	15	35.5	44.6

Adapted from D'Aqaro, E. and Lanari, D. *et al.*, 2003

redfish, red snapper and tuna, have orange-red integument and/or flesh containing carotenoid pigments (Haard, 1992). The grading or pricing of shrimp, salmon, rockfish and snapper is directly related to the intensity of red hue (Sacton, 1986).

Shrimp waste, such as head and body carapace, was used for carotenoids extraction with various organic solvents (methanol, ethyl methyl ketone, isopropyl alcohol (IPA), ethyl acetate, ethanol, petroleum ether, hexane) and solvent mixtures (acetone and hexane, IPA and hexane) at various extraction conditions (percentage of hexane in the solvent mixture of IPA and hexane, ratio of solvent to waste and number of extractions) (Sachindra *et al.*, 2006). The results showed that the highest carotenoids yield (43.9 µg/g waste) was recorded when the carotenoids were extracted with a mixture of IPA and hexane, followed by IPA (40.8 µg/g) and acetone (40.6 µg/g), whereas the lowest carotenoid yield was obtained with petroleum ether (12.1 µg/g) and hexane (13.1 µg/g). The optimized conditions for extraction of carotenoids from shrimp waste were: 60% hexane in the solvent mixture of IPA and hexane, a solvent-to-waste ratio of 5 in each extraction and three extractions. The recovered carotenoids can be effectively used instead of synthetic carotenoids in aquaculture feed formulations and the residue available after extraction may be used for the preparation of chitin/chitosan (Sachindra *et al.*, 2006).

Samples of fertilized eggs, week-old fry of *Cyprinus carpio* L. and the fish of that species, aged one month, one year and two years were used for carotenoid pigment recovery by Czczuga (1979). Carotenoids were extracted by 95% acetone in a dark room. Saponification was carried out by 10% KOH in ethanol at a temperature of about 20°C for 24 hours in the dark under a nitrogen atmosphere. The obtained

carotenoids were astaxanthin, μ -, γ -, η -carotene, tunaxanthin, isozeaxanthin, phoenicoxanthin and canthaxanthin.

Food industry/cosmetics

The recovery of chemical components from seafood waste materials, which can be used in other segments of the food industry, is a promising area of research and development for the utilization of seafood by-products. Researchers have shown that a number of useful compounds can be isolated from seafood waste including enzymes, gelatin and proteins that have antimicrobial and antitumor capabilities. Chitosan, produced from shrimp and crab shell, was shown to have a wide range of applications from the cosmetic to pharmaceutical industries (http://ift.confex.com/ift/2001/tech-program/paper_6188.htm).

Aoki *et al.* (2004) partially purified proteases from Northern shrimp *Pandalus borealis*, for beef tenderization. Shrimp head protein was extracted, purified partially, dissolved in PBS (pH 7.4) and diluted to final concentration 10 μ m/l, before being added to raw beefsteaks. The mixture was incubated for 1 h at 10°C, cooked at 70°C, cooled and stored at 4°C for 24 h. Shrimp proteases can be used on an industrial scale in the food industry as they proved to be effective for beef meat tenderization, inactive after mild heat treatment and active at low temperatures, thus resulting in energy savings through operation at room temperature.

Khan and coworkers (2003) prepared fish protein hydrolysate (FPH) from fish scraps of five marine species (white croaker *Agryrosomus argentatus*, horse mackerel *Tachurus japonicus*, flying fish *Cypselurus heterurus*, chub mackerel *Scomber japonicus* and sardine *Sardinops melanostictus*). Fish scraps (head, viscera, scale, skin, caudal fin and bone) were treated according to the method suggested by Iwamoto *et al.* (1991) with the following modifications: pH adjustment to 8.0 by 1 N NaOH, pH adjustment to 6.0 using DL-malic acid and pH adjustment to 7.0 by 1 N NaOH prior to ultrafiltration. The obtained FPH had the following properties: 82.3–85.8% peptides, 0.2–0.3% lipid, 7.7–9.4% ash, 3.3–4.2% sugar, sodium chloride at traces and amino acids (Glx, Arg, Lys, Ser, Ala, and Leu). Lizard fish surimi was minced and mixed with 5% FPH, while the moisture content was adjusted to 82.0%. Then, the samples were stored at –25°C for 180 days. FPH can be utilized as a cryoprotectant for the suppression of denaturation of muscle protein of lizard fish meat during frozen storage because it suppressed the decrease of unfrozen water, maintained a high-gel forming ability and Ca-ATPase activity.

The extraction of milk-clotting enzymes from fish stomach mucosa for cheese manufacture would provide an inexpensive alternative to rennet substitutes for domestic use or to export to cheese-producing nations and would become a new food-related industry. Tuna fish gastric proteases were isolated using 25% NaCl solution (w/v) at different holding times (0–3 h), prior to the enzyme activation at pH 5.0. The temperature effect on tuna fish proteases yield was investigated both at 4°C and room temperature. It was found that protease yield was higher at 4°C than at room temperature for all holding times (0–3 h). Furthermore, tuna gastric enzyme had similar

activity to standard rennet at pH 4.0–6.0, it was less sensitive to losses of activity than rennet at pH > 6.4, unstable at pH > 7.0 and lost its activity at pH > 8.0. The milk-coagulating time of tuna proteases was similar to standard rennet at incubation temperature 32°C and pH 5.5–6.4 (Tavares *et al.*, 1997). However, further studies are required for testing tuna protease as rennet substitute on an industrial scale.

The effect of protein hydrolysate from Antarctic krill (*Euphausia superba*) meat compared to Kuruma prawns (*Penaeus japonicus*) and Tora velvet shrimps (*Metapenaeopsis acclivis*) on the state of water and denaturation by dehydration of lizard fish (*Saurida wanieso*) myofibrils was examined by Zhang *et al.* (2002). Hydrolysate production from krill was obtained by hydrolysis using 0.1% (wet weight) endotype protease after pH adjustment to 8.0 by sodium bicarbonate, derived from *Bacillus subtilis*, at 60°C for 2 h. The temperature increased to 90°C for 30 min and the enzymatic activity was terminated. The pH was adjusted to 6.0 by malic acid and the sample was further hydrolyzed by 0.1% (wet weight) exotype protease, derived from *Aspergillus oryzae*, and ultrafiltered (Iwamoto *et al.*, 1991). The lizard fish myofibrils were treated according to Katoh *et al.* (1977) with some modifications. The myofibrils were washed with 0.1 M KCl–20 nM Tris-maleate buffer, homogenized, filtered, lipid and salts were removed and mixed with hydrolysates, glucose and sodium glutamate (5% dry weight/100 g pelleted myofibrils as wet weight). The mixture was dehydrated at 5°C and, when the moisture content reached 10%, further dehydration was conducted. The hydrolysate main components were crude protein, crude ash, sugar content, sodium chloride at traces and amino acids (Glx, Asx, Arg, Lys, Gly, Ala, and Leu) (Table 14.7). The Antarctic krill hydrolysates had a similar effect to shrimp protein hydrolysates, stabilizing the bonding of water molecules and thus leading to suppressed denaturation of myofibrils during dehydration. Hydrolysates can be utilized as suppressive additives against myofibrillar protein denaturation and as a reagent to maintain moisture in food.

Fish skin, bone and fin (Skipjack tuna *Katsuwonus pelamis*, Japanese sea-bass *Lateolabrax japonicus*, ayu *Plecoglossus altivelis*, yellow sea bream *Dentex tumifrons*, chub mackerel *Scomber japonicus*, bullhead shark *Heterodontus japonicus* and horse mackerel *Trachurus japonicus*) were examined for potential isolation of collagen. It was found that collagen recovery ranged from 36 to 54%, with the highest value recorded from ayu *Plecoglossus altivelis* bone and the lowest from Japanese sea-bass *Lateolabrax japonicus* fin. The denaturation temperatures were: skin collagen 25.0 ± 26.5°C, bone collagen 29.5 ± 30.0°C and fin collagen 28.0 ± 29.1°C, lower than porcine collagen. Collagen from fish waste can be utilized on an industrial level only for supplementing the skin of land vertebrates and as alternatives to mammalian collagen in foods, cosmetics and biomedical materials (Nagai and Suzuki, 2000).

Squid protein hydrolysate (SPH) was extracted from four squid species (Japanese flying squid *Todarodes pacificus*, bigfin reef squid *Sepioteuthis lessonania*, swordtip squid *Loligo edulis* and golden cuttlefish *Sepia esculenta*) with hydrolysis using endotype protease, derived from *Bacillus subtilis*, at 60°C for 2 h. The enzymatic activity was terminated with increasing the temperature to 90°C for 30 min. After pH adjustment to 6.0, the sample was hydrolyzed with exotype protease, derived from *Aspergillus oryzae*, and ultrafiltered. The SPH composition was 84–88% protein, 6–7% ash, 3% sugar, 61–64% hydrophilic amino acids, crude lipids, and NaCl trace components

Table 14.7 Chemical composition of protein hydrolysates (g/100 g dried matter) from different fish species

Fish species	Chemical composition			
	Crude protein (%)	Crude ash (%)	Sugar content (%)	Crude lipid (%)
Antarctic krill (<i>Euphausia superba</i>)	86.2	5.8	8.2	0.03
Kuruma prawns (<i>Penaeus japonicus</i>)	93.7	2.3	4.7	0.06
Tora velvet shrimps (<i>Metapenaeopsis acclivis</i>)	85.9	5.8	9.3	0.05
Swordtip squid (<i>Loligo edulis</i>)	87.7	7.0	3.3	0.07
Japanese flying squid (<i>Todarodes pacificus</i>)	87.7	6.1	3.4	0.26
Bigfin reef squid (<i>Sepioteuthis lessonania</i>)	87.9	6.1	3.4	0.21
Golden cuttlefish (<i>Sepia esculenta</i>)	84.3	6.9	3.6	0.12
Northern pink shrimp (<i>Pandalus eous</i>)	89.8	4.7	4.6	0.02
Endeavour shrimp (<i>Metapenaeus endeavouri</i>)	91.5	5.2	3.0	0.01
Black tiger shrimp (<i>Penaeus monodon</i>)	91.0	5.1	3.6	0.01
	Non-protein nitrogenous compound (%)	Ash (%)	Sugar content (%)	Lipid (%)
White croker (<i>Agryrosomus argentatus</i>)	85.1	7.7	3.2	0.26
Horse mackerel (<i>Tachurus japonicus</i>)	85.8	8.7	3.0	0.23
Flying fish (<i>Cypselurus heterurus</i>)	82.3	9.2	3.6	0.18
Chub mackerel (<i>Scomber japonicus</i>)	82.7	9.4	3.1	0.17
Sardine (<i>Sardinops melanostictus</i>)	83.1	8.7	4.2	0.17

Zhang *et al.*, 2002; Hossain *et al.*, 2003; Khan *et al.*, 2003; Ruttanapornvareesakul *et al.*, 2005

(see Table 14.7). The development of a functional food from squid is a new perspective regarding the potential use of low cost squid meat in food processing and preservation (Hossain *et al.*, 2003).

Montero and Borderias (1990) examined the gel strength manufactured using collagen extracted from the muscle and skin connective tissue of hake (*Merluceius merluccius* L.) and trout (*Salmo irideus* Gibb) at various pH and NaCl concentrations. Fish waste collagenous material was stirred, filtrated, stored at 3–5°C for 24 h, diluted with solvent (1:6, w/v) at various NaCl concentrations (0, 1.0%, 1.5%, 2.0%, 3.0% and 6.0%). The pH levels studied in the absence of NaCl were 1–7 (adjustment with NaOH or HCl). The results revealed that trout skin had the highest collagen concentration at various pH and NaCl conditions, whereas hake muscle had the lowest collagen concentration (Figure 14.12). Furthermore, NaCl did not affect the gel-forming capacity of muscle collagenous material, even though a diminution of skin collagenous material was reported. The gel strength was greater at pH values close to 7 than in acidic media. The collagen-rich product can be used as functional material in the food industry, where gelification is a major application.

Morimura *et al.* (2002) treated fish bone from yellowtail fish for collagen isolation. The pretreated fish waste (80% fat and 90% inorganic compounds removal from bone) was placed in a reactor with enzyme L and agitated at 200 rpm for 60 min at 60°C and pH 8.0. The mixture was then centrifuged at 8000×g for 10 min and the precipitate weight was determined after drying at 105°C for 24 h. The results indicated

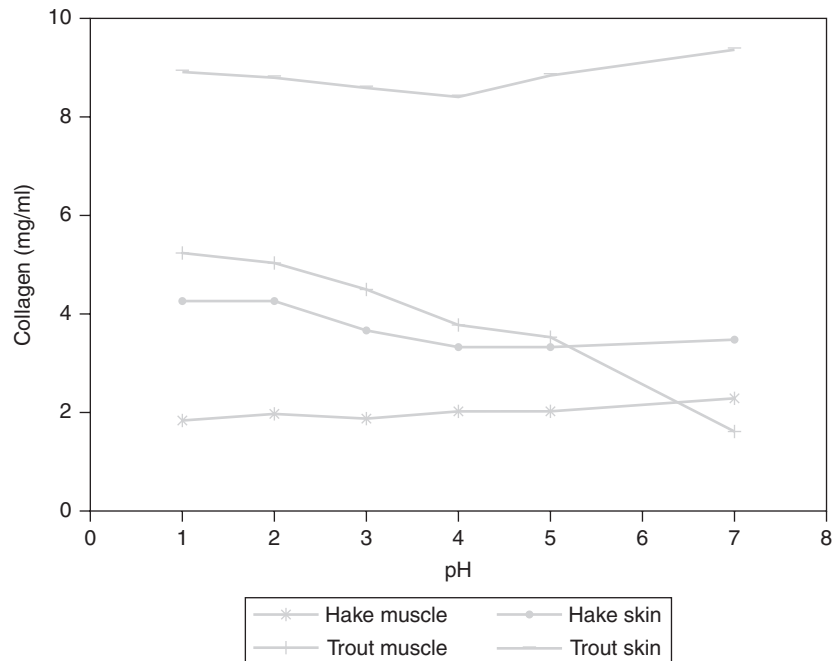

Figure 14.12 Concentration of various solutions of collagenous material from hake and trout muscle and skin at different pH (adapted from Montero and Borderias, 1990)

protein recovery up to 53%, high collagen degradation efficiency by enzyme L (85.5%) in comparison to enzyme K (69.2%) and other enzymes; both enzymes L and K originated from *Bacillus* species. Fat and inorganic materials from the pretreatment step can be utilized for production of cooking oil and calcium apatite, respectively. The hydrolysate, a composite of oligopeptides, can be used as a food additive due to its anti-radical (antioxidant) activity and for blood pressure reduction. Finally, the solid material from enzymic hydrolysis can be used as fertilizer (Figure 14.13).

Fillets from pacific whiting *Merluccius productus* were subjected to acid-aided (pH 2 and 3, by 2 N HCl) or alkali-aided (pH 10.5, 11 and 12, by 2 N NaOH) processing methods at temperatures below 5°C for fish protein recovery. Fish proteins were then mixed with cryoprotectants (5% sucrose, 4% sorbitol and 0.3% sodium tripolyphosphate) and the pH was adjusted to approximately 7.0 using 2 N NaOH. High protein solubility was observed at pH 3 and 12, while the highest protein recovery (80%) was at pH 12. The highest hydrophobicity was reported at pH 2. Total and reactive sulfhydryl (SH) concentration decreased as the pH increased from 10.5 to 12. The highest activities of cathepsin L-like enzymes were found at pH 10.5, whereas cathepsin B-like enzymes were highly activated with acid treatment. The best textural properties (breaking force, deformation) were recorded at pH 11 and 2, whereas the worst texture at pH 10.5 (Kim *et al.*, 2003) (Figure 14.14).

Hake (*M. hubbsi*) filleting waste was minced, mixed with water and autolyzed at 60°C. After centrifugation the supernatant was freeze-dried to obtain solid fish protein

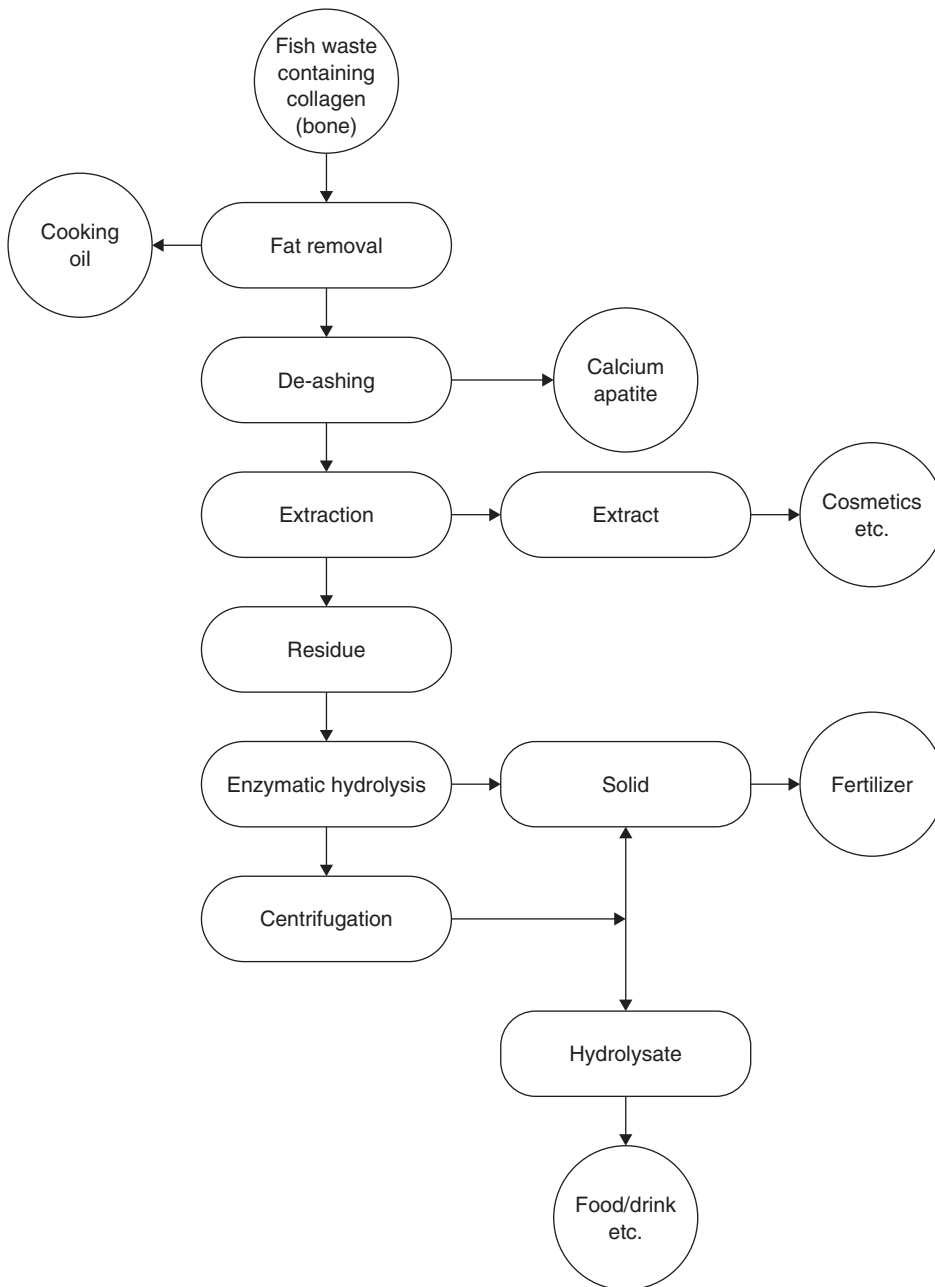

Figure 14.13 Flow diagram of the total procedure for extraction of protein and production of peptides by enzymatic hydrolysis from fish bone (adapted from Morimura *et al.*, 2002; Arvanitoyannis and Kassaveti, 2007)

hydrolysate (FPH). The produced FPH, contained 80% protein and the low free amino acid content appeared to have a significant nutritional value to support growth of bacteria and archaea. It can be concluded that FPH can be utilized as an alternative substrate for microorganism cultural purposes (*Halobacterium salinarum*, *Escherichia coli*, *Bacillus subtilis* and *Staphylococcus epidermidis*) (Martone *et al.*, 2005).

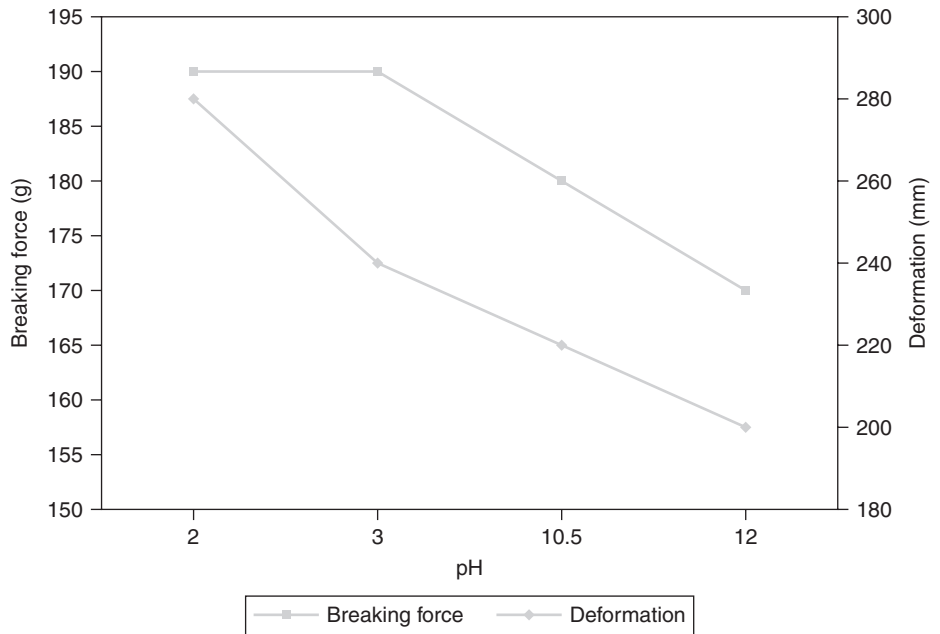

Figure 14.14 Textural properties of fish protein gels prepared after various treatments. Samples were treated at various pH conditions during protein recovery and then adjusted to pH 7.0 (adapted from Kim *et al.*, 2003)

Waste management

Fish bone, obtained from a natural Japanese sea bream, was heated at 600°C for 24 h or 900°C for 12 h and then a removal test was conducted by adding the produced powder to nitrate solutions with aqueous chromium (Cr^{3+}) concentration $3 \times 10^{-4}/\text{M}$. The mixture was stirred and soaked for 2 h and then held for 6 days without stirring. Chromium concentration in the solution was measured by inductively coupled plasma atomic emission spectrometer. Fish bone heated at 600°C displayed better removal capacity, while raw bone and bone powder heated at 900°C were of lower and similar activity, respectively. Raw fish bone had low crystallinity, the bone sample heated at 600°C was well-crystallized hydroxyapatite and the sample heated at 900°C revealed the development of high crystallinity of hydroxyapatite. The results confirmed the potential utilization of heated (600 or 900°C) fish bone for Cr-immobilization (Ozawa *et al.*, 2003).

Stepnowski and coworkers (2004) conducted sorption experiments using dry scales from redfish (*Sebastes marinus*) packed without pressure in 10–70 cm long PE columns supported with a reservoir filled with wastewater from shrimp factory for 5 h at room temperature. The results showed that 88–95% of astaxanthin in its esterified form was bound to the scales and the maximum loading capacity (362 mg/kg dry wt) was found to be 25–35 cm of suspension on top of the scales. Furthermore, slowing down the outflow of wastewater passing through the scales increased the percent of astaxanthin retention onto the scales even to the range of 90–97%. However, the latter prolonged the time of the process. It was concluded that fish scales can be utilized as a natural adsorbent for a carotenoid pigment (astaxanthin) from the seafood industry wastewater.

Miscellaneous uses

Mohan *et al.* (1993) utilized fishmeal waste as an attractant for economically important flies of agricultural crops, such as sorghum shoot fly (*Atherigona soccam* Rond.), moringa fruit fly (*Gitona* spp.) and the Indian uzifly (*Exorista bombycis* (Louis)) attacking mulberry silkworm. The waste fishmeal material was dried, powdered, moistened in polyethylene bags with a piece of cotton dipped in an insecticide (Dichlorvos 76 sc) and placed in fields. Female flies were shown to be attracted and nearly 50% of them were carrying eggs.

Composting experiments of fish offal (heads, skin, viscera and skeleton) from rainbow trout and wood by-products were conducted by Laos and coworkers (1998). Fish offal was mixed with bulking agent (a mixture of sawdust and wood shavings (1:1 by volume)) at a 3:1 ratio by weight. The blend was placed in an open structure with passively aerated method (Liao *et al.*, 1995), moisture ranging between 40 and 60% and temperature above 45°C. Samples were taken at 20, 30, 40, 60, 80 and 100 days after composting and dried at 60°C. Mature compost was used as amendment in different types of soils and the mixtures were incubated aerobically at 25°C, 20–30 percent soil moisture and no light for 16 weeks. Compost pH, extractable P and total nitrogen (TN) did not show a clear trend, whereas a decline in electric conductivity (EC), total organic carbon (TOC), NH₄-N and water-soluble carbon (WSC) was reported. The volatile fatty acids (VFA) also decreased to non-detectable values in the case of butyric, isobutyric and propionic acids, but the acetic acid trend was erratic. Compost showed higher release of available N at a constant rate of 12% and less soil retention of bioavailable P.

Anderson *et al.* (1999) examined the possibility of benthic *Gracilaria* population grown close (1.5 km and in the waste plume) to a fish-factory waste release site and 3.5 km away (control site) during 1996. In October–November, all the *Gracilaria* at the control site died, whereas growth at the fish waste site was 8–10% per day. In November–December control plants grew slightly faster than those from the waste site, in February the reverse occurred and in March–June growth was similar at both sites. A considerable uptake of the fish-waste N by *Gracilaria*, even at the control site, was reported. It was thus concluded that fish waste provided an important source of nitrogen for seaweed cultivation.

Casani *et al.* (2006) examined the potential of water re-use obtained in a shrimp processing line. Iced shrimps, *Pandalus borealis*, stored for maturation, were de-iced, rinsed and steam cooked. Then, the cooked shrimps were conveyed to a peeling machine and the edible meat was carried to a scrubber and finally brined and packed. The water recovered from peeling was screened, prefiltrated and treated by means of reverse osmosis (RO). The results revealed that quality of the treated water was higher than that of drinking water. Despite the considerable advantages of water re-use, the capital cost for the treatment equipment was too high for routine operation.

Table 14.8 provides a synoptic presentation of fish waste treatment methods, applied substrates, physicochemical characteristics and final product applications/uses.

Table 14.8 Fish waste: treatment method and physicochemical characteristics, substrate to be applied and final product uses

No	Substrate to be applied	Treatment method	Physicochemical characteristics	Final product/uses	References
<i>A Animal feed</i>					
1	Trout offal (heads, skeletons, tails and intestines)	Mincing, homogenization, pellets preparing of experimental diets	Low microbiological load (10^4 cfu/g), good lipid source due to total n-3 highly unsaturated fatty acids (HUFA) and arachidonic acid 20:4n-6 (AA) levels, main drawback the high level of 18:2n-6 fatty acid of trout intestine	Dietary ingredient of gilthead bream <i>Sparus aurata</i> (L.)	Kotzamanis <i>et al.</i> , 2001
2	Fish waste (mainly heads, bones, skin, viscera and sometimes whole fish and parsley)	Heat treatment at 65, 80, 105 and 150°C for 12 h for moisture content reduction to 10–12%	High source of minerals, 58% protein, 19% fat, detection of toxic substances (As, Pb, Hg and Cd) at non-problematic concentrations, decrease of waste digestibility with temperature	Feedstuff in swine diets as a protein substitute	Esteban <i>et al.</i> , 2007
3	Sardine fish waste	Chopped, mixed with 15% molasses, inoculated with <i>Lactobacillus plantarum</i> , and incubated at 22°C for 20 days. Incorporation with bran and barley	pH decrease in fermenting product (then remained constant at 4.2–4.5), slight total nitrogen decrease (5.3–5.7%), non-protein nitrogen increase (220–262%).	Can be used as a nitrogen source and possibly as a probiotic ingredient for poultry feeding	Hammoumi <i>et al.</i> , 1998
4	Shrimp head waste	Lime treatment at different temperatures (75, 100, 125°C) and lime/shrimp ratios (0, 0.05, 0.1, 0.2 g $\text{Ca}(\text{OH})_2/\text{g}$ dry shrimp)	20% ash, 10.3% TKN corresponding to 64% crude protein and chitin, 18% lipids and other compounds, little amino acid degradation	1 Protein-rich material can be used as a monogastric animal feed supplement 2 Residual solid – rich in calcium carbonate and chitin – can be used to generate chitin and chitosan	Coward-Kelly <i>et al.</i> , 2006
<i>B Biodiesel/biogas</i>					
5	Raw fish oil	Filtration pretreatment with or without the presence of two catalysts (iron oxide and calcium phosphate monobasic) and ozone treatment (5 g/h, 16 g/m^3 (about 8000 ppm)) at room temperature for 1 h and 30 min, respectively	Almost identical HHV (10 00 kcal/kg) and lower flash and pour points (37°C and –16°C, respectively) compared to commercial diesel fuel, no production of sulfur oxides, lowered or no soot, polyaromatic and carbon dioxide emissions	Biodiesel fuel for transportation	Kato <i>et al.</i> , 2004

6	Fish-farm effluents	Small-scale closed system with partially recirculated water consisting of two fish tanks with a recirculation rate of 60% and a rainbow trout daily feeding allowance 1, 1.5 and 2% of live weight, an up-flow anaerobic digester connected with a sedimentation column and equipped with an aerobic filter run at psychrophilic conditions (24–25°C) and with hydraulic retention time 22–38 days, a zeolite column for final treatment of effluents, a gas flow meter and a methane analyzer	49.8–144.2 l/day and 39.8–115.4 l/day biogas and methane production, highest biogas and methane production at the highest feeding allowance, >80% biogas methane content at 2% feeding allowance, reduction of VS (92–97%), SS (96–99%), TAN content (59–70%) and COD (45%) in the anaerobic digester; improved water quality of effluent by zeolite ion-exchange column	Biogas can be used directly in a burner to produce thermal energy or, following depuration, can be employed as fuel in a cogeneration plant to obtain thermal and electrical or mechanical energy	Lanari and Franci, 1998
7	Sludge from salmon smolt hatching	Mesophilic anaerobic treatment in a continuous stirred tank reactor (CSTR) at 35°C and 55–60 days hydraulic retention time (HRT)	<ol style="list-style-type: none"> 1 Treated sludge characteristics: 32% nitrogen, 8.5% phosphorus, low potassium content, acceptable concentration of heavy metal apart from zinc, high levels of volatile fatty acids (VFA) that may cause phytotoxicity, fertilizing value of 1 ton treated sludge 3.2–6.4 kg N and 1.2–2.4 kg P, 44.8–53.5% COD reduction 2 Methane yields 0.14–0.15 l/g COD, net energy production from the biogas 1 million smolts 43–47 MW h/year 	<ol style="list-style-type: none"> 1 Treated sludge may cause phytotoxicity – requirements for special means of application 2 Biogas can cover 2–4% energy demands of a flow-through hatchery 	Gebauer and Eikebrokk, 2006
<i>C Natural pigments</i>					
8	Shrimp waste	Extraction of shrimp waste carotenoids using different organic solvents and solvent mixtures at various extraction conditions	Highest carotenoids yield (43.9 gm/g waste) obtained when the carotenoids were extracted with a mixture of IPA and hexane, followed by IPA (40.8g/g) and acetone (40.6 [gm] g/g) Lowest carotenoid yield obtained with petroleum ether (12.1 µg/g) and hexane (13.1 µg/g)	<ol style="list-style-type: none"> 1 Carotenoids recovered from shrimp waste may be used instead of synthetic carotenoids in aquaculture feed formulations 2 The residue available after carotenoids extraction may be used for the preparation of chitin/chitosan 	Sachindra <i>et al.</i> , 2006

(Continued)

Table 14.8 (Continued)

No	Substrate to be applied	Treatment method	Physicochemical characteristics	Final product/uses	References
9	Fish fertilized eggs, week-old fry, month-old fry, 4-month old fry, one-year old fry and marketable carp	Carotenoid pigments extraction by 95% acetone in a dark room, saponification by means of 10% KOH in ethanol at 20°C for 24 h in the dark in a nitrogen atmosphere, followed by columnar and thin-layer chromatography	—	Carotenoids recovery (astaxanthin, β -, γ -, η - carotene, tunaxanthin, isozeaxanthin, phoenicoxanthin, canthaxanthin etc.)	Czczuga, 1979
<i>D Food industry/cosmetics</i>					
10	Fish myofibrils	Shrimp head protein hydrolysates (SHPH) were obtained according to Iwamoto <i>et al.</i> (1991) with some modifications. Fish myofibrils preparation was according to Katoh <i>et al.</i> (1977) with some modifications by Nozaki <i>et al.</i> (1991)	SHPH characteristics: suppress dehydration – induced denaturation of myofibrillar protein by hydrated water stabilization, decrease Ca-ATPase inactivation and increase monolayer sorbed water, multilayer sorbed water of myofibril	Food additive to suppress the denaturation of myofibrillar protein and maintain moisture in intermediate moisture foods	Ruttanapornvareesakul <i>et al.</i> , 2005, 2006
11	Shrimp heads	Protease extracted from shrimp waste, purified, dissolved in PBS (pH 7.4), added to raw beefsteaks, incubated for 1 h at 10°C, cooked at 70°C, cooled and stored at 4°C for 24 h, prior to shear force analysis	Overdegradation of meat proteins, efficient at low temperatures – energy minimization, enzyme inactivation after mild heat treatment	Meat industry – beef tenderization	Aoki <i>et al.</i> , 2004
12	Lizard fish surimi	Fish scrap (head, viscera, scale, skin, caudal fin and bone) was treated according to Iwamoto <i>et al.</i> (1991) with some modifications. Minced lizard fish meat was mixed with 5.0% (dry weight/wet weight) FPH, the moisture was adjusted to 82.0% and stored at –25°C for 180 days	FPH components: peptide (11.5–16.3%) and other nitrogenous compounds (82.3–85.8%), high gel-forming ability and Ca-ATPase activity, suppression of decrease of unfrozen water content	Cryoprotectant for suppression of denaturation of muscle protein of lizard fish meat during frozen storage	Khan <i>et al.</i> , 2003
13	Tuna fish waste	Tuna fish gastric proteases were isolated using 25% NaCl	Similar enzyme activity with standard rennet at pH 4.0–6.0, less sensitive	Rennet substitute	Tavares <i>et al.</i> , 1997

		solution (w/v) at different holding times (0–3 h), prior to the enzyme activation at pH 5.0. Proteases yield was examined at 4°C and room temperature	to losses of activity than rennet at pH > 6.4, unstable at pH > 7.0, loss of activity at pH > 8.0, similar milk-coagulating time with standard rennet at incubation temperature 32°C and pH 5.5–6.4		
14	Lizard fish myofibrils	Protein hydrolysate from Antarctic krill meat was obtained according to Iwamoto <i>et al.</i> (1991). The myofibrils were homogenized, filtered, lipid and salts were removed and mixed with hydrolysates, glucose and sodium glutamate (5% dry weight/100 g pelleted myofibrils as wet weight). The mixture was dehydrated at 5°C and when the moisture content reached 10%, further dehydration conducted	1 Hydrolysate main components: crude protein, crude ash, sugar content, sodium chloride at traces, and amino acids (Glx, Asx, Arg, Lys, Gly, Ala, and Leu) 2 Antarctic krill hydrolysates stabilized bonding of water molecules and suppressed denaturation	Suppressive additives against denaturation of myofibrillar protein and as reagent to maintain moisture in food	Zhang <i>et al.</i> , 2002
15	Fish skin, bone and fin	Collagen isolation	36–54% collagen recovery and denaturation temperatures of skin collagen ($25.0 \pm 26.5^\circ\text{C}$), bone collagen ($29.5 \pm 30.0^\circ\text{C}$) and fin collagen ($28.0 \pm 29.1^\circ\text{C}$)	Use as alternatives to mammalian collagen in foods, cosmetics and biomedical materials	Nagai and Suzuki, 2000
16	Waste collagenous materials from fish (muscle and skin of hake and trout)	Stirring, filtration, storage at 3–5°C for 24 h, dilution of collagenous material/solvent at 1:6 (w/v) (NaCl concentrations: 0, 1.0%, 1.5%, 2.0%, 3.0% and 6.0%). The pH levels studied in the absence of NaCl were 1–7 (adjustment with NaOH or HCl)	Trout skin had the highest collagen concentration at various pH and NaCl conditions, whereas hake muscle had the lowest collagen concentration, NaCl did not affect the gel-forming capacity of muscle collagenous material, diminution of skin collagenous material, pH values close to neutral gel strength is greater than in acidic media	Gelifying material in food industry	Montero and Borderias, 1990
17	Fish bone wastes	Pretreated (fat removal, de-ashing), treated enzymatically, agitated at 200 rpm for 60 min at 60°C and pH 8.0, centrifuged at 8000g for 10 min and the precipitate weight was measured after drying at 105°C for 24 h	50% collagen recovery, high water retention capacity, high anti-radical activity, amino acid composition	1 Extract: used as cosmetic material, ability to repair rough skin, lack of any odor problem and absence of harmful effects on skin 2 Hydrolysate: used as food additive, high 12	Morimura <i>et al.</i> , 2002

(Continued)

Table 14.8 (Continued)

No	Substrate to be applied	Treatment method	Physicochemical characteristics	Final product/uses	References
				potential for lowering high blood pressure	
				3 Fat and inorganic materials from pretreatment: production of cooking oil and calcium apatite, respectively	
				4 Solid from extraction process: used as fertilizer	
18	Fish fillets	Fillets were subjected to acid-aided (pH 2 and 3) or alkali-aided (pH 10.5, 11 and 12) processing methods (at <math><5^{\circ}\text{C}</math>). Fish proteins were then mixed with cryoprotectants (5% sucrose, 4% sorbitol and 0.3% sodium tripolyphosphate) and the pH was adjusted to 7.0 using 2 N NaOH	High protein solubility at pH 3 and 12, highest protein recovery (80%) at pH 12, highest hydrophobicity at pH 2, total and reactive sulfhydryl (SH) concentration decreased as the pH increased from 10.5 to 12, highest activities of cathepsin L-like enzymes at pH 10.5, cathepsin B-like enzymes highly activated at acid treatment, best textural properties (breaking force, deformation) at pH 11 and 2, worst texture at pH 10.5	Fish proteins recovery	Kim <i>et al.</i> , 2003
<i>E Waste management</i>					
19	Fish bone waste	Heat treatment of raw bone at 600°C for 24 h or 900°C for 12 h	Better removal capacity and well-crystallized hydroxyapatite at 600°C, raw bone showed lower activity and crystallinity, bone sample heated at 900°C showed similar activity with raw bone and developed crystallinity of hydroxyapatite	Cr-immobilization (when treated at 600°C)	Ozawa <i>et al.</i> , 2003
20	Fish scales and wastewater	Sorption experiments using dry scales packed without	88–95% bond of asthaxanthin to scales, maximum loading capacity	Natural adsorbent for a carotenoid pigment	Stepnowski <i>et al.</i> , 2004

		pressure in 10–70 cm long PE columns supported with a reservoir filled with wastewater (5 h, at room temperature)	(362 mg/kg dry wt) at 25–35 cm of suspension on top of scales, 90–97% astaxanthin retention onto scales by slowing down the out-flow of wastewater	(astaxanthin) from the seafood industry wastewater	
<i>F Miscellaneous use</i>					
21	Fishmeal waste	The waste fishmeal material was dried, powdered, moistened in polythene bags with a piece of cotton dipped in an insecticide (Dichlorvos 76 sc) and placed in fields	Female flies were attracted and nearly 50% of them were carrying eggs	Attractant for economically important flies of agricultural crops (sorghum shoot fly (<i>Atherigona soccam</i> Rond.), moringa fruit fly (<i>Gitona</i> spp.) and the Indian uzifly (<i>Exorista bombycis</i> (Louis) attacking mulberry silkworm)	Mohan <i>et al.</i> , 1993
22	Fish offal (heads, skin, viscera and skeletons of rainbow trout)	Composting of fish offal and bulking agent (a mixture of sawdust and wood shavings (1:1 by volume)) at a 3:1 ratio by weight using a passively aerated method (moisture 40–60%, 45°C)	pH, extractable P and total nitrogen (TN) did not show a clear trend; electric conductivity (EC), total organic carbon (TOC), NH ₄ -N and water-soluble carbon (WSC) decline, volatile fatty acids (VFA) decrease to non-detectable values, release of available N at a constant rate of 12% and less soil retention of bioavailable P	Soil amendment	Laos <i>et al.</i> , 1998
23	Fish-factory waste	Release of large quantities of nitrogen-rich fish waste	Significant source of N for cultivated seaweed (<i>Gracilaria gracilis</i>)	Nitrogen removal introduced by the fish-factories	Anderson <i>et al.</i> , 1999
24	Shrimp	Wastewater (from shrimp process) recycling with RO membranes	Higher quality than drinking water	Drinking water	Casani <i>et al.</i> , 2006

Adapted from Arvanitoyannis and Kassaveti, 2007

Inputs and outputs in fisheries

Fish production can generate considerable amounts of effluent, such as waste feed and feces, medications and pesticides, which can have undesirable impacts on the environment (Gowen and Bradbury, 1987; Ackefors and Enell, 1994; Wu, 1995; Axler *et al.*, 1996; Kelly *et al.*, 1996). Fish farm effluent is often discharged directly into shallow coastal habitats determining organic and nutrient loads (mainly carbon, nitrogen and phosphorus as feed components, excreta and feces) (Alabaster, 1982). Minimization and enforced reduction of pollutant loads from point-source aquatic animal production facilities are increasingly demanded by various segments of the public and the regulatory community (MacMillan *et al.*, 2003).

Water is used for treating and transporting fish, for cleaning equipment and work areas and for fluming offal and blood. Automated processing equipment has permanently installed water sprays to keep equipment clean and to flush offal away. Rates of water consumption can vary considerably depending on the scale and age of the plant, the type of processing, the level of automation and the ease with which equipment can be cleaned, as well as operator practices (<http://www.earthprint.com/unep/download/2481.pdf>).

In fisheries, energy is used for operating machinery, producing ice, heating, cooling and drying. Apart from depleting fossil fuel resources, the consumption of energy also produces air pollution and greenhouse gas emissions, closely linked to global warming. Production of fishmeal and fish oil requires significant amounts of energy for cooking, drying and evaporation. This energy is usually generated by the combustion of fuels on site (http://www.agrifood-forum.net/publications/guide/f_chap4.pdf).

The solid wastes from fish farms falling to the seabed below fish cages are enriched in carbon, nitrogen and phosphorus relative to the natural sediments, hence fish farming may considerably alter the physicochemical nature of sediments below and adjacent to the operation, but is usually limited to the vicinity (50 m) of the cages. This increase in carbon sedimentation results in greater oxygen consumption by bottom-living animals. The sediments will become anoxic (i.e. contain no oxygen) if this additional oxygen demand exceeds oxygen supply, at which point there may be severe consequences for both benthic organisms and the fish farming itself (http://www.gpavlineris.com/id29_m.htm).

Although smoke and particulates may be a problem, odors are the most objectionable emissions from fish processing plants. The largest odor source in the fish by-products segment is the fishmeal driers. Odorous gases from reduction cookers consist primarily of hydrogen sulfide (H₂S) and trimethylamine [(CH₃)₃N] but are emitted from this stage in appreciably smaller volumes than from fishmeal driers. Some odors are also released by the canning processes. Fish cannery and fish by-product processing odors can be controlled by means of afterburners, chlorinator-scrubbers or condensers (<http://www.epa.gov/ttn/chief/ap42/ch09/final/c9s13-1.pdf>). Both inputs and outputs of various fish processes are summarized in Table 14.9.

Table 14.9 Inputs and outputs of various fish processes

Process	Inputs		Outputs	
	Fresh or frozen fish (kg)	Energy	Wastewater	Solid waste (kg)
White fish filleting	1000	Ice: 10–12 kWh Freezing: 50–70 kWh Filleting: 5 kWh	5–11 m ³ : BOD 35 kg COD ₅ 50 kg	Skin: 40–50 Heads: 210–250 Bones: 240–340
Oily fish filleting	1000	Ice: 10–12 kWh Freezing: 50–70 kWh Filleting: 2–5 kWh	5–8 m ³ : BOD 50 kg COD ₅ 85 kg Nitrogen 2.5 kg N Phosphate 0.1–0.3 kg P	400–450
Canning	1000	150–190 kWh	15 m ³ : BOD 52 kg COD ₅ 116 kg Nitrogen 3 kg N Phosphate 0.1–0.4 kg P	Heads/entrails: 250 Bones: 100–150
Fishmeal and fish oil production	1000	Fuel: 49 l Electricity: 32 kWh	–	–
Frozen fish thawing	1000	–	5 m ³ : COD ₅ 1–7 kg	–
De-icing and washing	1000	0.8–1.2 kWh	1 m ³ : COD ₅ 0.7–4.9 kg	0–20
Grading	1000	0.1–0.3 kWh	0.3–0.4 m ³ : COD ₅ 0.4–1.7 kg	0–20
Scaling of white fish	1000	0.1–0.3 kWh	10–15 m ³	Scales: 20–40
De-heading of white fish	1000	0.3–0.8 kWh	1 m ³ : COD ₅ 2–4 kg	Heads and debris: 270–320
Filleting of de-headed white fish	1000	1.8 kWh	1–3 m ³ : COD ₅ 4–12 kg	Frames and offcuts: 200–300
Filleting of un-gutted oily fish	1000	0.7–2.2 kWh	1–2 m ³ : COD ₅ 7–15 kg	Entrails, tails, heads and frames: 400
Skinning white fish	1000	0.4–0.9 kWh	0.2–0.6 m ³ : COD ₅ 1.7–5.0 kg	Skin: 40
Skinning oily fish	1000	0.2–0.4 kWh	0.2–0.9 m ³ : COD ₅ 3.0–5.0 kg	Skin: 40
Trimming and cutting white fish	1000	0.3–3.0 kWh	0.1 m ³	Bones and cut-off: 240–340
Packaging of fillets	1000	5.0–7.5 kWh	–	–
Freezing and storage	1000	10.0–14.0 kWh	–	–
Unloading fish for canning	1000	3.0 kWh	2.0–5.0 m ³ : COD ₅ 27.0–34.0 kg	–
Grading of fish	1000	0.15 kWh	0.2 m ³ : COD ₅ 0.35–1.7 kg	0.3
Nobbing and packing in cans	1000	0.4–1.5 kWh	0.2–0.9 m ³ : COD ₅ 7.0–15.0 kg	Heads and entrails: 150 Bones and meat: 100–150
Skinning of nobbed fish	1000	–	17.0 m ³ : COD ₅ 3.0–5.0 kg	Skin: 55

(Continued)

Table 14.9 (Continued)

Process	Inputs		Outputs	
	Fresh or frozen fish (kg)	Energy	Wastewater	Solid waste (kg)
Precooking of fish to be canned	1000	0.3–1.1 kWh	0.07–0.27 m ³	Inedible parts: 150
Draining of cans containing precooked fish	1000	0.3 kWh	0.1–0.2 m ³ : COD ₅ 3.0–10.0 kg	–
Sauce filling	1000	–	–	Spillage of sauce and oil: varies
Can sealing	1000	5.0–6.0 kWh	–	–
Washing of cans	1000	7.0 kWh	0.04 m ³	–
Sterilization of cans	1000	230 kWh	3.0–7.0 m ³	–
Handling and storage of fish	1000	10.0–12.0 kWh	COD ₅ 130.0–140.0 kg	–
Unloading of fish	1000	3.0 kWh	2.0–5.0 m ³ : COD ₅ 27.0–34.0 kg	–
Cooking of fish	1000	90.0 kWh	–	–
Pressing the cooked fish	1000	–	750 kg water 150 kg oil	Press cake: 100 kg dry matter
Drying of press cake	1000	340.0 kWh	–	–
Fish oil polishing	1000	Hot water	0.05–0.1 m ³ : COD ₅ 5 kg	–
Stickwater evaporation	1000	475.0 kWh	–	Concentrated stickwater: 250 Dry matter: 50

Adapted from http://www.agrifood-forum.net/publications/guide/f_chap4.pdf; http://www.agrifood-forum.net/publications/guide/f_chp3.pdf, Arvanitoyannis and Kassaveti, 2007

References

Scientific references

- Abazinge, M.D.A., Fontenot, J.P., Allen, V.G. and Flick, G.J. (1993). Ensiling characteristics of crab waste and wheat straw treated with different additives. *J Agricult Food Chem* **41**, 657–661.
- Ackefors, H. (1986). The impact on the environment by cage farming in open water. *J Aquacult Tropics* **1**, 25–33.
- Ackefors, H. and Enell, M. (1990). Discharge of nutrients from Swedish fish farming to adjacent sea areas. *Ambio* **19**, 29–35.
- Ackefors, H. and Enell, M. (1994). The release of nutrients and organic matter from aquaculture systems in Nordic countries. *J Appl Ichthyol* **10**(4), 225–241.
- Aidos, I., van der Padt, A., Boom, R.M. and Luten, J.B. (2001). Upgrading of maatjes herring byproducts: production of crude fish oil. *Food Chem* **49**, 3697–3704.

- Aidos, I., Vis-Smit, R. S., Veldman, M., Luten, J.B., van der Padt, A. and Boom, R.M. (2003). Chemical and sensory evaluation of crude oil extracted from herring by-products from different processing operations. *Food Chem* **51**, 1897–1903.
- Alabaster, J.S. (1982). Report of the EIFAC workshop on fish farm effluents. *EIFAC Technical Paper*, 41.
- Alcantra, R., Amores, J., Canoira, L., Fidaldo, E., Franco, M.J. and Navarro, A. (2000). Catalytic production of biodiesel from soy-bean oil used frying oil and tarrow. *Biomass Bioenergy* **18**, 512–527.
- Ali, N., Mohammad, A.W., Jusoh, A., Hasan, M.R., Ghazali, N. and Kamaruzaman, K. (2005). Treatment of aquaculture wastewater using ultra-low pressure asymmetric polyethersulfone (PES) membrane. *Desalination* **185**, 317–326.
- American Public Health Association (APHA) (1998). *Standard methods for examination of water and waste water*, p. 1192. APHA, Washington, DC.
- American Public Health Association (APHA) (1995). *Standard methods for examination of water and waste water*, 19th edn. APHA, Washington, DC.
- American Public Health Association (APHA) (1992). *Standard methods for examination of water and waste water*. American Public Health Association, Washington, DC.
- American Public Health Association (APHA) (1989). *Standard methods for examination of water and waste water*, 17th edn. APHA, Washington, DC.
- American Public Health Association (APHA) (1985). *Standard methods for the examination of water and wastewater*, 14th edn. American Public Health Association, Washington, DC.
- American Public Health Association (APHA) (1975). *Standard methods for examination of water and waste water*, 4th edn. APHA, Washington, DC.
- Anderson, R.J., Smit, A.J. and Levitt, G.J. (1999). Upwelling and fish-factory waste as nitrogen sources for suspended cultivation of *Gracilaria gracilis* in Saldanha Bay, South Africa. *Hydrobiologia* **398/399**, 455–462.
- Anon. (1980). *Official methods of analysis of the Association of Official Analytical Chemists*, 13th edn (W. Horvitz, ed.). Association of Official Analytical Chemists, Washington, DC.
- Aoki, H., Ahsan, Md.N., Matsuo, K., Hagiwara, T. and Watabe, S. (2004). Partial purification of proteases that are generated by processing of the Northern shrimp *Pandalus borealis* and which can tenderize beef. *Int J Food Sci Technol* **39**, 471–480.
- APHA-AWWA-WPCF (1985). *Metodos normalizados para el analisis de las aguas potables y residuales*. Díaz de Santos, Madrid.
- Arvanitoyannis, I., Kolokuris, I., Nakayama, A., Yamamoto, N. and Aiba, S. (1997). Physicochemical studies of chitosan-poly (vinyl alcohol) blends plasticized with sorbitol and sucrose. *Carbohydr Polym* **34**(1/2): 9–19.
- Arvanitoyannis, I., Nakayama, A. and Aiba, S. (1998). Chitosan and gelatin based edible films: state diagrams, mechanical and permeation properties. *Carbohydr Polym* **37**, 371–382.
- Arvanitoyannis, I.S. and Kassaveti, A. (2007). Treated waste fish: environmental treatment, current and potential uses. *Int J Food Sci Technol* (in press).
- Aspila, K.I., Agemian, H. and Chau, A.S.Y. (1976). A semi automated method for the determination of inorganic, organic and total phosphate in sediments. *Analyst* **101**, 187–197.

- Association of Official Analytical Chemists (AOAC) (1980). *Official methods of analysis*, 14th edn. Association of Official Analytical Chemists, Washington, DC.
- Association of Official Analytical Chemists (AOAC) (1984). *Official methods of analysis*, 14th edn. Association of Official Analytical Chemists, Arlington, VA.
- Association of Official Analytical Chemists (AOAC), (1990). *Official methods of analysis*, 13th edn. Association of Official Analytical Chemists, Arlington, VA.
- Axler, R., Larsen, C., Tikkanen, C., McDonald, M., Yokom, S. and Aas, P. (1996). Water quality issues associated with aquaculture: a case study in mine pit lakes. *Water Environ Res* **68**(6), 995–1011.
- Ayangbile, G.A., Fontenot, J.P., Kirk, D.J., Allen, V.G. and Flick, G.J. (1997). Effects of chemicals on preservation of crab-processing waste and fermentation characteristics of the waste-straw mixture. *Food Chem* **45**, 3622–3626.
- Barker, S.D. and Summerson, W.H. (1941). The colorimetric determination of lactic acid in biological material. *J Biol Chem* **138**, 535–554.
- Barnhart, R.A. (1969). Effects of certain variables on hematological characteristics of rainbow trout. *Trans Am Fish Soc* **98**, 411–418.
- Batista, I. (1999). Recovery of proteins from fish waste products by alkaline extraction. *Eur Food Res Technol* **210**, 84–89.
- Bjornsson, L., Murto, M. and Mattiasson, B. (2000). Evaluation of parameters for monitoring an anaerobic co-digestion. *Appl Microbiol Biot* **54**, 844–849.
- Buryniuk, M., Petrell, R.J., Baldwin, S. and Lo, K.V. (2005). Accumulation and natural disintegration of solid wastes caught on a screen suspended below a fish farm cage. *Aquacult Engin* (in press).
- Cancino, J. and Orellana, M.C. (1987). Interaction entre *Gracilaria rerrucosa* y su fauna epifita: perspectivas para la utilizacion de mitilidos coma fuente de nutrientes en cultivos de *Gracilaria* en piscinas litorales. In *Investigation Acuicola en America Latina* (J.A.J. Verreth, M. Carillo, S. Zanuy and E.A. Huisman, eds), pp. 380–392. Pudoc, Wageningen.
- Casani, S., Leth, T. and Knochel, S. (2006). Water reuse in a shrimp processing line: safety considerations using a HACCP approach. *Food Control* **17**, 540–550.
- Castell, C.H., Smith, B. and Dyen, W.J. (1974). Simultaneous measurement of trimethylamine and dimethylamine in fish and their use for estimating quality of frozen-stored gadoid filets. *J Fish Res Board Can* **31**, 383–389.
- Cattaneo-Vietti, R., Benatti, U., Cerrano, C., Giovine, M., Tazioli, S. and Bavestrello, G. (2003). A marine biological underwater depuration system (MUDS) to process waste waters. *Biomolec Engin* **20**, 291–298.
- Chang, K.L.B. and Tsai, G. (1997). Response surface optimisation and kinetics of isolating chitin from pink shrimp (*Solenocera melantho*) shell waste. *Food Chem* **45**, 1900–1904.
- Clark, J.S., Pienaar, P.G., Wanger, L. and Schrock, W.D. (1983). Methyl ester and butyl soybean esters as a renewable fuel for diesel engines. *J Amer Oil Chem Soc* **60**, 735–736.
- Cobb, B.F., Alaniz, I. and Thompson, C.A. (1973). Biochemical and microbial studies on shrimp: volatile nitrogen and amino analysis. *J Food Sci* **38**, 431–440.
- Coello, N., Montiel, E., Concepcion, M. and Christen, P. (2002). Optimisation of a culture medium containing fish silage for L-lysine production by *Corynebacterium glutamicum*. *Bioresource Technol* **85**, 207–211.

- Conway, F. (1974). *Microdiffusion analysis and volumetric error*, pp. 157–159. Crosby Lockwood, London, U.K.
- Coward-Kelly, G., Agbogbo, F.K. and Holtzapple, M.T. (2006). Lime treatment of shrimp head waste for the generation of highly digestible animal feed. *Bioresource Technol* **97**, 1515–1520.
- Czeczuga, B. (1979). Carotenoids in fish. XXII. Changes in carotenoids in *Cyprinus carpio* L. *Hydrobiologia* **65**(3), 233–240.
- D'Aqaro, E. and Lanari, D. (2006). Environmental impact of sea bass cage farming in the north Adriatic Sea. *Italian Journal of Animal Science* **5**(2), 165–174.
- Diniz, F.M. and Martin, A.M. (1996). Use of response surface methodology to describe the combined effects of pH, temperature and E/S ratio on the hydrolysis of dogfish (*Squalus acanthias*) muscle. *Int J Food Sci Technol* **31**, 419–426.
- Dubois, M., Gilles, K.A., Hamilton, J.K., Rebers, P.A. and Smith, F. (1956). Colorimetric method for determination of sugars and related substances. *Anal Chem* **28**, 350–356.
- Duff, S.J.B. and van den Berg, L. (1982). Treatment of fish processing waste using the downflow stationary fixed film (DSFF) reactor. *Biotechnol Lett* **12**, 821–826.
- Dunn, O.R. and Bagby, M.O. (2000). Low-temperature phase behavior of vegetable oil co-solvent blends as alternative diesel fuel. *J Amer Oil Chem Soc* **77**, 1315–1323.
- Dyer, W.J. (1959). Report on trimethylamine in fish: colorimetric determination of trimethylamine. *J Assoc Off Anal Chem* **42**, 292–294.
- El-Beltagy, A.E., El-Adawy, T.A., Rahma, E.H. and El-Bedawey, A.A. (2005). Purification and characterisation of an alkaline protease from the viscera of boliti fish (*Tilapia nilotica*). *J Food Biochem* **29**, 445–458.
- Eleftheriou, A. and Eleftheriou, M. (2001). Legal and regulatory background to best environmental practice. In *The Implications of Directives, Conventions and Codes of Practice on the Monitoring and Regulation of Marine Aquaculture in Europe. Proceedings of the Second MARAQUA Workshop, 20–22 March 2000, Institute of Marine Biology, Crete* (P.A. Read, T.F. Fernandes, K.L. Miller *et al.*, eds), pp. 75–83. Scottish Executive, Aberdeen.
- Environmental Protection Agency (EPA), (1979). *Methods for chemical analysis of water and wastes. EPA-600/4-79-020*. Environmental Monitoring and Support Laboratory, US EPA, Cincinnati.
- Ervik, A., Hansen, P. K., Aure, J., Stigebrandt, A., Johannessen, P. and Jahnsen, T. (1997). Regulating the local environmental impact of intensive marine fish farming I. The concept of the MOM system (Modelling–Ongrowing fish farms–Monitoring). *Aquaculture* **158**, 85–94.
- Esteban, M.B., Garcia, A.J., Ramos, P. and Marquez, M.C. (2007). Evaluation of fruit–vegetable and fish wastes as alternative feedstuffs in pig diets. *Waste Manage* **27**(2), 193–200.
- Fahim, F.A., Fleita, D.H., Ibrahim, A.M. and El-Dars, F.M.S (2001). Evaluation of some methods for fish canning wastewater treatment. *Water Air Soil Pollut* **127**, 205–226.
- Faid, M., Karani, H., Elmarrakchi, A. and Achkari-Begdouri, A. (1994). A biotechnological process for the valorisation of fish waste. *Bioresource Technol* **49**, 237–241.
- FAO (2002). *FAO fisheries statistical yearbook 2002*. Food and Agricultural Organisation of the United Nations, Rome.

- FAOSTAT, FAO statistical databases, fisheries data (2001). Food and Agriculture Organisation of the United Nations, Rome (<http://www.fao.org>).
- Fiske, C.H. and Subbarow, Y. (1925). The calorimetric determination of phosphorus. *J Biol Chem* **66**, 375–400.
- Folch, J., Lee, M. and Sloane-Stanley, G.H. (1957). A simple method for isolation and purification of total lipids from animal tissues. *J Biol Chem* **225**, 497–509.
- Gabrielsen, B.O. and Austreng, E. (1998). Growth, product quality and immune status of Atlantic salmon, *Salmo salar* L. fed wet feed with alginate. *Aquacult Res* **29**, 397–401.
- Gao, M.-T., Hirata, M., Toorisaka, E. and Hano, T. (2006). Acid-hydrolysis of fish wastes for lactic acid fermentation. *Bioresource Technol* **97**(18), 2414–2420.
- Garcia-Sanda, E., Omil, F. and Lema, J.M. (2003). Clean production in fish canning industries: recovery and reuse of selected wastes. *Clean Techn Environ Policy* **5**, 289–294.
- Garrido, J.M., Guerrero, L., Méndez, R. and Lema, J.M. (1998). Nitrification of waste waters from fishmeal factories. *Water SA* **24**(3), 245–250.
- Gebauer, R. and Eikebrokk, B. (2006). Mesophilic anaerobic treatment of sludge from salmon smolt hatching. *Bioresource Technol* **97**(18), 2389–2401.
- Gildberg, A. and Stenberg, E. (2001). A new process for advanced utilisation of shrimp waste. *Process Biochem* **36**, 809–812.
- Gowen, R. and Bradbury, N.B. (1987). The ecological impact of salmonid farming in coastal waters: a review. *Oceanogr Mar Biol Ann Rev* **25**, 563–575.
- Gowen, R.J. (1991). Aquaculture and the environment. In *Aquaculture and the environment* (N. DePauw and J. Joyce, eds), pp. 30–38. European Aquaculture Society Special Publications No. 16, Ghent.
- Guerard, F., Dufosse, L., De La Broise, D. and Binet, A. (2001). Enzymatic hydrolysis of proteins from yellow fin tuna (*Thunnus albacares*) wastes using Alcalase. *J Mol Catal B: Enzym* **11**, 1051–1059.
- Haard, N.F. (1992). Biochemistry and chemistry of colour and colour change in seafood. In *Advances in seafood biochemistry: composition and quality* (G.J. Flick and R.E. Martin, eds), p. 305. Technomic Publishing Co. Inc., Lancaster.
- Hackman, R.H. and Goldberg, M. (1971). Studies on the hardening and darkening of insect cuticles. *J Insect Physiol* **17**, 335–347.
- Hakansson, L., Ervik, A., Makinen, T. and Miller, B. (1988). Basic concepts concerning assessments of environmental effects of marine fish farms. *Nordic council of ministers, Nord* **90**, 103.
- Hammoumi, A., Faid, M., El yachioui, M. and Amarouch, H. (1998). Characterisation of fermented fish waste used in feeding trials with broilers. *Process Biochem* **33**(4), 423–427.
- Hansen, P.K., Ervik, A., Schaaning, M. et al. (2001). Regulating the local environmental impact of intensive marine fish farming II. The monitoring programme of the MOM system (Modelling–Ongrowing fish farms–Monitoring). *Aquaculture* **194**, 75–92.
- Hospido, A., Vazquez, M.E., Cuevas, A., Feijoo, G. and Moreira, M.T. (2006). Environmental assessment of canned tuna manufacture with a life-cycle perspective. *Resources Conservat Recyc* **47**, 56–72.
- Hossain, M.A., Ishihara, T., Hara, K., Osatomi, K., Khan, M.D.A.A. and Nozaki, Y. (2003). Effect of proteolytic squid protein hydrolysate on the state of water and

- dehydration-induced denaturation of lizard fish myofibrillar protein. *J Agric Food Chem* **51**, 4769–4774.
- Hussenot, J., Lefebvre, S. and Brossard, N. (1998). Open-air treatment of wastewater from land-based marine fish farms in extensive and intensive systems: current technology and future perspectives. *Aquat Living Resour* **11**(4), 297–304.
- ISO/DIS (2000a). ISO 14042: Environmental Management – Life Cycle Assessment – Life Cycle Impact Assessment. Geneva.
- ISO/DIS (2000b). ISO 14043: Environmental Management – Life Cycle Assessment – Life Cycle Interpretation. Geneva.
- Iwama, G.K. (1991). Interactions between aquaculture and the environment. *Crit Rev Environ Conservat* **21**, 177–216.
- Iwamoto, M., Fujiwara, R. and Yokoyama, M. (1991). Immunological effects of BM-2, an enzymatic digestive extract of chub markerel. *J Jpn Soc Cancer Ther* **26**, 936–947.
- Johnson, R.R., Balwani, T.L., Johnson, L.J., McClure, K.E. and Dehority, B.A. (1966). Corn plant maturity. II. Effect on in vitro cellulose digestibility and soluble carbohydrate content. *J Anim Sci* **25**, 617–623.
- Jones, A.B., Dennison, W.C. and Preston, N.P. (2001). Integrated treatment of shrimp effluent by sedimentation, oyster filtration and macroalgal absorption: a laboratory scale study. *Aquaculture* **193**, 155–178.
- Kaluzny, M.A., Duncan, L.A., Merritt, M.V. and Epps, D.E. (1985). Rapid separation of lipid classes in high yield and purity using bonded phase columns. *J Lipid Res* **26**, 135–140.
- Kato, S., Kunisawa, N., Kojima, T. and Murakami, S. (2004). Evaluation of ozone treated fish waste oil as a fuel for transportation. *J Chem Engin Japan* **37**(7), 863–870.
- Katoh, N., Uchiyama, H., Tsukamoto, S. and Arai, K. (1977). A biochemical study on fish myofibrillar ATPase. *Nippon Suisan Gakkaishi* **43**, 857–867.
- Kelly, L.A., Stellwagen, J. and Berghheim, A. (1996). Waste loadings from a fresh-water Atlantic salmon farm in Scotland. *Water Res Bull* **32**(N5), 1017–1025.
- Khan, M.A.A., Hossain, M.A.A., Hara, K., Osatomi, K., Tadashi, I. and Yukinori, N. (2003). Effect of enzymatic fish-scrap protein hydrolysate on gel-forming ability and denaturation of lizard fish *Saurida wanieso* surimi during frozen storage. *Fish Sci* **69**, 1271–1280.
- Kim, Y.S., Park, J.W. and Choi, Y.J. (2003). New approaches for the effective recovery of fish proteins and their physicochemical characteristics. *Fish Sci* **69**, 1231–1239.
- Kolthoff, I.M. and Sandell, E.B. (1952). Argentimetric and mercurimetric determinations. In *Textbook of quantitative organic analysis*, pp. 545–546. Macmillan, New York.
- Kotzamanis, Y.P., Alexis, M.N., Andriopoulou, A., Castritsi-Cathariou, I. and Fotis, G. (2001). Utilisation of waste material resulting from trout processing in gilthead bream (*Sparus aurata* L.) diets. *Aquacult Res* **32**(Suppl. 1), 288–295.
- Kristinsson, H.G. and Rasco, B.A. (2000a). Fish protein hydrolysates: production, biochemical and functional properties. *CRC Crit Rev Food Sci Nutr* **40**(1), 43–81.
- Kristinsson, H.G. and Rasco, B.A. (2000b). Biochemical and functional properties of atlantic salmon (*Salmo salar*) muscle proteins hydrolyzed with various alkaline proteases. *Food Chem* **48**, 657–666.
- Lanari, D. and Franci, C. (1998). Biogas production from solid wastes removed from fish farm effluents. *Aquat Living Resour* **11**(4), 289–295.

- Laos, F., Mazzarino, M.J., Walker, I., Roselli, L., Satti, P. and Moyano, S. (2002). Composting of fish offal and biosolids in northwestern Patagonia. *Bioresource Technol* **81**, 179–186.
- Laos, F., Mazzarino, M.J., Walter, I. and Roselli, L. (1998). Composting of fish waste with wood by-products and testing compost quality as a soil amendment: experiences in the Patagonia region of Argentina. *Compost Sci Util* **6**(1), 59–66.
- Larsen, T., Thilsted, S.H., Kongsback, K. and Hanse, M. (2000). Whole small fish as a rich calcium source. *Brit J Nutr* **83**, 191–196.
- Laufenberg, G., Kunz, B. and Nystroem, M. (2003). Transformation of vegetable waste into value added products. *Bioresource Technol* **87**, 167–198.
- Lekang, O.-I., Bergheim, A. and Dalen, H. (2000). An integrated wastewater treatment system for land-based fish-farming. *Aquacult Engin* **22**, 199–211.
- Liao, P.H., Vizcarra, A.T., Chen, A. and Lo, K.V. (1995). A comparison of different bulking agents for the composting of fish offal. *Compost Sci Util* **3**(3), 80–86.
- Lie, O., Sandvin, A. and Waagbo, R. (1994). Transport of alpha-tocopherol in Atlantic salmon (*Salmo salar*) during vitellogenesis. *Fish Phys Bioch* **13**, 241–247.
- Lowry, O.H., Rosenbrough, N., Farr, A.L. and Randall, R.J. (1951). Protein measurements with the folin phenol reagent. *J Biol Chem* **193**, 265–275.
- Lundie, S. and Peters, G.M. (2005). Life cycle assessment of food waste management options. *J Cleaner Product* **13**, 275–286.
- Lupatsch, I., Katz, T. and Angel, D.L. (2003). Assessment of the removal efficiency of fish farm effluents by grey mullets: a nutritional approach. *Aquacult Res* **34**, 1367–1377.
- MacMillan, J.R., Huddleston, T., Woolley, M. and Fothergill, K. (2003). Best management practice development to minimize environmental impact from large flow-through trout farms. *Aquacult* **226**, 91–99.
- Martin, A.M. (1999). A low-energy process for the conversion of fisheries waste biomass. *Renewable Energy* **16**, 1102–1105.
- Martin, A.M. and Chintalapati, S.P. (1990). Composting of fish offal with peat and its use in the production of microbial biomass. In *Advances in fisheries technology and biotechnology for increased profitability* (M.N. Voigt and J.R. Botta, eds), pp. 387–394. Technomic, Lancaster.
- Martone, C.B., Perez Borla, O. and Sanchez, J.J. (2005). Fishery by-product as a nutrient source for bacteria and archaea growth media. *Bioresource Technol* **96**, 383–387.
- Midlen, A. and Redding, T. (1998). *Environmental management for aquaculture*, p. 223. Chapman & Hall, London.
- Miller, G.L. (1959). Use of dinitrosalicylic acid reagent for determination of reducing sugar. *Analyt Chem* **31**, 426–437.
- Miller, R. and Groninger, H.S. (1976). Functional properties of enzyme modified acylated fish protein derivatives. *J Food Sci* **41**, 268–272.
- Mohan, S., Gopalan, M. and Sreenarayanan, V.V. (1993). Fishmeal waste as an attractant for economically important flies of agricultural crops. *Bioresource Technol* **43**, 175–176.
- Montero, P. and Borderias, J. (1990). Gelification of collagenous material from muscle and skin of hake (*Merluccius merluccius* L.) and trout (*Salmo irideus* Gibb) according to variation in pH and the presence of NaCl in the medium. *Z Lebensm Unters Forsch* **191**, 11–15.

- Morimura, S., Nagata, H., Uemura, Y., Fahmi, A., Shigematsu, T. and Kida, K. (2002). Development of an effective process for utilisation of collagen from livestock and fish waste. *Process Biochem* **37**, 1403–1412.
- Morris, D.L. (1948). Quantitative determination of carbohydrates with Dreywood's Anthrone reagent. *Science* **107**, 254–255.
- Mshandete, A., Kivaisi, A., Rubindamayugi, M. and Mattiasson, B. (2004). Anaerobic batch co-digestion of sisal pulp and fish wastes. *Bioresource Technol* **95**, 19–24.
- Murray, C.K. and Gibson, D.M. (1972). An investigation of the methods of determining trimethylamine in fish muscle extracts by the formation of its picrate salts. *J Food Technol* **7**, 35–46.
- Myer, R.O., Brendemuhl, J.H. and Johnson, D.D. (1999). Evaluation of dehydrated restaurant food waste products as feedstuffs for finishing pigs. *J Anim Sci* **77**, 685–692.
- Nagai, T. and Suzuki, N. (2000). Isolation of collagen from fish waste material – skin, bone and fin. *Food Chem* **68**, 277–281.
- Navarro, A.F., Cegarra, J., Roig, A. and Bernal, P. (1990). Análisis de residuos urbanos agrícolas, ganaderos y forestales: relación materia orgánica-cardono orgánico. In *III Cong Internac de Química de la ANQUE. Residuos sólidos y líquidos: su mayor destino*, pp. 447–456. Fondo Editorial ANQUE, Madrid.
- Nelson, D.W. and Sommer, L.E. (1996). Total carbon, organic carbon and organic matter. In *SSSA Book Series: 5 Methods of Soil Analysis Part 3 Chemical Methods* (D.L. Sparks, ed.), pp. 983–1000. American Society of Agronomy, Inc., Madison.
- New, M. (1996). Responsible use of aquaculture feeds. *Aquacult Asia* **1**, 3–15.
- Nozaki, Y., Ichikawa, H. and Tabata, Y. (1991). Effect of amino acid on the state of water and ATPase activity accompanying dehydration of fish myofibrils. *Nippon Suisan Gakkaishi* **57**, 1531–1537.
- NRC (National Research Council) (1998). *Nutrient requirements of swine*, 10th revised edn, pp. 3–7, 45–57, 90, 115. National Academy Press, Washington, DC.
- Oceanographic Applications to Eutrophication in Regions of Restricted Exchange (OAERRE) (2001). *Oceanographic applications to eutrophication in regions of restricted exchange* (on-line). Available: <http://www.oaerre.napier.ac.uk>, accessed in January 2002.
- Ozawa, M., Satake, K. and Suzuki, R. (2003). Removal of aqueous chromium by fish bone waste originated hydroxyapatite. *J Mater Sci Lett* **22**, 513–514.
- Paniagua-Michel, J. and Garcia, O. (2003). Ex-situ bioremediation of shrimp culture effluent using constructed microbial mats. *Aquacult Engin* **28**, 131–139.
- Payraudeau, S. and van der Werf, H.M.G. (2005). Environmental impact assessment for a farming region: a review of methods. *Agricult Ecosyst Environ* **107**, 1–19.
- Pennington, R.J. and Sutherland, T.M. (1956). Ketone-body production from various substrates by sheep rumen epithelium. *Biochem J* **63**, 353–361.
- Perea, A., Ugalde, U., Rodriguez, I. and Serra, J.L. (1993). Preparation and characterisation of whey protein hydrolysates: application in industrial whey bioconversion processes. *Enzyme Microb Technol* **15**, 418–423.
- Persson, G. (1988). *Relationships between feed, productivity and pollution in the farming of large rainbow trout (Salmo gairdneri)*, p. 48. Swedish Environmental Protection Agency, Stockholm.

- Persson, G. (1991). Eutrophication resulting from Salmonid fish culture in fresh and salt waters: Scandinavian experiences. In *Nutritional Strategies and Aquaculture Waste* (C.B. Cowey and C.Y. Cho, eds), pp. 163–185.
- Pillay, T.V.R. (1991). *Aquaculture and the environment*, pp. 26–45. Blackwell Scientific, London.
- Quitain, A.T., Sato, N., Daimon, H. and Fujie, K. (2001). Production of valuable materials by hydrothermal treatment of shrimp shells. *Indust Engin Chem Res* **40**, 5885–5888.
- Read, P. and Fernandes, T. (2003). Management of environmental impacts of marine aquaculture in Europe. *Aquaculture* **226**, 139–163.
- Ronnberg, O., Adjers, K., Roukolahti, C. and Bondestam, M. (1992). Effects of fish farming on growth, epiphytes and nutrient content of *Fucus vesiculosus* L. in the Åland archipelago, northern Baltic Sea. *Aquat Bot* **42**, 109–120.
- Ruokolahiti, C. (1988). Effects of fish farming on growth and chlorophyll a content of *Cladophora*. *Mar Pollut Bull* **19**(4), 166–169.
- Ruttanapornvareesakul, Y., Ikeda, M., Hara, K., Osako, K., Kongpun, O. and Nozaki, Y. (2005). Effect of shrimp head protein hydrolysates on the state of water and denaturation of fish myofibrils during dehydration. *Fish Sci* **71**, 220–228.
- Ruttanapornvareesakul, Y., Ikeda, M., Hara K. *et al.* (2005). Concentration-dependent suppressive effect of shrimp head protein hydrolysate on dehydration-induced denaturation of lizardfish myofibrils. *Bioresource Technol* **97**, 762–769.
- Sachindra, N.M., Bhaskar, N. and Mahendrakar, N.S. (2006). Recovery of carotenoids from shrimp waste in organic solvents. *Waste Manage* **26**(10), 1092–1098.
- Sacton, J. (1986). *The seafood handbook: seafood business*, Seattle.
- Samuels, W.A., Fontenots, J.P., Allen, V.G. and Flick, G.J. (1992). Fermentation characteristics of ensiled seafood wastes and low-quality roughages. *Anim Feed Sci Technol* **38**, 305–317.
- Samuels, W.A., Fontenot, J.P., Allen, V.G. and Abazinge, M.D. (1991). Seafood processing wastes ensiled with straw: utilisation and intake by sheep. *J Anim Sci* **69**, 4983–4992.
- Sandberg, M. and Ahring, B.K. (1992). Anaerobic treatment of fishmeal process wastewater in a UASB reactor at high pH. *Appl Microbiol Biotechnol* **36**, 800–804.
- Sandel, E.B. (1950). *Calorimetric determinations of traces of metals*, p. 411. Interscience Pub., New York.
- Shahidi, F., Han, X.-Q. and Synowiecki, J. (1995). Production and characteristics of protein hydrolysates from capelin (*Mallotus villosus*). *Food Chem* **53**, 285–293.
- Shahidi, F., Metusalach, G. and Brown, J.A. (1998). Carotenoid pigments in seafoods and aquaculture. *CRC Crit Rev Food Sci* **38**, 1–67.
- Shih, I.-L., Chen, L.-G., Yu, T.-S., Chang, W.-T. and Wang, S.-L. (2003). Microbial reclamation of fish processing wastes for the production of fish sauce. *Enzyme Microb Technol* **33**, 154–162.
- Silvert, W. (1992). Assessing environmental impacts of finfish aquaculture in marine waters. *Aquaculture* **107**, 67–79.
- Skrede, G. and Storebakken, T. (1986). Characteristics of colour in raw, baked and smoked wild and pen-reared Atlantic salmon. *J Food Sci* **51**, 804–808.
- Soto, M., Veiga, M.C., Méndez, R. and Lema, J.M. (1989). Semi-micro COD determination method for high saline wastewater. *Environ Technol Lett* **10**, 541–548.

- Stepnowski, P., Olafsson, G., Helgason, H. and Jastor, B. (2004). Recovery of astaxanthin from seafood wastewater utilizing fish scales waste. *Chemosphere* **54**, 413–417.
- Stewart, N.T., Boardman, G.D. and Helfrich, L.A. (2006). Treatment of rainbow trout (*Oncorhynchus mykiss*) raceway effluent using baffled sedimentation and artificial substrates. *Aquacult Engin* (in press).
- Suzuki, T. (1981). *Fish and krill protein: processing technology*. Applied Science, London.
- Tavares, J.F.P., Baptista, J.A.B. and Marcone, M.F. (1997). Milk-coagulating enzymes of tuna fish waste as a rennet substitute. *Int J Food Sci Nutrit* **48**, 169–176.
- Thassitou, P.K. and Arvanitoyannis, I.S. (2001). Bioremediation: a novel approach to food waste management. *Trends Food Sci Technol* **12**, 185–196.
- Troell, M., Halling, C., Nilsson, A., Buschmann, A.H., Kautsky, N. and Kautsky, L. (1997). Integrated marine cultivation of *Gracilaria chilensis* (Gracilariales, Rhodophyta) and salmon cages for reduced environmental impact and increased economic output. *Aquaculture* **156**, 45–61.
- Twarowska, J.G., Westerman, P.W. and Losordo, T.M. (1997). Water treatment and waste characterisation evaluation of an intensive recirculating fish production system. *Aquacult Engin* **16**, 133–147.
- Undeland, I., Harrod, M. and Lingnert, H. (1998). Comparison between methods using low-toxicity solvents for the extraction of lipids from herring (*Clupea harengus*). *Food Chem* **61**, 355–365.
- Uresti, R.M., Tellez-Luis, S.J., Ramirez, J.A. and Vazquez, M. (2001). Use of dairy proteins and microbial transglutaminase to obtain low-salt products from filleting waste from silver carp (*Hypophthalmichthys molitrix*). *Process Biochem* **36**, 809–812.
- Van Biesen, G. and Parrish, C.C. (2005). Long-chain monounsaturated fatty acids as biomarkers for the dispersal of organic waste from a fish enclosure. *Marine Environ Res* **60**, 375–388.
- Van Soest, P.J. (1963). Use of detergents in the analysis of fibrous feeds: II. A rapid method for the determination of fiber and lignin. *J Assoc Off Agric Chem* **46**, 829–835.
- Van Soest, P.J. and Wine, R.H. (1967). Use of detergents in the analysis of fibrous feeds: IV. The determination of plant cell wall constituents. *J Assoc Off Anal Chem* **50**, 50–55.
- Vidotti, R.M., Viegas, E.M.M., Dalton, V. and Carneiro, D.J. (2003). Amino acid composition of processed fish silage using different raw materials. *Anim Feed Sci Technol* **105**, 199–204.
- Webb, N.B., Ivey, F.J. and Craig, H.B. (1970). The measurement of emulsifying capacity by electric resistance. *J Food Sci* **35**, 501–504.
- Westendorf, M.L. (2000). Food waste as animal feed: an introduction. In *Food waste to animal feed* (M.L. Westendorf, ed.), pp. 3–16, 69–90. Iowa State University Press, Ames.
- Westendorf, M.L., Dong, Z.C. and Schoknecht, P.A. (1998). Recycled cafeteria food waste as a feed for swine: nutrient content digestibility, growth, and meat quality. *J Anim Sci* **76**, 2976–2983.
- Wu, R., Lam, K., MacKay, D., Lau, T. and Yam, V. (1994). Impact of marine fish farming on water quality and bottom sediment: a case study in the sub tropical environment. *Marine Environ Res* **38**, 115–145.

- Wu, R.S.S. (1995). The environmental impact of marine fish culture: towards a sustainable future. *Mar Pollut Bull* **31**(4–12), 159–166.
- Yamamoto, M., Saleh, F., Ohtsuka, A. and Hayashi, K. (2005). New fermentation technique to process fish waste. *Anim Sci J* **76**, 245–248.
- Yatsumatsu, K., Sawada, K. and Moritaka, S. (1972). Whipping and emulsifying properties of soybean products. *Agricult Biol Chem* **36**(5), 719–727.
- Yoshida, H., Takahashi, Y. and Terashima, M. (2000). A simplified reaction model for production of oil, amino acids, and organic acids from fish meat by hydrolysis under sub-critical and supercritical conditions. *J Chem Engin Japan* **4**, 441–448.
- Yoshida, H., Terashima, M. and Takahashi, Y. (1999). Production of organic acids and amino acids from fish meat by sub-critical water hydrolysis. *Dept Chem Engin* **15**, 1090–1094.
- Zhang, N., Yamashita, Y. and Nozaki, Y. (2002). Effect of protein hydrolysate from Antarctic krill meat on the state of water and denaturation by dehydration of lizard fish myofibrils. *Fish Sci* **68**, 672–679.

Electronic sources

- http://www.agrifood-forum.net/publications/guide/f_chp2.pdf (accessed 2006, July, 16)
- <http://vefur.rf.is/TAFT2003/PDF/Reddington.pdf#search=%22Anaerobic%20digestion%20of%20fish%20waste-A%20novel%20solution%20to%20the%20problem%3F%22> (accessed 2006, August, 1)
- http://www.unep.or.jp/Ietc/Publications/spc/Solid_Waste_Management/Vol_I/15-Chapter9.pdf#search=%22food%20waste%20hydrolysis%20advantages%22 (accessed 2006, August, 15)
- http://www.dayton-knight.com/publications/staff%20papers/Emerging_Processes_in_Biosolids_Treatment_2003.pdf (accessed 2006, August, 15)
- <http://www.iupac.org/publications/pac/2001/pdf/7307x1163.pdf#search=%22bioremediation%20advantages%22> (accessed 2006, August, 17)
- http://www.yorku.ca/bunchmj/ICEH/proceedings/Sasikumar_CS_ICEH_papers_465to469.pdf#search=%22bioremediation%20%20disadvantages%22 (accessed 2006, August, 17)
- http://library.thinkquest.org/03oct/01840/New%20Page_5.htm (accessed 2006, August, 17)
- <http://www.lenntech.com/Pre-fermer.htm> (accessed 2006, August, 17)
- http://www.achema.de/data/achema_/congress/1713.pdf#search=%22anaerobic%20treatment%20advantages%22 (accessed 2006, August, 22)
- <http://www.nps.gov/dsc/dsgncnstr/gpsd/ch9.html> (accessed 2006, August, 22)
- <http://greenbusinesscentre.com/images/Photos/Hig48.pdf#search=%22anaerobic%20treatment%20advantages%22> (accessed 2006, August, 22)
- <http://www.wvu.edu/~agexten/aquaculture/waste02.pdf#search=%22Best%20management%20practices%20to%20reduce%20aquaculture%20waste%22> (accessed 2006, August, 28)
- http://www.unep.or.jp/Ietc/Publications/spc/Solid_Waste_Management/Vol_I/15-Chapter9.pdf#search=%22food%20waste%20hydrolysis%20advantages%22 (accessed 2006, August, 28)

- <http://www.oas.org/dsd/publications/Unit/oea59e/ch24.htm> (accessed 2006, August, 28)
- <http://www.fao.org/DOCREP/003/V9922E/V9922E05.htm> (accessed 2006, August, 28)
- http://www.copa.co.uk/products_detail.asp?wastewaterId=837 (accessed 2006, August, 30)
- http://www.wmrc.uiuc.edu/main_sections/info_services/library_docs/manuals/finishing/insing.htm (accessed 2006, August, 31)
- http://www.cals.ncsu.edu/waste_mgt/natlcenter/modules/powerpoint5.pdf (accessed 2006, August, 31)
- <http://www.bono.it/prodotti/prodotto.asp?prodpassata=cppprodba&unit=ba&cmp=ba> (accessed 2006, August, 31)
- <http://www.frtr.gov/matrix2/section4/4-50.html> (accessed 2006, August, 31)
- <http://www.earthprint.com/unep/download/2481.pdf> (accessed 2006, April, 10)
- http://www.fao.org/documents/show_cdr.asp?url_file=/DOCREP/003/X9199E/X9199E00.HTM (accessed 2006, April, 10)
- http://www.agrifood-forum.net/publications/guide/f_chap4.pdf (accessed 2006, April, 25)
- http://www.gpavlineris.com/id29_m.htm (accessed 2006, May, 1)
- <http://www.epa.gov/ttn/chief/ap42/ch09/final/c9s13-1.pdf> (accessed 2006, May, 1)
- http://www.agrifood-forum.net/publications/guide/f_chp3.pdf (accessed 2006, May, 18)
- http://ift.confex.com/ift/2001/techprogram/paper_6188.htm (accessed 2006, September, 27)

This page intentionally left blank

Food Packaging Waste Treatment

PART

6

15 Waste Management in Food Packaging Industries

941

This page intentionally left blank

Waste Management in Food Packaging Industries

Ioannis S. Arvanitoyannis

Introduction.....	941
Glass.....	950
Aluminum.....	958
Paper/carton.....	975
Polymers.....	980

Introduction

Food packaging material is expected to provide optimum protective properties so that the product it encloses remains in satisfactory condition for its anticipated shelf-life. The packaging technique, in conjunction with the choice of a packaging material endowed with appropriate gas and water barrier properties, aims to prevent destruction of food by microbial or insect attack. Packaging, and food packaging in particular, has been very eloquently described as 'a complex, dynamic, scientific, artistic and controversial segment of business' (Paine and Paine, 1992). The veracity of this definition can be easily certified since packaging is an exceptionally complicated process in which many company departments interact; it is 'dynamic' because of its continuously changing character and 'scientific' since further improvement of packaging is heavily dependent on scientific advances and innovations; of course, the scientific contribution is more than necessary for making the product more 'appealing' to the consumer (Robertson, 1993). The increased consumer demand for high quality, long-shelf-life, ready-to-eat foods has initiated the development of mildly preserved products that keep their natural and fresh appearance as long as possible (Baldwin *et al.*, 1995; Guilbert *et al.*, 1996). Edible and biodegradable polymer films offer alternative packaging options with advantages over the synthetic 'recalcitrant' packaging polymers because they do not contribute to environmental pollution (Arvanitoyannis *et al.*, 1996; Krochta *et al.*, 1997).

Although edible films are not meant to replace synthetic packaging films entirely, they do have the potential to reduce substantially the environmental burden due to food packaging and to limit moisture, aroma and lipid migration between food components (Krochta *et al.*, 1994, 1997). The potential of polysaccharides and proteins as edible films has long been recognized (Guilbert *et al.*, 1989, 1995; Genadios *et al.*, 1990, 1993; El Ghaouth *et al.*, 1991; Wong *et al.*, 1992; Lourdin *et al.*, 1995) but, apart from some very special applications (Kinsella, 1984; Park *et al.*, 1993, 1994), polysaccharide-and/or protein-based edible films have not yet found extensive applications in the food industry (Kester and Fennema, 1986).

One of the major targets of society is to satisfy its population's demands for goods of every kind. However, this would be impossible without suitable packaging, particularly since 50% of all packaging is employed for foods and another 20% for the rest of household daily requirements (Eschke, 1990). Solid waste arises from process operations, used or scrap packaging materials and even the saleable products themselves when they are finally discarded. Under the European Union Framework Directive on waste (91/156/EEC), waste is defined as any substance or object which the holder discards or intends to discard, thus waste, in other words, means: 'Any substance or object which falls into one of sixteen categories in Annex 1 of the directive, which the holder must discard, intends to discard or requires to discard, which is an all encompassing definition'. However, according to the Environmental Protection Act, 'Waste is any substance which constitutes scrap material or an effluent or other unwanted surplus substance or article which requires to be disposed of as being broken, worn out, contaminated or otherwise spoiled' (Clarke *et al.*, 1999; Read, 1999). The role of packaging is to protect food from its environment. Currently, almost all purchased products are in packaged form. The materials and designs employed for each packaging operation depend on the product itself reflecting the role that it was designed to perform. Packaging is used for meeting the following requirements (Waite, 1995; Krochta *et al.*, 1997):

- 1 Protection of product from mechanical damage, contamination and deterioration
- 2 Promotion and advertisement of the product
- 3 Information disclosure to the consumer regarding the content, composition and instructions for safe use
- 4 Improvement of distribution and reduction of storage and transportation costs
- 5 Convenience
- 6 Safety function and prevention of inappropriate use.

Packaging, despite the convenience it provides to the consumer, is subject to many debates concerning environmental issues. It has been considered a constant source of environmental waste due to its volume, since it occupies close to two-thirds of trash can volume (Waite, 1995; Plinke and Kaempf, 1995; Krochta *et al.*, 1997). Furthermore, the constant increase in the use of plastics makes their disposal a major environmental issue. Packaging represents approximately 30% weight of municipal solid waste (MSW), but appears much more significant because it occupies close to

65% of waste volume due to its bulkiness (Krochta *et al.*, 1997). Sustainable development is the driving force for acting more responsibly to protect our world for future generations. It encompasses a combination of environmental, social and economic aspects (<http://www.apme.org/environment/htm/sustainable.future.pdf>). Most consumers would like to have plastic packaging replaced with some other form of recyclable packaging, such as glass or paper, if possible. However, were plastic packaging to be replaced, a scrupulous data analysis revealed that there would be a: 100% increase in energy consumption; 400% increase in raw material consumption; 150% increase in waste volume; 100% increase in packaging cost. The results of a 1992 study performed by Gesellschaft für Verpackungsmarktforschung (GVM) in Germany revealed that if plastic were to be replaced by other packaging materials, packaging tonnage would rise by around 4 million tons, from 1427 to 5577 million tons. Consequently, the volume of waste collected in trash barrels would increase from 50.4 billion to 130 billion liters and the energy demand would reach higher than double figures (Campbell, 1994). It is frequently stated that plastic waste is the major contributor to domestic waste. Plastic packaging, however, is 13% of the 30% weight packaging share of MSW, thus representing only around 4–5% weight of MSW (Pearson, 1996; Krochta *et al.*, 1997). It has been estimated that 9.4 million tons of plastics are used in Europe for packaging purposes, representing 39% of the total plastic utilized (Castle, 1994). Plastic packaging has several advantages to offer to consumers; it is safe, strong, lightweight, easily processed and stored and economical. Therefore, numerous studies were conducted on safe plastic waste management in order to minimize the undesirable environmental impacts of the utilized plastic packaging material (Krochta *et al.*, 1997). The predominant method of waste disposal in most countries all over the world (except for the Netherlands) has been and remains landfill. The main approaches to waste management are, by priority, as follows:

- 1 Prevention and reduction at source, re-use
- 2 Degradable packaging
- 3 Recycling (mechanical, chemical, feedstock)
- 4 Combustion for energy recovery
- 5 Combustion for volume reduction
- 6 Landfill (Thurgood, 1995; Mertzani, 1997; Read *et al.*, 1997; Krishna *et al.*, 1998; Read, 1999b).

Although prevention and source reduction is considered to be the best waste management option, this approach is anticipated only partially to solve the problem (Tsimilis and Hadjimanolis, 1995). Current demand for energy and virgin resources, many of which are non-renewable, cannot continue without fostering ever greater environmental and economic degradation. Law makers and producers must, instead, recognize the necessity of a new policy for the new century – a policy based on environmentally and economically sustainable use of materials, or ‘materials efficiency’. Recycle and re-use, which usually use materials, energy and water more efficiently than virgin material industries and produce less pollution, are essential elements of such a material efficient policy (<http://www.grn.org>; <http://apme.org/environment/htm/0.4.htm>, Karakasidis, 1997).

A new market-incentive (MI) system was launched to recycle waste packaging containers in Taiwan. Since most used packaging containers have no or insufficient market value, the government imposes a combined product charge and subsidy policy to provide enough economic incentive for recycling various kinds of packaging containers, such as iron, aluminum, paper, glass and plastic. Empirical results show that the new MI approach has stimulated and established the recycling market for waste packaging containers. The new recycling system has provided 18 356 employment opportunities and generated NT\$ 6.97 billion in real-production value and NT\$ 3.18 billion in real GDP during the 1998 survey year. Cost-effectiveness analysis constitutes the theoretical foundation of the new scheme, whereas data used to compute the empirical product charge are from two sources: marketing surveys of internal conventional costs of solid-waste collection, disposal and recycling in Taiwan and benefit transfer of external environmental costs in the USA. The new recycling policy designed by Bor and his coworkers (2004) provided a reasonable solution for solid-waste management in a country with limited land resources such as Taiwan.

A proper analysis (an evaluation) of the environmental load of consumption is important in the context of sustainable development. Nowadays, different methods are used to calculate the environmental load of household consumption, mainly in energy and or greenhouse gas emission terms. These methods are all based on input-output energy analysis, but use different data sources and produce different results. Three methods used to calculate the total energy requirements of households have been discerned and described and the main result produced with these methods discussed. All three methods were applied to the Netherlands in order to compare differences and similarities in the results. It was found that the total energy requirement calculated with all three methods was almost the same, with differences less than 4%, however, each method provides results at a different level. Basic energy input-output analysis generates total requirements and requirements per consumption category and is therefore suitable for describing and explaining the effect of household consumption. The hybrid method, combining energy input-output analysis with process analysis, generates requirements per consumption item and therefore offers opportunities to search for options of change of household consumption patterns to more sustainable consumption. Reviewing the methods applied to calculate household energy requirements three different types of methods were distinguished:

- 1 input-output energy analysis, based on national accounts (IO-EA-basic)
- 2 input-output energy analysis combined with household expenditure data (IO-EA-expenditure)
- 3 hybrid energy analysis, input-output analysis combined with process analysis (IO-EA-process) and data and operations needed for these three methods are shown in Figure 15.1.

The life cycle of a product as used in the IO-EA-process method is given in Figure 15.2 (Kok *et al.*, 2006). The major difference between the IO-EA-expenditure method and the other two methods is found for agriculture, where the energy requirement with the

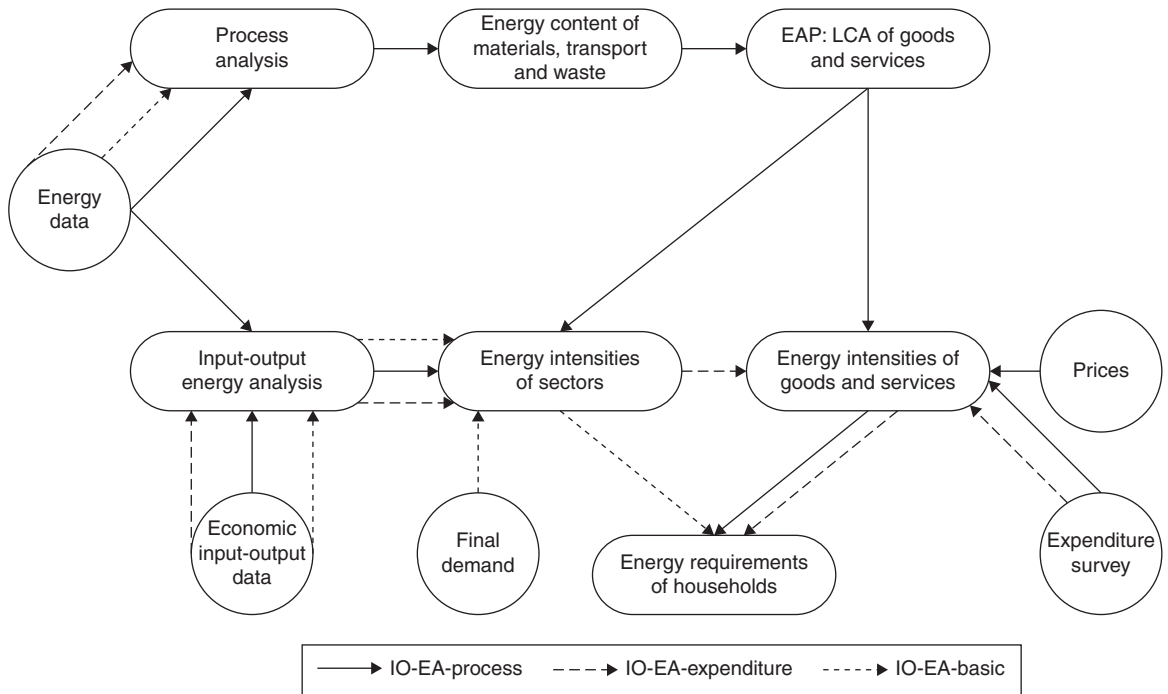

Figure 15.1 Data and operations needed for the three different energy analysis methods (adapted from Kok *et al.*, 2006)

IO-EA-expenditure method is considerably higher due to the high average energy intensity for horticulture.

Diaz and Warith (2006) developed a Waste Analysis Software Tool for Environmental Decisions (WASTED) model. This model provides a comprehensive view of the environmental impacts of municipal solid waste management systems. The model consists of a number of separate submodels that describe a typical waste management process: waste collection, material recovery, composting, energy recovery from waste and landfilling. These submodels are combined to represent a complete waste management system. Aluminum and steel are the only metal components in MSW considered to be fit for recycling in the WASTED model. Most of the aluminum in the waste stream comes from beverage cans. Aluminum is one of the most attractive materials for recovery from the waste stream. This is because aluminum recycling consumes far less energy (11.7 GJ/ton) than the smelting of aluminum ore (140 GJ/ton). The recycling data for metals are given in Table 15.1.

The glass that is recovered is found in food and beverage containers. This fraction includes both colored and clear glass bottles. However, this is an energy intensive process that takes place at 1800 K (Wang and Pereira, 1980), so the energy required to recycle glass is 9.23 GJ/ton compared to 14.1 GJ/ton for virgin raw materials (Haight,

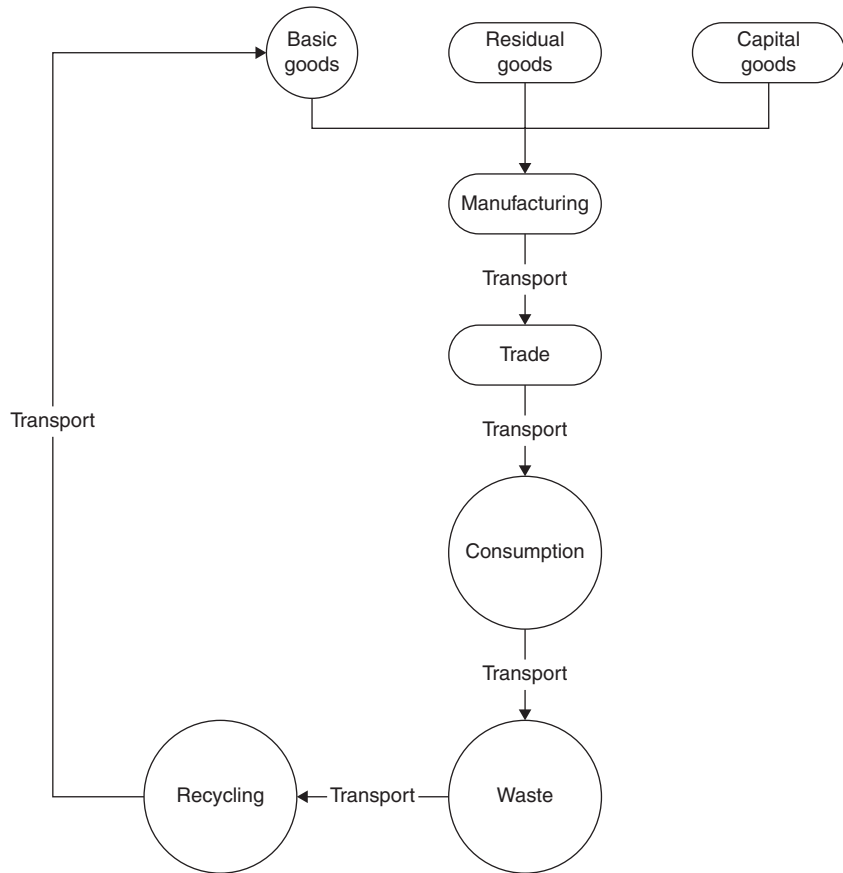

Figure 15.2 Life cycle of a product as used in the IO-EA-process method (adapted from Kok *et al.*, 2006)

2004). Glass can also be recycled in a closed loop. The recycling data for glass are given in Table 15.2.

Newspaper is typically the largest fraction of paper recycled (EPA, 2002). Fine paper comprised paper used for printing and photocopying. Cardboard is the typical material used for packaging. It includes both the smooth and corrugated fractions of this material. Mixed paper describes unsorted paper wastes. The recycling data for paper products are summarized in Table 15.3.

Although the technology to recycle most plastics exists, the sorting and preparation processes are complex. Therefore, most localities do not recycle all plastics. Currently, plastic is classified into seven categories, categorized by name and number:

- 1 polyethylene terephthalate (PET or PETE)
- 2 high-density polyethylene (HDPE)
- 3 polyvinyl chloride (PVC)
- 4 low-density polyethylene (LDPE)

Table 15.1 Recycling data for metals (kg/ton)

Parameter	Aluminum		Ferrous metal	
	Virgin	Recycled	Virgin	Recycled
Energy (Gj)	140.00	11.70	25.20	9.43
<i>Air emissions</i>				
CO ₂	2900.00	4.36	1820.00	595.00
PFC (CO ₂ eq.)	2226.00	0.00	0.00	0.00
CH ₄	6.53	2.71	0.0097	1.29
NO _x	17.30	0.62	2.76	1.77
VOCs	24.50	0.30	0.23	0.02
SO _x	47.60	2.88	5.11	2.98
PM	10.00	0.00	1.31	7.22
Pb	1.93×10^{-3}	0.38	7.60×10^{-4}	6.59×10^{-4}
Hg	n/a	n/a	n/a	n/a
Cd	n/a	4.37×10^{-5}	n/a	n/a
HCl	0.81	5.81×10^{-2}	8.57×10^{-2}	0.10
<i>Water emissions</i>				
Pb water	1.47×10^{-7}	0.00	2.92×10^{-2}	2.90×10^{-2}
Hg water	0.00	0.00	n/a	n/a
Cd water	0.24	0.06	9.75×10^{-5}	9.38×10^{-5}
TCDD Eq W	1.20×10^{-6}	4.42×10^{-8}	n/a	n/a

Adapted from Haight, 2004

Table 15.2 Recycling data for glass (kg/ton)

Parameter	Glass	
	Virgin	Recycled
Energy (Gj)	14.10	9.23
<i>Air emissions</i>		
CO ₂	632.00	278.00
PFC (CO ₂ eq.)	0.00	0.00
CH ₄	1.11	0.83
NO _x	2.73	1.69
VOCs	0.24	0.17
SO _x	4.37	3.11
PM	0.89	0.43
Pb	5.01×10^{-6}	1.15×10^{-6}
Hg	1.30×10^{-6}	3.00×10^{-7}
Cd	1.35×10^{-5}	2.95×10^{-6}
HCl	5.96×10^{-2}	0.98
<i>Water emissions</i>		
Pb water	3.60×10^{-8}	1.90×10^{-8}
Hg water	2.55×10^{-8}	1.95×10^{-8}
Cd water	2.20×10^{-4}	2.55×10^{-4}
TCDD Eq. W	n/a	n/a
BOD	6.9×10^{-3}	5.1×10^{-3}

Adapted from Haight, 2004

Table 15.3 Recycling data for paper products (kg/ton)

Parameter	Newspaper		Fine paper		Corrugated board		Mixed paper	
	Virgin	Recycled	Virgin	Recycled	Virgin	Recycled	Virgin	Recycled
Energy (GJ)	46.43	25.57	43.05	23.40	29.23	13.64	36.85	26.21
<i>Air emissions</i>								
CO ₂	2400.00	1385.00	1100.00	1507.00	896.00	1019.00	1304.00	1752.00
PFC (CO ₂ eq.)	0.00	-3060.00	0.00	-4580.00	0.00	-4580.00	0.00	-4580.00
CH ₄	0.03	0.02	0.02	0.02	0.01	0.01	0.02	0.01
NO _x	10.40	5.26	8.74	5.38	6.25	5.56	7.94	5.44
VOCs	11.20	7.19	8.27	18.47	3.87	35.40	6.86	23.89
SO _x	16.30	9.40	12.88	9.80	7.74	10.40	11.23	9.99
PM	4.63	2.80	4.81	3.10	5.07	3.56	4.89	3.25
Pb	4.52 × 10 ⁻⁴	2.63 × 10 ⁻⁴	3.52 × 10 ⁻⁴	2.67 × 10 ⁻⁴	2.03 × 10 ⁻⁴	2.73 × 10 ⁻⁴	3.05 × 10 ⁻⁴	2.69 × 10 ⁻⁶
Hg	n/a	n/a	n/a	n/a	n/a	n/a	n/a	n/a
Cd	n/a	n/a	n/a	n/a	n/a	n/a	n/a	n/a
HCl	n/a	3.87 × 10 ⁻⁶	3.57 × 10 ⁻⁶	4.51 × 10 ⁻⁶	8.93 × 10 ⁻⁶	5.46 × 10 ⁻⁶	5.29 × 10 ⁻⁶	4.81 × 10 ⁻⁶
<i>Water emissions</i>								
Pb water	1.63 × 10 ⁻⁷	6.35 × 10 ⁻⁸	1.46 × 10 ⁻⁷	6.59 × 10 ⁻⁸	1.20 × 10 ⁻⁷	6.95 × 10 ⁻⁸	1.38 × 10 ⁻⁷	6.71 × 10 ⁻⁸
Hg water	3.82 × 10 ⁻⁸	2.33 × 10 ⁻⁸	2.69 × 10 ⁻⁸	1.40 × 10 ⁻⁸	9.92 × 10 ⁻⁹	0.00	2.15 × 10 ⁻⁸	9.51 × 10 ⁻⁹
Cd water	0.00	0.00	0.00	0.00	0.00	0.00	0.00	0.00
BOD	3.51	3.09	2.71	3.29	1.52	3.58	2.33	3.38

Adapted from EPA, 2002; Haight, 2004

Table 15.4 Recycling parameters for plastics (kg/ton)

Parameter	PET		PE		PP		PS		PVC	
	Virgin	Recycled	Virgin	Recycled	Virgin	Recycled	Virgin	Recycled	Virgin	Recycled
Energy (Gj)	107.15	46.07	79.76	19.94	76.42	19.87	84.8	11.63	59.8	9.13
<i>Air emissions</i>										
CO ₂	2363	163	2400	163	2100	942	2200	942	2000	942
PFC (CO ₂ eq.)	25	0.016	28	0.016	28	0.016	24	0.016	22	0.016
CH ₄	9.5	0.081	6.5	0.081	6.4	0.081	6.9	0.081	6.3	0.081
NO _x	7.2	6.95	7.8	6.95	7.7	6.95	5.9	6.95	5.8	6.95
VOCs	14	n/a	4.9	n/a	5.4	n/a	5.2	n/a	5.3	n/a
SO _x	4.6	n/a	1.5	n/a	1.7	n/a	2.4	n/a	1.4	n/a
PM	n/a	n/a	n/a	n/a	n/a	n/a	n/a	n/a	n/a	n/a
Pb	n/a	n/a	n/a	n/a	n/a	n/a	n/a	n/a	n/a	n/a
Hg	n/a	n/a	n/a	n/a	n/a	n/a	n/a	n/a	n/a	n/a
Cd	0.058	n/a	0.011	n/a	0.014	n/a	0.014	n/a	0.016	n/a
HCl	n/a	n/a	n/a	n/a	n/a	n/a	n/a	n/a	n/a	n/a

Adapted from Molgaard, 1995; Eulalio *et al.*, 2000; EPA, 2002; Haight, 2004

- 5 polypropylene (PP)
- 6 polystyrene (PS)
- 7 other plastics (Other).

Recycling parameters for plastics are given in Table 15.4.

Composting has several environmental advantages over landfilling. In the first place, when done properly composting generates no methane (CH₄). This gas is produced by anaerobic degradation of wastes (for example, in a landfill) and has 21 times the greenhouse potential of CO₂ (IPPC, 1996). Additionally, mature compost can be used as a soil conditioner and does not generate long-term environmental concerns. Finally, the aerobic degradation of organic compounds results in the 'storage' of a small amount of carbon that is not degraded to CO₂, but is transformed into slowly decomposable components (EPA, 2002). Modern landfills are engineered facilities that are designed to stabilize the solid wastes and minimize hazards to the public. Although the ideal case is that 100% of every good produced is reintroduced to the production cycle, this is thermodynamically impossible. Therefore, landfills are necessary even when waste diversion rates are high. WASTED allows the users to select from four different kinds of landfills:

- 1 sanitary landfill
- 2 bioreactor landfill
- 3 unlined landfill with leachate collection
- 4 unlined landfill with no leachate collection.

The results for this model are comparable to other publicly available models, such as WARM or IWM. These differences are due to the different system boundaries in the

models and in the different parameters used to describe the waste management operations. Since WASTED allows the users to fine-tune the input parameters, it can be adjusted better to reflect the specific conditions in a case study.

Glass

Introduction

The discovery of glass dates back to the Phoenicians more than 5000 years ago, although it is believed that glass bottles were invented by the Egyptians with the method of hand blowing 1000 years later. However, during the last hundred years, mechanized glass blowing techniques have revolutionized the production of glass containers, allowing bottles to be produced quickly and cheaply (Waite, 1995; Vogas, 1995; Pearson, 1996; Read, 1999b). Glass is a melt that has been solidified without being subject to crystallization and reacts only with fluoride and hydrofluoric acid. Practically, there are no limits in glass quantity that can be produced, since 80% of the earth's surface consists of sand, soda and limestone, the basic glass constituents. Small quantities of other substances are added to impart the desirable properties to the final product.

New glass is traditionally produced by melting sand, soda and limestone at temperatures of between 1200 and 1500°C. Then the temperature decreases and through a metering unit the melted glass is removed from the furnace and is driven to the shaping/forming machine to receive the appropriate form and shape. Glass can be molded in different types, shapes and colors. The common colorings are usually brown, green and clear. Clear glass comprises over 50% of the international market while colored glass the other 50%, thus satisfying traditional consumer demands. For example, brown glass is used to offer satisfactory protection from light and is employed for products like fruit juices, medicines and alcoholic drinks. Small fragments of broken colored and clear glass can be added in the production of new colored glass containers, while in the case of clear glass production only clear glass cullet can be used (White *et al.*, 1995; Dascalopoulos *et al.*, 1998).

Glass packaging, though fragile and heavy compared to other packaging materials, is endowed with properties that make its total replacement by lighter materials a very difficult task. Glass is also an environmentally friendly material, since it is inactive and totally degradable. When it is exposed to the environment it breaks into small fragments of silicon and sand, two of the most common materials in our planet. Even though glass is a degradable material, its re-use and recycling improve considerably its environmental performance. Usage of recycled glass as cullet for the production of new glass containers saves energy, raw material and reduces glass manufacturing costs. Container glass is the only glass item being recycled in large quantities at the present time. Window panes, light bulbs, mirrors, ceramic dishes and pots, glassware, crystal, ovenware and fiberglass are some representative glass items that cannot be recycled with container glass and are considered contaminants in container glass recycling (Mondorf and Jensen, 1995; Nijkerk, 1995; Gilmore and Hayes, 1996; Hynes and Jonson, 1997).

Energy is conserved because cullet melts down at a lower temperature than that required for processing the raw materials for glass production. This practice does not only reduce energy cost, but extends furnace life as well. Depending on the amount of cullet used, furnace life can be extended by 15–20%. The conservation of energy, in turn, contributes to natural resources preservation. Generally, by employing recycled glass, 25% less energy is required and a reduction of 80% and 50% in raw materials and water quantity required is achieved, respectively (Nguyen *et al.*, 1995; <http://www.raymond.com/rates97htm>, <http://www.epa.gov/epaoswer/non-hw/muncpl/factbook/internet/mswf>; Cook, 1995).

International situation

In 1996, glass fragments accounted for 56% of the total material in the glass industry and 71% for green glass. The constantly increasing usage of glass waste in the glass manufacturing industry over recent years resulted in decreases in soda consumption and energy of 67% and 35%, respectively. Glass is the second most important in weight packaging material, since it represents 8% by weight of the municipal solid waste (MSW) and 2% by volume. Therefore, reduction in glass at waste streams could be of a substantial aid in achieving targets that are typically measured as percentages of total waste weight. In waste streams, glass packaging represents around 98% of total glass waste, while the other 2% consists of light bulbs and window panes. Although industry mainly recycles glass packaging, other glass waste is also recycled at a smaller percentage (4%) and used primarily for the production of construction materials (<http://www.britglass.co.uk/recycling/glassrec.html>, <http://www.britglass.co.uk/recycling/stats97.html>; Barlow, 1994). The three most important practices employed by European and other nations are presented in Table 15.5. Germany, Switzerland and Holland are the leading countries in glass recycling worldwide with recycling rates of 81–89%. Satisfactory recycling rates in other European countries (around 50%), such as France, Italy, Austria, Belgium, Norway and Denmark have also been achieved. In general, in 1996 Europe recycled around 50% of the produced glass, Australia 44%, the USA 32% and Japan 60%. According to EPA (United States Environmental Protection Agency), glass recycling rates in the USA are expected to reach 36% by the end of the year 2000 (Table 15.6).

Although Holland has a very high recycling rate for glass, in 1996, there was a surplus of mixed glass which was not separated into the three known qualities: clear, green, brown. The problem that arose could be solved with the introduction of compartmentalized bottle banks for color sorted glass collection, like in Germany, but the high expenditure of three colored sorted banks prevented their use. Therefore, in Holland, the first complete glass separation factory started operating, handling about 150 000 ton/year, by making use of a laser separation system. In Germany, the recycling system requires that consumers use six different waste bins at their houses that lead to the collection of undesirable materials as well. In Greece, 125 000 tonnes are produced out of which only 25 000 are recycled, while ambitious targets have been set to reach 50 000 tonnes, aiming at a reduction of municipal solid wastes volume by 100 000 m³.

Table 15.5 Treatment routes employed by European and other nations (%MSW)

Nation	Recycled and composted	Incineration	Landfill
Switzerland	29	59	12
Denmark	23	48	29
Sweden	19	47	34
France	13	42	45
The Netherlands	19	35	45
Germany	18	36	46
Austria	24	11	65
Norway	11	22	67
Finland	15	2	83
Belgium	3	54	43
Italy	10	16	74
Spain	30	6	65
Ireland	3	0	97
Luxembourg	3	75	22
Portugal	15	0	85
UK	2	10	88
Canada	12	8	80
USA	17	16	67
Greece	0	0	100

Adapted from Onusselt, 1997

Table 15.6 Glass recycling rates around the world (%)

Country	1991	1993	1994	1995	1996	1997
Germany	55	71	75	82	85	89
France		46	48	50	50	
Italy		52	54		53	
UK	21	29	28	27	26	26
Spain		29	31		35	
Holland		73	77	80	81	
Belgium		55	67	67		
Austria		68	76			
Denmark		64	67			
Sweden		54	56		72	
Portugal		29	32			
Greece		27	29	29		
Norway			72		75	
Finland			50			
Ireland		29	31			
Switzerland		78	84		89	
Australia					89	
USA	25				33	
Japan					60	

Adapted from Arvanitoyannis and Bosnea, 2001

Glass recycling process

As soon as the glass waste is delivered to glass recycling plants, its separation according to color starts while metal rings and bottle tops are being removed. The glass waste is crushed into small particles and the mixture is called 'cullet'. The recycling process of glass depends entirely on the type of glass that will be produced (Stotzel, 1997). There are some basic rules to be followed during glass recycling, so glass should be free from metal tops, ceramics and stones and be sorted according to color. There should be a thorough removal of foreign materials, otherwise the produced glass might be defective. The quantity of ceramics left on the cullet should not be more than 25 g per tonne, while the metal particles should be less than 5 g per tonne. Therefore, the basic container glass recycling process steps are:

- 1 initial rinsing, cap and lid removal
- 2 color separation
- 3 volume reduction by breaking or crushing
- 4 packaging and shipping
- 5 final treatment.

In many recycling programs, consumers sort glass containers according to color and remove labels, metal rings and bottle tops before delivery at waste disposal sites (Germany). In other cases, sorting according to color occurs in the glass recycling industry. Since colored glass wastes cannot be used in some applications (e.g. production of new clear glass), color sorting is important. Until recently, color separation was carried out manually, but nowadays specially designed laser equipment can sort out glass, rapidly and accurately. Color sorting based on transparency, employs light from different kinds of lamps and lasers. In laser applications, partition of light to the sensing device is guided very elegantly by a rotating mirror and optical fiber devices (Figure 15.3). As regards metal detection, theoretically, all non-ferrous and ferrous metals can be detected with a metal detection device and subsequently removed through a reject mechanism. The system sensitivity to non-ferrous metals depends on the conductivity, the shape and the size of individual metal particles. The design and construction of an effective and economically viable metal detector for a glass recycling industry is more difficult than it seems (Dalmijn *et al.*, 1995). However, prior to recycling the colored glass, stones and ceramic particles must be meticulously removed. The detection of ceramic materials in glass cullet usually makes use of the properties of transmission or reflection of light since a laser generated beam of light falls on to a sensing device. For every opaque particle this beam will be broken and a signal will be transmitted to the sensing device. This information will be further processed with an electronic device and one or more blasting valves will be activated to refuse the undesired particle. This type of sorting device is considered to be very rapid and reliable. The final product quality is usually determined by new microwave-based techniques (Dannheim and Hadrich, 1998).

Glass breaking is not desirable if it occurs before color separation. In certain mixed waste stream processing systems, the glass fraction of the waste stream simply becomes part of grit residue, which is either land filled or just becomes a component

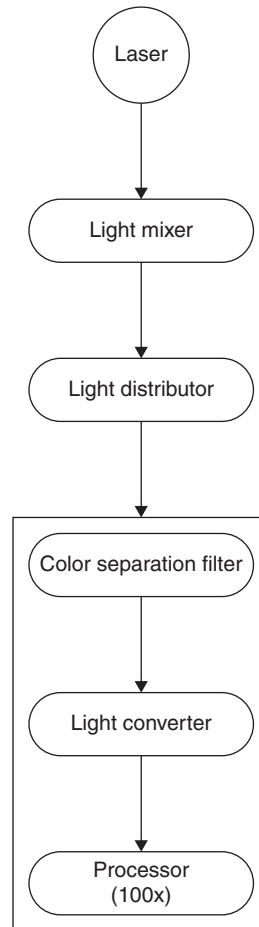

Figure 15.3 Glass laser sorting system (adapted from Arvanitoyannis and Bosnea, 2001)

of a composted waste product. In compost, glass particles usually prove to be beneficial because they have similar properties to sand. Where glass containers are to be recovered for usage in the glass manufacturing industry, color sorting has to occur before breakage, while metal neck rings, paper labels and food residues may be removed after initial breakage. After breakage, glass is packaged, stored or shipped to the market (Choudhary and Huff, 1997). The storage is an essential part of glass recycling, since only collection of a considerable amount of glass will ensure the economic viability of the recycling process and marketing. Broken glass storage should provide the conservation of glass in good condition until packaging occurs. Glass cullet of high quality is usually packaged in paperboard and employed for special applications. Occasionally, broken glass is shipped unpacked in containers (Anon, 1995a). As soon as the glass cullet is delivered to industry, a second sorting takes place, in order to assure the desired quality of the final product. Then glass cullet is mixed with raw materials used in glass production. After mixing, the batch is melted in a furnace

Table 15.7 Energy and emissions from recycled and virgin glass production

Source	Recycled glass (100%)/tonne produced	Virgin glass/tonne produced	Savings/tonne recycled glass produced	Savings/tonne recovered glass used
Energy consumption (GJ)	5.8	9.6	3.8	3.7
Air emissions (g) particles	428	17780	17352	16831
CO	57	105	48	47
NO _x	1586	2270	684	663
N ₂ O	12	106	94	91
SO _x	2652	3927	975	946
HCl	6	75	69	67
HF	2.4	1	-23	-22
Ammonia	2	4	2	1.9
Lead	16	0	-16	-15.5
Water emissions (g)				
BOD	1	1	0	0
COD	2	4	2	1.9
Total organic compounds	20	26	6	5.8
Solid waste (kg)	29.3	4.0	-25.3	-24.5

Adapted from Arvanitoyannis and Bosnea, 2001

at 1425–1535°C, depending on the percentage of cullet contained in the batch. The more cullet used the less heating is required for melting. The melted glass is pumped into a forming (blowing) machine where it assumes its final shape (Stotzel, 1997).

Glass recycling and the environment

The usage of recycled glass has the advantage of reducing furnace temperatures required for raw materials melting. The amount of saved energy can theoretically be calculated with the following formula:

$$\text{Saved energy} = 0.25 \times \% \text{ recycled glass cullet used}$$

Although, data related to glass manufacture from raw material are not available, the consequences and energy consumption can theoretically be calculated, while several models have been suggested for that purpose. The proper energy usage within the industry is one of the major goals of industrial management and government, since it represents 10% of total operating costs. By employing advanced and sophisticated technologies, energy costs can be significantly reduced as shown in Table 15.7. Several organizations and agencies were founded in order to offer advice to recycling implicated members regarding the improvement of the recycling system and recycling rates (Kannah, 1995; Hamann *et al.*, 1995; Krauss *et al.*, 1995; Schaeffer, 1996). A problem that glass manufacturers need to face is the exploitation of the glass industry waste. For several years, filters, pipes and discarded furnaces have caused significant

problems related to the release of hazardous substances. Part of those residues is recycled or undergoes appropriate treatment. Another problem that has to be urgently confronted resides in the lead containing crystal items that can cause health problems to consumers. As a result, international organizations have set limits regarding the use and presence of lead in packaging materials, such as glass, crystal and ceramics (Wachter and Seiler, 1995; Anon, 1995a; Nag and Jarausch, 1995; Gutmann, 1996). The glass recycling process is given in Figure 15.4.

Roundput is one of the most important principles of the development of both natural and industrial ecosystems and is especially important for the analysis of an ecosystem's dynamics and overall functioning, as it is related to an extent to which energy and matter are recycled and used in a cascade-type operation. Two modeling case studies from the UK and Switzerland were studied where increasing recycling rates for plastic and glass would improve the energy budget of the waste management program and, therefore, benefit the corresponding industrial ecosystems. In the first case study, it was shown that the major source of energy savings from glass recycling is through increased use of cullet in glass manufacture (5.4% reduction in total energy consumption with 100% glass recycling when compared to the present-day situation). In terms of energy consumption, recycling is the preferred waste management option, even if a large proportion of the recycled glass is diverted for use as aggregates. Further energy savings could be achieved by the introduction of a city-wide kerbside collection scheme, which would result in an estimated maximum reduction (100% recycling rate) of 7.6% in energy consumption for processing of the Southampton household glass wastes. In the second case study, the situation in which all wastes are burned at an MSWI plant is compared with two scenarios assuming that 8.1% of the plastic is diverted into a cement kiln (mixed plastics; scenario 1) or a mechanical recycling plant (polyethylene, polypropylene, polystyrene; scenario 2). The resulting net primary energy consumption values for both scenario 1 (5.85E8 MJ or 60% relative to the reference scenario) and 2 (7.46E8 MJ or 76.6% relative to the reference scenario) use less primary energy than the reference scenario (9.74E8 MJ). This means that, from the point of view of resource consumption, the diversion of plastics waste away from the MSWI plant has a beneficial effect. Therefore, the increased recycling of glass and plastic would benefit the industrial ecosystems in terms of energy savings. This is similar to the patterns observed in most natural ecosystems and a careful consideration of this similarity within a framework of industrial ecology should help to reduce the conflict between the two systems (Krivtsov *et al.*, 2004).

A fundamental challenge of sustainable development is to deliver massive improvements in resource efficiency if projected economic growth rates are not to cause unacceptable levels of environmental degradation. An important element in the UK government's strategy to deliver on this compensation for growth agenda has been the policy commitments to increase levels of material recycling. Unfortunately, a number of technical, political and attitudinal obstacles stand in the way of achieving the targeted improvements in material recycling. For example, in the case of waste glass (or cullet), the imbalance between the color mix and arising household and commercial glass container waste in the UK and demand from UK glass container manufacturers, presents a significant barrier to closing the loop on this material flow. Efforts to

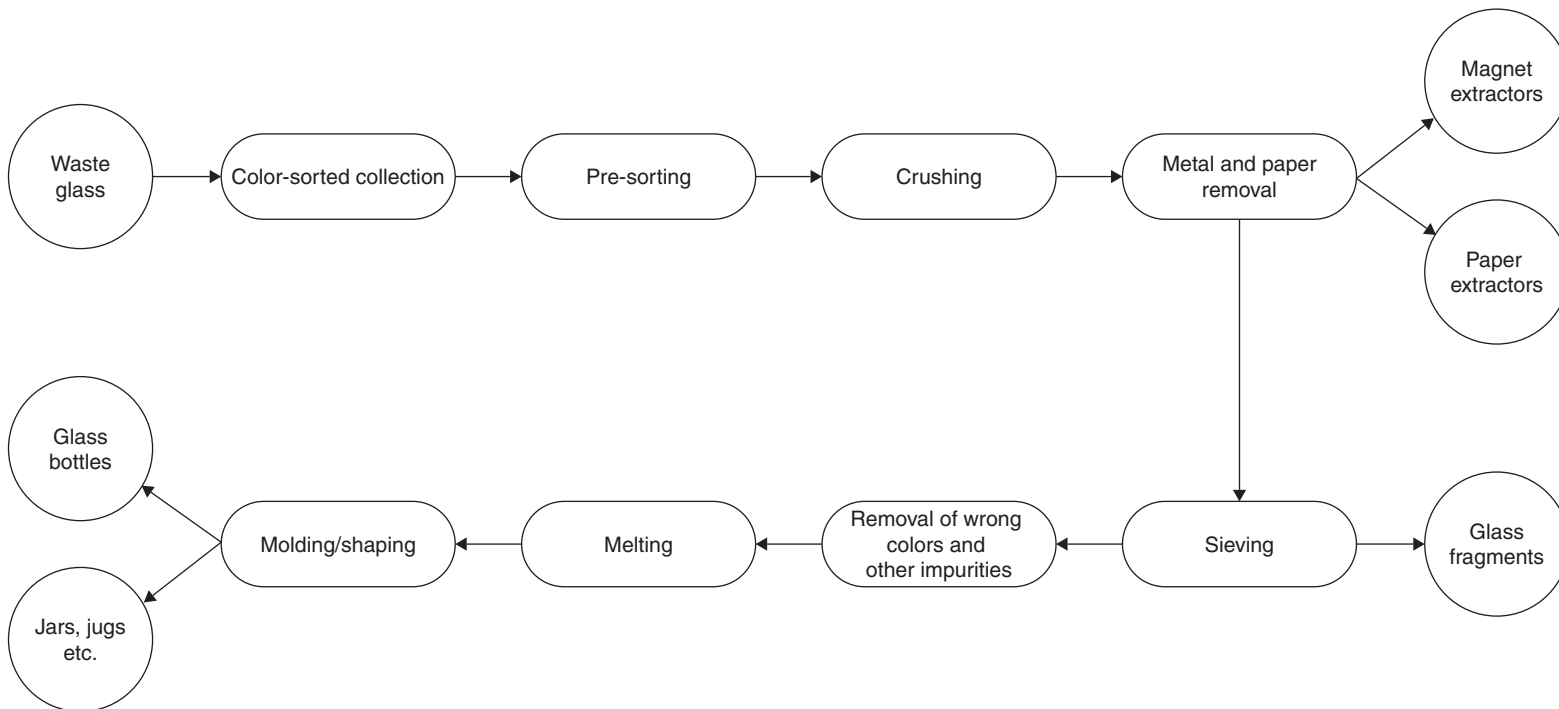

Figure 15.4 Glass recycling process (adapted from Arvanitoyannis and Bosnea, 2001)

resolve this imbalance focused on alternative potential end uses for cullet and the resolution of related technical barriers, particularly in the use of cullet as secondary feedstock for aggregate and cement production. Butler and Hooper (2005) presented an evaluation of the environmental outcomes of various options for the use of cullet with the aim of optimizing the environmental benefits resulting from the recycling activity. Taking energy use as a key environmental indicator, a study carried out for EMERGE Recycling in Manchester has shown that, while there are environmental gains to be made from substituting glass container feedstock for virgin raw material in the production of base aggregates, these gains are significantly less than those accruing from the substitution of cullet for virgin raw materials in the production of glass containers. Consequently, the paper argues that transporting household and commercial arisings of cullet for use in glass container manufacturing in EU countries, where cullet supply and demand does not suffer from the UK imbalance, provides a significantly more beneficial environmental outcome than its use as secondary feedstock for base aggregate and other building materials within the UK.

Limits on current efforts to reduce the environmental impact of packaging are circumscribed by a retail distribution system designed for the efficient management of globalized distribution of continually increasing quantities of consumer goods, in turn dependent on low cost transport and packaging able to protect products from physical deterioration and damage in transit. Thus, an EU Commission Communication on the prevention and recycling of waste, nowhere questions the need for behavioral change incorporating reduced consumption. Instead, it espouses the position that 'strong economic performance must go hand in hand with sustainable use of natural resources and levels of waste' and focuses on measures designed to reduce the impact of waste. It is difficult to reconcile the concept of sustainability, however defined, with this idea of 'sustainable levels of waste' resulting from strong economic growth. The same Communication makes the point that 'as all materials used in an economy sooner or later become waste, major changes in waste generation require changes in production and consumption patterns'. However, no policies for changes in consumption patterns are proposed. To date, all efforts at reducing the impact of packaging waste in the UK have focused on its production, particularly light-weighting. As demonstrated in the case of glass containers, this approach, while making a significant contribution to reducing its environmental impact per unit of production, has not prevented the total quantity of glass container waste continuing to rise. This is symptomatic of current efforts to reduce the environmental impact of consumption, largely based on technical improvements in production and product use efficiencies. At some point, the validity of economic policies based on continually increasing consumption has to be brought into the realm of practical policy making. Without this happening, the ability of the ecosystem to carry the burdens of economic activity will be broken sooner rather than later.

Aluminum

A methodology for planning of integrated recycling concepts taking into account the peculiarities of process engineering in the process industries was suggested by

Schultmann *et al.* (2004). Process models for certain unit operations simulated with a flow-sheet program allow calculation of mass and energy balances considering the technical characteristics and performance of a single process or a combined process chain. Based on principles of thermodynamics, this approach allows an assessment of integrated recycling strategies considering techno-economic as well as ecological criteria. The approach is illustrated with an example from the iron and steel making industry where the injection of plastic waste into a blast furnace is investigated. The iron and steel making industry not only delivers large amounts of products for different sectors (automotive, construction, packaging), but also uses significant quantities of residues from its own processes (by-products like dust and sludges) and from other industrial fields (used products like scrap cars) as input materials. Not only these recycling loops, such as internal re-use of materials or the integration of (external) residues into the production processes, but mainly the characteristics of thermodynamics require non-linear mathematical depiction (Spengler *et al.*, 1998). Application of the hybrid approach to the steel industry showed that the implementation of process-integrated pollution control measures do not necessarily cause a rise in the specific production costs. With suitable technical measures, the iron content of the by-products or residues can be regained in a recycling product like sponge iron and can be recycled within the process chain and reduce the consumption of other iron-bearing input materials. With regard to multinational decision-making, this approach may prove to be a suitable method for defining best available techniques (BAT) as requested in the IPPC-Directive of the European Union, where clusters of technical options for various industrial branches are classified (Rentz *et al.*, 1999, 2001; IPPC, 2000; Schultmann *et al.*, 2004).

In contrast to many other materials, in the recycling of metal there are no quality losses. Compared to primary metal extraction, a 95% savings in energy can be achieved with recycling. The economic value of aluminum has always been the main reason for bringing the material into the loop of metal extraction, processing, use and recovery. Aluminum has been recycled since the days it was first commercially produced and today recycled aluminum accounts for one-third of global aluminum consumption worldwide. In Europe, aluminum enjoys high recycling rates, ranking from 41% in beverage cans to 85% in building and construction and 95% in transportation. With the introduction of the Duales Systems Deutschland in the packaging field, an exhaustive system for acquisition, sorting and re-use of aluminum packaging has been set up. The website of the Duales System Deutschland, however, shows a recycling rate of more than 97% for aluminum packaging in 2002 (Duales System Deutschland, 2004). Cans or tins made of tin plate consist of 99.8% steel with a wafer-thin layer of tin. The recycling of used tin plate cans is possible with easy processes resulting from the unique magnetic properties of steel (Onusseit, 2006). The flow diagram for metal recycling is shown in Figure 15.5.

According to WasteOnline, 3.2 m tonnes of the 26 m tonnes of household waste produced annually come from packaging. Meanwhile, 150 m tonnes of packaging waste come from industry and commerce each year. In the UK, 11% of household wastes is plastic, 40% of which comes from the 15 m plastic bottles used every day. Only less than 3% of these plastic bottles are recycled. Less than 1% of the billion plastic bags used annually are recycled and the majority are used only once (<http://www.thesite.org.uk>). In 2002, steel packaging recycling in the EU 15 reached an average rate of 60%. In

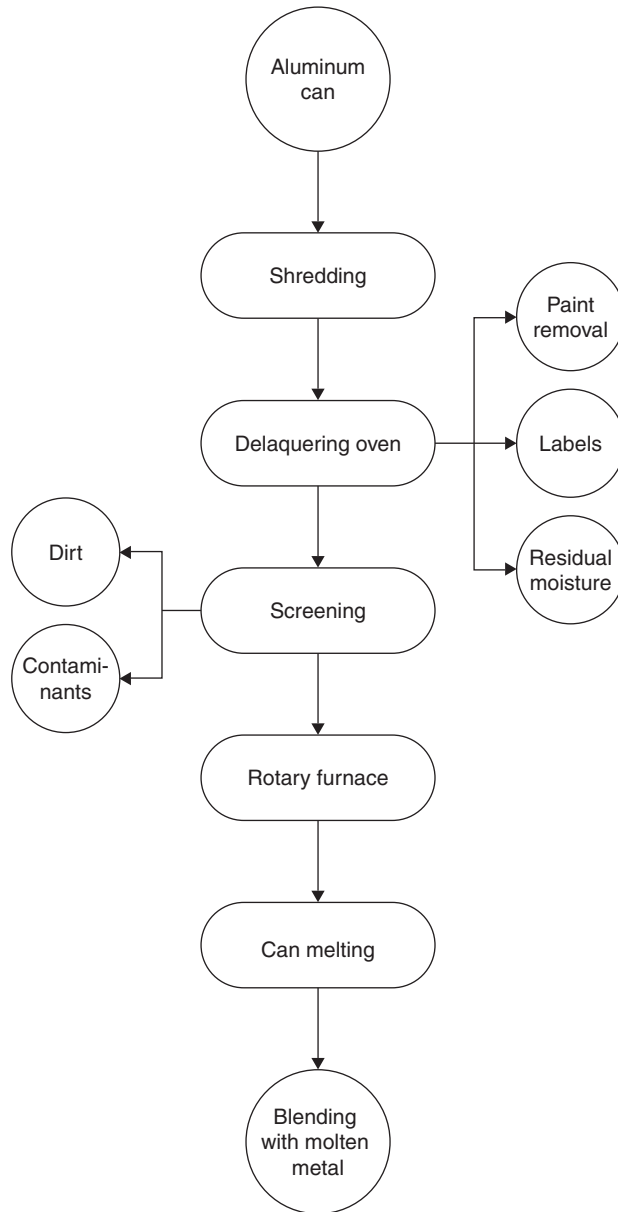

Figure 15.5 Flow diagram for metal recycling (adapted from Onusseit, 2006)

accordance with the 1994 EU Packaging Directive, new EU Member States are actively promoting the collection and recycling of used steel packaging. In terms of meeting the legal requirements, steel contributes significantly to reaching the EU recycling target for metal packaging (steel and aluminum), which the Packaging Directive has set at 50% by the year 2008. In 2002, steel packaging was the most recycled packaging material in Europe, followed by glass at 57%. Across the western half of the continent, recycled quantities have tripled within the space of a decade. A recent study conducted by

Landell Mills for APEAL in Poland, Hungary, the Czech Republic and Slovakia shows that, in 2001, the consumption in food cans reached 1.8 billion units and is projected to grow at the rate of 3.5% per annum. Steel represents 60% of all food packaging in Central Europe (<http://www.packwire.com/news/printNewsBis.asp?id=51810>).

Aluminum in packaging preserves food quality and avoids waste and its low weight reduces fuel consumption and emissions during transportation and means it is suitable for packaging applications where weight is important. Around the world, most high voltage overhead transmission and distribution lines over long distances are made of aluminum. Aluminum is used extensively for the protection, storage and preparation of food and beverages. Aluminum can be rolled into ultra-thin foils which are light, strong and have unique barrier and insulation qualities to preserve food, cosmetics and pharmaceutical products and protect from ultraviolet light, odors and bacteria. Aluminum packages are secure, tamper-proof, hygienic, easy to open and recyclable. Aluminum withstands both heat and cold. It is easy to sterilize for food and medical applications. It is an excellent barrier against liquids, vapors and light. It transmits conducted heat and reflects radiant heat. That is why you can oven-bake a potato in foil or insulate your home with it. Less than an ounce of aluminum sprayed on a polymer forms a thin insulating sheet that can keep a newborn baby warm or save the life of someone on an exposed mountain top (<http://www.world-aluminium.org/applications/index.html>). Aluminum conducts heat extremely well, making it very energy efficient for preparing and serving both hot and cold food. It is non-toxic and imparts no taste or odor. Aluminum beverage cans and food cans have a protective polymer coating applied on the inside to prolong storage life (<http://www.world-aluminium.org/applications/packaging/index.html>). The Swedes have an impressive over 80% aluminum can recycling rate, which makes efforts in the USA look comparatively weak, at a rate of under 50% that has been backsliding from a high of almost 60% in 1992 (Figure 15.6).

Formability is an important consideration in selecting a suitable uni-alloy for the aluminum beverage can: this includes the quality of the material recycled from used cans. The alloy 5017, in chemical composition ranking between the currently used can-stock alloys, is a promising option. The formability data obtained are quite

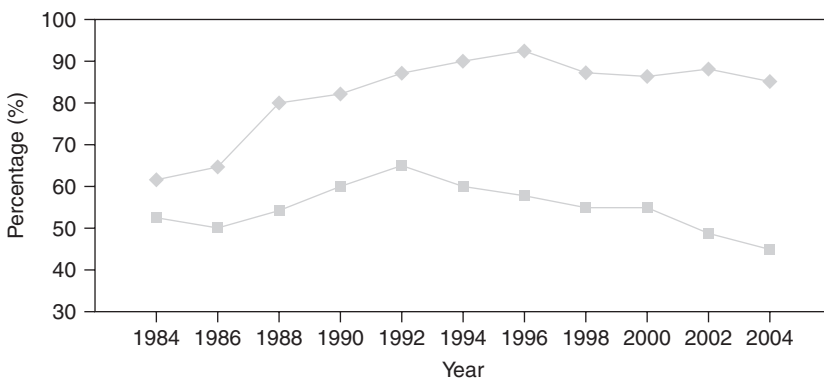

Figure 15.6 Recycling rate for aluminum cans in Sweden and the USA (1984–2004) (◆ Sweden and ■ the USA) (adapted from <http://container-recycling.org/alumrate/gaphs.htm>)

comparable to those for 3004-O (Sillekens *et al.*, 1997). The experiments reveal that the formability data for the 5017-based model alloys change with an increase in Fe content, the extent to which this affects the actual behavior depending on the forming process employed. The overall performance, however, does not decline significantly for the range investigated, which includes an increase in Fe content of up to twice the standard amount.

The new direct conversion technique introduced by Samuel (2003) is characterized by low energy consumption, large metal savings and very low air pollution emission as compared with conventional methods. Figure 15.7 shows a flow chart for the conventional and the new techniques for direct scrap conversion into extruded products. It can be seen that the new technique is characterized by fewer steps, a higher efficiency of recovery and low generation of new scrap. Moreover, the new technique provides the following advantages over the conventional methods:

- 1 powder suitable for the production of green compacts can be processed from aluminum scrap
- 2 the chemical cleaning operation introduced in this technique removes the oxide film from the aluminum surface, which results in high green density (about 80% before sintering)
- 3 the cost of the product is about 59% of the conventional aluminum powder cost.

Usually the energy consumed for the conventional recycling of aluminum is 16–19 GJ/t, whereas in the direct conversion of aluminum chips into compact material only 5–6 GJ of energy per ton is needed. By reducing the number of operations, the direct conversion method allows labor to be reduced to 2.5–6.5 man-hours per ton of the product, while for conventional recycling, this figure is much higher, ranging from 11 to 15 man-hours per ton, including 3 man-hours per ton for the production of ingots, 5 man-hours per ton needed to produce billets and 3–5 man-hours per ton for the production of sections. The benefits of the direct conversion of aluminum and aluminum-alloy chips into compact metal include also a possible reduction in the funds spent on environmental protection as a result of the reduced consumption of ores and energy carriers and less degradation of the natural environment because of reduced air-pollution emission. To sum up, it should be emphasized that the environmentally clean direct conversion of aluminum scrap into compact metal results in savings of 40% in material, 26–31% in energy and 16–60% in labor (Gonostajski *et al.*, 2000).

The most usual process to recycle aluminum employs a rotary furnace which is heated by the burning of fossil fuel. In order to enhance the aluminum yield, a low melting point mixture of salts is charged before the aluminum scrap or the aluminum dross. The salt fluxes universally used are based on equimolar mixtures of sodium and potassium chlorides; this composition corresponds to the minimum temperature of the isomorphous binary system. Fluorides are also frequently added to the chloride mixture; the most common fluorides added are CaF_2 and Na_3AlF_6 . The use of salts generates a by-product known as 'salt cake' that is considered a hazardous waste. Microstructure analysis was the main tool to analyze the morphologies of aluminum

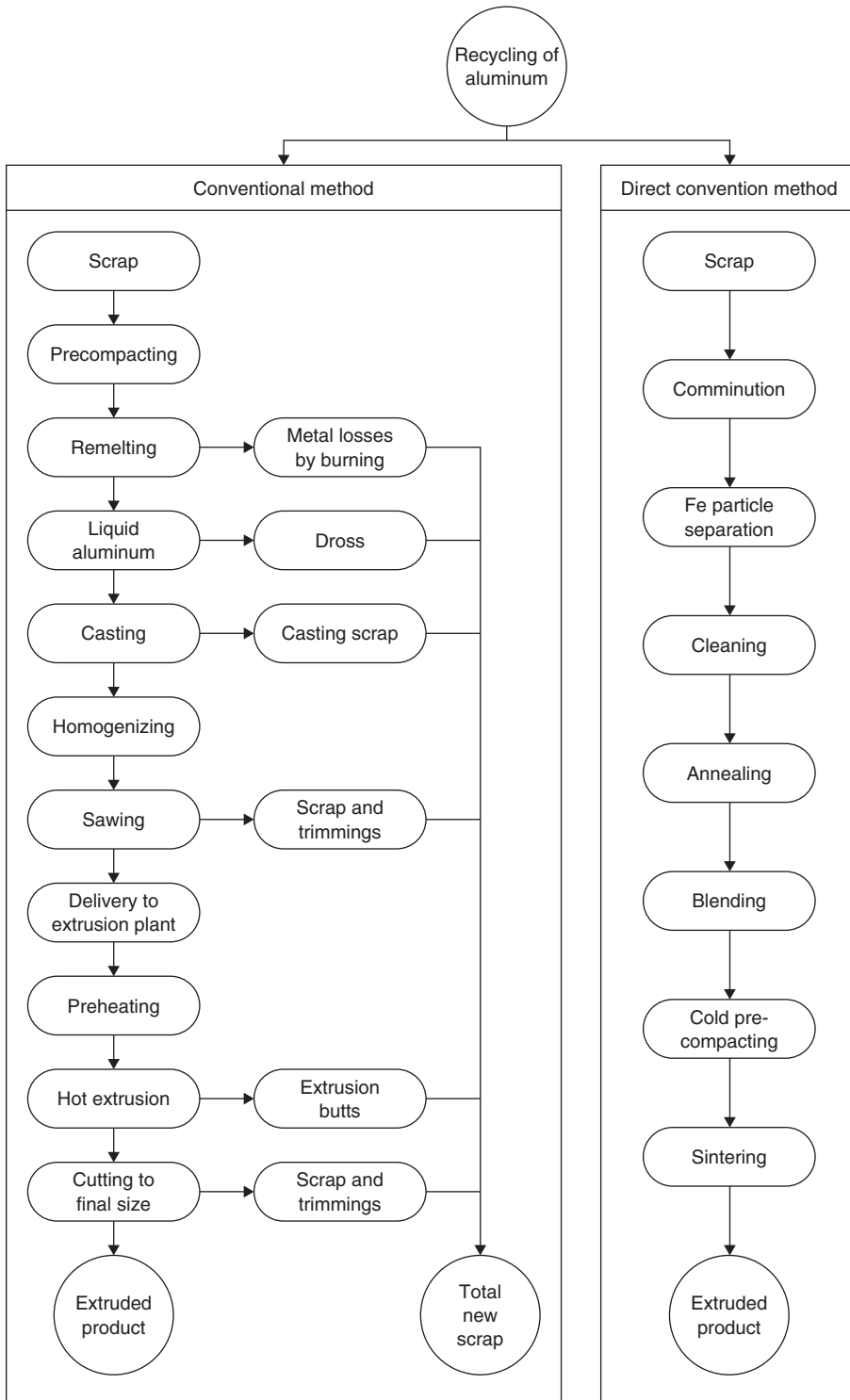

Figure 15.7 Flow charts of recycling aluminum scrap by conventional and direct convention method (adapted from Lazzaro and Atzori, 1992; Gonostajski *et al.*, 2000; Samuel, 2003)

dross and its interactions with liquid salt flux; consequently the study was carried out through the scanning electron microscope coupled with an energy dispersive X-ray spectrometry detector. Drosses collected from aluminum can recycling industries were used. Tests were carried out using equimolar mixtures of sodium and potassium chlorides. The results revealed that drosses are heterogeneous systems composed essentially of oxides and aluminum. The aluminum oxides develop a chain microstructure, with a high specific surface area, that traps aluminum. The molten salt corrodes this structure and breaks the oxide links, consequently liberating the retained aluminum (Tenorio and Espinosa, 2002).

The RECAL Program was implemented in Poland in the form of a marketing campaign for the collection of aluminum cans and in conjunction with an educational program (training sessions, courses and seminars in the field of recycling methods) offered to a large sector of society (school children, their teachers and parents). The success of RECAL has resulted in raising public awareness and increasing aluminum tonnage for recycling purposes. Teachers involved in RECAL activities underlined the educational role of the program, both in the aspect of ecological awareness of the students as well as organizational abilities, group work and creativity. RECAL assistance in the action was highly regarded by all groups of program participants. In their opinion, the RECAL staff was professionally trained and lectures, seminars and materials were well prepared. Teachers and students underlined that a future RECAL activity should be expanded to a greater number of respondents mainly in kindergarten children, students of higher grades (high schools, gymnasium) and adults. In accordance with the constant rise of beverages packaged in aluminum cans in Poland (expected 1 400 000 000 in the year 2000), an increase in environmental public awareness is required. RECAL activity should be viewed as a case study of the best practice for other educational programs that face similar difficulties in raising awareness (Godzinska-Jurczak and Bartosiewicz, 2001a).

Aluminum and aluminum-alloy chips can be recycled by the direct conversion method, which is characterized by low-energy consumption and large material savings. The most suitable way of recycling the chips is by processing through hot extrusion. This method is relatively simple and it limits itself to cold press molding and hot extrusion. The main conclusions are summarized as follows:

- 1 bearing composites from aluminum and aluminum bronze chips can be manufactured without metallurgical process
- 2 the method involves granulation and cleaning of chips, cold compaction, hot extrusion and heat treatment during which the reciprocal diffusion of copper and aluminum takes place and leads to good tribological properties of composites
- 3 composites with a 15–22% reinforcing phase content and with larger size particles (2–4 mm) have the best tribological properties
- 4 to obtain the good diffusion bonding of particles separated by a layer of oxide, three conditions must be fulfilled: high temperature, large shear plastic deformation and thin aluminum oxide layer
- 5 there is no significant difference of the effect of various reinforcing phases on the frictional properties of composites (Gonostajski *et al.*, 2002).

The potential of nitriding combustion was investigated in terms of an energy-saving and environment-friendly process to produce high performance nitride ceramics or recycle wastes to usable ceramics. It is possible to convert the reclaimed silicon produced in zinc smelting to Si_3N_4 ceramics, both the silicon sludge discharged in silicon wafers production and the aluminum dross discharged in aluminum foundry to sialon based ceramics. The monolithic $\text{Si}_2\text{N}_2\text{O}$ ceramics can be synthesized from the mixture of desert sand and reclaimed silicon as well. It would be useful to find applications for these recycled products in powder, porous and dense forms (Miyamoto, 2003).

In order to maximize the efficiency of ever increasing aluminum recycling, different mutually related aspects need to be optimized. Economic efficiency of aluminum recycling is greatly dependent on the costs arising at different stages of the recycling process. Among these, transportation costs represent a very important part of overall cost balance. A general model, based on the principles of reverse logistics, was developed and applied with the aim of reducing the extent of internal aluminum scrap transportation required between certain production units of an aluminum manufacturing plant. A linear optimization model was applied for calculating minimum annual transport costs and the optimal way of in-plant transport for two transport models in order to determine the most efficient option. In case of in-plant aluminum recycling only collected aluminum materials were transported which means that the most important factors in this case were fixed transport costs and variable transport costs, the latter depending on distance, transported quantity, energy used for transport and other operating costs. In the first transport model, the direct transport of collected aluminum scrap from each individual source to in-plant processing units was assumed. In the second transport model, one collection site was assumed where scrap is collected and then transported to in-plant processing units. The optimization model was also applied for determining a dependence of optimal transport model on annual quantities transported internally and on the distances between sources and processing units. It was found out that the annual transported quantities and distances between sources and in-plant processing units have a significant impact on the optimal transport model. The developed optimization model showed that environmental and economic objectives were not always in conflict. The aspects affecting the reverse logistics model for in-plant recycling were made clear and discussed (Logozar *et al.*, 2006). This model implies that each of five sources, which are located adjacent to each unit operation of foil production (Figure 15.8), represents its own collection site.

The ever increasing amount of electronic scrap and the steadily decreasing contents of the precious metals used in electronics, as well as the ever-growing environmental awareness, challenge such conventional precious-metal-oriented recycling techniques as pyrometallurgy. Separation and beneficiation of various materials encountered in electronic scrap might provide a correct solution ahead. In this context, a mechanical separation-oriented characterization of electronic scrap was conducted in an attempt to evaluate the amenability of mechanical separation processes. Liberation degrees of various metals from the non-metals, which are critical for mechanical separation, were analyzed by means of a gain counting approach. It was found that metallic particles below 2 mm achieve almost complete liberation. Particle shapes were also

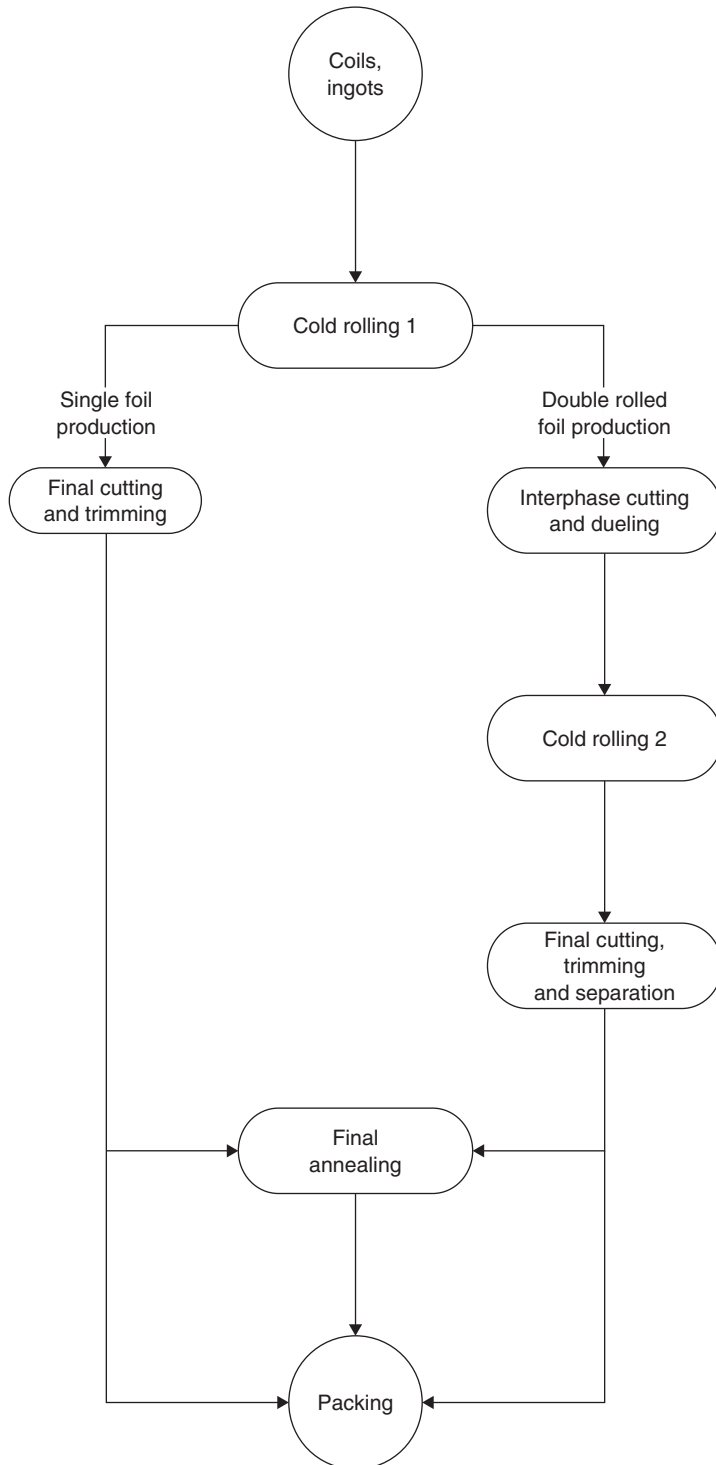

Figure 15.8 Scheme of aluminum foil production unit (adapted from Logozar *et al.*, 2006)

quantified through an image processing system. The results obtained revealed that the shapes of the particles, as a result of shredding, were heterogeneous, thereby complicating mechanical separation processes. In addition, separability of various materials was ascertained with a sink–float analysis. It was shown that density-based separation techniques will be viable in separating metals from plastics, light plastics (ABS, PS and PVC, etc.) from glass fiber reinforced resins and aluminum from heavy metals. Specifically, a high quality copper concentrate can be expected with density-based separation techniques. Moreover, FT-IR spectra of plastics pieces from the light fractions after the sink–float testing showed that PC scrap primarily contained ABS, PS and PVC plastics with the density range of $+1.0\text{--}1.5\text{ g/cm}^3$, whereas PCB scrap mainly contained glass fiber reinforced epoxy resins plastics with the density range of $+1.5\text{--}2.0\text{ g/cm}^3$ (Zhang and Forsberg, 1997). The metal assay approach for float and sink products is given in Figure 15.9.

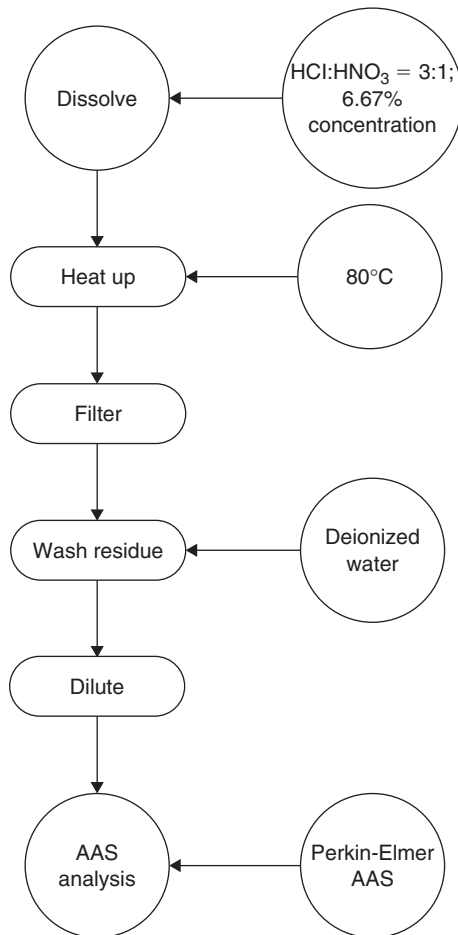

Figure 15.9 Metal assay approach for float and sink products (adapted from Zhang and Forsberg, 1997)

Disposal of highly saline industrial by-products in landfills is not permitted in member states of the European Union, such as Germany. Large amounts of such by-products thus have to be disposed of in alternative ways. In many countries, bare potash mining residue mounds, consisting almost entirely of rock salt (NaCl), pose environmental problems. Covering such mounds with soil or soil-like material could help to reduce the yearly amount of briny runoff. A fine-granular saline aluminum recycling by-product (ALRP) has been proposed as a soil substitute to cover rock salt residue mounds. Use of this by-product as a combined soil substitute and surface barrier is not considered to be a landfill disposal, but as a beneficial by-product re-use. To judge the feasibility of ALRP for this purpose, its properties must be known. A study was initiated to determine the physical characteristics of an industrially produced ALRP mixed with the flue gas desulfurization by-product (FGDP) of a coal combustion power plant. It was found that the texture of both ALRP and ALRP-FGDP mix was silt loam. Bulk densities of ALRP and ALRP-FGDP were 0.93 and 0.88 Mg/m³ and the corresponding salt contents were 50.0 and 35.5%, respectively. The erodibility factor, K, of pure ALRP was estimated as 0.65 Mgh/ha/N. Because of the stabilizing effect of FGDP, this factor was reduced considerably in ALRP-FGDP. The water-holding capacity of unwashed ALRP was 44.5% and of washed ALRP-FGDP 61.8%. In view of its physical properties, ALRP-FGDP seems to be suitable as an evaporation enhancing, runoff reducing cover material for potash mine residue mounds, even on steep slopes. Use of ALRP, mixed with FGDP, as a soil substitute in a surface barrier, thus seems to be environmentally meaningful. However, the high salt content initially prevents plant growth. With time, after the salt has been leached, the material seems able to support plant growth, which would further reduce runoff. The physical and hydraulic parameters determined in this study may serve future users of similar by-products (Hermsmeyer *et al.*, 2002).

A more general model of the 'recycling problem' was used to re-examine the *Alcoa* antitrust case of 1945. There are three primary empirical results:

- 1 in the *Alcoa* scenario, the recycling problem had been in a steady state since the early 1920s
- 2 the primary source of Alcoa's market power, in contrast to previous work, was that most of the aluminum sold by Alcoa was used in goods that were not economical to recycle
- 3 the existing, competitive secondary market was welfare-reducing, relative to a monopoly in all aluminum production (Gant, 1999).

According to Yerushalmi (1992), to prevent the undesirable reactions due to aluminum dross recovery, the pH in the digester must be maintained below 8 and preferably above 5 through magnesium chloride addition. This salt suppresses the reactions that increase the leaching liquid pH since it reacts with the hydroxyl ions in alkali solutions to form non-dissociated Mg(OH)₂ and HCl. In addition to the recovery of metallic aluminum, salt flux and magnesium chloride, the process generates a waste, known as non-metallic (NMP), which is usually disposed of in landfills. Many secondary recycling industries in Brazil recover metallic aluminum using a simple

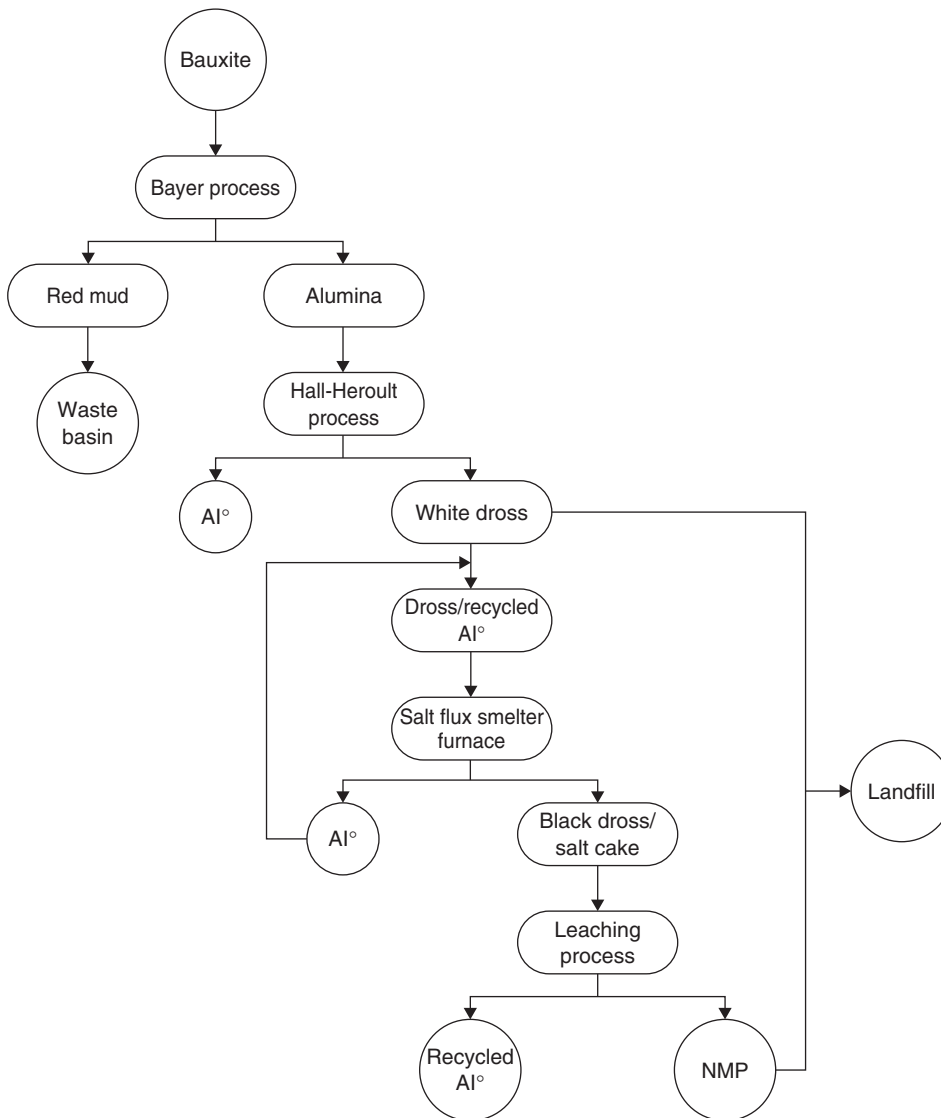

Figure 15.10 Aluminum schematic recycling process in Brazil (adapted from Shinzato and Hypolito, 2005)

process of crushing and melting of white dross in the presence of a salt flux (NaCl/KCl). Therefore, new dross is generated (black dross and salt cake), which are reused as raw material by tertiary aluminum industries (Figure 15.10). Many tertiary aluminum-recycling companies in the Sao Paulo metropolitan area operate using a simple method for treating black dross. In this process, the dross is crushed using a vertical hammer mill to release the metallic portion. The remaining material is water leached in a rotary drum. The recovered material is sorted by size using a 20-mesh sieve. Particles larger than 20 meshes (containing about 60% (wt) to 80% (wt) of Al) are sent to secondary industries for remelting. Particles smaller than 20 mesh, which represent 25% (wt) of Al can be sold to steel manufacturers as an exothermic product.

During the dross leaching process a semi-liquid waste, rich in soluble salts, is produced, which is disposed of in tanks for decanting the solid fraction. The measured pH of the leaching solution in those tanks is about 9 (Shinzato and Hypolito, 2005). However, a positive consideration based on this study refers to the other tests (dimensional, humidity and adsorption) and the acceleration of working time. This decrease in the working time will certainly result in an increase in the production of the concrete blocks, since they will be available for sale faster than the ones currently produced. Another important use of NMP would be as a synthetic aluminous aggregate for refractory concrete, as well as cements of high alumina content specifically designed for high-temperature applications. The commercial use of NMP can significantly reduce the quantity of waste disposed of and also contribute to preservation of the environment. Moreover, using aluminum waste in preparing aluminum products, such as aluminum hydroxide, will certainly be more economically feasible than the use of bauxite.

Gonostajski and coworkers (2001b) suggested a new method of recycling aluminum-alloy chips. This method consists of composites of the conversion of the chips directly into a finished product. The method was applied to the production of composites characterized by good strength properties at elevated temperatures. As a reinforcing phase the FeCr powder with particle size below 75 μm was used, the amount of that phase was changed from 6 to 14 wt%. The process was performed in the following steps: granulation of chips, mixture of granulated chips with FeCr powder and zinc stearate as lubricant, cold compaction of the mixture into the billets, presintering and hot extrusion. The main conclusions of this method can be summarized as follows:

- 1 the effect of ferro-chromium content on the flow stress is dependent on the applied temperature and at higher temperatures the best results were obtained for 6% of reinforcing phase
- 2 the better mechanical properties were obtained for composites made from smaller fraction of granulated chips (below 0.5 mm) than bigger (0.5–1.0 m)
- 3 the process was performed in the following steps: granulation of chips, mixing of granulated chips with FeCr powder and zinc stearate as lubricant agent, cold compaction of the mixture into the billets, presintering and hot extrusion
- 4 the method can be used to manufacture the products in the form of bars, sections and pipes, which can be formed in further operations
- 5 good bonding of particles separated by a layer of oxide needs large plastic deformation.

The waste composition analysis results of Cathay Pacific flights indicate that there are many items in the current in-flight services waste streams that can be minimized and recycled (Li *et al.*, 2003). In the waste composition analysis, clean paper (mainly newspapers) was the largest component, ranging from 32 to 71% of the total weight of the in-flight waste. The next major component was plastic material, particularly transparent PS items (drinking cups and food covers), which accounted for up to 13% of the total weight of the in-flight waste streams. Aluminum cans accounted for up to 4% of the total waste on some flights. Food waste in the food carts was another important waste component resulting from the in-flight services. Based on the composition analysis and current recycling opportunities, clean paper items, transparent PS items

and aluminum cans were identified as the most promising recyclable materials. These materials can be separately collected on board for the recycling program. The recyclable items can account for up to 45–58% of the total galley and cabin waste from in-flight services. The waste reduction and recycling program has the potential to contribute greatly to local and global environmental protection and to save substantial operation costs for the airline industry.

A new method for recycling aluminum alloy chips by cold and hot pressing followed by hot extrusion was studied as well as the possibility of using this method to recycle aluminum matrix composite chips. It was found that hot extrusion of cold or hot pressed samples could satisfactorily promote the consolidation of the chips. Hot extrusion of hot pressed samples proved to be the best route from the point of view of mechanical properties but, on the other hand, hot extrusion of cold pressed samples route has higher cost profit. Aluminium AA6061 matrix composite reinforced with Al_2O_3 recycled by cold pressing and hot extrusion was compared with the primary material produced by conventional casting process from which the chips were obtained. Due to the refinement of the microstructure and the dispersion of the aluminum oxide caused by the extrusion process, the ultimate tensile strength (UTS) and the hardness were higher for the recycled material than for the former composite (Fagagnolo *et al.*, 2003).

The feasibility of recycling red mud and fly ash in the aluminum industries by producing glasses and glass-ceramics techniques was highlighted by Yang *et al.* (2006). The red mud is a CaO-rich slag from the sintering process of Al_2O_3 production. The fly ash, a convenient SiO_2 -rich and Al_2O_3 -rich solid waste directly collected from electrostatic precipitator in the coal-combustion power plant, is another main raw material. The glass-ceramic of CaO- SiO_2 - Al_2O_3 system mostly made from the red mud and fly ash was developed successfully. The results show that the total amount of both the industrial solid wastes of the red mud and fly ash is up to 85 wt%, which promises less raw materials cost, prominent economic benefits and environmental benefits.

In a typical secondary aluminum process, the scrap feed is charged into a rotary furnace, melting and mixing under a salt layer in the furnace. The complexity in such a pyrometallurgical process is due not only to the high temperature effect and the complex chemical reactions, but also to the highly complex scrap feed with a distributed nature of aluminum types, compositions, sizes, shapes, paintings and other contaminations. In a study, user sub-models, which represent the distributed nature of the scrap feed, were developed and integrated into a computational fluid dynamics (CFD) based process model of a rotary furnace (Zhou *et al.*, 2006). Aluminum scrap was classified into several groups depending on their properties, e.g. size, establishing a discretized population balance model (PBM). The melting behavior of aluminum scrap was simulated with the exchange of information between the melting sub-model and the CFD calculations. In addition, the sub-model for scrap burn-off was also developed and integrated in the CFD framework providing distributed burn-off rates. Simulations of the melting process were made to model the flow and thermal phenomena in such a furnace and the influence of the scrap size, shape and quality, as well as burn-off rate were studied.

Several models for estimating the potential arising from metal scrap were developed by Melo (1999). The modeling approach consisted of first aggregating metal-containing

products into end use categories and then employing statistical distributions to describe the service life of products in each category. This statistical approach was applied to the German aluminum market. Due to the absence of historical data regarding the age of products upon disposal, it is very difficult to single out a model as being particularly appropriate for representing lifetime. The choice is made on the basis of considerations, such as the degree of complication of the calculations involved using the model and qualitative information gathered from experts. Naturally, modeling uncertainty on the basis of subjective judgments by experts is not exempt from criticism. We considered the normal, Weibull and beta distributions as life models. In contrast to the normal, the other two models have the advantage of assuming a wide variety of shapes that are likely to arise in practice. In terms of analytical tractability, the Weibull distribution is easier to manipulate. The results obtained disclosed that the proposed models yield better estimates of old scrap than commonly used approaches that assume a fixed service life for products. The fixed lifetime procedures are highly influenced by fluctuations in the consumption of metal and can significantly underestimate or overestimate the scrap potential. Hence, the information provided by such approaches may naturally have a negative impact on the planning of future activities in the secondary and primary industries. Although those models were applied to the German aluminum market, they can easily be extended to other countries and metals as well. A concluding remark is that more attention should be focused on the development of reliable techniques to estimate metal scrap generation, since they provide valuable assistance in decision-making both in secondary and primary industries.

A robust design method for reducing cost and improving quality in aluminum recycling was developed by Khoei *et al.* (2002). An experimental investigation into the process parameter effects was presented to determine the optimum configuration of design parameters for performance, quality and cost. The Taguchi method is applied initially to plan a minimum number of experiments. Orthogonal array techniques are used to investigate the simultaneous variation of several parameters and the investigation of interactions between parameters. Matrix experiments using standard L4 and L9 orthogonal arrays were employed to evaluate the effects of parameters in recycling of aluminum dross and scrap materials. A statistical analysis of signal-to-noise ratio was followed by performing an analysis of variance (ANOVA), in order to estimate the optimum levels and determine the relative magnitude of the effect of various factors. Finally, a historical data analysis based on the response surface methodology was carried out using a Taguchi orthogonal analysis. Experimental results were shown for an L18 orthogonal array illustrating a good agreement between the optimum factor levels suggested by the signal-to-noise ratios and those obtained from the response surfaces.

The recycling of the aluminum content of LPM in Germany is actually done at a resource orientated recycling quota of 59%. The presented calculations show that by increasing the recycling quota to the optimal one concerning energy demand, 27.6% of the energy, which is required now, could be saved. A further increase in the resource orientated recycling quota over 79% would not be reasonable concerning the overall energy demand including primary energy as well as the heat content of burnt materials. Although remelting of aluminum requires less energy than primary production, at high recycling quotas the results identify a turning point. Above that point,

methodological and social aspects (like consumer behavior) influence the recycling practice and therefore the calculated results. The development of the scenario concentrates on increasing the recycling quota. Here the new technology of fully automated sorting is a big step towards highly efficient metal recovery and reduced energy requirement. At the same time, further fractions of usable materials are won. Reaching higher sorting selectivity of one of these materials might result in quality losses of the other ones. Also pyrolysis can be identified as an important part of a material efficient process chain. Besides the technical improvement, new strategies to increase the overall recovery rate of secondary raw materials have to be considered. Here the collection quota appears to be of great potential towards increasing the recycling efficiency. In this evaluation, all packaging material which is not utilized by the DSD is assumed to be collected via municipal waste collection. Besides disposal in landfill sites, one-third of the municipal waste is incinerated. Two-thirds of the incineration slag are processed for further utilization, e.g. for road construction. Therefore, the metallic content must be extracted. This is done in a slag treatment plant which mainly consists of a shredder, sieves, a magnetic separator for ferrous metals and an eddy current separator to recover the non-ferrous metals (Figure 15.11). Since most of the metal in the slag is ferrous, the plant is optimized for the extraction of ferrous metal and the non-ferrous metal fraction is a by-product. The non-ferrous fraction consists of aluminum, copper and zinc, which are separated in a sink–float process. The aluminum fraction is molten in a rotary drum furnace (Quinkertz *et al.*, 2001).

Xiao and Reuter (2002) investigated the melting behavior of four different turning scraps. The melting experiments were carried out at 800°C under a nitrogen atmosphere. The basic salt flux used in the experiments contained 70 wt% NaCl, 30 wt% KCl with additional and varying amount of Na_3AlF_6 . In general, it has proved that scrap distribution, contaminant, type and size of the scrap have a significant effect on the melting behavior. The metal recovered from the turning scrap ranges from 84 to 95 wt%, representing the metal content of the scrap if potential reactions of the salt flux with metal were disregarded. The recyclability of the turning scrap B (95.3 wt% recovered metal) and C (94.5 wt% recovered metal) is better than scrap A (84.3 wt% recovered metal) and D (91.8 wt% recovered metal). By increasing the amount of cryolite in the salt flux, the percentage of metal recovered was increased but not substantially. The accumulation of the metal droplets was improved with increasing cryolite from 5 to 15 wt%. The accuracy of the classification for the turning scrap is limited due to the characteristics of the scrap shape. For scrap B, the percentage of metal recovered and the accumulation degree of the metal droplets is increased with turning size. The distributed metal yield as a function of scrap type and size is the basis for establishing a future statistical model to ensure better product quality in the recycling industry.

A complete mathematical model for the pyrolysis of coated waste of aluminum was developed by Marias *et al.* (2005). It is based on a coupling between two sub-models representing:

- 1 the bed of solids to be reprocessed and the kiln itself
- 2 the gaseous phase where the volatiles are released (as a result of pyrolysis) and where their oxidation takes place.

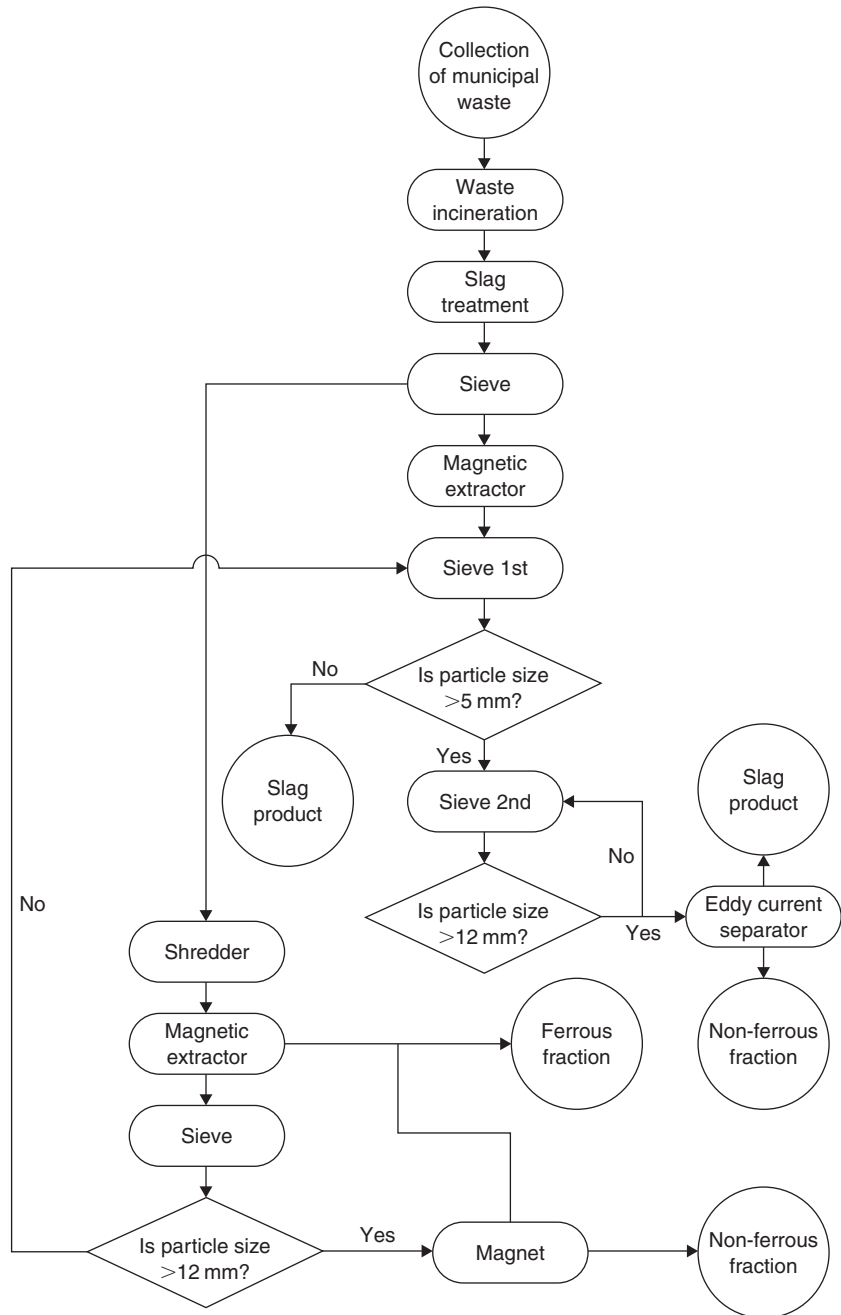

Figure 15.11 Process chain of slag processing with additional steps of metal recovery (adapted from Quinkertz *et al.*, 2001)

The first of these sub-models considers the bed of solids as a plug flow reactor where pyrolysis occurs. It takes into account heat transfer by conduction in the kiln as well as heat transfer with the surroundings (both ambient air and electrical heaters) and with the kiln. The second of these sub-models deals with processes occurring within

a gaseous medium where turbulent combustion occurs. Turbulence chemistry was taken into account. Comparisons with experimental investigation were performed in the case of particles of covers of cans. They are congruous, at least qualitatively. Indeed, the value of 450°C seems to be the ignition value for which pyrolysis begins to occur (for the particular coating in question). Moreover, because of the oxidation of the volatiles and because of the mode of operation of the furnace (counter-current), a high amount of the heat released by combustion is received by the bed in the vicinity of the first heater. This would indicate that perhaps there is no need to preheat the aluminum to be reprocessed (if the heating rate of a particle is the same). Moreover, because of the value of the ignition temperature, there is probably no need to set the temperature inside the second heater to 570°C. These kinds of conclusions could diminish the cost (from an energy-saving point of view) of the operation of reprocessing. Moreover, they could help diminish the level of temperature reached inside the furnace and then diminish the risk of the oxidation of aluminum.

Rabah (2003) made an attempt to recover standard aluminum–magnesium alloy(s) and some valuable salts from used beverage cans (UBCs). The suggested method updated the current recycling technology by augmenting removal of the coating paint, decreasing magnesium loss during the melting process and improving hydrochloric acid leaching of the formed slag. Iron impurity present in the leaching solution was removed by oxidation using oxygen gas or hydrogen peroxide and filtered as goethite. The obtained results revealed that a mixture of methyl ethyl ketone/dimethyl formamide entirely removes the paint coating at room temperature. The process compared favorably to the current methods involving firing or swell peeling. The coating decomposed to titanium dioxide by heating at 750°C for 30 min. Standard compositions of Al–Mg alloys are formulated using secondary magnesium. The extent of recovery (R) of these alloy(s) is a function of the melting time and temperature and type of the flux. The maximum (R) value amounts to 94.4%. Sodium borate/chloride mix decreases magnesium loss to a minimum. The extent of leaching valuable salts from the slag increases with increasing the molarity, stoichiometric ratio and leaching temperature of the acid used. Removal of iron is a function of the potential of the oxidation process. Stannous chloride has been recovered from the recovered and dried salts by distillation at 700–750°C.

Paper/carton

In spite of synthetic packaging materials and electronic media, internationally paper and board consumption is increasing steadily. While in 1950, about 50 million tonnes of paper were produced worldwide, in 1998, approximately 300 million tonnes were produced. In the year 2010, 400 million tonnes are projected. In Europe, Japan and the USA, where one-fifth of the world population lives, more than two-thirds of the paper is consumed. To make this increase in paper production possible and for saving resources at the same time, paper recycling has been intensified steadily in the last decades and has now reached a high technical level. Most of the products made of paper only have a life span of a few days (e.g. newspapers) or a few weeks (e.g. packaging). The increase of recovered paper use in industrialized countries is determined by problems of disposal.

Paper recycling in Europe increased markedly throughout the 1990s. The amount of paper collected and recycled at the end of the decade was roughly two-thirds more than at the beginning. This means that the recycling rate (percentage of recovered paper use compared to total paper consumption) was 53.2% in 2003, compared to about 40% in 1990. Thus, recovered paper is today the most important raw material for the production of paper, paperboard and corrugated board. The target by the year 2006 was at least 56% of paper and board products consumed in Europe to be recycled. Taking into account the expected increases in paper and board, recycled, this rate would be at least 25% higher than it is today. The prime objective of recovered paper recycling is to utilize the fibers contained in post-consumed recovered paper. Regarding disturbances in production, thermoplastic impurities (stickies) must especially be mentioned. Internal paper recycling (re-use of 'broke') describes the recycling of production waste within a paper mill with a processing line on site. An example is tissue and towel mills where paper goes directly from the paper machine to rewinders for the production of bathroom tissue or paper towelling. During this processing, adhesives are used for laminating, for the pick-up of the first sheet on the tube and for the end sheet tie down, and the waste, or 'broke', created here must be returned to the paper mill. Here, in general, only a relatively small amount of rejects are moved back into the paper production process. In contrast to adhesives that get into paper mills by external recycling and have sources varied and unknown, in internal recycling, there is only a relatively small amount of adhesive and the types used are known exactly. These mills normally do not have lavish sorting machines. As the additives added to the paper in production cannot be sorted out mechanically, most of the time the additives are required to be completely water-soluble or redispersible, even if this pollutes the process water with impurities. Adhesives that are used in this production are normally classified by the European Standard EN 1720 'Adhesives for Paper and Board Packaging and Disposal Sanitary Products Determination of Dispersibility' or by the American TAPPI standard UM 666 'Dispersibility Test for Adhesives'. Nowadays there are many adhesives that fulfill the requirements (Onusseit, 2006).

In the pulp and paper industries, environmental problems vary with both the size and category of the mill. In recent years, pulp and paper manufacturers have faced additional constraints to modernization, namely, raw water availability and limitations on wastewater discharge. Additional in-plant water conservation efforts are becoming necessary to reduce wastewater produced, which is highly contaminated with suspended particles, reduce the volume of effluents discharged and to minimize solid waste for disposal (Miner and Unwin, 1991). In recycling wasted paper mills, zero discharge is possible through wastewater re-use after suitable treatment. But due to poor or no wastewater treatment and old fiber recovery technologies, the industry is unable to recycle the effluent. The different processes in the plant were operated in an open circuit manner. Figure 15.12 shows the manufacturing processes, water usage and wastewater discharged. Two scenarios have been investigated: the first being the treatment of the end-of-pipe and the second being the control and management of pollution problems through the application of in-plant control and pollution prevention measures. Comparison between the two alternatives, based on a cost-benefit analysis and compliance with National Environmental Laws was done. From this study it was

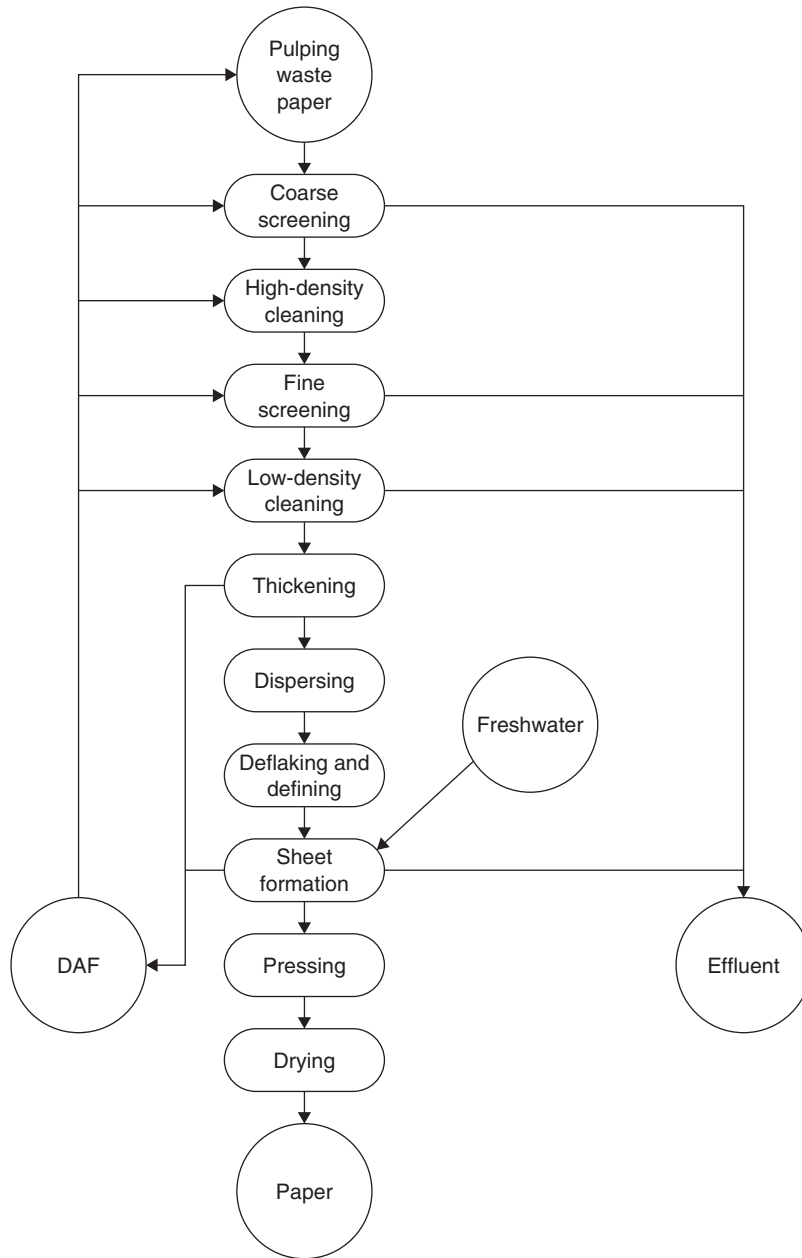

Figure 15.12 Process water usage and wastewater discharged from the board paper mill (adapted from Sohair *et al.*, 2006)

apparent that the implementation of the pollution prevention measures, such as the recovery of fiber, reduction of freshwater consumption and optimization of white water usage, proved to be very cost effective. All the implemented solutions have short payback periods and resulted in great savings compared with the treatment of the end-of-pipe (Sohair *et al.*, 2006).

The pulp and paper industry is responsible for large discharges of highly polluted effluents, whose main characteristics are the high toxicity and low biodegradability of their tannins, lignins, resins and chlorophenolic compounds. The composition of these effluents, which has a great influence on its treatability, may vary considerably, depending on the raw material and manufacturing process utilized (Sierra-Alvarez, 1990; Kortekaas *et al.*, 1998; Vidal *et al.*, 2001). Although aerobic treatment systems are the most widely used methods for treating effluents from pulp, the anaerobic process has been successfully applied in the treatment of non-toxic and easily biodegradable wastewaters from pulp and paper plants, such as the effluents from mechanical pulping, from paper recycling and from evaporator condensates. Buzzini and Pires (2007) evaluated the performance of an upflow anaerobic sludge blanket (UASB) reactor treating diluted black liquor from a Kraft pulp mill, which simulates an unbleached Kraft plant wastewater under different operational conditions, including partial recycling of the effluent. The reactor's performance was evaluated from the standpoint of COD, pH, volatile acid concentration, alkalinity, concentration of methane in the biogas and microbiological examinations of the sludge. Without recirculation, the reduction of the HRT from 36 to 30 h did not significantly affect the average COD removal efficiency. The average volatile acids concentration in the effluent increased by 16%. The average COD removal efficiency varied from 80 to 86% (without recirculation) and from 7% to 78% with recirculation but, in this latter case, the hydraulic retention time was 30 and 24 h, while without recirculation the HRT was 36 h. Thus it can be considered that, under the tested conditions applied in this work, the partial recycle of the effluent did not improve the COD removal efficiency. However, it allowed operating the reactor with lower hydraulic retention time without disintegration of the granules. For the wastewater used in this research and under operational conditions of this work the partial recirculation of the effluent caused the average COD removal efficiency to drop from $80 \pm 1\%$ to $75 \pm 2\%$ for an HRT equal to 30 h. However, when the HRT was reduced from 30 to 24 h, the average COD removal efficiency increased from $75 \pm 2\%$ to $78 \pm 0.3\%$. The effluent alkalinity was always higher than the influent one, even though the loading rate increased, which indicated that the anaerobic metabolism produced alkalinity. When the recirculation was applied, the average effluent alkalinity showed an increase. The concentration of volatile acids in the effluent was lower than the influent concentration in all cases. The reactor presented stable operation even when some granule flotation appeared. After 83 days of operation, it was observed that the floating granules were hollow in the center. However, after 180 days these hollow granules were no longer observed either in the sludge blanket or in the few granules that reached the reactor surface.

Life cycle impact assessment (LCIA) was combined with economic analysis of social life cycle costs (SLCC) to investigate five alternatives for newspaper waste management (Dahlbo *et al.*, 2007). The alternatives consisted of various recovery and treatment methods applicable to newspaper in a separately collected paper fraction and to newspaper in mixed waste. LCIA and SLCC were linked to each other at three different stages. First, LCIA was used to rank alternatives and asked how this ranking related to the SLCC associated with each alternative. Second, the cost minimizing problem was solved and asked how this purely economic ranking related to LCIA

ranking. Third, the cost minimizing problem was solved when external costs from the use of fossil fuels were included and then compared the solution to the LCIA results. All of the comparisons between the environmental and economic impacts of the case study clearly show that including both of these two dimensions in the assessment of waste management alternatives is crucial for making sustainable decisions. The results of the two assessments appear, however, to rank the alternatives in exactly reverse order. Concentrating solely on the economic aspects seems to lead to the environmentally worst alternatives. On the other hand again, the environmentally best solution results in highest costs. The LCIA results support energy recovery if the produced energy replaces energy from fossil fuels, thus earning credits from avoided impacts. Otherwise recycling newspaper for paper production outperforms energy recovery. The differences between energy recovery and material recycling turned out to be relatively small, however. Therefore, SLCC provides an important additional qualification: burning separately collected newspaper is always far more expensive than material recovery for paper production. In addition to economic grounds, credits from biodiversity benefits from replaced harvests reinforce the advantages of newspaper recycling.

A new process for the incorporation of old newspaper fibers into polyolefins, such as LDPE, HDPE and PP, was developed by Baroulaki *et al.* (2006) based on the dispersion of paper fibers in a hot polymer solution and the subsequent precipitation of the polyolefins by cooling, which produces a slurry of polymer with paper fibers (Figure 15.13). The technique studied in this work was an alternative to the conventional melt compounding and was expected to provide efficient wetting of fibers by the polymer. The density, hardness and tensile properties of composite specimens prepared by compression molding, with filler content ranging from 10% to 40% (w/w), were measured. The tensile strength of HDPE and PP composites presents a slight decrease at filler concentrations between 10% and 20%, followed by considerable decrease in the range of 30–40%. On the other hand, the modulus of elasticity did not display a clear dependence on filler content. Composites based on LDPE exhibited good retention of tensile strength especially at low filler content, whereas their modulus of elasticity at 40% fiber concentration increased by 78%.

Asha Poorna and Prema (2007) optimized the culture condition for the enhanced production of extracellular thermostable cellulase-free xylanase from *Bacillus pumilus* by solid-state fermentation. Batch studies were carried out to evaluate various agro-industrial residues such as rice bran, rice husk, rice straw, sawdust, coconut pith, sugarcane bagasse and wheat bran for enzyme production by the bacterial culture. The endoxylanase production was highest on wheat bran media (5582 U/gds), which enhanced 3.8-fold (21 431 U/gds) by optimization of cultivation conditions. The enzymatic extracts were used in mixed wastepaper recycling, which resulted in a considerable improvement of the paper strength with high drainage and easy drying up. The results of enzyme application with recycled paper clearly indicated that the effective use of enzymes in fiber separation could reduce the cost of carton paper production from 25 to 50% of total production cost. This increase in yield and decrease in production cost is a promising methodology for hyper-production of alkaline thermostable xylanase. The results of enzyme application with recycled paper clearly indicate that the effective use of enzymes in fiber separation can substantially reduce

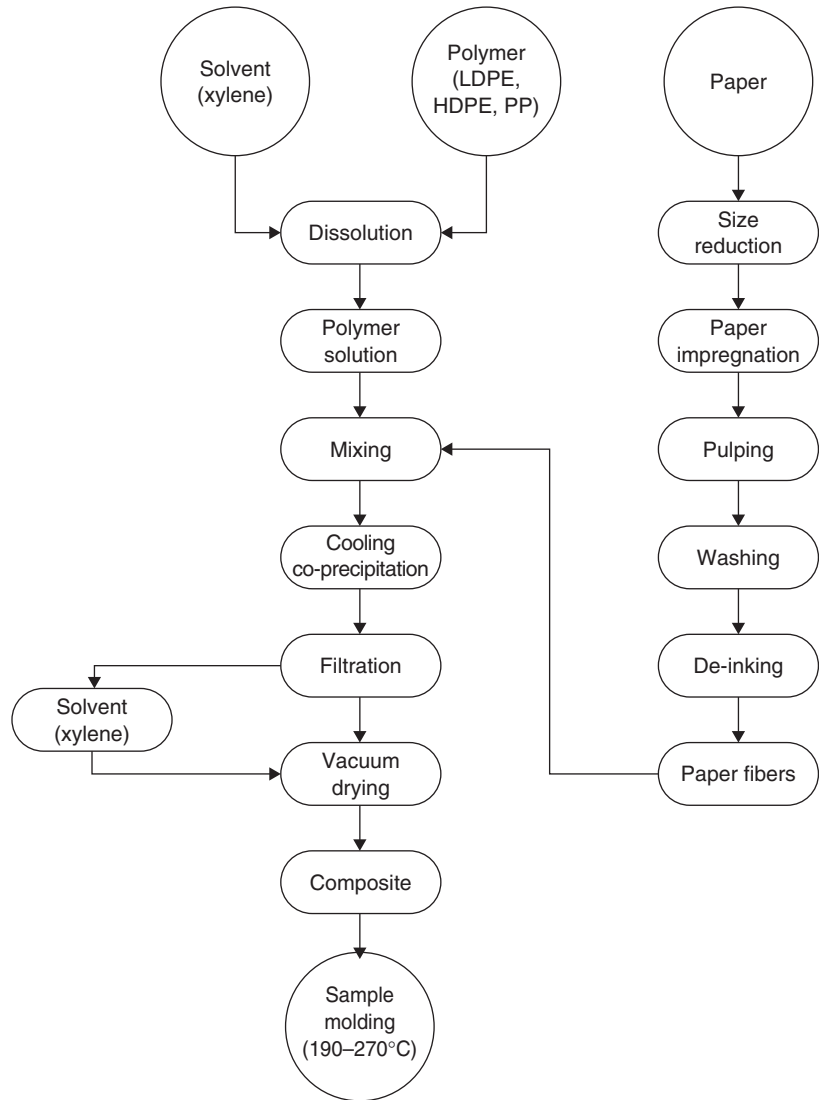

Figure 15.13 Polyolefin/newspaper fiber composites preparation and characterization flowsheet (adapted from Baroulaki *et al.*, 2006)

the cost of carton paper production and is a promising alternative in the present scenario of biobleaching of Kraft pulp.

Polymers

Biodegradable synthetic copolymers and composites

The continuously increasing extent of pollution of the environment has recently given rise to demands for novel biodegradable polymers, mainly for applications related to

food packaging and agriculture (Schnabel, 1981; Huang, 1985; Kumar, 1987). The main emphasis initially was focused on the synthesis of novel aliphatic polyesters (Schnabel, 1981; Chiellini and Solaro, 1992; Vert *et al.*, 1992) due to their higher susceptibility to biodegradation with regard to other polymers such as polyamides and polyanhydrides (Zhang *et al.*, 1993; Satyanarayana and Chatterji, 1993). Among the aliphatic polyesters, poly (ϵ -caprolactone) (PCL) (Tokiwa *et al.*, 1983, 1988), poly (β -methyl- δ -valerolactone) (Nakayama *et al.*, 1993, 1995), polylactide (Kim *et al.*, 1992, 1993; Vert *et al.*, 1992; Satyanarayana and Chatterji, 1993) and their copolymers (Den Dunnen *et al.*, 1993; Gaymans and de Haan, 1993; Shiaw *et al.*, 1994) have been suggested as the most promising polymers in terms of potential applications. Low glass transitions and low melting points of most polyesters have oriented several researchers toward exploring other potential avenues, such as the direct polymerization of α -amino acids (Wu, 1992; Kiyotsukuri *et al.*, 1992; Yang *et al.*, 1993) or copolymerization of lactams with lactones (Goodman, 1984; Goodman and Valavanidis, 1984; Goodman and Vachon, 1984a, b) in an attempt to synthesize novel polymers with higher thermal resistance. The biodegradability tests conducted on the copolyesteramides were highly promising and in favor of potential applications (Huang, 1985; Kumar, 1987). However, the difficulties encountered in producing high molar mass and environmentally degradable copolyamides have been the restrictive factors, in terms of applications, for the copolyamides (Yang *et al.*, 1993; Chen *et al.*, 1993; Bera and Jedlinski, 1993).

Novel biodegradable copolyamides based on diacids, diamines and α -amino acids

The novel copolyamides, based on adipic acid (AA), 1,6-hexane diamine (1,6-HD), isophorone diamine (IPD), bis(para-aminocyclohexyl)-methane (PACM-20), and various α -amino acids (L-tyrosine, proline, alanine, glycine, glutamic acid), were synthesized with a two-stage melt polycondensation (100°C and 250°C for 1 and 2 h, respectively). The semicrystalline and, occasionally, amorphous nature of copolyamides based on the salt of 1,6-HD/AA (1:1 mol/mol)/ α -amino acids were shown with wide-angle X-ray diffraction. Several biodegradability experiments (burial in soil, alkali and enzymatic hydrolysis) were carried out for testing the susceptibility of these polymers to degradation. The physical properties of the copolymers were investigated before and after biodegradability testing. The observed gradual increase in X_c of the NaOH-insoluble fraction of the copolyamides was proportional to their exposure to alkali hydrolysis. It is thought that the initial gradual dissolution of the amorphous parts results in higher crystallinity values, similar to what has been reported for the early stages of *in vivo* and *in vitro* degradation of poly-(L-lactide) (PLLC), polyglycolide (Chu, 1981) and PCL (Pitt *et al.*, 1981). The degradation process of biodegradable polymers occurs in two stages. In the first stage, the chain scission occurs preferentially in the amorphous regions of the semicrystalline polymer. The initially random chain scissions result in a decrease of the degree of entanglement, thus facilitating and even considerably promoting the mobility of non-degradable chain segments in these regions. The mobility promotes crystallization, as reflected by the high X_c values. However, following dissolution of the amorphous regions, the degradation proceeds to the crystalline regions. A substantial decrease in the molar masses of the copolymers was

recorded when the copolymer were exposed to NaOH (10% wt/vol NaOH, 80°C) (Arvanitoyannis *et al.*, 1993, 1994, 1995). The effect of alkali hydrolysis was very pronounced for the copolymers rich in α -amino acids because they underwent a significant reduction in the molar mass of polymeric chains, thus resulting in number average molecular weights M_n as low as 2100. Tensile strength and tensile modulus of copolyamides were shown to undergo a sharp decrease after the copolymer samples were treated with alkali solutions for more than 20 h. In fact, a linear dependence of tensile strength on the M_n with regard to the exposure time of alkali hydrolysis was established. The molar mass of copolyamides was not substantially affected when the copolyamides were buried in soil. Overall, when the content of α -amino acids was higher than 15% in the copolyamides, they turned from semicrystalline to amorphous according to the DTA and WAXD measurements. The potential degradability of the synthesized copolyamides was confirmed by various biodegradability experiments, such as alkali hydrolysis, microbial-bacterial attack (burial in soil) and enzymatic hydrolysis. It is envisaged that these copolyamides may find various applications because of their enhanced susceptibility to biodegradation.

Novel biodegradable copolyesteramides from ϵ -caprolactone and various nylon salts

The biodegradation of synthetic polymers is of considerable interest to environmentalists, industrialists and academic researchers as well (Chen *et al.*, 1993). Aliphatic polyesters have been long considered as the most promising polymers for applications in which biodegradability is a prerequisite (Vert *et al.*, 1992; Kim *et al.*, 1992, 1993; Satyanarayana and Chaterji, 1993). On the other hand, synthetic poly(amino acids) and polyamides, though regarded as the analogs of proteins and natural peptides, have not yet found the extent of expected applications, mainly because of preparation difficulties (Huang, 1985; Yang *et al.*, 1993). The aliphatic copolyesteramides recently have been suggested and partially investigated as a polymer family with much potential concerning functional performance and susceptibility to degradation (Goodman and Sheahan, 1990a, b; Arvanitoyannis *et al.*, 1994, 1995). Synthesis of copolyesteramides has been carried out following a three-stage process: 1.6-HD was mixed with a diacid (AA, sebacic acid [SA], or octadecanedioic acid [ODA]) and ϵ -caprolactone (ϵ -CL) and was kept at 120, 180 and 250°C for 2 h, 2 h and 0.5 h, respectively (Arvanitoyannis *et al.*, 1994, 1995). Although the melting points T_m versus ϵ -CL content showed eutectic curves (minimum at 20/20/60 for SA, ODA, or AA/1.6-HD/ ϵ -CL), similar to other copolymers (Kehayoglou and Arvanitoyannis, 1990), the melting points versus the ϵ -CL content were found to give straight lines (Arvanitoyannis *et al.*, 1994, 1995). The substantial difference in the heat of fusion between the ester-rich and the amide-rich copolymers possibly could be attributed to the incompatibility of crystal structures (monoclinic or triclinic for nylons in contrast to the orthorhombic for PCL) (Arvanitoyannis *et al.*, 1994). An increase in ϵ -CL content resulted in broadening of peaks and in decreasing the T_m and T_g values due to the higher flexibility of the polymeric chain imparted by the incorporation of ϵ -CL. The total organic carbon (TOC) measurements indicated that only the ester-rich copolyesteramides (>50% ester content) could be considered biodegradable because the TOC values for the amide-rich

copolyesteramides were very low (Arvanitoyannis *et al.*, 1994, 1995). It was also found that the weight loss percentages of the copolyesteramides after their immersion in alkali solution increased with an increase in ϵ -CL content. The weight loss rate was greatly enhanced after the first 10 h, reaching up to about 50% (after 30 h exposure) and was accompanied by a substantial decrease in M_n , as determined by GPC. Enzymatic hydrolysis was also conducted for studying the degradation products. Nuclear magnetic resonance analysis (NMR) of the degradation products showed that cleavage primarily occurs at ϵ -CL- ϵ -CL labile bonds in the polymer backbone, whereas the amide bonds (O=C-NH-) are characterized by low susceptibility to degradation. The thermal properties (T_g , T_m) showed a linear decrease against the CL content, while the TOC considerably increased. Enzymatic and alkali hydrolysis, as well as burial in soil experiments, agreed that an increase in CL content reflected an increase in the susceptibility of copolyesteramides to biodegradation.

Novel star-shaped copolyactides

Strong interest in the eventual, and preferably rapid, biodegradation of synthetic polymers has developed only in past years, primarily in response to the growing problem of waste disposal of plastics (Lenz, 1993). Polyesters attracted much research interest in view of their satisfactory performance property wise and their inherent biodegradability. PCL and PLLA were the most responsive to biodegradation both *in vitro* and *in vivo* (Nishida and Tokiwa, 1992, 1993a, b; Reeve *et al.*, 1994). Apart from these two homopolymers (PCL and PLLA), several copolymers, based on these two components, have been synthesized in an attempt to 'tailor' the properties of the homopolymers for special applications (Kricheldorf *et al.*, 1988; Zhang *et al.*, 1993; Mikos *et al.*, 1993). A successful shaping *in-situ* process has been the main incentive for the introduction of a soft segment such as poly(ethylene glycol) in PLLA (Kobayashi *et al.*, 1991; Cerrai and Tricoli, 1993). The difficulties encountered in processing PLLA remained the major limiting factor in applications despite the well-accepted biocompatibility and biodegradability of PLLA (Leenslag, 1984; Kim *et al.*, 1992, 1993). Novel branched star-shaped polymers are envisaged as a potential solution to the processing problem because they can combine high molecular weight with lower melt viscosities than the linear PLLA (Aragade and Peppas, 1993; Gijpa and Pennings, 1994a, b). The polymerization of L-lactide (LLA) with polyol (i.e. pentaerythritol, glycerol or sorbitol) was carried out in the presence of two catalysts (stannous octoate [Sn, oct], tetraphenyl tin [TPhT]) at 130°C for 4 day (Arvanitoyannis *et al.*, 1995, 1995, 1996). The GPC traces of the LLA/GL or LLA/pentaerythritol copolyesters (synthesized with Sn octoate) gave monodisperse curves, thus favoring the occurrence of only one mechanism. In contrast, the bimodal GPC traces, recorded when TPhT was used as the catalyst, support the previously expressed suggestion that two mechanisms are in action, one initiated by the polyol and the other via the catalyst. The DSC results (bimodal traces) further support the suggestion for two mechanisms. The degradation rates of these polyesters were studied by enzymatic and alkali hydrolysis, primarily in terms of changes in weight, M_n , and TOC. NMR analysis of degraded products confirmed the suggested cleavage of hydrolyzable bonds of

star-shaped PLLA. High polyol contents strongly favored extensive cleavage of polymeric chains, thus resulting in an increase of crystallinity. It is noteworthy that the theoretical capability of polyols to act as cross-linking agents was not confirmed by solubility experiments on the synthesized copolyesters (Arvanitoyannis *et al.*, 1995, 1996).

Biodegradable composite materials

The development of novel polymeric materials that degrade slowly is considered a very important research area, especially in view of their various current and potential applications as environmentally degradable materials (Storey and Shoemake, 1993; Albertsson *et al.*, 1994). Although D, L- or L-lactide and ϵ -CL seem to be the most popular monomers, especially in the field of polymeric composite materials (Li *et al.*, 1990a, b, c) mainly related to medical applications, polyamides are another promising class of polymer that appeals to a wider range of applications (Consalves *et al.*, 1993). It is anticipated that these novel thermoplastic materials have a lot of potential because of their inherent advantages over the majority of thermoset materials (Arvanitoyannis and Psomiadou, 1994) namely, control of their percentage crystallinity (physicochemical properties), ease of processing and 'friendliness' to the environment (Arvanitoyannis *et al.*, 1995). Composites, consisting of AA/1.6HD/L-proline or L-glycine and short E-glass fibers, were prepared by the hand lay-up method (Srivastava and Lal, 1991). The crystallinity of the copolyamide matrix was determined from WAXD following the generally accepted procedure for constructing the diffraction pattern of a composite material. Determination of percentage of crystallinity in composite materials with DTA is complicated by the occurrence of nucleation fronts on the glass fibers, in addition to the statistical nucleation from the melt, known as transcrySTALLINITY. Therefore, occurrence of multiple melting peaks should be attributed to different spherulite morphologies (Arvanitoyannis and Psomiadou, 1994). Detection of void content is very critical in terms of determining the shelf-life and performance of the composite material. The main reasons for the occurrence of voids in the degradable composite materials are the following: entrapment of air within pelletized material, residual moisture and shrinkage volume of the core region.

Natural-synthetic polymer blends

It has been estimated that approximately 2% of all plastics (mostly non-degradable) eventually end up in the environment, thus contributing considerably to the currently acute ecological problem. The current trend toward protection of the environment is expressed by using degradable polymers and composting or recycling the 'recalcitrant' polymers. Blends of natural and synthetic polymers have been considered a promising avenue for preparing polymers with 'tailor-made' properties (functional physical properties and biodegradability).

Partially degradable blends

Starch-based plastics initially attracted some research interest, but their development was not as expected, mainly because of their inadequacy with regard to mechanical properties and water transmission (Otey *et al.*, 1974; Giffin, 1994). In an attempt to

overcome this problem, synthetic polymers/starch blends were investigated (Shogen, 1993; Lawton and Fanta, 1994). The main advantages of these blends could be summarized as follows (Scott and Gilead, 1995):

- 1 property tailoring by proper selection of components and their ratios
- 2 lower cost by using blending (i.e. extrusion, casting) instead of synthetic
- 3 routes for production of novel materials
- 4 ecological factors (environmentally friendly and usage of plastic wastes).

Mixtures of low-density polyethylene (LDPE) with gelatinized potato, rice, wheat and soluble starch, with or without ethylene acrylic acid (EAA) as a compatibilizer, were extruded in the presence of 15–20% water. As long as the starch content in the blends does not exceed 20%, the mechanical properties of the LDPE/starch blends still lie within the operational limits. Typical scanning electron microscopy (SEM) micrographs taken after fracture clearly showed the blend morphology and the distribution of each component (Psomiadou *et al.*, 1998). The wheat starch particles are deformed and interspersed within the LDPE matrix. Although in several previous publications the failure modes of PE were investigated and analyzed, a tentative failure mechanism of PE/starch blends was only recently put forward (Arvanitoyannis *et al.*, 1997, 1998). Brittleness and ductility are the two main failure modes. Whichever of these two prevails depends not only on the deformation features and fast or slow crack growth (Stojmirovic *et al.*, 1992; Chudnovsky *et al.*, 1995), but also on conditioning of the sample over certain relative humidity environments. Therefore, the ensuing plasticization of the LDPE/starch blends could be due to penetration of water and filling of voids. Constructing a tentative micromechanical model to depict the geometries, arrangements and interactions of components within a composite material has always been a challenging task (Christensen, 1979). The main difficulties arise from inherent strength variations within the mass of the composite systems and the need for long-term predictions concerning the performance of the composite in terms of the mechanical properties. Although a previously described system (Reifsnider, 1994) was initially suggested for fiber-matrix composite materials, it could possibly be applied in the case of LDPE/EAA/wheat starch composites as well. According to this model, deformed starch particles constitute the core material which is surrounded by an LDPE/EAA continuous matrix. Depending on the relative distribution of the EAA, regions of LDPE/starch/EAA vary in their plasticity; a high EAA content promotes greater plasticity in the matrix, while in regions of lower EAA content, debonding and slipping may occur at the matrix/starch particle interface.

Both LDPE and HDPE were thoroughly investigated with regard to their gas permeability (GP) (Yasuda and Stannett, 1962; Van Krevelen, 1990) because of their extensive use in food packaging applications. LDPE is a semi-crystalline polymer of both amorphous (intralamellar, interlamellar and interspherulitic) and crystalline (ribbon-like lamellae) areas (Michaels and Bixler, 1961). The presence of starch particulates as fillers within the LDPE matrix, apart from disturbing the continuity of the LDPE network and contributing to the inhomogeneity of the system, enhances substantially the GP of the LDPE/starch composite structure because of their strong hydrophilic

character. The water is either strongly bound (0–12%) or is capillary moisture (12–30%). The temperature dependence of GP and gas diffusion (GD) of the blends is described by the well-known Arrhenius equations.

At this point, it is worth emphasizing the importance of the activation energy of diffusion because of its involvement in chain separation, which is necessary for the eventual ‘loosening’ of the structure. Certainly, the incorporation of starch particles disrupts the LDPE network by imparting some flexibility and mobility and thus reducing the required energy per unit chain separation. An increase in temperature enhances even more the cavity and channel formation, thereby facilitating the diffusivity and permeability. The diffusion and the permeation activation energies were found to fall in the following order with regard to the permeating gas: $ED(N_2) < ED(O_2) < ED(CO_2)$. This order is in agreement with other reports, assuming that there is no interaction between the permeant gas and the matrix (LDPE/starch). LDPE/starch blends have been commercially used for the past 15–20 years. The generally accepted degradation scheme of a high molar mass polymer consists of the following stages:

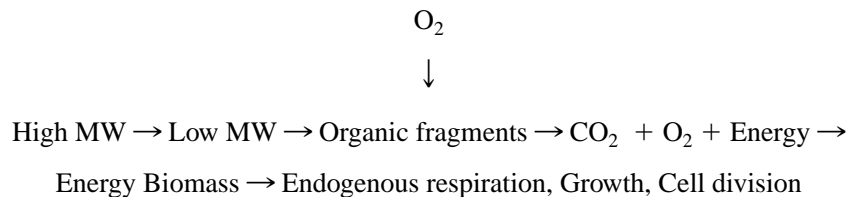

Both soil burial and bioreactor exposure experiments showed a decrease in percentage elongation and considerable weight loss, which could be described as a two-stage process (Krupp and Jewell, 1992). The first stage consists of partial starch removal and only at a later stage does a slow rate of degradation of LDPE occur. Most investigations of LDPE advocate enzymatic oxidation, dehydrogenation and carbon-carbon breaking processes as the predominant degradation mechanisms of LDPE (Albertsson and Ranby, 1979; Albertsson *et al.*, 1994; Albertsson and Karlsson, 1994). However, the biodegradation rate of LDPE/starch blends can be effectively accelerated only if the starch content is higher than 10%. Similar conclusions were also reached by other researchers (Gould *et al.*, 1990; Narayan, 1991; Goheen and Wool, 1991; Wool, 1995) who, in addition, applied the percolation theory (Stauffer, 1985) assisted by computer simulation (Peanasky *et al.*, 1991). In general, the higher the starch content, the worse the performance of the composite materials will be (lower tensile strength and modulus, higher GP and water vapor transmission rate), but the higher their biodegradability. An increase in moisture or EAA (whenever used) content of these composite materials induced plasticization of the samples. The degradability of LDPE/starch blends was confirmed by weight loss measurements and changes in mechanical properties.

Chitosan-poly (vinyl alcohol) blends

Poly(vinyl alcohol) (PVA) can be prepared by hydrolysis of a variety of poly(vinyl esters) and poly(vinyl ethers) and has many applications in pharmaceuticals, cosmetics and

the paper and food industries, either alone or in blends with other polymers, such as poly(3-hydroxy butyrate) (Azuma *et al.*, 1992), polyacrylic acid (Daniliuc and David, 1996), β -chitin (Lee *et al.*, 1996) and cellulose (Hasegawa *et al.*, 1992a, b, 1994), among others. Chitosan is the deacetylated product of chitin. Next to cellulose, chitin is the second most abundant polysaccharide in nature (Rathke and Hudson, 1994). Chitin is associated with other polysaccharides in fungal cell walls, while in animal forms, chitin is associated with proteins (Muzzarelli, 1977). The production of chitin is possible primarily as a secondary activity related to the marine food industry (Zikakis, 1984). Chitosan has been used in a very wide range of applications, such as prevention of water pollution by chelating heavy metals or radioactive isotopes, in membrane separation (Aiba *et al.*, 1986), in medicine and biotechnology and in the food areas, either as a food packaging material because of its antimicrobial action or as dietary fiber and a potential medicine against hypertension thanks to its scavenging action for chloride ions (Furda and Brine, 1990; Ishikura, 1993; Okuda, 1995; Muzzarelli, 1996). The preparation of chitosan/PVA blends was carried out as follows. The PVA solution was added, under vigorous stirring and heating, to the chitosan solution and then the plasticizer was added and mixed into the solution for 10–15 min until dispersed. Then the solution was cast over plexiglass plates. Low molecular weight compounds added to chitosan/PVA blends are shown to lower the melting point and the glass transition T_g . Wide-angle X-ray diffraction patterns (WAXDP) showed that PVA has a high percentage crystallinity ($X_c \sim 54\%$). The observed reduction in percentage crystallinity in chitosan/PVA blends should be due to 'crystallization disturbance' of chitosan in the blend state.

Landfill

Landfill has served mankind for much longer than any alternative disposal option. Landfilling is defined as the disposal, compression and embankment fill of waste at appropriate sites. Landfill for the moment is easy, adjustable with lower cost than the rest of disposal methods and stands alone as the only all waste material disposal method (Karakasidis, 1997; Clarke *et al.*, 1999). Although landfill was traditionally selected by many communities because of its low cost, it has become prohibitively expensive. The costs of landfill rose, due to the decreasing number of landfill sites and the more sophisticated techniques and operating practices (Von Schoenberg, 1995; Adams *et al.*, 1996). Important factors that need to be taken into account for the correct function of the disposal sites are the selection of the site, the design and organization of the site, the operating performance and the life cycle and biodegradability of the wastes (Karakasidis, 1997). The environmental impact of waste landfilling depends on the design and operational mode of the landfill facility and the nature of the waste deposited (Dascalopoulos *et al.*, 1998). The landfill gas generated at landfill sites was considered barely controllable and one of the main disadvantages of this method. However, the production of such gas has recently been perceived as a promising source for highly combustible fuel since it is a clean source of fuel (Von Schoenberg, 1995; Clarke *et al.*, 1999).

In order to comply with the EU ELV Directive, an increase in the recycling rate of automobiles to 80% by 2006 and 85% by 2015, must be met (EC, 2000). On average,

the plastic content of a car was 9% (ACORD, 2000) and the average thermoplastic content is about 45% polyolefin (40% PP, 4–6% PE). The properties of a blow-molded bottle prepared from 100% post-consumer high-density polyethylene (HDPE) showed that this recycled polymer exceeded the materials specifications for virgin plastic designs. Similarly, a sample of thermoplastic polyolefin (TPO, 100% polypropylene), obtained entirely from shredder residue (SR) displayed sufficient material strength for future separation and reprocessing (Ambrose *et al.*, 2002).

Incineration

An alternative method of waste disposal to landfill is waste incineration. Waste incinerators use the process of combustion to convert the waste materials into carbon dioxide and water. Incineration residues usually are small quantities of HCl, S and other volatile compounds and ash (Waite, 1995). However, it is obvious that not all household waste materials are combustible. Reduction of waste volume by 80–90% is achieved with incineration. Therefore, it should be considered as a means of reducing the amount of waste to be disposed of by landfill rather than a method of ultimate disposal on its own (Von Schoenberg, 1995).

Combustion can be regarded either as a pretreatment method for the waste prior to its final disposal or as a means for increasing value to waste by energy recovery (Dascalopoulos *et al.*, 1998). Incineration became an increasingly popular method of waste disposal treatment by the beginning of the 1970s when many incinerators were constructed (Waite, 1995). The effect of polymers on the combustion of MSW has not been satisfactorily assessed in the past. The Association of Polymer Manufacturers in Europe (APME), in conjunction with academia, launched an in-depth program aimed at understanding the role of polymers in MSW combustors. The program of APME on energy recovery from used plastics is focused on exploring all technically different means (Mark, 1995). Co-combustion is regarded as one of the most promising means for economic and safety reasons. As a result, conversion of polyurethanes together with other materials such as textiles, wood, paper and other plastics into energy in 'state of art' incinerators, which meet all health and safety requirements and the respective legislative regulations for emissions and environmental standards, would be now and in the future an important process contributing to the economy and environment (Bastian *et al.*, 1995). Waste combustion with energy recovery is usually cost effective only in large, heavily populated metropolitan areas. This approach becomes less appealing with low fossil fuel cost, strong markets for paper and the necessity for disposing of a substantial volume of residue, a part of which may be hazardous (Mark, 1995). However, the main problems to be addressed prior to extensive utilization of this method are the finite risk of contamination, noise, odor, fire and explosion hazards, vegetation damage, ground water pollution and air pollution (El-Fadel *et al.*, 1997). The consumption of crude oil, natural gas and pit coal, normally used in district heating plants, can be substantially lowered by the incineration of plastic waste. Assuming that the efficiency of an incineration plant and a district heating plant is the same (80%), the incineration of 1 kg LDPE releases 43.3 MJ which correspond to 0.08 kg crude oil, 0.07 kg natural gas and 0.25 kg pit coal (Molgaard, 1995). The cost

for landfill or incineration varies in different countries as well as the treatment routes employed by different European nations (Simons *et al.*, 1995; Morris *et al.*, 1998; Palin and Whiting, 1998).

Pyrolysis

High molecular weight substances cannot be purified by physical processes like distillation, extraction or crystallization. They can only be recycled by pyrolysis of their macromolecules into smaller fragments. Pyrolysis can be used to convert mixed plastic wastes to oil products, combustible gas and heavy residues. The pyrolysis products may then be suitable for common petrochemical separation processes. Pyrolysis is the thermal degradation of macromolecules in the absence of air and generates oils and gases, which are suited for chemical utilization or generation of energy. In fact, the pyrolysis products consist of 34% ethylene, 9% propane, 39.7% oil (mainly aromatic compounds) and 1.7% residue (Kaminsky, 1995; Faaij *et al.*, 1998).

The Constantinople composting and recycling plant, constructed in 2001, is one of the few composting plants in Turkey. During test operations of the plant, it was reported that the weight of the oversize materials (OM) above an 80-mm sieve was about 40% of the total incoming waste. They mainly consist of plastic bags that were full of garbage, which resulted in operational problems in the plant. In a study, the composition of OM was determined and evaluated, particularly to find the economic losses in the plant. It was determined that approximately 58% of the OM transferred to the landfill area due to operational failures and interruptions could be used at the plant with improved operational conditions. Otherwise, the plant would realize an annual economic loss of about 640 800 US\$. Compost quality in the plant has been satisfactory, but source separated collection, at least the separation of the wet from the dry fraction, is needed to increase the amount of compost and recovered materials. To increase the amount of compost and captured recyclable materials in the plant in Constantinople, all plastic garbage bags should be torn in the first step of the process. However, appropriate waste collection (higher organic and recyclable content) from potential districts of the city is still an important factor for the plant. The best way to improve the situation would be source separated collection, at least the separation of the wet from dry fractions. In Turkey and some other developing countries, it is difficult to operate plants optimally, especially publicly owned plants, due to investment and administrative problems. The most important inadequacy in any environmental management activity in those countries is the operating problems and lack of research during operation of the plants (Kanat *et al.*, 2006).

The thermal decomposition of polyalkenes was investigated as a recycling route for the production of petrochemical feedstock. Low-density polyethylene (LDPE) and polypropylene (PP) were thermally decomposed individually in a batch reactor at 450°C, thus forming oil/wax products. Then these products were dissolved in primary heavy naphtha to obtain steam cracking feedstock. The selectivity and kinetics of copyrolysis for 10 mass% solutions of oil/waxes from LDPE or PP with naphtha in the temperature range from 740 to 820°C at residence times from 0.09 to 0.54 s were

studied. The decomposition of polyalkene oil/waxes during copyrolysis was confirmed. It was shown that the yields of the desired alkenes (ethene, propene), according to polymer type, increased or only slightly decreased compared to the yields from naphtha. In addition to the primary reactions, the secondary reactions leading to coke formation were also studied. The formation of coke during copyrolysis of LDPE wax with naphtha was comparable to the coking of pure naphtha. Slightly higher formation of coke was obtained at PP wax solution at the beginning of the measurements, on the clean surface of the reactor. After a thin layer of coke covered the walls, the production was the same as that from naphtha. The results confirmed the possibility of polyalkenes recycling via the copyrolysis of polyalkene oils and waxes with conventional liquid steam cracking feedstocks on already existing industrial ethylene units (Hajekova and Bajus, 2005). The results obtained proved that the oil/wax fractions obtained from the thermal decomposition of polyalkenes at mild conditions can be added to liquid charges for steam cracking in the amount of 10 mass%. It is not necessary to separate the oil and wax fractions from each other at this level of allowance. The separation would unnecessarily increase the costs for preparing these raw materials. The gases formed on the decomposition of polyalkenes can be burnt, but in the case of fluid cracking of polyalkenes, they can be returned to the process as fluidizing gas. They can also be added to the streams of gases that are formed at the steam cracking unit and thus the already existing equipment for separation of gases from steam cracking can be utilized. The solution that has a 10 mass% concentration of oil/waxes does not cause any problems on spreading. Slightly warming up the raw material in the tank is sufficient.

Re-use and recovery

One of the priorities set in most countries over the world is drastic waste reduction. Where waste cannot be avoided, it must be recovered, preferably in an environmentally friendly way. This simply means recover and reuse something after its initial function has expired. The ways that the recovered material can be used may be similar or dissimilar to the original function (Lemann, 1995). The number of strategies identified to help waste prevention includes material life extension, process management and reduction of material used (Bergner, 1995). The term re-use expresses the identification of the most cost-effective avenue in reusing goods, components and materials. When a product is designed, the requirements of re-use and collection process need to be taken into account (Stahel, 1995). Moreover, the recovery and re-use of waste must not result in an enrichment of hazardous substances within the substance life cycle. All plastic materials interact with 'products' to a certain extent. This interaction can either be superficial or more extensive, followed by absorption into the body of the plastic. Contamination of refillable containers through migration of substances (i.e. dyes, flavors) into the plastic could occur at various times of the material shelf-life. Although these substances may not be affected by the washing process, they might subsequently be released into the food on their re-use, with serious implications regarding both consumer safety and sensory characteristics of food.

A plastic container is suitable for refilling when it is resistant to the uptake of chemical and microbiological (toxicological) hazards and taints. Exposure to chronic toxins is statistically unlikely to occur with contaminated containers, but a single exposure at a high level could be a major issue (Castle, 1994).

Composting

Municipal solid waste composting is an alternative to the disposal of wastes that attracted interest in the USA and Europe. A study on composting in the USA lists 15 facilities that are currently operational and an additional 23 that are under construction, or at planning or designing stages. In Europe, composting facilities are operational or under construction in France, Holland, Switzerland, Italy, Greece and Spain (Renkow and Rubin, 1998). Composting has been officially recognized as a form of recycling and is expected to play an even more important role in future waste management operations. Although composting has been rapidly gaining importance, the development of the technology still relies on practical experience. Composting still has to grow from an art to a well-established technology. Composting refers to a self-heating, aerobic process of organic wastes and other industrial organic compounds in order to convert them to a mature and plant compatible substrate. If a material is considered compostable, biodeterioration/biodegradation should transform it into compost (Tokiwa *et al.*, 1989; Narayan and Snook, 1994; Raschle *et al.*, 1995; Blanc *et al.*, 1995). Under optimal degradative conditions, a controlled composting process could be completed within 3 months, while under normal conditions within 1 to 2 years (Kaiser *et al.*, 1995). The final product of composting is rich in organic matter but its concentration of key nutrients, usually too low for competing with commercial fertilizers, improves the soil structure through its enrichment with humic substances (Marilley *et al.*, 1995; Masters, 1998). Besides the microflora required for composting, composts can also harbor potentially pathogenic and/or allergenic bacteria and molds like *Aspergillus fumigatus* (Lott Fischer *et al.*, 1995). The aim of the composting operation is to obtain, preferably in the short term against limited cost, compost with a desired product quality. All composting operations should take place under controlled, environmentally safe conditions. During the process, gas and heat may be released that can be used for energy recovery while, at the same time, volume reduction of the original material up to 40% can be achieved. Furthermore, the process is considered to be 'environmentally friendly' and financially viable, but only under proper guidance and management. The basic reaction of the composting process is the oxidation of organic matter with oxygen to carbon dioxide and water by employing thermophilic microorganisms. Under normal temperature conditions (i.e. room temperature), chemical oxidation plays a minor role. At the same time, there is a release of heat resulting in a temperature increase within the composting matter. The process requires a blend of materials with appropriate physical and chemical properties and pertinent management to ensure that suitable process conditions are maintained. The process takes place at temperatures sufficiently high for destroying pathogens. Municipal solid waste composting treats all readily degradable components of the waste stream such as paper, food and wood which account for 55–70% (by weight) of

a community's residential solid waste. The two basic processes applied in large-scale composting are classified as windrow-based and in-vessel technologies. In windrow systems, waste is conveyed to a central open air facility and formed into windrows that are 3–5 feet (1–1.5 m) high. The windrows are turned periodically to maintain a stable temperature and decomposition rate and water is periodically added to maintain an appropriate level of moisture content. After the targeted decomposition level has been attained, the composted product is ready for assembly and distribution to end- users. Vessel systems employ considerably more sophisticated technologies which offer a highly controlled enclosed environment for affecting the biological decomposition, thus leading to a high quality product. This system though is more capital intensive than windrow technologies and the sophisticated techniques require highly trained facility operating personnel. Therefore, the composting process is anticipated to play an important ecological role in the promotion of the biological carbon cycle. Similarly to the recycling of other materials, composting requires high quality raw materials, thereby ensuring that no toxic and hazardous residues are included in the product. In addition to compromising product quality, materials that are resistant to biodegradation may severely affect compost processing. Non-degradable plastic films may interfere with the film screening of the composted product by plugging the screen or reduce the degradation of biodegradable materials by blocking the oxygen flow. The composting process is further affected by temperature, moisture, pH, nutrient supply and oxygen availability while temperature also plays an important role in hygiene (Hamelers, 1994; Hanna, 1994; Vos, 1994; Beffa *et al.*, 1995; Siegenthaler, 1995; Peringer *et al.*, 1995; Guneklee and Kubocz, 1995; Neumann, 1995; Gajdos, 1995; Schaub and Leonard, 1996). The composting process is shown in Figure 15.14.

Recycling

According to Waite (1995), 'recycling is a very broad term referring to the conversion of waste into a useful material'. While recycling is second in priority waste management options, it has gained ground in many European and American countries as an essential ingredient for the reduction of wastes that must be landfilled. Over the last decade, the emphasis on the part of municipal solid waste management has been on recycling due to the introduction of waste management hierarchy. Recycling is a relatively old method with a well-recorded history. Metals have been recycled since their discovery because of their high value, rarity and properties that allow near indefinite reprocessing. The recycling of old textiles is equally old since they were used for the production of paper. Among the several factors which contributed to improving the recycling process are the decrease in available landfills and the urgent need for raw materials recovery that could be used by reducing the amount of natural resources consumed. Moreover, the increasing public interest in environmental protection enhanced the importance of recycling as an alternative solution to the constantly increasing waste problem (Vogas, 1995; Alter, 1997).

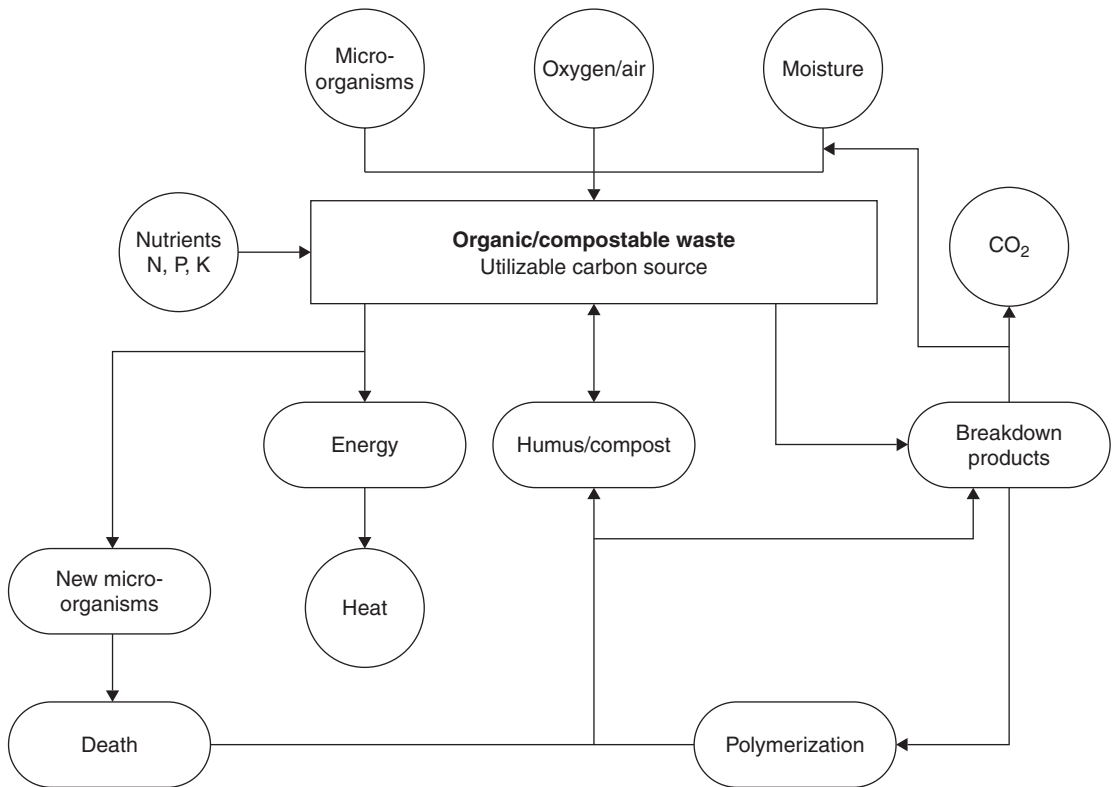

Figure 15.14 Composting process (adapted from Arvanitoyannis, 1999)

According to NSWA (National Solid Waste Management Association), recycling consists of five basic steps:

- 1 Collection and sorting of recyclable materials from the waste stream
- 2 Raw material reclamation by special treatment, so that they could replace virgin materials in manufacturing operations
- 3 Marketing of the recycling materials
- 4 Market establishment for recycled materials
- 5 Public involvement in the recycling programs operations
- 6 Collection recycling programs target the useless materials from the waste stream and treat them in such a way so that they could return to the industries as raw materials for packaging applications (Vogas, 1995).

Any responsible recycling operation has to meet market, economic and environmental requirements. The viability of recycling depends on the following factors:

- 1 the packaging or product design: since the product should be designed for recycling, mixed plastic materials complicating the recycling operations should be avoided

- 2 the raw materials: it is essential that the product does not contain any non-recyclable raw materials
- 3 management operations: i.e. identifying distribution channels
- 4 legislation: inspection of legislation for packaging and taxes involved to verify that it does not interfere with recycling management options
- 5 consumer education concerning recycling: increasing the percentage of informed and educated consumers concerning recycling further promotes the recycling management scheme
- 6 the technological advances and their applications: this plays an important role in improving the recycling processes (Vogas, 1995).

As far as the economic viability of recycling is concerned, it needs to be measured against the alternative waste management operations. The cost of recycling is mainly governed by three elements (Pearson, 1996):

- 1 the cost to collect and to sort
- 2 minus the cost of landfill avoided
- 3 minus the revenue from the recyclable sold by the material recovery facility.

Industrial recycling is so well established that under ordinary commercial practices many secondary materials are destined only for recovery or reclamation and not for discard and final disposal (Alter, 1997). The percentage of recycling of glass, aluminum and PET in the European Union and the USA is given in Figure 15.15.

Plastic recycling

The number of recyclable materials collected through the waste stream is quite large and consists of glass, plastic, scrap metal, tins, paper and boards, fabrics, oils, construction materials, ash and organic substances (Waite, 1995). Plastic makes up

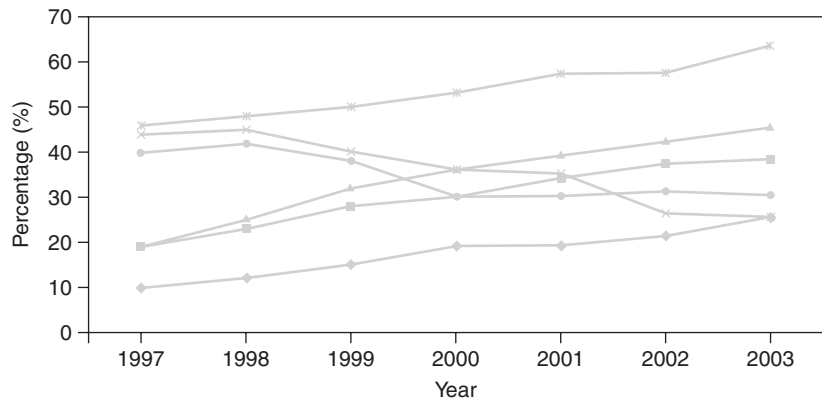

Figure 15.15 The percentage recycling of glass, aluminum and PET in the European Union and the United States (◆ PET in EU, ▲ aluminum in EU, * glass in EU, ■ PET in the USA, X aluminum in the USA and ● glass in the USA) (adapted from <http://container-recycling.org/aluminrate/gaphs.thm>, <http://europa.eu.int/lib/>)

around 8% of the total waste weight out of which nearly 85% are thermoplastics: mainly PET (polyethylene terephthalate), HDPE/LDPE (high-density/low-density polyethylene), PVC (polyvinyl chloride) and PP (polypropylene). The recycling rate for all plastic bottles dropped from 24.5% in 1996 to 23.7% in 1997. PET soda bottles represent 26% of total plastic bottle production and 40% of total plastic bottles recycled. PET beverage and soda bottles combined represent 44% of total plastic bottle production and 48% of total plastic bottles recycled. The recycling rates for PET soda bottles and for all PET bottles have been in decline for several years in the USA. PET soda bottle recycling rate (36%) was 8% lower than in 1996 and 25% lower than in 1994. Total PET bottle recycling rate (25%) was 9% lower than in 1996 and 18% lower than in 1994. One reason for the drop in the PET bottle recycling rate is the fact that PET resin production increased 45% between 1994 and 1997. Another is the fact that 60% of the PET soda bottle market is made up of single-serve bottles and most of those soda bottles are consumed away from home and away from curbside recycling bins. If the major soft drink companies were to use 25% recycled content in their PET soda bottles, they could boost the PET bottle recycling rate from the current rate of 36% to 61%, the total PET bottle recycling rate from 25% to 40% and the total plastic bottle recycling rate from 24% to 30% (Anon, 1994, 1998).

Statistics show that plastic waste tends to become one of the largest categories in MSW. Although only representing around 4% of total oil consumption, plastics represent a valuable resource. The 4% of the world's oil consumption used in plastic products actually helps users of oil (transport, heating, etc.) to become more energy efficient. Therefore, plastic recycling is important to the plastic industry, energy savings and the environment.

In the USA, plastics account for 13% by weight of waste and are handled by MSW management operations. The USA has historically relied on landfilling as its principal disposal technique. In 1972, approximately 20 000 landfills were operational, while in 1990 these were reduced to 6300 landfills in which over 80% of US MSW was disposed. The number of landfills is expected to decrease even further to 2100 by the end of 2000, while recycling and other waste management techniques would handle the main quantity of wastes (Anon, 1990; Jenkins, 1991; Liesemer, 1992). In contrast to the USA, Japan, with a much higher population density, in 1990 employed landfills for only 52% of its solid waste and Western Europe about 60%. Incineration, combined with energy recovery, was widely used in Japan (47% of MSW) as an important method of solid waste disposal in 1990 (Jenkins, 1991). Currently, in Western Europe, about 75% of plastics are landfilled, while 25% are recovered in the form of either new material or useful energy. In 1993, just over 50% of MSW generated in Sweden was incinerated and the energy recovered was used for district heating (94%) and for electricity (6%) (Tamaddon *et al.*, 1995). Finally, only 8% of MSW in Canada is incinerated, one of the lowest proportions among developed countries. Canada is the leading country in the amount of waste per capita sent to landfill and has below average rates of diversion to recycling or composting (Gilbert, 1998). Even though recycling is becoming increasingly important, not many comparative figures are available and there are large differences in performance in recycling rates between countries (APME, 1999). The European Community generally recycled by mechanical recycling about 7% of the total plastics consumed in 1995.

In Western Europe, there was a recovery of 25% of the plastics consumed during the period 1996–1997 (4 364 000 tons) while, at the same time, there was an 8% increase in total plastics consumption and a 12% increase of recycling volume in 1996. Eight percent of plastics recovered from Europe's waste stream was mechanically recycled with agriculture (31%) and distribution sectors (23%) remaining the two sectors with the largest proportions of mechanically recycled plastics. Feedstock recycling rose by 33% from 251 000 tons in 1996 to 334 000 tons in 1997, but this method is used only in Germany. Europe, in 1997, recycled 14–15% of plastic packaging waste, of which 25 million tons was turned into energy (<http://www.apme.org/press/htm/PR030299.htm>). In 1995, Germany recycled 60% of consumed plastic of which 20.56% was recycled mechanically, 27.85% was sent abroad and 9.56% by feedstock recycling. In 1996, the total recycling rate rose by 7.6%. After 1991, when the packaging ordinance was set in Germany, there was an enormous increase in its national recycling rates. In 1991, Germany began a very ambitious plastics recycling plan, the aim of which was to separate and recycle 80% of plastic components in packaging waste (Plinke and Kaempf, 1995). In 1994, it was estimated that 460 000 tons were collected, although there was a recycling capacity of 250 000 tons. Unfortunately, this surplus was dumped in other countries, undermining their own recycling industries (Ball and Unsworth, 1995). Italy is the second country in Europe in terms of recycling plastic industries. In 1992, the number of recycling industries that imported recyclable materials from the international market reached a rate of 66.5%, while there was a reduction in the imported quantities (Pinetti, 1995). In 1995, Austria and Switzerland mechanically recycled 15% and 11.9% of plastic waste, respectively (Mader, 1992; Hertzog, 1995). In Switzerland, 80% of household waste was incinerated and 20% landfilled in 1990, while 49% of the remaining urban solid waste was successfully recycled in 1993, which accounts for a total of 1 370 000 tons of waste. Out of this waste, 6100 tons of PET (72% of beverage containers) were recycled (Fahrni, 1995). Moreover, according to the latest figures from PET Container Recycling Europe, PET recycling had risen by 66% in 1996 throughout Europe. In Switzerland, plastics were collected early on and also used as regranulate, but the recycling rate in Switzerland and neighboring countries is disappointingly low at about 5–6%. It is estimated that more than 700 000 tons were consumed in Switzerland, of which only 400 000 tons were collected and returned for recycling and only 35 000 tons of regranulate were used for further manufacture (<http://www.polyrecycling.ch/english/kvs.htm>). The USA recycled about 2% in 1985, less than 5% of total plastic waste in 1994, while there was an increase of about 4% in recycling plastic in 1996 (Jenkins, 1991; Liesemer, 1992). The official recycling rate for the year 1997 increased to 27% of total municipal discards, twice the rate of a decade ago, while 9.5% is mechanically recycled. Nearly 1.4 billion pounds of post-consumer plastic bottles were recycled in 1997, a 4% increase from 1.32 billion in 1996. Even though more plastic bottles were recycled in 1997 than ever before, the recycling rate for plastic bottles decreased from 24.5% in 1996 to 23.7% in 1997. Recycling of PET soft drink and beverage bottles reached an all-time high of 649 million pounds for 1997. The recycling rate for PET bottles was the highest overall bottle recycling rate of any resin type at 25.4%. HDPE bottle recycling increased 7% in 1997 to 704 million pounds. Both natural and pigmented bottle rates saw significant gains in 1997. In US the percentages of recycled plastics for 2004 were 22, 26

and 3.2 for PET, HDPE and PP, respectively. As regards US post-consumer bottles recycled, in 2005, was 24.3% (www.plasticsresource.com).

In Australia, recycling comprised about 11% of the semi-rigid and rigid plastics disposal operations in 1992 and recycled about 42% of HDPE, 29% of PET, and 6% of vinyl polymers in 1996. As far as Japan is concerned, in 1995, 28% of total plastic waste was recycled: 11% mechanically and 17% by thermal recycling, 35% of plastic went for incineration and 37% was dumped on reclaimed land without any prior recycling. Furthermore, it was expected that by the beginning of 2000, more than 90% of plastics would be recycled in Japan (20% mechanically and 70% by thermal recycling), while landfilling would account for less than 10% in waste management operations. Hong Kong recycles much of its industrial and commercial paper and plastics with this taking place entirely on the basis of existing market prices. However, in the case of domestic solid wastes, the level of recycling is generally low. Although aluminum cans are nearly 100% recovered, only small amounts of consumed plastics and paper are recycled (Okawa, 1995; Barron and Ng, 1996). In the EEC, it is expected that 50–65% of packaging materials would be recovered and 25–45% would be recycled by a minimum for each material of 15% by weight. In developing countries such as India, the problem of waste becomes a major issue since the collection, transportation and disposal are unscientific and chaotic. Since formal investment on infrastructure is not increasing, most of these countries have to rely on private sector initiatives for waste disposal (Dasgupta and Sharma, 1995; Gupta *et al.*, 1998).

Collection of recyclable materials In most countries, the collection of MSW falls under the jurisdiction and direction of local authorities. Such authorities could be district councils, municipalities, or county councils. Each waste collection authority is responsible for organizing the collection of MSW for its area and delivering the waste to a point of disposal as directed by each country's ministry or responsible nationwide authority. This is an enormous task for the authorities because communities have to learn how to transform the collection to an economically viable enterprise. Traditionally, trash has been collected at the curbside of the homeowner. In such cases, it is possible to obtain 70% or more of the recyclables from the household wastes. In contrast, voluntary drop-off and payback approaches to gathering the recyclables from household wastes amounts to only 20% and 10%, respectively. In several cases, a mixed system of collection has been endorsed (Chiellini, 1994; Chang *et al.*, 1995). As far as hazardous household waste is concerned, several countries have already introduced national legislation for centralized collection schemes. It has been estimated that plastics constitute about 40% of the total volume of hospital waste. Many pilot plants have been set in various hospitals because it was proven that packaging waste is more easily collected and recycled in hospitals than private households provided the required infrastructure and management are in place. Research and commercial experience clearly show that the more complicated the job becomes for the householder, the less recyclable materials are likely to be obtained. Since the capital cost for equipment to collect material at the curb and the labor associated with getting the material into the truck represent about 70% of total collection costs, which equals to 50% of total handling cost, it is essential for the authorities to design a highly efficient collection system (OECD, 1987; Gordon,

1991; Young and Gordon, 1991; Gellenbeck, 1995; Beattie and Kerell, 1995; Wather-Mauschat, 1995; Lamber *et al.*, 1995).

Drop-off centers This is the simplest method for collection of recyclable materials. The system operates by placing specially designed buckets of large capacity at strategic spots in the municipality. The public is asked to collect the recyclable materials and transfer them by their own means to the drop-off centers. Then the local authorities are responsible for delivering the materials to the waste operation facilities. Basic advantages are the low capital cost necessary and the possibility for a 24-hour operation. Usually, the lack of public cooperation in that collection scheme is the main disadvantage of this method. It is quite inconvenient for the public to collect and dispose the materials at the drop-off centers, while there is also the contamination problem of the recyclable materials. It is difficult for the collection scheme to result, by itself, in high recycling rates. Many local authorities that operated such drop-off centers have concluded that:

- 1 Sites must be selected to provide maximum access but minimum nuisance to neighbors
- 2 All centers should be frequently emptied to ensure that there is always capacity to deposit delivered materials
- 3 It is essential to maintain sites and to manage the littering problem thus avoiding any health implications (NSWA, 1990).

Payback centers These are centers where the consumer deposits the recyclable materials and receives a compensation to ensure that cooperation will be maintained. The basic advantage is the high quality of obtained material and high public involvement rates. Long distances between consumers and these centers make the operation of this method rather difficult (Vogas, 1995; Pearson, 1996).

Combination of systems There are numerous examples of how an appropriate combination of the abovementioned methods resulted in viable and successful results (Brandrup, 1992). The method that each local authority will use depends on waste collection operations, experience obtained by other municipalities, possibilities provided by the particular site, population characteristics, convenience to the consumer, recycling goals, number of individual materials, contamination issues, capital and operational costs, raw materials market, public behavior, current working positions, available technology, legislation, weather conditions, hygiene issues and political factors. It is important to realize that recycling is not only a collection and recovery method of waste, but the last part of the life cycle of the materials in which the consumer/recycler is a key factor (Vogas, 1995).

Sorting

After collection, the recyclables are conveyed to a facility for processing into a form suitable for sale as raw materials. Plastic and glass can first be separated from each other by mechanical or manual means and then once more according to their type. Sorting is carried out in specially designed sorting plants which employ semi- or fully automatic processes, depending on the type, size and technical standards of the plant. The introduction and use of automated plastic sorting systems have lowered processing

cost and improved the purity of the separated plastics over the past few years, thereby increasing the quantity utilization of recycled plastics.

Various separation systems are used in different countries with varying capacity and sensor types implemented, such as the OTTO system (Germany), PET recycling Schweiz (Switzerland), P & R environmental (USA) and Ipia (Novate Milanese). The technologies for separating post-consumer plastics into their appropriate components fall into two categories: macro-separation and micro-separation.

Macro-separation involves removing discarded materials from waste and separating them into different components by handling manually or automatically the individual items. Macro-separation allows separation of a wide range of materials from each other. The following techniques and methods fall under these categories:

- 1 Gravity/centrifugation
2. Methods based on the shape of the individual fragments (manual, 3D measuring devices)
- 3 Optical (X-ray, IR, NIR, fluorescence, etc.)
- 4 Metal detectors
- 5 Sonic techniques (ultrasonic technique).

Micro-separation involves separating polymers by type after they have been shredded and chopped down to small pieces of approximately 1/8 to 1/4 inch (0.3–0.6 cm) in diameter. This category comprises techniques based on:

- 1 geometry (air classification, micronization)
- 2 density (hydrocyclon, swim/sink)
- 3 melting point (heated rolls)
- 4 electrostatic
- 5 mechanical (peeling)
- 6 solving behavior (temperature gradient).

Gravity and centrifugal techniques make use of different density (specific gravity) of the materials. Such a system is employed by Duales System, where the mixed plastics, after being cleaned, are suspended in water and enter the centrifuge as a suspension. Particles with a higher density of water precipitate down to the centrifuge bowl while the lighter particles float on the surface and are extracted. Sorting out specific types of plastic is feasible but the process has to be repeated with several centrifuges. Other methods employ rotating disks and inclined belts. The principles of plastic flotation show that it is more flexible than other techniques and could prove useful in separating mixtures of plastics, but more research needs to be carried out for its successful implementation in the industry. Separation according to shape can be conducted manually. As far as the optical methods are concerned, these are based on IR, UV and visible spectroscopy, laser-induced plasma spectroscopy, X-ray spectroscopy, fluorescence and near infrared (NIR) detectors. Infrared spectroscopy uses the way different materials respond to infrared light for identification. Although infrared spectroscopy is very selective and rapid, it is rather expensive and unsuitable for industrial applications, apart from specially

sorting installations, because only thin-film specimens can be scanned. X-ray spectroscopic processes that are commonly used are fast, reliable techniques, but are appropriate only for PVC detection since they depend heavily on the layer thickness while sources of radiation are objective, comparatively expensive and of limited applicability. This process is usually combined with infrared spectroscopy. Some of the latest methods employ NIR systems which are proven to be more advanced compared to the IR because of its fast response and higher detectability. In this area, a tremendous amount of research has been carried out over the past few years. A system using NIR was developed by Buhler and launched by late 1993. The system, named NIRIKS, enormously increased the measuring speed and was designed as a pure industrial unit.

The system was flexible, rapid and quite accurate. Another system using NIR was developed by Bayer and employs fluorescence spectroscopy (XFS) for identifying halogens and heavy metals. Short wave near infrared spectroscopy uses low wavelength infrared light for polymer identification. The technology is quite limited but the equipment is easy to use, compact and portable. Fourier Transform Mid Infrared Spectroscopy (MIR) uses the light reflected from a plastic for identification. The main systems available need a relatively smooth surfaced plastic to be effective. MIR systems are accurate, but the polymer to be identified needs to be close to the sensor for at least a second and identification takes a few seconds more. Systems which use UV and visible spectroscopy are also used for polymer identification. Electrical charges vaporize the plastic's surface and the analysis of the emissions gives an accurate identification regardless of the color or coating. Computer software is essential in a device that employs this technique. Another technique is based on laser induced plasma spectroscopy where lasers are used to vaporize the plastic's surface and the emissions are analyzed by a spectrometer. The device is highly accurate, additives can also be identified and the method is quite rapid. Raman spectroscopy is a method under development that is expected to become one of the most reliable identification technologies. This system uses lasers to generate light from the sample which provides identification upon analysis. Laser impulse thermography is another identification technique that uses laser beams. A carbon dioxide laser generates two 'spots' of energy onto a sample. The rise in temperature is measured, as is the cooling rate which both differ based on materials. Although fast, it is still under development because of current limitations. Mass spectroscopy may also be used in identification. Finally, color images can be identified with special digital cameras to recognize different colors for sorting mixed plastics or removing contaminants. In addition, another system uses people to identify and sort items passing on a conveyor belt simply by their touching the image of selected items on a video screen. Electrostatic techniques are based on the electrical properties of plastics.

Plastics have a range of electrical properties and any differences can be used both to identify and separate them. The existing devices based on electrostatic properties are portable and cheaper than many other systems. Unfortunately, they are only really effective at differentiating plastics with distinctly different characteristics, which is a limitation factor regarding their applicability. Any water in the system can also cause problems. A project funded in Germany called 'optical recycling' aimed at developing a reasonably priced process in which a single compact device would detect the type of plastic by using NIR, the color with color cameras, the shape by using a 3D measuring device and any impurities and residues present in the package with an X-ray module.

Strongly charged particles of plastics are deflected in free fall in a high-voltage field (120 000 V) towards the electrode and are separated. This method of sorting is based on electrostatic differences between polymers and it is independent of density, size or shape. The advantages of this technique are its effectiveness and the low energy required, but it is still on the pilot scale and the presence of additives makes the separation difficult.

Another technique is the use of tracers (i.e. fluorescent) for identification and sorting of plastics. A European project, set for the implementation of tracers on an industrial scale, concluded that it is a fast and reliable identification technique. Furthermore, marking by tracers can differentiate between grades of generic type plastics and also by destination, e.g. one specific tracer used for plastics not to be recycled. The ultrasonic technique is based on the use of ultrasound attenuation measurements which were developed for medical diagnostic analyses by Langton. A specialized computer was designed for this specific application and patented by Hull and Langton in order to assist the classification and identification of polymer waste. The ultrasonic analysis offers a cheap reliable technique able to be used both on and off line.

By air classification, it is quite easy to distinguish a thick walled from a thin walled polymer such as LDPE and HDPE. Any small and big fragments can be effectively identified by micronization. This method is usually applied to separate PET and PVC. The different specific densities of plastic are used in some sorting plants for developing automatic sorting techniques as long as the mixed plastics to be sorted are not too heavily contaminated. The hydrocyclone is an old technique based on this property. In a hydrocyclone, the shredded and washed plastic fragments are separated in a centrifugal field according to their density resulting in purity of more than 99%. Another device recently demonstrated is based on solubility of polymers. It is thus possible to separate six or more polymer categories by dissolving them all in a solvent system and taking advantage of the different temperature dissolving point (each polymer dissolves at a different temperature). This method proved to be effective both in laboratory analysis and industrial applications. This is a very promising technique since modern packages usually employ several polymers in order to achieve the desired properties. Finally, molded-in codes can be used for identification and sorting of plastic waste. Molding in bar codes appears to be the simplest, most cost-effective approach, but the main disadvantage resides in the possibility that any damage occurring to the label, which is likely to happen, would render the code illegible. The analysis on the composition and properties of plastic waste and the physical properties of plastics demonstrate that, although several separation technologies can be applied to separate mixed plastics, their applicability is still very limited (Soler, 1992; Brown, 1993; Hull *et al.*, 1994; Eisenreich *et al.*, 1995; Schudel and Koller, 1995; Riess, 1995; Lambert, 1995; Kenny, 1995; Saetti and Peroni, 1995).

The techniques used for separation of different kinds of plastics are based on differences in density, shape, color, physicochemical properties and solubility. The solubility-based processes (SDP) include stages of dissolving a series of incompatible polymers in a common solvent at various temperatures or in different solvents, so that one polymer is separated each time. These processes differ in the method employed to recover the polymer after the dissolution stage. So far, the SDP have been successfully applied in a laboratory scale for the recycling of PP pipes, rigid PVC bottles, PS waste

foam, LDPE film from greenhouses and HDPE bottles from agrochemical packaging (Poulakis and Paspaspyrides, 1995; Pappa *et al.*, 2001). The technique involves the following steps, shown graphically in Figure 15.16:

- 1 Cutting the waste into smaller pieces and, if necessary, washing with water
- 2 Preliminary separation of the initial mixture to two or more mixtures by flotation in water or another liquid
- 3 Addition of a solvent (S) that selectively dissolves only one of the polymers at certain conditions
- 4 Filtration to remove the non-dissolved polymers
- 5 Addition of an anti-solvent (AS) to precipitate the dissolved polymer
- 6 Filtration and drying of the precipitated polymer
- 7 Separation of the S/AS mixture by distillation for re-use
- 8 Application of the same procedure for each polymer of the mixture.

In this study, the SDP method was applied for the separation of mixtures consisting of polyolefins – low-density polyethylene (LDPE), high-density polyethylene (HDPE), polypropylene (PP) – in both laboratory and pilot scale. Excellent recoveries were achieved and the quality of the recycled polymers remained practically intact. The feasibility study of the method for a high capacity unit, based on the scale up of the pilot one, showed that the cost of the recycled polymer is comparable to the commercial price of the virgin one.

Dodbiba *et al.* (2002) studied the separation of polyethylene terephthalate (PET)-polyethylene (PE) and polyethylene terephthalate (PET)-polypropylene (PP) mixtures in order to improve the grade of the raw input used in PET bottle recycling. First, PET bottles and their caps (made of PE or PP) were shredded and the floatability of each polymer was tested. Even with the addition of the wetting reagents dodecylamine acetate (DAA) or polyvinyl alcohol (PVA), the results did not suggest that the required 99.995% purity of PET plastic could not be achieved by flotation. Second, the mixtures were separated with a sink–float process using a drum separator. Finally, as the required purity of PET could not be obtained by either technique alone, a system utilizing a combination of the two processes was developed. This system easily achieved the desired PET grade. Finally, some sink–float experiments were performed with a medium of magnesium sulfate (dense medium separation).

Shen and coworkers (2002) found that the floatability of all the plastics decreased with the addition of the surfactant, but they are different in floatability and follow the order POM < PVC < PMMA < PET < PC < ABS < PS. From the separation test results of several plastic mixtures, it was shown that the Gamma flotation method not only can be used to separate plastics mixture with different density, such as separation of POM and PVC from PC, POM and PVC from PS and ABS, PET and PMMA from PS and ABS, but also can be used to separate plastics mixture with similar density, such as separation of PMMA from PC. Products with grade higher than 99% and recovery higher than 97% can be obtained for the separation of some plastic mixtures. It was found that the depressing effect of surfactant 15-S-7 on the plastics is mainly due to

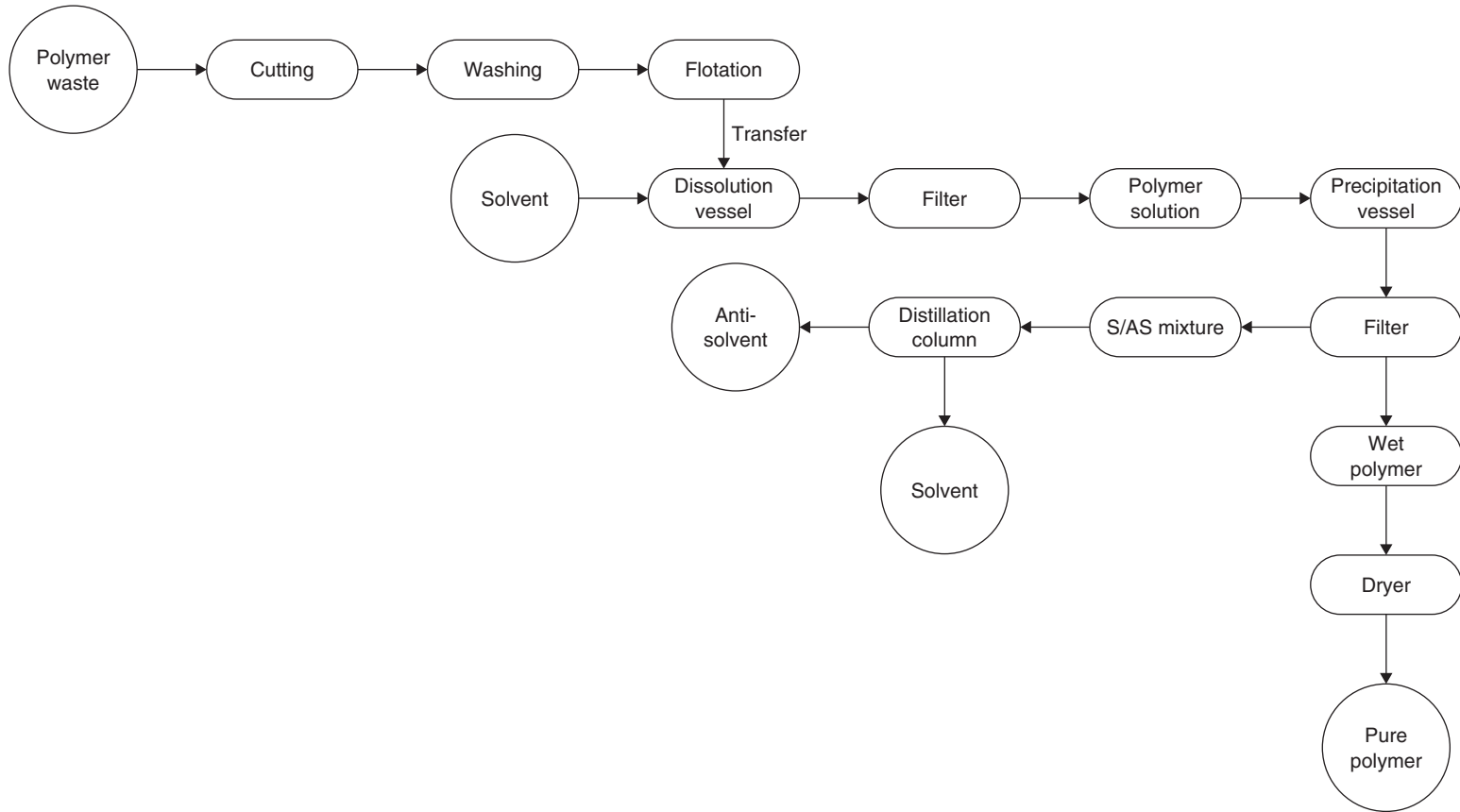

Figure 15.16 Flow diagram of the selective dissolution/precipitation method for the separation of polymer mixtures (adapted from Pappa *et al.*, 2001)

the reduced liquid surface tension and flotation selectivity for the plastics with identical particle size is dominated by contact angle, particle density and shape.

Over recent years, several experimental studies have been reported describing the separation of plastics by froth flotation. In principle, selective flotation separation of plastics can be achieved by:

- 1 Gamma flotation using a liquid medium with a specific value of the surface tension
- 2 chemical conditioning using adsorption of wetting agents
- 3 physical conditioning, e.g. plasma treatment or wet oxidation
- 4 hydrophobic modification using a chemical conditioning agent such as a plasticizer, for example, diisodecylphthalate on PVC.

In general, all these methods emphasize the modification of the plastic surface or the flotation medium and, in many cases, this can be successfully achieved on different plastics leading to high flotation selectivity with mixtures. From the results, it was shown that plastics flotation is dominated not only by surface chemical factors, but also significantly by gravity factors. It is suggested that plastics flotation is a combination of froth flotation and gravity separation. According to this relation, the idea of particle control was first applied for the separation of plastics mixtures. From the separation results, it was deduced that this method can greatly increase the separation efficiency for flotation separation of plastics mixtures. The particles in cutting products are not uniform in size and shape. Cutting products of PMMA and POM have a relatively wide size distribution and contain a considerable amount of particles of less than 1 mm which are difficult to depress by wetting agents. PVC and PS give an intermediate size distribution with an intermediate left tail but a small right tail. Finally, ABS, PC and PET gave a relatively narrow particle size distribution. Particle shape tends to be more irregular in the fine size fractions. The equation and the experimental results showed that particle size and shape control is important for plastics flotation. It is an effective way to improve the separation efficiency for plastics flotation (Shen *et al.*, 2001).

The dry separation of a mixture of three plastics by combining air tabling and triboelectric separation has been described (Dodbiba *et al.*, 2005). While air tabling is effective for particles of different density, the triboelectric separation can be used for separation of particles of similar density. Before commencing the separation tests, the effectiveness of the separating devices was evaluated by analyzing the effects of the particle size and the difference in density between components of the mixture. A two-stage process has been proposed for separation of mixed plastics prior to recycling. Polypropylene (PP), polyethylene terephthalate (PET) and polyvinyl chloride (PVC) were selected for investigation as they are widely used in the manufacture of everyday products. An air table was employed for the first stage of the process to collect a PP-rich low-density fraction and a PET/PVC high-density fraction. In the second stage, the PET/PVC fraction was separated by means of a triboelectric separator utilizing differences in surface charge. A mixture of PP, PET and PVC was selected for investigation. Each component amounted to one-third of the total mass of the mixture. Thus, high-density plastics (i.e. PET and PVC) amounted to approximately 67% of the total. Before commencing the separation tests, the effectiveness of the techniques

was evaluated by investigating the effects of the particle size and the difference in density between components of the mixture. The triboelectric separation was effective for separation of materials of similar density. However, an upper limit of the particle size was set after considering the magnitude of the surface potential attained by plastics and the maximum electric field strength that the triboelectric separator could create without causing electric breakdown. The air tabling was effective if the density difference between particles was at least 450 kg/m^3 and the feed was properly sized. A general schematic flowsheet of the dry process for separating mixtures of three plastics is shown in Figure 15.17.

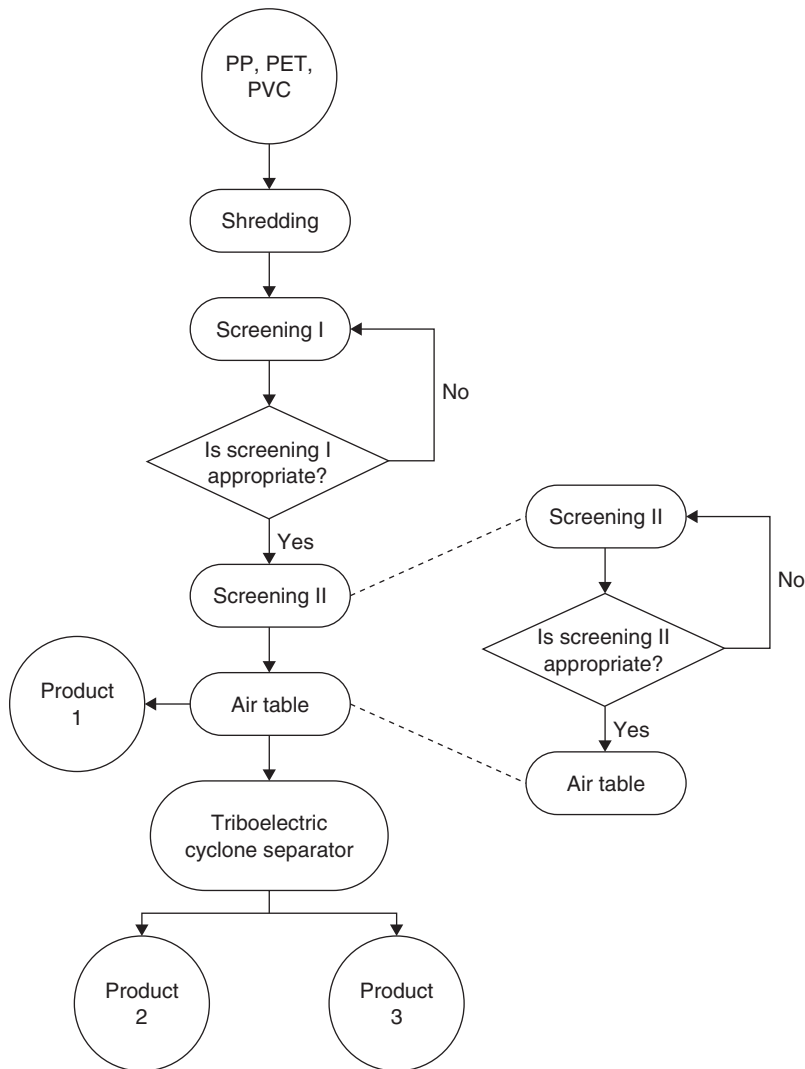

Figure 15.17 A general scheme flowsheet of the dry process for separating mixtures of three plastics (adapted from Dodbiba *et al.*, 2005)

The plastic waste samples (PET, HDPE and PP) were taken from an MSW separating and composting plant (Araraquara, SP, Brazil). The PET consisted predominantly of carbonated soft drink bottles, plus a few water and vegetable oil bottles. The HDPE and PP are mainly packaging materials from cleaning, personal hygiene, utensils, food and automotive mineral oil products. The polyolefins were mixed in a proportion 9:1 (HDPE:PP) according to a recent study on MSW composition (Mancini *et al.*, 2000). Owing to the heterogeneity of the contamination of these wastes, one lot (ca. 40 kg) for each of these materials (PET and polyolefins) was ground in a knife mill and then mixed and homogenized in an appropriate bag. Afterwards, three samples of about 3 kg each were taken from these lots and cleaned independently in order to achieve three typical samples of wastewater generated during the cleaning processes of these plastics (Santos *et al.*, 2005). Since polyolefins and PET have different characteristics, the conditions used during the washing process also differed from each other. Specifically for PET, a step that encloses the separation of labels and caps residue by differences in density is necessary. Furthermore, the susceptibility of PET during processing step to adhesive residues also requires more aggressive conditions in the washing step in order to maximize the adhesive removal (Sanko, 1999). Care was taken not to use high alkalinity content. As an alternative, increments on the bath temperature are recommended. Ordinary tap water without addition of any chemical was used for the pre-washing step. Caustic soda was then used in the washing step for both plastics, though surfactant was used only for PET. No significant differences in the effluent characteristics were found between the two types of plastic studied and between the pre-washing and washing steps, except those differences intrinsic to the cleaning processes (temperature, surfactant, caustic soda concentration). Some specific unit differences are necessary depending on the type of plastic used due to extrapolation of emission limits of oil and grease in the polyolefins pre-washing step and Pb excess in the PET washing step.

Cryo-comminution of plastic waste was recently introduced by Gente and coworkers (2004). Laboratory comminution tests were carried out under different conditions of temperature and sample pre-conditioning adopting CO₂ and liquid nitrogen as refrigerant agents. The temperature was monitored by thermocouples placed in the milling chamber. Moreover, different internal mill screens have been adopted. A proper procedure has been set up in order to obtain a selective comminution and a size reduction suitable for further separation treatment. Tests have been performed on plastics coming from medical plastic waste and from a plant for recycling spent lead batteries. Results coming from different mill devices have been compared taking into consideration different indexes for representative size distributions. The results of the performed tests showed cryo-comminution improved the effectiveness of size reduction of plastics, promotes liberation of constituents and increases specific surface size of comminuted particles in comparison to a comminution process carried out at room temperature.

Flame treatment was effectively used towards modifying the surface of plastics to allow water-based coatings to be attached. The effect of the treatment was to produce hydrophilic species on the surface of the plastic. The process is therefore potentially useful for the separation of plastics by froth flotation, provided that the production of the hydrophilic surface can be achieved selectively. Polyvinyl chloride (PVC) and

polyethylene terephthalate (PET) were selected for investigation as they were found as a co-mingled product from the recovery of beverage containers (Pascoe and O'Connell, 2003). A simple, but effective, flame treatment method for flaked plastics was developed. The treatment involved the use of an acceleration chute that delivers the flakes through the flame of an angled burner. In experiments with virgin plastics, the PVC was found to be less susceptible to surface modification than PET, as indicated by contact angle measurement. Separation of the treated virgin plastic by froth flotation was found to be possible, using careful control of frother addition. The technique was then considered for the treatment of post-consumer plastic bottles. It was demonstrated that flame treatment was effective in rendering the surface of both plastics hydrophilic, although the process alone was not sufficiently selective. Hydrophobic recovery of the PVC, but not the PET, was achieved by raising the temperature of the material to 140°C for a period of 10 min. A two-stage flotation process was tested for the separation of the plastics. In the first stage, PET was floated away from the PVC capitalizing on differences in particle thickness and surface contamination. The float product was then subjected to flame treatment and hydrophobic recovery prior to the second stage of flotation. In this stage, the PVC was conveyed to the float product leaving a PET-rich sinks fraction.

Hearn and Ballard (2005) developed two sorting techniques using the electrostatic properties of materials to produce separate material streams for the purposes of recycling. Trials were undertaken using typical common items of waste packaging giving encouraging results. Early results indicate reliable operation under a range of environmental conditions, however, the effects on sorting efficiency of extremes of surface contamination, moisture, temperature and humidity have yet to be quantified. It is recognized that the presence of high levels of surface contamination on the waste items to be streamed may cause problems, particularly for the triboelectric sensor probe. Preliminary examination of material from an MRF, however, suggests that these materials are generally not heavily contaminated with anything other than moisture. The presence of surface water does significantly influence both charge generation and triboelectrification. MRFs and plants where these techniques are likely to be applied lend themselves to the application of driers or air curtains which could be installed upstream of the electrostatic sorting area. It is also recognized that this technique may not be appropriate for all polymer types but can be used in conjunction with other techniques. Such techniques may include an optical sensor to separate PVC from HDPE and Fourier transform infrared spectroscopy (Hearn, 2003) to sort the stream containing PET/PETE and PS. Difficulties may be encountered with certain packaging geometries and the presence of labels and coatings. On all of these issues the use of the small triboelectric probe is an advantage as it can be directed at an area of packaging most likely to constitute exposed polymer.

Preparation for recycling

After the materials have been collected and sorted, they must be converted into a homogeneous purable bulk material which is easy to transport and store and is suitable for recycling. The quality criteria are: high bulk density, defined grain size, low chlorine content and low dust content. These properties can usually be achieved

within the frame of the agglomeration process. The agglomeration process is followed by the shredding and separating steps, thus reducing the mixed plastics to a grain size of less than 50 mm and producing a more or less homogeneous material. The target of agglomeration is to convert mixed plastics into a product with specific properties suitable for recycling. The final product should be pure and easily processable. In this process, the pre-shredded mixed plastics were fed into rotating blades and heated to 135–140°C. As a result, small pieces of film sheeting cake together and can then be processed into compact plastic granules. Moreover, inpelletizers are also employed so that plastics compacted by means of pressure are cut off by cutters and subsequently pelletized. However, agglomeration is considered a ‘young’ technology requiring further research and development work (Pearson, 1996).

Mechanical recycling

The purpose of mechanical recycling is to process post-consumer plastics and recover a secondary raw material for the production of new items (Pearson, 1996). Packaging material sorted into individual fractions is either melted down directly and molded into a new shape or melted after being shredded into flakes and processed into granules called regranulate. There are several mechanical recycling processes: extrusion and intrusion, injection molding, transfer molding process and regranulation (<http://ww/eps.co.uk/mechanical.html>). In the extrusion process, the regranulate is heated and melted into a plastic mass which is then transferred to molds for simple products such as profile section or sheets. The only difference between extrusion and intrusion processes is that, in the latter, impurities such as glass fragments, sand and wooden pieces can remain in the plastic melt. The extruder is designed in a way so that impurities are embedded in the plastic melt. The molten mass is pressed directly into molds such as honeycomb-type paving stones. Circulation of cold water speeds up the hardening process of the paving stones which can be removed from the molds after a short time. The molten plastic mass, during the injection molding process, is injected into a mold under high pressure. Similar to the intrusion process, the machines are designed for processing mixed plastics containing impurities. The molten plastic is pushed by the piston into the mold for the article to be produced. The pressure on the piston remains constant until the tray has cooled down and can safely be removed from the mold (Pearson, 1996). During the molding process, mixed plastics are shaped into finished products by means of direct melting and molding, either without or after only coarse pre-shredding. Finally, in the regranulation process, the post-consumer plastics are sorted into different fractions, heated and regranulated. The produced plastic is applicable in various sectors such as construction (frame sections, cable insulation, piping, insulating materials, etc.), packaging and logistics (film sheeting, hollow containers, transport containers, pallets) and industry (shaped parts for the car industry). Recycled films can be manufactured from used PE films. Films of recycled materials and virgin material can be permanently joined to produce frame sections of film sheeting by co-extrusion (<http://www.environment97.org/text/reception/r/techPapers/Papers/g19htm>). It is estimated that the recycling rate for foamed polystyrene can reach 100%. The material is broken down to its components and

either added to new foamed polystyrene packaging or regranulated to produce the starting material polystyrene which is utilized for the manufacture of injection molded parts. In Germany, a recycling rate of 40% has already been achieved. However, it should be mentioned that current standards and regulations prevent secondary plastics from being used to an even greater extent. For instance, packaging for foodstuff may only be manufactured from virgin polymers. Similarly, the production of certain types of piping prohibits the use of regranulate. In principle, most of the 9.1 M tons of plastic utilized in packaging in Western Europe could be recycled by remelting and extrusion or molding into films.

Actually in 1996, 53% of the plastic sales for packaging were recycled mechanically and more than 90% has been recycled in Germany since 1997. Therefore, the mechanical recycling process is an important technique despite the following problems that have been encountered in practice (Halle, 1994): the high cost of collection and separation equipment, the lack of a substantial and reliable market for the recycled material and limited applications (i.e. exemption of food packaging materials) for the recycled materials. The implications of mechanical recycling have partially influenced packaging design. The three predominant trends can be summarized as follows: the increased need for simple structures consisting of a single polymer or at least a single polymer type instead of complex multilayer structures, which are difficult to be separated into individual materials. Recent predictions for the packaging film market suggest the replacement of PS and PVC with PP.

Therefore, the use of compatibilizers – chemical additives that assist the blending of various polymer types – helps to alleviate some of the problems of blended polymers. The addition of 5% of a vinyl acetate EVA film grade polymer of 28% VA content substantially improved the properties of 85/15 LLDPE/PP mixtures (Teh *et al.*, 1994). Furthermore, several new linear ethylene polymers have been successfully used to increase the recyclable content of post-consumer recycled polyolefins to high levels, while maintaining good film properties (Begley and Hollifield, 1993). Safety and contamination considerations and current legislative standards are the main obstacles for an extensive use of mechanically recycled polymers by the food packaging industry. Nevertheless, pack designers and polymer scientists can facilitate the recyclability of food packs so they can be easily used for other applications. The obvious dominance of the food sector within the overall packaging market suggests that a response of this kind by the food packaging industry is expected to have a key influence on the future of plastic recycling.

The increasing consumption of polymeric blends results in a great environmental impact because the used plastics are discarded in nature in a non-rational form. Facing all these problems, recycling becomes a powerful strategy regarding the reduction of the environmental impact caused by plastic waste. Polymeric blends were prepared with mechanical recycling and characterized. LDPE/Al residues from cartoned packaging were blended with recycled HDPE/LDPE and virgin PE resins. It was observed that processability, mechanical properties, chemical resistance and water absorption are dependent on the blend compositions. Also, an aluminum film was found to remain as isolated particles in the polymeric matrix and the mechanical behavior of the blend depends on the aluminum dispersion. Either, the blend water absorption

depends on recycled material contamination, mainly polyamides. Finally, the amount of recycled material added to the blends determines both chemical stability and thermal characteristics (Paula *et al.*, 2005).

Recycling of mixed plastic wastes composed of low-density polyethylene (LDPE) matrix and polypropylene (PP) was carried out by compounding using single-screw or twin-screw extruders. Blends of virgin polymers were prepared to compare mechanical properties of both virgin and regenerated materials. First, a model composition of virgin LDPE/PP blend was prepared to study the effect of process parameters and that of different types of compatibilizers. Second, the results were applied to plastic wastes coming from industrial post-consumer plastic wastes. The mixture of plastic wastes was purified in a pilot plant with steps of grinding, washing and separating. The detailed treatment is shown in Figure 15.18. By adding compatibilizing agents such as ethylene-propylene-diene monomer, ethylene-propylene monomer, or PE-g-(2-methyl-1,3-butadiene) graft copolymer, elongation at break and impact strength were improved for all blends. The effect of these various copolymers was quite different and was in relation to their chemical structure. The recycled blends exhibited suitable properties leading to applications that require good mechanical properties (Bertin and Robin, 2002).

Feedstock recycling

The main purpose of feedstock recycling is to convert prepared post-consumer plastics into their basic components, such as oil, gas, naphtha, and to use them as secondary feedstocks in refineries or petrochemical industries for the production of new plastics, paints or adhesives. Post-consumer plastics may also be utilized as a substitute for valuable raw materials like oil. Plastics can be effectively applied in the production of steel. Currently, the carbon and hydrogen molecules bound in plastics are used for the reduction of iron oxide. A single industrial-scale plant for feedstock recycling has a capacity of 100 000 tons of post-consumer plastic per year. The techniques employed consist of hydrogenation, BASF process, etc. and are of crucial importance in the recycling of plastics (Caluori, 1995).

Steel and iron have been overtaken after a period of 3000 years as the most used and most versatile materials by the different kinds of plastics and this in a period of only 50 years. Feedstock recycling is one of the greatest challenges for the recycling of plastics and various technologies have been successfully demonstrated and continue to be developed. Kaminsky and coworkers (2004) investigated different processes such as degradation of plastics to monomers, pyrolysis into monomers and oil, gasification into syngas. Pyrolysis of mixed plastic wastes and elastomers is a cost-effective process to recover feedstocks for the petrochemical industry. The Hamburg process, using an indirectly heated fluidized bed, can be varied to produce mainly monomers, aliphatic hydrocarbons or aromatics. At temperatures of 450°C, poly(methyl methacrylate) (PMMA) is depolymerized to more than 98% of the monomer. However, the influence of fillers on the monomer yield has been studied. Polystyrene as feed gives up to 75% of styrene and 10% of oligomers. First demonstration plants are running for feedstock recycling of PMMA in a fluidized bed.

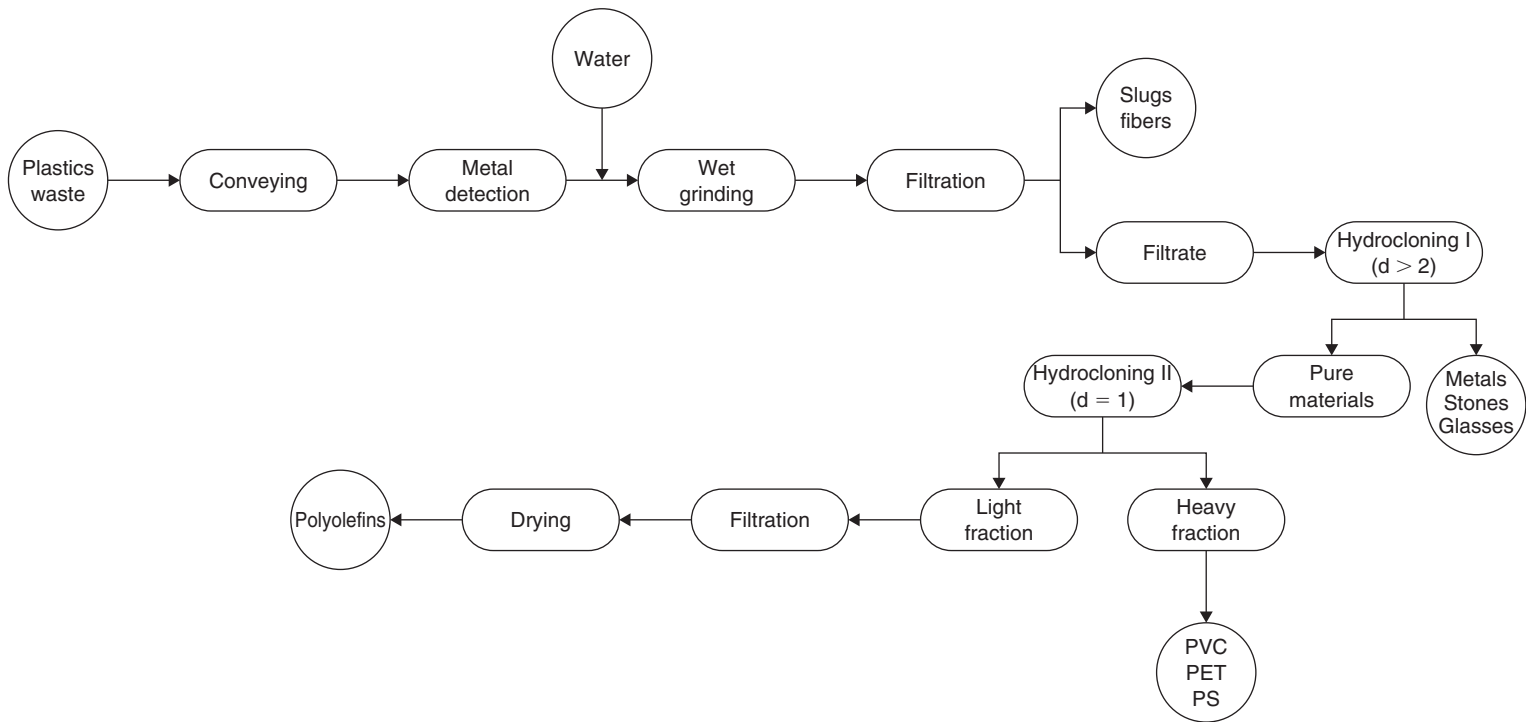

Figure 15.18 Flowsheet of the recycling pilot plant (adapted from Bertin and Robin, 2002)

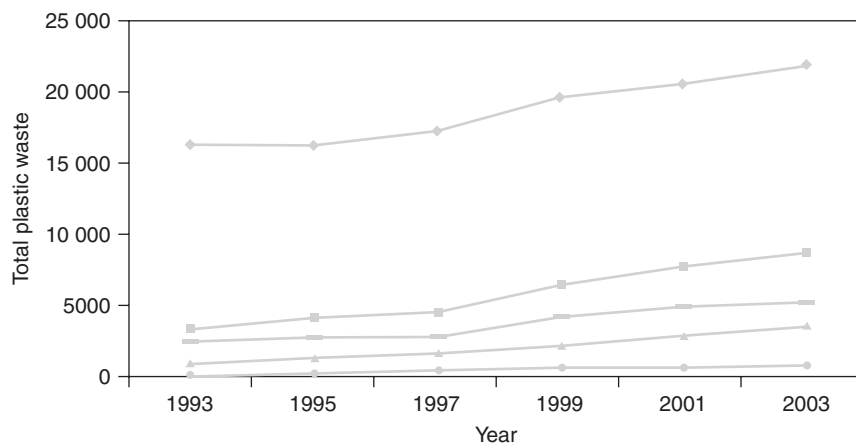

Figure 15.19 Total plastic waste generated and recovered in Western Europe (◆ total plastics waste, ■ total plastics waste recovered, — energy recovery, ▲ mechanical recycling and ● feedstock recycling) (adapted from Garforth *et al.*, 2004)

Schemes such as the Duales System Deutschland in Germany ('green dot') have addressed feed recycling, but there remains the high energy and process costs of the feedstock recycling technology. Thermal and catalytic cracking, although effective, require significant operating temperatures and are strongly endothermic, leading to large adiabatic temperature falls across reactors. Oxidation methods, energetically more favorable, are at high temperature and have associated difficulties such as dangerous emissions, product quality and expensive materials of construction. Hydrocracking studies have been limited to date and merit further study since the process is exothermic and can be carried out at significantly lower temperatures (Garforth *et al.*, 2004). Total plastic waste generated and recovered in Western Europe is given in Figure 15.19.

Feedstock recycling by catalytic cracking of a real plastic film waste from Almeria greenhouses (Spain) towards valuable hydrocarbon mixtures was studied over several acid catalysts (Serrano *et al.*, 2004). The plastic film waste was mostly made up of ambient degraded low-density polyethylene (LDPE) and ethylene-vinyl acetate (EVA) copolymer, the vinyl acetate content being around 4 wt%. Nanocrystalline HZSM-5 zeolite (crystal size ~60 nm) was the only catalyst capable of degrading completely the refuse at 420°C despite using a very small amount of catalyst (plastic/catalyst mass ratio of 50). However, mesoporous catalysts (Al-SBA-15 and Al-MCM-41), unlike as occurred with virgin LDPE, showed fairly close conversions to that of thermal cracking. Nanocrystalline HZSM-5 zeolite led to 60 wt% selectivity towards C₁-C₅ hydrocarbons, mostly valuable C₃-C₅ olefins, that would improve the profitability of a future industrial recycling process. The remarkable performance of nanocrystalline HZSM-5 zeolite was ascribed to its high content of strong external acid sites due to its nanometer dimension, which are very active for the cracking of bulky macromolecules. Hence, nanocrystalline

HZSM-5 can be regarded as a promising catalyst for a feasible feedstock recycling process by catalytic cracking.

Hydrogenation in the Kohleol-Anlage Bottrop The hydrogenation process in the Kohleol-Anlage Bottrop serves to recover synthetic crude oil and gases that can be used for industrial purposes. At the beginning of the 20th century in Germany, work was initiated on the development of feedstock recycling techniques and technologies in order to enhance the recovery of energy and raw materials. Initially, the purpose of hydrogenation was to recover oil from coal. At the beginning of the 1950s, the utilization of this form of hydrogenation ceased because of its high cost. Only after the second oil crisis was interest in development work on hydrogenation techniques rekindled (Kohleol-Anlage, Bottrop). In the second half of the 1980s, industrial residue was processed to an increasing extent in Bottrop because of the detoxifying effect that hydrogenation has on various types of contaminated residue, such as oil containing chlorine. Since hydrogenation occurs at very high pressure, the plastics have to be liquefied first to make them suitable for pumping. The solid liquefaction of hydrocarbons is called depolymerization and is applicable to the long polymeric chains resulting in fragmented short and mobile units. Cracking may occur when the plastics are heated for a longer period of time. After liquefaction, high-pressure pumps compress the mixture at a pressure of 15–250 bar. Finally, the liquid mass is heated to 440–480°C and is transferred to a high-pressure column reactor where the actual hydrogenation takes place. The carbon chains are cracked to an even greater extent and hydrogen is bound at the fragments. Hydrogenation occurs in three series of connected column reactors and then the product is exposed to a lower pressure so that solid, non-usable components are removed. The final products consist of synthetic crude oil and gases (mixture of methane, ethane, propane, butane, pentane and hexane). Utilization of a closed system is advantageous because there are no harmful emissions to the environment (Ball and Unsworth, 1995; Pearson, 1996).

Production of gas Several gasification techniques are used worldwide by companies such as Thermoselect, TEES, Texaco, BCU, etc. The plastics fed into the process for the production of gas are converted into a gas mixture (mainly carbon monoxide and hydrogen) at 800°C or higher by adding oxygen and steam. Similar to hydrogenation, any chlorine containing compounds present in the plastic waste (such as PVC) are decomposed by the high temperatures used in the process and are converted to a more useful product. Heavy metals and mineral substances are melted into a vitreous slag to be used in road construction work at later stages of the procedure. This process of binding heavy metals and minerals is known as vitrification. The obtained crude gas is cooled very abruptly in order to prevent the formation of harmful substances such as dioxins and furanes. Tars and solids are first separated in a further step of the process and then the liquid tars, consisting of carbon and hydrogen, can be converted into gas by employing a special gasifier for liquid products. The production of methanol from waste materials still remains of major importance worldwide (Pearson, 1996).

Coal can be replaced by a thermal equivalent of this gas in the rotary kiln or can be effectively used in gas engines. The mineral raw materials can probably be used for the production of a special cement. Several research groups have taken an interest due to the importance of this recycling method and the necessity for further research. Therefore, in BCU (Bundrer Cementwerke AG, Switzerland), various gasification processes are currently being studied, tested and compared. Among others, for example, the fluidized-bed method was studied, by using air as a gasifying medium, for the thermoselect process which gasifies with pure oxygen. This latter method, according to BCU, has numerous advantages, such as higher gasification temperature, much smaller volume of gas of very high quality and clean and slag which can be drawn off as fluid. Its only disadvantage resides in its high initial investment.

During the thermoselect process, the material is compressed to about one-tenth of its original volume without any prior treatment. The material is pressed into compact plugs which are fed into an air-tight heated degassing duct. The organic components are driven off and converted into carbon by increasing the heat in the duct. The carbon forms a continuous renewed active carbon filter which absorbs any pollutant. After being mixed with inorganic components, such as metals and minerals, it is fed into a reactor where gasification occurs in the presence of oxygen at temperatures above 2000°C. At these temperatures, the metallic, mineral components and chlorinated hydrocarbons are completely decomposed. The reformation of dioxins and furanes is prevented by rapid cooling of the hot gas. This gas, which represents about 10% of the amount of gas for a refuse incineration plant, undergoes thorough cleaning and can be utilized as an energy carrier. The liquefied slag components are fed into a second high-temperature reactor where the mineral components, with the addition of oxygen, gas and propane at the temperature of 1800°C, are converted into raw materials. Metals are separated and made available to the metal industry (Caluori, 1995). In most gasification systems, environmental emission controls are significantly reduced since the volume of gas emitted is much smaller than in traditional incineration systems. Furthermore, these systems have low emissions of dioxins, acid gases and other pollutants because of the relatively high quality of the fuels combusted.

Another research study conducted by De Stefanis *et al.* (1995) under the supervision of ENEA (Italian National Agency for New Technology, Energy and the Environment) focused on the observation of plant operations, data collection and extensive sampling of the produced gas. Several more studies have been conducted in this area over the last 10 years (Rijkema, 1995; Seddon-Brown, 1995; Redepenning, 1995; Carlsson, 1995; Brunner and Fey, 1995; Steiner, 1995; Edlinger, 1995; Trauberg, 1995; Calamius, 1998).

BASF process BASF was quick to realize that mechanical recycling can only be but a partial solution. The task of the BASF pilot plant was to convert used plastics into petrochemical products which can be used in the BASF plant network as raw materials. The agglomerates are delivered in silo trucks to BASF and pneumatically conveyed with nitrogen to the storage silos of the pilot plant. The agglomerates are then converted into petrochemicals by means of a three-stage process (Wanjek, 1995). Similar to hydrogenation, the BASF process also starts with liquefaction of the

plastics at about 30°C in the absence of air and simultaneously a dehydrochlorination of the PVC present in the plastic mixture occurs. The released hydrochloric acid is absorbed and reprocessed in the hydrochloric acid unit of the plant. In the second step, the liquefied plastics are cracked into petrochemical feedstocks without the addition of hydrogen. At temperatures above 400°C, the polymer chains are fragmented down to shorter length chains and various oils and gases are formed. The gases are compressed and used as feedstock in a steamcracker. In the third step, the mixture is fractionated producing a sulfur-free product similar to crude oil (naphtha), short hydrocarbon molecules and aromatic compounds. All these products can be used by the network of chemical plants available at BASF in Ludwingshafen. For instance, gaseous molecules such as ethylene and propylene are recovered from naphtha in the steamcracker. After separation (distillation), these can be directly used for polymer production (polyethylene, polypropylene, etc.). The oils, which only boil at high temperatures, are gasified and processed into methanol. About 5% of residues is the maximum amount to be obtained. The process runs pressure-free in a closed system thus generating practically no toxic emissions to the environment (Wanjek, 1995; Pearson, 1996).

Reduction process At Bremer Stahlwerke (steelworks in Bremer), plastic agglomerate is used as a substitute for heavy oil, one of the materials needed for operation of the blast furnace. During steel production in a blast furnace, the chemically bound oxygen must be separated from the iron fed into the furnace. Reduction, which is the removal of oxygen, is the reaction of carbon, carbon monoxide or hydrogen with oxygen. These reactions require energy input for it to take place, whereas combustion releases heat. The gases are formed when plastic is injected into the furnace at 2000°C, melts at the bottom of the blast furnace and undergoes abrupt gasification. Since plastic and oil have a very similar chemical composition, one kilogram of oil can be replaced by one kilogram of plastic in this process. As the gas migrates upwards through the long blast furnace shaft, more than 80% of the reduction potential of the gas produced from the plastic is utilized. A mixture of slightly combustible gas, carbon monoxide and steam, which is known as blast furnace gas, is obtained and used in the steelworks (Pearson, 1996).

Chemical recycling

Chemical conversion processes can be used for the recycling of plastic waste, but chemical recycling of polymers requires plastics of almost uniform chemical composition and sufficient purity. With regard to the potential cost, this type of recycling can be performed on an economical basis only with the more expensive engineering plastics, such as polyurethanes. The target of any chemical recycling process is to depolymerize polyurethane and recover those materials that can be reused. The numerous developed processes that are widely applicable are the following: hydrolysis, hydrogenation, pyrolysis, aminolysis, glycolysis, hydroglycolysis, chemolysis and ammonolysis. The processes differ greatly in terms of quality of the plastic feed, complexity of the process and final products. The plastic, however, must be adapted to chemical

recycling processes by liquefaction. A degradative extrusion has been suggested as a pretreating process for chemical recycling of plastic with satisfactory effects (Lentz and Mormann, 1992; Michaeli and Lackner, 1995; Seyfarth *et al.*, 1995; Marechal *et al.*, 1995; Cassey *et al.*, 1995).

Chemical plastic recycling processes may find application in recycling of PVC/PET blend where sorting operations are either not possible or prohibitively expensive. The advantage of such a process is the possibility to 'tailor' the end product to the application requirements. Since this approach is innovative, energy and material economics need further elaboration (Lusinchi *et al.*, 1998). Ammonolysis of polyurethanes has been reported in only a few studies among which the oldest is a patent dating from 1955. Two more patents, assigned to the McDonnell Douglas Corporation, claim ammonia to act as co-reagent in the alcoholysis of polyurethanes. Another representative example is ammonolytic cleavage of urethane and urea bonds of a polyurethane elastomer and flexible foam based on methylenebis (phenyl isocyanate) (MDI) and polyetherpolyol under supercritical conditions producing polyols, amines and substituted urea (Lentz and Mormann, 1992).

The glycolysis, as approached by 'waterilly', is carried out by charging compacted pellets into a stirred batch reactor containing diethylene glycol (DEG). A catalyst is added and the reactor is heated to 200°C. The pellets dissolve within 1 h and the reaction finishes in 2 h. The stirrer of the reactor is stopped and the reaction mixture is allowed to separate into two layers. The top layer consists of DEG and flexible polyol with a small quantity of impurities. The bottom layer consists primarily of DEG and aromatic compounds derived from the isocyanate in the foam. The two layers are separated for further processing. The top layer is washed with more DEG either in the batch reactor or in a liquid/liquid extraction column. After the final wash, DEG is removed by vacuum stripping yielding pure flexible polyol. Following purification, the obtained flexible polyol undergoes a split phase glycolysis so it can be used to replace virgin polyol completely. Propylene oxide (PO) is added to the bottom layer to form an aromatic polyol rich in DEG. This mixture is heated under vacuum to react and distill off any residual PO. Excess of DEG is also removed and is suitable for being reused at any stage of the process (Marechal *et al.*, 1995; Cassey *et al.*, 1995).

A new recycling technique has been developed which utilizes a natural solvent, d-limonene, to shrink expanded polystyrene (EPS). The new recycling system consists of EPS shrinking equipment and a recycling plant for separation of limonene solution. There are two types of EPS shrinking equipment developed: a mobile (truck) and a static EPS shrinking apparatus. The final product is polystyrene and not EPS because PS cannot be used to produce EPS by the thermal shrinking method (Noguchi *et al.*, 1998a, b, c).

Chemical recycling refers to the decomposition of the macromolecular structure to generate low molecular weight compounds. This is typically carried out under high temperature and in the presence of various types of catalysts. This approach consumes large amounts of energy and, in many cases, results in rather low value products. Probably the type of chemical recycling having the highest potential value involves depolymerization. In this case, the resulting monomer can then be utilized to regenerate more polymeric material (Burillo *et al.*, 2002).

Radiation technology

One technological barrier to polymer recycling is the incompatibility of different polymer types. When an attempt is made to mold a product using a polymer mixture, the materials typically form separate phases, resulting in poor properties. Another problem is degradation that may be present in the recycled material: properties are affected by changes in molecular structure caused by environmental factors during use, including UV light, thermal-oxidative processes, attack by pollutant gases, chemical interaction with liquid contents and others. Ionizing radiation offers unique possibilities for application to the problem of recycling polymers (Clough, 2001), due to its ability to cause cross-linking or scission of a wide range of materials without dissolving the sample. Possibilities for using radiation in recycling include:

- 1 enhancing the mechanical properties of recovered materials or blends
- 2 decomposition of polymers.

Radiation-included oxidation of PE prior to blending with recycled polyethyleneterephthalate (PET) was particularly beneficial; this enhanced the miscibility of the PE with the more polar PET (Burillo *et al.*, 2000).

Recycling of butyl rubber from inner tubes, using irradiation of cryogenically ground rubber crumb, is a commercial process in China (Yang *et al.*, 1998) which leaves few refining wastes. A limited amount of work has been reported on the use of radiation in chemical recycling (degradation) of polymers, yielding liquids of mixed composition for potential use in the petrochemical industry. Radiation can be useful in lowering the energy requirements for chemical recycling, as well as providing a means of controlling the nature of the products (Zhao *et al.*, 1996). Another study reported that when particles of radiation-cross-linked polyethylene were incorporated as an additive into a melt of uncross-linked polyethylene, an enhancement of elasticity was obtained (Matusevich and Krul, 1999; Matusevich *et al.*, 1999).

Radiation may potentially provide major benefit either for material recycling or for chemical recycling. A success in material recycling could constitute a major breakthrough in demonstrating an energy-efficient and economically attractive recycling technology. Due to its ability to penetrate solids, including opaque materials, and to induce chemistry in the solid phase, radiation may be uniquely suited to this purpose. Since radiation can also result in degradation of materials, depending on polymer type and environmental conditions, it may likewise be of utility in reducing energy costs by pretreatment of polymers to promote chemical recycling. Studies over the past two decades have established that irradiation can be very useful in the processing of polymer blends. Nearly all of this work has involved virgin (i.e. non-recycled) samples.

Polyethylene and polyamide The blends of polyethylenes with polyamide-6 (PA-6) are normally immiscible. The use of polyethylene (PE) (chemically functionalized by introduction of polar groups through irradiation) to prepare miscible blends with PA-6 has been reported by several workers. Spadaro *et al.* (1992, 1993, 1996) used this method to produce uniform blends of LDPE, HDPE and LLDPE (linear low-density polyethylene) with PA-6. Blending of LDPE with PA-6 led to lower values of tensile strength and

higher values of Izod impact strength (Valenza *et al.*, 1992, 1993). The irradiated blends with the stabilized morphology can then be conventionally processed, including conventional curing. These blends include NR/EPDM, SB/EPDM and BR/EPDM (NR, natural rubber; SBF, styrene-butadiene copolymer; BRF, polybutadiene). In another study, the processability of HMWPP/EPDM (HMWPP, high molecular weight polypropylene) blends was found to improve on irradiation (van Gisbergen, 1989) and the radiation-induced cross-links stabilized the morphology of this blend during injection molding. Gamma irradiation under an inert atmosphere of mixed compositions of PET and PP, which had been coextruded, was reported to show modest improvement in properties at low dose (50 kgy) as a result of material cross-linking, though the data were not conclusive; significantly degraded properties were seen at higher doses (300 kgy) (Revyakin *et al.*, 1999). The addition of agents which undergo cross-linking upon radiation exposure to compositions representing recovered waste materials, has been investigated. Mixed materials containing HDPE, PP and PS, with triallyl cyanurate (TAC) added, showed significant improvement in modulus at a dose of B200-350 kgy. Some positive effect was seen at 2% TAC; substantial improvement was found at 10% TAC (Fujii and Nomura, 1986). Czvikovszky and coworkers have reported a number of studies in which recycled, reinforced polymer systems were prepared using PP from reprocessed car bumpers (Czvikovszky *et al.*, 1999; Czvikovszky and Hargitai, 1999).

Gamma irradiation of butadiene-containing polymers in the presence of oxygen caused the material to exhibit a decrease in the onset temperature for mass loss, compared to unirradiated material or material irradiated in the absence of oxygen, when the samples were subjected to thermogravimetric analysis (TGA) (Schnabel *et al.*, 1999). There is a large and successful industry based on the radiation-degradation of Teflon powder, which renders the material able to be incorporated into inks, lubricants and other formulations (Lunkwitz *et al.*, 2000).

The issue of contamination on recycling

After sorting and washing, the waste polymer is likely to contain polymeric, particulate and chemical contaminants that might render the recycled material unsuitable for food applications. In general, recycled materials are not allowed to be used for food packaging applications. Food packaging in contaminated recycled materials is a serious problem and well understood scientifically (Franz *et al.*, 1994, 1997; Blakistone, 1994; Allen and Blakistone, 1995; Miltz *et al.*, 1997; Devliegehere *et al.*, 1998). The main drawback with old plastics comes from mass transfer that takes place during its previous use (Feigenbaun *et al.*, 1997; Yoda, 1999) and that old plastics, exhibiting potential contamination (by contact with harmful substances), cannot be in contact with the food (Perou *et al.*, 1999). One of the most interesting approaches consists of reusing the wasted plastic as the core of the new material, a layer of virgin polymer being placed between the recycled and the food (Feigenbaun *et al.*, 1997). Based on data of hundreds of known chemicals, the FDA considered the risk linked to the ingestion of an unknown chemical amounting to 10 ppb migrated substance (Bayer *et al.*,

1995). Usage of the abovementioned virgin polymer retards considerably the migration of the contaminant, which tends to be uniformly distributed through the bilayer packaging into the food. In view of the current state of the art only a predictive approach can be of help in deciding whether recycled plastics, although possibly polluted, can be used safely (Harmati *et al.*, 1995).

The marketing of unsafe materials is likely to be a barrier to more extensive exploitation of recycling of plastics. Exclusion of recycled materials from food packaging applications is likely to limit further advances in plastic recycling. Therefore, it is crucial for the industry to function within a frame of a clear and scientifically sound legislation. It has been suggested that the best strategy is to allocate virgin polymers to food contact uses and recycled materials to other applications. Many research groups are currently carrying out further investigation on this topic in order to ensure the veracity of such suggestions. Another proposal involves the use of multilayer PET according to which the recycled PET layer is 'sandwiched' between two layers of virgin PET. This technique is supposed to be efficient both for the protection of food and the environment as well. Therefore, the difficult problem of isolating any possible contaminants present in the recycled PET film is reduced to blocking the transport of the contaminants across the virgin layers.

US and EU regulators have tried to harmonize worldwide regulations concerning the use of recycled materials in food packaging. The Food and Drug Administration (FDA) in 1992 considered several suggested uses of recycled plastic for food packages and commented favorably on the use of recycled plastic in the following applications: expanded polystyrene for foam egg cartons; HDPE for grocery bags; PE and PP for harvesting crates; PET for quart- and pint-size baskets for fruits; regenerated PET for soda beverage bottles. Several processes for recycled PET for food packaging applications have been approved by regulatory agencies outside the USA. In 1992, the UK, the Ministry of Agriculture, Fisheries and Food (MAFF) approved the methanolysis process and the same process was approved by the European Union as well. Japan, in 1992, also approved methanolysis as a recycling process for PET that is going to be used for soft drink bottles. In 1993, Australia approved the multilayer proposal and was followed in 1994 by New Zealand, Sweden and Switzerland (Hope *et al.*, 1992; Moser and Dudler, 1995; Van Rijwijk, 1995; Kaiser, 1995).

Environmental impacts of waste management processes

Any recycling operations wishing to be considered responsible have to meet both the market and environmental requirements. Recycling seems to be the most popular option for the reduction of packaging waste. The EEC discussed a directive which should harmonize the different national regulations at the European level. Therefore, any assessment of plastic recycling processes has to take into account their environmental impacts and compatibility in addition to the actual recycling cost.

Consequently, the life cycle analysis is a system describing environmental and resource impacts of a product in its entire life cycle. It is a research instrument for any environmental parameters with the background of technical and economical specifications. For that purpose, the raw material, energy, emissions, wastewater and waste balances are carried out throughout the entire life cycle. An ecoprofile is based on the

same theory as life cycle assessment (LCA) but describes environmental and resource impact in a way which makes possible the ranking of different processes. The description of the system studied is the first step for preparing a life cycle analysis or an eco-profile. The next step is an inventory of all emissions and resource consumption caused by the processes in the life cycle and standardization of the emissions is the third step for a thorough life cycle assessment. Normalization of the equivalents is essential and is considered as a fourth step. The equivalents are normalized by dividing them with the average annual emission per inhabitant. For global effects, the equivalents are divided with the annual emission per inhabitant in the world and for regional effects the equivalents are divided with the annual emission per inhabitant in the region. The units of normalized equivalents are called person equivalents (PE). Only after normalization of the equivalents would it be possible to evaluate and speculate on the significance of the environmental contributions. LCA, sometimes, may include a fifth step which is the improvement analysis.

In Germany, within the frame of 'LCA of recycling and recovery of plastics waste packaging materials from households', three research institutes studied the various feedstock and mechanical recycling techniques with respect to their consumption of resources, the greenhouse effect, pollution and the production of municipal and hazardous waste. All steps involved in the recycling techniques and the fabrication of recycled products were thoroughly investigated. The most important conclusion reached in the LCA is that there is often more than one ecologically safe method for recovery of plastics. On the contrary, feedstock recycling, mechanical recycling or energy recovery techniques may be selected depending on the particular situation. From an ecological point of view, the most important is the best possible utilization of the chemical and physical properties and the energy content of the post-consumer plastics. All aspects of products should be taken into account so that there are no erroneous results. There have been many examples of published 'eco-balance' studies of various packaging systems. The German Institute for Market Research on Packaging studied the impacts of replacing PVC with other plastics. It was concluded that the total tonnage of single-layered films would remain the same were PVC to be replaced. However, because of the PVC superior barrier properties compared to other plastics, the amount of composite films would increase by 25%. This would result in an increase of waste production (almost 10% by weight) because composites are difficult to recycle while PVC is molded.

A joint application of Life Cycle Assessment and Energy Synthesis, named Energy Life Cycle Assessment, is shown to provide information about input and output material flows as well as about the environmental support to the system, in order to facilitate choices and policymaking towards Zero Emission Strategies and Techniques. Results show that increasing the complexity of the system as well as the use of co-products helps to achieve a better performance and an optimum use of available resources. The case study is only based in the performance comparison of two power plants, which does not entail all the possible ways for complexity increase. In fact, if a plant (or any other production system) is really integrated within the local productive structure, it is no longer just a point source of electricity, hot water and released chemicals. Other cycles

can be involved (water and wastewater, fuel from urban and biomass waste, use of sulfur from fuel purification, etc.), which could generate further non-negligible economic and environmental advantages. In order to do this, the input of information needed may take the form of landscape planning and alternative option exploration and lead to the construction of infrastructures capable of linking all the possible partners involved in co-product/raw material exchange and use. This new framework for the evaluation of production activities, the so-called Zero Emission Strategy, was found to be in very good agreement with Lotka-Odum's Maximum Power Principle in ecosystems. The two strategies/statements are, in principle, equivalent. Zero-emission technologies guide the way human-dominated systems can achieve maximum power output in times of scarce resources, like natural ecosystems have already learned to be over their evolutionary trajectories (Ulgiati *et al.*, 2006).

The Life Cycle Assessment approach was used to determine whether a recycle and re-use strategy for plastics-based packaging system that substantially reduces the quantity of waste to landfill would also reduce its overall environmental burden. The following conclusions were deduced:

- 1 the life cycle impacts in all categories examined were less for the proposed EPS-HIPS/PE shrink-wrap packaging than for a present EPS/PE packaging. This is due to its lighter weight and also to the innovative recycling/re-use strategy for the new packaging system
- 2 the life cycle oil consumption for the proposed EPS-HIPS/PE shrink-wrap packaging is about one-third less than the present EPS/PE shrink-wrap packaging. However, for both packagings, the consumption of oil accounts for a relatively small proportion of the over-all energy consumption
- 3 both packaging options contribute to photochemical oxidant problems in Sydney and Melbourne. However, the EPS/PE packaging contributes more nitrogen oxides and volatile hydrocarbon precursors than the proposed EPS-HIPS/PE packaging and will therefore have a greater marginal impact
- 4 recycling or, better still, re-use of plastic products can significantly reduce the energy required across the life cycle because the high energy inputs needed to process the requisite virgin materials greatly exceeds the energy needs of the recycling or re-use process steps (Ross and Evans, 2003).

Therefore, if a product requires a large input of energy derived from fossil fuels during primary production, as is the case for plastic-based products derived from virgin materials, then recycling is likely to reduce a product system's environmental burden (Patel *et al.*, 2000). It was also found that the energy consumed during transportation is negligible when compared to the overall energy consumption of the system. This is true even with the additional transport needs of the recycling and re-use steps. This is important, because transport emissions are often cited as a reason for not pursuing recycling possibilities (Pearce, 1997). The raw material, energy, emissions, wastewater and waste balances are carried out throughout the total life cycle as presented in Figure 15.20 and Figure 15.21.

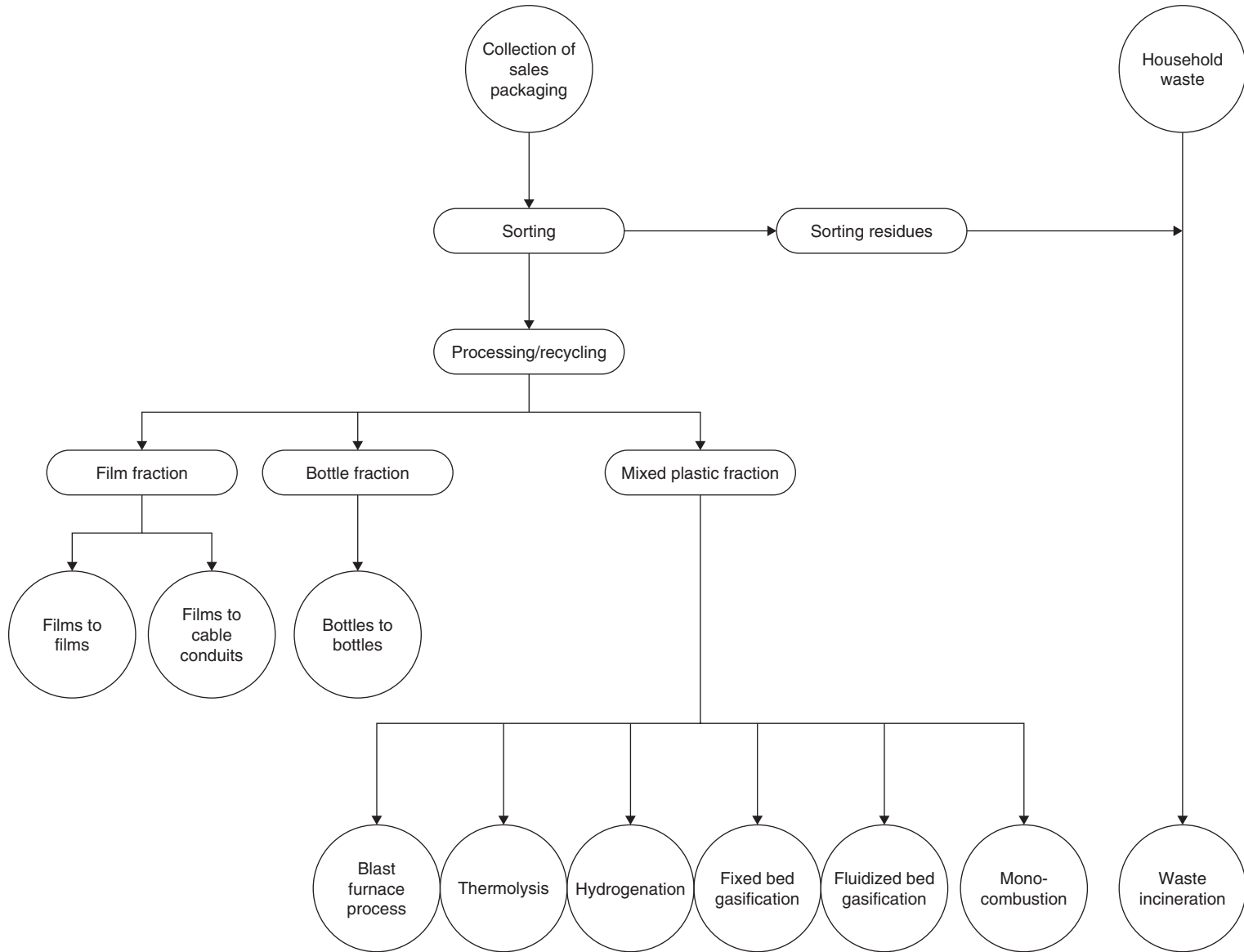

Figure 15.20 Scope of life cycle analysis for mechanical and feedstock recycling processes as well as energy recovery techniques

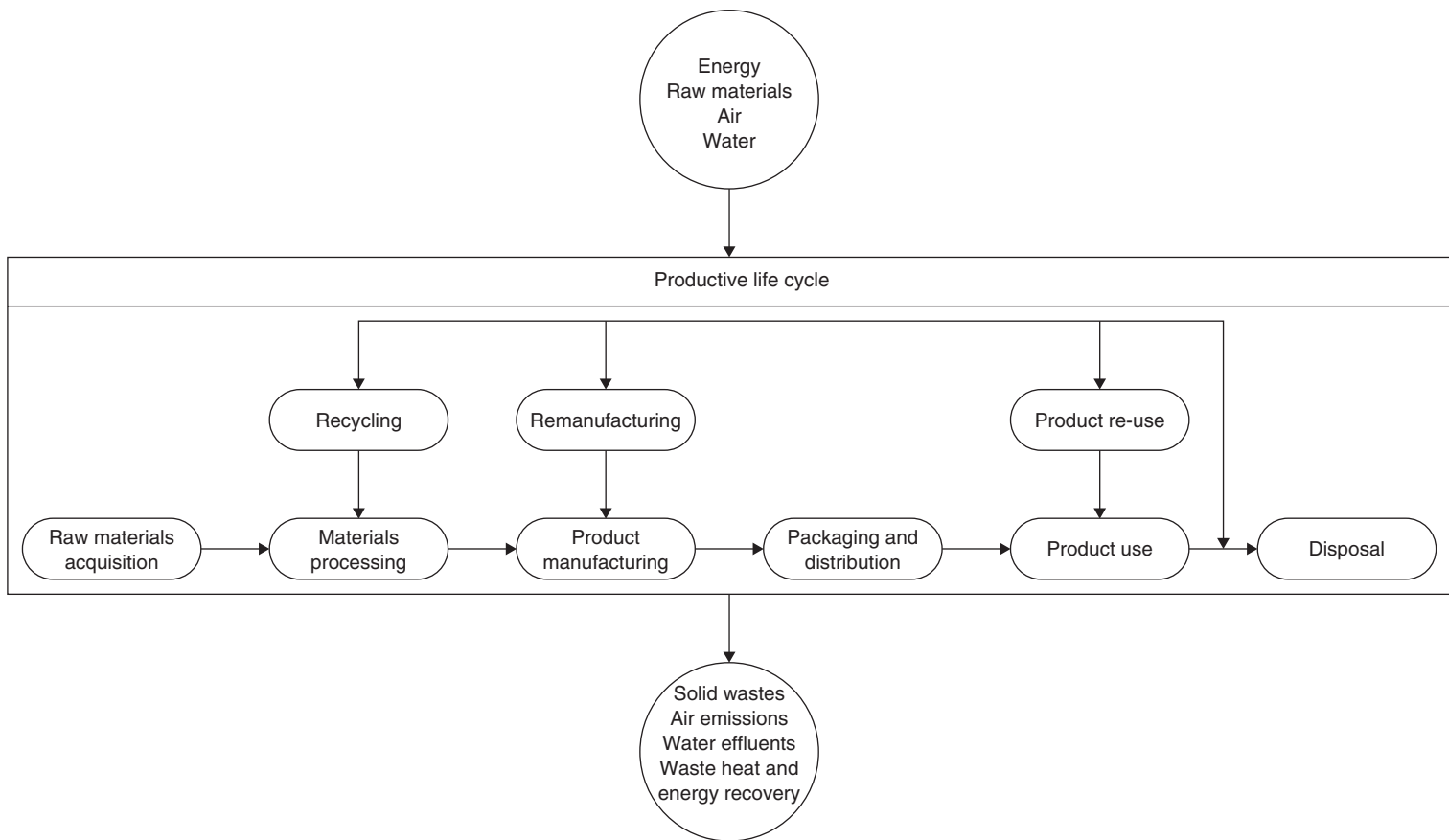

Figure 15.21 The life cycle of a product, including clarification of the terms re-use and recycling

References

Scientific references

- Adams, K.S., Even, J.C. and Blewett, T.J. (1996). MARTIN: A Midwest Regional Database for Recycling Materials from Post-Consumer Solid Waste. *Resource Conservat Recycl* **17**, 153–167.
- Aiba, S., Izume, M., Minoura, N. and Fujiwara, Y. (1986). Chitosan-based membranes for separation processes. In *Chitin in nature and technology* (R.A.A. Muzzarelli, C. Jeuniaux and G.M. Gooday, eds), pp. 396–398. Plenum, New York.
- Albertsson, C.A., Barenstedt, C. and Karlsson, S. (1994). Abiotic degradation products from enhanced environmentally degradable polyethylene. *Acta Polym* **45**, 97–103.
- Albertsson, A.C. and Karlsson, S. (1994). Chemistry and biochemistry of polymer biodegradation. In *Chemistry and technology of biodegradable polymers* (G.J.L. Giffin, ed.), pp. 7–17. Blackie Academic and Professional, Glasgow.
- Albertsson, A.C. and Ranby, B. (1979). Biodegradation of synthetic polymers. IV. The $^{14}\text{CO}_2$ method applied to linear polyethylene containing a biodegradable additive. *J Appl Polym Sci* **35**, 423–430.
- Allen, B. and Blakistone, B. (1995). Assessing reclaimed processes for plastics recycling. American Chemical Society Symposium Series 609, Washington, DC.
- Alter, H. (1997). Industrial recycling and the Basel Convention. *Resources Conservat Recycl* **19**, 29–53.
- Ambrose, C.A., Hooper, R., Potter, A.K. and Singh, M.M. (2002). Diversion from landfill: quality products from valuable plastics. *Resources Conservat Recycl* **36**, 309–318.
- Anon. (1990). Packaging waste management. *Food Technol* **6**, 98–101.
- Anon. (1994). The role of recycling in integrated solid waste management to the year 2000. Franklin Associates.
- Anon. (1995a). Disposal of waste refractories. *Glass Technol* **36**(2), 39.
- Anon. (1995b). Funding technical innovation in energy efficiency. *Glass Technol* **36**(2), 38–39.
- Anon. (1998). State of garbage in America report. *Biocycle* April.
- APME. (1999). *Plastics Recycling in Perspective*, May 19.
- Aragade, A.B. and Peppas, N.A. (1993). Preparation and characterization of novel biodegradable tri- and tetra-acrylate intermediates. *Polym Bull* **31**, 401–407.
- Arvanitoyannis, I., Biliaderis, C., Ogawa, H. and Kawasaki, N. (1998). Biodegradable films made from low density polyethylene (LDPE) and rice starch for food packaging uses. Part 1. *Carbohydr Polym* **36**(2/3), 89–104.
- Arvanitoyannis, I. and Blanshard, J.M.V. (1993). Anionic copolymers of octanelactam with laurolactam (nylon 8/12 copolymers). VII. Study of diffusion and permeation of gases in undrawn and uniaxially drawn (conditioned at different relative humidities) polyamide films. *J Appl Polym Sci* **47**, 1933–1959.
- Arvanitoyannis, I., Kalichevsky, M., Blanshard, J.M.V. and Psomiadou, E. (1994a). Study of diffusion and permeation of gases in undrawn and uniaxially drawn films made from potato and rice starch conditioned at different relative humidities. *Carbohydr Polym* **24**, 1–15.

- Arvanitoyannis, I., Nakayama, A., Kawasaki, N. and Yamamoto, N. (1995a). Novel star shaped polylactide with glycerol using stannous octoate or tetraphenyl tin as catalyst: 1. Synthesis, characterization and study of their biodegradability. *Polymer* **36**, 2947–2956.
- Arvanitoyannis, I., Nakayama, A., Kawasaki, N. and Yamamoto, N. (1995b). Novel polylactides with aminopropanediol aminohydroxymethylpropanediol using stannous octoate or tetraphenyl tin as catalyst: 2. Synthesis, characterization and study of their biodegradability. *Polymer* **36**, 2271–2279.
- Arvanitoyannis, I., Nakayama, A., Kawasaki, N. and Yamamoto, N. (1994b). Synthesis and properties of biodegradable copolyesteramides: Nylon 6,6/e-caprolactone copolymers, I. *Angew Makromol Chem* **222**, 111–123.
- Arvanitoyannis, I., Nakayama, A., Kawasaki, N. and Yamamoto, N. (1995c). Synthesis and properties of novel biodegradable oligoesteramides based on sebacic acid, octadecanedioic acid, 1,6-hexane diamine and e-caprolactone. Part 2. *Polymer* **36**, 857–866.
- Arvanitoyannis, I., Nakayama, A., Psomiadou, E., Kawasaki, N. and Yamamoto, N. (1996a). Synthesis and degradability of a novel aliphatic polyester based on L-lactide and sorbitol: 3. *Polymer* **37**, 651–660.
- Arvanitoyannis, I., Nikolaou, E. and Yamamoto, N. (1993). Novel biodegradable copolyamides based on adipic acid, 1,6-hexane diamine, a-amino acids: synthesis and study of properties. Part I. In *Proceedings of the Third International Workshop on Biodegradable Polymers* (Y. Doi and K. Fukuda, eds), pp. 562–569. Elsevier, Amsterdam.
- Arvanitoyannis, I., Nikolaou, E. and Yamamoto, N. (1994c). Novel copolyamides based on adipic acid, isophorone diamine and a-amino acids. 3: Synthesis, study of properties and evaluation of their biodegradability for food packaging applications. *Angew Makromol Chem* **221**, 67–90.
- Arvanitoyannis, I., Nikolaou, E. and Yamamoto, N. (1994d). Novel biodegradable copolyamides based on adipic acid, bis(para-aminocyclohexyl) methane and several a-amino acids: Synthesis, characterization and study of their degradability for food packaging applications; Part 4. *Polymer* **35**, 4678–4689.
- Arvanitoyannis, I., Nikolaou, E. and Yamamoto, N. (1995d). New copolyamides based on adipic acid, aliphatic diamines and amino acids: Synthesis, characterization and biodegradability. 5. *Macromol Chem Phys* **196**, 1129–1151.
- Arvanitoyannis, I., Psomiadou, E., Biliaderis, C., Ogawa, H., Kawasaki, N. and Nakayama, A. (1997). Biodegradable films made from low density polyethylene (LDPE), ethylene acrylic acid (EAA), polycaprolactone (PCL) and wheat starch for food packaging applications; Part 3. *Stärke/Starch* **49**, 306–322.
- Arvanitoyannis, I. and Psomiadou, E. (1994). Composition of anionic (co)polyamides (nylon 6/nylon 12) with short glass E-fibres – preparation and properties. *J Appl Polym Sci* **51**, 1883–1900.
- Arvanitoyannis, I., Psomiadou, E. and Nakayama, A. (1996b). Edible films made from sodium caseinate, starches, sugars or glycerol, Part 1. *Carbohydr Polym* **31**, 179–192.
- Arvanitoyannis, I., Psomiadou, E., Yamamoto, N., Nikolaou, E. and Blanshard, J.M.V. (1995e). Novel copolyamides based on adipic acid, 1,6 hexane diamine and a-amino

- acids: 2. Study of properties and their biodegradability for food packaging applications. *Polymer* **36**, 2957–2967.
- Arvanitoyannis, I., Psomiadou, E., Yamamoto, N. and Blanshard, J.M.V. (1995f). Composites of novel biodegradable copolyamides based on adipic acid, 1,6 hexane diamine and L-proline with short E-glass fibres: I. Preparation and properties. *Polymer* **36**, 493–503.
- Arvanitoyannis, I., Psomiadou, E., Yamamoto, N. and Blanshard, J.M.V. (1995g). Composites of novel biodegradable copolyamides based on adipic acid, 1,6 hexane diamine and L-glycine with short E-glass fibres: I. Preparation and properties. *J Appl Polym Sci* **56**, 1045–1058.
- Arvanitoyannis, I.S. (1999). Totally and partially biodegradable polymer blends based on natural and synthetic macromolecules: preparation, physical properties and potential as food packaging materials. *J M S Rev Macromol Chem Phys* **C39**(2), 205–271.
- Arvanitoyannis, I.S. and Bosnea, L.A. (2001a). Recycling of polymeric materials used for food packaging: current status and perspectives. *Food Rev Int* **17**(3), 291–346.
- Arvanitoyannis, I.S. and Bosnea, L.A. (2001b). Recycling glass used for food packaging. 1st Balkan Conference Proceedings of Glass Recycling, University of Thessaly, Volos, pp. 572–580.
- Asha Poorna, C. and Prema, P. (2007). Production of cellulase-free endoxylanase from novel alkalophilic thermotolerant *Bacillus pumilis* by solid-state fermentation and its application in wastepaper recycling. *Bioresource Technol* **98**, 485–490.
- Azuma, Y., Yoshie, N., Sakurai, M., Inoue, Y. and Chujo, R. (1992). Thermal behaviour and miscibility of poly(3-hydroxybutyrate)/poly(vinyl alcohol) blends. *Polymer* **33**, 4763–4767.
- Baldwin, E.A., Nisperos-Carriedo, M.O. and Baker, R.A. (1995). Use of edible coatings to preserve quality of lightly (and slightly) processed products. *Crit Rev Food Sci Nutr* **35**, 509–524.
- Ball, R. and Unsworth, A. (1995). Markets for post consumer plastics waste. In *Recovery, Recycling and Reintegration*, Collected Papers of the R'95 International Congress, Geneva, Switzerland.
- Banks, C.J. (2004). Analysis of energy footprints associated with recycling of glass and plastic – case studies for industrial ecology. *Ecol Model* **174**, 175–189.
- Barlow, D.K. (1994). Glass recycling. *Glass Technol* **35**(2), 56–57.
- Baroulaki, I., Karakasi, O., Pappa, G., Tarantili, P.A., Economides, D. and Magoulas, K. (2006). Preparation and study of plastic compounds containing polyolefins and post used newspaper fibres. Composites Part A: Applied Science & Manufacturing **37**(10), 1613–1625.
- Barron, W.F. and Ng, G.T.L. (1996). An assessment methodology for environmental policy instruments: an illustrative application to solid wastes in Hong Kong. *J Environ Manage* **48**, 283–298.
- Bastian, C., Sandham, R. and Weigand, E. (1995). Polyurethanes recycling – a European perspective. In *Recovery, Recycling, and Reintegration*, Collected Papers of the R'95 International Congress, Geneva, Switzerland.

- Bayer, F.L., Myers, D.V. and Gage, M. (1995). Technical and regulatory aspects of recycling PET for food use. In *Recovery, Recycling, and Reintegration*, Collected Papers of the R'95 International Congress, Geneva, Switzerland.
- Beattie, S. and Kerell, E. (1995). Impact of legislation on hazardous household waste collection initiatives in Europe. In *Recovery, Recycling, and Reintegration*, Collected Papers of the R'95 International Congress, Geneva, Switzerland.
- Beffa, T., Blanc, M., Lott-Fischer, J., Lyon, P-F., Marilley, L. and Aragno, M. (1995). Composting: a microbiological process. In *Recovery, Recycling, and Reintegration*, Collected Papers of the R'95 International Congress, Geneva, Switzerland.
- Begley, T.H. and Hollifield, H.C. (1993). Recycled polymers in food packaging: migration considerations. *Food Technol* **11**, 109–112.
- Bera, S. and Jedlinski, Z. (1993). Block segmented polymers. A new method of synthesis of copoly(amide-ester)-ester polymer. *J Polym Sci Part A Polym Chem* **31**, 731–739.
- Bergner, R. (1995). Packaging development concerning ecological aspects. In *Recovery, Recycling, and Reintegration*, Collected Papers of the R'95 International Congress, Geneva, Switzerland.
- Bertin, S. and Robin, J.J. (2002). Study and characterization of virgin and recycled LDPE/PP blends. *Eur Polym J* **38**, 2255–2264.
- Biod, A., Probert, E.J. and Jones, C. (1995). Numerical, modeling and optimization of the cost of house-to-house collection recycling schemes. In *Recovery, Recycling, and Reintegration*, Collected Papers of the R'95 International Congress, Geneva, Switzerland.
- Blakistone, B. (1994). The fourth R. *Food Process March*.
- Blanc, M., Beffa, T., Lott Fisher, J. and Aragno, M. (1995). Chemolitho-autotrophic and heterotrophic thermophilic bacteria isolated from hot compost piles. In *Recovery, Recycling, and Reintegration*, Collected Papers of the R'95 International Congress, Geneva, Switzerland.
- Bor, Y.J., Chien, Y.L. and Hsu, E. (2004). The market-incentive recycling system for waste packaging containers in Tawain. *Environ Sci Pol* **7**, 509–523.
- Brandrup, J. (1992). Prerequisites for successful recycling of polymer waste. *Makromol Chem Macromol Symp* **57**, 57–74.
- Brown, D. (1993). Plastic packaging of food products: the environmental dimension. *Trends Food Sci Technol* **4**, 294–300.
- Brunner, M. and Frey, R. (1995). Recovery of materials through thermal treatment of MSW. In *Recovery, Recycling, and Reintegration*, Collected Papers of the R'95 International Congress, Geneva, Switzerland.
- Burillo, G., Clough, R.L., Czvikovszky, T., Guven, O. *et al.* (2002). Polymer recycling: potential application of radiation technology. *Radiat Phys Chem* **64**, 41–51.
- Burillo, G., Herrera, P., Martinez, S., Vazquez, M. and Adem, E. (2000). Work presented at the IAEA Consultant's Meeting, Gifsur-Yvette, France, 19–21 September.
- Butler, J. and Hooper, P. (2005). Dilemmas in optimizing the environmental benefit from recycling: a case study of glass container waste management in the UK. *Resources Conservat Recycl* **45**, 331–335.
- Buzzini, A.P. and Pires, E.C. (2007). Evaluation of an upflow anaerobic sludge blanket reactor with partial recirculation of effluent used to treat wastewaters from pulp and paper plants. *Bioresource Technol* **98**(9), 1838–1848.

- Calamius, B. and Stahlberg, R. (1998). Thermal waste treatment: a better approach. *Chemtech* October, 40–43.
- Caluori, A. (1995). Thermal recycling of alternative materials at BCU. In *Recovery, Recycling, and Reintegration*, Collected Papers of the R'95 International Congress, Geneva, Switzerland.
- Campbell, A.J. (1994). The recycling, reuse and disposal of food packaging materials: a UK perspective. In *Food Packaging & Preservation* (M. Mathlouthi, ed.). Blackie Academic & Professional, Glasgow.
- Carlsson, K. B. (1995). Energy from waste is a important part of the natural ecocycle. In *Recovery, Recycling, and Reintegration*, Collected Papers of the R'95 International Congress, Geneva, Switzerland.
- Cassey, M., Hicks, D.A., Hopper, J.F.G. and Hein, D.E. (1995). Chemical recycling – the price of success. In *Recovery, Recycling, and Reintegration*, Collected Papers of the R'95 International Congress, Geneva, Switzerland.
- Castle, L. (1994). Recycled and reused plastics for food packaging? *Packaging Technol Sci* **7**, 291–297.
- Cerrai, P. and Tricoli, M. (1993). Block copolymers from L-lactide and poly(ethylene glycol) through a non-catalyzed route. *Makromol Chem Rapid Commun* **14**, 529–538.
- Chang, H.N., Kim, Y.C., Lee, S.Y. and Kim, B.S. (1995). Current status of biodegradable plastics in Korea: research, commercial production and government policy. In *Recovery, Recycling, and Reintegration*, Collected Papers of the R'95 International Congress, Geneva, Switzerland.
- Chen, X., Gonsalves, K.E. and Cameron, J.A. (1993). Further studies on biodegradation of aliphatic poly(ester-amides). *J Appl Sci* **50**, 1999–2006.
- Chiellini, E. (1994). Status of government policy, regulation and standards on the issue of biodegradable plastic materialism in Italy. In *Biodegradable Plastics & Polymers* (Y. Doi, and K. Fukuda, eds). Elsevier, Amsterdam.
- Chiellini, E. and Solaro, R. (1992). New synthetic functional polyesters. *Macromol Chem Macromol Symp* **54/55**, 483–494.
- Choudhary, M.K. and Huff, N.T. (1997). Mathematical modelling in the glass industry: an overview of status and needs. *Glastech Ber Glass Sci Technol* **70**(12), 363–370.
- Christensen, R. (1979). *Mechanics of composite materials*. John Wiley, New York.
- Chu, C.C.J. (1981). Hydrolytic degradation of polyglycolic acid: tensile strength and crystallinity study. *J Appl Polym Sci* **26**, 1727–1734.
- Chudnovsky, A., Shulkin, Y., Baron, D. and Lin, K.P. (1995). New method of lifetime prediction for brittle fracture of polyethylene. *J Appl Polym Sci* **56**, 1465–1478.
- Clough, R.L. (2001). High-energy radiation and polymers: a review of commercial processes and emerging applications. *Nucl Inst Meth Phys Res* **B185**, 8–33.
- Cook, W.G.A. (1995). Disposal of packaging. *Glass Technol* **36**(1), 2–4.
- Czikovszky, T. and Hargitai, H., (1999). Compatibilization of recycled polymers through radiation treatment. *Radiat Phys Chem* **55**, 727–730.
- Czikovszky, T., Hargitai, H., Racz, I. and Csukat, G. (1999). Reactive compatibilization in polymer alloys, recyclates and composites. *Nucl Instrum Meth* **B150**, 190–191.
- Dahlbo, H., Ollikainen, M., Peltola, S., Myllymaa, T. and Melanen, M. (2007). Combining ecological and economic assessment of options for newspaper waste management. *Resources Conservat Recyc* **51**(1), 42–63.

- Dalmijn, W.L., Maltha, C., van Houwelingen, J.A. and Frisch, H. (1995). New developments in automated sorting and automated quality control systems for the glass recycling industry. *Recovery, recycling, and reintegration: Collected papers of the R'95 International Congress*, Geneva, Switzerland.
- Daniliuc, L. and David, C. (1996). Intermolecular interactions in blends of poly(vinyl alcohol) with poly(acrylic acid): 2. Correlation between the states of sorbed water and the interactions in homopolymers and their blends. *Polymer* **37**, 5219–5227.
- Dannheim, H. and Hadrich, H. (1998). Quality assurance of sintered refractories through nondestructive testing with microwaves. *Glastech Ber Glass Sci Technol* **71**(8), 223–229.
- Dascalopoulos, E., Badr, O. and Probert, S.D. (1998). An integrated approach to municipal solid waste management. *Resources Conservat Recycl* **24**, 33–50.
- Dasgupta, A.S. and Sharma, R. (1995). The sixty years solution learning to manage waste from the illiterate city managers. In *Recovery, Recycling, and Reintegration, Collected Papers of the R'95 International Congress*, Geneva, Switzerland.
- De Stefanis, P., Di Palo, C., Vehich, G. and Zagaroli, M. (1995). Energy recovery from used plastics by gasification. In *Recovery, Recycling, and Reintegration, Collected Papers of the R'95 International Congress*, Geneva, Switzerland.
- Den Dunnen, W.F.A., Schakenraad, J.M., Zondervan, G.J., Pennings, A.J., Van der Lei, B. and Robinson, P.H. (1993). A new PLLA/PCL copolymer for nerve generation. *J Mater Sci Mater Med* **4**, 521–525.
- Devliegehere, F., De Meulenaer, B., Demyttenaere, J. and Huygherbaert, A. (1998). Evaluation of recycled HDPE milk bottles for food applications. *Food Addit Contam* **15**(3), 336–345.
- Diaz, R. and Warith, M. (2006). Life-cycle assessment of municipal solid wastes: development of the WASTED model. *Waste Manage* **26**, 886–901.
- Dodbiba, G., Haruki, N., Shibayama, A., Miyazaki, T. and Fujita, T. (2002). Combination of sink-float separation and flotation technique for purification of shredded PET-bottle from PE or PP flakes. *Int J Miner Process* **65**, 11–29.
- Dodbiba, G., Sadaki, J., Okaya, K., Shibayama, A. and Fujita, T. (2005). The use of air tabling and triboelectric separation for separating a mixture of three plastics. *Min Engine* **18**, 1350–1360.
- Duales System Deutschland AG. (2004). Available from: <http://www.guener-punkt.de.2004>.
- Duales System Deutschland GmbH. (1996). Changes and developments – lastic recycling today.
- Edlinger, A. (1995). HSRI: an innovative process to transform slag from waste incineration into useful mineral additives. In *Recovery, Recycling, and Reintegration, Collected Papers of the R'95 International Congress*, Geneva, Switzerland.
- Eisenreich, N., Herz, J., Kull, H. and Mayer, W. (1995). Fast on line identification of plastic materials by near infrared spectroscopy. In *Recovery, Recycling, and Reintegration, Collected Papers of the R'95 International Congress*, Geneva, Switzerland.
- El-Fadel, M., Findikakis, A.N. and Leck, J.O. (1997). Environmental impacts of solid waste landfilling. *J Environ Manag* **50**, 1–25.
- El Ghaouth, A., Arul, J., Ponnampalalan, R. and Boulet, M. (1991). Chitosan coating effect on storability and quality of fresh strawberries. *J Food Sci* **56**, 1618–1624.

- El Ghaouth, A., Arul, J. and Ponnampalalan, R. (1991). Use of chitosan coating to reduce water loss and maintain quality of cucumber and bell pepper fruits. *J Food Proc Pres* **15**, 359–368.
- EPA (Environmental Protection Agency). (2002). *Solid waste management and greenhouse gases. A life-cycle assessment of emissions and sinks*, 2nd edn. Contract EPA530-R-02-006, US Environmental Protection Agency. Washington, DC.
- Eschke, R. (1990). Trends in packaging, European legislation and environmental matters. *Packaging Technol Sci* **3**, 65–66.
- Eulalio, A., Capiati, N. and Barbosa, N. (2000). Municipal plastic waste: alternatives for recycling with profit. Presented at the *Annual Technical Conference, Society of plastics engineers*, Dallas, TX. Available from: <http://www.sperecycling.org/PDF%20Files/0805.PDF>.
- Faaij, A., Hekkert, M., Worrell, E. and Van Wijk. (1998). Optimization of the final waste treatment system in the Netherlands. *Resources Conservat Recycl* **22**, 47–82.
- Fagagnolo, J.B., Ruiz-Navas, E.M., Simon, M.A. and Martinez, M.A. (2003). Recycling of aluminium matrix composite chips by pressing and hot extrusion. *J Mater Process Technol* **143–144**, 792–795.
- Fahrni, H.P. (1995). Economical instruments in the Swiss legislation for an integrated resources management. In *Recovery, Recycling, and Reintegration*, Collected Papers of the R'95 International Congress, Geneva, Switzerland.
- Feigenbaum, A., Laoubi, S. and Vergnaud, J.M. (1997). Kinetics of pollutant from a recycled polymer through a functional barrier: recycling plastics for food packaging. *J Appl Polym Sci* **66**, 597–607.
- Franz, R., Huber, M. and Piringner, O. (1997). Presentation and experimental verification of a physico-mathematical model describing the migration across functional barrier layers into foodstuffs. *Food Addit Contam* **14**(6&7), 627–640.
- Franz, R., Huber, M. and Piringner, O.G. (1994). Testing and evaluation of recycled plastics for food packaging use – possible migration through a functional barrier. *Food Addit Contam* **11**(43), 479–496.
- Fujii, Y. and Nomura, M. (1986). Reforming of plastics waste by gamma-irradiation. *Bull Res Lab Nucl Reactor* **20**, 72–74.
- Furda, I. and Brine, C.J. (1990). *New developments in dietary fiber*. Plenum, New York.
- Gajdos, R. (1995). Composting in static bioreactors in laboratory 1. Effects of insulation on temperature and pH. In *Recovery, Recycling, and Reintegration*, Collected Papers of the R'95 International Congress, Geneva, Switzerland.
- Gant, D. (1999). Recycling and market power: a more general model and re-evaluation of the evidence. *Int J Indust Organiz* **17**, 59–80.
- Garforth, A.A., Ali, S., Hernandez-Martinez, J. and Akah, A. (2004). Feedstock recycling of polymer wastes. *Curr Opin Solid State Mater Sci* **8**, 419–425.
- Gaymans, R.J. and De Haan, J.L. (1993). Segmented copolymers with poly(esteramide) units of uniform length: synthesis. *Polymer* **34**, 4360–4364.
- Gellenbeck, K. (1995). Collecting schedule, hygiene and smell in the field of refuse removal. In *Recovery, Recycling, and Reintegration*, Collected Papers of the R'95 International Congress, Geneva, Switzerland.

- Gennadios, A., Brandenburg, A.H., Weller, C.L. and Testin, R.F. (1993a). Effect of pH on properties of wheat gluten and soy protein isolate films. *J Agricult Food Chem* **41**, 1835–1839.
- Gennadios, A., Park, H.J. and Weller, C.L. (1993b). Relative humidity and temperature effects on tensile strength of edible protein and cellulose ether films. *Trans ASAE* **36**, 1867–1872.
- Gennadios, A., Weller, C.L. and Testin, R.F. (1993c). Property modification of edible wheat gluten films. *Trans ASAE* **36**, 465–470.
- Gennadios, A., Weller, C.L. and Testin, R.F. (1993d). Modification of physical and barrier properties of edible wheat gluten-based films. *Cereal Chem.*, **70**, 426–429.
- Gennadios, A., Weller, C.L. and Testin, R.F. (1993e). Temperature effect on oxygen permeability of edible protein-based films. *J. Food Sci.*, **58**, 212–214, 219.
- Gennadios, A. and Weller, C.L. (1990). Edible films and coating from wheat and corn proteins. *Food Technol* **44**, 63–69.
- Gente, V., La Marca, F., Lucci, F., Massacci, P. and Pani, E. (2004). Cryo-comminution of plastic waste. *Waste Manage* **24**, 663–672.
- Giffin, G.J.L. (1994). *Chemistry and technology of biodegradable polymers*, pp. 135–149. Blackie Academic and Professional, London.
- Gijpa, D.W. and Pennings, A. (1994a). Copolymers of L-lactide. 1. Synthesis, thermal properties and hydrolytic degradation. *Makromol Chem Phys* **195**, 1633–1647.
- Gijpa, D.W. and Pennings, A. (1994b). Copolymers of L-lactide. 2. Mechanical properties. *Makromol Chem Phys* **195**, 1649–1663.
- Gilbert, R. (1998). *Solid Waste Management*, October/November.
- Gilmore, M.W. and Hayes, T.L. (1996). Glass beverage bottles. *The McGraw-Hill recycling handbook*. McGraw-Hill, New York.
- Giovanetto, S.H., Scharf, M.W. and Edwards, S. (1995). Baxter's closed loop hospital recycling program. In *Recovery, Recycling, and Reintegration*, Collected Papers of the R'95 International Congress, Geneva, Switzerland.
- Godzinska-Jurczak, M. and Bartosiewicz, A. (2001). The RECAL foundation programme; an example of ecological education in Poland. *Resources Conserv Recyc* **34**, 19–31.
- Goheen, S.M. and Wool, R.P. (1991). Degradation of polyethylene-starch blends in soil. *J Appl Polym Sci* **42**, 2691–2701.
- Gonostajski, J., Chmura, W. and Gonostajski, Z. (2002). Bearing materials obtained by recycling of aluminium and aluminium bronze chips. *J Mater Process Technol* **125–126**, 483–490.
- Gonostajski, J., Marciniak, H. and Matuszak, A. (2000). New methods of aluminium and aluminium-alloy chips recycling. *J Mater Process Technol* **106**, 34–39.
- Gonostajski, J., Marciniak, H., Matuszak, A. and Samuel, M. (2001). Aluminium-ferrochromium composites produced by recycling of chips. *J Mater Process Technol* **119**, 251–256.
- Gonsalves, K.E., Chen, X. and Cameron, J.A. (1993). Degradation of non-alternating poly(esteramides). *Macromolecules* **25**, 3309–3312.
- Goodman, I. (1984). Copolyesteramides – IV: anionic copolymers of e-caprolactam with e-caprolactone. *Eur Polym J* **20**, 548–557.

- Goodman, I. and Sheahan, R.J. (1990a). Copolyesteramides – V. Hexamethylene adipamide/hexamethylene adipate random and ordered copolymers: preparation and general properties. *Eur Polym J* **26**, 1081–1088.
- Goodman, I. and Sheahan, R.J. (1990b). Copolyesteramides – V. Hexamethylene adipamide/hexamethylene adipate random and ordered copolymers: Molecular aspects. *Eur Polym J* **20**, 1089–1095.
- Goodman, I. and Vachon, R.N. (1984a). Copolyesteramides – I: anionic copolymers of e-caprolactam with e-caprolactone. *Eur Polym J* **20**, 241–248.
- Goodman, I. and Vachon, R.N. (1984b). Copolyesteramides – II: anionic copolymers of e-caprolactam with e-caprolactone. *Eur Polym J* **20**, 529–537.
- Goodman, I. and Vachon, R.N. (1984c). Copolyesteramides –III: anionic copolymers of e-caprolactam with e-caprolactone. *Eur Polym J* **20**, 539–548.
- Gordon, J. (1991). *Joint ventures*. A Waste Watch/Larac Publication.
- Gould, J.M., Gordon, S.H., Dexter, L.B. and Swanson, C.L. (1990). Biodegradation of starch containing plastics. In *Agricultural and synthetic polymers. biodegradability and utilization* (J.E. Glass and G. Swift, eds), pp. 65–75. AC Symposium Series 433, American Chemical Society, Washington, DC.
- Guilbert, S. and Biquet, B. (1989). in *L'emballage des denrees alimentaires de grande consommation* (J.L. Multon and G. Bureau, eds), pp. 320–325. Lavoisier, Paris.
- Guilbert, S. and Gontard, N. (1995). Edible and biodegradable food packaging. In *Foods and Packaging Materials* (P. Ackerman, M. Jaegerstad, and T. Ohlsson, eds), pp. 159–168. Royal Society of Chemistry, Oxford.
- Guilbert, S., Gontard, N. and Gorris, G.M. (1996). Prolongation of the shelf life of perishable food products using biodegradable films and coatings. *Lebensm Wiss Technol* **29**, 10–17.
- Guneklee, E. and Kubocz, T. (1995). From biowaste to potting soil. In *Recovery, Recycling, and Reintegration*, Collected Papers of the R'95 International Congress, Geneva, Switzerland.
- Gupta, S., Mohan, K., Prasad, R., Gupta, S. and Kansal, A. (1998). Solid waste management in India: options and opportunities. *Resources Conservat Recycl* **24**, 137–154.
- Gutmann, R. (1996). Thermal technologies to convert solid waste residuals into technical glass products. *Glastech Ber Glass Sci Technol* **69**(9), 285–299.
- Hager, L.B. (1995). Recycling collection in Connecticut towns and cities. In *Recovery, Recycling, and Reintegration*, Collected Papers of the R'95 International Congress, Geneva, Switzerland.
- Haight, M. (2004). *Technical report: integrated solid waste management model*. School of Planning, University of Waterloo, Waterloo.
- Hajekova, E. and Bajus, M. (2005). Recycling of low-density polyethylene and polypropylene via copyrolysis of polyalkene oil/waxes with naphtha: product distribution and coke formation. *J Anal Pyrolysis* **74**, 270–281.
- Halle, R.W. (1994). Environmentally friendly films made with a new family of linear ethylene polymers. *J Plastic Films Sheeting* **10**(1), 65–77.
- Hamann, B., Hólsenberg, D. and Leutbecher, T. (1995). The use of recycled image tube glass for the fabrication of glass fibres. In *Recovery, recycling and reintegration*, Collected Papers of the R'95 International Congress, Geneva, Switzerland.

- Hamelers, H.V.M. (1994). Composting plant design. In *Waste management and recycling international* (M.A. Johnson, ed.), pp. 51–55. Sterling Publications Limited, London.
- Hanna, G.A. (1994). Designing for responsible disposal. In *Waste management and recycling international* (M.A. Johnson, ed.), pp. 59–61. Sterling Publications Limited, London.
- Harmati, Z., Moser, E.M., Boll, P.O. and Lang, F.R. (1995). How effective does an unused pet-barrier layer protect food against contamination by recycled pet materials. A preliminary study on diffusion of model substances in PET-plastics. In *Recovery, Recycling, and Reintegration*, Collected Papers of the R'95 International Congress, Geneva, Switzerland.
- Hasegawa, M., Isogai, A., Kuga, S. and Onabe, F. (1994). Preparation of cellulose-chitosan blend film using chloral/dimethylformamide. *Polymer* **35**, 983–987.
- Hasegawa, M., Isogai, A., Onabe, F. and Usuda, M. (1992a). Dissolving states of cellulose and chitosan in trifluoroacetic acid. *J Appl Polym Sci* **45**, 1857–1863.
- Hasegawa, M., Isogai, A., Onabe, F., Usuda, M. and Atalla, R.J. (1992b). Characterization of cellulose-chitosan blend films. *J Appl Polym Sci* **45**, 1873–1879.
- Hearn, G.L. (2003). Plastics identification for recycling (Shanks First Fund). Wolfson Electrostatics report 304B/GLH for EB Nationwide.
- Hearn, G.L. and Ballard, J.R. (2005). The use of electrostatic techniques for the identification and sorting of waste packaging materials. *Resources Conservat Recyc* **44**, 91–98.
- Hermesmeyer, D., Diekmann, R., Van der Ploef, R.R. and Horton, R. (2002). Physical properties of a soil substitute derived from an aluminium recycling by-product. *J Hazard Mater* **B95**, 107–124.
- Hertzog, R. (1995). PET–recycling Switzerland: economic efficiency of a business-led recycling network. In *Recovery, Recycling, and Reintegration*, Collected Papers of the R'95 International Congress, Geneva, Switzerland.
- Hope, P.S., Parsons, D.A.G., Capacio, G. and Kitchiner, M.J. (1992). The issue of contamination in Europe. *Makromol Chem Macromol Symp* **57**, 383–395.
- Huang, S.J. (1985). Biodegradable polymers. In *Encyclopedia of polymer science and engineering*, Vol. 2 (A. Klingsberg, J. Muldoon and A. Salvatore, eds), pp. 220–243. Wiley, New York.
- Hull, J.B., Langton, C.M. and Jones, A.R. (1994). An ultrasonic method for identifying polymeric materials/components for reclamation and recycling. *Macromolec Rep* **A31**(687), 1191–1199.
- Hynes, M.J. and Jonson, B. (1997). Lead, glass, and the environment. *Chem Soc Rev*. pp. 133–146.
- IPCC (International Panel on Climate Change). (1996). Revised 1996 IPCC Guidelines for national greenhouse gas inventories: workbook. International Panel of Climate Change.
- IPPC (2000). Integrated pollution prevention and control. Best available techniques reference document on the production of iron and steel. IPPC Bureau, Seville.
- Ishikura, S. (1993). Chitin and chitosan. *Gekkan Fudo Kemikaru* **9**, 62–64.
- Jenkins, W.A. (1991). *Packaging foods with plastics*, pp. 291–297. Technomic Publishing Company, Inc., Lancaster.

- Kaiser, J.P., Neff, A. and Raschle, P. (1995). Biological transformation (composting) of organic materials. In *Recovery, Recycling, and Reintegration*, Collected Papers of the R'95 International Congress, Geneva, Switzerland.
- Kaiser, M. (1995). Eco-efficiency: a possible way towards a generally applicable scale based LCA model. In *Recovery, Recycling, and Reintegration*, Collected Papers of the R'95 International Congress, Geneva, Switzerland.
- Kaminsky, W. (1995). Pyrolysis with respect to recycling of polymer. *Angewandte Makromolek Chem* **232**(4137), 151–165.
- Kaminsky, W., Predel, M. and Sadiki, A. (2004). Feedstock recycling of polymers by pyrolysis in a fluidised bed. *Polym Degradat Stabil* **85**, 1045–1050.
- Kanat, G., Demir, A., Ozkaya, B. and Sinan Bilgili, M. (2006). Addressing the operational problems in a composting and recycling plant. *Waste Manage* **26**, 1384–1391.
- Kannah, K. (1995). Special waste disposal and duty of care during a furnace demolition. *Glass Technol* **36**(1), 5–8.
- Karakasidis, N.G. (1997). Recovery raw materials and energy from aseptic paperboards. *Food Drinks* **2**, 58–62.
- Kehayoglou, A.H. and Arvanitoyannis, I. (1990). Octane/dodecane lactam polyamides (nylon 8/12). *Eur Polym J* **26**, 261–268.
- Kenny, G.R. (1995). Automated plastic bottle separation case studies – new developments & recycling overview. In *Recovery, Recycling, and Reintegration*, Collected Papers of the R'95 International Congress, Geneva, Switzerland.
- Kester, J.J. and Fennema, O. (1986). Edible films and coatings: a review. *Food Technol* **40**, 47–59.
- Khoei, A.R., Masters, I. and Gethin, D.T. (2002). Design optimization of aluminium recycling using Taguchi technique. *J Mater Process Technol* **127**, 96–106.
- Kim, S.H., Han, Y.K., Ahn, K.D., Kim, Y.H. and Chang, T. (1993). Preparation of starshaped polylactide with pentaerythritol and stannous octoate. *Makromol Chem* **194**, 3229–3236.
- Kim, S.H., Han, Y.K., Kim, Y.H. and Hong, S.I. (1992). Multifunctional initiation of lactide polymerization by stannous octoate/pentaerythritol. *Makromol Chem* **193**, 1623–1631.
- Kinsella, J.E. (1984). Milk proteins: physicochemical and functional properties. *CRC Crit Rev Food Sci Nutr* **21**, 197–262.
- Kiyotsukuri, T., Nagata, M., Kitazawa, T. and Tsutsumi, N. (1992). Synthesis of polymers from α -amino acids by polyaddition. *Eur Polym J* **28**, 183–186.
- Kobayashi, H., Hyon, S.H. and Ikada, Y. (1991). Water-curable and biodegradable prepolymers. *J Biomed Mater Res* **25**, 1481–1494.
- Kok, R., Benders, R.M.J. and Moll, H.C. (2006). Measuring the environmental load of household consumption using some methods based on input-output energy analysis: a comparison of methods and a discussion of results. *Energy Pol* **34**, 2744–2761.
- Kortekaas, S., Vidal, G., Yan-Ling, H., Lettinga, G. and Field, J.A. (1998). Anaerobic–aerobic treatment of toxic pulping black liquor with upfront effluent recirculation. *J Ferment Bioeng* **86**, 97–110.
- Krauss, M., Sebastian, K. and Kappel, J. (1995). The recycling of filter dust in the German container glass industry. *Recovery, recycling and reintegration*, Collected Papers of the R'95 International Congress, Geneva, Switzerland.

- Kricheldorf, H.R., Berl, M. and Scharnagl, N. (1988). Poly(lactones). 9. Polymerization mechanism of metal alkoxide. Initiated polymerizations of lactide and various lactones. *Macromolecules* **21**, 286–293.
- Krishna, S.P., Satyanarayana, D. and Mohan, R.D.V. (1998). *J Appl Polymer Sci* **70**, 2251.
- Krivtsov, V, Wager, P.A., Dacombe, P. *et al.* (2004). Analysis of energy footprints associated with recycling of glass and plastic – case studies for industrial ecology. *Ecol Model* **174**, 175–189.
- Krochta, J.M., Baldwin, E.A. and Nisperos-Carriedo, M.O. (1994). *Edible coatings and films to improve food quality*. Technomic, Lancaster.
- Krochta, J.M. and De Mulder-Johnston, C. (1997). Edible and biodegradable polymer films: challenges and opportunities. *Food Technol* **51**(2), 61–74.
- Krupp, L.R. and Jewell, W. (1992). Biodegradability of modified plastic films in controlled biological environments, *Environ Sci Technol* **26**, 193–198.
- Kumar, S.G. (1987). *Biodegradable polymers: prospects and progress*. Marcel Dekker, New York.
- Lamber, R., Deventura, W. and Conrad, C. (1995). *Recovery, Recycling, and Reintegration*, Collected Papers of the R'95 International Congress, Geneva, Switzerland.
- Lambert, C.P. (1995). Identification and separation of plastics in mixed waste. In *Recovery, Recycling, and Reintegration*, Collected Papers of the R'95 International Congress, Geneva, Switzerland.
- Lawton, J.W. and Fanta, C.F. (1994). Glycerol plasticized films prepared from starch-poly(vinylalcohol) mixtures: effect on poly(ethylene *co*-acrylic acid). *Carbohydr Polym* **23**, 275–280.
- Lazzaro, G. and Atzori, C. (1992). Recycling of aluminium trimmings by conform process. *Light Met* 1379.
- Lee, Y.M., Kim, S.H. and Kim, S.J. (1996). Preparation and characteristics of b-chitin and poly(vinylalcohol) blend. *Polymer* **37**, 5897–5905.
- Leenslag, J.W., Gogolewski, S. and Pennings, A. (1984). Resorbable materials of poly(L-lactide). V. Influence of secondary structure on the mechanical properties and hydrolyzability of poly(L-lactide) fibres produced by a dry spinning method. *J Appl Polym Sci* **29**, 2829–2842.
- Lemann, M. (1995). Waste handling – the solution of the waste disposal department of the City of Zurich. In *Recovery, Recycling, and Reintegration*, Collected Papers of the R'95 International Congress, Geneva, Switzerland.
- Lentz, H. and Mormann, W. (1992). Chemical recycling of polyurethanes and separation of the components by supercritical ammonia. *Makromol Chem Macromol Symp* **57**, 305–310.
- Lenz, R.W. (1993). Biodegradable polymers. In *Biopolymers* (R. Langer and N. Peppas, eds), pp. 1–40. Springer-Verlag, Berlin.
- Li, S.M., Garreau, H. and Vert, M. (1990a). Structure-property relationships in the case of the degradation of massive aliphatic poly-(α -hydroxy acids) in aqueous media, Part 1: Poly (DL-lactic acid). *J Mater Sci Mater Med* **1**, 123–130.
- Li, S.M., Garreau, H. and Vert, M. (1990b). Structure-property relationships in the case of the degradation of massive aliphatic poly-(α -hydroxy acids) in aqueous media, Part 2: Degradation of lactideglycolide copolymers: PLA37.5GA25 and PLA75/GA25. *J Mater Sci Mater Med* **1**, 131–137.

- Li, S.M., Garreau, H. and Vert, M. (1990c). Structure-property relationships in the case of the degradation of massive aliphatic poly-(α -hydroxy acids) in aqueous media, Part 3. Influence of the morphology of poly(L-lactic acid). *J Mater Sci Mater Med* **1**, 198–203.
- Li, X.D., Poon, C.S., Lee, S.C., Chung, S.S. and Luk, F. (2003). Waste reduction and recycling strategies for the in-flight services in the airline industry. *Resources Conservat Recyc* **37**, 87–99.
- Liesemer, R. (1992). A perspective of the plastics waste issue in the United States. *Makromol Chem Macromol Symp* **57**, 1–13.
- Logozar, K., Radonjic, G. and Bastic, M. (2006). Incorporation of reverse logistics model into in-plant recycling process: a case of aluminium industry. *Resources Conservat Recyc* **49**, 49–67.
- Lott Fischer, J., Beffa, T., Blanc, M., Lyon, P.F. and Aragno, M. (1995). Development of *Aspergillus fumigatus* during composting of organic wastes. In *Recovery, Recycling, and Reintegration*, Collected Papers of the R'95 International Congress, Geneva, Switzerland.
- Lourdin, D., Della Valle, G. and Colonna, P. (1995). Influence of amylose content on starch films and foams. *Carbohydr Polym* **27**, 261–270.
- Lunkwitz, K., Lappan, U. and Lehmann, D. (2000). Modification of fluoropolymers by means of electron beam irradiation. *Radiat Phys Chem* **57**, 373–376.
- Lusinchi, J.M., Pietrasanta, Y., Robin, J.J. and Boutevin, B. (1998). Recycling of PET and PVC wastes. *J Appl Polymer Sci* **69**, 657–665.
- Mader, F.W. (1992). Plastics waste management in Europe. *Makromol Chem Macromol Symp* **57**, 15–31.
- Mancini, S.D., Remedio, M.V.P. and Zanin, M. (2000). Municipal plastic waste composition. *Saneamento Ambiental* **9**(67), 34–38 (in Portuguese).
- Marechal, J.Ch., Quillerou, J., Martin, C., Tersou, G., Hubert, F. and Durand, G. (1995). Insulation materials from flexible polyurethane foam wastes and polyols of polyethylene terephthalate glycolysis. In *Recovery, Recycling, and Reintegration*, Collected Papers of the R'95 International Congress, Geneva, Switzerland.
- Marias, F., Roustan, H. and Pichat, A. (2005). Modelling of a rotary kiln for the pyrolysis of aluminium waste. *Chem Engine Sci* **60**, 4609–4622.
- Marilley, L., Beffa, T., Lott Fischer, J., Blanc, M. and Aragno, M. (1995). Biodiversity of mesophilic bacteria isolated from maturing compost. In *Recovery, Recycling, and Reintegration*, Collected Papers of the R'95 International Congress, Geneva, Switzerland.
- Mark, F.E. (1995). Energy recovery through co-combustion of mixed waste plastics and municipal solid waste. In *Recovery, Recycling, and Reintegration*, Collected Papers of the R'95 International Congress, Geneva, Switzerland.
- Masters, G.M. (1998). *Introduction to environmental engineering and science*, 2nd edn. Prentice-Hall International, Inc.
- Matusevich, Y.I. and Krul, L.P. (1999). *High Energy Chem* **33**, 72.
- Matusevich, Y.I., Polikarpov, A. and Krul, L.P. (1999). *High Energy Chem* **33**, 224.
- Melo, M.T. (1999). Statistical analysis of metal scrap generation: the case of aluminium in Germany. *Resources Conservat Recyc* **26**, 91–113.

- Mertzani, B. (1997). New Trends in Modern Ecological Packaging. *Food Drinks* **5**, 192–205.
- Michaeli, W. and Lackner, U. (1995). Degradative extrusion as a pretreating process for chemical recycling of plastics waste. *Angewandte Makromolek Chem* **232**(4138), 167–185.
- Michaels, A.S. and Bixler, H.J. (1961). Flow of gases through polyethylene. *J Polym Sci* **50**, 413–439.
- Mikos, A.G., Bao, Y., Cima, L.G., Ingber, D.E., Vacanti, J.P. and Langer, R. (1993). Preparation of poly(glycolic acid) bonded fibre structures for cell attachment and transplantation. *J Biomed Mater* **27**, 183–189.
- Miltz, J., Ram, A. and Nir, M.M. (1997). Prospects for application of post consumer used plastics in food packaging. *Food Addit Contam* **14**(6&7), 649–659.
- Miner, R. and Unwin, J. (1991). Progress in reducing water use and wastewater loads in the US paper industry. *Tappi* **74**(8), 127.
- Miyamoto, Y. (2003). Ecomaterials synthesis and recycling by nitriding combustion. *Curr Opin Solid State Mater Sci* **7**, 241–245.
- Molgaard, C. (1995). Environmental impacts by disposal of plastic from municipal solid waste. *Resources Conservat Recyc* **15**, 51–63.
- Molgaard, C. and Alting, L. (1995). Environmental impacts by disposal processes. In *Recovery, Recycling, and Reintegration*, Collected Papers of the R'95 International Congress, Geneva, Switzerland.
- Mondorf, U. and Jensen, F. (1995). Reuse of packages, recycling of packaging materials and disposal of used packages. *Bulletin of IDF* **300**, Chapter 13, pp. 78–83.
- Morris, J.R., Phillips, P.S. and Read, A.D. (1998). The UK landfill tax: an analysis of its contribution to sustainable waste management. *Resources Conservat Recycl* **23**, 259–270.
- Moser, E.V. and Dudler, V. (1995). Identification and transport of substances in recycled PET-bottles. In *Recovery, Recycling, and Reintegration*, Collected Papers of the R'95 International Congress, Geneva, Switzerland.
- Muzzarelli, R.A.A. (1977). *Chitin*. Pergamon Press, Oxford.
- Muzzarelli, R.A.A. (1996). Chitosan-based dietary foods. *Carbohydr Polym* **29**, 309–316.
- Nag, J. and Jarausch, M. (1995). Processing of lead containing waste water in the glass industry. In *Recovery, Recycling, and Reintegration*, Collected Papers of the R'95 International Congress, Geneva, Switzerland.
- Nakayama, A., Kawasaki, N., Arvanitoyannis, I. and Yamamoto, N. (1995). Enzymatic hydrolysis of poly(L-lactide-co-e-caprolactone)s. *Sen-I-Gakkaishi* **51**, 131–136.
- Nakayama, A., Kawasaki, N., Arvanitoyannis, I. and Yamamoto, N. (1995). Synthesis and degradability of a novel aliphatic polyester. *Polymer* **36**, 1295–1301.
- Nakayama, A., Kawasaki, N., Arvanitoyannis, I. and Yamamoto, N. (1993). Biodegradability of poly(L/DL-Lactide-co-DL-b-Methyl-d-Valerolactone). In *Proceedings of the Third International Workshop of Biodegradable Polymers* (Y. Doi and K. Fukuda, eds), pp. 557–561. Elsevier, Amsterdam.
- Narayan, R. (1991). Starch based plastics. In *Polymers from biobased materials* (H.L. Chum, ed.), pp. 90–114. Noyes Data, New Jersey.
- Narayan, R. and Snook, J. (1994). The role of biodegradable materials in solid waste management. *Waste Management and Recycling International*, pp. 40–43. Sterling, London.

- National Solid Waste Management Association (NSWA). (1990). Recycling in the States, Special Report.
- Neumann, U. (1995). Biogas from organic waste. In *Recovery, Recycling, and Reintegration*, Collected Papers of the R'95 International Congress, Geneva, Switzerland.
- Nguyen, T., Daester, H. and Mensy, J-P. (1995). Glass recycling from treatment detoxification of special post-consumer waste. *Recovery, Recycling, and Reintegration*, Collected Papers of the R'95 International Congress, Geneva, Switzerland.
- Nijkerk, A.A. (1995). Wealth in garbage: Recycling, past, present and future. *Recycling and cleaner production*, pp. 145–156. International Organization of Biopolitics, BIO, Athens.
- Nishida, H. and Tokiwa, Y. (1993a). Effects of higher-order structure of poly(3-hydroxybutyrate) on its biodegradation. II. Effects of crystal structure on microbial degradation. *Environ Polym Degrad* **1**, 65–80.
- Nishida, H. and Tokiwa, Y. (1993b). Distribution of poly(b-hydroxybutyrate) and poly(ϵ -caprolactone) aerobic degrading microorganisms in different environments. *Environ Polym Degrad* **1**, 227–233.
- Nishida, H. and Tokiwa, Y. (1992). Effects of higher-order structure of poly(3-hydroxybutyrate) on its biodegradation. I. Effects of heat treatment on microbial degradation. *J Appl Polym Sci* **46**, 1467–1476.
- Noguchi, T., Miyoshita, M., Inagaki, Y. and Watanabe, H. (1998a). A new recycling system for expanded polystyrene using a natural solvent. Part 1. A new recycling technique. *Packaging Technol Sci* **11**, 19–27.
- Noguchi, T., Inagaki, Y., Miyoshita, M. and Watanabe, H. (1998b). A new recycling system for expanded polystyrene using a natural solvent. Part 2. Development of a prototype production system. *Packaging Technol Sci* **11**, 29–37.
- Noguchi, T., Tomita, H., Satake, K. and Watanabe, H. (1998c). A new recycling system for expanded polystyrene using a natural solvent. Part 3. Life cycle assessment. *Packaging Technol Sci* **11**, 39–44.
- OECD. (1987). *Household waste: separation, collecting and recycling*. OECD Publications.
- Okawa, A. (1995). The forecast of mechanical recycling and energy recovery from plastics in MSW (in Japan). In *Recovery, Recycling, and Reintegration*, Collected Papers of the R'95 International Congress, Geneva, Switzerland.
- Okuda, H. (1995). Blood pressure control and role of chitosan, *Gekkan Fudo Kemikaru* **11**, 33–38.
- Onusseit, H. (2006). The influence of adhesives on recycling. *Resources Conservat Recyc* **46**, 168–181.
- Otey, F.H., Mark, A.M., Mehlretter, C.L. and Russell, C.R. (1974). Starch-based film for degradable agricultural mulch. *Indust Engine Chem Prod Res Dev* **13**(1), 90–92.
- Paine, F.A. and Paine, H.Y. (1992). *A handbook of food packaging*, pp. 1–52. Blackie Academic Professional, London.
- Palin, R. and Whiting, K. (1998). All fired up. *Chem Ind*, 928–931.
- Pappa, G., Boukouvalas, C., Giannaris, C. *et al.* (2001). The selective dissolution/precipitation technique for polymer recycling: a pilot unit application. *Resources Conservat Recyc* **34**, 33–44.

- Park, H.J., Chinnan, M.S. and Shewfelt, R.L. (1994). Edible coating effects on storage life and quality of tomatoes. *J Food Sci* **59**, 568–570.
- Park, H.J., Testin, R.F., Park, H.J., Vergano, P.J. and Weller, C.L. (1994). Fatty acid concentration effect on tensile strength, elongation, and water vapor permeability of laminated edible films. *J Food Sci* **59**, 916–919.
- Park, H.J., Weller, C.L., Vergano, P.J. and Testin, R.F. (1993). Permeability and mechanical properties of cellulose-based edible films. *J Food Sci* **58**, 1361–1364, 1370.
- Parker, G. (1991). Saving energy in packaging. *British Food J* **93**(3), 19–22.
- Pascoe, R.D. and O'Connell, B. (2003). Development of a method for separation of PVC and PET using flame treatment and flotation. *Min Engine* **16**, 1205–1212.
- Patel, M., Von Thienen, N., Jochem, E. and Worrell, E. (2000). Recycling of plastics in Germany. *Resources Conservat Recyc* **29**, 65–90.
- Paula, M.M.S., Rodrigues, F.B.B.M., Bernardin, A.M., Fiori, M.A. and Angioletto, E. (2005). Characterization of aluminized polyethylene blends via mechanical recycling. *Mater Sci Engin* **A403**, 37–41.
- Peanasky, J.S., Long, J.M. and Wool, R.P. (1991). Percolation effects in degradable polyethylene-starch blends. *Polym Sci Part B Polym Phys* **29**, 565–579.
- Pearce, F. (1997). Burn me. *New Scientist*, **156**(2019), 30–34.
- Pearson, W. (1996). Plastics. *The McGraw Hill Recycling Handbook*. McGraw Hill, New York.
- Peringer, P., Kradolfer, J.P., Koller, P. and Villegas, A. (1995). Biomethanation of organic, domestic sorted household wastes. In *Recovery, Recycling, and Reintegration*, Collected Papers of the R'95 International Congress, Geneva, Switzerland.
- Perou, A.L., Laoubi, S. and Vergnaud, J.M. (1999). Model for transfer of contaminant during the coextrusion of three layer food package with a recycled polymer. Effect on the time of protection of the food of the relative thickness of the layers. *J Appl Polym Sci* **73**, 1939–1948.
- Pinetti, L. (1995). Plastics recycling opportunities: a leam in Europe. *Recycling and Cleaner Production*, Int. Org. Biopolitic, 38–81.
- Pitt, G.G., Chasalow, F.J., Hibionada, Y.M., Klimas, D.M. and Schindler, A. (1981). Aliphatic polyesters. I. The degradation of poly(e-caprolactone) in vivo. *J Appl Polym Sci* **26**, 3779–3787.
- Plinke, E. and Kaempf, K. (1995). Ecological, economical and technical limits to recycling of packaging materials. In *Recovery, Recycling, and Reintegration*, Collected Papers of the R'95 International Congress, Geneva, Switzerland.
- Poulakis, J.G. and Papaspyrides, C.D. (1995). The dissolution reprecipitation technique applied on high-density polyethylene. 1. Model recycling experiments. *Adv Polym Technol* **14**(3), 237.
- Psomiadou, E., Arvanitoyannis, I., Biliaderis, C., Ogawa, H. and Kawasaki, N. (1998). Biodegradable films made from low density polyethylene (LDPE), wheat starch and soluble starch for food packaging applications; Part 2. *Carbohydr Polym* **33**, 227–242.
- Quinkertz, R., Rombach, G. and Liebig, D. (2001). A scenario to optimise the energy demand of aluminium production depending on the recycling quota. *Resources Conservat Recyc* **33**, 217–234.

- Rabah, M.A. (2003). Preparation of aluminium-magnesium alloys and some valuable salts from used beverage cans. *Waste Manage* **23**, 173–182.
- Raschle, P., Baumann, U. and Kaiser, J.P. (1995). Biodeterioration, biogenous degradation and standards for microbiological materials testing. In *Recovery, Recycling, and Reintegration*, Collected Papers of the R'95 International Congress, Geneva, Switzerland.
- Rathke, T.D. and Hudson, S.M. (1994). Review of chitin and chitosan as fibre and film formers. *J Macromol Sci Rev Macromol Chem Phys* **C34**, 375–437.
- Read, A.D. (1999a). A weekly doorstep recycling collection, I had no idea we could. Overcoming the local barriers to participation. *Resources Conservat Recycl* **26**, 217–249.
- Read, A.D. (1999b). Making waste work: making UK national solid waste strategy work at the local scale. *Resources Conservat Recycl* **26**, 259–285.
- Read, A.D., Phillips, P.S. and Murphy, A. (1997). English county councils and their agenda for waste minimization. *Resources Conservat Recycl* **20**, 277–294.
- Redepenning, K.H. (1995). Waste to energy with the VTA pyrolysis and gasification processes. In *Recovery, Recycling, and Reintegration*, Collected Papers of the R'95 International Congress, Geneva, Switzerland.
- Reeve, M.S., McCarthy, S.P., Downey, M.J. and Goss, R.A. (1994). Polylactide stereochemistry: effect of enzymatic degradability. *Macromolecules* **27**, 825–831.
- Reifsnider, K.L. (1994). Micromechanical modelling of composites. *Polymer* **35**, 5035–5040.
- Renkow, M. and Rubin, A.R. (1998). Does municipal solid waste composting make economic sense? *J Environ Manage* **53**, 339–347.
- Rentz, O., Hahre, S., Jochum, R. *et al.* (1999). Exemplary investigation into the state of practical realisation of integrated environmental protection within the metal industry and development of general requirements. Final report on Behalf of the German Federal Environmental Agency (Report no. UBA-FB 50 462/1). Karlsruhe: French-German Institute for Environmental Research.
- Rentz, O., Schmittinger, A., Jochum, R. and Schultmann, F. (2001). Exemplary investigation into the state of practical realisation of integrated environmental protection within the ceramics industry under observance of the IPPC-Directive and the development of BAT reference documents. Final report on Behalf of the German Federal Environmental Agency (Research project no. 298 94 313/07). Karlsruhe: French-German Institute for Environmental Research.
- Revyakin, O., Zicans, J., Kalnins, M. and Kalkis, V. (1999). Properties of composites based on post-consumer poly(ethylene terephthalate) and polypropylene. *Polym Recycl* **4**, 33–40.
- Riess, R. (1995). Recycling of engineering plastics – options and limitations. In *Recovery, Recycling, and Reintegration*, Collected Papers of the R'95 International Congress, Geneva, Switzerland.
- Rijkema, L.P.M. (1995). Municipal solid waste combustion flow and cost expert model. In *Recovery, Recycling, and Reintegration*, Collected Papers of the R'95 International Congress, Geneva, Switzerland.
- Robertson, G.L. (1993). *Food packaging: principles and practice*, pp. 99–101. Marcel Dekker, New York.

- Ross, S. and Evans, S. (2003). The environmental effect of reusing and recycling a plastic-based packaging system. *J Cleaner Product* **11**, 561–571.
- Saetti, G.F. and Peroni, A. (1995). Collection, recovery and reuse of food and non-food plastic bottles. In *Recovery, Recycling, and Reintegration*, Collected Papers of the R'95 International Congress, Geneva, Switzerland.
- Samuel, M. (2003). A new technique for recycling aluminium scrap. *J Mater Process Technol* **135**, 117–124.
- Sanko, G. (1999). Cleaning during the recycling process. *Recyc Prod News*, **7**(6), 3.
- Santos, A.S.F., Teixeira, B.A.N., Agnelli, J.A.M. and Manrich, S. (2005). Characterization of effluents through a typical plastic recycling process: an evaluation of cleaning performance and environmental pollution. *Resources Conservat Recyc* **45**, 159–171.
- Satyanarayana, D. and Chaterji, P.R. (1993). Biodegradable polymers: challenges and strategies. *J Macromol Sci Rev Macromol Chem Phys* **33**, 349–368.
- Schaeffer, H.A. (1996). Recycling of cullet and filter dust in German glass industry. *Glastech Ber Glass Sci Technol* **69**(4), 101–106.
- Schaub, S.M. and Leonard, J.J. (1996). Composting: an alternative waste management option for food processing industries. *Trends Food Sci Technol* **7**, 263–268.
- Schnabel, W. (1981). *Polymer degradation: principles and practical applications*, pp. 154–177. Hanser, Munich.
- Schnabel, W., Levchik, G.F., Wilkie, C.A., Jiang, D.D. and Levchik, S.V. (1999). Thermal degradation of Polystyrene, poly(1,4-butadiene) and copolymers of styrene and 1,4-butadiene irradiated under air or argon with 60-Co-gamma-rays. *Polym Degrad Stabil* **63**, 365–375.
- Schudel, D. and Koller, W. (1995). Economic solutions to materials recycling of plastics using the Buhler NIR spectrometer NIRIKS. In *Recovery, Recycling, and Reintegration*, Collected Papers of the R'95 International Congress, Geneva, Switzerland.
- Schultmann, F., Engels, B. and Rentz, O. (2004). Flowsheeting-based simulation of recycling concepts in the metal industry. *J Cleaner Product* **12**, 737–751.
- Scott, G. and Gilead, D. (1995). Degradable polymers in waste and litter control. In *Degradable polymers: principles and applications* (G. Scott and D. Gilead, eds), pp. 247–258. Chapman and Hall, London.
- Seddon-Brown, W. (1995). Energy recovery-adding value to waste. In *Recovery, Recycling, and Reintegration*, Collected Papers of the R'95 International Congress, Geneva, Switzerland.
- Serrano, D.P., Aguado, J., Escola, J.M. *et al.* (2004). Feedstock recycling of agriculture plastic film wastes by catalytic cracking. *Appl Catal B Environ* **49**, 257–265.
- Seyfarth, H.E., Riedel, B., Mensel, E., Muller, W. and Taeger, E. (1995). Chemical dissociation of amide-bonds—recycling of pure polymer wastes. In *Recovery, Recycling, and Reintegration*, Collected Papers of the R'95 International Congress, Geneva, Switzerland.
- Shen, H., Forsberg, E. and Pugh, R.J. (2001). Selective flotation separation of plastics by particle control. *Resources Conservat Recyc* **33**, 37–50.
- Shen, H., Pugh, R.J. and Forsberg, E. (2002). Floatability, selectivity and flotation separation of plastics by using a surfactant. *Colloids Surfaces A Physicochem Engine Aspects* **196**, 63–70.

- Shiaw, D., Hu, G. and Liu, H.J. (1994). Effects of soft segments and hydrolysis on the crystallization behavior of degradable poly(oxyethylene)/poly(L-lactide) block copolymers. *Macromol Chem Phys* **195**, 1213–1223.
- Shinzato, M.C. and Hypolito, R. (2005). Solid waste from aluminum recycling process: characterization and reuse of its economically valuable constituents. *Waste Manage* **25**, 37–46.
- Shogen, R.L. (1993). Complexes of starch with telechelic poly(ϵ -caprolactone) phosphate. *Carbohydr Polym* **22**, 93–98.
- Siegenthaler, E. (1995). KOMPOGAS – a novel process for obtaining energy and high-quality compost soil from biogenic domestic and commercial waste. In *Recovery, Recycling, and Reintegration*, Collected Papers of the R'95 International Congress, Geneva, Switzerland.
- Sierra-Alvarez, R. (1990). The role of natural wood constituents on the anaerobic treatability of forest industry wastewaters. Doctoral thesis. Wageningen, Netherlands.
- Sillekens, W.H., Sano, T., Terasaki, M., Matsuno, K. and Kals, J.A.G. (1997). Formability of recycled aluminium alloy 5017. *J Mater Process Technol* **65**, 252–260.
- Simons, B.P., Desmet, F. and van der Goep, L.A. (1995). The recycling of household plastic waste. In *Recovery, Recycling, and Reintegration*, Collected Papers of the R'95 International Congress, Geneva, Switzerland.
- Smith, D.N., Harrison, L.M. and Simmons, A.J. (1999). A survey of schemes in the United Kingdom collecting plastic bottles for recycling. *Resources Conservat Recyc* **25**, 17–34.
- Sohair, I.A.E., Nasr, F.A., Ibrahim, H.S., Badr, N.M. and Askalany, A.R.M. (2006). Pollution prevention pays off in a board paper mill. *J Cleaner Product*, 1–5 (in press).
- Soler, T.Q. (1992). Identification and segregation of materials in mixed waste. *Makromol Chem Macromol Symp* **57**, 123–131.
- Spadaro, G., Acierno, D., Calderaro, E. and Valenza, A. (1992). Structural induced modifications in blends of polyamide with gamma irradiated low density polyethylene. *Radiat Phys Chem* **40**, 249–254.
- Spadaro, G., Acierno, D., Dispenza, C., Calderaro, E. and Valenza, A. (1996). Physical and structural characterization of blends made with polyamide 6 and polyethylenes. *Radiat Phys Chem* **48**, 207–216.
- Spadaro, G., Valenza, A., Calderaro, E. and Brucato, V. (1993). Molecular modifications and crystallization relationships for gamma-irradiated LLDPE/PA6 blends. *Thermochim Acta* **227**, 75–82.
- Spengler, T., Geldermann, J., Hahre, S., Sieverdingbeck, A. and Rentz, O. (1998) Development of a multiple criteria based decision support system for environmental assessment of recycling measures in the iron and steel making industry. *J Cleaner Product* **6**, 37–52.
- Stahel, W.R. (1995). The service economy: a cultural and organizational change. In *Recovery, Recycling, and Reintegration*, Collected Papers of the R'95 International Congress, Geneva, Switzerland.
- Stauffer, D. (1985). *Introduction to percolation theory*. Taylor and Francis, London.
- Steiner, R. (1995). The water cooled NOELI gate for municipal solid waste incineration. In *Recovery, Recycling, and Reintegration*, Collected Papers of the R'95 International Congress, Geneva, Switzerland.

- Stojmirovic, A., Kadota, K. and Chudnovsky, A. (1992). An equilibrium process zone in polymeric materials. *J Appl Polym Sci* **46**, 1051–1056.
- Storey, R.F. and Shoemaker, K.A. (1993). Poly(glycolic acid) fibre-reinforced bio-absorbable composites with interfacial properties. *Polym Bull* **31**, 331–338.
- Stotzel, E. (1997). Cullet for flat glass. *Glass Technol* **38**(6), 185–188.
- Tamaddon, F., Bengtsson, L. and Hogland, W. (1995). Storage of municipal waste-fuel and related problems. In *Recovery, Recycling, and Reintegration*, Collected Papers of the R'95 International Congress, Geneva, Switzerland.
- Teh, J.W., Rudin, A., Yuen, S.Y., Hung, J.C. and Pank, D.M. (1994). LLDPE/PP blends in tubular film extraction: recycling of mixed films. *J Plastic Films Sheeting* **10**(10), 288–301.
- Tenorio, J.A.S. and Espinosa, D.C.R. (2002). Effect of salt/oxide interaction on the process of aluminum recycling. *J Light Metals* **2**, 89–93.
- Thurgood, M. (1995). Recycling as part of complete waste management strategy. *Recycling and Cleaner Production*, pp. 38–81. Int. Org. Biopolitics.
- Tokiwa, Y., Iwanoto, A., Kajama, M., Kataoka, N. and Nishida, H. (1989). *Macromol Chem Macromol Symp* **57**, 273.
- Tokiwa, Y., Suzuki, T. and Takeda, K. (1988). Two types of lipases in hydrolysis of polyester. *Agricult Biol Chem* **52**, 1937–1943.
- Tokiwa, Y., Suzuki, T. and Takeda, K. (1983). Hydrolysis of polyesters by *Rhizopus arrhizus* lipase. *Agricult Biol Chem* **50**, 1323–1325.
- Trauberg, E. (1995). *Recovery, Recycling, and Reintegration*, Collected Papers of the R'95 International Congress, Geneva, Switzerland.
- Tsimilis, K.C. and Hadjimanolis, A. (1995). Recycling and recovery activities in small developing countries – the Cyprus experience. In *Recovery, Recycling, and Reintegration*, Collected Papers of the R'95 International Congress, Geneva, Switzerland.
- Ulgianti, S., Bargigli, S. and Raugei, M. (2006). An energy evaluation of complexity, information and technology, towards maximum power and zero emissions. *J Cleaner Product*, 1–14.
- Valenza, A., Spadaro, G. and Acierno, D. (1992). Blends of nylon 6 and LDPE functionalized by gamma radiation: processing characteristics and mechanical properties. *Proceedings of the Antec '92, Plastics: Shaping the Future*, **2**, pp. 1895–1898. Society of Plastics Engineering, Detroit.
- Van Gisbergen, J.G.M., Meijer, H.E.H. and Lemstra, P.J. (1989). Structured polymer blends 2. Processing of polypropylene/EPDM blends: controlled rheology and morphology fixation via electron beam. *Polymer* **30**, 2153–2157.
- Van Krevelen, D.W. (1990). *Properties of polymers*, 3rd edn, pp. 189–225. Elsevier, Amsterdam.
- Van Rijwijk, H.C. (1995). A bottom up model for integrated life cycle management. In *Recovery, Recycling, and Reintegration*, Collected Papers of the R'95 International Congress, Geneva, Switzerland.
- Vert, M., Li, S.M., Spenlehauer, G. and Guerin, P. (1992). Bioresorbability and biocompatibility of aliphatic polyesters. *J Mater Sci Mater Med* **3**, 432–446.

- Vidal, G., Videla, S. and Diez, M.C. (2001). Molecular weight distribution of *Pinus radayta* kraft mill wastewater treated by anaerobic digestion. *Bioresource Technol* **77**, 183–191.
- Vogas, P. (1995). Organization, management, marketing & communication in a complete system of reuse and recycling of materials. *Recyc Cleaner Product*, pp. 38–81. Int. Org. Biopolitics.
- Von Schoenberg, A. (1995). Municipal solid waste management and recycling – Germanys' experience. *Recyc Cleaner Product*, 82–106.
- Vos, H. (1994). State of the art composting and anaerobic digestion in The Netherlands. In *Waste Management and Recycling International*, p. 56. Sterling Publications Limited, London.
- Wachter, E. and Seiler, N. (1995). High temperature process for the separation of hazardous waste into an elution-resistant glass product and concentrated heavy metal dust. *Recovery, Recycling, and Reintegration*, Collected Papers of the R'95 International Congress, Geneva, Switzerland.
- Waite, R. (1995). *Household waste recycling*. Earthsian Publications Limited, London.
- Wang, L.K. and Pereira, N.C. (1980). Handbook of environmental engineering. *Solid waste processing and resource recovery*, **2**. Humana Press, Totowa.
- Wanjek, H. (1995). Feedstock recycling of old plastic packaging by the BASF process. In *Recovery, Recycling, and Reintegration*, Collected Papers of the R'95 International Congress, Geneva, Switzerland.
- Wather-Mausuchat, A. (1995). *Recovery, Recycling, and Reintegration*, Collected Papers of the R'95 International Congress, Geneva, Switzerland.
- White, P., Franke, M. and Hindle, P. (1995). *Integated solid waste management: a lifecycle inventory*. Blackie Academic & Professional, London.
- Wong, D.W.S., Gastineau, F.A., Gegorski, F.S., Tillin, S.T. and Pavlath, A.E. (1992). Chitosan-lipid films: microstructure and surface energy. *J Agricult Food Chem* **40**, 540–544.
- Wool, R.P. (1995). The science and engineering of polymer composite degradation. In *Degradable polymers* (G. Scott and D. Gilead, eds.), pp. 207–215. Chapman and Hall, London.
- Wu, S. (1992). Secondary relaxation, brittle ductile transition temperature and chain structure. *J Appl Polym Sci* **46**, 619–624.
- Xiao, Y. and Reuter, M.A. (2002). Recycling of distributed aluminium turning scrap. *Min Engine* **15**, 963–970.
- Yang, J. (1998). Radiation recycling of butyl rubber waste. In *Environmental applications of ionizing radiation* (W.J. Cooper, R.D. Curry and K.E. O'Shea, eds), pp. 601–611. Wiley, New York.
- Yang, J. and Liu, W. (2000). Technological development of irradiation reclamation of butyl rubber wastes. Presented at IAEA Consultant's Meeting, Saclay, France, 19–21 September.
- Yang, J., Zhang, D., Hou, J., He, B. and Xiao, B. (2006). Preparation of glass-ceramics from red mud in the aluminium industries. *Ceramics Intl* (in press).
- Yang, J.Z., Wang, M. and Otterbrite, R.L. (1993). Synthesis of novel copolyamides based on a-amino acids. *J Mater Sci Pure Appl Chem* **A30**, 503–515.

- Yasuda, H. and Stannett, V. (1962). Permeation, solution and diffusion of water in some high polymers. *J Polym Sc*, **57**, 907–923.
- Yerushalmi, D. (1992). Aluminum dross recovery process. United States Patent: 5, 102, 453. Available from: <http://www.uspto.gov/>.
- Yoda, N. (1999). Corporate management in the age of global environmental awareness: a case study of PET-bottle recycling issues in Japan. *Polymer Int* **48**, 944–951.
- Young, E. and Gordon, J. (1991). Getting the credit: a guide for local authorities on planning for recycling. A Waste Watch Publication.
- Zhang, S. and Forssberg, E. (1997). Mechanical separation-oriented characterization of electronic scrap. *Resources Conservat Recyc* **21**, 247–269.
- Zhang, X., Wyss, U.P., Pichora, D. and Goosen, M.F.A. (1993). Biodegradable polymers for orthopedic applications: synthesis and processability of poly(L-lactide) and poly(lactide-co-ε-caprolactone). *J Mater Sci Pure Appl Chem* **A30**, 933–947.
- Zhao, W., Hasegawa, S., Fujita, J. *et al.* (1996). Effect of irradiation on pyrolysis of polypropylene in the presence of zeolites. *Polym Degrad Stab* **53**, 199–206.
- Zhou, B., Yang, Y., Reuter, M.A. and Boin, U.M.J. (2006). Modelling of aluminium scrap melting in a rotary furnace. *Min Engine* **19**, 299–308.
- Zikakis, J.P. (ed.). (1984). *Chitin, chitosan and related enzymes*. Academic, Orlando.

e-addresses

- <http://www.raymond.com/rates97htm>
- <http://www.epa.gov/epaoswer/non-hw/muncpl/factbook/internet/mswf>
- <http://www.britglass.co.uk/recycling/glassrec.html>
- <http://www.britglass.co.uk/recycling/stats97.html>
- <http://www.esp.co.uk/machanical.html>
- <http://www.environment97.org/text/reception/r/techPapers/Papers/g19htm>
- <http://www.polyrecycling.ch/english/kvs.htm>
- <http://www.grn.org>
- <http://www.apme.org/environment/htm/0.4.htm>
- <http://www.apme.org/environment/htm/sustainable.future.pdf>
- <http://www.thesite.org.uk>
- <http://www.world-aluminium.org/applications/index.html>
- <http://www.world-aluminium.org/applications/packaging/index.html>
- <http://container-recycling.org/aluminated/gaphs.htm>
- <http://europa.eu.int/lib/>
- <http://www.plasticsresource.com/s-plasticsresource/docs/1900/1874.pdf>

This page intentionally left blank

Index

- Abattoirs *see* Meat waste
- Acidification potential, 110
- Activated bleaching earth, 727
- Activated carbon, 375, 531–2, 533
- Activated sludge treatment, 659–60
- Adsorbents from wine waste, 439–44
- Adsorption of cereal waste, 637, 657, 688
- Adsorption gels, 576
- Aerated static pile composting, 360
- Aerobasidium pullulans*, 398, 399, 418, 443
- Aerobic digestion
 - advantages/disadvantages, 505–6
 - dairy waste, 804, 821
 - food waste, 346, 348, 349, 350, 393–5
 - meat waste, 775–8
 - olive oil waste, 484, 501
 - see also* Anaerobic digestion;
Biodegradation
- Agenda 21, 42, 159
- Agricultural industry
 - ISO 14000, 60–1
 - waste, 6–9, 10–12
- Air pollution
 - European legislation, 192–206
 - identification of, 194
 - industry, 205–6
 - motor vehicles, 199–205
 - US legislation, 296–7
 - and wind energy, 17
- Air Pollution Index, 28–9
 - determination of, 30
- Air quality, 194–9
- Air tabling, 1004–5
- Alcoholic beverages *see* Brewing; Wine waste; Winemaking
- Alginic acid, 576
- Allelopathy, 580
- Almond by-products
 - datch, 608
 - shell, 708–9, 731
- Alpechin, 518, 534, 535
- Alperujo, 510, 537, 540, 549
- Alternative energy sources, 16–18
 - fuel cells, 17–18
 - geothermal, 17–18
 - hydropower, 17–18
 - solar energy, 16
 - wind energy, 17
- Aluminum, 958–75
 - LCA studies, 122–3
 - matrix composite chips, 971
 - non-metallic product, 968–70
 - recycling, 958–75
 - RECAL Programme, 964
 - recycling by-product, 968
 - slag processing, 974
- Aluminum foil, 966
- Ammonia, 196
- Amygdalin, 588
- Anaerobic digestion
 - advantages and disadvantages, 904
 - advantages/disadvantages, 506
 - dairy waste, 804–8, 821–4, 833
 - food waste, 346, 348, 388–93
 - fruit/fruit juice waste, 571
 - meat waste, 771–5
 - methods
 - fixed-film, 833
 - thermophilic *see* Thermophilic anaerobic digestion

- Anaerobic digestion (Continued)
two-phase, 833
olive oil waste, 484–7, 501
seafood waste, 872–4, 891–2
vegetable waste, 709–10, 718–22, 731–3,
735, 738, 740–1, 749
wine waste, 420–4
see also Aerobic digestion;
Biodegradation
- Anaerobic fluidized bed reactors, 7
meat waste, 773
- Anheuser-Busch, 59
- Animal feeds, 536–7, 548–9
citrus by-products, 580
dairy waste, 841–2, 848
meat waste, 782–7
seafood waste, 906–7, 918
vegetable waste, 705–7, 729–30
- Anthocyanins, 432–3, 587, 589
- Antibiotics *see* Pharmaceuticals
- Apple by-products
peel, 707
pomace, 586–7, 607, 707, 708, 742
seed, 608
- Apricot by-products, 588
bagasse, 609
stones, 610–11
- Aquaculture
EC Directives, 864
waste *see* Seafood waste
- Arbutus unedo*, 519
- Århus Convention, 153, 154
- Artichoke waste, 717, 737
- Ashbya gossypii*, 728
- Aspergillus awamori*, 442, 867
- Aspergillus niger*, 459, 468, 514–15, 535,
707
- Aspergillus oryzae*, 869
- Aspergillus phoenicis*, 815
- Aspergillus terreus*, 459
- Asymmetric membranes, 377
- Audit, 57, 67, 73
environmental, 68–71
internal, 73, 81–2
- Aureobasidium pullulans*, 438
- Awareness, 77–8
- Azolla pinnata*, 814
- Azotobacter chroococcum*, 534
- Azotobacter vinelandii*, 459, 515
- Bacillus megaterium*, 465
- Bacillus pumilus*, 467, 534, 979
- Bagasse, 590–1
- Banana by-products, 589
- Banking practices, integration of
ISO 14000, 61
- Barcelona Convention for the Protection of
the Mediterranean Sea, 208
- Barley waste, 630–1, 656–7
adsorption, 657
biogas, 657, 688
composting, 656, 657, 688
gasification, 656–7
- Barnard, Charles, 32
- BASF process, 1014–15
- Batteries and accumulators, 383
disposal of, 176, 184
- Beer *see* Brewing industry
- Best available techniques, 959
- Beverage industry, 9
- Bioaugmentation, 368, 458
- Biochemical methane potential, 484,
572, 713
- Biochemical oxygen demand, 356,
659, 712, 767
carbonaceous, 811–12
- Biocidal products, 257–8
- Biodegradation, 715–16
advantages of, 715
cereal waste, 638, 648, 689
polymers, 980–6
vegetable waste, 715–16, 746, 751
see also Aerobic digestion; Anaerobic
digestion
- Biodiesel
cereal waste, 646, 692
corn oil, 645
fruit/fruit juice waste, 572–3
olive oil waste, 519–30
seafood waste, 907–9, 918–19
vegetable waste, 709–10, 725–9, 732,
735–6
- Biodiversity, 225–9
- Bioethanol, 124, 125, 645, 646
cereal waste, 682–4, 692
- Bioflavors, 707, 708
- Biogas, 519–30
cereal waste, 654–5, 657, 661, 680–1,
688, 694

- dairy waste, 818–19, 834–6, 845–6
- seafood waste, 907–9, 910, 918–19
- vegetable waste, 718
- Bio-Gro, 91
- Biological energy recovery systems, 59
- Biological nutrient removal, 819
- Biological oxidation, 384
- Biological oxygen demand, 5, 8, 348, 456, 488, 490, 783, 804
- Biomass, 136–7, 369, 371, 576, 682
- Bio-oil, 669
- Biopiles, 367, 458
- Bioreactors, 359, 458
- Bioremediation, 359–99
 - advantages/disadvantages, 504, 904
 - cereal waste, 647, 692
 - dairy waste, 814–18, 829–32
 - ex-situ*, 359–67
 - biopiles, 367
 - composting, 360–7
 - slurry-phase, 359
 - solid-phase, 359–60
 - in-situ*, 368
 - olive oil waste, 456–8, 491
 - applications, 459–70
 - seafood waste, 867–72, 885
- Biosparging, 368, 458
- Biotechnology, 326
- Bioventing, 368, 458
- Birds, 13
- Blackcurrant pomace, 607, 742
- Blood waste, 783
- Bottling, 108
- Bovine spongiform encephalopathy, 782
- Brewing
 - LCA studies, 101, 108, 109
 - waste products, 7
- Briquetting, 374–5
- BS 7750, requirements of, 58
- Business Charter for Sustainable Development, 42
- Butylated hydroxyanisole, 430, 585
- Butylated hydroxytoluene, 430
- Cactus pear juice, 611
- Caffeolyquinic acid, 717
- California Seminar system, 31
- Canada, legislation, 317–39
 - Clean Air Act 2006, 336, 338
 - Coastal Fisheries Protection Act 1982, 320–1, 337
 - Environmental Assessment Act 1992, 323, 337
 - Environmental Management Act 2003, 331, 338
 - Environmental Management Act 2004, 333
 - Environmental Protection Act 1999, 325–6, 338
 - Foundation for Sustainable Development Technology Act 2001, 328, 338
 - Hazardous Products Act 1985, 322–3, 337
 - Navigable Waters Protection Act 2004, 334
 - Nuclear Fuel Waste Act 2002, 329, 338
 - Nuclear Safety and Control Act 1997, 325, 338
 - Pest Control Products Act 2002, 330, 338
 - Pesticide Control Act 2005, 335, 338
 - Radiation Emitting Devices Act 1985, 321–2, 337
 - Shipping Act 1978, 319–20, 337
 - Water Act 1970, 317–19, 337
 - Wildlife Act 1973-4, 319, 337
- Candida* spp., 871
- Candida tropicalis*, 459–60
- Candida utilis*, 537
- Canola oil, 728–9
- Capitella capitata*, 12
- Carbohydrates, 352
- Carbonaceous biochemical oxygen demand, 811–12
- Carbon dioxide, 171, 194
 - capture, 17
 - equivalents, 312
- Carbon monoxide, 29
- Carbon tetrachloride, 196, 293
- Cardboard waste, 975–80
- Carotenoids, 909–11
- Carrot by-products, 607
 - pomace, 707, 742
 - in beverages, 708
 - as bread improver, 708
- Catalytic cracking, 1012
- Catechins, 587
- Cattle slurry, 719–20
- Ceratocystis acetobutylicum*, 707

- Ceratocystis fimbriata*, 707
- Cereal waste, 629–702
- treatment methods, 631–81
 - adsorption, 637, 657, 688
 - biodegradation, 638, 648, 689
 - bioremediation, 647, 692
 - briquetting of biomass residue, 637
 - chemical activation, 693
 - chemical production, 638
 - combustion, 635, 638, 643, 644, 653, 654, 661, 678–80, 690, 692, 694
 - composting, 632, 637, 639, 641, 651, 656, 657, 660–6, 688, 689, 691, 693
 - enzyme preparation, 693
 - enzymic hydrolysis, 639, 686–7, 691
 - gasification, 636, 642, 643, 655, 656–7, 661, 675–8, 691, 692, 694
 - hydrolysis, 649
 - incineration, 659
 - irradiation, 640
 - pyrolysis, 633, 634, 641, 642, 646, 652, 653, 658, 661, 666–75, 689, 690, 694
 - radiation, 649, 693
 - uses, 681–94
 - biodiesel, 645, 692
 - bioethanol, 645, 646, 682–4, 692
 - biogas, 654–5, 657, 661, 680–1, 688, 694
 - biomass, 682
 - enzyme production, 648
- CERES principles, 52–3
- requirements of, 58
- Cheese *see* Dairy industry
- Chemicals, 13–15
- Chemical activation of cereal waste, 693
- Chemical industry, ISO 14000, 60
- Chemical oxygen demand, 7, 8, 348, 356, 385, 423, 424, 456, 459, 711, 712, 767, 772, 804, 806, 811, 812, 862, 909
- reduction of, 459, 460, 462–3
- Chemical pest management, 121
- Chemical products, 245–69
- biocidal products, 257–8
 - dangerous substances and preparations, 246–53
 - fertilizers, 258–60
 - pesticides, 253–7
 - risk control, 260–4
 - waste management, 264, 266–9
- Chemical recycling, 1015–16
- Chemical sensors, 4
- Cherry pomace, 607, 742
- Chicken manure, 720
- China, 72, 84, 88–9
- Chitosan, 585
- Chlorine, 13
- Chlorofluorocarbons, 194, 196, 293
- Chokeberry pomace, 607, 742
- Circulating bed combustor, 369–70
- Citric acid, 587
- substrates, 585
- Citroflavonoids, 578
- Citrulline, 590
- Citrus by-product feedstuffs, 580
- Citrus fruit waste, 578–86, 609, 612, 616
- animal feeds, 580
 - citric acid substrates, 585
 - dietary fibers, 583–4
 - dye removal, 586
 - juice
 - centrifugation pulp, 582, 592, 598–9
 - leaching waste liquid, 609
 - peel extract, 597
 - grapefruit, 603
 - lemon, 603
 - lime, 608
 - mandarin, 586, 596–7, 603
 - orange, 595, 603, 608
 - peel powder, 600
 - pulp
 - industrial processing, 583
 - solar dried, 580–2, 598
 - solar dried citrus pulp, 580–1
 - toxic heavy metals removal, 586
 - weed control, 580
- Citrus junos*, 580
- treatment, 595
- Citrus reticulata*, 586
- Citrus unshiu* peels, 613
- Clean Air Act 1970, 15
- Clean Air Act Amendments, 4–5
- Clean Water Act, 14
- Climate change, 168–74
- legislation, 171–4
- Clostridia* spp., 715

- Clouding agents, 578–9
- Coagulation
- advantages/disadvantages, 506, 905
 - dairy waste, 812–14, 829
 - food waste, 395–6
 - olive oil waste, 487–8
 - seafood waste, 879, 899–900
- Coastal zone management, 168
- Codigestion of fruit/fruit juice waste, 570–1
- Coffee grounds, 714, 740
- Cold pressed seed oils, 619
- Collagen, 912–14
- Combined heat and power, 20
- Combustion
- cereal waste, 635, 638, 643, 644, 653, 654, 661, 678–80, 690, 692, 694
 - fluidized bed, 471
 - fruit/fruit juice waste, 574–5
 - meat waste, 778–80
 - olive press cake, 522, 523
 - vegetable waste, 734, 749
 - wine waste, 416
- Common Agricultural Policy, 52, 165
- Common Fisheries Policy, 165
- Communication, 78
- Compensation for Oil Pollution in European waters fund, 213
- Competence, 77–8
- Complete mix digester, 395
- Compliance, evaluation of, 80–1
- Compost fertilizer, 434–7
- Composting, 458, 508, 512
- carbon concentration, 363
 - carbon dioxide concentration, 362
 - cereal waste, 637, 639, 641, 642, 651, 656, 657, 661, 685, 688, 689, 691, 693
 - chemical composition, 435
 - dairy waste, 830–1
 - food waste, 351, 356, 357, 360–7
 - fruit/fruit juice waste, 573–4
 - meat waste, 780–2
 - methods
 - aerated static pile, 360
 - horizontal bed reactors, 360–1, 366
 - mechanical, 365
 - mechanically agitated in-vessel, 360
 - plug-flow system, 366
 - rotating drum, 366
 - static pile, 365
 - vertical bed reactors, 360–1, 366–7
 - windrow, 360, 364, 509
- moisture levels, 364
- municipal solid waste, 748
- olive oil waste, 458, 493
- organic matter, 362
- oxygen concentration, 362, 364
- polymer waste, 991–2, 993
- seafood waste, 888–9, 917
- stages of, 363–4
- temperature, 363
- vegetable waste, 722–5, 735, 736, 738, 746–8, 749
- wine waste, 415, 416, 417, 434–7
- Compressed natural gas, 680
- Concentration, 376
- Confined animal feeding operations, 729–30
- Constructed wetlands, 811–12, 826–8
- Consumer Union, agricultural pesticide risk index, 31–2
- Continual improvement, 73, 84
- Convention on Biological Diversity, 225
- Convention on International Trade in Endangered Species of Wild Fauna and Flora, 225
- Convention for the Protection of the Mediterranean Sea against Pollution, 215
- Convention for the Protection of the Rhine, 220
- Copolymers *see* Polymer waste
- Corioloipsis polyzona*, 467
- Corn oil
- as biodiesel, 645
 - chemical treatment, 646
- Corn waste
- bioremediation, 647
 - cob
 - biodegradation, 648
 - chemical activation, 641, 647, 650
 - chemical/physical activation, 643
 - combustion, 644
 - enzyme production, 648
 - gasification, 642
 - hydrolysis, 649
 - pyrolysis, 642, 646
- combustion, 643, 644
- composting, 641

- Corn waste (Continued)
 - ethanol and biodiesel, 645
 - gasification, 643
 - husk, enzyme preparation, 648
 - stalk, pyrolysis of, 641
 - starch, gasification, 643
 - stover
 - biodiesel and ethanol production, 646
 - bio-ethanol, 684
 - chemical activation, 649
 - combustion, 644
 - physical activation, 649
 - pyrolysis, 642
 - radiation, 649
 - straw, pyrolysis of, 634, 641
- Corporate image, 88
- Corrugated paperboard, 119
- Cosmetics
 - olive oil waste, 533–6, 547–8
 - seafood waste, 911–16, 920–2
- Cost-benefit analysis, 19–20
- Covered lagoon digester, 395
- Cranberry by-products, 590, 599–600
 - pomace, 590
- Critical surface time model, 121
- Cryo-comminution, 1006
- Crystallization, 376

- Dacrymyces stellatus*, 537
- Dairy industry, 6–7, 801–2
 - inputs and outputs, 844, 850–1
 - LCA studies, 101, 108–12
 - processes involved in, 803
 - use of seafood waste in, 911–12
- Dairy waste, 801–60
 - treatment methods, 804–19, 821–33
 - acid hydrolysis, 832
 - aerobic digestion, 804, 821
 - anaerobic digestion, 804–8, 821–4, 833
 - bioremediation, 814–18, 829–32
 - coagulation, 812–14, 828–9
 - composting, 830–1
 - constructed wetlands, 811–12, 826–8
 - electrocoagulation, 812–14, 828–9
 - enzymatic hydrolysis, 818, 825
 - fermentation, 830, 831
 - flocculation, 812–14, 828–9
 - lactose adsorption, 833
 - membrane processes, 808–11, 824–6
 - precipitation, 812–14, 828–9
 - uses, 819–20, 834–44
 - animal feedstuff, 841–2, 848
 - biogas/methane/hydrogen production, 818–19, 834–6, 845–6
 - fertilizer, 836–41, 846–8
 - food industry, 842–3, 849
- Dangerous substances and preparations, 246–53
- DDT in dairy products, 6–7
- Dehydration of vegetable waste, 745–6, 751
- DIAGE, 52
- DIALECTE, 52
- DIALOGUE, 52
- Dicaffeoylquinic acid, 717
- Dichlorodiphenyltrichloroethane, 215
- Dietary fibers, 583–4
 - drying, 584–5
 - dry milling, 585
 - washing, 584
 - wet milling, 584
- Digestion
 - aerobic *see* Aerobic digestion
 - anaerobic *see* Anaerobic digestion
- Dioxins, 251
- Discharges of substances, 220–3
 - digester designs, 395
- Dissolved air flotation, 10
 - meat waste, 770, 771
- Distillation
 - advantages/disadvantages, 506
 - food waste, 396–7
 - olive oil waste, 488–90, 503
- Distillery waste, 8–9
- Documentation, 57, 66–7, 78–9
- Drop-off centers, 998
- Dry milling, 585
- Dye removal, 586

- Earthworms, 12–13
- Eco-design, 144
- EcoIndicator 95, 108
- Ecolabeling, 30, 116
- Ecological treatment systems, 827
- Eco-Management and Audit Scheme *see* EMAS
- Effects identification matrix, 47
- Eichhornia crassipes*, 814

- Electrically charged membrane, 377
- Electrocoagulation of dairy waste, 812–14, 828
- Electrodialysis
- food waste, 347, 350, 379–80
 - olive oil waste, 481
 - wine waste, 416
- Electrolysis
- advantages/disadvantages, 505
 - food waste, 382–3
 - applications, 383
 - olive oil waste, 481–2, 502
- Electrometallurgy, 383
- Electroplating, 383
- Electrorefining, 383
- Electrostatic separation, 1007–8
- EMAS, 54–5, 90, 143–4
 - requirements of, 58
- Emergency procedures, 79–80
- Emissions, 4–6
 - factors affecting cost of, 100
- Emission limits, 137
- EMS *see* Environmental management systems
- Energy efficiency indicators, 765
- Energy recovery, 99
 - meat waste, 787–90
 - vegetable waste, 713, 739
- Energy renewability efficiency, 124
- Ensiling
- fish waste, 869, 871
 - fruit/fruit juice waste, 575
 - seafood waste, 889–90
 - vegetable waste, 705
- Entrained flow gasifiers, 374
- Environmental aid, 148
- Environmental attitudes, 15–16
- Environmental audit, 68–71
 - choice of supplier, 69–70
 - continuous environmental improvement, 69
 - contractual requirements, 70
 - costs of implementation, 71
 - EMS implementation and maintenance, 69
 - ISO 14001 certification criteria, 68
 - management and employee awareness, 71
 - objectives, 68
 - policies and objectives, 69
 - public perception, 70
 - quality control, 70
 - reducing costs, 69
 - regulatory compliance, 68–9
 - spotting potential problems, 69
- Environmental awareness, 40–3
- Environmental crime, 154
- Environmental decision traps, 84
- Environmental effects statement, 23
- Environmental impact assessment, 16, 19–33, 72
- Air Pollution Index, 28–9, 30
- audit framework, 26
- computer models, 21
- process of, 22
- report structure, 24–5
- trends and indicators, 27–8
- Environmental Impact Quotient, 31
- Environmental Impact Statement, 23
- Environmental levies, 147
- Environmental load value, 106
- Environmental management cycle, 64
- Environmental management systems, 3–38, 39–40, 45–9, 50–1
 - criteria and issues, 47–9
 - current state of implementation, 4
 - definition, 45
 - first steps, 46
 - implementation and maintenance, 69
 - see also* ISO 14000
- Environmental monitoring, 146
- Environmental performance, 73
- Environmental performance indicators, 66
- Environmental policy, 45–7, 74
- Environmental protection
 - biodiversity, 225–9
 - European legislation, 223, 225–44
 - fauna and flora, 229–35
 - forests, 235–9
 - genetically modified organisms, 239–44
 - US legislation, 294–5
- Environmental Protection Act 1990, 14, 942
- Environmental Protection Agency, 54
- Environmental purchasing, 88
- Environmental Quality Objectives, 863–4
- Environmental Quality Standards, 864
- Environmental Risk Index, 137
- Environmental statement, 23
- Environmental technology, 160

- Environmental Technology Initiative, 42
 COM(2003) 572, 162
- Environment-related headline indicators, 161
- Enzymatic hydrolysis
 cereal waste, 639, 686–7, 691
 dairy waste, 825, 828
- Enzyme preparation, 648
 cereal waste, 693
- Epicatechin, 587
- Epicatechin gallate, 587
- Epichlorohydrine, 576
- Epigallocatechin, 587
- Eriocitrin, 580
- Essential amino acids, 783
- EU *see* European Union
- Euc-1, 462
- Euratom, 190
- European Chemicals Agency, 252
- European Climate Change Program,
 171, 174
- European Community *see* European
 Union
- European Environment Agency, 142, 454
- European Union, 135–288
 air pollution, 192–206
 COM(2002) 595, 204
 Decision 81/462/EEC, 194
 Decision 97/101/EC, 196, 198
 Decision 280/2004/EC, 173, 175
 Decision 1753/2000/EC, 201, 205
 Decision 2001/379/EC, 197, 199
 Decision 2002/358/EC, 172, 175
 Directive 70/220/EEC, 199, 202
 Directive 82/884/EEC, 194, 197
 Directive 85/203/EEC, 195, 197
 Directive 88/77/EEC, 199, 202
 Directive 92/3/Euratom, 191, 193
 Directive 93/12/EEC, 200, 203
 Directive 94/63/EC, 205, 207
 Directive 96/61/EC, 205, 207
 Directive 96/62/EC, 195
 Directive 97/68/EC, 200, 201, 203
 Directive 98/70/EC, 200, 203
 Directive 1999/13/EC, 206, 207
 Directive 1999/30/EC, 195, 197
 Directive 1999/94/EC, 200, 204
 Directive 2000/25/EC, 200, 204
 Directive 2001/80/EC, 206, 207
 Directive 2001/81/EC, 195–6, 198
 Regulation No 1493/93, 190, 193
 Regulation No 2037/2000, 196, 198
 Regulation No 3093/94, 196
- chemical products, 245–69
 COM(2001) 88, 249, 255
 COM(2001) 0237, 250, 255
 COM(2001) 593, 250, 255
 COM(2002) 349, 257
 COM(2003) 320, 266
 COM(2005) 20, 251, 256
 Decision 93/98/EEC, 267, 269
 Decision 97/640/EC, 268, 269
 Decision 2003/106/EC, 251, 256
 Directive 76/116/EEC, 258, 260
 Directive 76/769/EEC, 246, 254
 Directive 80/876/EEC, 259, 260
 Directive 91/689/EEC, 264, 269
 Directive 96/59/EC, 266, 269
 Directive 96/62/EC, 260, 265
 Directive 98/8/EC, 257, 258
 Directive 98/24/EC, 261, 265
 Directive 1967/548/EEC, 246, 254
 Directive 1999/45/EC, 246, 254
 Directive 2004/9/EC, 262
 Directive 2004/10/EC, 263, 265
 Regulation No 304/2003, 247, 254
 Regulation No 648/2004, 248, 255
 Regulation No 793/93, 263, 265
 Regulation No 2003/2003, 259, 260
- climate change, 168–74
 COM(1998) 333, 165, 168
 COM(1999) 22, 165, 168
 COM(2001) 580, 175
 COM(2003) 492, 171–2, 175
 Directive 2003/87/EC, 171, 175
 COM(2001) 31, 140
 COM(2002) 17, 140, 141
- Common Agricultural Policy, 52, 165
- Common Fisheries Policy, 165
- Directive 91/156/EEC (Waste), 942
- Directive on Access to Environmental
 Information, 138
- Drinking Water Directive, 11
- environmental aid, 148
- Environmental Impact Assessment
 Directive, 138
- environmental instruments, 141–52
 COM(2001) 68, 144, 150
 COM(2002) 412, 144, 150

- COM(2003) 334, 150
 COM(2003) 338, 145–6, 150
 COM(2004) 634, 146, 151
 Decision 446/2002/EC, 146, 151
 Decision 2004/210/EC, 147, 151
 Directive 85/337 (environmental impact assessment), 20, 145
 Directive 2001/42/EC, 141, 149
 Regulation 1210/1990, 142, 149
- environmental law, 152–8
 COM(2001) 139, 153, 157
 Decision 2003/80/JHA, 153
 Directive 90/313/EC, 152, 157
 Regulation No 761/2001, 143, 149
 Regulation No 1655/2000, 142, 149
 Regulation No 1980/2000, 143, 149
 SEC(2002) 1041, 155, 158
 SEC(2003) 804, 156, 158
 SEC(2004) 1025, 156, 158
- environmental protection, 223, 225–44
 COM(2003) 572, 233, 237
 Decision 81/691/EEC, 234
 Decision 82/72/EEC, 226, 230
 Decision 82/461/EEC, 234, 237
 Decision 93/626/EEC, 226, 230
 Decision 1999/337/EC, 235, 237
 Directive 79/409/EEC, 229, 236
 Directive 83/129/EEC, 229, 236
 Directive 86/609/EEC, 231, 236
 Directive 90/219/EEC, 239, 244
 Directive 92/43/EEC, 225, 230
 Directive 1999/22/EC, 231, 236
 Directive 2001/18/EEC, 241, 244
 Regulation No 258/97, 241, 244
 Regulation No 338/97, 232, 237
 Regulation No 348/81, 231, 237
 Regulation No 1830/2003, 244
 Regulation No 1946/2003, 243, 244
 Regulation No 2152/2003, 238, 240
 Regulation No 2494/2000, 240
- general legislative provisions, 138–58
- marine aquaculture
 Directive 76/464/EEC (Hazardous Substances), 864
 Directive 79/409/EEC (Wild Birds), 864
 Directive 79/923/EEC (Quality of Shellfish Growing Waters), 864
 Directive 85/337/EEC (Environmental Impact Assessment), 864
 Directive 92/43/EEC (Species and Habitats), 864
 Directive 97/11/EEC (Environmental Impact Assessment), 864
 Directive 2000/60/EC (Water Framework), 864
 Directive 2001/42/EEC (Strategic Environmental Assessment), 864
 Recommendation 2002/413/EC, 168, 170
 Regulation No 259/93, 178, 181
 Regulation No 1830/2003, 242, 243
 Regulation No 2150/2002/EC, 178, 179, 182
- Sanitary and Phytosanitary Agreement, 140
- Scientific Committee on Consumer Products, 147
- Scientific Committee on Emerging and Newly Identified Health Risks, 147
- Scientific Committee on Health and Environmental Risks, 147
- Severo II Directive, 156
- soil protection, 270–1
 COM(2002) 179, 271
 Directive 96/61/EC, 270, 271
- Standard EN 1720 (Adhesives for Paper and Board Packaging and Disposal Sanitary Products Determination of Dispersibility), 976
- sustainable development, 158–68
 COM(2001) 264, 161
 COM(2002) 82, 159, 160
 COM(2002) 122, 160, 164
 COM(2002) 186, 165, 169
 COM(2002) 524, 161, 164
 COM(2003) 301, 162, 164
 COM(2003) 572, 164
 COM(2003) 662, 153, 157
 COM(2003) 829, 159, 161
 COM(2004) 38, 162
 COM(2004) 60, 166, 169
 Regulation No 2493/2000, 163, 169
- Urban Waste Water Treatment
 Directive, 135
- waste management, 174, 176–92
 COM(2003) 32, 190, 193
 COM(2003) 250, 182

- European Union (Continued)
- COM(2003) 301, 179, 182
 - COM(2003) 319, 188
 - COM(2004) 162, 188
 - Decision 93/98/EEC, 189, 191
 - Decision 97/640/EC, 191
 - definition of waste, 135
 - Directive 75/439/EEC (waste oils), 176, 178, 179, 180, 186
 - Directive 75/442/EEC, 176, 178, 179, 181
 - Directive 78/176/EEC, 183, 186
 - Directive 82/883/EEC, 183, 186
 - Directive 86/278/EEC, 179, 183, 186
 - Directive 91/157/EEC, 176, 184, 186
 - Directive 91/689/EEC (hazardous waste), 178, 179, 189, 191
 - Directive 92/112/EEC, 184, 187
 - Directive 94/62/EC (packaging and packaging waste), 178, 184
 - Directive 94/67/EC, 185, 187, 189
 - Directive 96/59/EC, 184, 187
 - Directive 96/61/EC, 177, 181
 - Directive 1999/31/EC (waste), 176, 177, 181, 356
 - Directive 2000/53/EC, 185, 187
 - Directive 2000/76/EC, 188, 189
 - Directive 2002/95/EC, 185, 187
 - Directive 2002/96/EC, 185, 187
 - water protection and management, 206–23
 - COM(2000) 80, 213
 - COM(2000) 802, 217
 - COM(2001) 615, 221
 - COM(2002) 539, 213, 217
 - COM(2003) 92, 214
 - Decision 21 79/98/EC, 139, 140
 - Decision 77/585/EEC, 208, 214, 217
 - Decision 81/420/EEC, 214, 218
 - Decision 83/101/EEC, 214, 218
 - Decision 84/132/EEC, 214, 218
 - Decision 94/156/EC, 215, 219
 - Decision 94/157/EC, 215, 219
 - Decision 95/308/EC, 220, 221
 - Decision 98/249/EC, 215, 219
 - Decision 1999/800/EC, 214
 - Decision 1999/801/EC, 215, 218
 - Decision 1999/802/EC, 215
 - Decision 2000/706/EC, 220, 221
 - Decision 2002/762/EC, 216, 219
 - Decision 2004/575/EC, 218
 - Decision 2005/370/EC, 154, 157
 - Decision 2455/2001/EC, 209, 210
 - Decision 2850/2000/EC, 216, 219
 - Directive 75/440/EEC, 212
 - Directive 76/160/EEC (bathing water), 207
 - Directive 76/464/EEC, 220, 224
 - Directive 78/659/EEC, 211
 - Directive 78/659/EEC (aquaculture water), 207, 212
 - Directive 79/869/EEC, 211, 212
 - Directive 80/68/EEC, 221, 224
 - Directive 82/176/EEC, 222, 224
 - Directive 91/76/EEC, 208
 - Directive 91/271/EEC (urban waste-water treatment), 208, 211, 213
 - Directive 91/676/EEC, 222, 224
 - Directive 96/61/EC, 222, 224
 - Directive 98/38/EC, 212
 - Directive 98/83/EC (drinking water), 207
 - Directive 2000/60/EC, 208, 210
 - Regulation No 648/2004, 223, 224
 - Regulation No 782/2003, 211, 217
 - Eutrophication, 454
 - Eutrophication potential, 110, 195–6
 - EVABAT, 52
 - Evaporation, 375–6
 - advantages/disadvantages, 504–5, 905
 - applications, 376
 - food waste, 375–6
 - olive oil waste, 479–80
 - seafood waste, 897–8
 - Expanded polystyrene, 119
 - Extended Producer Responsibility, 291
 - Extracellular matrix proteins, 782
 - Fatty acid methyl esters, 726
 - Fauna and flora, 229–35
 - Federal Insecticide, Fungicide and Rodenticide Act, 31
 - Feedstock recycling, 99, 124, 126, 1010–15
 - BASF process, 1014–15
 - catalytic cracking, 1012
 - Duales System, 1012
 - gas production, 1013–14
 - Kohleol-Anlage Bottrop, 1013

- reduction process, 1015
- Fermentation, 7–9
 - brewery waste, 7
 - dairy waste, 829–30, 831
 - distillery waste, 8–9
 - seafood waste, 885–8
 - winery waste, 7–8
- Fertilizers, 258–60
 - compost *see* Composting
 - dairy waste, 836–41, 846–8
 - olive oil waste, 490, 507–19, 540–4
- Ferulic acid, 707–8
- Feruloyl esterase, 686
- Fish *see* Seafood products
- Fish bioassays, 837–8
- Fishmeal production, 863
- Fish oil production, 863, 876–8, 895–7
- Fish waste *see* Seafood waste
- Fixed bed gasifiers, 374
- Flash pyrolysis, 667, 668
- Flavanoids, 9–10, 430, 431
- Flavanols, 429
- Flavonol glycosides, 587
- Flocculation
 - advantages/disadvantages, 506, 905
 - dairy waste, 812–14
 - food waste, 395–6
 - olive oil waste, 487–8
 - seafood waste, 879, 899–900
- Flue gas, 29
 - desulfurization by-product, 968
- Fluidized bed bioreactor, 389
- Fluidized bed combustion, 471
 - fruit/fruit juice waste, 574–5
 - vegetable waste, 717–18
- Fluidized bed furnace, 373, 473
- Fluidized bed gasifiers, 374, 474
- Fluidized bed incineration, 369, 370–1
- Food industry, 6–9
 - ISO 14000, 59
 - LCA studies, 101–4
 - waste use in
 - dairy waste, 842–3, 849
 - seafood waste, 911–16, 920–2
 - see also individual sectors*
- Food packaging, LCA studies, 102–3, 107, 109, 119
- Food packaging waste, 939–1045
 - aluminum, 958–75
 - glass, 13–15, 950–8
 - cullet, 951
 - international situation, 951–2
 - recycling, 947, 953–5
 - paper/carton, 975–80
 - polymers, 980–1023
- Food waste, 345–410
 - aerobic biodegradation, 346, 349, 350
 - aerobic digestion, 348, 393–5
 - anaerobic digestion, 346, 348, 388–93
 - thermophilic, 346, 350
 - composting, 351, 356, 357
 - electrodialysis, 347, 350, 379–80
 - electrolysis, 382–3
 - evaporation, 375–6
 - gasification, 373–4
 - incineration, 349, 368–71
 - landfill, 176
 - membrane processes, 376–82
 - ozonation, 346, 347, 349, 384–6
 - pyrolysis, 351, 354, 371–3
 - sequencing batch reactor, 346, 347, 349, 397–8
 - solid-state fermentation, 350, 398–9
 - ultrasound irradiation, 397
 - wet oxidation, 348, 351, 386–8
- Forestry, 235–9
 - ISO 14000, 60–1
 - sustainable management, 239
- Fruit/fruit juice by-products, 586–619
 - almond, 608, 708–9, 731
 - apple pomace, 586–7
 - apricot, 10–11, 588, 609
 - banana, 589
 - cranberry, 590
 - grape *see* Grape by-products
 - grapefruit, 603
 - guava, 589
 - hawthorn, 594, 619
 - kiwifruit, 589–90
 - lemon, 603, 606
 - lime, 608
 - mandarin, 586, 596–7, 603
 - mango, 588, 707, 713
 - oranges *see* Orange by-products
 - papaya, 589
 - passion fruit, 586, 589, 596–7
 - peach and apricot, 588
 - pineapple, 588–9

- Fruit/fruit juice by-products (Continued)
 - sugar beet, 590–4
 - watermelon, 590, 600, 608
- Fruit/fruit juice waste, 569–628
 - industrial water effluent treatment, 575–8
 - membrane technologies, 576–7
 - subcritical water extraction, 578, 579
 - supercritical fluid extraction, 577–8
 - treatment, 570–5, 596, 597–8
 - anaerobic digestion, 571
 - biodiesel production, 572–3
 - codigestion, 570–1
 - comparison of methods, 619
 - composting, 573–4, 612
 - ensiling, 575
 - fluidized bed combustion, 574–5
 - grape pomace de-stemming, 570
 - uses *see* Fruit/fruit juice by-products; and individual fruits
 - see also* Citrus fruit waste; Vegetable waste
- Fruit and vegetable industry, 9–10
 - LCA studies, 101
- Gallotannins, 588
- Ganoderma* spp., 536
- Garden waste, composting, 612, 724
- Gasification, 373–4, 520, 672
 - advantages/disadvantages, 504
 - cereal waste, 636, 642, 643, 655, 656–7, 661, 675–8, 691, 692, 694
 - entrained flow gasifiers, 374
 - fixed bed gasifiers, 374
 - fluidized bed gasifiers, 374, 474
 - food waste, 373–4
 - olive oil waste, 471–3
- Gas separation
 - food waste, 380–1
 - olive oil waste, 481
- Genetically modified organisms, 239–44
- Geneva Convention on Long-Range Transboundary Air Pollution, 194
- Geothermal energy, 17–18
- Geotrichum candidum*, 459
 - reduction of chemical oxygen demand by, 462–3
- Germany, 91–2
- Glaciers, 27
- Glass, 13–15
 - cullet, 951
 - packaging, 950
 - recycling, 947, 953–5
 - environmental aspects, 955–8
 - international situation, 951–2
- Global warming, 170
- Global warming potential, 110
- Glycera americana*, 12
- Go Green Team, 15
- Good Laboratory Practice, 262–3
- Grape by-products
 - bagasse, 442
 - marc, 418, 599
 - pomace, 413, 442, 587–8, 707
 - de-stemming, 570
 - treatment, 595–6
 - seed extracts, 413, 415
 - antioxidant properties, 432
 - seed oil, 430–1, 587
 - skin pulp, 418
- Grapefruit peel, 603
- Greenhouse effect, 17
- Greenhouse gases, 27, 110, 168, 170
- Greenhouse gas emissions, 137, 171, 173
- Green purchasing, 88
- Guava by-products, 589
- Halogenated aliphatic hydrocarbons, 194
- Halogenated ethers, 194
- Halons, 196, 293
- Hawthorn fruit, 594, 601, 619
- Hazard analysis and critical control points, 4
- Hazardous air pollutants, 4–5
- Hazardous waste, 189–90
- Health monitoring, 146
- Heart for Wood campaign, 61
- Heavy metal removal
 - adsorption, 439–44, 530–3, 790–2
 - citrus fruit waste in, 586
 - coffee grounds, 714
- Herbicides, 10
 - olive oil waste, 537–8
- Hesperidin, 9, 580, 585
- Heteromastus filiformis*, 12
- Homogeneous membranes, 377
- Household waste, 124
- Hydraulic retention time, 570, 709, 720, 773
- Hydrobromofluorocarbons, 196
- Hydrochlorofluorocarbons, 196

- Hydrocyclone, 1001
- Hydrofluorocarbons, 171
- Hydrogen production, 519–30
dairy waste, 834–6, 845–6
- Hydrolysis
advantages/disadvantages, 904
cereal waste, 649
dairy waste, 818
seafood waste, 865–7, 868, 883–5
- Hydropower, 17–18
- Hydroxytyrosol, 537
removal of, 461
- Hyphoderma* spp., 536
- IDEA, 52
- IMPEL, 154
- Incineration, 136, 137, 176,
185, 188–9
advantages/disadvantages, 504
cereal waste, 659
circulating bed combustor, 369–70
fluidized bed, 369, 370–1
food waste, 349, 368–71
infrared combustion, 371
olive oil waste, 470–1
polymer waste, 988–9
rotary kilns, 371, 472
wine waste, 416, 424–5
- INDIGO, 52
- Industrial water effluent treatment, 575–8
membrane technologies, 576–7
subcritical water extraction, 578
supercritical fluid extraction, 577–8
- Infrared combustion, 371
- Inland water, 220
- Input-output energy analysis
dairy industry, 844, 850–1
food packaging, 944
olive oil production, 552–3
seafood industry, 924–6
- Insecticides, 11
- Integrated pest management, 121
- Integrated Pollution Prevention and Control
(IPPC), 14
- Intergovernmental Panel on Climate Change,
25, 170
- Internal audit, 73, 81–2
- International Dolphin Conservation
Program, 235
- International Institute for Sustainable
Development, 292
- International Maritime Organization, 201
- International Protocols on Acidifying
Substances, 194
- International Standard Organization *see* ISO
- Irradiation of cereal waste, 640, 649, 693
- ISO 9000, 40, 63
vs ISO 14000, 55–8
- ISO 13600, 99
- ISO 14000, 39–96
applications of, 59–61
chemical industry, 60
food industry, 59
forestry and agriculture, 60–1
and banks, 61
benefits of implementation, 49–50
development of, 51
environmental audit, 68–71
and environmental protection, 50–1
evolution of, 44
and governments, 62
implementation, 63–8
audit, management reviews, correction
and follow-up, 67
certification, 68
continual improvement, 68
documentation, 66–7
initial assessment and definition of
purpose, 63
objectives and targets, 66
policy preparation, 63, 66
programs, 67
requirements of, 58
vs CERES principles, 52–3
vs Eco-Management and Audit Scheme,
54–5
vs ISO 9000, 55–8
vs Responsible Care, 52
worldwide certification, 41
- ISO 14001:24, 71–2
comparative table of changes, 73–83
checking, 80–2
definitions, 73
environmental policy, 74
general requirements and scope, 74
implementation and operation, 77–80
management review, 82–3
planning, 75–7

- ISO 14004, 43
 - case studies, 72–92
- ISO 14040, 97–132
- ISO 14041, 98
- ISO 14042, 98
- ISO 14043, 98
- ISO Environmental Management Standards, 60

- Johannesburg Summit, 160

- Keidahren Charter, 58
- Kellogg, 59
- Ketchup production, LCA studies, 101, 107
- Kiwifruit by-products, 589–90
- Kyoto Protocol, 171, 173, 194

- Laccase, 465, 468, 469, 470
- Lactobacillus* spp., 398, 443, 715
- Lactobacillus plantarum*, 464, 871, 873
- Laminar entrained flow reactors, 670
- Landfarming, 359–60, 458
- Landfill
 - estimation of gas generation, 353
 - food waste, 176
 - polymer waste, 987–8
 - stages of, 352
- Langmuir isotherms, 440
- LCA *see* Life cycle assessment
- LCIA *see* Life cycle impact assessment
- Lead, 194
- Legislation, 133–288
 - Canada, 317–39
 - EU-related, 136–288
 - United States, 293–317
- Lemma minor*, 814
- Lemon juice by-products, 606
- Lemon peel, 603
- Lentinula edodes*, 470
- Lentinus tigrinus*, 467
- LIFE, 142–3
- Life cycle assessment, 97–132, 144
 - applications, 105–6
 - case studies, 106–26
 - definition, 97–8
 - focus of, 98
 - future strategy, 126–8
 - structure, 98–9
 - studies on food production systems, 99–106
- Life cycle impact assessment, 106, 107
- Life cycle inventories, 112–13, 114, 144
- Ligno-cellulosic substrate, 671
- Lime peel, 608
- Lipids, 352
- Liquid membranes, 377
- Long-chain fatty acids, 571, 772
- Luteolin galactoside, 717
- Luteolin glucuronide, 717

- Macro-separation, 999
- Maize, 630
- Malaysia, 91
- Management review, 82–3
- Mandarin peel, 586, 596–7, 603
- Mango by-products, 588
 - kernel flour, 707
 - peel, 707
 - methane production, 713
- Manure Action Plan, 724
- Marine pollution, 211–19
- Marine underwater depuration system, 875
- Mass allocation, 107
- Mass balance, 47
- Material flow diagram, 47
- Materials efficiency, 943
- Maximum achievable control technology, 5
- Meat and bone meal, 783
- Meat and poultry industry, 10
 - energy consumption, 766
 - LCA studies, 101
- Meat waste, 765–800
 - characteristics of, 768
 - composition of, 786
 - mineral content, 788
 - nutritional content, 787
 - treatment, 768–71
 - aerobic digestion, 775–8
 - anaerobic digestion, 771–5
 - composting, 780–2
 - thermal treatments, 778–80
 - uses, 782–92
 - animal feeds, 782–7
 - energy recovery, 787–90
 - heavy metal adsorption, 790–2
- Mechanically agitated in-vessel composting, 360

- Mechanical recycling, 1008–10
- Meloidogyne* spp., 507
- Membrane processes
- advantages and disadvantages, 904
 - advantages/disadvantages, 505
 - dairy waste, 808–11, 824–6
 - food waste, 376–82
 - industrial water effluent treatment, 576–7
 - methods
 - asymmetric membranes, 377
 - electrically charged membrane, 377
 - homogeneous membranes, 377
 - liquid membranes, 377
 - microporous membranes, 376–7
 - olive oil waste, 480–1
 - seafood waste, 874–5, 892–4
 - separation processes, 378–82
 - electrodialysis, 379–80, 481
 - gas separation, 380–1, 481
 - microfiltration, 379, 481
 - nanofiltration, 378–9, 481
 - pervaporation, 382, 481
 - reverse osmosis, 378, 481
 - ultrafiltration, 378, 481
- Mesophilic digestion, 392
- Methane production, 171
- dairy waste, 834–6, 845–6
 - vegetable waste, 713, 739
- see also* Biogas
- Methyl bromide, 196
- Methyl chloroform, 293
- Microencapsulation, 660
- Microfiltration
- food waste, 379
 - olive oil waste, 481
- Microporous membranes, 376–7
- Micro-separation, 999
- Milk *see* Dairy industry
- Molten salt destruction, 373
- Monacus purpureus*, 869
- Monocyclic aromatics, 194
- Monsanto Corporation, 61
- Montreal Protocol, 292, 293
- Motor vehicle pollution, 199–205, 292
- Multistaged enthalpy extraction technology (MEET), 834
- Municipal solid waste, 136, 137, 723, 744
- caloric values, 352
 - composting, 748
 - fruit and vegetable fraction, 721
 - organic fraction, 570–1, 709
 - proximate analysis, 352
- Nanofiltration
- dairy waste, 809, 824, 826
 - food waste, 378–9
 - olive oil waste, 481
- Naringin, 9, 580
- Narirutin, 580, 585
- National Pollutant Discharge Elimination System, 14
- Neutral detergent fiber, 580
- Neutralization, 660
- New Zealand, 91
- Nitrogen, 665
- Nitrogen dioxide, 29, 195
- Nitrogen mineralization, 712–13
- Nitrogen oxides, 194, 195, 196
- Nitrous oxide, 171
- Non-conformity, 81
- Non-governmental organizations, 146
- Oat waste, 631, 658
- Occupational Safety and Health Administration, 54
- Odor control, 356–7
- Olive bagasse, pyrolysis, 525
- Olive mill solid residue, 467
- Olive mill wastewaters, 454–6
- composting, 464–6
 - decolorization of, 467–8, 492, 493, 494, 495
 - depolymerization of, 464
 - detoxification of, 462
 - parameters of, 458
 - re-use of, 538–9
 - treatment, 459–70, 491–503
- Olive oil production, 116, 118–19, 454–6
- inputs and outputs, 552–3
- Olive oil waste, 453–568, 713
- applications
 - animal feed, 536–7, 548–9
 - antioxidants, 538
 - biogas/biodiesel/hydrogen production, 519–30, 544–6
 - fertilizer, 490, 507–19, 540–4
 - food industry/cosmetics, 533–6, 547–8

- Olive oil waste (Continued)
 - herbicides, 537–8
 - wastewater treatment, 530–3, 546–7
 - thermal treatments, 470–81
 - applications, 473–9
 - evaporation, 479–80
 - gasification, 471–3
 - incineration, 470–1
 - membrane processes, 480–1
 - pyrolysis, 471, 497
 - treatment
 - advantages and disadvantages, 504–7, 539, 550–2
 - bioremediation, 456–70, 491
 - coagulation, 487–8
 - composting, 458, 493
 - digestion, 483–7, 501, 527
 - distillation, 488–90, 503
 - electrolysis, 481–2, 502
 - flocculation, 487–8
 - ozonation, 482–3, 500
 - precipitation, 487–8
- Olive press cake
 - combustion, 522, 523
 - as energy source, 520–1
 - as fertilizer, 510–12, 517
 - pre-treatment, 538
 - pyrolysis, 521, 524
- Olive tree branches, 510–11
- Onion peels, 713
- Operational control, 79
- Optical recycling, 1000–1
- Orange by-products, 603, 613
 - ensiled sliced, 604
 - peel, 595, 603, 608, 614, 618–19, 707
 - dehydrated, 616
 - pulp wash, pigmented, 607
- Organic loading rate, 710–11, 773
- Organochlorine pesticides, 194
- Oscillatoria cf. chalybea*, 12
- OSPAR Convention for the Protection of the Marine Environment of the North-East Atlantic, 176
- Oxysporus* spp., 536
- Ozonation
 - advantages/disadvantages, 505
 - food waste, 346, 347, 349, 384–6
 - olive oil waste, 482–3, 500
 - wine waste, 426–7
- Ozone, 29, 194
- Ozone layer, 193
- Palm oil mill effluents, 576–7, 616–17
- Papain, 589
- Papaya by-products, 589
- Paper industry, LCA studies, 119, 120
- Paper waste, 526, 975–80
 - LCIA, 978–9
 - recycling, 948, 975–80
- Paris Convention for the Protection of the Marine Environment of the North East Atlantic, 208
- Passion fruit, 586
 - by-products, 589
 - treatment, 596–7
- Payback centers, 998
- PCBs *see* polychlorinated biphenyls
- PCDDs *see* polychlorinated dibenzo-*p*-dioxins
- PCDFs *see* polychlorinated dibenzofurans
- Peach by-products, 588
 - meal, 608
 - stones, 610–11
- Pear pomace, 607, 742
- Pectic acid, 576
- Pectin, 588
- Pectinase, 612
- Pediococcus acidilactici*, 871
- Penicillium decumbens*, 8
- Percolating filter, 659
- Perfluorocarbons, 171
- Persipan, 588
- Pervaporation
 - food waste, 382
 - olive oil waste, 481
- Pesticides, 10
 - European legislation, 253–7
 - LCA studies, 103, 121–2
 - US legislation, 294
- Pesticide drift, 11
- Pesticide risk indicators, 30, 32
- Petrochemical wastewater, anaerobic treatment, 14
- Phanerochaete chrysosporium*, 398, 399, 443, 459, 536, 539
- Phanerochaete flavido-alba*, 466, 469
- Pharmaceuticals, environmental effects, 126, 127

- Phenolic acids, 587
- Phenolic compounds, antioxidant activity, 535
- Phenol oxidase, 462, 539
- Phenol Toxicity Index, 467
- Phlebia radiata*, 536
- Phthalate acid esters, 194
- Phytochemicals, 707
- artichoke, 717
- Phytophthora* spp., 714
- Pigments
- orange pulp, 607
 - seafood waste, 909–11, 919–20
- Pineapple by-products, 588–9, 617
- juice, 617
- Planning, 75–7
- environmental aspects, 75
 - legal/environmental requirements, 75–6
 - objectives, targets and program(s), 76–7
- Plastic packaging, 943
- Plastic recycling, 994–8
- collection of recyclable materials, 997
 - drop-off centres, 998
 - payback centers, 998
- Pleurotus* spp., 398, 443, 461–2
- Pleurotus ostreatus*, 465, 469, 536
- Pleurotus sajor caju*, 467
- Plug-flow digester, 395
- Plug-flow system composting, 366
- Politics, 15–16
- Pollutant release and transfer register, 146
- 'Polluter pays' principle, 140, 147, 291
- Pollution, 4
- effects on organisms, 12–13
 - LCA studies, 104
 - prevention of, 73
- Polychlorinated biphenyls, 6, 11, 194, 215, 250–1, 266–7, 303
- disposal of, 184
- Polychlorinated dibenzofurans, 11, 136
- Polychlorinated dibenzo-*p*-dioxins, 11, 136
- Polychlorinated terphenyls, 215
- Polymerin, 517, 532
- Polymer waste, 980–1023
- biodegradable synthetic copolymers/composites, 980–6
 - biacid, diamine and α -amino acid based, 981–2
 - ϵ -caprolactone and nylon salts, 982–3
 - composite materials, 984
 - natural-synthetic polymer blends, 984
 - partially degradable blends, 984–6
 - star-shaped copoly lactides, 983–4
- chitosan-poly(vinyl alcohol) blends, 986–7
- composting, 991–2, 993
 - environmental impact, 1019–23
 - incineration, 988–9
 - landfill, 987–8
 - pyrolysis, 989–90
 - recycling, 990–1, 992–1023
 - chemical, 1015–16
 - contamination, 1018–19
 - feedstock, 1010–15
 - mechanical, 1008–10
 - plastics, 994–8
 - preparation for, 1007–8
 - radiation, 1017–18
 - sorting, 998–1007
- Polynuclear aromatic hydrocarbons, 194
- Polyphenols, 429–34
- biodegradation, 459, 460, 491, 494, 495, 496
 - sources of, apple pomace, 587
- Potato waste, 707, 737–8
- Poultry waste *see* Meat waste
- Precautionary principle, 141
- Precipitation, 27, 395–6
- advantages/disadvantages, 506
 - dairy waste, 812–14
 - olive oil waste, 487–8
- President's Council on Sustainable Development, 42
- Prevention of pollution, 73
- Prion proteins, 782
- Prior informed consent procedure, 248, 251
- Proanthocyanidins, 431
- Process flow diagram, 47
- Project MELISSA, 716
- Proteins, 352
- Protocol for the Prevention of Pollution by Dumping from Ships and Aircraft, 215
- Pseudomonas putida*, 468
- Public perception, 70

- Pullulan, 418, 437–9
Pycnoporus coccineus, 467, 469
Pycnoporus cinnabarius, 707
 Pyrolysis
 advantages/disadvantages, 504
 analytical, 672
 cereal waste, 633, 634, 641, 646, 652, 653, 658, 660–75, 689, 690, 694
 flash, 667, 668
 fluidized bed furnace, 373, 473
 food waste, 351, 354, 371–3
 molten salt destruction, 373
 olive oil waste, 471, 497, 521
 olive press cake, 521, 524
 polymer waste, 989–90
 rotary kiln, 373
 wine waste, 416, 417, 425–6, 427
Pythium spp., 714
 Quality control, 70
 Quality management systems, 55
 Quercetin, 717
 Radioactive waste and substances, 190–2
 US legislation, 304–6
Ralstonia spp., 468
 Rapeseed oil, 727–8, 740, 744
 Rasar Convention, 225
 REACH system, 249, 252
 RECAL Programme, 964
 Record keeping, 81
 Recycling
 aluminum, 958–75
 RECAL Programme, 964
 food packaging, 944
 glass, 947
 environmental aspects, 955–8
 international situation, 951–2
 metals, 947
 newspaper, 946
 paper, 948, 975–80
 plastic, 946, 949
 polymer waste, 990–1, 992–1023
 chemical, 1015–16
 contamination, 1018–19
 feedstock, 1010–15
 mechanical, 1008–10
 plastics, 994–8
 preparation for, 1007–8
 radiation, 1017–18
 sorting, 998–1007
 vegetable waste, 705, 733
 Redcurrant by-products, 599
 Regulatory compliance, 68–9
 Requirement documents, 56
 Reregistration Eligibility Decision, 245
 Responsible Care program, 52, 290
 requirements of, 58
 Resveratrol, 8
 Reverse osmosis
 dairy waste, 809, 824
 food waste, 378
 olive oil waste, 481
Rhizoctonia solani, 515
Rhizopus oligosporus, 589
Rhizopus oryzae, 727
Rhodobacter sphaeroides, 526
 Rice, 630
 life cycle, 113, 115
 Rice waste, 651–8
 biogas, 654–5, 694
 combustion, 653, 654, 694
 composting, 651
 gasification, 655, 694
 pyrolysis, 652, 653, 694
 uses, 685–6
 Rio Declaration, 159
 Rio Earth Summit, 42, 159
 Risk control, 260–4
 Rotary kiln
 incineration, 371, 472
 pyrolysis, 373
 Rotating biological contactors, 776
 Rotating drum composting, 366
 Rotterdam Convention, 247, 251
 Rye, 631
Saccharomyces cerevisiae, 537, 871
Schizophyllum spp., 536
 Scientific Committee on Consumer Products, 147
 Scientific Committee on Emerging and Newly Identified Health Risks, 147
 Scientific Committee on Health and Environmental Risks, 147
Scopulariopsis brevicaulis, 585
Scytalidium acidophilum, 869
 Seafood industry

- inputs and outputs, 924–6
- LCA studies, 102, 113, 116, 862
- recirculating system, 880, 900–1
- Seafood waste, 861–937
 - treatment methods, 864–82, 883–905
 - advantages and disadvantages, 904–5
 - alkaline extraction, 903
 - anaerobic digestion, 872–4, 891–2
 - bioremediation, 867–72, 885
 - coagulation/flocculation, 879, 899–900
 - composting, 888–9, 917
 - fermentation, 885–8
 - filtration/screening, 874–5
 - hydrolysis, 865–7, 868, 883–5
 - membrane processes, 892–4
 - sedimentation, 902
 - uses, 882, 906–23
 - animal feed, 906–7, 918
 - biodiesel/biogas, 907–9, 918–19
 - fish oil production, 863, 876–8, 895–7
 - food industry/cosmetics, 911–16, 920–2
 - natural pigments, 909–11, 919–20
 - restructured fish products, 844, 879
 - waste management, 916, 922–3
- Sea level, 27
- Selenastrum capricornutum*, 12
- Self Diagnosis Method, 86
- Sequencing batch reactor
 - food waste, 346, 347, 349, 397–8
 - meat waste, 776
 - vegetable waste, 721
 - wine waste, 418–20
- Sequencing batch reactors, 10
- Shrimp waste, 742
- SimaPro 6 software, 116, 118–19
- Slag processing, 974
- Sludge digestion, 354–6, 364–5
- Slurry-phase bioremediation, 359
- Society for Environmental Toxicology and Chemistry (SETAC), 97
- Soil organic matter, 666
- Soil protection, 270–1
- Solar distillation *see* Distillation
- Solar dried citrus pulp, 580–1, 598
- Solar energy, 16
- Solidification, 659
- Solid-phase bioremediation, 359–60
 - landfarming, 359–60
- Solid-state fermentation
 - food waste, 350, 398–9
 - wine waste, 416
- Solubility-based processes, 1001–2
- Sorting of polymer waste, 998–1007
 - air tabling and triboelectric separation, 1004–5
 - cryo-comminution, 1006
 - Duales System, 999
 - electrostatic separation, 1007–8
 - flame treatment, 1006–7
 - floatability, 1002–4
 - fluorescence spectroscopy, 1000
 - hydrocyclone, 1001
 - macro-separation, 999
 - micro-separation, 999
 - optical recycling, 1000–1
 - OTTO system, 999
 - solubility-based processes, 1001–2
 - tracers, 1001
- SOSEA (Strategic Overview of Significant Environmental Aspects), 85
- Specific documents, 56
- Squid protein hydrolysate, 912–13
- Static pile composting, 365
- Steam stripping, 660
- Stilbenes, 587
- Stirred tank reactors, meat waste, 773
- Stockholm Convention on Persistent Organic Pollutants, 249–50
- Strategic Advisory Group for the Environment (SAGE), 43
- Strategies for Today's Environmental Partnership (STEP), 290
- Struvite, 813, 828
- Subcritical water extraction, 578, 579
- Sugar beet by-products, 590–4
 - in paper production, 591–2
 - pomace, 707
- Sugarcane bagasse, 705–6, 707
- Sulfur dioxide, 29, 194, 195, 196
- Sulfur hexafluoride, 171
- Sunflower oil, 605
- Supercritical fluid extraction, 577–8
- Supercritical water gasification, 677
- Suppliers, choice of, 69–70
- Surfactants, 6
- Suspended particulate matter, 29, 194

- Sustainable corporate performance, 122
- Sustainable development, 40, 42, 158–68,
324, 326, 943
framework, 159–60
instruments, 160–3
integration of environmental policy,
163–8
- Sustainable forest management, 239
- Sustainable Winegrowing New Zealand, 91
- Swedish EKO-Energi program, 89–90
- SWOT analysis, 86
- Taiwan Environmental Management
Association, 90
- Tanais dulongii*, 12
- Technical Committee 207, 43–5,
63, 68
- Tetramethylammonium hydroxide, 671
- Thermal energy use, 107
- Thermocalcic precipitation-microfiltration,
809, 810
- Thermogravimetric analyzers, 670
- Thermophilic anaerobic digestion
food waste, 346, 350, 392
wine waste, 417, 424
- Thiobacillus denitrificans*, 14
- Thiobacillus ferrooxidans*, 12
- Total dissolved solids, 8
- Total organic carbon, 485–6
- Total suspended solids, 5
- Toxicity/persistence units, 33
- Training, 77–8
- Trametes hirsuta*, 398, 399, 443
- Trametes versicolor*, 461
- Transesterification of vegetable oil waste,
726–7, 728–9, 733, 736, 750
- Triboelectric separation, 1004–5
- 1,1,1-Trichloroethane, 196
- Trichoderma* spp., 537, 714
- Trichoderma reesei*, 815
- Ultrafiltration
food waste, 378
olive oil waste, 481
- Ultrasound irradiation, food waste, 397
- United Nations
Brundtland Commission report, 158
Economic Commission for Europe, 20
Environment Programme (UNEP), 4
- Framework Convention on Climate
Change, 170–1, 194
- Intergovernmental Panel on Climate
Change, 25
- United States
American Petroleum Institute, 290
Environmental Protection Agency, 194,
289–90, 291
Federal Register, 290
legislation, 293–317
Air Pollution Control Act 1955, 290
Clean Air Act 1970, 296, 313–14
Clean Smokestacks Act 2002, 311–12,
317
Clean Water Act 1972, 297–9, 314
Climate Stewardship Act 2005, 312,
317
Coastal Zone Management Act 1972,
299, 314
Comprehensive Environmental
Response, Compensation and
Liability Act, 305, 316
Endangered Species Act 1973,
299–300
Environmental Management
Act, 317
Federal Facility Compliance Act 1992,
309, 317
Federal Insecticide, Fungicide and
Rodenticide Act 1947, 290, 293–4,
313
Hazardous Materials Transportation
Act 1974, 301–2, 315
Low Level Radioactive Policy Act
1980, 305, 316
Marine Protection, Research and
Sanctuaries Act 1972, 298, 314
National Environmental Policy Act
1969, 290, 294–5, 313
Nuclear Waste Policy Act, 310, 317
Occupational Safety and Health Act
1970, 295–6, 313
Oil Pollution Act 1990, 308, 316
Pollution Prevention Act 1990, 31, 308
Resource Conservation and Recovery
Act 1976, 302, 315
Rivers and Harbors Acts, 291
Safe Drinking Water Act, 300–1,
314–15

- Soil Conservation and Land Care Act
1989, 307
- Superfund Amendments and
Reauthorization Act 1986, 306, 316
- Surface Mining Control and
Reclamation Act 1977, 304, 315
- TAPPI standard UM 666
(Dispersibility Test for Adhesives),
976
- Toxic Substances Control Act, 303,
315
- Uranium Mill Tailings Radiation
Control Act 1978, 304–5, 315
- National Ambient Air Quality Standards,
296
- National Oil and Hazardous Substances
Pollution Contingency Plan, 308
- National Pollutant Discharge Elimination
System, 298
- Oil Spill Liability Trust Fund, 308
- Uranium Mill Tailings Remedial Action
Project, 305
- Voluntary Protection Programs, 296
- Upflow anaerobic sludge blanket reactor
dairy waste, 804–5, 821
paper waste, 978
seafood waste, 873
- Urban Waste Water Treatment Directive, 135
- USA, legislation, 289–341
- USES-LCA model, 121
- Valorization of seafood waste, 890
- Vaporization, 376
- Vegetable oil refining industry wastewater,
734
- Vegetable oil waste, 601, 605, 741, 742, 743,
748–9
biodiesel, 711, 725–9, 732
transesterification, 726–7, 728–9, 733,
736, 746, 749
- Vegetable pomace, 708
- Vegetable processing waste, 743–4
- Vegetable waste, 703–61
compounds in, 716–17
treatment methods, 704–13
anaerobic digestion, 709–10, 718–22,
731–3, 735–6, 738, 740–1, 749
biodegradation, 715–16, 746, 751
combustion, 734, 749
comparison of, 730–51
composting, 722–5, 735, 736, 738,
746–8, 749
dehydration, 745–6, 751
fluidized bed combustion, 717–18
recycling, 705, 733
uses
animal feeds, 705–7, 729–30
biodiesel, 709–10, 725–9, 732, 735
bioflavors, 707
energy recovery, 713, 739
feedstuffs, 705–7
nitrogen mineralization, 712–13
phytochemicals, 707
see also Fruit/fruit juice waste
- Vegetation waters, 526
- Vending machines, 123–4
- Veterinary antibiotics *see* Pharmaceuticals
- Vienna Convention for the Protection of the
Ozone Layer, 292–3
- Vinasse, 8
- Vitrification, 660
- Volatile fatty acids, 571, 709, 711
- Volatile organic compounds, 5, 196, 679
- Volatile solids, 711
- Waste Analysis Software Tool for
Environmental Decisions (WASTED) model,
945
- Waste classification, 136
- Waste electrical and electronic equipment,
185
- Waste management, 174, 176–92
chemical products, 264, 266–9
food waste, 345–410
hazardous waste, 189–90
incineration, 136, 137, 176, 185, 188–9
LCA studies, 104
olive oil waste, 453–568
radioactive waste and substances, 190–2
specific waste, 180, 183–5
wine waste, 413–52
- Waste recycling, 180
- Wastewater treatment, 4–6, 358, 662
anaerobic digestion, 422
distillation, 396–7
evaporators, 375–6
olive oil waste, 530–3, 546–7
see also Waste management

- Water Environment Federation, 4
- Water holding capacity, 513
- Watermelon by-products, 590, 600
 - datch, 608
- Water pollution, 10–11
- Water protection and management
 - discharges of substances, 220–3
 - European legislation, 206–23
 - general framework, 208–9
 - inland water, 220
 - marine pollution, 211–19
 - specific uses of water, 209–11
 - US legislation, 297–301
- Wet milling, 584
- Wet oxidation
 - food waste, 348, 351, 386–8
 - wine waste, 427–9
- Wheat, 630
- Wheat germ, roasting, 636
- Wheat lignin
 - fungal decay, 635
 - pyrolysis, 633, 634, 635
- Wheat straw waste
 - adsorption, 637
 - biodegradation, 638
 - combustion, 685
 - combustion, 635, 638
 - composting, 632, 637, 639
 - enzyme activity, 640
 - enzymic hydrolysis, 639
 - gasification, 636
 - irradiation, 640
 - pyrolysis, 633
- Whey concentrate, 842–3
- Wind energy, 17
- Windrow composting, 360, 364, 509
- Winemaking
 - by-products, 415
 - flow diagram, 414
- Wine waste, 7–8, 413–52
 - applications, 419
 - adsorbents, 439–44
 - compost fertilizer, 434–7
 - heavy metal adsorption, 418
 - constituents
 - polyphenols, 429–34
 - pullulan, 437–9
 - treatment
 - anaerobic digestion, 420–4
 - combustion, 416
 - composting, 415, 416, 417
 - electrodialysis, 416
 - incineration, 416, 424–5
 - ozonation, 426–7
 - pyrolysis, 416, 417, 425–6, 427
 - sequencing batch reactor, 418–20
 - solid-state fermentation, 416
 - supercritical fluid extraction, 477–8
 - thermophilic anaerobic digestion, 417, 424
 - wet oxidation, 427–9
- Wood pellets, 686
- World Trade Organization, 159
- Xanthan, 533–4
- Xanthomonas campestris*, 533–4
- Xylanase, 979
- Yarrowia lipolytica*, 462–3
- Zeolite bed filtration, 773–4
- Zero Emission Strategy, 1021

Food science and technology

International Series

- Maynard A. Amerine, Rose Marie Pangborn, and Edward B. Roessler, *Principles of Sensory Evaluation of Food*. 1965.
- Martin Glicksman, *Gum Technology in the Food Industry*. 1970.
- Maynard A. Joslyn, *Methods in Food Analysis*, second edition. 1970.
- C. R. Stumbo, *Thermobacteriology in Food Processing*, second edition. 1973.
- Aaron M. Altschul (ed.), *New Protein Foods: Volume 1, Technology, Part A*—1974. Volume 2, *Technology, Part B*—1976. Volume 3, *Animal Protein Supplies, Part A*—1978. Volume 4, *Animal Protein Supplies, Part B*—1981. Volume 5, *Seed Storage Proteins*—1985.
- S. A. Goldblith, L. Rey, and W. W. Rothmayr, *Freeze Drying and Advanced Food Technology*. 1975.
- R. B. Duckworth (ed.), *Water Relations of Food*. 1975.
- John A. Troller and J. H. B. Christian, *Water Activity and Food*. 1978.
- A. E. Bender, *Food Processing and Nutrition*. 1978.
- D. R. Osborne and P. Voogt, *The Analysis of Nutrients in Foods*. 1978.
- Marcel Loncin and R. L. Merson, *Food Engineering: Principles and Selected Applications*. 1979.
- J. G. Vaughan (ed.), *Food Microscopy*. 1979.
- J. R. A. Pollock (ed.), *Brewing Science*, Volume 1—1979. Volume 2—1980. Volume 3—1987.
- J. Christopher Bauernfeind (ed.), *Carotenoids as Colorants and Vitamin A Precursors: Technological and Nutritional Applications*. 1981.
- Pericles Markakis (ed.), *Anthocyanins as Food Colors*. 1982.
- George F. Stewart and Maynard A. Amerine (eds.), *Introduction to Food Science and Technology*, second edition. 1982.
- Malcolm C. Bourne, *Food Texture and Viscosity: Concept and Measurement*. 1982.
- Hector A. Iglesias and Jorge Chirife, *Handbook of Food Isotherms: Water Sorption Parameters for Food and Food Components*. 1982.
- Colin Dennis (ed.), *Post-Harvest Pathology of Fruits and Vegetables*. 1983.
- P. J. Barnes (ed.), *Lipids in Cereal Technology*. 1983.
- David Pimentel and Carl W. Hall (eds.), *Food and Energy Resources*. 1984.
- Joe M. Regenstein and Carrie E. Regenstein, *Food Protein Chemistry: An Introduction for Food Scientists*. 1984.
- Maximo C. Gacula, Jr., and Jagbir Singh, *Statistical Methods in Food and Consumer Research*. 1984.
- Fergus M. Clydesdale and Kathryn L. Wiemer (eds.), *Iron Fortification of Foods*. 1985.
- Robert V. Decareau, *Microwaves in the Food Processing Industry*. 1985.

- S. M. Herschdoerfer (ed.), *Quality Control in the Food Industry*, second edition. Volume 1—1985. Volume 2—1985. Volume 3—1986. Volume 4—1987.
- F. E. Cunningham and N. A. Cox (eds.), *Microbiology of Poultry Meat Products*. 1987.
- Walter M. Urbain, *Food Irradiation*. 1986.
- Peter J. Bechtel, *Muscle as Food*. 1986.
- H. W.-S. Chan, *Autoxidation of Unsaturated Lipids*. 1986.
- Chester O. McCorkle, Jr., *Economics of Food Processing in the United States*. 1987.
- Jethro Japtiani, Harvey T. Chan, Jr., and William S. Sakai, *Tropical Fruit Processing*. 1987.
- J. Solms, D. A. Booth, R. M. Dangborn, and O. Raunhardt, *Food Acceptance and Nutrition*. 1987.
- R. Macrae, *HPLC in Food Analysis*, second edition. 1988.
- A. M. Pearson and R. B. Young, *Muscle and Meat Biochemistry*. 1989.
- Marjorie P. Penfield and Ada Marie Campbell, *Experimental Food Science*, third edition. 1990.
- Leroy C. Blankenship, *Colonization Control of Human Bacterial Enteropathogens in Poultry*. 1991.
- Yeshajahu Pomeranz, *Functional Properties of Food Components*, second edition. 1991.
- Reginald H. Walter, *The Chemistry and Technology of Pectin*. 1991.
- Herbert Stone and Joel L. Sidel, *Sensory Evaluation Practices*, second edition. 1993.
- Robert L. Shewfelt and Stanley E. Prussia, *Postharvest Handling: A Systems Approach*. 1993.
- R. Paul Singh and Dennis R. Heldman, *Introduction to Food Engineering*, second edition. 1993.
- Tilak Nagodawithana and Gerald Reed, *Enzymes in Food Processing*, third edition. 1993.
- Dallas G. Hoover and Larry R. Steenson, *Bacteriocins*. 1993.
- Takayaki Shibamoto and Leonard Bjeldanes, *Introduction to Food Toxicology*. 1993.
- John A. Troller, *Sanitation in Food Processing*, second edition. 1993.
- Ronald S. Jackson, *Wine Science: Principles and Applications*. 1994.
- Harold D. Hafs and Robert G. Zimbelman, *Low-fat Meats*. 1994.
- Lance G. Phillips, Dana M. Whitehead, and John Kinsella, *Structure-Function Properties of Food Proteins*. 1994.
- Robert G. Jensen, *Handbook of Milk Composition*. 1995.
- Yrjö H. Roos, *Phase Transitions in Foods*. 1995.
- Reginald H. Walter, *Polysaccharide Dispersions*. 1997.
- Gustavo V. Barbosa-Cánovas, M. Marcela Góngora-Nieto, Usha R. Pothakamury, and Barry G. Swanson, *Preservation of Foods with Pulsed Electric Fields*. 1999.
- Ronald S. Jackson, *Wine Science: Principles, Practice, Perception*, second edition. 2000.
- R. Paul Singh and Dennis R. Heldman, *Introduction to Food Engineering*, third edition. 2001.
- Ronald S. Jackson, *Wine Tasting: A Professional Handbook*. 2002.
- Malcolm C. Bourne, *Food Texture and Viscosity: Concept and Measurement*, second edition. 2002.
- Benjamin Caballero and Barry M. Popkin (eds), *The Nutrition Transition: Diet and Disease in the Developing World*. 2002.
- Dean O. Cliver and Hans P. Riemann (eds), *Foodborne Diseases, second edition*. 2002.
- Martin Kohlmeier, *Nutrient Metabolism*, 2003.
- Herbert Stone and Joel L. Sidel, *Sensory Evaluation Practices*, third edition. 2004.
- Jung H. Han, *Innovations in Food Packaging*. 2005.
- Da-Wen Sun, *Emerging Technologies for Food Processing*. 2005.
- Hans Riemann and Dean Cliver (eds) *Foodborne Infections and Intoxications*, third edition. 2006.

- Ioannis S. Arvanitoyannis, *Waste Management for the Food Industries*. 2008.
- Ronald S. Jackson, *Wine Science: Principles and Applications*, third edition. 2008.
- Da-Wen Sun, *Computer Vision Technology for Food Quality Evaluation*. 2008.
- Kenneth David, *What Can Nanotechnology Learn From Biotechnology?* 2008.
- Elke Arendt, *Gluten-Free Cereal Products and Beverages*. 2008.