

NEW AGE

THIRD EDITION

# CAD/CAM/CIM



**P. RADHAKRISHNAN**  
**S. SUBRAMANYAN**  
**V. RAJU**



NEW AGE INTERNATIONAL PUBLISHERS

# **CAD/CAM/CIM**

**(THIRD EDITION)**

**This page  
intentionally left  
blank**

# **CAD/CAM/CIM**

**(THIRD EDITION)**

**P. RADHAKRISHNAN**

Vice Chancellor  
VIT University, Vellore  
Tamil Nadu

**S. SUBRAMANYAN**

Former Principal  
PSG College of Technology, Coimbatore  
&  
Former Vice Chancellor  
Bharathiar University, Coimbatore  
Tamil Nadu

**V. RAJU**

Dean  
School of Engineering Technologies  
Farmingdale State University  
New York



PUBLISHING FOR ONE WORLD

**NEW AGE INTERNATIONAL (P) LIMITED, PUBLISHERS**

New Delhi • Bangalore • Chennai • Cochin • Guwahati • Hyderabad  
Jalandhar • Kolkata • Lucknow • Mumbai • Ranchi

Visit us at [www.newagepublishers.com](http://www.newagepublishers.com)

Copyright © 2008, 2000, 1994, New Age International (P) Ltd., Publishers  
Published by New Age International (P) Ltd., Publishers

---

All rights reserved.

No part of this ebook may be reproduced in any form, by photostat, microfilm, xerography, or any other means, or incorporated into any information retrieval system, electronic or mechanical, without the written permission of the publisher.  
*All inquiries should be emailed to [rights@newagepublishers.com](mailto:rights@newagepublishers.com)*

**ISBN (13) : 978-81-224-2711-0**

**PUBLISHING FOR ONE WORLD**

**NEW AGE INTERNATIONAL (P) LIMITED, PUBLISHERS**

4835/24, Ansari Road, Daryaganj, New Delhi - 110002

Visit us at [www.newagepublishers.com](http://www.newagepublishers.com)

---

# **PREFACE**

Manufacturing managers and engineers are ever concerned with improvement in quality, reduction in both manufacturing cost and delivery time. The globalization of economy requires introduction of new products with enhanced features at competitive costs. Another challenge is the reduction in product life span. This necessitates considerable time compression in product development cycle. Yet another significant trend is mass customization which calls for extreme flexibility in manufacturing. The massive outsourcing in manufacturing is another important development in recent years.

The new edition of CAD/CAM/CIM has been brought out to focus on the response of CIM technology to address to these challenges. Manufacturing in the new millennium is moving towards more and more sophistication in exploiting the capabilities of computer hardware and software. Robust design methodologies and integration of shape design and functional design are included in the present edition. Optimized manufacturing is a possibility now with the extensive use of FEA. Apart from design optimization, FEA is used to model and simulate complex manufacturing processes to evolve several iterations. This enables engineers to make right parts first time every time. An additional chapter on simulation softwares has been added in the present edition to introduce this powerful tool to the students.

The authors would like to acknowledge the contribution of our erstwhile colleagues in the PSG CAD/CAM Centre as well as Krishnaveni and Sasikala in word processing the earlier editions and Govindaswamy for helping with some chapters in the present edition. Acknowledgements are due to K.J. Reddy for providing some models for reproduction in this edition and to Pradeep for critical suggestions. The excellent support and encouragement extended by Padmini, Anitha and Hari during the revision of this edition is gratefully acknowledged.

**P. Radhakrishnan  
S. Subramanian  
V. Raju**

**This page  
intentionally left  
blank**

---

# CONTENTS

---

*PREFACE* (v)

---

## **1. COMPUTER INTEGRATED MANUFACTURING** **1**

<i>1.1 INTRODUCTION</i>	<i>1</i>
<i>1.2 TYPES OF MANUFACTURING</i>	<i>3</i>
<i>1.3 EVOLUTION OF COMPUTER INTEGRATED MANUFACTURING</i>	<i>4</i>
<i>1.4 CIM HARDWARE AND CIM SOFTWARE</i>	<i>6</i>
<i>1.5 NATURE AND ROLE OF THE ELEMENTS OF CIM SYSTEM</i>	<i>7</i>
<i>1.6 DEVELOPMENT OF CIM</i>	<i>10</i>

---

## **2. PRODUCT DEVELOPMENT THROUGH CIM** **13**

<i>2.1 INTRODUCTION</i>	<i>13</i>
<i>2.2 PRODUCT DEVELOPMENT CYCLE</i>	<i>13</i>
<i>2.3 SEQUENTIAL ENGINEERING</i>	<i>16</i>
<i>2.4 CONCURRENT ENGINEERING</i>	<i>18</i>
<i>2.5 COMPARISON OF CONCURRENT ENGINEERING AND SEQUENTIAL ENGINEERING</i>	<i>19</i>
<i>2.6 IMPLEMENTATION OF CONCURRENT ENGINEERING</i>	<i>21</i>
<i>2.7 CONCURRENT ENGINEERING AND INFORMATION TECHNOLOGY</i>	<i>23</i>
<i>2.8 SOFT AND HARD PROTOTYPING</i>	<i>25</i>
<i>2.9 CHARACTERISTICS OF CONCURRENT ENGINEERING</i>	<i>25</i>
<i>2.10 KEY FACTORS INFLUENCING THE SUCCESS OF CE</i>	<i>26</i>
<i>2.11 EXAMPLE OF CONCURRENT ENGINEERING</i>	<i>26</i>
<i>2.12 TECHNIQUES TO IMPROVE MANUFACTURABILITY AND REDUCE LEAD TIME</i>	<i>27</i>
<i>2.13 IMPROVING THE DESIGN</i>	<i>32</i>
<i>2.14 TAGUCHI METHOD FOR ROBUST DESIGN</i>	<i>34</i>
<i>2.15 VALUE ENGINEERING</i>	<i>34</i>
<i>2.16 PRODUCT LIFE CYCLE MANAGEMENT</i>	<i>35</i>



---

<b>3. PRINCIPLES OF COMPUTER GRAPHICS</b>	<b>41</b>
3.1 INTRODUCTION	41
3.2 GRAPHIC PRIMITIVES	42
3.3 POINT PLOTTING	43
3.4 DRAWING OF LINES	43
3.5 BRESENHAM'S CIRCLE ALGORITHM	47
3.6 ELLIPSE	55
3.7 TRANSFORMATION IN GRAPHICS	55
3.8 CO-ORDINATE SYSTEMS USED IN GRAPHICS AND WINDOWING	55
3.9 VIEW PORT	56
3.10 2-D TRANSFORMATIONS	56
3.11 HOMOGENEOUS TRANSFORMATIONS	60
3.12 COMBINATION TRANSFORMATIONS	61
3.13 CLIPPING	63
3.14 3-DIMENSIONAL TRANSFORMATIONS	63
3.15 PROJECTIONS	64
3.16 SCAN CONVERSION	66
3.17 RENDERING	69
3.18 RASTERIZING POLYGONS	69
3.19 HIDDEN SURFACE REMOVAL	70
3.20 ANTI ALIASING	72
3.21 REFLECTION	73
3.22 SHADING	75
3.23 GENERATION OF CHARACTERS	76
<b>4. COMPUTER HARDWARE</b>	<b>77</b>
4.1 INTRODUCTION	77
4.2 COMPUTER FUNDAMENTALS	78
4.3 CLASSIFICATION OF COMPUTERS	79
4.4 DATA COMMUNICATIONS	83
4.5 DESIGN WORK STATIONS	89
4.6 ARCHITECTURE OF A TYPICAL GRAPHICS WORKSTATION	90
4.7 INTERACTIVE DISPLAY DEVICES	93
4.8 INPUT DEVICES	97
4.9 OUTPUT DEVICES	100
<b>5. OPERATING SYSTEMS AND ENVIRONMENTS</b>	<b>103</b>
5.1 INTRODUCTION	103
5.2 OPERATING SYSTEM (OS)	104
5.3 COMPARISON OF COMMANDS IN POPULAR OPERATING SYSTEMS	106
5.4 UNIX - OPERATING SYSTEM	108
5.5 ARCHITECTURE OF UNIX SYSTEM	109

5.6 GRAPHICAL USER INTERFACES (WINDOWS ENVIRONMENT)	113
5.7 MS WINDOWS	114
5.8 WINDOWS NT	115
5.9 LINUX	120

## **6. GEOMETRIC MODELING TECHNIQUES** **121**

6.1 INTRODUCTION	121
6.2 GEOMETRIC MODELING	123
6.3 SALIENT FEATURES OF SOLID MODELING	128
6.4 COMMAND, MENU AND ICON DRIVEN SOFTWARES	136
6.5 FEATURES OF A DRAFTING PACKAGE	138
6.6 DRAWING UTILITIES	139
6.7 ENTITIES	142
6.8 EDIT COMMANDS	143
6.9 BLOCKS AND SYMBOLS	143
6.10 DISPLAY	144
6.11 CROSS HATCHING AND PATTERN FILLING	144
6.12 DIMENSIONING	145
6.13 ENQUIRY COMMANDS	146
6.14 3-D DRAWINGS	147
6.15 PLOTTING A DRAWING	149
6.16 CONFIGURING THE DRAFTING SOFTWARE	149
6.17 CUSTOMISATION	149
6.18 DRAWING INTERCHANGE FILES	150
6.19 DRAWING OFFICE MANAGEMENT	150
6.20 SURFACE MODELING	152
6.21 REPRESENTATION OF CURVES AND SURFACES	154
6.22 DESIGN OF CURVED SHAPES	155
6.23 CUBIC SPLINES	156
6.24 BEZIER CURVES	159
6.25 B-SPLINES	161
6.26 NURBS AND B-SPLINES	162
6.27 REPRESENTATION OF SURFACES	163
6.28 DESIGN OF SURFACES	163
6.29 PARAMETRIC DESIGN OF SURFACES	163
6.30 BICUBIC POLYNOMIAL SURFACE PATCHES	164
6.31 BEZIER BICUBIC SURFACE PATCHES	165
6.32 CUBIC B-SPLINE SURFACES	166
6.33 SURFACE MODELING IN COMMERCIAL DRAFTING AND MODELING SOFTWARE	166
6.34 THE CONCEPTUAL DESIGN PROCESS	174
6.35 SKETCHING THE GEOMETRY	176
6.36 UNDERSTANDING CURVE AND SURFACE DESIGN	177
6.37 OTHER FEATURES USEFUL FOR CONCEPTUAL DESIGN	185
6.38 DATA TRANSFER TO OTHER SOFTWARES	185

---

<b>7. FINITE ELEMENT MODELING AND ANALYSIS IN CIM</b>	<b>189</b>
7.1 INTRODUCTION	189
7.2 GENERAL STEPS INVOLVED IN FINITE ELEMENT ANALYSIS	191
7.3 TYPES OF ANALYSIS	193
7.4 DEGREES OF FREEDOM	195
7.5 INFLUENCE COEFFICIENTS	196
7.6 ELEMENT AND STRUCTURE STIFFNESS EQUATIONS	196
7.7 ASSEMBLY OF ELEMENTS	212
7.8 FINITE ELEMENT ANALYSIS PACKAGES	215
7.9 GENERAL STRUCTURE OF A FINITE ELEMENT ANALYSIS PROCEDURE	216
7.10 ARCHITECTURE OF FINITE ELEMENT SOFTWARE	221
7.11 USING A FINITE ELEMENT ANALYSIS PACKAGE FOR SIMPLE PROBLEMS	222
7.12 ELEMENTS IN A FINITE ELEMENT ANALYSIS SOFTWARE	223
7.13 EXAMPLES OF SOLUTION USING A SOFTWARE	228
7.14 MANUFACTURING APPLICATIONS	242
7.15 WELDING SIMULATION	243
7.16 FINITE ELEMENT ANALYSIS APPLICATIONS TO METAL FORMING	244
7.17 SIMULATION OF HEAT TREATMENT	245
7.18 PLASTIC INJECTION MOLDING	245
<b>8. CIM DATA BASE AND DATA BASE MANAGEMENT SYSTEMS</b>	<b>247</b>
8.1 INTRODUCTION	247
8.2 DATABASE REQUIREMENTS OF CIM	249
8.3 DATA BASE	249
8.4 DATABASE MANAGEMENT	251
8.5 FEATURES OF A DATABASE MANAGEMENT SYSTEM	251
8.6 DATABASE MODELS	252
8.7 DBMS ARCHITECTURE	255
8.8 QUERY LANGUAGE	255
8.9 STRUCTURED QUERY LANGUAGE [SQL]	256
8.10 SQL AS A KNOWLEDGE BASE QUERY LANGUAGE	257
8.11 PRODUCT DATA MANAGEMENT (PDM)	258
8.12 ADVANTAGES OF PDM	260
<b>9. COMPUTER AIDED PROCESS PLANNING</b>	<b>263</b>
9.1 INTRODUCTION	263
9.2 PROCESS PLANNING	263
9.3 STRUCTURE OF A PROCESS PLANNING SOFTWARE	266
9.4 INFORMATION REQUIRED FOR PROCESS PLANNING	266
9.5 OPERATION OF A TYPICAL COMPUTER AIDED PROCESS PLANNING SOFTWARE	267
9.6 CAD BASED PROCESS PLANNING - CERTAIN LIMITATIONS AND PROBLEMS	270
9.7 GROUP TECHNOLOGY	272

9.8 CODING STRUCTURES	274
9.9 OPITZ CLASSIFICATION SYSTEM	275
9.10 THE MICLASS SYSTEM	277
9.11 THE CODE SYSTEM	277
9.12 BENEFITS OF GROUP TECHNOLOGY	277
9.13 PROCESS SELECTION	279
9.14 EXPERIENCE-BASED PLANNING	279
9.15 HAND BOOKS/DATA BOOKS/MANUALS	280
9.16 DECISION TABLES AND DECISION TREES	280
9.17 PROCESS CAPABILITY	280
9.18 METHODS OF COMPUTER AIDED PROCESS PLANNING	282
9.19 VARIANT PROCESS PLANNING	282
9.20 GENERATIVE PROCESS PLANNING	284
9.21 IMPLEMENTATION CONSIDERATIONS	288
9.22 PROCESS PLANNING SYSTEMS	289

## **10. PLANNING OF RESOURCES FOR MANUFACTURING THROUGH INFORMATION SYSTEMS 293**

10.1 INTRODUCTION	293
10.2 BACKGROUND	294
10.3 ROLE OF MRP-II IN A CIM SYSTEM	295
10.4 MAJOR MODULES OF A MANUFACTURING RESOURCES PLANNING (MRP) SOFTWARE	296
10.5 MANUFACTURING APPLICATIONS	296
10.6 ENGINEERING APPLICATIONS	304
10.7 FINANCIAL APPLICATIONS	307
10.8 MARKETING APPLICATIONS	311
10.9 MISCELLANEOUS APPLICATIONS	313
10.10 COMMON ACRONYMS USED IN AN MRP-II ENVIRONMENT	314
10.11 STATUS OF MRP-II SOFTWARE	314
10.12 DYNAMIC ENTERPRISES	315
10.13 ENTERPRISE RESOURCE PLANNING (ERP)	316
10.14 SUPPLY CHAIN MANAGEMENT	320
10.15 VIRTUAL MANUFACTURING	322
10.16 SELECTION OF AN ERP PACKAGE	322
10.17 ERP IN INDIA	323
10.18 DYNAMIC ENTERPRISE MODELLING (DEM)	323

## **11. MANUFACTURING AUTOMATION 327**

11.1 INTRODUCTION	327
11.2 TYPES OF AUTOMATION SYSTEMS	328
11.3 PROGRAMMABLE LOGIC CONTROLLERS	329
11.4 PARTS OF A TYPICAL PLC SYSTEM	332
11.5 OPERATION OF A PLC	333

11.6 PROGRAMMING OF PLC	333
11.7 EXAMPLE OF APPLICATION OF PLC IN A CNC MACHINE	335
11.8 FACTORY LEVEL CONTROL	338
<hr/>	
<b>12. CNC MACHINE TOOLS</b>	<b>341</b>
12.1 INTRODUCTION	341
12.2 PRINCIPLE OF OPERATION OF A NUMERICAL CONTROLLED MACHINE	342
12.3 HISTORICAL DEVELOPMENT	351
12.4 TYPES OF CNC MACHINES	353
12.5 FEATURES OF CNC SYSTEMS	373
12.6 DIRECT NUMERICAL CONTROL (DNC)	379
12.7 FUNCTIONS AVAILABLE IN A TYPICAL CNC SYSTEM	384
12.8 STANDARD CONTROLLERS	386
12.9 SOME OF THE FEATURES AVAILABLE IN TYPICAL HIGH END CNC SYSTEM	387
12.10 GENERAL PROGRAMMING FEATURES OF CNC SYSTEMS	389
12.11 PROGRAMMING OF CNC MACHINE TOOLS	403
12.12 HINTS FOR PROGRAMMING	414
12.13 EXAMPLE OF PROGRAMMING A VERTICAL MACHINING CENTRE	423
12.14 CNC TURNING A GEAR BLANK	431
12.15 CNC TURNING A CASTING	442
12.16 CNC PROGRAM DEVELOPMENT AND VIRTUAL MACHINING USING CAM TECHNOLOGY	451
12.17 TECHNOLOGY OF CAM	454
12.18 PROCEDURE OF CAM	455
12.19 MANUFACTURING OPERATIONS	459
12.20 TOOL MOTION PARAMETERS	462
12.21 AUXILIARY NC SEQUENCES	463
12.22 CL DATA FILES	463
12.23 NC POST-PROCESSING	464
12.24 VIRTUAL MACHINING	464
12.25 SUMMARY	465
<hr/>	
<b>13. ROBOTS IN COMPUTER INTEGRATED MANUFACTURING</b>	<b>471</b>
13.1 INTRODUCTION	471
13.2 DEFINITION OF A ROBOT	472
13.3 TYPES OF ROBOTS	474
13.4 PERFORMANCE CAPABILITIES	481
13.5 PROGRAMMING ROBOTS	484
13.6 GEOMETRIC REQUIREMENTS FOR THE CAD/ROBOT LINKAGE	493
13.7 SIMULATION	494
13.8 ADAPTIVE CONTROL	494
13.9 ROBOT OPERATION	495

13.10 ENDS-OF-ARM-TOOLING	496
13.11 CONTROL SYSTEM OPERATION	496
13.12 APPLICATIONS OF INDUSTRIAL ROBOTS	496
13.13 THE INTEGRATION OF THE INDUSTRIAL ROBOT INTO A CIM SYSTEM	500
13.14 PRESENTATION OF WORK TO ROBOTS	501
13.15 PRODUCT DESIGN FOR AUTOMATIC MANUFACTURE BY ROBOTS	501
13.16 MANUFACTURERS OF ROBOTS	502

**14. COMPUTER AIDED QUALITY CONTROL 505**

14.1 INTRODUCTION	505
14.2 TOTAL QUALITY MANAGEMENT (TQM)	506
14.3 QC AND CIM	507
14.4 INSPECTION AND TESTING	508
14.5 STATISTICAL PROCESS CONTROL (SPC)	509
14.6 OBJECTIVES OF CAQC	509
14.7 ROLE OF COMPUTER IN QC	509
14.8 COORDINATE MEASURING MACHINE	510
14.9 NON-CONTACT INSPECTION METHODS	512
14.10 POST PROCESS METROLOGY	516
14.11 COMPUTER AIDED INSPECTION USING ROBOTS	517
14.12 INTEGRATED COMPUTER AIDED INSPECTION SYSTEMS	518
14.13 FLEXIBLE INSPECTION SYSTEM (FIS)	520

**15. FUNDAMENTALS OF NETWORKING 523**

15.1 INTRODUCTION	523
15.2 PRINCIPLES OF NETWORKING	523
15.3 NETWORK TECHNIQUES	526
15.4 LOCAL AREA NETWORK (LAN)	526
15.5 COMPONENTS OF A SMALL LOCAL AREA NETWORK	528
15.6 NETWORK WIRING METHODS	529
15.7 NETWORK INTERFACE CARDS	532
15.8 NETWORKING STANDARDS AND THEIR DEVELOPMENT	533
15.9 EXAMPLES OF NETWORK STANDARDS	536
15.10 ETHERNET	537
15.11 ISSUES IN INTER-SYSTEM COMMUNICATION	538
15.12 NETWORK OPERATING SYSTEMS	540
15.13 SYSTEM SECURITY	541
15.14 MANAGING REMOTE SYSTEMS IN A NETWORK	541
15.15 DESIGN ACTIVITY IN A NETWORKED ENVIRONMENT	542
15.16 ENGINEERING CHANGE CONTROL	542
15.17 NETWORKING IN A MANUFACTURING COMPANY	542
15.18 NETWORK FILE SYSTEM (NFS)	543

---

15.19 INTERNET	548
15.20 HARDWARE ELEMENTS OF A NETWORK	551
15.21 ATM (ASYNCHRONOUS TRANSFER MODE) NETWORKS	554
15.22 ENTERPRISE WIDE NETWORK	555
15.23 DOCUMENT AND WORKFLOW MANAGEMENT SYSTEM	557
15.24 A CASE STUDY OF APPLICATION OF GLOBAL NETWORKING	562
<b>16. COLLABORATIVE ENGINEERING</b>	<b>565</b>
16.1 INTRODUCTION	565
16.2 FASTER DESIGN THROUGHPUT	566
16.3 WEB BASED DESIGN	567
16.4 CHANGING DESIGN APPROACHES	568
16.5 EXTENDED ENTERPRISES	571
16.6 SOFTWARE FOR COLLABORATIVE DESIGN AND ENTERPRISE-WIDE PRODUCT VISUALIZATION	572
<b>17. GRAPHIC STANDARDS</b>	<b>575</b>
17.1 INTRODUCTION	575
17.2 STANDARDS FOR GRAPHICS PROGRAMMING	576
17.3 FEATURES OF GKS	576
17.4 OTHER GRAPHICS STANDARDS	578
17.5 PHIGS	578
17.6 OPENGL	580
17.7 PARASOLID	581
17.8 ACIS	583
17.9 EXCHANGE OF CAD DATA BETWEEN SOFTWARE PACKAGES	584
17.10 DXF FILES	585
17.11 INITIAL GRAPHICS EXCHANGE SPECIFICATION (IGES) GRAPHICS STANDARD	587
17.12 PRODUCT DATA EXCHANGE SPECIFICATION (PDES)	590
17.13 OTHER DATA EXCHANGE FORMATS	590
17.1.4 PRODUCT DATA TECHNOLOGY SUPPORT FOR COMPUTER AIDED CONCURRENT ENGINEERING	590
<b>18. CIM MODELS</b>	<b>597</b>
18.1 INTRODUCTION	597
18.2 ESPRIT - CIM OSA MODEL	599
18.3 THE NIST - AMRF HIERARCHICAL MODEL	601
18.4 THE SIEMENS MODEL OF CIM	602
18.5 THE CIM MODEL OF DIGITAL EQUIPMENT CORPORATION	603
18.6 THE IBM CONCEPT OF CIM	604
18.7 PRESENT SCENARIO	607

---

<b>19. FLEXIBLE MANUFACTURING SYSTEMS</b>	<b>609</b>
19.1 INTRODUCTION	609
19.2 SUBSYSTEMS OF FMS	610
19.3 SCOPE OF FMS	611
19.4 FMS COMPARED TO OTHER TYPES OF MANUFACTURING APPROACHES	611
19.5 TYPES OF FMS	612
19.6 BENEFITS OF FMS	620
19.7 MAJOR ELEMENTS OF FMS	622
19.8 OPTIMISATION OF FMS	627
19.9 OPERATIONAL ELEMENTS OF A TYPICAL FLEXIBLE MANUFACTURING CELL	628
19.10 TYPICAL FMS LAYOUT	638
19.11 FMS DEVELOPMENT IN INDIA	639
<b>20. SHOP FLOOR DATA COLLECTION SYSTEMS</b>	<b>641</b>
20.1 INTRODUCTION	641
20.2 SHOP FLOOR CONTROL	643
20.3 SHOP FLOOR DATA COLLECTION	646
20.4 TYPES OF DATA COLLECTION SYSTEMS	646
20.5 DATA INPUT TECHNIQUES	647
20.6 AUTOMATIC DATA COLLECTION SYSTEM	648
20.7 BAR CODE TECHNOLOGY	648
20.8 OPTICAL CHARACTER RECOGNITION	650
20.9 MAGNETIC INK CHARACTER RECOGNITION	651
20.10 VOICE RECOGNITION	651
20.11 SMART CARDS	651
20.12 DATA ACQUISITION SYSTEMS (DAS)	652
<b>21. SIMULATION IN MANUFACTURING</b>	<b>653</b>
21.1 INTRODUCTION	653
21.2 TYPES OF SIMULATION	654
21.3 TECHNIQUES OF SIMULATION	655
21.4 SIMULATION PROCESS FOR MANUFACTURING SYSTEMS ANALYSIS	656
21.5 SIMULATION SOFTWARE PACKAGES	656
21.6 APPLICATION OF SIMULATION	657
21.7 PROCEDURE FOR SIMULATION USING SOFTWARE	659
<b>INDEX</b>	<b>667</b>

---



**This page  
intentionally left  
blank**

# COMPUTER INTEGRATED MANUFACTURING

*An overview of CIM is presented in this chapter. A brief account of the evolution of CIM is included. The major functions carried out in a manufacturing plant are surveyed and the different levels of integration are identified.*

## 1.1 INTRODUCTION

Computer Integrated Manufacturing (CIM) encompasses the entire range of product development and manufacturing activities with all the functions being carried out with the help of dedicated software packages. The data required for various functions are passed from one application software to another in a seamless manner. For example, the product data is created during design. This data has to be transferred from the modeling software to manufacturing software without any loss of data. CIM uses a common database wherever feasible and communication technologies to integrate design, manufacturing and associated business functions that combine the automated segments of a factory or a manufacturing facility. CIM reduces the human component of manufacturing and thereby relieves the process of its slow, expensive and error-prone component. CIM stands for a holistic and methodological approach to the activities of the manufacturing enterprise in order to achieve vast improvement in its performance.

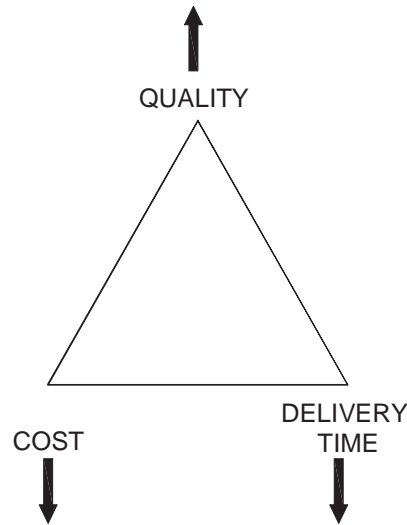
This methodological approach is applied to all activities from the design of the product to customer support in an integrated way, using various methods, means and techniques in order to achieve production improvement, cost reduction, fulfillment of scheduled delivery dates, quality improvement and total flexibility in the manufacturing system. CIM requires all those associated with a company to involve totally in the process of product development and manufacture. In such a holistic approach, economic, social and human aspects have the same importance as technical aspects.

CIM also encompasses the whole lot of enabling technologies including total quality management, business process reengineering, concurrent engineering, workflow automation, enterprise resource planning and flexible manufacturing.

A distinct feature of manufacturing today is mass customization. This implies that though the products are manufactured in large quantities, products must incorporate

customer-specific changes to satisfy the diverse requirements of the customers. This requires extremely high flexibility in the manufacturing system.

The challenge before the manufacturing engineers is illustrated in Fig.1.1.



**Fig.1.1 Challenges in Manufacturing**

Manufacturing industries strive to reduce the cost of the product continuously to remain competitive in the face of global competition. In addition, there is the need to improve the quality and performance levels on a continuing basis. Another important requirement is on time delivery. In the context of global outsourcing and long supply chains cutting across several international borders, the task of continuously reducing delivery times is really an arduous task. CIM has several software tools to address the above needs.

Manufacturing engineers are required to achieve the following objectives to be competitive in a global context.

- Reduction in inventory
- Lower the cost of the product
- Reduce waste
- Improve quality
- Increase flexibility in manufacturing to achieve immediate and rapid response to:
  - Product changes
  - Production changes
  - Process change
  - Equipment change
  - Change of personnel

CIM technology is an enabling technology to meet the above challenges to the manufacturing.

The advances in automation have enabled industries to develop islands of automation. Examples are flexible manufacturing cells, robotized work cells, flexible inspection cells etc. One of the objectives of CIM is to achieve the consolidation and integration of these islands of automation. This requires sharing of information among different applications or sections of a factory, accessing incompatible and heterogeneous data and devices. The ultimate objective is to meet the competition by improved customer satisfaction through reduction in cost, improvement in quality and reduction in product development time.

CIM makes full use of the capabilities of the digital computer to improve manufacturing. Two of them are:

- i. Variable and Programmable automation
- ii. Real time optimization

The computer has the capability to accomplish the above for hardware components of manufacturing (the manufacturing machinery and equipment) and software component of manufacturing (the application software, the information flow, database and so on).

The capabilities of the computer are thus exploited not only for the various bits and pieces of manufacturing activity but also for the entire system of manufacturing. Computers have the tremendous potential needed to integrate the entire manufacturing system and thereby evolve the computer integrated manufacturing system.

## 1.2 TYPES OF MANUFACTURING

The term “manufacturing” covers a broad spectrum of activities. Metal working industries, process industries like chemical plants, oil refineries, food processing industries, electronic industries making microelectronic components, printed circuit boards, computers and entertainment electronic products etc. are examples of manufacturing industries. Manufacturing involves fabrication, assembly and testing in a majority of situations. However, in process industries operations are of a different nature.

Manufacturing industries can be grouped into four categories:

### **i. Continuous Process Industries**

In this type of industry, the production process generally follows a specific sequence. These industries can be easily automated and computers are widely used for process monitoring, control and optimization. Oil refineries, chemical plants, food processing industries, etc are examples of continuous process industries.

### **ii. Mass Production Industries**

Industries manufacturing fasteners (nuts, bolts etc.), integrated chips, automobiles, entertainment electronic products, bicycles, bearings etc. which are all mass produced can be classified as mass production industries. Production lines are specially designed and optimized to ensure automatic and cost effective operation. Automation can be either fixed type or flexible.

### iii. Batch Production (Discrete Manufacturing)

The largest percentage of manufacturing industries can be classified as batch production industries. The distinguishing features of this type of manufacture are the small to medium size of the batch, and varieties of such products to be taken up in a single shop. Due to the variety of components handled, work centres should have broader specifications. Another important fact is that small batch size involves loss of production time associated with product changeover.

As mentioned earlier, integration of computer in process industries for production automation, process monitoring and control and optimization is relatively easy. In the case of mass production and batch production computer integration faces a number of problems as there are a large number of support activities which are to be tied together. These are discussed in detail later in this chapter.

Automation of manufacture has been implemented using different techniques since the turn of the 20th Century. Fixed automation is the first type to emerge. Single spindle automatic lathe, multi spindle automatic lathe and transfer lines are examples of fixed automation. Fixed automation using mechanical, electrical, pneumatic and hydraulic systems is widely used in automobile manufacturing. This type of automation has a severe limitation - these are designed for a particular product and any product change will require extensive modifications to the automation system.

The concept of programmable automation was introduced later. These were electrically controlled systems and programs were stored in punched cards and punched tapes. Typical examples of programmable automation are:

- i. Electrical programme controlled milling machines
- ii. Hydraulically operated Automatic lathes with programmable control drum
- iii. Sequencing machines with punched card control /plug board control

Development of digital computers, microelectronics and microprocessors significantly altered the automation scenario during 1950-1990. Machine control systems are now designed around microprocessors and microelectronics is part and parcel of industrial drives and control. The significant advances in miniaturization through integration of large number of components into small integrated chips and the consequent improvement in reliability and performance have increased the popularity of microelectronics. This has resulted in the availability of high performance desktop computing machines as well as file servers which can be used for industrial control with the help of application software packages.

## 1.3 EVOLUTION OF COMPUTER INTEGRATED MANUFACTURING

Computer Integrated Manufacturing (CIM) is considered a natural evolution of the technology of CAD/CAM which by itself evolved by the integration of CAD and CAM. Massachusetts Institute of Technology (MIT, USA) is credited with pioneering the

development in both CAD and CAM. The need to meet the design and manufacturing requirements of aerospace industries after the Second World War necessitated the development these technologies. The manufacturing technology available during late 40's and early 50's could not meet the design and manufacturing challenges arising out of the need to develop sophisticated aircraft and satellite launch vehicles. This prompted the US Air Force to approach MIT to develop suitable control systems, drives and programming techniques for machine tools using electronic control.

The first major innovation in machine control is the Numerical Control (NC), demonstrated at MIT in 1952. Early Numerical Control Systems were all basically hardwired systems, since these were built with discrete systems or with later first generation integrated chips. Early NC machines used paper tape as an input medium. Every NC machine was fitted with a tape reader to read paper tape and transfer the program to the memory of the machine tool block by block. Mainframe computers were used to control a group of NC machines by mid 60's. This arrangement was then called Direct Numerical Control (DNC) as the computer bypassed the tape reader to transfer the program data to the machine controller. By late 60's mini computers were being commonly used to control NC machines. At this stage NC became truly soft wired with the facilities of mass program storage, off-line editing and software logic control and processing. This development is called Computer Numerical Control (CNC).

Since 70's, numerical controllers are being designed around microprocessors, resulting in compact CNC systems. A further development to this technology is the distributed numerical control (also called DNC) in which processing of NC program is carried out in different computers operating at different hierarchical levels - typically from mainframe host computers to plant computers to the machine controller. Today the CNC systems are built around powerful 32 bit and 64 bit microprocessors. PC based systems are also becoming increasingly popular.

Manufacturing engineers also started using computers for such tasks like inventory control, demand forecasting, production planning and control etc. CNC technology was adapted in the development of co-ordinate measuring machine's (CMMs) which automated inspection. Robots were introduced to automate several tasks like machine loading, materials handling, welding, painting and assembly. All these developments led to the evolution of flexible manufacturing cells and flexible manufacturing systems in late 70's.

Evolution of Computer Aided Design (CAD), on the other hand was to cater to the geometric modeling needs of automobile and aeronautical industries. The developments in computers, design workstations, graphic cards, display devices and graphic input and output devices during the last ten years have been phenomenal. This coupled with the development of operating system with graphic user interfaces and powerful interactive (user friendly) software packages for modeling, drafting, analysis and optimization provides the necessary tools to automate the design process.

CAD in fact owes its development to the APT language project at MIT in early 50's. Several clones of APT were introduced in 80's to automatically develop NC codes from

the geometric model of the component. Now, one can model, draft, analyze, simulate, modify, optimize and create the NC code to manufacture a component and simulate the machining operation sitting at a computer workstation.

If we review the manufacturing scenario during 80's we will find that the manufacturing is characterized by a few islands of automation. In the case of design, the task is well automated. In the case of manufacture, CNC machines, DNC systems, FMC, FMS etc provide tightly controlled automation systems. Similarly computer control has been implemented in several areas like manufacturing resource planning, accounting, sales, marketing and purchase. Yet the full potential of computerization could not be obtained unless all the segments of manufacturing are integrated, permitting the transfer of data across various functional modules. This realization led to the concept of computer integrated manufacturing. Thus the implementation of CIM required the development of whole lot of computer technologies related to hardware and software.

#### 1.4 CIM HARDWARE AND CIM SOFTWARE

CIM Hardware comprises the following:

- i. Manufacturing equipment such as CNC machines or computerized work centres, robotic work cells, DNC/FMS systems, work handling and tool handling devices, storage devices, sensors, shop floor data collection devices, inspection machines etc.
- ii. Computers, controllers, CAD/CAM systems, workstations / terminals, data entry terminals, bar code readers, RFID tags, printers, plotters and other peripheral devices, modems, cables, connectors etc.,

CIM software comprises computer programmes to carry out the following functions:

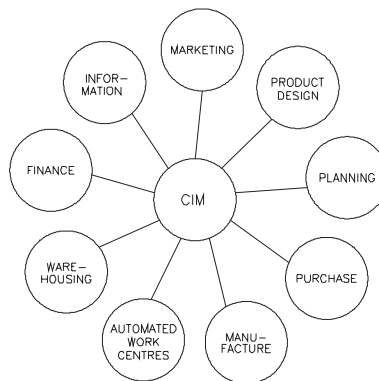
- Management Information System
- Sales
- Marketing
- Finance
- Database Management
- Modeling and Design
- Analysis
- Simulation
- Communications
- Monitoring
- Production Control
- Manufacturing Area Control
- Job Tracking

Inventory Control  
Shop Floor Data Collection  
Order Entry  
Materials Handling  
Device Drivers  
Process Planning  
Manufacturing Facilities Planning  
Work Flow Automation  
Business Process Engineering  
Network Management  
Quality Management

### 1.5 NATURE AND ROLE OF THE ELEMENTS OF CIM SYSTEM

Nine major elements of a CIM system are in Fig 1.2. They are:

Marketing  
Product Design  
Planning  
Purchase  
Manufacturing Engineering  
Factory Automation Hardware  
Warehousing  
Logistics and Supply Chain Management  
Finance  
Information Management



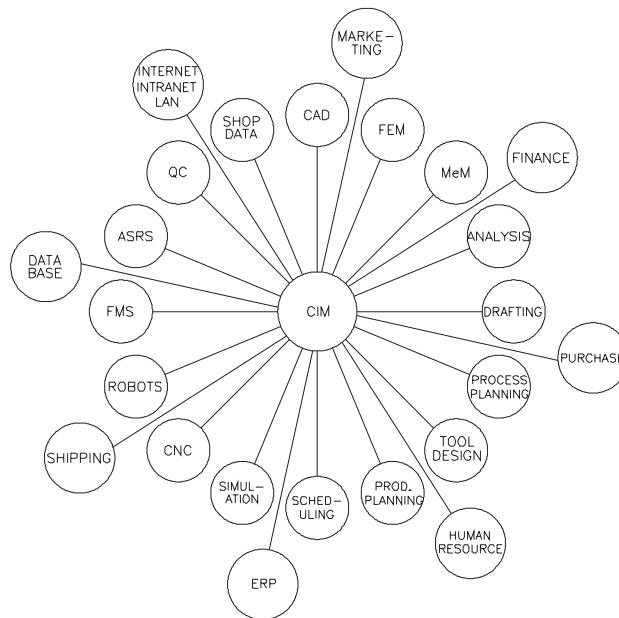
**Fig.1.2 Major Elements of a CIM System**



- i. **Marketing:** The need for a product is identified by the marketing division. The specifications of the product, the projection of manufacturing quantities and the strategy for marketing the product are also decided by the marketing department. Marketing also works out the manufacturing costs to assess the economic viability of the product.
- ii. **Product Design:** The design department of the company establishes the initial database for production of a proposed product. In a CIM system this is accomplished through activities such as geometric modeling and computer aided design while considering the product requirements and concepts generated by the creativity of the design engineer. Configuration management is an important activity in many designs. Complex designs are usually carried out by several teams working simultaneously, located often in different parts of the world. The design process is constrained by the costs that will be incurred in actual production and by the capabilities of the available production equipment and processes. The design process creates the database required to manufacture the part.
- iii. **Planning:** The planning department takes the database established by the design department and enriches it with production data and information to produce a plan for the production of the product. Planning involves several subsystems dealing with materials, facility, process, tools, manpower, capacity, scheduling, outsourcing, assembly, inspection, logistics etc. In a CIM system, this planning process should be constrained by the production costs and by the production equipment and process capability, in order to generate an optimized plan.
- iv. **Purchase:** The purchase departments is responsible for placing the purchase orders and follow up, ensure quality in the production process of the vendor, receive the items, arrange for inspection and supply the items to the stores or arrange timely delivery depending on the production schedule for eventual supply to manufacture and assembly.
- v. **Manufacturing Engineering:** Manufacturing Engineering is the activity of carrying out the production of the product, involving further enrichment of the database with performance data and information about the production equipment and processes. In CIM, this requires activities like CNC programming, simulation and computer aided scheduling of the production activity. This should include on-line dynamic scheduling and control based on the real time performance of the equipment and processes to assure continuous production activity. Often, the need to meet fluctuating market demand requires the manufacturing system flexible and agile.
- vi. **Factory Automation Hardware:** Factory automation equipment further enriches the database with equipment and process data, resident either in the operator or the equipment to carry out the production process. In CIM system this consists of computer controlled process machinery such as CNC machine tools, flexible

manufacturing systems (FMS), Computer controlled robots, material handling systems, computer controlled assembly systems, flexibly automated inspection systems and so on.

- vii. **Warehousing:** Warehousing is the function involving storage and retrieval of raw materials, components, finished goods as well as shipment of items. In today's complex outsourcing scenario and the need for just-in-time supply of components and subsystems, logistics and supply chain management assume great importance.
- viii. **Finance:** Finance deals with the resources pertaining to money. Planning of investment, working capital, and cash flow control, realization of receipts, accounting and allocation of funds are the major tasks of the finance departments.



**Fig.1.3 Various Activities in CIM**

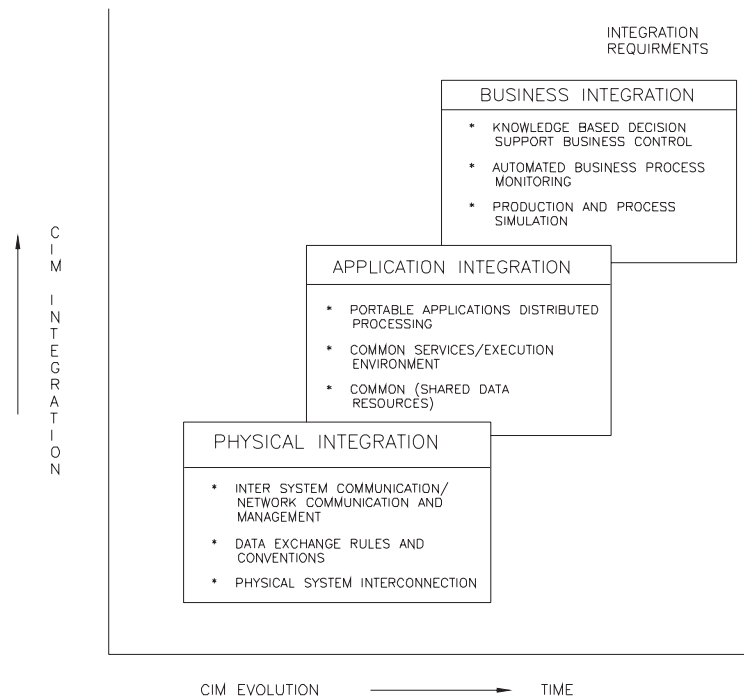
**FEM - Finite Element Modeling MeM - Mechanism Modeling ERP - Enterprise Resource Planning**

- ix. **Information Management:** Information Management is perhaps one of the crucial tasks in CIM. This involves master production scheduling, database management, communication, manufacturing systems integration and management information systems.

It can be seen from Fig 1.3 that CIM technology ties together all the manufacturing and related functions in a company. Implementation of CIM technology thus involves basically integration of all the activities of the enterprise.

## 1.6 DEVELOPMENT OF CIM

CIM is an integration process leading to the integration of the manufacturing enterprise. Fig 1.4 indicates different levels of this integration that can be seen within an industry. Dictated by the needs of the individual enterprise this process usually starts with the need to interchange information between the some of the so called *islands of automation*. Flexible manufacturing cells, automatic storage and retrieval systems, CAD/CAM based design etc. are the examples of islands of automation i.e. a sort of computer based automation achieved completely in a limited sphere of activity of an enterprise. This involves data exchange among computers, NC machines, robots, gantry systems etc. Therefore the integration process has started bottom up. The interconnection of physical systems was the first requirement to be recognized and fulfilled.



**Fig. 1.4 Levels of Integration Against Evolution of CIM**

The next level of integration, application integration in Fig 1.4 is concerned with the integration of applications, the term applications being used in the data processing sense. The applications are those which are discussed in section 1.4 under the heading CIM hardware and software. Application integration involves supply and retrieval of information, communication between application users and with the system itself. Thus the application integration level imposes constraints on the physical integration level. There has to be control of the applications themselves also.

The highest level of integration, business integration in Fig.1.4 is concerned with the management and operational processes of an enterprise. The management process provides supervisory control of the operational process which in turn co-ordinates the day-to-day execution of the activities at the application level. The business integration level therefore places constraints on the application level. This level offers considerable challenge to the integration activity.

### QUESTIONS

1. Describe the need for CIM and the issues addressed by CIM.
2. What are the different types of manufacturing? Make an assessment of the extent of computer control in specific cases of each types of manufacturing.
3. What are the various activities of a manufacturing plant which can be carried out through computer control?
4. Discuss the main elements of CIM systems.
5. Differentiate among physical integration, application integration and business integration. Give specific examples of each.

**This page  
intentionally left  
blank**

# CHAPTER

---

# PRODUCT DEVELOPMENT THROUGH CIM

# 2

*CIM helps to reduce the product development cycle time. This chapter compares sequential and concurrent approaches to product development. The importance of IT in realizing concurrency is highlighted.*

## 2.1 INTRODUCTION

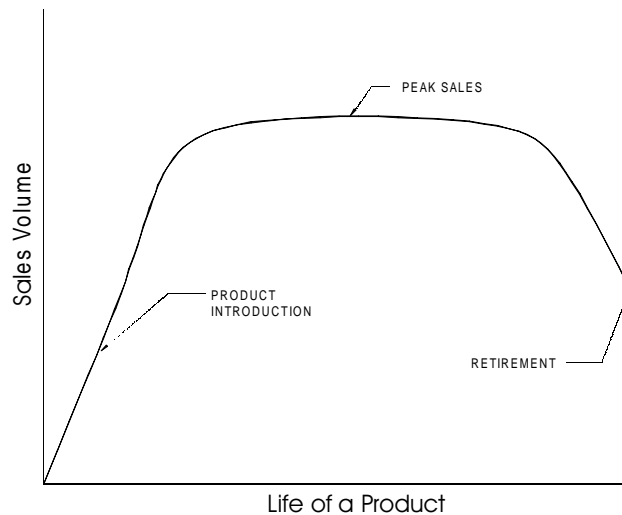
The expectations of today's customer include superior quality and performance, higher technological capabilities and on time delivery. All these are to be provided at reduced costs because of global competition faced by the manufacturing industries.

## 2.2 PRODUCT DEVELOPMENT CYCLE

Industries have to continuously upgrade their products as well as introduce new products in the market in order to retain as well as to increase their market share. The product development is the responsibility of the research and development (R&D) department of a manufacturing company. When a product is initially introduced the sales volume will be low. If the product is good and satisfies the customers, the sales will pick up. Sometimes, if there are any problems in the product the company will have to make changes or improvements in the product which is a very expensive proposition. If the defect is serious enough the company may have to recall an entire batch of products at enormous cost and loss of goodwill. The sales and service department usually takes care of attending to the customers' problems. That is why manufacturers of automobiles, entertainment electronic goods, fast moving consumer goods like washing machines and refrigerators etc have elaborate sales and service network.

The sales volume will pick up gradually and peak after some time. The product will continue to sell for some time. The sales will then start gradually declining owing to availability of better products in the market. It is time for the company to introduce a new and improved product in the market as well as to retire the old product. The companies will usually advise the customers that the old product will be further supported by the sales and service department only for a limited period of time.

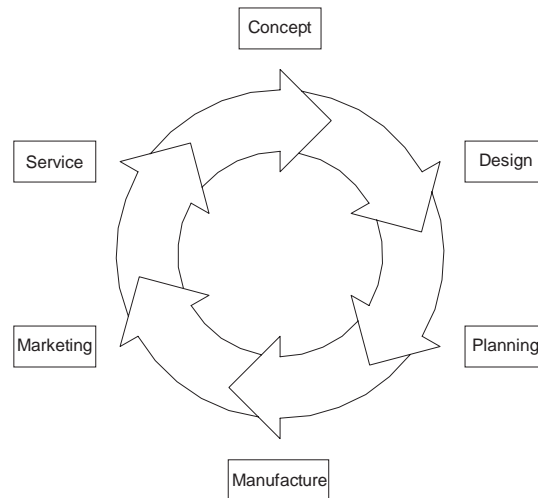
The cycle through which a product goes through from development to retirement is called the product life cycle. The variation of the sales volume during the life cycle of a product is graphically shown in Fig.2.1.



**Fig. 2.1 Variation of the Sales Volume Vs Life of a Product**

The product development cycle starts with developing the product concept, evolving the design, engineering the product, manufacturing the part, marketing and servicing. This is shown in Fig. 2.2. The idea of a product may come from a patent, suggestion of the customers, feedback of the sales and service department, market research carried out by the marketing department or from the R&D department itself. The next stage is the conceptualization of the product. The cost at which the product could be sold in the market is decided and the overall design in terms of shape, functional specifications, ergonomics, aesthetics etc are considered in detail and finalized at this stage. The work of product development is then taken to the next stage by the design department who carefully designs each assembly and each component of the assembly. Detailed design analysis and optimization is carried out at this stage. A design may have several variants. For example, a passenger car may have what is called a stripped down version with the bare minimum options and luxury versions with several add on functionalities. Between these two extreme versions, there will be a number of models or variants to meet the needs of customers with different paying capacities. In a similar way, a satellite launch vehicle may be designed for different payloads. A fighter aircraft may have different versions. A refrigerator will have to be marketed with different capacities. The design department creates these designs through a top down approach or a bottom up approach. In top down approach, the entire assembly is designed first and individual designs are done latter. In bottom up approach, the component design is done first and the product is realized by assembling the components suitably. The design also will involve preparation of detail drawings.

Engineering the product consists of process planning, tool design, facility design, capacity planning, quality assurance activities, procurement, assembly planning, etc. Marketing department will have the responsibility of carrying out appropriate product launch activities as well as planning the sales and service network, advertising and training of sales and service personnel.



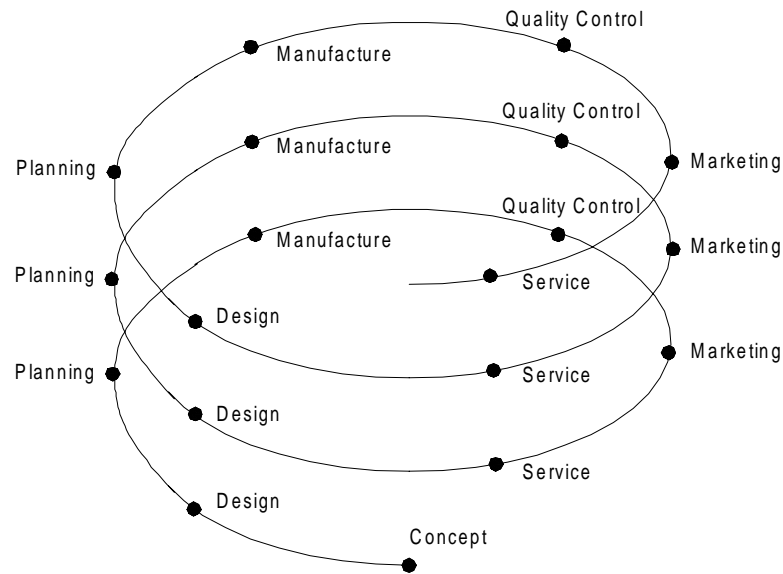
**Fig. 2.2 Product Development Cycle**

In actual practice product development activities form a spiral as shown in Fig. 2.3. The product goes through a series of continuous refinement and improvements, additions etc. A typical example is a software package improved versions of which are released as new versions at periodic intervals. The feedback from the marketing and services leads to improvements in design and/or evolution of new designs. As an example, the reader is advised to make a study of the evolution of the various models of aircraft or passenger cars over the last five decades.

This is how most of the present products have been evolved over the period. One can evidently realize it by comparing a 1928 model T Ford car with the current jelly bean shaped cars. However, the design evolution however does not stop at any stage and is a continuous process.

Similarly one can observe the vast improvements that have taken place in the design of entertainment electronic goods, computers, aircrafts and even domestic appliances like refrigerators. Often an altogether new concept may make a design obsolete. Songs were recorded at different times on discs, tapes, cassettes and CD-ROMS. Correspondingly, the design of the music player has also undergone radical changes from the old gramophone record player to the present MP3 player. It is interesting to note the rate of obsolescence of technology in music players.



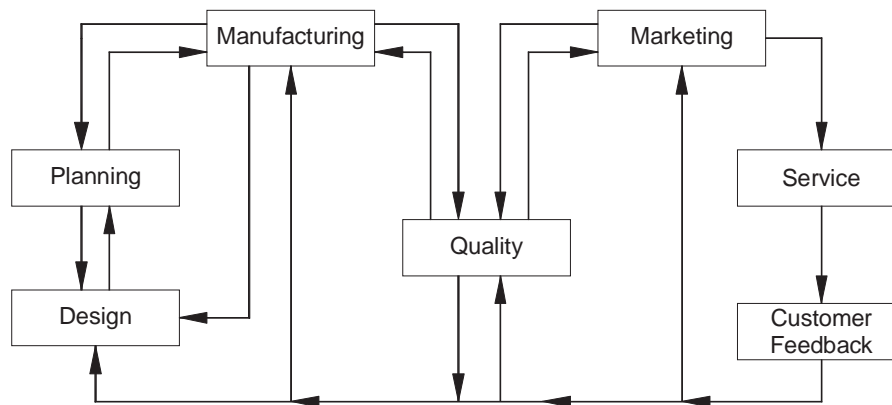


**Fig. 2.3 Product Development Spiral**

### 2.3 SEQUENTIAL ENGINEERING

The traditional product development process at the prototype development stage is sequential. It includes product design, development of manufacturing process and supporting quality and testing activities, all carried out one after another. This situation assumes that there is no interaction among the major departments involved in product manufacturing during the initial development process. Often the need for engineering changes is discovered during planning or manufacturing or assembly. Design department in a typical sequential product development process finalizes the design without consulting the manufacturing, quality or purchase departments. Planning might feel it necessary to request design changes based on a number of reasons like the procurement or facility limitations. Changes in design may be called for when the manufacturing department is unable to meet design specifications or there are problems in assembly. These changes are however to be incorporated in design. The design documents are therefore sent back to the design department for incorporating the changes. The design/redesign path is shown in Fig. 2.4. The design documents are passed on back and forth to incorporate design changes as illustrated. This will lead to inevitable conflicts, each department sticking to their own decisions and may often require intervention of senior management to resolve conflicts or differences in opinion. Design changes will involve both material and time wastages. In such a situation, time taken to product development is usually more than what is anticipated and correspondingly the response to the market requirements will be slow compared to a competing company which can create an error free design at the first instance. In an age of reduced product life cycles as we witness

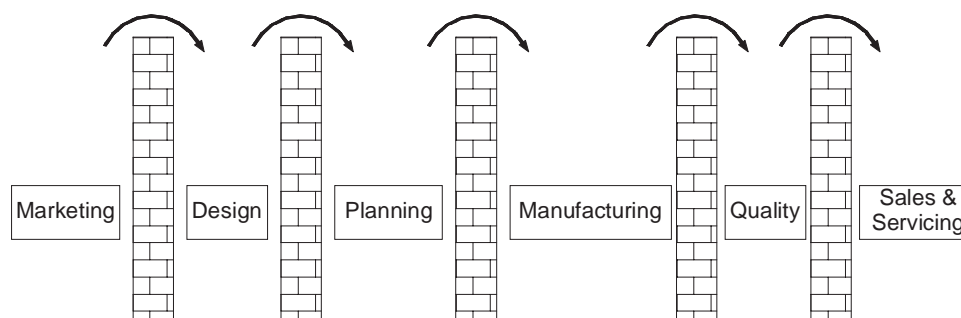
today the time delay between market demand and introduction of product in the market has to be as short as possible. Sequential product development process, therefore, may not suit the present global scenario.



**Fig. 2.4 Design and Redesign Path**

Even after the prototype development stage is over, the need for design change may arise during service. Such changes are usually few in number, but are very costly.

Thus in the traditional manufacturing, the design documents move sequentially through the various departments of the organization. The R & D group completes the design task and passes the data to planning, which in turn passes the information to manufacturing and so on. If any downstream department wants to introduce any change, the process has to backtrack and this often involves additional expenditure as well as inevitable delay in realizing the product.



**Fig. 2.5 Across the Wall Approach in Sequential Engineering**

Sequential Engineering is often called “across the wall” method. Figure 2.5 illustrates the insulated way each department may function in sequential approach. Each segment of the product development team (Design, Planning, Manufacturing etc.) completes its

task in isolation and passes over the documents to the next segment. There is no interaction among the groups before the design is finalized. If a serious mistake in the product is detected during testing, the revision process has to start from design, resulting in materials wastage and loss of time. In the context of extensive outsourcing, there is also need for intensive consultation between vendors and manufacturers.

## 2.4 CONCURRENT ENGINEERING

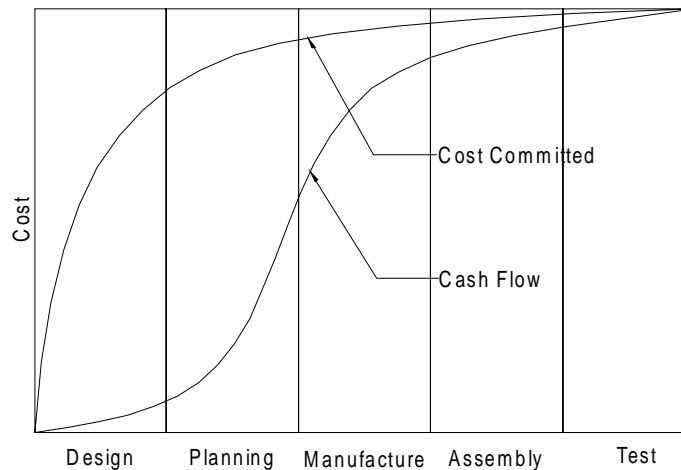
Concurrent engineering or Simultaneous Engineering is a methodology of restructuring the product development activity in a manufacturing organization using a cross functional team approach and is a technique adopted to improve the efficiency of product design and reduce the product development cycle time. This is also sometimes referred to as Parallel Engineering. Concurrent Engineering brings together a wide spectrum of people from several functional areas in the design and manufacture of a product. Representatives from R & D, engineering, manufacturing, materials management, quality assurance, marketing etc. develop the product as a team. Everyone interacts with each other from the start, and they perform their tasks in parallel. The team reviews the design from the point of view of marketing, process, tool design and procurement, operation, facility and capacity planning, design for manufacturability, assembly, testing and maintenance, standardization, procurement of components and sub-assemblies, quality assurance etc as the design is evolved. Even the vendor development department is associated with the prototype development. Any possible bottleneck in the development process is thoroughly studied and rectified. All the departments get a chance to review the design and identify delays and difficulties. The departments can start their own processes simultaneously. For example, the tool design, procurement of material and machinery and recruitment and training of manpower which contributes to considerable delay can be taken up simultaneously as the design development is in progress. Issues are debated thoroughly and conflicts are resolved amicably.

Concurrent Engineering (CE) gives marketing and other groups the opportunity to review the design during the modeling, prototyping and soft tooling phases of development. CAD systems especially 3D modelers can play an important role in early product development phases. In fact, they can become the core of the CE. They offer a visual check when design changes cost the least.

Intensive teamwork between product development, production planning and manufacturing is essential for satisfactory implementation of concurrent engineering. The teamwork also brings additional advantages ; the co-operation between various specialists and systematic application of special methods such as QFD (Quality Function Deployment), DFMA (Design for Manufacture and Assembly) and FMEA (Failure Mode and Effect Analysis) ensures quick optimization of design and early detection of possible faults in product and production planning. This additionally leads to reduction in lead time which reduces cost of production and guarantees better quality.

## 2.5 COMPARISON OF CONCURRENT ENGINEERING AND SEQUENTIAL ENGINEERING

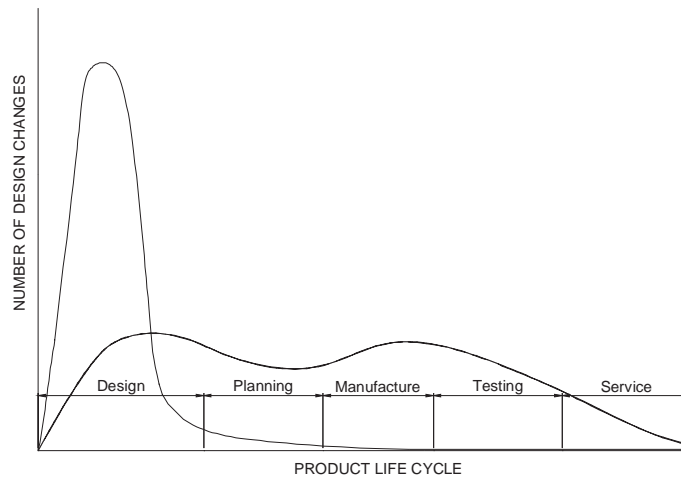
A comparison of concurrent and sequential engineering based on cost is attempted in this section. The distribution of the product development cost during the product development cycle is shown in Fig. 2.6. This figure shows that though only about 15% of the budget is spent at the time of design completion, whereas the remaining 85% is already committed. The decisions taken during the design stage have an important bearing on the cost of the development of the product. Therefore the development cost and product cost can be reduced by proper and careful design. CE facilitates this. The significantly large number of nonconformities detected in the later stages of product development cycle in sequential engineering results in large time and cost overrun.



**Fig. 2.6 Distribution of Product Development Cost**

### 2.5.1 REDUCTION IN THE NUMBER OF DESIGN CHANGES

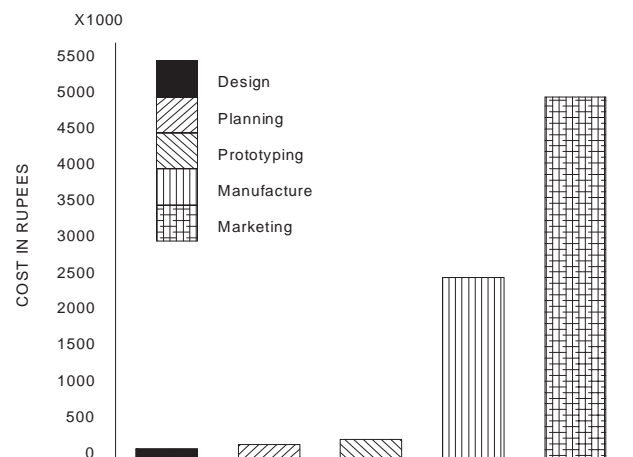
The advantage of concurrent engineering over the traditional sequential (SE) and concurrent engineering (CE) is that a large number of design changes are identified and implemented at the beginning or in the early phase of product development cycle. In the case of CE this number goes on decreasing for the remaining period, whereas many changes are now and then incorporated at every stage of development in the case of traditional sequential approach. This is due to the fact that most of the design changes needed are detected early in design. The reduction in design change requests with CE is substantially less at the later stages of the product development process. Compared to this, defects are detected often during the sequential engineering process. This is shown graphically in Fig. 2.7.



**Fig. 2.7 Distribution of Design Changes Across the Life Cycle of a Product**

### 2.5.2 COST OF CHANGES IN DESIGN

The cost of introducing a design change in a product progressively increases as the development proceeds through design and manufacturing. This can be elaborated with a simple example. If a change in the conceptual 3D CAD model costs Rs.50,000. The same change during the planning stage would cost Rs.1,50,000. By the time the product moves to prototyping and testing, the change may cost Rs.2,50,000. The cost goes up to Rs.25,00,000 if the product is in the manufacturing stage and Rs.50,00,000 or more after the company releases the product to sales and marketing. Figure 2.8 illustrates this. While these numbers differ greatly from company to company and from product to product, they give a feel of the importance of feedback early in the design cycle.



**Fig. 2.8 Cost of Design Change**

### 2.5.3 HOLISTIC APPROACH TO PRODUCT DEVELOPMENT

Concurrent engineering approach introduces a new philosophy in product development. No longer is product development considered the exclusive activity of the design department. Participation of planning, manufacturing, quality, service, vendor development and marketing personnel in the development process enables the cross functional team to view the development as a total responsibility and this results in better communication among the various departments.

### 2.5.4 ROBUST PRODUCTS

Concurrent approach to product design results in products with fewer errors and therefore avoids the loss of goodwill of the customers due to poorly engineered products. The entire product development team looks at each and every aspect of products – cost, specifications, aesthetics, ergonomics, performance and maintainability. The resulting product will naturally satisfy the customer.

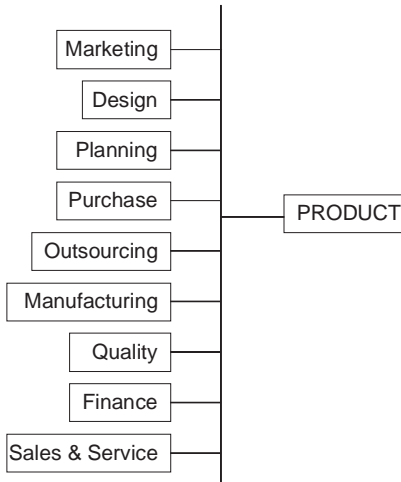
### 2.5.5 REDUCTION IN LEAD TIME FOR PRODUCT DEVELOPMENT

Time compression in product development is an important issue today. Concurrent engineering reduces the product development time significantly as the preparatory work in all downstream functions can take place concurrently with design. Elimination of the errors in design appreciably reduces the possibility of time overrun, enabling the development schedule to be maintained.

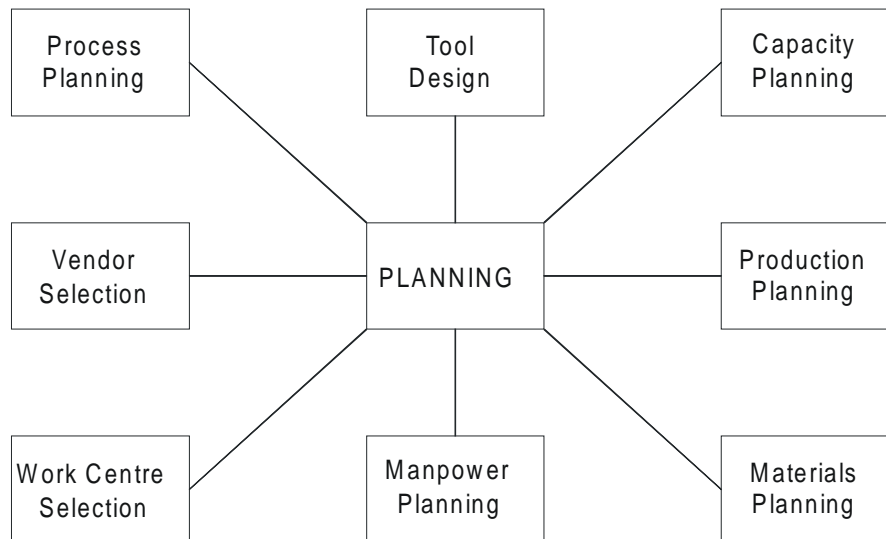
## 2.6 IMPLEMENTATION OF CONCURRENT ENGINEERING

The cycle of engineering design and manufacturing planning involves interrelated activities in different engineering disciplines simultaneously, than sequentially as shown in Fig. 2.9 (A). In addition, the activities necessary to complete a particular task within a specific engineering discipline have to emerge wherever possible from their sequential flow into a concurrent workflow with a high degree of parallelism as illustrated in Fig. 2.9 (B). Concurrency implies that members of the multidisciplinary project team work in parallel. This also means that there is no strict demarcation of jobs among various departments. The multi-disciplinary approach has the advantage of several inputs which can be focused effectively early in the design process. Presently engineering departments are practicing this approach but still with a high degree of manual involvement and redundancy. Planning scenarios experience a similar approach. One of the most critical links in the entire product life cycle, i.e. the close interaction between design and manufacturing has been made possible in concurrent engineering. Thus the product development process has been freed from the large number of constraints arising from the limitations of the sequential engineering. This has changed the way manufacturers bring the products to market. For example, many manufacturers no longer view product development as a relay race in which marketing passes the baton to R &D, which in turn passes it to manufacturing. Representatives drawn from marketing, planning, design,

purchase, vendors, manufacturing, quality control and other department participate in product development right from the beginning. Concurrent engineering is thus a cross-functional approach to product design. Total quality management which is being practiced by many companies is closely related to concurrent engineering.



**Fig. 2.9 (a) Concurrent Engineering**



**Fig. 2.9 (B) Concurrent Workflow Within An Activity**

## 2.7 CONCURRENT ENGINEERING AND INFORMATION TECHNOLOGY

The challenge to engineering information systems today is to have the ability to handle very large amount of data and information which the engineering organizations have to cope with. Design changes, status reviews, releases and their effects on cost, delivery and quality have to be managed. It has to be made sure that the workplace of each engineer, planner and manager is not overloaded so as to make the work ineffective.

Concurrent or simultaneous engineering is an orthogonal concept that defines how concurrent and simultaneous work flows are organized and the information flow, storage, retrieval and decision making can be supported and controlled. In particular the principles and methods of concurrent or simultaneous engineering integrate these activities through the information technology (IT). Hence IT is the backbone of this approach. Software tools are available today to perform all the manufacturing related activities. These tools today permit almost seamless transfer of data from one application to another. The possibilities of extensive reuse of data are another welcome feature. Naturally IT assures productivity increase and shorter overall cycle times with improved quality.

The product design is currently carried out using a wide range of related and reasonably well integrated design support tools. A number of tools exist in the market which addresses the specific requirements of certain design activities. The manufacturing engineers have a wide choice today to manage product development through product life cycle management (PLM) software. However, there exists no coherent view yet as to how the design activity should be structured to provide rapid throughput of satisfactorily validated designs. The approach therefore will be to identify the necessary tools required for the design of products and include all of them in some kind of integrated platform. Concurrent engineering together with CIM aims to achieve this objective. Thus concurrent engineering helps to create an environment in which teams of product engineers can develop products from initial concept to prototype and to final product with the integration of manufacturing engineering and design of production facilities.

The pressure to be the first in the market with a new product requires the design to be right from the beginning. Therefore in every phase of the product development, from concept to final design, sufficient information has to be provided to the product development team based on which the members of the team take the right decisions with respect to production, production planning and product support. Special attention has to be given to the adoption of new production technologies and to take make or buy decisions including the early integration of the suppliers into the development process.

As a result of these requirements, information systems have to be developed which integrate the different engineering disciplines and their support tools, promoting and pushing a conversion of the currently practiced sequential work flow into a more concurrent work flow with a higher degree of parallelism to shorten the product development lead-time.



Presently, IT vendors offer a variety of tools for implementing some form of concurrent engineering. The tools can be broken into the following main technological groups:

- Knowledge based engineering, production tools and communication tools
- Relational database management systems for data management
- Work flow automation and product life cycle management (PLM) systems
- Decision support systems
- Enterprise resource planning systems

Table 2.1 shows a breakdown of the available technology in the market for implementation of Concurrent Engineering.

**TABLE 2.1 Software Technologies Available for Concurrent Engineering**

<i>Design</i>	<i>Planning/Manufacture</i>	<i>Visualization/Simulation</i>
Solid modeling	Process planning	Factory Simulation
Surface modeling	ERP	Simulation software for-
Assembly modeling	Generative machining	• Welding
	Shop floor data collection	• Casting
Sheet metal design	Human machine interface	• Forming
Drafting	Job tracking	• Forging
Tolerance analysis	Work in process inventory	• Plastic injection molding-
Mechanism design	tracking	• Robot operation
Finite Element analysis	PDM, VPDM and PLMSoftware for-	• Machining etc.
Harness design	• EDM	• Rapid Prototyping
Mold design	• Wire EDM	
Mold flow analysis	• Press brake	
Dynamic analysis	• Grinding	
Thermal analysis	• Turret Punch Press	
Composites design		
Piping design		
Optimization		
Tool design		
Standard part libraries		

Through concurrent engineering, every aspect of the future product will be considered at the same time. The individual departments representing different activities like design, process planning, production planning, subcontracting, purchase, manufacture, assembly and quality assurance can make important contribution to product definition and preferably these have to be incorporated in the design and in the early phases of life-cycle. Thus,

information that comes up usually during later phases such as assembly constraints or product costs can be taken into account during the design stage itself. So the number of constraints which have to be considered in early phases increases and most of the product and process behavior can be simulated and optimized using concurrent engineering tools.

## 2.8 SOFT AND HARD PROTOTYPING

CAD systems with solid modeling capabilities can be useful when implementing CE. A solid model of a part, or an assembly of solid parts, provides a more complete product definition.

Boeing Commercial Airplane Group uses the CATIA solid modeling product developed by Dassault Systems of France. Boeing's goal is to store every airplane part in solid format. The solid models let Boeing spot interference problems before expensive mock-ups are built. The savings are significant. In India, too, this approach is followed for aircraft development. One of the biggest paybacks Boeing is experiencing is the visualization benefits of solid modeling. It gives their engineers a realistic view of the part. They can print color images of the parts and share them with other groups inside and outside the organization. Since Boeing subcontractors build about half of the parts that go into their planes, the company sends bidding subcontractors solid models of parts along with specifications of the part. This reduces the percentage the subcontractors normally add to cover the cost of ambiguities in a design, saving Boeing millions of dollars. Rapid prototyping (RP) takes the concept a step further. If you have access to RP, you can show the part itself to people inside and outside the organization. This not only gives them an instant view of the part and therefore there will not be any ambiguity in interpreting the features of the component. Quotations from subcontractors are then likely to be more accurate.

It is not always necessary to have a costly solid modeling package to practice concurrent engineering. Even a modeling package like AutoCAD can play a more strategic role in an organization - a role for more important than isolated functions like drafting.

## 2.9 CHARACTERISTICS OF CONCURRENT ENGINEERING

In concurrent engineering functional divisions like design, manufacturing and quality are integrated in a compatible environment. The integration comes in the form of instant delivery of information about business processes across the enterprise. Cross functional units co-operate concurrently rather than sequentially. The real-time sharing of information enables teams to make design modifications early in a product development cycle, thus reducing unwanted rework and engineering changes that increase cost of operations, reduce product quality and delay the time-to-market.

The concurrent engineering approach can be characterized by the following factors:

- Integration of product and process development and logistics support
- Closer attention to the needs of customers

- Adoption of new technologies
- Continuous review of design and development process
- Rapid and automated information exchange
- Cross functional teams
- Rapid prototyping

## 2.10 KEY FACTORS INFLUENCING THE SUCCESS OF CE

Introduction of the concurrent engineering approach requires consideration of several important factors. Starting CE with top management is not always ideal because many unilateral initiatives from the top are likely to fail. Directives, training programs, reorganizations and pep talks, have been ineffective given the magnitude of change needed to implement CE.

CE can succeed if it comes from bottom up in the organization. If those at the bottom share the concerns and agree that a problem exists, they are more likely to work together to solve it. In addition several problems are to be considered before introducing CE.

Despite the challenges a manufacturing company may meet, CE will result in considerable reduction in product development time. It should be realized that it may take some time to make the members of the team to work together.

There are several examples of successful implementation of CE. Hewlett Packard is one such example. Its joint venture in Japan, Yokogawa Hewlett-Packard, reported amazing improvements after implementing CE. Over a five year period, R & D's cycle time decreased by 35%, manufacturing costs declined 42%, inventory dropped 64% and field failure rates fell by 60%. Meanwhile its market share tripled and profits doubled.

## 2.11 EXAMPLE OF CONCURRENT ENGINEERING

The story of the development of Neon Car in USA is a typical example of success of concurrent engineering. The planning of the car started in August 1990. For each major item product teams were made. Supporting teams were organized for such activities like dimension control, materials etc. The composition of a typical team included representatives from engineering, stamping, manufacturing processes, assembly, design, purchase, finance, product planning, materials handling and vendor development. Even suppliers were part of the product development team. Each team took approximately one year to complete a task. Subsequently process teams were organized to manufacture the product. Four months before the launch the process teams were converted into launch teams to successfully introduce the product in the market.

Another example for successful implementation of concurrent engineering is the development of Scooty moped and other products by TVS Motors Ltd. in India. Before taking up the design cross functional teams were formed to design and engineer the product.

This reduced not only the product development time but also helped the manufacturer to introduce the quality product in the market.

## 2.12 TECHNIQUES TO IMPROVE MANUFACTURABILITY AND REDUCE LEAD TIME

The lead time for product development is the period of time between the go ahead signal to develop the product is given to the time when the product is ready to be released in the market. Previous sections dealt with the various stages through which the development cycle has to go through. This product development lead time varies from product to product. Increase in global competition has compelled the manufacturers to progressively reduce the product development time. A set of tools have been developed to examine the design from different points of view like convenience in manufacture, assessment of risks in design, assembly, testing, servicing etc. These tools are generally labeled as “design for X”, where X stands for cost, manufacture, assembly, testing, servicing etc. During as well as at the end of the process of design it is now customary to examine the designs based on certain specific considerations. They are listed below:

1. Is the design of parts such that they can be easily manufactured or fabricated? This is referred to as design for manufacturing.
2. Is the product design such that the product can be assembled fast, easily and economically? Does the part design lend itself for automation of assembly?
3. Is the product design is such that the product can be tested easily? Many of the IC and microchip designs should facilitate easy testing.
4. Is the product design such that the product can be easily serviced? One of the plus points of a good design is its easy serviceability regardless whether it is a computer or a washing machine.
5. Is the design carried out such that the cost is globally competitive? Today cost of the product is a very important consideration. Most of the designs start from a targeted selling price and the corresponding production cost.

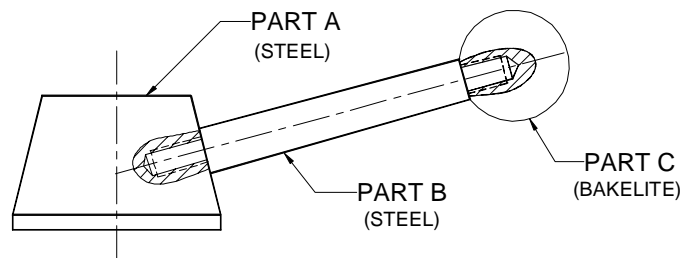
Five important considerations are mentioned above – manufacture, assembly, testing, service and cost. These can be a few other considerations too depending upon the product.

### 2.12.1 CURRENT APPROACH TO “DESIGN FOR X”

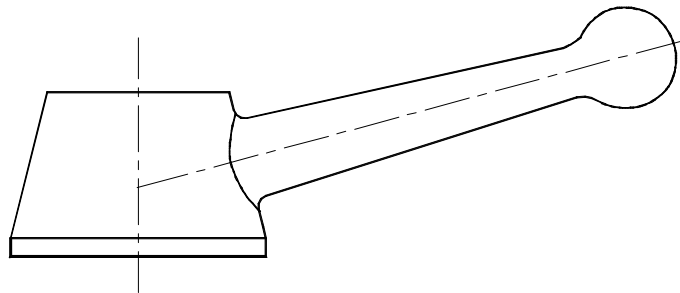
There are some common guidelines which can be followed to satisfy the above five considerations. They are discussed below:

- i. **Design with less number of parts and subassemblies:** Cost and time to market can be considerably reduced if the number of parts is reduced. Figure 2.10 shows a clamping lever assembly which can be cited and example of reduction in the number of parts. The clamp assembly has 3 parts (two steel and 1 plastic), each requiring several machining operations. Finally two parts are to be chrome plated. This assembly can be replaced by a simple die cast part shown in Fig. 2.11 or a plastic

clamp, thereby reducing the design and manufacturing cost. The alternative parts are available off the shelf. The new design is superior from the point of view of manufacturability. It is also cheaper and aesthetically superior. This trend is particularly seen in aircraft and automotive industry. Increased use of sophisticated CNC machines like 5 axis machines and multitasking machines enables us to integrate several parts into a single monolithic part. This approach not only drastically reduces set up times but also improves the accuracy and makes available a part for assembly much earlier. A typical example where cost, quality and performance could be improved through integration in ICs and VLSI chips. The concept of a system on a chip further reduced cost and improved reliability.



**Fig. 2.10 Design of a Clamping Lever**



**Fig. 2.11 Improved Design of Clamping Lever**

Introduction of high power series motors in spindle drives of CNC machines eliminated the need for a gear box, thereby not only improving performance but also reducing cost. The integral rotor spindles used in high speed CNC machines further reduced the number of kinematic elements in main drive. The use of linear motors in reciprocating drives eliminated not only ball screws and nuts but also paved way for increasing linear traverse speeds.

Another example of improvement of design is shown in Fig. 2.12. Fig. 2.12 (A) shows the assembly which require the use of a screw driver. The number of parts required in 3. The assembly required aligning the screw and a screwdriver. The manufacture can be simplified using a rivet, thereby eliminating the threading operation (B). Making the rivet integral with one part reduces the total number of parts to two (C). The design can be further improved using a snap fit approach (D). An alternative design can be joining the two parts by a spot weld which may be cheaper than all the previous designs.

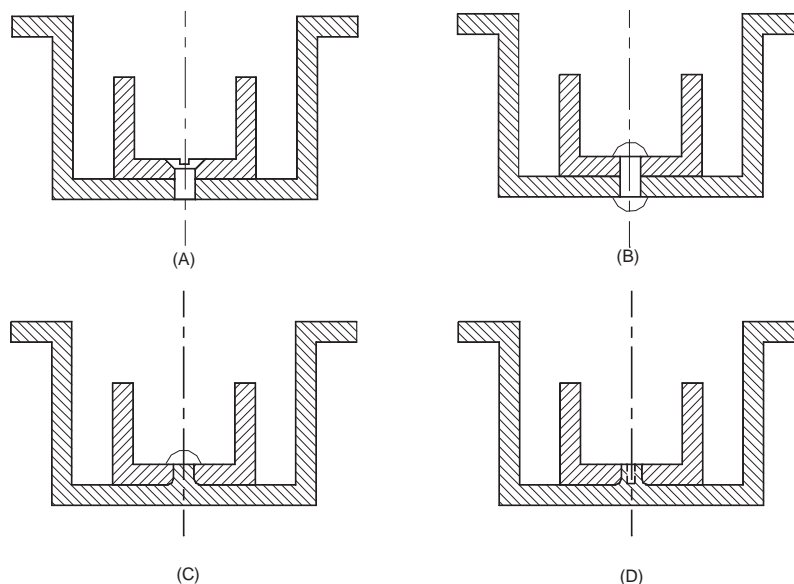
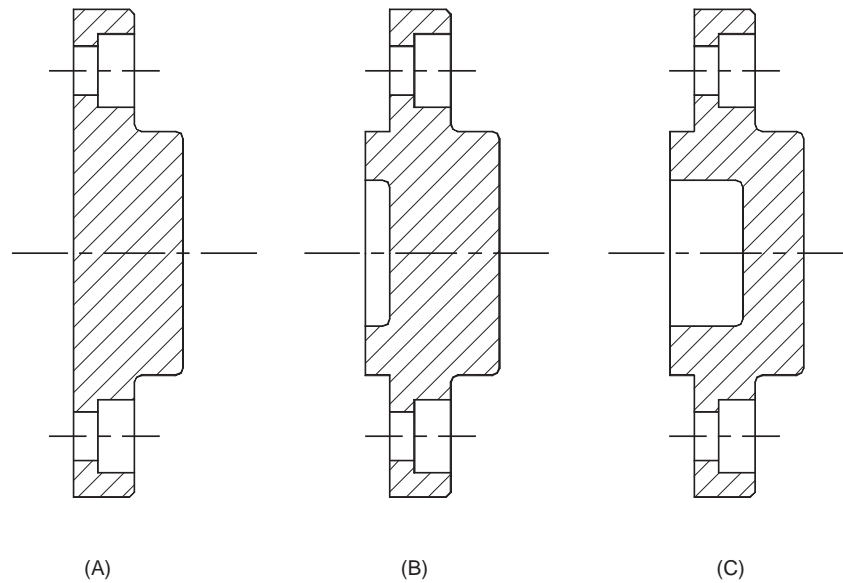


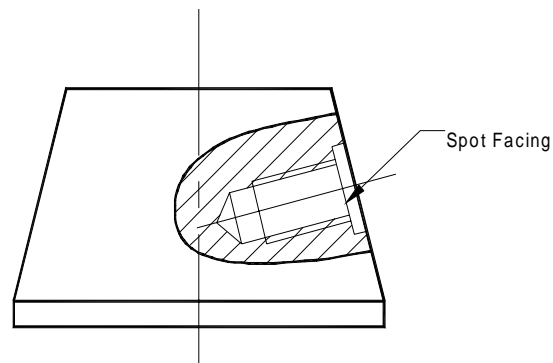
Fig. 2.12 Improvements in Design

- ii. **A product may be made in many variations to meet specific customer needs or end use:** It is advisable to keep as many parts as standard to minimize product variations. Automotive manufacturers adopt this approach very effectively. They create many designs from the same platform and components often by adding options only. This keeps the cost of the product variations to a minimum.
- iii. **Fastener is a critical factor which makes easy assembly:** A sound principle that could be followed is that minimum variety and number only should be used. If there are socket head cap screws used, then use only one type so that a single Allen key is necessary. This will reduce the assembly time by eliminating the need to change Allen keys and eliminate the need to keep inventory of a variety of screws while assembling as well as the need to supply many tools for servicing. If possible, fastener could be altogether eliminated. Adhesive bonding and snap fit are examples. Both lend themselves to easy automation. The reader could realize the advantages of a snap fit assembly if a cell phone is examined.



**Fig. 2.13 Design for Ease of Manufacture**

- iv. **Ease of fabrication and is very critical:** Take the case of an end cover shown in Fig. 2.13. The provision of a locating spigot will make the assembly easy. (Fig. 1.13 (B)) Making the thickness of the casting of the cover uniform [Note the change in the thickness of the end cover from Fig. 2.13(B) to Fig. 2.13 (C)] makes casting defect free. Provision of a chamfer at the mouth of the tapped hole facilitates easy entry and alignment of screw while fastening. Chamfers in the bore and at the end of the socket make assembly easier. A few examples of how careful detailed design will improve assembly are discussed here.
- v. **Designing for easy manufacture:** Designers have to think about easiness in manufacture. Take for example part A in Fig. 2.10 which is shown separately in Fig. 2.14. There is an angular core hole to be drilled to make the tapped hole. Since the drilling is to be done on a conical face, the drill is likely to wander. Creating a flat surface by spot facing prior to drilling makes the drilling process easy.
- vi. **Specify proper tolerances:** Designers often have a tendency to play safe. This results in specifying tighter tolerances. For example, a simple drilled hole through which a bolt has to pass through need not have a 7<sup>th</sup> grade tolerance. A 10<sup>th</sup> or 12<sup>th</sup> grade or general tolerance will do for this purpose. Care must be taken when specifying surface finish for such a hole. N8 finish will be adequate here which requires only a drilling operation. If N7 is indicated, the process engineer will be required to introduce a reaming operation, which is not needed here. Not only such designs increase time and cost but also will result in increase in the inventory of tools.



**Fig. 2.14 Example for Improved Design for Manufacture**

Specifying tolerances should take into consideration the process capability of the machines. Mismatch of tolerance specified on the component and the machine's process capability will result in avoidable rejections.

Rework is another offshoot of specifying tighter or incompatible tolerances. Rework will result in delay in assembly and has to be avoided as much as possible.

Even though the designer may specify a bilateral tolerance, the manufacturing engineer has to understand the end use. For example, if a part length is specified as  $100^{+/-0.1}$ , it may be advisable to keep the dimension close to 99.9 in the case of an aircraft structural part. This will result in reduction in over all weight. If the tolerances are maintained on all components near the higher limit, there will be considerable increase in weight affecting the payload capacity.

- vii. **Standardization is another important issue:** Standardization not only reduces design effort but also cost. Let us take the example of modular fixtures. Before the advent of modular fixtures aircraft industry had to make several thousand new fixtures for each aircraft project. Once the model is scrapped, most of the fixtures also may be scrapped. Further, it is necessary to have a large storage area and an efficient system to retrieve the fixtures. With modular fixturing, the need to maintain such large inventory is eliminated. Once the use is over, the fixture can be dismantled and the fixture components can be used for another fixture. The design is also easy as all the suppliers of modular fixtures supply also a matching CAD library. Thus both the design and tool realization time are substantially reduced with modular fixtures.

Standardization will make maintenance and replacement of parts easy. The design lead time will also be reduced.

- viii. **Minimize setups:** Increase in the number of set ups has the risk of stack up of tolerances apart from delay and cost increase. 5 axis machines, multitasking machines, machines capable of 5 side machining, etc. reduce the number of setups. Reduction in the number of setups reduces handling as well as the number of fixtures required.



- ix. **Avoid frequent design changes:** Design changes are often unavoidable. However, frequent design changes will create confusion and attendant wastage. It is recommended that design changes are to be taken up at specified time intervals. A typical example is software. This policy is good for engineering goods too.

## 2.13 IMPROVING THE DESIGN

Continuous improvement is what every manufacturer is required to practice. Whenever a new product is to be introduced it has to be done after careful analysis of the design. There are several techniques available for carrying out this. Some are listed below:

- i. Value stream mapping.
- ii. Failure mode and effect analysis.

### 2.13.1 VALUE STREAM MAPPING (VSM)

Toyota production system is a well known approach for efficient and responsive production system. The lean manufacturing technique which is now being followed widely is an integral part of Toyota Production System. This was pioneered by Taichi Ohno and sensei Shigeo Shingo. Value stream mapping (VSM) is a visualization tool in the Toyota Production System. Value stream is essentially a communication tool but can also be used as strategic planning tool as well as change management tool.

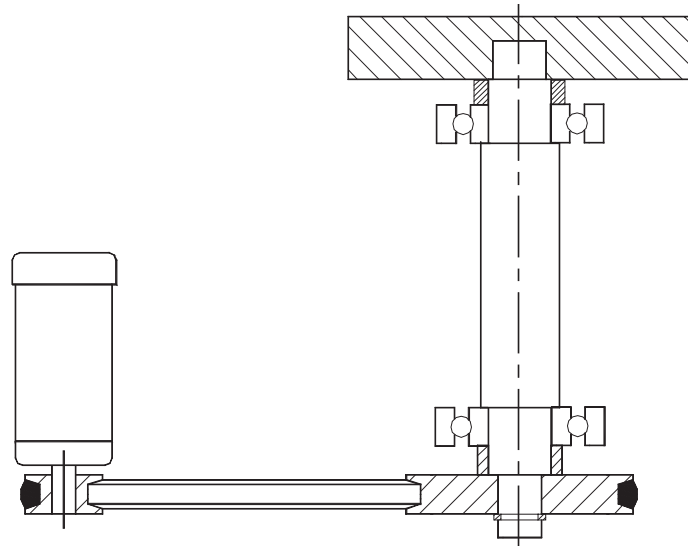
Waste is an activity that does not add value to the final product. In a poorly designed manufacturing process, there may be several waste elements. VSM is used to recognize these elements, identify their causes, and decrease waste in a manufacturing process.

The value stream mapping technique visually maps the flow of materials and information from the arrival of raw materials and sub assemblies to the shipping of the finished product. Mapping out the various activities with corresponding operating and idle times (cycle times), work in process inventory (WIP), movement of materials from one work centre to the next and the flow of information helps to correctly visualize the present state of affairs in a given process. This will give the necessary directions as to how the waste could be eliminated to gain competitive advantage. It is thus a systematic attack on waste. The common wastes are overproduction, waiting, transport, inappropriate processing, excess stock, unnecessary motion and rejects. The value stream mapping tools are process activity mapping, supply chain response matrix, production variety funnel, quality filter mapping, demand amplification mapping, decision point analysis and physical structure mapping.

### 2.13.2 FAILURE MODE AND EFFECT ANALYSIS (FMEA)

Failure mode and effect analysis gives a design team with an organized approach to evaluate the causes and effects of various modes of failure of a product. The objective of this exercise is to improve the quality of the product by anticipating failures and redesigning the part to eliminate such failures.

For example, let us consider the design of a lapping table shown in Fig. 2.15. The kinematic elements in the design include motor, belt, shaft, pulleys, bearings etc. First step in FMEA is to list all possible modes of failure. Each of the elements may fail in many different ways. For example, in the case of the shaft, the failure may occur due to fatigue, shear, bending stress, von Mises stress, etc. Similarly each one of the other elements may fail due to many reasons. All these failures are ranked according to their effect on the system. Failures that may result in total failure of the systems are ranked high and those who do not directly affect the function are ranked low, Design improvements are then incorporated to reduce the chances of failure. Often this exercise may lead to considerable improvements in the robustness, reduction in cost, improvements in serviceability and simplification of design. A detailed functional analysis as to what the product should deliver may lead to considerable modifications and even may bring out redundancy of parts in some cases.



**Fig. 2.15 Kinematic Chain of a Lapping Machine**

### 2.13.3 FAILURE MODES, EFFECTS AND CRITICALITY ANALYSIS

Various industries have their own failure modes and effects analysis standards some of which are mentioned below:

<b>Manufacturer</b>	<b>Standard</b>
Aerospace and Defense Products	MIL-STD-1629A SAE ARP 5580
Automotive suppliers	SAE 1739 AIAG FMEA
General	IEC 60812 BS 5760

Automotive manufacturers like Daimler Chrysler, FORD and General Motors use their own FMEA methodologies. There are other standards like RAC FMD – 97 and HAZOP (Hazards and Operability) data. FMD-97 data specifies component failure modes and the percentages of time that these modes are responsible for failures HAZOP software can be used for identifying potential hazards and operability problems caused by deviations from the design intent both the new and existing processes.

## 2.14 TAGUCHI METHOD FOR ROBUST DESIGN

This method is eminently suitable for improving the quality of products and processes making them more robust. The performance of a product or process may be influenced by several parameters. Let us take the simple example of optimizing the life of a simple helical reduction gear box. There are several parameters influencing the performance of a gear:

- i. Number of teeth
- ii. Face width ratio
- iii. Addendum modification
- iv. Surface hardness

It may be desirable that certain parameters like centre distance, reduction ratio, material etc. have to be kept constant. A study can be conducted to evaluate these parameters at two or three levels. A suitable combination of these parameters can be selected using standard orthogonal arrays like L8 or L9. This will minimize the number of experiments to be performed. Using analysis of variance or signal to noise ratio it is possible to determine the most important parameter and the values of the parameters.

The process of optimizing the processes is similar. An example is taken from the direct metal laser sintering process. The process variables are laser power, layer thickness, sintering speed, hatch interval, pre-contouring, post-contouring, hatch type size of metal powder etc. Laser power, layer thickness and powder size may be constant for a given machine. The parameters that can be varied in the study are then sintering, pre-contouring, post-contouring, hatch interval and hatch type. What is of interest is the combination of process parameters that leads to best strength, highest accuracy and best surface finish. Trials can be conducted using a standard experimental pattern suggested by Taguchi. The study can lead to better understanding of the process and the interdependence of parameters and often can yield valuable information to improve the process further.

## 2.15 VALUE ENGINEERING

Value Engineering is another useful tool to improve the products and processes. The term value is defined as the ratio of function or performance to cost. The purpose of value engineering is to maximize the value of the product by improving its functional capability. This is achieved by reducing the cost of each function without sacrificing the function at all.

The value of the product can be classified into two:

- i. The ability of the product to satisfy the needs of the user.
- ii. Esteem value which is a measure of the desirability of the product.

The most important component of value engineering is defining its function. Each component of the product and the product itself is given a functional statement and that function is assigned a numerical value. Cost of that function is determined on the basis of manufacturing costs and other components of the costs. This is perhaps the most difficult part of value engineering.

## 2.16 PRODUCT LIFE CYCLE MANAGEMENT

Manufacturing, very often has been based on the concept of make to stock. This will however continue in the case of many products like machine tools, electronic entertainment products etc. However, the preferences of customers are now being given more importance. Many manufacturers follow the concepts of assembled to order or engineered to order. In the former, the manufacturer assembles a product to the specific requirements of the customer. For example, assume that a customer orders a car with windscreen wipers which can sense the rain and automatically start or stop wipers. This requirement is passed on to the assembly line of the car to assemble a car conforming to the customer's requirements. In such cases, the manufacturer offers a basket of options and assembles a product to meet the specifications of the buyer. In the case of engineered to order products, right from design, the product is engineered to meet the specifications of the customer. Whatever be the case, a manufacturer has to consider the following issues:

- (i) **Cost efficiency:** Ability to manufacture a product at a predefined cost that it could be profitably sold.
- (ii) **Product quality:** Maintain a quality level comparable, if not better than competitor's products and continuously improve the quality.
- (iii) **Design for manufacture and assembly:** Design the product in such a way that the product can be manufactured, and assembled with ease.
- (iv) **Time to market:** Agility to sense the market requirements and bring a new product into the market ahead of the competitors. This means that manufacturers must be able to get it right first time every time. There is very little scope for costly iterations.
- (v) **Serviceability:** Engineer a product in such a manner that in case there is a malfunctioning, it can be easily attended to. It must also be possible to refurbish if necessary after the lapse of a few years, recycle part of the product and retune the product at an appropriate stage when it is technologically obsolete.

The concept of making all parts or subassemblies of a product under one roof is giving way to massive outsourcing. The design and manufacturing activity is thus carried out not in one location but in many locations distributed all around the world. The

manufacturing value chain is more complex and in order to efficiently manufacture a product today depends much on a suite of software called product life cycle management (PLM). This software views the entire life cycle of a product as a process that can be managed, measured, monitored and modified to achieve continuous improvement.

PLM is a bundle of technologies that tie together all product related data. Basically all engineering activities related to manufacture are role based. For example, designers would like to use CAD models for early analysis, simulation and optimization. A process planning engineer would like to access the features of the geometry of the part. A manufacturing engineer will be interested to study the easy access of the tool to machined surfaces in order to minimize the number of setups and reduce the throughput time. A marketing engineer has no use for the above information. He may be interested only in the shape description through a VRML file. Thus each of the manufacturing roles is interested in only a part of the product database and the best technologies available to process the database to carry out his assigned task. More and more manufacturers today outsource a part or their full requirements. Many outsourced components go into designs when manufactured should reach the market with minimum or no flaws.

Another critical requirement is in managing design changes. These are inevitable today, as all products should respond to market changes. Such product changes should be reflected in all the drawings and bill of materials concerned so that the design changes can be seamlessly incorporated. The scope of the PLM software is such that manufacturers acquire the capability to collaborate internally (within the organization) and externally (outsourcing partners or vendors) collaborate on product development, manufacture, market and service till the retirement of the product, consistently maintaining the highest possible efficiency throughout the value chain. A significant advantage of PLM packages is that they are Internet based and therefore it can enable the manufacturers to change their business models. The importance of logistics and supply chain management in today's global manufacturing scenario needs no emphasis. Equally important are enterprise resource planning, (ERP) and customer relationship management (CRM). Interoperability is the order of the day. PLM does provide this functionality.

PLM permits the product data to be visualized in several forms:

- 3D CAD Models
- Bill of Materials
- Schematic Diagrams
- Schedules
- Forecasts.

### **2.16.1 PLM SOFTWARES**

There are a number of vendors of PLM software today.

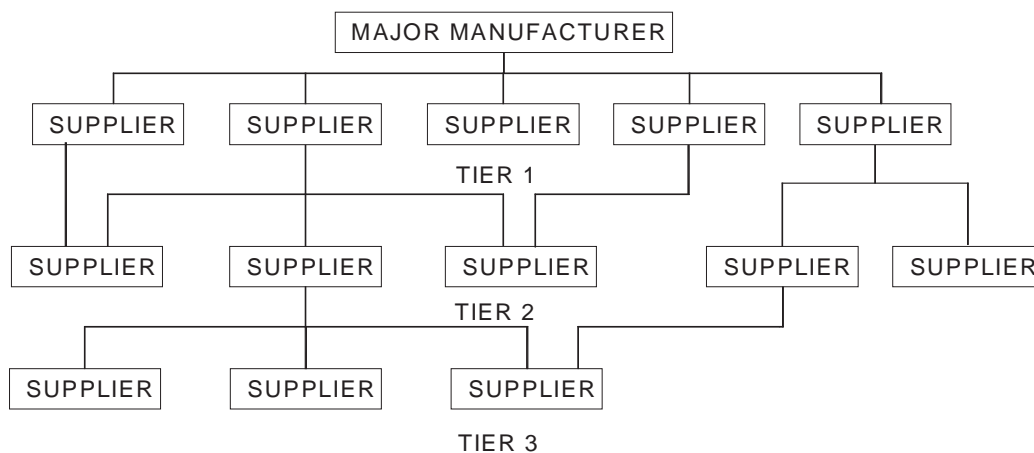
- (i) PTC
- (ii) SDRC/EDS

- (iii) Matrix One
- (iv) SmarTeam
- (v) Agile Software
- (vi) Co-Create
- (vii) Frame Work Technologies
- (viii) IBM/Dassault systems
- (ix) Alventive
- (x) Centric software
- (xi) BOM COM
- (xii) Baan
- (xiii) SAP
- (xiv) People Soft/JD Edwards/Oracle

Hardware manufacturers like HP/Compaq, IBM, Fujitsu, Siemens and SUN also realized the importance of PLM and developed their PLM softwares. PLM represent the move away from the paper based product development and manufacture. In the present globalized manufacturing scenario, there is need for streamlining the entire product life cycle management internally as well as externally. It is the key to competitiveness in manufacturing and can be equally applicable to small, medium and large companies.

### 2.16.2 OUTSOURCING CHAIN

Outsourcing today is considered very critical to keep the costs down. Manufacturers outsource from tier 1 suppliers who in turn outsource from tier 2 suppliers and so on. Figure 2.16 shows the outsourcing chain. Outsourcing chain is thus today can be quite complex spanning even continents. PLM software solutions enable manufacturers manage their outsourcing efficiently.



**Fig. 2.16 Outsourcing Chain**

### 2.16.3 PLM AND CONCURRENT ENGINEERING

PLM helps the product developers to try many solutions within the same development time window through efficient collaboration and communication among various partners involved in development. PLM enables all stakeholders to provide their inputs early in the development cycle so that the high costs associated with design changes introduced later in the development cycle can be eliminated. This will also reduce the time overrun significantly as the errors that cripple production and delivery processes are avoided. PLM extends the power of collaboration to other outside entities like business partners, distributors, customers, analysts etc. Since product information is available early in the development cycle, numerous product readiness activities like creation of product literature, and other product promotion efforts and training could be taken up concurrently, within the limited time to market window.

### 2.16.4 OTHER ADVANTAGES OF PLM

Apart from evolving new business models, PLM has enabled manufacturers to reduce the time to market new products, design products which could perform better and thereby facilitate product innovation improve manufacturability and quality, reduce costs through reduction of wastage and make collaborative design and manufacture seamless and efficient within and outside the organization. Customer satisfaction is ensured by capturing the product related expectations and preferences of the targeted customers and align the design to satisfy these requirements. This also helps to deliver product enhancements that stretch the product life cycle.

### 2.16.5 COMPONENTS OF PLM SOFTWARE

A PLM software suite many consists of a number of modules. These are discussed below:

- (i) **Engineering design:** Multiple CAD/CAE/CAM softwares are used by designers to create designs. These are used for product design which includes creation of designs, release of designs, design management, engineering process management, digital validation, change management and design collaboration in multi-sites. Design analysis also incorporate creation of virtual prototypes which can be used to check interference as well as clearances, ergonomic and aesthetic studies, convenience for assembly and disassembly and fit and function studies. PLM software converts native CAD files into a suitable neutral format so that extended product teams can study components and assemblies.
- (ii) **Knowledge management and process automation:** PLM allows the user to capture, integrate, secure and control all product, process manufacturing and service knowledge in a single repository. Design capture, documentation, vaulting, versioning control, product structure and configuration management, etc. facilitate effective knowledge management. Visualization and collaboration capabilities enable team members to view the digital mock up or exchange

product representations. Other facilities provided by PLM packages are process management, change management, parts classification, release management, and version management.

- (iii) **Product visualization:** Aesthetics and ergonomics play vital roles in the market acceptability of a product. Sales and marketing organizations, suppliers, customers etc. are part of the extended life cycle family and they have an important role in configuring the product at the conceptual design stage. Visualization also includes 2D/3D markup, dynamic cross sectioning and measurements capabilities. It must be possible to assemble an advanced digital mockup to carry out various analyses on the whole product.
- (iv) **Real time collaboration:** Secure, adaptive and user friendly real time collaborative environment is required to facilitate rapid sourcing, carry out concept studies, program reviews, design reviews, and for incorporating engineering changes.
- (v) **Managing life cycle projects:** Creating, maintaining and monitoring project schedules that reflect tasks, dependencies, milestones and start to finish dates are very important to carry out a successful project. Project tracking and reporting capabilities are useful for executives to create updates. Emails and POP up notifications, event based notices etc. enable the executives to take care of trouble spots. This will also help to make reviews and cost control effective.
- (vi) **Assessing and capturing customer requirements:** Understanding target markets and the needs of the customers are key elements in the success of a product.
- (vii) **Supply chain management:** Sourcing is an important activity and efficient management of sourcing plays an important role in productivity, cost control and shortening time to market. Efficient and cost effective sourcing is very essential to retain the competitive edge in the global market. PLM software integrates the procurement related processes with the rest of engineering and product development activities. PLM software enables the suppliers to appreciate their role in the product development cycle. The suppliers can thus fully understand the manufacturer's requirements, supply chain needs and product definitions. The product development team can assess through the various functionalities of this module each prospective supplier in terms of design content, cost efficiency and product quality as well as supplier's capabilities.
- (viii) **Manufacturing:** In addition to the physical factory PLM helps to build a company a digital factory and creates the data to feed all the downstream manufacturing execution system using the data from the product definition process. The manufacturing module performs the following functions:
  - Part manufacturing planning
  - Assembly process planning
  - Factory layout and analysis
  - Robot programming and simulation
  - Worker safety and ergonomic studies
  - Computer aided manufacturing



- (ix) **Servicing capability:** The processes associated with maintaining, repairing and overhauling machinery and equipment are digitally enabled by this module. Service manuals, repair and overhaul procedure, bill of materials, change histories, compliance and regulatory standards, equipment availability, time to repair and optimization of the cost of servicing are some of the components of this module.

## QUESTIONS

1. Discuss the stages in the product life cycle and the importance of each stage.
2. List and describe various activities involved in product development.
3. Study an industrial product and discuss how the product is evolved and perfected continuously.
4. What are the drawbacks of sequential engineering in handling design change requests?
5. Discuss the significance of concurrent engineering approach in limiting design changes.
6. How does IT facilitate concurrent engineering?
7. Discuss how CIM can act as an enabling technology for concurrent engineering.
8. How will concurrent engineering will help to reduce product development time?
9. Discuss important guidelines to examine the manufacturability of a design.
10. What is meant by robust design?
11. What are the techniques commonly used to improve a design?
12. Describe how the Taguchi technique can be used to evolve a robust design.
13. What is meant by value stream mapping? How is it useful in product development?
14. Discuss the application of Failure Mode and Effect Analysis to improve a design.
15. What is PLM?
16. What are the core issues addressed by PLM?
17. How does PLM help in outsourcing?
18. What are the components of PLM software?

# PRINCIPLES OF COMPUTER GRAPHICS

*The display of the drawing or the geometric model of the component in CAD uses the technology of computer graphics. The techniques of raster technology, scan conversion, clipping, removal of hidden lines and hidden surfaces, color, shading and texture, necessary to understand the complex process of computer graphics are briefly dealt in this chapter.*

## 3.1 INTRODUCTION

Traditionally drawings are prepared on plane drawing sheets. This has several limitations. The sketches have to be made only in two dimensions. Though the depth can be represented by pictorial projections like isometric and perspective projections, the projections have to be necessarily reduced to two dimensions.

Use of computer graphics has opened up tremendous possibilities for the designer. Some of them are listed below:

- The object is represented by its geometric model in three dimensions (X, Y and Z).
- The mathematical representation reduces creation of views like orthographic, isometric, axonometric or perspective projections into simple viewing transformations.
- Though the size of the screen is limited, there is no need to scale the drawings.
- Drawings can be made very accurate.
- The geometric models can be represented in color and can be viewed from any angle.
- Sections can be automatically created.
- The associativity ensures that any change made in one of the related views will automatically reflect in other views.
- Revision and revision control are easy.
- Drawings (geometric models) can be modified easily.
- More important than all, drawings can be reused conveniently.
- Storage and retrieval of drawings are easy.

Modern computer graphics displays are simple in construction. They consist of basically three components.

- i. Monitor
- ii. Digital Memory or Frame Buffer
- iii. Display Controller

Most of the computer graphics displays use raster CRT which is a matrix of discrete cells each of which can be made bright. A graphic entity like line or circle is represented as a series of "points or dots" on the screen. Therefore, it is called as a point plotting device.

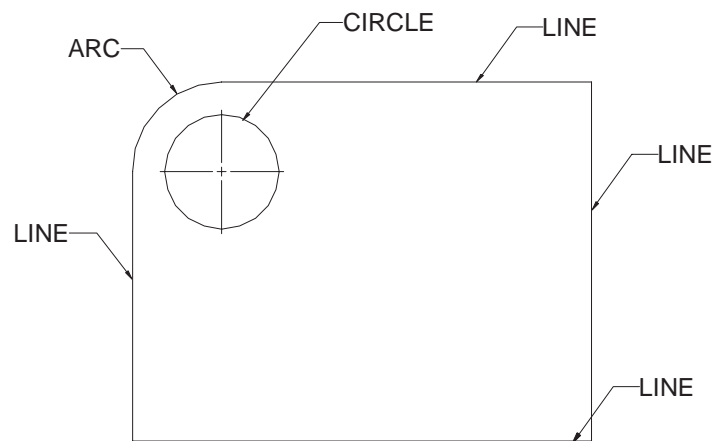
The video display screen is divided into very small rectangular elements called a picture element or pixel. This happens to be the smallest addressable screen element. Graphic images are formed by setting suitable intensity and color to the pixels which compose the image. Depending upon the resolution screens may have varying number of pixels. For example, an SVGA monitor with a resolution of 1024 x 768 will have 1024 pixels in every row (X - direction) and 768 pixels in every column (Y-direction). Monitors of larger size will have resolution of 1024 x 1024 or more. A raster scan system displays the image on a CRT in a certain fixed sequence.

The refresh rate is the number of complete images or frames scanned per second. In the case of interlaced refresh cycle odd numbered raster lines are refreshed during 1/60th of a second. Even numbered raster lines are refreshed during the next 1/60th of a second. In non-interlaced displays, all lines are refreshed in 1/60th of a second. The quality of non-interlaced display is hence, superior. These systems, however, require expensive frame buffer memory and display controller.

## 3.2 GRAPHIC PRIMITIVES

A drawing is created by an assembly of points, lines, arcs, circles. For example, drawing shown in Fig 3.1 consists of several entities. In computer graphics also drawings are created in a similar manner. Each of these is called an entity. The drawing entities that a user may find in a typical CAD package include :

- point
- line
- construction line, multi-line, polyline
- circle
- spline
- arc
- ellipse
- polygon
- rectangle



**Fig. 3.1 A Simple Drawing**

The fundamental principles of generation of some of these entities are discussed below :

### 3.3 POINT PLOTTING

The frame buffer display is an example of a point plotting device. The smallest unit accepted by such displays is a single pixel. To construct a useful picture on a point plotting device, a picture must be built out of several hundreds of pixels.

### 3.4 DRAWING OF LINES

Straight line segments are used a great deal in computer generated pictures. The following criteria have been stipulated for line drawing displays :

- i. Lines should appear straight
- ii. Lines should terminate accurately
- iii. Lines should have constant density
- iv. Line density should be independent of length and angle
- v. Line should be drawn rapidly

The process of turning on the pixels for a line segment is called vector generation. If the end points of the line segment are known, there are several schemes for selecting the pixels between the end pixels. One method of generating a line segment is a symmetrical digital differential analyzer (DDA).

#### 3.4.1 DDA ALGORITHM

The digital differential analyzer generates lines from their differential equations. The DDA works on the principle that X and Y are simultaneously incremented by small steps proportional to the first derivatives of X and Y. In the case of a straight line the first derivatives are constant and are proportional to DX and DY, where D is a small quantity.

In the real world of limited precision displays, addressable pixels only must be generated. This can be done by rounding to the next integer after each incremental step. After rounding, a pixel is displayed at the resultant X and Y locations. An alternative to rounding is the use of arithmetic overflow. X and Y are kept in registers that have integer and fractional parts. The incrementing values which are less than unity are repeatedly added to the fractional part and whenever the result overflows the corresponding integer part is incremented. The integer parts of X and Y are used to plot the line. This would normally have the effect of truncating. The DDA is therefore initialized by adding 0.5 in each of the fractional parts to achieve true rounding.

The symmetrical DDA generates reasonably accurate lines since a displayed pixel is never away from a true line by half the pixel unit. A Pascal procedure for a simple DDA is given below :

```

Procedure DDA (X1, Y1, X2, Y2 : integer) ;
    length : var ;
    i : integer;
    X, Y, X-incr, Y-incr : real ;

begin
    length := abs (X2- X1) ;
    if abs (Y2-Y1) < length then length:= abs (Y2-Y1);
    X - incr := (X2 - X1) /length ;
    Y - incr := (Y2 - Y1) /length ;
    X := X1 + 0.5 ; Y = Y1 + 0.5 ;
    for i := 1 to length do
begin
    plot (trunc (X) ; trunc(Y) ;
X := X + X - incr ;
    Y := Y + Y - incr ;
    end;
end.

```

### 3.4.2 EXAMPLE

To draw a straight line from connecting two points (2, 7) and (15, 10)

$$X1 = 2, X2 = 15 \text{ abs}(X2 - X1) = 13$$

$$Y1 = 7, Y2 = 10 \text{ abs}(Y2 - Y1) = 3$$

Length = 13

$$X \text{ incr} = \frac{X_2 - X_1}{\text{Length}} = \frac{13}{13} = 1$$

$$Y \text{ incr} = \frac{Y_2 - Y_1}{\text{Length}} = \frac{3}{13} = 0.23$$

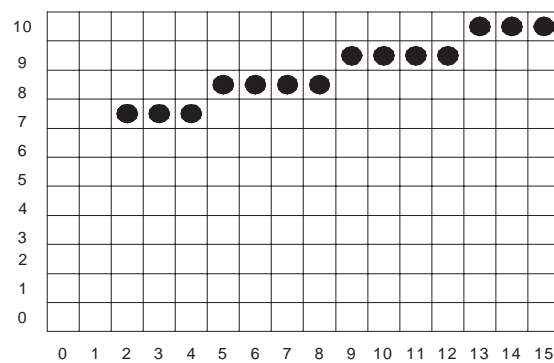
Initial values of X and Y are

$$X = 2.5 \quad Y = 7.5$$

The X and Y are tabulated in Table 3.1 and Fig. 3.2 shows a plot of the line.

**Table 3.1 Pixel Values**

X	Y	<i>trunc</i> (X)	<i>trunc</i> (Y)
2.5	7.50	2	7
3.5	7.73	3	7
4.5	7.96	4	7
5.5	8.19	5	8
6.5	8.42	6	8
7.5	8.65	7	8
8.5	8.88	8	8
9.5	9.11	9	9
10.5	9.34	10	9
11.5	9.57	11	9
12.5	9.80	12	9
13.5	10.23	13	10
14.5	10.46	14	10
15.5	10.69	15	10



**Fig. 3.2 Plotting a Line**

It can be noted that lines drawn on a raster display may have a jagged or staircase appearance unless the lines are vertical or horizontal. This is because the points that are plotted must be pixel grid points and many of these may not lie on the actual line.

### 3.4.3 DRAWING OF CIRCLES

Circle is another important entity like line. Several circle drawing algorithms have been described in literature. A simple procedure for drawing a circle is described in this section.

This procedure calculates points on the circle centred about the origin and then adds co-ordinates of the centre (X,Y) to the X and Y values respectively.

```

program mcircle;
var xc, yc, radius : integer;
($I GRAPH.P)
Procedure dcircle
    (xc, yc,
    radius: integer) ;
var
    dtheta,
    cdtheta, sdtheta,
    x, y,
    xtemp: real ;
    z: integer ;
begin
    dtheta := 1/radius ;
    cdtheta:= cos(dtheta) ;
    sdtheta:= sin(dtheta) ;
    x:= radius;
    y:= 0;
    for z: 0 to 45 do
        begin
            plot (round (xc + x), round (yc + y), 1);
            plot (round (xc - x), round (yc + y), 1);
            plot (round (xc + x), round (yc - y), 1);
            plot (round (xc - x), round (yc - y), 1);
            plot (round (xc + y), round (yc + x), 1);
            plot (round (xc - y), round (yc + x), 1);
            plot (round (xc + y), round (yc - x), 1);
            plot (round (xc - y), round (yc - x), 1);
        end
    xtemp:= x ;

```

```

        x := (x* cdtheta - y*sdtheta) ;
        y := (y*cdtheta + x*sdtheta) ;
            end ;

    end ;

begin
    writln(enter xc,yc,radius);
    readln(xc);
    readln(yc);
    readln(radius);
        clrscr;
    graphcolormode;
    palette(3);
    dcircle(xc,yc,radius)
end of a circle.

```

### 3.5 BRESENHAM'S CIRCLE ALGORITHM

Bresenham's algorithm enables the selection of optimum raster locations to represent a straight line. In this algorithm either pixels along X or Y directions are incremented by one unit depending upon the slope of the line. The increment in the other direction is determined by examining the error or distance between actual line location and the nearest grid locations.

The principle of Bresenham's algorithm can be explained with the aid of Fig 3.3 a. If the slope of the line (in the first octant) is more than  $1/2$ , the pixel point in the Y direction is shifted by one. Thus lines L1 and L2 passes through pixel (0,0). For line L2 slope is greater than  $1/2$ ; hence the pixel point is (1,1) whereas for L1 the slope is less than  $1/2$  and hence (1,0) is the pixel point.

Bresenham's algorithm selects optimum raster locations with minimum computation. To accomplish this, the algorithm always increments by one unit in either X or Y depending upon the slope of the line. The increment in the other variable either zero or one is determined by examining the distance (error) between the actual line location and the nearest grid location. Only the sign of this error needs be examined.

Consider the line of slope  $m = 0.4$  and passing through (0,0) in Fig 3.3 (a). The error term  $e$  is initialized to  $-1/2$ . The next raster point can be determined by adding the slope ( $m$ ) to the error term.

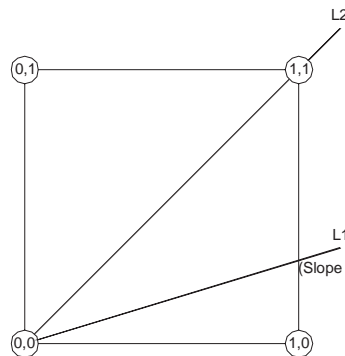
$$\begin{aligned} \text{i.e.} \quad e &= e + m \\ e &= -0.5 + 0.4 = -0.1 \end{aligned}$$



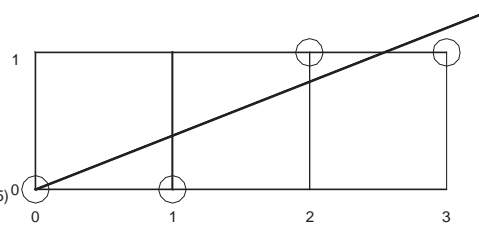
Since  $e$  is negative, the line will pass below the middle of the pixel. Hence the pixel is at the same horizontal level i.e.,  $(0,1)$ . For the next location  $X$  is incremented to 2. Error  $e = -0.1 + 0.4 = 0.3$ . Since  $e$  is positive the line passes above the middle of the raster line. Hence the location of pixel is  $(2,1)$ . Before examining the next pixel location the error term has to be re-initialized as its value is positive. Re-initialization is done by subtracting one from the current  $e$  value. Hence  $e = 0.3 - 1 = -0.7$ . Adding the slope  $0.4$  we get  $e = -0.3$ . Table 3.2 shows the computed values and the location of pixels. A plot of the pixel location is shown in Fig. 3.3 (b).

**Table 3.2 Calculation of Pixel Position**

$X$	$Error$	$Y$	$Remarks$
0	-0.5	0	initial pixel
1	$-0.5 + 0.4 = -0.1$	0	
2	$-0.1 + 0.4 = 0.3$	1	
	$0.3 - 1 = -0.7$		
3	$-0.7 + 0.4 = -0.3$	1	
4	$-0.3 + 0.4 = 0.1$	2	
	$0.1 - 1 = -0.9$		reinitialize the error by subtracting one
	$-0.9 + 0.4 = -0.5$	2	
5	$-0.5 + 0.4 = -0.1$	2	
6			



**Fig. 3.3 (a) Location of Pixels Using Bresenham Algorithm**



**Fig. 3.3 (b) Pixels for Line of Slope,  $m = 0.4$**

The speed of the Bresenham's algorithm can be increased by using integer arithmetic and eliminating division to determine slope.

The pseudo code and a C-program for implementing Bresenham's algorithm are given below:

#### **Pseudo code for Bresenham's line-drawing algorithm**

Given a line from  $x_1, y_1$  to  $x_2, y_2$  ...

$dx$  is the difference between the  $x$  components of end points

$dy$  is the difference between the  $y$  components of end points

```

ix is the absolute value of dx
iy is the absolute value of dy
inc is the larger of dx, dy
plotx is x1
ploty is y1 (the beginning of line)
x starts at 0
y starts at 0
plot a pixel at plotx, ploty
    increment x using ix
    increment y using iy
    plot is false
    if x is greater than inc
        plot is true
        decrement x using inc
        increment plotx if dx is positive
        decrement plotx if dx is negative
    if y is greater than inc
        plot is true
        decrement y using inc
        increment ploty if dy is positive
        decrement ploty if dy is negative
    if plot is true, plot a pixel at plotx, ploty
    increment i.

```

### Program in Turbo-C to draw a line

```

#include <stdio. h>
#include <graphics. h>
#include <stdlib. h>
void draw line (int x1, int y1, int x2, int y2),
void main (void)
{
    draw line (100, 100, 50, 50) ;
}
void draw line (int x1, int y1, int x2 m int y2)
{
    int dx, dy, inc, ix, iy, x, y, plot, plotx, ploty, i ;

```

```
int gd, gm ;
gd = DETECT ;
initgraph (&gd, &gm, " ");
dx = x1 - x2 ;
dy = y1 - y2 ;
ix = abs (dx) ;
iy = abs (dy) ;
inc = max (ix, iy) ;
x = y = 0 ;
plot x = x1 ;
plot y = y1 ;
for (i = 0 ; i < inc ; i ++ )
{
    x + = ix ;
    y + iy ;
    plot = 0
    if (x > inc)
    {
        plot = 1 ;
        x - = inc ;
        if (dx < 0)
            plot x - = 1 ;
    }
    else
        plotx + = 1 ;
}
if (y > inc)
{
    plot = 1 ;
    y - = inc ;
    if (dy)
        ploty - = 1 ;
    else
        ploty + = 1 ;
}

if (plot)
```

```

        putpixel (plotx, ploty, 1)
    else
    }
    getch ( ) ;
    closegraph ( ) ;

```

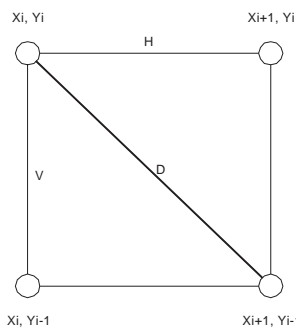
### 3.5.1 BRESENHAM'S CIRCLE ALGORITHM

An efficient algorithm for generating a circle has been developed by J. Bresenham. Values of a circle centred at the origin are computed in the sector  $X = 0$  to  $X = R / 2$  where  $R$  is the radius of the circle. The symmetry of the circle is used to obtain the pixels corresponding to other sectors.

Bresenham's circle algorithm can be explained as follows:

Consider an origin-centred circle. The algorithm begins at  $X = 0$  and  $Y = R$ . In the first quadrant of the circle,  $Y$  is a monotonically decreasing function of  $X$ . Referring to Fig. 3.4,  $(X_i, Y_i)$  is a point on the circle. For clockwise generation of the circle there are only three possible selections of the next pixel, which represents the circle. These positions are also shown in Fig. 3.4. The algorithm is designed to choose the pixel which minimizes the square of the distance between one of these pixels and the true circle, i.e., the minimum of

$$\begin{aligned}
 H &= [ (X_i + 1)^2 + (Y_i)^2 - R^2 ] \\
 V &= [ (X_i)^2 + (Y_i - 1)^2 - R^2 ] \\
 D &= [ (X_i + 1)^2 + (Y_i - 1)^2 - R^2 ]
 \end{aligned}$$



**Fig. 3.4 First Quadrant Pixel Position**

A flow chart to obtain the pixel values for representing a circle is given in Fig. 3.5. It is sufficient to obtain the pixel values for  $1/8$ th of a circle, the remaining obtained by symmetry.

A program which implements Bresenham's algorithm follows.

```

include <stdio.h>
include <graphics.h>

```

```
Void draw circle (int xc, int yc, int y) ;
Void symmetry (int x, int y, int xc, int yc) ;
double ratio ;
Void main (void)
{
    draw circle (300, 150, 50) ;
}
int d, x ;
int gd, gm ;
    gd = DETECT ;
    initgraph (&gd, &gm, " ") ;
    d = 3 - 2 * y ;
    ratio = 1.5
    x = 0 ;
    while (x < y)
    {
        symmetry (x, y, xc, yc) ;
        if (d < 0)
            d + = 4 * x + 6 ;
        else
        {
            d + = 4 * (X - Y) + 10 ;
            y - :
        }
        x++ ;
        if (x == y)
            symmetry (x, y, xc, yc) ;
    }
    getch ( ) ;
    closegraph ( ) ;
}
void symmetry (int x, int y, int xc, int yc)
{
    int x start, x end, x out ;

    int y start, y end, y out ;
    x start = x * ratio
    x end = (x + 1) * ratio ;
    y start = y * ratio ;
```

```

y end = (y + 1) * ratio
for (x out = x start ; x out < x end ; ++ x out)
{
  put pixel (x out + xc, y + yc, 1) ;
  put pixel (x out + xc, -y + yc, 1) ;
  put pixel (-x out + xc, -y + yc, 1) ;
  put pixel (-x out + xc, y + yc, 1) ;
}

(y out = y start ; y out < y end ; ++y out)
{
  put pixel (y out + xc, x + yc, 1) ;
  put pixel (y out + xc, -x + yc, 1) ;
  put pixel (-y out + xc, -x + yc, 2) ;
  put pixel (-y out + xc, x + yc, 1) ;
}

```

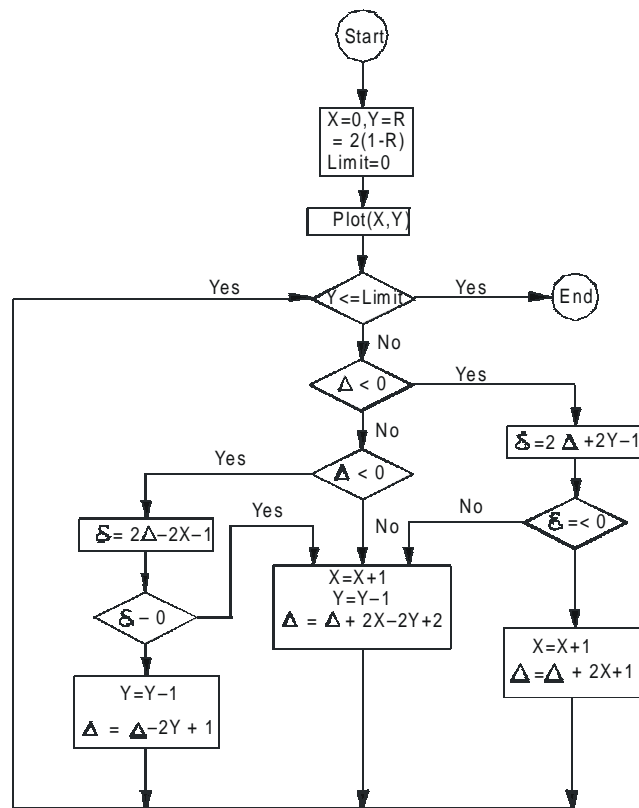


Fig. 3.5 Flow Chart to Determine Pixel Values

### 3.5.2 EXAMPLE OF BRESENHAM'S ALGORITHM

Consider a circle with centre at the origin and radius equal to 10 units. Because of symmetry only the first octant is considered here.

```

X = 0
Y = 10

i = 2 (1-10) = -18
LIMIT = 0
PLOT (0, 10)
Y1 > LIMIT CONTINUE
    i < 0 GOTO 2
2    = 2 (-18) + 2 (10) -1 = -17 < 0 GOTO 10
10 X = 0 + 1 = 1

    i = -17 + 2 + 1 = -14
    GOTO 1
1    PLOT (1, 10)
    Yi > LIMIT CONTINUE

        i < 0
        = 2 (-14) + 2 (10) -1
        = -9 < 0 GOTO 10
    X = 1 + 1
    i = -14 + 2 (2) + 1
    = -9

    GOTO 1
    PLOT (2, 10)

```

The procedure is to be continued till the required point is reached. The results are given in Table 3.3 and are plotted in Fig. 3.6.

**Table 3.3 Pixel Values for Circle**

<i>i</i>		<i>X</i>	<i>Y</i>	<i>Plot</i>
-18		0	10	0, 10
-15	-17	1	10	1, 10
-10	-11	2	10	2, 10
-3	-1	3	10	3, 10
-14	13	4	9	4, 9
-3	-11	5	9	5, 9
-3	3	6	8	6, 8
-1	5	7	7	7, 7

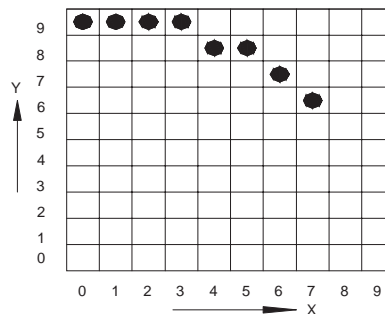


Fig. 3.6 Plot of First Octant of a Circle

### 3.6 ELLIPSE

The ellipse is a variation of a circle. Stretching a circle in one direction produces an ellipse. The polar equations for an ellipse with centre at  $X_C$ ,  $Y_C$  are:

$$X = X_C + a * \cos(\theta)$$

$$Y = Y_C + b * \sin(\theta)$$

The above equations can be used to plot an ellipse in a manner similar to that of generating a circle.

### 3.7 TRANSFORMATION IN GRAPHICS

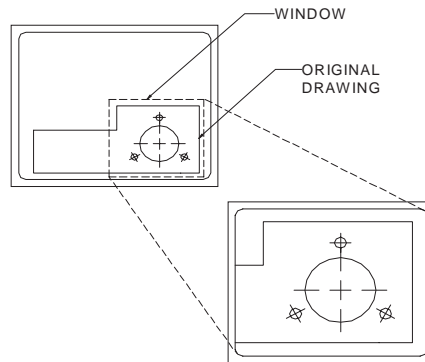
Geometric transformations provide a means by which an image can be enlarged in size, or reduced, rotated, or moved. These changes are brought about by changing the co-ordinates of the picture to a new set of values depending upon the requirements.

### 3.8 CO-ORDINATE SYSTEMS USED IN GRAPHICS AND WINDOWING

Transformations can be carried out either in 2-dimensions or in 3-dimensions. The theory of two-dimensional transformations is discussed first in this chapter. This is then extended to three dimensions.

When a design package is initiated, the display will have a set of co-ordinate values. These are called default co-ordinates. A user co-ordinate system is one in which the designer can specify his own co-ordinates for a specific design application. These screen independent co-ordinates can have large or small numeric range, or even negative values, so that the model can be represented in a natural way. It may, however, happen that the picture is too crowded with several features to be viewed clearly on the display screen. Therefore, the designer may want to view only a portion of the image, enclosed in a rectangular region called a window. Different parts of the drawing can thus be selected for viewing by placing the windows. Portions inside the window can be enlarged, reduced or edited depending upon the requirements. Figure 3.7 shows the use of windowing to enlarge the picture.

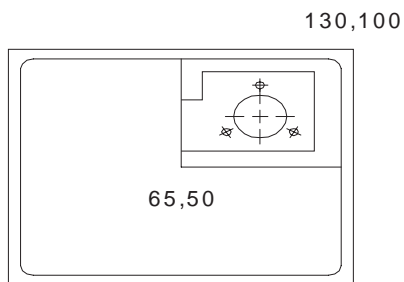




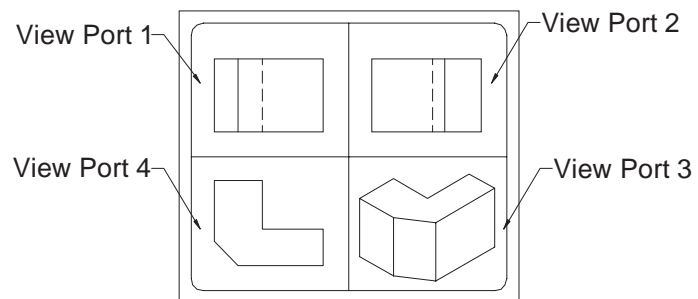
**Fig. 3.7 Use of Window to Enlarge a Portion of the Drawing**

### 3.9 VIEW PORT

It may be sometimes desirable to display different portions or views of the drawing in different regions of the screen. A portion of the screen where the contents of the window are displayed is called a view port. Let the screen size be  $X = 0$  to  $200$  and  $Y = 0$  to  $130$ . A view port can be defined by the co-ordinates say  $X1 = 65$ ,  $X2 = 130$ ,  $Y1 = 50$  and  $Y2 = 100$ . If we use the same window as in Fig. 3.7, the definition of this view port will display the image in the right hand top quarter of the screen (Fig. 3.8) choosing different view ports multiple views can be placed on the screen. Fig. 3.9 shows four views of a component displayed using view port commands.



**Fig. 3.8 View Port**



**Fig. 3.9 Use of Multiple View Ports**

### 3.10 2-D TRANSFORMATIONS

In computer graphics, drawings are created by a series of primitives which are represented by the co-ordinates of their end points. Certain changes in these drawings can be made by performing some mathematical operations on these co-ordinates. The basic transformations are scaling, translation and rotation.

### 3.10.1 SCALING

Changing the dimensions of window and view port, it is possible to alter the size of drawings. This technique is not satisfactory in all cases. A drawing can be made bigger by increasing the distance between the points of the drawing. In general, this can be done by multiplying the co-ordinates of the drawing by an enlargement or reduction factor called scaling factor, and the operation is called scaling. Referring to Fig. 3.10, P1 (30, 20) represents a point in the XY plane. In matrix form, P1 can be represented as:

$$P1 = [30, 20]$$

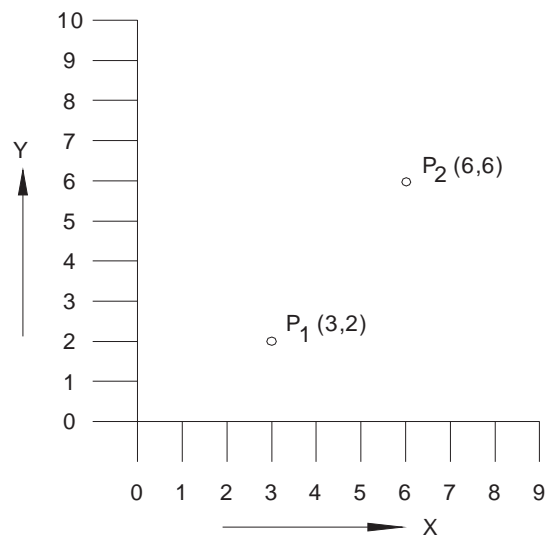
If we multiply this by a matrix

$$\begin{bmatrix} 2 & 0 \\ 0 & 3 \end{bmatrix}$$

we get a new point P2 (60, 60). The matrix is called the scaling matrix. In general, the scaling matrix can be represented as:

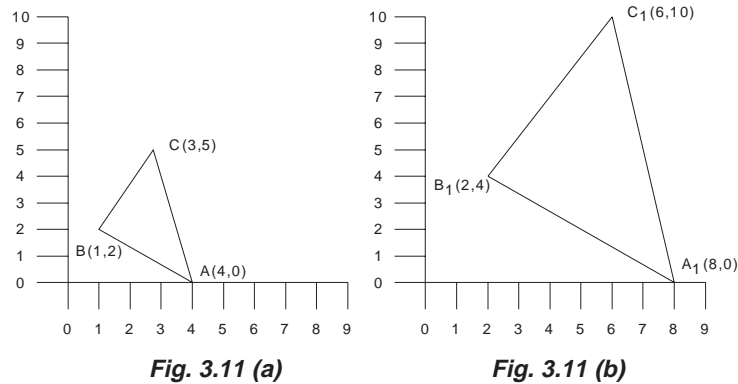
$$\begin{bmatrix} S_x & 0 \\ 0 & S_y \end{bmatrix}$$

where  $S_x$  and  $S_y$  are scaling factors in X and Y directions.



**Fig. 3.10 Scaling a Point**

An example of scaling in the case of a triangle is shown in Fig. 3.11. Fig. 3.11 (a) shows the original picture before scaling. Fig. 3.11 (b) shows the triangle after the co-ordinates are multiplied by the scaling matrix.

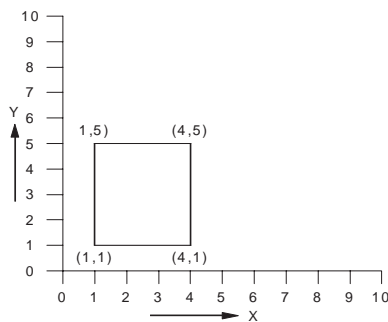


**Fig. 3.11 Scaling a Triangle**

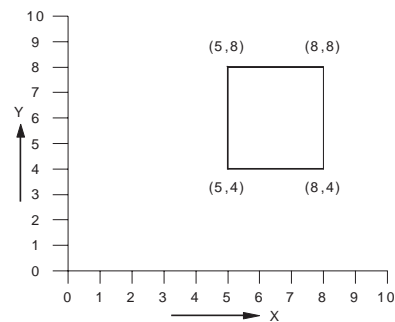
### 3.10.2 TRANSLATION

Moving drawing or model across the screen is called translation. This is accomplished by adding to the co-ordinates of each corner point the distance through which the drawing is to be moved (translated). Fig. 3.12 shows a rectangle (Fig. 3.12 (a)) being moved to a new position (Fig. 3.12 (b)) by adding 40 units to X co-ordinate values and 30 units to Y co-ordinate values. In general, in order to translate drawing by  $(T_x, T_y)$  every point X, Y will be replaced by a point X<sub>1</sub>, Y<sub>1</sub> where

$$\begin{aligned} X_1 &= X + T_x \\ Y &= Y + T_y \end{aligned}$$



**Fig. 3.12(a) Original Rectangle**



**Fig. 3.12 (b) Rectangle After Translation**

### 3.10.3 ROTATION

Another useful transformation is the rotation of a drawing about a pivot point. Consider Fig. 3.13. Point P<sub>1</sub> (40, 20) can be seen being rotated about the origin through an angle,  $\theta = 45^\circ$ , in the anti-clockwise direction to position P<sub>2</sub>. The co-ordinates of P<sub>2</sub> can be obtained by multiplying the co-ordinates of P<sub>1</sub> by the matrix:

$$\begin{bmatrix} \cos \theta & \sin \theta \\ -\sin \theta & \cos \theta \end{bmatrix}$$

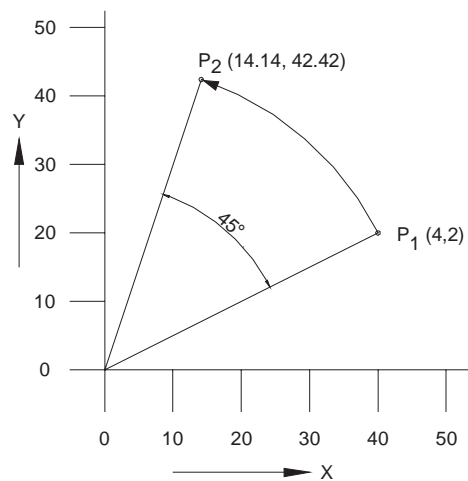
The new co-ordinates are

$$= [40 \quad 20] \begin{bmatrix} \cos 45^\circ & \sin 45^\circ \\ -\sin 45^\circ & \cos 45^\circ \end{bmatrix}$$

$$= [40 \quad 20] \begin{bmatrix} 0.707 & 0.707 \\ -0.707 & 0.707 \end{bmatrix}$$

$$= [14.14 \quad 42.42]$$

For rotating drawings in anticlockwise direction positive angles are used.



**Fig. 3.13 Rotation**

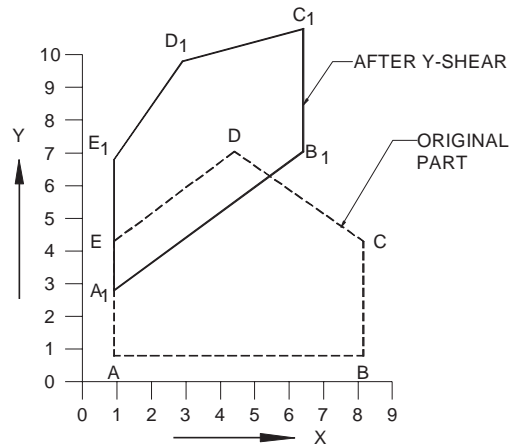
### 3.10.4 SHEARING

A shearing transformation produces distortion of an object or an entire image. There are two types of shears: X-shear and Y-shear. A Y-shear transforms the point  $(X, Y)$  to the point  $(X_1, Y_1)$  by a factor  $Sh_1$ , where

$$X_1 = X$$

$$Y_1 = Sh_1 \cdot X + Y$$

Fig. 3.14 shows Y shear applied to a drawing.



**Fig. 3.14 Shearing**

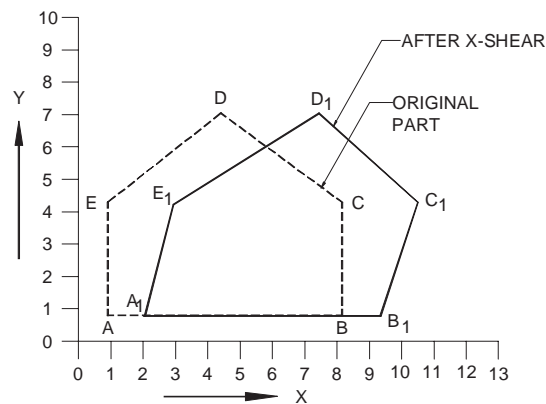
An X-shear transforms the point  $(X, Y)$  to  $(X_1, Y_1)$ , where

$$X_1 = X + Sh_2 \cdot Y$$

$$Y_1 = Y$$

$Sh_2$  is the shear factor.

Fig. 3.15 shows the effect of X-shear.



**Fig. 3.15 X-Shear**

### 3.11 HOMOGENEOUS TRANSFORMATIONS

Each of the above transformations with the exception of translation can be represented as a row vector  $X, Y$  and a  $2 \times 2$  matrix. However, all the four transformations discussed above can be represented as a product of a  $1 \times 3$  row vector and an appropriate  $3 \times 3$  matrix. The conversion of a two-dimensional co-ordinate pair  $(X, Y)$  into a 3-dimensional vector can be achieved by representing the point as  $[X \ Y \ 1]$ . After multiplying this vector

by a 3 X 3 matrix, another homogeneous row vector is obtained  $[X1 \ Y1 \ 1]$ . The first two terms in this vector are the co-ordinate pair which is the transform of  $(X, Y)$ . This three dimensional representation of a two dimensional plane is called homogeneous co-ordinates and the transformation using the homogeneous co-ordinates is called homogeneous transformation. The matrix representations of the four basic transformations are given below.

Translation:

$$[X1 \ Y1 \ 1] = [X \ Y \ 1] \begin{bmatrix} 1 & 0 & 0 \\ 0 & 1 & 0 \\ T_x & T_y & 1 \end{bmatrix}$$

Rotation

$$[X1 \ Y1 \ 1] = [X \ Y \ 1] \begin{bmatrix} \cos\theta & \sin\theta & 0 \\ -\sin\theta & \cos\theta & 0 \\ 0 & 0 & 1 \end{bmatrix}$$

Scaling

$$[X1 \ Y1 \ 1] = [X \ Y \ 1] \begin{bmatrix} S_x & 0 & 0 \\ 0 & S_y & 0 \\ 0 & 0 & 1 \end{bmatrix}$$

X-shear

$$[X1 \ Y1 \ 1] = [X \ Y \ 1] \begin{bmatrix} 1 & 0 & 0 \\ Sh_x & 0 & 0 \\ 0 & 0 & 1 \end{bmatrix}$$

Y-shear

$$[X1 \ Y1 \ 1] = [X \ Y \ 1] \begin{bmatrix} 1 & Sh_y & 0 \\ 0 & 1 & 0 \\ 0 & 0 & 1 \end{bmatrix}$$

### 3.12 COMBINATION TRANSFORMATIONS

Sequences of transformations can be combined into a single transformation using the concatenation process. For example, consider the rotation of a line about an arbitrary point. Line AB is to be rotated through  $45^\circ$  in anticlockwise direction about point A (Fig 3.16(a)). Fig. 3.16(b) shows an inverse translation of AB to  $A_1B_1$ .  $A_1B_1$  is then rotated through  $45^\circ$  to  $A_2B_2$ . The line  $A_2B_2$  is then translated to  $A_3B_3$ .

The respective transformation matrices are:

$$\begin{bmatrix} 1 & 0 & 0 \\ 0 & 1 & 0 \\ -T_x & -T_y & 1 \end{bmatrix}$$

$$\begin{bmatrix} \cos\theta & \sin\theta & 0 \\ -\sin\theta & \cos\theta & 0 \\ 0 & 0 & 1 \end{bmatrix}$$

and

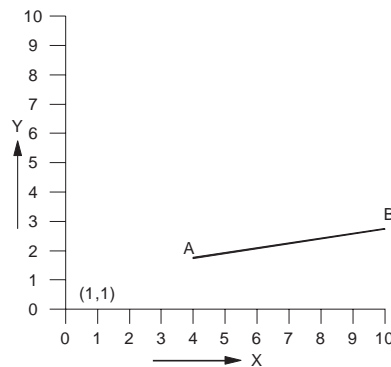
$$\begin{bmatrix} 1 & 0 & 0 \\ 0 & 1 & 0 \\ T_x & T_y & 1 \end{bmatrix}$$

The same effect can be achieved using the concatenated (combined) matrix given below:

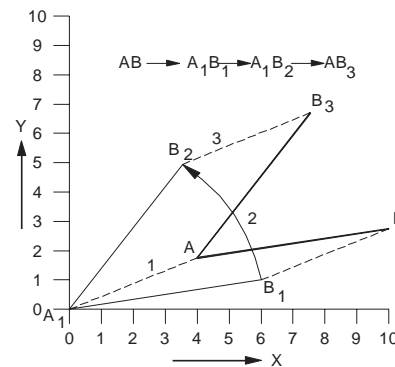
$$[X_1 \ Y_1 \ 1] = [X \ Y \ 1] \begin{bmatrix} 1 & 0 & 0 \\ 0 & 1 & 0 \\ -T_x & -T_y & 1 \end{bmatrix} \begin{bmatrix} \cos\theta & \sin\theta & 0 \\ -\sin\theta & \cos\theta & 0 \\ 0 & 0 & 1 \end{bmatrix} X$$

$$\begin{bmatrix} 1 & 0 & 0 \\ 0 & 1 & 0 \\ T_x & T_y & 1 \end{bmatrix}$$

Since matrix operations are not commutative, care must be taken to preserve the order in which they are performed while combining the matrices.



**Fig. 3.16 (a)**



**Fig. 3.16 (b)**

**Fig. 3.16 Rotation about an Arbitrary Point**

### 3.13 CLIPPING

Clipping is the process of determining the visible portions of a drawing lying within a window. In clipping each graphic element of the display is examined to determine whether or not it is completely inside the window, completely outside the window or crosses a window boundary. Portions outside the boundary are not drawn. If the element of a drawing crosses the boundary the point of inter-section is determined and only portions which lie inside are drawn. Readers are advised to refer to books on computer graphics for typical clipping algorithms like Cohen-Sutherland clipping algorithm. Fig. 3.17 shows an example of clipping.

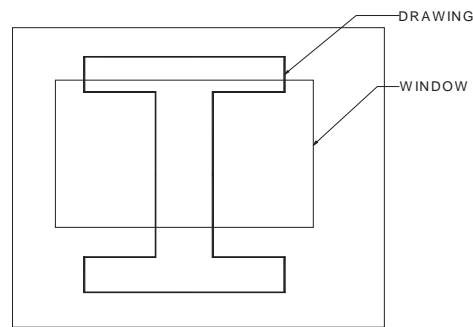


Fig. 3.17 Example of Clipping

### 3.14 3-DIMENSIONAL TRANSFORMATIONS

It is often necessary to display objects in 3-D on the graphics screen. The transformation matrices developed for 2-dimensions can be extended to 3-D.

i. **Scaling:** The scaling matrix in 3-D is:

$$\begin{bmatrix} S_x & 0 & 0 & 0 \\ 0 & S_y & 0 & 0 \\ 0 & 0 & S_z & 0 \\ 0 & 0 & 0 & 1 \end{bmatrix}$$

ii. **Translation:** The translation matrix is:

$$\begin{bmatrix} 1 & 0 & 0 & 0 \\ 0 & 1 & 0 & 0 \\ 0 & 0 & 1 & 0 \\ T_x & T_y & T_z & 1 \end{bmatrix}$$

iii. **Rotation:** Rotation in 3-D can be about X - , Y - or Z axis.



Rotation about Z axis:  $R_z = \begin{bmatrix} \cos\theta & \sin\theta & 0 & 0 \\ -\sin\theta & \cos\theta & 0 & 0 \\ 0 & 0 & 1 & 0 \\ 0 & 0 & 0 & 1 \end{bmatrix}$

Similarly  $R_x = \begin{bmatrix} 1 & 0 & 0 & 0 \\ 0 & \cos\phi & -\sin\phi & 0 \\ 0 & \sin\phi & \cos\phi & 0 \\ 0 & 0 & 0 & 1 \end{bmatrix}$

similarly

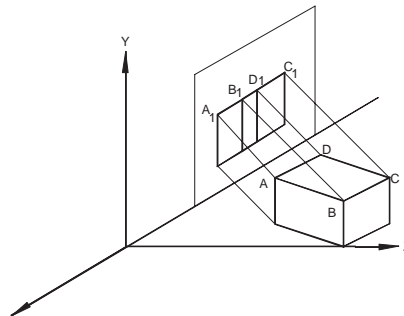
and  $R_y = \begin{bmatrix} \cos\phi & 0 & \sin\phi & 0 \\ 0 & 1 & 0 & 0 \\ -\sin\phi & 0 & \cos\phi & 0 \\ 0 & 0 & 0 & 1 \end{bmatrix}$

### 3.15 PROJECTIONS

In drawing practice, a 3-dimensional object is represented on a plane paper. Similarly in computer graphics a 3-dimensional object is viewed on a 2-dimensional display. A projection is a transformation that performs this conversion. Three types of projections are commonly used in engineering practice: parallel, perspective and isometric.

#### 3.15.1 PARALLEL (ORTHOGONAL) PROJECTION

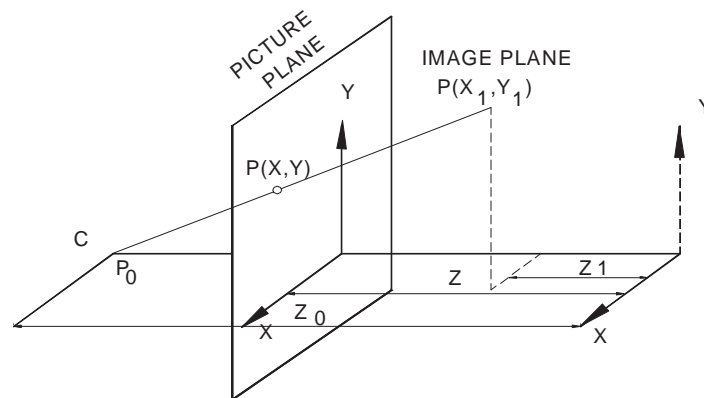
This is the simplest of the projection methods. Fig. 3.18 shows the projection of a cube on to a projection plane. The projectors, which are lines passing through the corners of the object are all parallel to each other. It is only necessary to project the end points of a line in 3-D and then join these projected points. This speeds up the transformation process. However a major disadvantage of parallel projection is lack of depth information.



**Fig. 3.18 Parallel Projection of Cube**

### 3.15.2 PERSPECTIVE PROJECTION

The perspective projection enhances the realism of displayed image by providing the viewer with a sense of depth. Portions of the object farther away from the viewer are drawn smaller than those in the foreground. This is more realistic as it is the way we see an object. In perspective projection the projections connect the eye with every point of the object and therefore all projections converge to the eye.



**Fig. 3.19 Central Projection**

As the display screen is a two-dimensional space, we cannot display three-dimensional objects but only their projections. Computationally, projection transformations are in general quite expensive. Since the generation of a perspective view of a given object may require the projection transformation of a considerable number of points, the projection applied is usually restricted to the central projection and sometimes to even simpler parallel or orthographic projection in order to keep the execution time for the generation of a perspective view within reasonable limits.

Figure 3.19 explains the central projection as it is usually applied in computer graphics. The problem is to determine the projection of an object point, located somewhere in a three-dimensional space, onto a plane in that space, called the image plane. This projection is called the image point of the corresponding object point. In a central projection, The center of projection, also called the viewpoint, is located on one of the axes of the three-dimensional orthogonal co-ordinate system. In Figure 3.19 the viewpoint is arbitrarily located on the Z-axis. This fact can also be expressed by saying that the optical axis is aligned with the Z-axis of the co-ordinate system. The image plane is perpendicular to the optical axis; i.e., in figure 3.19 it is parallel to the xy-plane of the co-ordinate system. This fact accounts for the simplicity of a central projection.

Let the co-ordinates in the two-dimensional co-ordinate system of the image plane, which we may call the image co-ordinate system, be denoted by X and Y. Let the distance of the image plane to the origin of the spatial co-ordinate system be denoted by Z and the distance of the viewpoint to the origin of the co-ordinate system by  $Z_0$ .

Then it follows from an elementary theorem of geometry that

$$X = \frac{Z_0 - Z}{Z_0 - Z_1} X_1$$

$$Y = \frac{Z_0 - Z}{Z_0 - Z_1} Y_1$$

A further simplification can be obtained by setting  $Z_1 = 0$ . i.e., by moving into the XY plane of the spatial co-ordinate system. Then we have

$$X = \frac{Z_0 - Z}{Z_0} X_1$$

$$Y = \frac{Z_0 - Z}{Z_0} Y_1$$

For even further simplification, we may move the viewpoint C toward infinity. With  $Z \rightarrow \infty$ , and we have the trivial solution

$$X = X_1 \text{ and } Y = Y_1$$

This projection is called orthographic. The orthographic projection is a special form of the parallel projection by which parallel lines of the three-dimensional object are transformed into parallel lines of its image.

### 3.15.3 ISOMETRIC PROJECTION

In isometric projection the three orthogonal edges of an object are inclined equally to the projection plane. Because of the relative ease of projection and the ability to give 3-D perception, isometric projection is widely used in computer aided design.

In computer aided design the co-ordinates of the drawing are available in their natural co-ordinate system. These are transformed suitably to enable the viewer different views or rotate the object in such away that all the faces of the object are made visible continuously. There are several uses for this technique in product design. Hence good design packages incorporate several viewing transformation techniques. The viewing parameters depend upon the system graphics standard followed in developing the graphics package. The algorithms for these viewing transformations are available in literature.

### 3.16 SCAN CONVERSION

In order to display rasterized image using video technology it is necessary to organize the picture into the precise pattern required by the video display. This is called scan conversion. The display information must be organized and presented in the scan line order i.e., from top to bottom and from left to right. There are several techniques of scan conversion.

- i. Real time scan conversion
- ii. Run-length encoding
- iii. Cell organization
- iv. Frame buffer memory

### 3.16.1 REAL TIME SCAN CONVERSION

In this technique the picture is randomly represented in terms of visual attributes like color, shade and intensity, and geometrical properties like X, Y co-ordinates, slopes and text, which are ordered in Y. The scan conversion program scans through this information and calculates the intensity of each pixel on the screen.

Consider Fig. 3.20. The figure consists of four lines (AB, BC, AD and CD). Three scan lines 1, 2 and 3 are also shown in the figure. The active edge list for this figure is shown in Table.3.4.

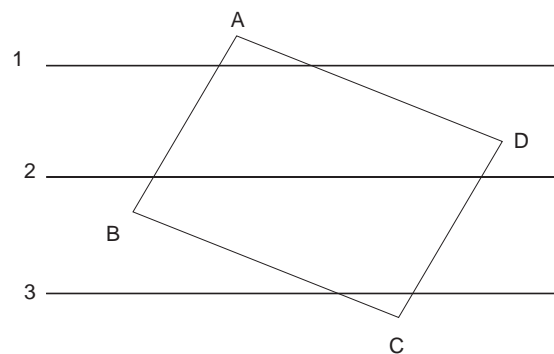


Fig. 3.20 Active Edge List

Table 3.4 Active Edge List for Fig. 3.20

Scan line	1	2	3
Outside edge list	AD	AD AB	AD AB DC
	DC	DC BC BC	BC

Thus for scan line 3, all the edges above the scan line are also included in the active list.

### 3.16.2 RUN LENGTH ENCODING

In run length encoding scheme the number of pixels of same intensity and color in a given scan line is specified. In the simplest case the encoded data will show the intensity and run length. For example, suppose we have a pixel arrangement in a scan line as shown in Fig. 3.21.



*Fig. 3.21 Pixels in the Scan Line*

For the scan line of Fig 3.21, the encoding is shown in Fig. 3.22. For the first four pixels in the scan line the line intensity is zero. Intensity is one for the next pixel, zero for next two pixels, and one for the next pixel and so on.

Run length encoding has the advantage of large data compression. Its disadvantage is that since the run lengths are stored sequentially, addition or deletion of lines is difficult.

0	4	1	1	0	2	1	1	0	1	1	2	0	1	0	1	1	2	0	1
---	---	---	---	---	---	---	---	---	---	---	---	---	---	---	---	---	---	---	---

*Fig. 3.22 Run Length Encoding of Scan Line Shown in Fig. 3.21*

### 3.16.3 CELL ENCODING

Run length encoding stores a picture sequentially line by line. In contrast cell encoding considers representation of picture information by dividing the display area into cells of suitable sizes. For example, a display area of  $512 \times 512$  can be divided into 4096 cells of 64 pixels. In the case of drawings, combinations of these adjacent cells can be used to construct complete lines.

### 3.16.4 FRAME BUFFERS

A common implementation of frame buffer is a random access semiconductor memory. Frame buffers can also be implemented using shift registers. Each shift register contributes one pixel in a horizontal scan line. Fig. 3.23 shows a shift register implementation of frame buffer. Shift register frame buffer memory has the disadvantage of low levels of interactivity.

For better graphics performance the usual practice is to add a graphics processor with a separate frame buffer memory. The system performance can be improved by this architecture as it meets the update requirements of the frame buffer.

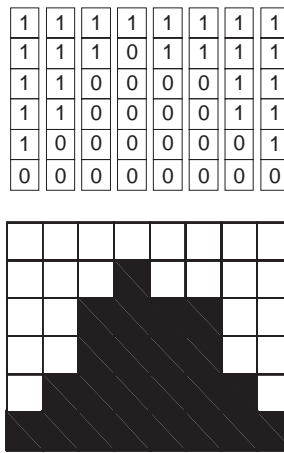


Fig. 3.23 Shift Register Implementation of Frame Buffer

### 3.17 RENDERING

Rendering is a general term describing the overall process of representation of a 3-D object to a shaded 2-D projection on the screen of the computer. This involves a number of processes:

- i. Generation of a data structure for polygon models that will contain the information required for the shading process.
- ii. Applying transformations
- iii. Scan converting polygons
- iv. Hidden surface removal
- v. Shading individual pixels.

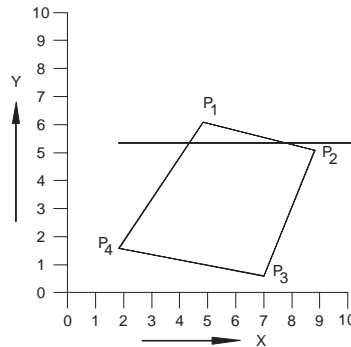
### 3.18 RASTERIZING POLYGONS

Rasterizing a line was discussed earlier in this chapter. Filling a polygon means finding pixel co-ordinates of interior points and assigning to these a value calculated using one of the incremental shading schemes. This requires the construction of an edge list for each polygon. There are two approaches to solid area scan conversion of polygons. They are scan conversion and seed filling.

#### 3.18.1 SCAN CONVERTING POLYGONS

A scan line intersects a polygon at one or more points. The intersection divides the scan line into a number of regions. Referring to Fig. 3.24, P1-P2-P3-P4 is a polygon. It has a vertex list of P1P2P3P4 and an edge list of P1P2, P2P3, P3P4 and P4P1. The intersections are at pixels 4 and 8 along the scan line n. In determining the intensity of shade or color, the intersections are considered in pairs. For intervals between pairs of intersections, the color

will be that of the background. For the scan line considered, from pixel 4 to 8, the color is that of the polygon and beyond 8 the color is the background again. Several algorithms are available to create ordered edge lists. These take into consideration the intersection of the scan line with the vertices of the polygon also.



**Fig. 3.24 Scan Converting Polygons**

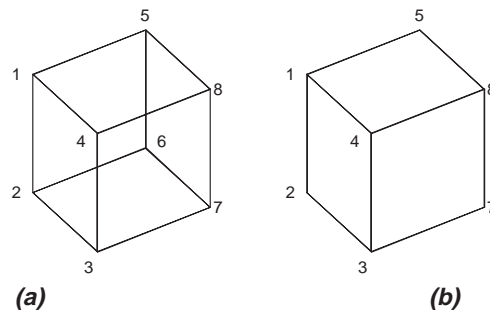
### 3.18.2. SEED FILL ALGORITHM

The scan line algorithm fills the polygon in the scan line order. The seed fill algorithm is designed on the assumption that at least one pixel interior to a polygon is known. Interior - or boundary - defined regions can be classified into 4 - connected or 8 - connected. Algorithms can be designed to fill both the regions. An 8-connected algorithm, apart from left, right, up and down direction, gives four more additional diagonal directions.

More efficient algorithms use a combination of scan line and seed fill approaches.

### 3.19 HIDDEN SURFACE REMOVAL

One of the difficult problems in computer graphics is the removal of hidden surfaces from the images of solid objects. In Fig. 3.25 (a) an opaque cube is shown in wire frame representation. Edges 15, 48, 37, 14, 12,23,58 and 87 are visible whereas edges 56, 67 and 26 are not visible. Correspondingly, surfaces 1265, 2673 and 5678 are not visible since the object is opaque. The actual representation of the cube must be as shown in Fig. 3.25 (b).



**Fig. 3.25 Hidden Surface Removal**

There are a number of algorithms available for removal of hidden lines and hidden surfaces. Table 3.5 gives a list of algorithms for hidden line removal and hidden surface removal.

**Table 3.5 Algorithms for Hidden Line and Hidden Surface**

<i>Hidden line removal</i>	<i>Hidden surface removal</i>
Floating horizon	Blinn-Whitted
Image space	Catmull subdivision
List priority	Clark
Object space	Lane Carpenter
Ray tracing	Scan line
Roberts Warnock	Image space
	List priority
	Newell -Newell-Sancha
	Schumacher
	Object space
	Ray tracing
	Roberts Algorithm
	Scan line Z-buffer
	Warnock
	Watkins
	Weiler Atherton

There are two popular approaches to hidden surface removal. These are scan line based systems and Z-buffer based systems. Other important approaches are area subdivision and depth list schemes.

### 3.19.1 Z-BUFFER ALGORITHM

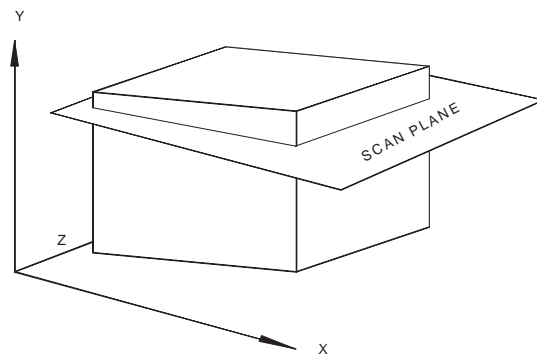
This scheme was developed by Catmull using Sutherland's classification scheme. In this technique, pixels interior to a polygon are shaded and their depth is evaluated by interpolation from Z-values of the polygon vertices after the viewing transformation has been applied. For every pixel, (X, Y) values are the pixel co-ordinates and Z value is the viewing space depth. For each interior polygon point a search is carried out to determine the minimum Z value. This search is conveniently implemented using a Z-buffer that holds for a current point (X, Y) the smallest Z value so far encountered. The Z-buffer algorithm has the advantage of simplicity. It handles scenes of any complexity. There is also no computation required for depth sort. The storage space required, however is large. This could be reduced by pre-processing, so that polygons nearest the viewpoint are processed first.



### 3.19.2 SCAN LINE Z-BUFFER ALGORITHM

This is a special case of Z-buffer algorithm. In this algorithm for each scan line the frame buffer is initialized to the back ground and Z buffer to the minimum Z. The intersection of the scan line with the two dimensional projection of each polygon is found. The depth of each pixel on the scan line between each pair of the intersection is determined. If the pixel depth is greater than that in the Z-buffer then this line segment is currently visible.

A spanning scan line algorithm, instead of solving the hidden surface removal on a pixel-by-pixel basis using incremental Z calculation, uses spans along the scan line over which there is no depth conflict. Consider the three dimensional screen space shown in Fig. 3.26. A scan line algorithm moves a scan line plane down the Y-axis. This plane, parallel to the XOZ plane, intersects the objects in the scene and reduces the hidden surface problem to a 2-D space. The line segments obtained through the intersection are then analyzed to detect hidden surfaces. This is done by considering the spans which form part of a line segment that is contained between edge intersections of all active polygons.



*Fig. 3.26 Spanning Scan line algorithm*

### 3.20 ANTI ALIASING

Aliasing in computer graphics manifests in several ways. The computer generated image will have jagged edges and incorrectly rendered fine detail or texture. Objects smaller than the size of the pixel may be lost while displaying. Anti aliasing is the technique adopted to solve these problems. One technique is to increase the sampling rate by increasing the resolution of the raster. Another method is to calculate the raster at higher resolution and display it at lower resolution by averaging the pixel and attribute at the lower resolution. Three techniques are described briefly below.

### 3.20.1 SUPER SAMPLING OR POST FILTERING

This method is a three-stage process. The stages are :

- i. The image is sampled at  $n$  times the display resolution.
- ii. The sample image is then low pass filtered
- iii. The filtered image is resampled at the device resolution.

This method goes well with Z-buffer technique. However this may cause some blurring. Another disadvantage of this technique is that it is not a suitable method for dealing with small objects. Since the memory requirements when used with Z-buffer technique is large, it is essentially a virtual memory technique.

### 3.20.2 PRE-FILTERING OR AREA SAMPLING

This technique involves performing sub-pixel geometry in the continuous image generation domain and returns for each pixel an intensity which is computed by using the area of visible sub-pixel fragments as weights in an intensity run. Thus this is an area sampling method. Since this method involves considerable amount of computation, several modifications to this algorithm have been developed.

### 3.20.3 STOCHASTIC SAMPLING

This method is a two stage process.

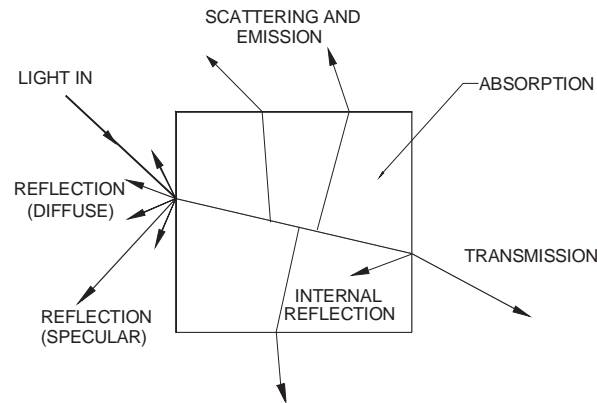
- i. Sample the image using a sampling grid where the position of each sampling point has been subjected to random perturbation.
- ii. Use these sample values with a reconstruction filter to determine the pixel intensities to which the unperturbed sample positions correspond.

The problem with this method is that it is only easily incorporated where the image synthesis uses an incoherent sampling method. Since the method splits the objects into micro polygons, it is suitable of objects consisting of parametric bi-cubic patches.

## 3.21 REFLECTION

Shading is an important element in 3-D computer graphics, as it gives the necessary realism to the representation of the object.

Fig. 3.27 shows what happens when light is incident on a surface. Light gets partly reflected, partly scattered, partly absorbed and partly transmitted. The relative magnitudes of these are influenced by many factors like the opaqueness of the solid, surface texture etc. The intensity and wave length of light reflected from a surface depends on the incident angle, the surface roughness, incident wave length and the electrical properties of the surface. In computer graphics designer can model reflected light and transmitted light.



**Fig. 3.27 Light Incident on a Surface**

Reflected light could be categorized into two types:

- i. **Diffuse reflection:** Diffuse light is scattered in all directions and is responsible for the color of the object. The light is reflected from a surface due to molecular interaction between incident light and the surface material. A yellow object for example, absorbs white light and reflects yellow component of the light. This property is attributed to diffuse reflection. When light from a point source is incident on a solid object, the diffuse reflection depends upon the angle of inclination of the surface with that of the incident beam. More important source of illumination of the objects is ambient light, which is the result of multiple reflections from the walls and other objects in the vicinity and is incident on a surface in all directions.
- ii. **Specular reflection:** A perfectly matt surface scatters light in all directions. Most of the surfaces that we deal with, however, have different levels of glossiness. The specular deflection deals with the reflection of the surface due to glossiness. Consider Fig. 3.28 which shows the reflection of light on a surface. If the surface is perfectly glossy the reflected light is in the direction of R. If the surface becomes more and more matt, the reflection intensity varies as in a profile shown as the shaded area of the figure.

A technique to model reflection from an object based on specular reflection has been proposed by Phong. This model assumes that:

- Light sources are point sources.
- All geometry except the surface normal is ignored.
- Diffuse and specular components are modeled as local components
- The model to simulate the specular term is empirical.
- The color of specular reflection is that of the light source
- The ambient lighting is constant.

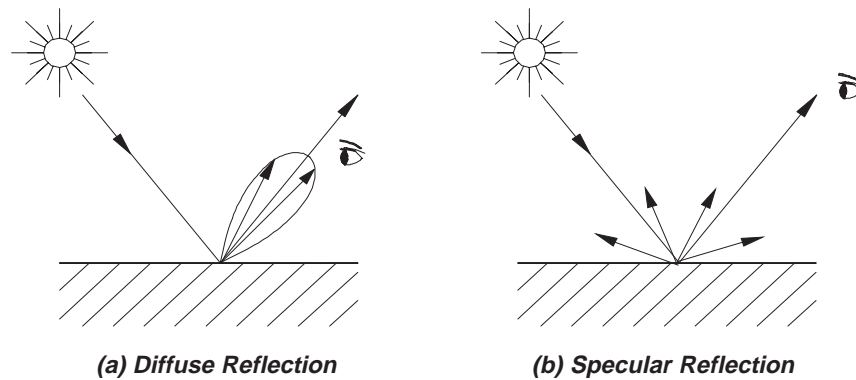


Fig. 3.28 Reflection

### 3.22 SHADING

In simple polygonal mesh models, the surface is represented by constant shading. To introduce more realistic shading, incremental shading is necessary. Two commonly used incremental shading techniques are:

- i. Gouraud Shading
- ii. Phong Shading

#### 3.22.1 GAURAUD SHADING

Gouraud Shading involves bilinear intensity interpolation over a polygon mesh. It is restricted to diffuse component of the reflection model. The technique first calculates the intensity at each vertex, assuming that the light source is at infinity. The intensity of the light reflected over the polygonal surface can then be obtained by integrating the interpolation process with the scan conversion process. The intensities at the edge of each scan line are calculated from the vertex intensities and intensities along the scan line from these.

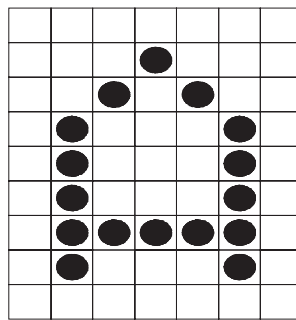
#### 3.22.2 PHONG TECHNIQUE

Phong model overcomes some of the deficiencies of Gouraud technique and incorporates specular reflection. The important feature of the Phong model are :

- i. Vertex normals instead of vertex intensities are calculated by averaging normal vectors of the surface that share the vertex.
- ii. Bilinear interpolation is used for incremental interpolation of points interior to polygons.
- iii. A separate intensity is evaluated for each pixel from the interpolated normals.

### 3.23 GENERATION OF CHARACTERS

Along with the primitives discussed above, strings of characters are to be displayed on drawings to give instruction and information to the user of the drawing. A font can be made of rectangular patterns of dots called raster cells. Fig. 3.29 shows a typical 7×9 raster cell, which may vary from graphic system to graphic system. Each character is then represented by 63 bits. The character generation can be done either through hardware (ROM) or software. Graphics software usually provides means for users to design new fonts.



*Fig. 3.29 Representation of Text*

#### QUESTIONS

1. Using the DDA algorithm described in the text, sketch the pixels for the line drawn from (4,4) to (12, 14).
2. Sketch the pixels for representing a circle with centre at 10, 10 and radius = 5 units.
3. Write a C program to implement Bresenham's circle algorithm.
4. Differentiate between window and view port.
5. Discuss the window and view port features of the CAD software you use.
6. A rectangle has corner co-ordinates (10,20) (40,20), (40,40), (10,40). This rectangle is rotated by 30° anticlockwise about (i) origin and (ii) about the point (40,20). Compute the new co-ordinates in both cases.
7. What is homogeneous transformation?
8. What is concatenated matrix?
9. Briefly describe the different techniques used for scan conversion in Computer Graphics.
10. What is rendering? What are the different stages of rendering an image?
11. Describe an algorithm for the removal of hidden lines.
12. Make a comparative study of hidden surface removal algorithms.
13. What is ant aliasing? Discuss the techniques used for ant aliasing.
14. Discuss the reflection models used in Computer Graphics.
15. Compare the techniques of Phong shading and Gouraud shading.

# CHAPTER

---

# COMPUTER HARDWARE

# 4

*Various types of computers and peripherals are used in CIM. Depending on the size of the organization the type and configuration of computer system vary widely. Computers with special capabilities are recommended for tasks like design and analysis involving very high order of number crunching. This chapter gives a brief account of personal computers and RISC-based design workstations. The commonly used input and output peripherals are also discussed in detail.*

## 4.1 INTRODUCTION

There are two basic components in a computer system used in CIM. They are:

- i. Computer Hardware
- ii. Software

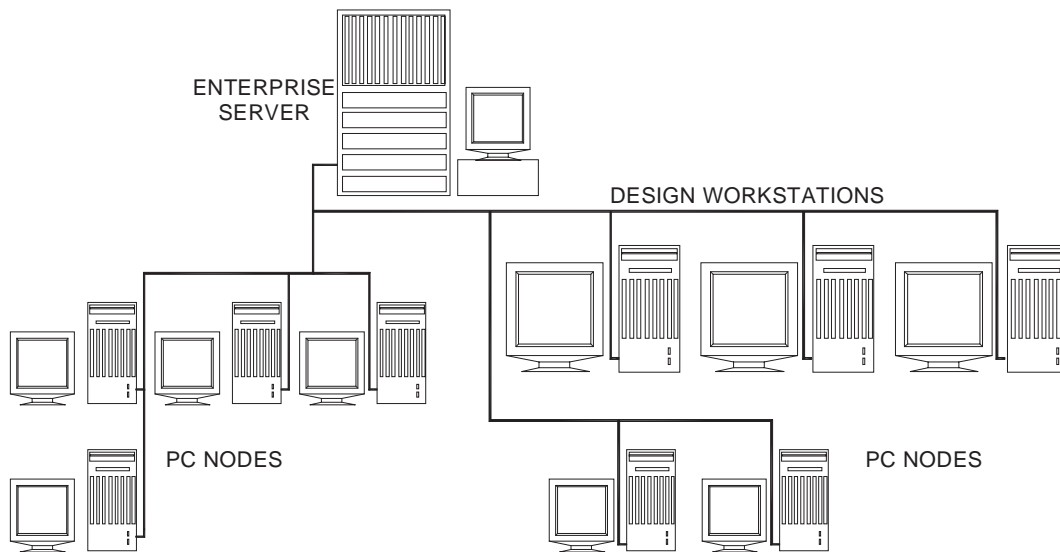
Hardware consists of the various types of computers like personal computers, (PCs), graphics workstations, input devices like mouse, keyboard and digitizer and output devices like plotter and printer.

***Computer software includes:***

- i. The operating system which controls the basic house-keeping operations in a computer.
- ii. Software packages used for conceptual design like Alias and for geometric modeling like solid modeling (Solid Works, Unigraphics, CATIA, Pro/Engineer etc).
- iii. Application software which includes the programs for design analysis, simulation and synthesis, tool design, process planning, enterprise resource planning, PDM, PLM, CNC programming, computer aided inspection etc. These also cover finite element analysis, kinematics analysis, piping design, architecture, PCB design, VLSI design, computational fluid dynamics, expert systems, and several application-specific software packages.

## 4.2 COMPUTER FUNDAMENTALS

Several computer platforms can be used for running the software packages for computer integrated manufacturing. Figure 4.1 shows a typical computer hardware configuration. Usually a powerful server computer and a number of client nodes will be used. The server will be usually a high performance computer, configured to meet the specific operational requirements. The nodes may be a personal computer (PC) or a graphics workstation. The heart of any computer is a microprocessor, which is designed on the basis of the length of the word it can handle. Thus, we have 16 bit, 32 bit and 64 bit microprocessors. The microprocessor carries out arithmetic operations such as addition and subtraction. They also carry out logic operations and alter the sequence in which instructions are carried out depending upon the statements contained in the program. The server stores data and the programs (operating system and application programs) in a part of its primary memory. The remaining part of this memory acts as the working storage and buffer storage for input and output. The contents of this memory are lost when the power is switched off and therefore it is called volatile memory. This memory is called Random Access Memory (RAM) or read-write Memory. Another type of primary memory is the Read Only Memory (ROM) in which some programs stay resident. These programs are permanently stored by the computer manufacturer. The Basic Input/Output System (BIOS) is usually stored in ROM. The nodes may also have adequate memory and processing capabilities depending on the application requirements.



**Fig. 4.1 A Typical Computer Hardware Configuration**

The computer will have a number of mass storage devices built into it. Common types of mass storage devices are floppy discs, hard discs, CD-ROMS and removable

storage devices. Another type of mass storage device is the cartridge tape. Softwares are usually stored in the hard disc and they can be loaded into the primary memory as and when required. In a networked environment, the software is stored in the hard disc of the server and the users can access the software from the different terminals or nodes connected to the server. Hard discs are also used for storing data files, drawing files and other related files. A magnetic tape is used to backup the files so that vital files and information are not lost in the event of a disc failure. Optical discs (CD-ROMs) are widely used nowadays for mass storage.

The display of the programs and drawing is done on the monitor. Several types of monitors or video display units (VDU's) are used as display devices. These include monochrome and color monitors. Super Video Graphics Array (SVGA) is the type of monitor that is widely used on PC's today. A number of input devices are also used, the most popular being the ubiquitous mouse, used for command input, menu selection or pointing on the screen. The keyboard is indispensable for computer operation and is used for command input. A digitizer tablet is also a convenient input device, often used in design. Special input devices are used in laptop computers. Hard copy outputs are usually taken on a plotter. Printed reports and files and print plot drawings can be obtained using a printer.

### 4.3 CLASSIFICATION OF COMPUTERS

Computers are commonly divided into the following types:

- i. Personal Computer or Microcomputers
- ii. Mini Computers
- iii. Mainframes
- iv. Supercomputers

Today the distinction between various types is blurring with advances in microprocessor and microelectronics technologies and processing approaches. Processing speed, accessible memory and cost are the factors used to classify computers. Both processing speed and memory depend on word length.

#### 4.3.1 MICRO COMPUTERS AND PERSONAL COMPUTERS

The personal computers are so named because these were originally developed as a single user desk-top system to increase the productivity of employees. Apple Computer Company is the pioneer in popularizing PC's. IBM introduced their personal computer in the year 1981 and presently IBM or their licensees and Apple Computers (Macintosh series of computers) are the major computer companies who are world leaders in the PC market. Many dedicated microcomputers and super micros optimized for CAD applications are now sold as Windows NT based graphic workstations. The IBM personal computer and the microcomputers that run on the same software (called



compatibles) are very popular with designers. These systems have a powerful CPU, and a fast system clock (a timing signal that co-ordinates the data flow in CPU) of 2.8 GHz or even higher. Most Personal Computers (PC's) are designed around a single processor chip as CPU which will have either 32 or 64 bit word length. Presently the minimum memory quoted on a low end PC (Pentium 4 at 2.8 GHz) is 512 MB. These PC's are based on 32 bit 80586 microprocessors.

Most CAD applications require at least one floppy disc (storage capacity of 1.44 MB) drive and a hard disc drive which storage capacity starting from 40 GB and a CD-ROM drive. The relatively fast access speed of hard disc drive is particularly useful in CIM. Personal computers are also often used as front-end systems of many turnkey CIM systems where more powerful computers are used for data intensive activities like finite element analysis. Several computer companies manufacture IBM PC compatible computers in India. Notable among them are HCL, HP, Wipro, Zenith etc.

Table 4.1 gives the specifications of a typical personal computer.

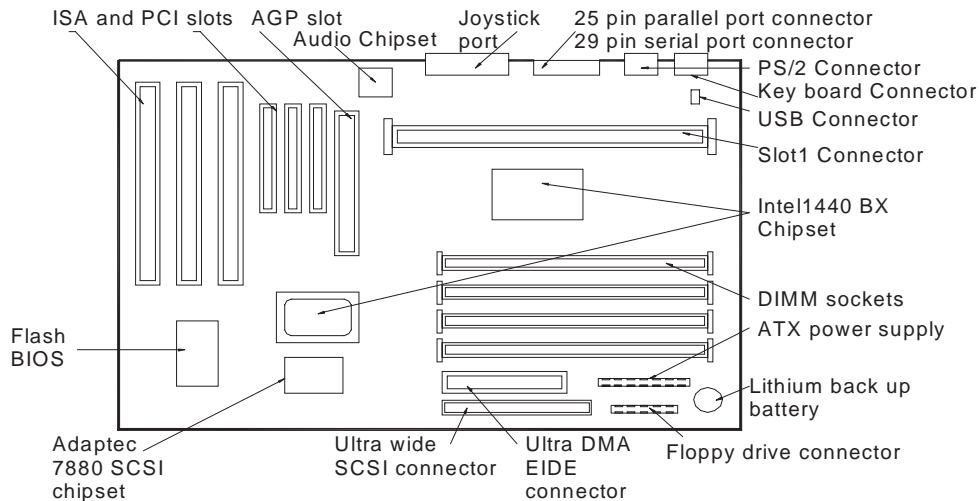
**Table 4.1 Specifications of a Typical PC**

2.8 GHz or faster CPU ATX Motherboard with on board LAN or network adapter 512 MB RAM 40 GB or higher 7200 rpm IDE hard disc drive 1.44 MB 3.5" Floppy disc drive CD- RW 40 X Read, 24X Write, 10 X Rewrite drive 17" LCD Monitor or 17" CRT Monitor On- board sound or Creative Live sound card and amplified speakers PS2 Key Board and Mouse nVidia GeForce video card, on board Intel Extreme Graphics Card
--

#### 4.3.2 OVERVIEW OF PENTIUM PC

The hardware of a Pentium computer consists of the following:

- i. Mother board
- ii. Hard disc/floppy disc controller card
- iii. Graphics adapter card
- iv. Input/Output card
- v. Switch mode power supply
- vi. Floppy disc drive
- vii. Hard disc drive
- viii. CD-ROM drive

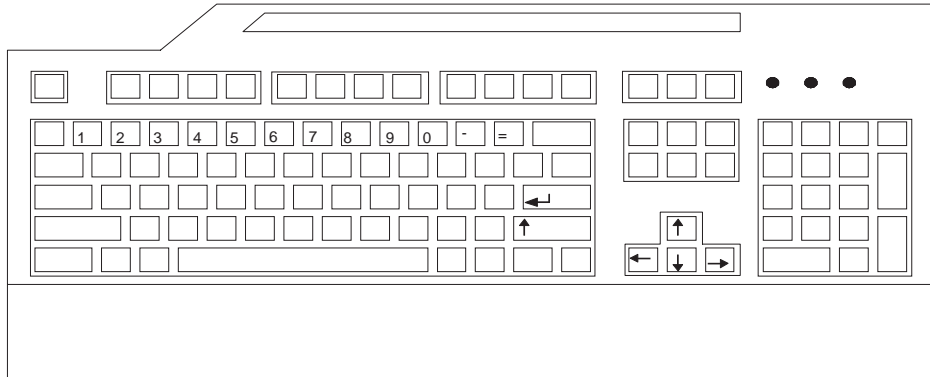


**Fig. 4.2 Layout of the Mother Board of a Pentium Computer**

A Switch Mode Power Supply (SMPS) provides the main board with power and each of the expansion slots up to 1 Ampere per slot. It can sense any spike in the incoming power line voltage and reduce the current to zero thereby protecting the computer circuitry. This also provides the DC voltages necessary for the operation of the computer.

The IBM-PC key board is very versatile because it is entirely “soft”. The programmer has the flexibility to program the keys. Figure 4.3 shows the IBM keyboard. The keyboard contains:

- i. **Alphanumeric keys:** Alphabetic, numeric and symbol keys are arranged in a fashion similar to a typewriter. The shift key is used to shift from capital or lower case or vice versa. “Caps lock” key enable the selection of capital letters when the “Caps lock” condition is on. A separate numeric keypad is provided on the right side.
- ii. **Function keys:** These are soft keys which can be programmed in the software and special functions can be assigned to each one of these keys. These are marked F1 to F12.
- iii. **Cursor control keys:** There are four cursor control keys. These keys are useful in editing programs, controlling cursor in graphics applications etc.
- iv. **Special keys:** These include *control, alt, break, number lock, page up, page down, home, insert, tab, delete, print screen* etc. Function keys, cursor control keys and special keys can be used to improve the productivity of software operation considerably.



**Fig. 4.3 Keyboard**

The operating system of a Pentium PC can be Windows 95, Windows 98, Windows XP or Windows NT. With Windows NT operating system, the personal computer can act as a server for a number of nodes too.

### 4.3.3 MINI COMPUTERS

Mini computers are 64 bit machines and can access more memory. Most turnkey CAD/CAM systems are based on standard mini computers and a substantial amount of third party software is available to perform sophisticated design, analysis and related tasks. Mini computers are very popular with design departments because of their capability to support several interactive terminals, permitting widespread access to engineering and design databases. Minis have perhaps also the best price/performance ratio with a lower initial cost compared to mainframe. Most manufacturers of mini computers offer a range of desk top units to super mini's that rival main frames in speed and memory. This wider range enables firms to progressively use more and more powerful and costly computers using the same software. Mini computers with adequate computing power can be configured as enterprise servers for CIM implementation in small and medium enterprises.

Super minis with a capability of carrying out floating point operations of 500 MFLOPS or more are now being increasingly used in design applications. Another characteristic common to most minicomputers is the virtual memory, a feature which allows execution of large programs in stages which cannot otherwise be handled by the available memory. As a result the computer can run programs requiring storage of considerable data. This facility is essential for data and compute intensive tasks such as finite element analysis (FEA).

### 4.3.4 MAIN FRAME COMPUTER

Main frames have developed from original computers and are typified by their large size and massive memory. Main frames are used today in applications requiring substantial data processing at high speeds. Main frames typically support several terminals and can drive a large number of peripheral units including printers, disc drives, tape drives etc.

Large memory is an essential requirement of main frames as they are frequently used for data intensive operations like design analysis, database management, weather forecasting, traffic and financial operations. Main frames can operate in batch mode or can be used in a time-sharing environment. Main frames are often used to provide processing power after a problem has been set up with a personal computer or mini computer. Main frames are also linked to several smaller computers, which enable the latter to access the large data base of the main frames. This feature is particularly advantageous for design in large design offices where a single data base environment is desirable. The work stations located in the design offices can access the main frame computer of the company for analysis and data, thereby simpler design analysis and drafting are done locally and part of the data intensive design analysis like FEA and solid modeling are carried out at the main frame. For large enterprises, mainframe based computing environment could be a cost effective solution for implementing CIM.

#### 4.3.5 SUPER COMPUTERS

Super computers take advantage of the most recent advancement in electronic circuit design, processing techniques and memory organization to attain computing speeds many times that of main frames. Typically main frames operate at a few megaflops (one megaflop is a million floating point operations per second) whereas supercomputers can have speeds between 20-400 megaflops.

Though these computers are priced very high, because of their high processing speed, the processing cost may be low even in the case of very complex CAD applications which require evaluation of several alternatives or which require several iterations to be carried out. Applications of super computers include modeling and simulation tasks such as solid modeling, kinematical analysis, modal analysis, finite element analysis and computational fluid dynamics. An advantage of supercomputers is the vector processing facility which can drastically increase computing speed. Data pipelining, high speed circuits and large internal memories enable complex design and analysis operations handled conveniently. The performance of a supercomputer can also be achieved by using several processors working in parallel mode.

#### 4.4 DATA COMMUNICATIONS

Computers need to communicate with printers, terminals and other computers. This kind of input/output is typically called data communications, since streams of data are transferred between sources and destinations. This flow must be synchronized. This is typically done under the control of "handshaking" conventions that use either dedicated hardware lines or special character sequences. A simple example of handshaking involves a printer capable of printing only 120 characters per second, but receiving data at 10 times that rate. When the printer's input buffer is full, it sends a busy signal to the data source (by pulling high a line connecting the two), indicating that it cannot accept any more data

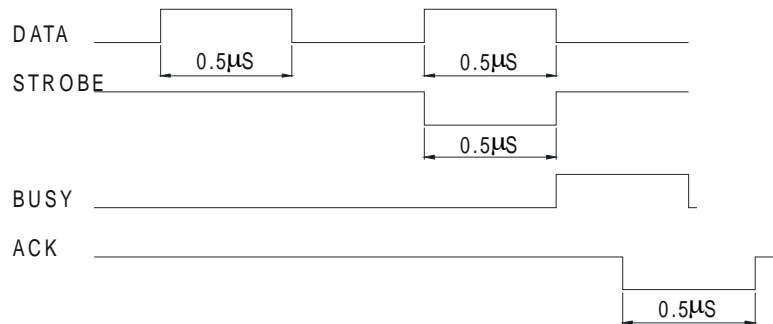
for a while. Later it can accept more data. The “busy” signal here is what is meant by a handshake signal.

Some popular devices for transferring digital data are considered below:

- i. Parallel interface
- ii. Serial RS 232 data link
- iii. IEEE 488 interface bus (also called General Purpose Interface Bus - GPIB)
- iv. USB port
- v. Modems
- vi. Computer to computer communications.

#### 4.4.1 PARALLEL INTERFACE

A parallel interface is one that moves information 8 bits or more at a time. Centronics printer interface is a standard parallel interface. This interface allows data to be transferred to a printer, 8 bits at a time. Fig. 4.4 shows the timing diagram of a Centronics parallel interface. When the computer sends a byte of data to the printer it also sends a pulse down the strobe line. When the printer has read the data byte and is ready to accept another, it acknowledges that fact by sending back a pulse on the ACKNLG Line. IBM PC typically uses the BUSY line for handshaking in a polled mode. Polling means that computer hangs in a little loop, testing the line until the desired condition occurs. As soon as the BUSY Line goes low the PC’s ROM BIOS routine pulses the STROBE line low, telling the printer that a new byte is ready.



**Fig. 4.4 Timing Diagram of Centronics Parallel Interface**

Figure 4.5 shows a Centronics interface connector, pin-numbers as they appear on the 36-pin D-shell Connector.

<b>Name</b>	<b>Adapter Pin Number</b>
Data Strobe (low)	1
Data bit 1 (LSB)	2
Data bit 2	3
Data bit 3	4

*Fig. 4.5 (Contd...)*

<i>Name</i>	<i>Adapter Pin Number</i>
Data bit 4	5
Data bit 5	6
Data bit 6	7
Data bit 7	8
Data bit 8 (LSB)	9
Acknowledge	10
Busy (High)	11
Paper End (High)	12
Select (High)	13
Supply Ground	14
Oscillator Transmit	15
Logical Ground	16
Chassis GND	17
+5 V DC	18

**Fig. 4.5 Centronics Interface Connector**

#### 4.4.2 PARALLEL/SERIAL CONVERSION

When extremely high data rates are not required, the number of wires required for data communication can be reduced substantially by converting the bytes to be transmitted into a serial bit stream. This requires only two wires for bi-directional transmission and a ground line. In a serial bit stream the bits are represented by codes having specific time intervals. The standard asynchronous serial formats used in data communications allocate a time interval known as baud period to each bit (Baud is used to honor a Frenchman named Baudot). The bits are transmitted in separate groups, usually 8 bits long, called characters. The name "character" is used because each group of bits represents one letter of the alphabet when text is being sent. In the standard asynchronous format, the time between characters when no data is being transmitted is indicated by a steady high voltage called a mark. The transmitter tells the receiver that a character is about to start by sending a low-bit known as start bit as shown in Fig. 4.6

0    1    2    3    4    5\*    6\*    7\*    P\*    SP

**Fig. 4.6 Serial Bit Stream Format**

Each character is preceded by a low-level start bit, which synchronizes the receiver and transmitter clocks. The character (5, 6, 7 or 8) bits follow, least significant bit first. The asterisk (\*) indicates optional bits. An optional parity bit and one or more stop (high-level) bits terminate the character. Each bit lasts one baud rate period. Serial receivers and transmitters can be instructed to send or receive as few as 5 or as many as 8 bits per character. After the desired number is sent out an optional parity bit may follow. The parity bit P is useful if the data line is suspected to be noisy for accurate transmission. For even parity

$P=1$  if the number of 1's in the character is odd and  $P=0$ , if the number of 1's is even. At the end of the bits the transmitter inserts one or more high stop bits into the data stream. Because any amount of time can elapse between characters the serial data transmission method is called asynchronous method. The standard baud rates are 110, 150, 300, 600, and 1200. 2400, 4800, 9600 and 19200. Printers and other hard copy devices are usually restricted to low baud rates. Using an 8-bit character with one parity and one stop bit, there is a total of 10 bits. A transmission rate of 300 baud yields 30 characters/sec.

A UART or Universal Asynchronous Receiver Transmitter is a special chip used to simultaneously transmit and receive serial data performing the appropriate parallel/serial conversions and inserting or checking extra bits used to keep serial data synchronized. Bytes sent as 8 bit parallel data to the output data port are converted into a standard format serial bit stream for transmission inside UART. Similarly an incoming serial bit stream is detected by the receiver inside the UART and converted to parallel data.

#### 4.4.3 RS-232 INTERFACE

RS-232 is a serial transmission mode which is a voltage level convention. While the current loop signal can be sent over large distances and can be easily implemented using opto-isolators which prevents wiring mistakes from doing any damage, RS-232 may cause hardware damage if improperly connected. The RS-232 is rated for distances only up to 15 m. This is often used for terminal-modem and terminal-computer connections.

RS-232 is a standard set by Electronic Industries Association and represents 1's by -3 to -20 V and 0's +3 to 20 V. The standard connector is the 25 DB connector. Two IC's are normally used to handle the TTL level signals to RC-232 and vice versa. They, respectively, are 1488 and 1489. Fig. 4.7 shows pin numbers for most commonly used RS-232 lines.

<i>RS-232 Definition</i>	<i>I/O</i>	<i>Data Terminal Equipment (DTE)</i>	<i>Data Communication Equipment (DCE)</i>
Signal Ground		1	1
Transmit Data	0	2	3
Receive Data	1	3	2
Request to send (RTS)	0	4	5
Clear to send (CTS)	1	5	4
Data set ready (DSR)	1	6	20
Chassis Ground		7	7
Carrier Detect		8	8
Data terminal ready	0	20	6

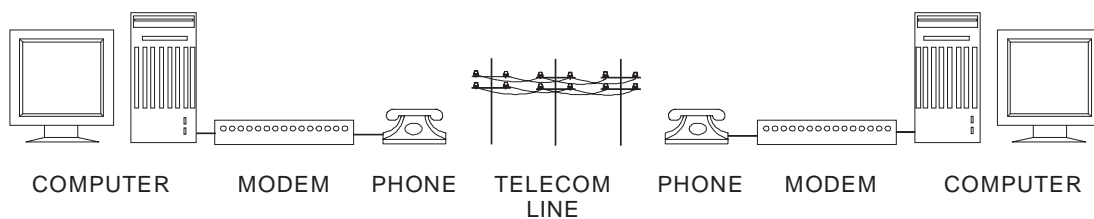
**Fig. 4.7 Pin Numbers For RS 232 Lines**

#### 4.4.4 UNIVERSAL SERIAL BUS

Universal Serial Bus (USB), the most successful interconnecting port in computer history so far is a connectivity specification developed by Intel and other technology leaders. It operates at a speed of 480 Mbps and is used in millions of PCs and mobile devices. USB is now a standard feature in all PCs. Using USB port one can plug standard peripherals as well as devices like portable computing devices, cell phones, digital cameras and MP3 players to PCs. High speed wireless USBs also have a bandwidth of 480 Mbps.

#### 4.4.5 MODEMS

It is often necessary to communicate between workstations at different locations separated by a considerable distance. In such cases an interface element called modem can be used at each end of a data transmission channel. A modem is a **modulation - demodulation** device that converts the discrete stream of digital pulses to variable analog wave patterns which can be transmitted over telephone lines and at the digital data from the transmitted signal (demodulation). Figure 4.8 shows a typical arrangement. Telephone lines can also be used to transmit the analog signals between modems. The usage can be an external modem or a plug-in modem card.



**Fig. 4.8 Modem Connection**

#### 4.4.6 COMPUTER TO COMPUTER COMMUNICATIONS

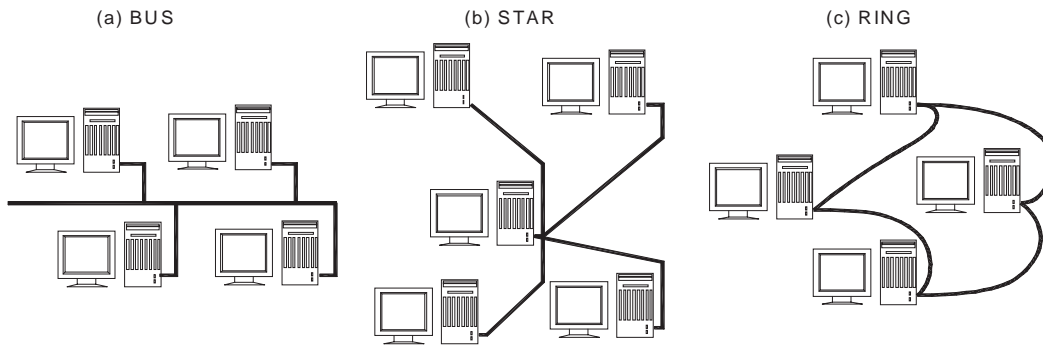
A design office can make use of a number of different computer systems and peripherals. The networking of these computers enables the sharing of peripherals, application software and databases. Across the network the users can also communicate or transfer data or files. The networking if restricted to short distances, say a department or a building, is called a Local Area Network (LAN). A LAN is a system made from the following building blocks that can be added or configured as needed:

- Network server
- Network interface card
- Storage disc
- Connecting Cable
- Workstations

LAN's use special systems to manage the shared resources on the network. These systems are called servers. A server is a combination of hardware and software. A hardware can be a personal computer like a Pentium or a more powerful RISC based workstation or



a minicomputer. The central mass storage disc contains the files and programs that are shared by the designers. Typically a LAN server may require at least 20 to 200 GB of storage space. In order to communicate to a computer, an interface card with the components necessary for sending and receiving messages has to be plugged into the computer. This printed circuit board is called the network interface card or network adapter. The computers to be connected in a LAN may include personal computers of different families, workstations and minicomputers. Each device in the network is attached to a transmission cable so that messages can be sent from one device to another. LANs are run on cables varying from low-cost twisted pair telephone wire to single or multi-channel co-axial cable or expensive high performance fibre optics cable.



**Fig. 4.9 LAN Topologies**

There are different topologies used for networking. The important topologies are described briefly below:

**i. Bus topology**

The bus topology is a simple design with a single length of cable known as bus. All devices on the LAN are attached to the bus and share this single communications medium (Fig. 4.9 a).

**ii. Star topology**

In star topology the computers are arranged on the form of a star, with each device connected to the network server with a separate cable. Though the cable length is more the system has a higher reliability (Fig. 4.9 b).

**iii. Ring network**

Figure 4.9 c shows the ring network. Here the networking is carried out such that the messages pass through the intermediate computers between the sending and receiving computer.

**iv. Hybrid schemes**

Many practical LAN schemes combine some of the above topologies for best performance. Network technologies are discussed in detail in a later chapter.

A typical workstation will have the following networking features as options:

- Ethernet networking connector
- Asynchronous and synchronous communication ports
- Transmission control protocol/Internet protocol (TCP/IP) or XNS
- ISO/OSI, SNA, DEC net, Netware.

**v. Wireless LAN (WLAN)**

Wireless LAN extends the reach of existing wired networks through high frequency radio waves to the entire organization. This is also known as Wi-Fi. IEEE 802.11 is the set of standards for Wireless Local Area Networks. Each computer, mobile, portable or fixed is referred to as a station in 802.11. Portable stations can be used only at fixed points. Mobile stations can access the LAN even while moving. When two or more stations come together to communicate with each other, they constitute a basic service set (BSS). A BSS that stands alone (not connected to a base) is called an Independent Basic Service Set (IBSS). It is also referred to as an Ad-Hoc network. In an ad-hoc network stations are connected only peer to peer. Two or more BSS's are interconnected using a Distribution System (DS). Entry into DS is accomplished using an Access Point (AP). Large and complex networks could be created using several BSS's and DS's.

## 4.5 DESIGN WORK STATIONS

Engineering workstations are computer systems with adequate computing power, based on 32 or 64 bit microprocessors. Workstations are typically divided into two broad categories: Low-end and high-end.

Low-end work stations generally consist of personal computers. Appropriate software and special hardware like graphics accelerator cards are added to these for boosting the performance. Personal computers have the additional advantage of being able to run a substantial amount of software such as programs for analysis, database management, etc. The processing capability of personal computers is generally enhanced by the addition of a co-processor in the microprocessor circuit which increases the processing speed by two or three times. Special custom-built graphics boards increase resolution and decrease drawing times. High resolution color monitors and multifunction cards improve the versatility of personal computers.

High-end workstations are designed around one or more powerful RISC processors. Examples of such processors are PA-RISC, MIPS, and SPARC etc. Hardware in these systems generally consists of high resolution graphics display of 1024 X 1024 pixels, or more, a processor capable of 2 to 4 MIPS or more and 512 MB to 8GB core memory and mass storage in the range of 36-146 GB (Giga Byte), with optional magnetic tape back up. These will also have the ability to operate in a computer net work with other workstations or to work as host computers, to PC nodes which may be intelligent or dumb.

Computers used for high end workstations are optimized for engineering analysis and graphics work. Many of them use custom-built processors often incorporating hardware features to boost the speed of processing. However the systems using standard processors have the advantage of several software packages with practically little customization.

**Workstations consist of three basic components:**

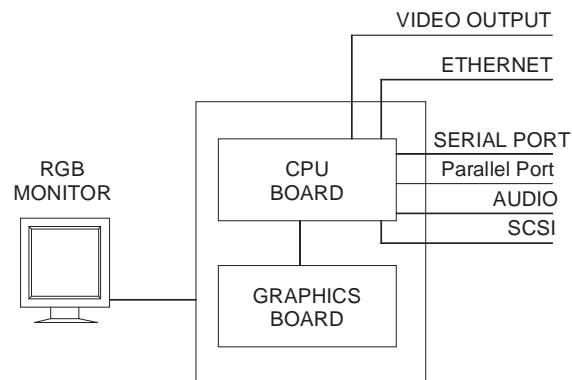
- A primary processor
- Associated memory
- Graphics display system and software

Leading workstations like SUN, IBM, Silicon Graphics, Hewlett-Packard etc., use special architecture based on RISC (Reduced Instruction Set Computing) chips and specialized graphic boards. The graphic features like display manipulation are realized in hardware for fast response. Workstations typically place emphasis on graphics display and manipulation. The features of a display system are directly related to the processing power of the display driver. Functions such as color fill; entity generation and transformation of displays are controlled by the display processor and associated hardware.

Networking ability is a standard feature often incorporated in Workstations. Workstation can be used in a variety of ways. First, they can act as dedicated stand alone processors for certain design or analysis tasks. They can also be networked with each workstation dedicated to a different task or for a particular use. Another way of use of workstations is as front end processors for large host computers. An important feature of a workstation is that they operate in a windows environment using graphic user interfaces like X-Windows or OSF/MOTIF which enables effective implementation of CAE and concurrent engineering approaches.

#### 4.6 ARCHITECTURE OF A TYPICAL GRAPHICS WORKSTATION

Figure 4.10 shows a system level block diagram of a typical high end CAD workstation. A color (RGB) monitors with 19" screen size and resolution of 1280 x1024 pixels is the standard. Some workstations will have monitors with resolution of 1920 x 1200 pixels. Workstations enable the display of the drawings in several colors.



**Fig. 4.10 System Level Block Diagram of a Graphics Workstation**

Selectable palette of 256 colors out of 17.6 million colors is normally available. The hardware include a CPU board with a RISC (Reduced Instruction Set Computing) microprocessor with Cache Memory and 512 MB RAM. Many CAD/CAM applications require at least 24 GB or more of disc capacity. Disc capacity can go up to 140 GBytes in a sophisticated graphics workstation. The communication facilities include two or more serial ports, one or more parallel ports, and TCP/IP Ethernet controller or other facilities for networking. A graphic workstation has also to fit into other networking environments like NFS (Networking File System), IBM Emulation, Hypernet etc.

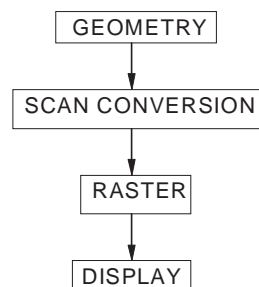
The distinguishing feature of a graphics workstation is the graphics board which does the display generation and manipulation. The graphics subsystem is discussed in detail in the following sections.

#### 4.6.1 GRAPHICS SYSTEM

Graphics system consists of four subsystems:

- a. Geometry engine subsystem
- b. Scan conversion subsystem
- c. Raster subsystem
- d. Display subsystem

These subsystems are shown in Figure 4.11 schematically.



*Fig. 4.11 Subsystems of a Graphics Engine*

#### 4.6.2 GEOMETRY ENGINE

The geometry engine accepts 3-D world co-ordinate data and converts them into X, Y screen co-ordinates. Depth information is manipulated using Z-buffer. Colors are also processed. The geometry pipeline facilitates among other functions lighting, clipping, and 3D to 2D projection, viewing transformations, rotation, scaling and translation.

#### 4.6.3 SCAN CONVERSION

The scan conversion subsystem carries out polygon decomposition, edge slope calculations, span slope calculations and span interpolation. The output of the scan conversion is the pixel information to the raster subsystem.

#### 4.6.4 RASTER SUBSYSTEM

The raster subsystem will have usually 24 bit planes. This will provide eight bit planes for each primary color (RGB) so that (28) shades of a single color can thus obtain.

Since the different colors are obtained by the three primary colors a total of (28)<sup>3</sup> colors are available on the screen.

In a typical raster engine five 256K X 4D RAM provide 4 bits of Z-depth. The raster information is stored in the frame buffer. Twenty 64 K X 4 video RAM provide 4 bits for each pixel of 1280 X 1024 resolution. Entry level systems will have 12 bit planes and high end systems will have 32 bit planes for the frame buffer. These provide the color and depth for the images.

#### 4.6.5 DISPLAY SUBSYSTEM

The display subsystem has multi-mode graphics processors which manage the display, send the Red, Green, Blue color (RGB) data to the respective digital to analog converters as well as provide a video output.

#### 4.6.6 CAPABILITIES FOR MODELING IN A TYPICAL GRAPHICS WORKSTATION ENVIRONMENT

The following modeling capabilities are desired in a workstation:

- a. 2D and 3D modeling and drafting facilities
- b. Display of text
- c. Animation
- d. Color selection (usually a palette of 256 colors)
- e. 3D viewing
- f. Z-buffering
- g. Gouraud shading
- h. Depth cueing
- i. Lighting models
- j. Anti-aliasing
- k. Texture mapping

The RISC based workstations function with UNIX operating system in a Windows environment. A graphics workstation will also provide a graphics library like OPEN GL which provides easy to use and flexible high level graphics subroutines with broad functionalities in a high level language like C or an object orient language like C++ or graphic modules like ACIS and Parasolid. These can be used for creation of graphic models including real time interactive solid models. The user can create a customized graphic software with the aid of such a graphics library.

#### 4.6.7 SPECIFICATIONS OF TYPICAL GRAPHICAL WORKSTATION

Brief specifications of a few typical workstations are given below:

##### *Technical Specifications of a HP Workstation*

###### *System Processing Unit*

Central processor	:	PA-8800 or PA 8900 dual core
Clock frequency	:	900 MHz
Number of processors	:	1 to 4

The above data are given for general information. As technology advances, the specifications will be continuously ramped up. The readers are advised to refer to the catalogues of manufacturers to obtain current information on the hardware, performance specifications etc.

#### 4.7 INTERACTIVE DISPLAY DEVICES

##### 4.7.1 INTERACTIVE GRAPHIC TERMINALS

Interactive graphics is an important component of CAD providing a window through which the communication with the computer can be realized. Such systems which enable communication between the human operators and the computer are called “user-friendly” or simply friendly computers. In an interactive graphics session, the user constructs a geometric model by specifying points, lines, arcs and circles on the screen. When each command is issued, the software will request additional data often supplying some of the information needed. There is always a “HELP” feature which the designer can consult if he is in doubt. Technically the model is the mathematical representation of the diagram in the computer data base. The operator uses the display screen almost in the same manner as a drawing board to create various projections or views of the object. But unlike manual drafting, CAD incorporates several features to speed up drafting and increase drafting productivity. The display devices be can classified into two groups:

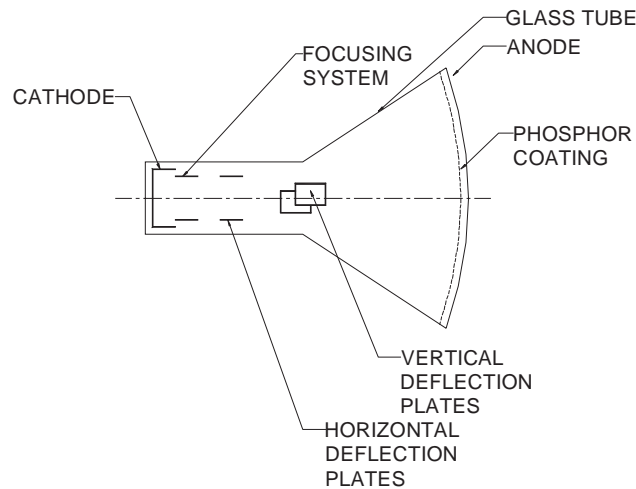
- i. Display devices based on CRT principle
- ii. Flat screens

Most interactive CAD systems use CRT based graphic monitors. CRT is a glass enclosed tube in which a finely focused electron beam is deflected to a phosphor coated screen. The screen then glows to produce a visible trace when excited by impinging electrons. The principle of operation of a monitor is given below.

##### 4.7.2 DISPLAY DEVICES BASED ON CRT

The position of the visible trace on the CRT screen is controlled by a focusing system and a set of horizontal and vertical deflection plates as shown in Fig. 4.12.

In a color CRT, there are three electron guns, one each for red, green and blue. The phosphor dots for red, green and blue are arranged in a triangular pattern. The individual beams intersect at a shadow mask which directs a red beam to a red phosphor dot and so on.

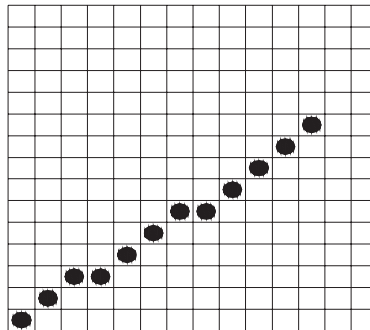


**Fig. 4.12 Principle of a CRT**

### 4.7.3 RASTER SCAN TECHNIQUE

The screen of a monitor can be considered to consist of a large number of minute subdivisions called picture elements (pixels, in short). For example, in a typical SVGA monitor, the screen is divided horizontally into 1024 units and vertically into 768 units. The resolution of this monitor is then 1024 x 768.

A raster CRT graphics device can be considered a matrix of discrete cells each of which can be made bright. Thus it is basically a point plotting device. If a line is to be drawn, it can be approximated by a series of dots close to the path of the line. Figure 4.13 illustrates this concept.



**Fig. 4.13 Line Drawing**

Let us assume that a line AB is to be drawn. On a raster scan monitor, the adjacent pixels closer to the path of the line are addressed and the resulting "line" appears to have a staircase like look or is said to be jagged. However, the resolution is more, then the line appears smooth. Vertical or horizontal lines appear smooth, irrespective of the resolution.

A frame buffer is a common method of implementing a raster CRT graphics device. It can be considered to be a large contiguous piece of computer memory. In the simplest can, there can be one memory bit for each pixel in the raster. This amount of memory is called a bit plane. A 320 X 200 raster requires 64 K memory bits in a single plane. The picture is built in the frame buffer one bit at a time. The memory bits can be either in 0 or 1 state. If a particular pixel is to be addressed, the corresponding bit in the frame buffer is changed from 0 to 1. Since the raster CRT is an analog device, it requires an electrical voltage and the digital data of the frame buffer has to be converted to an analog voltage through a digital to analog converter (DAC). This is schematically shown in Fig. 4.14.

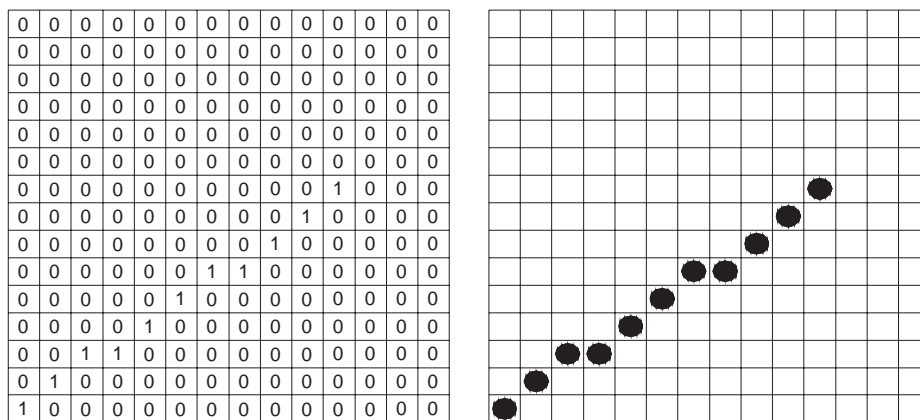


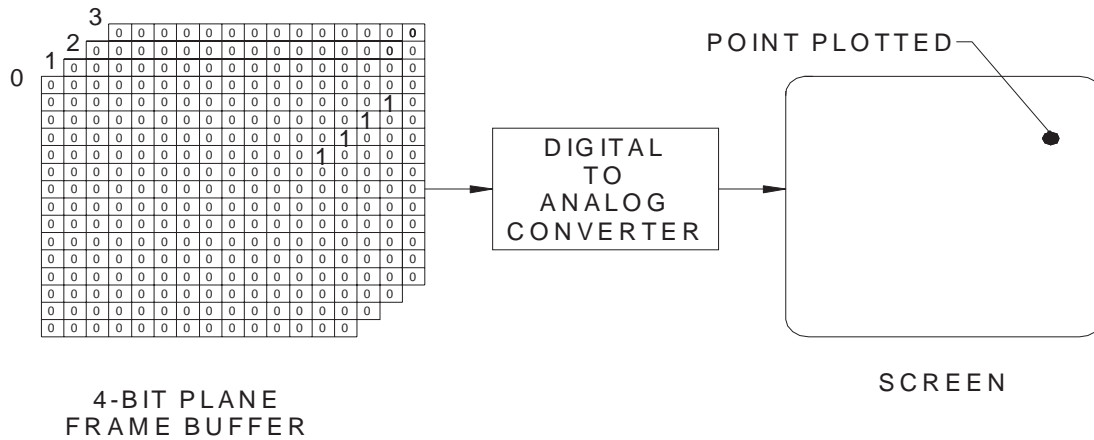
Fig. 4.14 Frame Buffer

A single bit plane yields a black and white display. Color or different grey levels can be achieved by using additional bit planes. Fig. 4.15 shows 4 bit plane frame buffer. The intensity of each pixel in the CRT is decided by the combination of the pixel values. (1111 in the picture shown). Since there are four bit planes, there can be  $2^4$  (=16) combinations. The resulting binary number is interpreted as an intensity level between 0 and  $2^4 - 1$  (=15). This is converted into a voltage between 0 (dark) and 15 (full intensity), by the digital to analog converter.

Thus this arrangement can represent 16 grey levels or color shades.

The color graphics monitors are usually referred to as RGB monitors since the different colors are obtained by mixing three primary colors, Red (R), Green (G), and Blue (B). A simple color frame buffer can be implemented with three bit planes, one for each primary color.





**Fig. 4.15 4-bit Plane Frame Buffer**

Each bit plane drives an individual color given for each of the three primary colors. This arrangement can lead to eight colors as given in the Table 4.3.

**Table 4.3 Color Table**

Black	0	0	0
Red	1	0	0
Green	0	1	0
Blue	0	0	1
Yellow	1	1	0
Cyan	0	1	1
Magenta	1	0	1
White	1	1	1

Additional bit planes can be used for each of the three color guns. In a 24 bit plane buffer 8 bit planes are used for each color. Each group drives a 8 bit Digital to Analog Converter (DAC) and can generate  $2^8 = 256$  intensities of red, green and blue. This when combined together can result in  $(2^8)^3 = 16,777,216$  or 16.7 million possible colors.

#### 4.7.5 FLAT SCREENS

CRT has the disadvantage that it is extremely bulky. Moreover, CRT consumes considerable power with increased heat dissipation requirements. Portability is reduced because of the size and the material of CRT. These disadvantages have prompted the manufacturers try different types of flat screens as output devices for computers. Flat screens are necessary for laptop, notebook and palm top computers. Flat screens operate on the principle of liquid crystal display.

## 4.8 INPUT DEVICES

For interactive graphic tasks more often several input devices are used. These allow entering data in an easily interpretable graphic form. The task is usually accomplished by controlling the position of a set of cursor cross hairs on the screen. Some devices like light pen are touched on the screen for more direct interaction. Some of the input devices which are employed for graphic applications are described in the following sections.

### 4.8.1 KEYBOARD

The keyboard interacts with the computer on a hardware and software level. The keyboard contains a keyboard controller (like 8042 or 8048) to check if any key is pressed or released. If any key remains closed for more than half a second the controller sends a repeat action at specific intervals. It has limited diagnostic and error checking capabilities. A buffer is normally available to store a certain number of key actions if the computer is busy.

### 4.8.2 TOUCH SCREENS

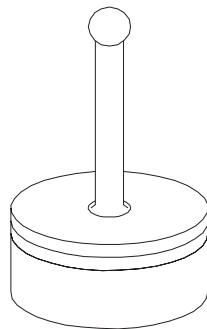
Touch screens are direct devices. They are used by simply touching CRT display with one's finger or a pointing device. Two types of touch screens (mechanical and optical) are used in CAD applications.

Mechanical type is a transparent screen overlay which detects the location of the touch. Optical touch screen systems use rows of light emitters and receptors mounted just in front of the screen with the touched location determined by broken beams.

Mechanical systems have a resolution of 0.25 mm in position detection. These devices are more popular as cursor control systems. Optical systems are of low resolution and are mainly used for menu selection.

### 4.8.3 JOYSTICKS

Joystick is a potentiometric device that contains sets of variable resistors which feed signals that indicates the device position to the computer. These devices rely on the operator's sense of touch and hand-eye co-ordination to control the position of the cursor on the screen. (Fig. 4.16)



**Fig. 4.16 Joy Stick**

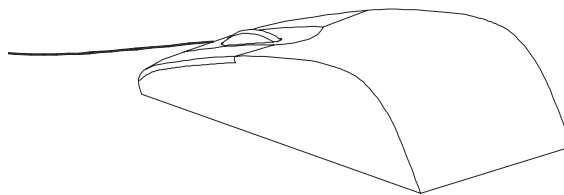
Joystick devices are normally set so that side-to-side movement produces change in X Co-ordinates and front to back movements produce change in Y Co-ordinates. Thus they are best suited for pointing in tasks such as menu selection or creating simple schematics. Many users prefer joysticks because they allow rapid cursor movement for relatively small device movements, enabling graphic operations to be performed quickly. Three dimensional capability is possible by moving the handle up and down or by twisting it to provide data entry in the Z-axis.

#### 4.8.4 TRACK BALLS

Track ball has a ball and socket construction but the ball must be rolled with fingers or the palm of the hand. The cursor moves in the direction of the roll at a rate corresponding to rotational speed. The user must rely heavily on the tactile sense when using a trackball since there is no correspondence between the position of the cursor and the ball. The ball momentum provides a tactile feed back. Trackballs are effective for tracking, following or pointing at moving elements. Track discs also perform a similar function.

#### 4.8.5 MOUSE

Mouse is today one of the widely used input devices in graphics applications. Mouse is a small hand held puck like instrument which is attached to the computer (Fig. 4.17). Mouse can be moved around by the operator on any flat surface to provide graphic input. Its ability to rapidly position the cursor on the screen is its most important advantage. Mouse is available as a mechanical or optical graphic input device. In the case of a mechanical mouse, the rolling ball at the bottoms of the mouse causes two encoders to rotate. The movement of the mouse is thus converted into pulses which move the cursor in the X and Y direction in proportion to the movement of the mouse. Mouse can be operated in a limited space. Since the mouse can be used without looking at it, the user can concentrate on the screen and hence design productivity can be considerably increased.

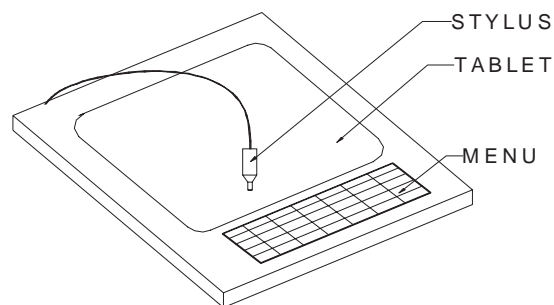


**Fig. 4.17 Mouse**

An optical mouse works on the basis of signal generated by the reflecting light from a special metallic plate or which the mouse is moved. The source of light is an LED located underneath the mouse. There are no moving parts in an optical mouse and that is an advantage over the mechanical mouse. Slippage at the contacting surfaces is a disadvantage of mouse.

### 4.8.7 DIGITIZER

Digitizer boards or tablets are electro-mechanical vector graphic input devices that resemble a drafting board. These are used together with a movable stylus or reticule called a cursor or a puck. They are used to enter drawings into computer graphics systems by taping the drawing to the surface of the digitizing board and placing the cursor over points whose co-ordinates are to be entered. Figure 4.18 shows a digitizer.



**Fig. 4.18 Digitizer**

A digitizer consists of three basic elements: a locator in the form of a pen or stylus or puck or cursor, a tablet and a software package. A digitizer can be used to copy existing drawings and send the geometric data directly to the computer. But more frequently digitizers are used to create a drawing using an interactive drafting package to enter a sketch or a drawing which can then be redrawn or edited as the display appears on the CRT screen. The operation of a digitizer is similar to that of a mouse. The user moves the stylus or puck across the flat surface of the tablet. The surface of the tablet is magnetized and is embedded with wires in X and Y directions. The tablet surface can be configured to represent the screen. The physical motion of the stylus is converted by the wires into digital location signals received by the locator. The coded electrical or acoustic signal is then routed to the computer and displayed on the graphic terminal.

Digitizers are available in various sizes up to 1250 X 1600 mm. Of the two commonly used locators, the puck cursor is generally more accurate. Its cursor has a sighting device, usually a lens with cross hairs and integral push button pads for entering commands, defining points and making other digitizing operations. In many of these systems, the work surfaces on which drawing data are entered also contain the function menu.

Data can be picked up by the cursor in two general modes. In the point mode, the user locates specific points with the cursor and presses the appropriate function buttons to enter the data. A typical operation will be to enter the end points of a straight line. In the stream mode, a continuous flow of data points is sent to the processor with the data rate determining digitizer's resolution. This method is used for entering curves and shapes of irregular nature.

Some type of digitizers can pick 3-dimensional information from a model, moving the tip of a wand along the model. These systems generate signals that are analyzed to produce co-ordinates. This type of digitizer is very useful for reverse engineering. In the case of sonic digitizers a spark gap in the stylus tip creates a sound pulse that is detected by two strip microphones one for X and one for Y axis. The location of the source of sound is indicated by the time it takes for the sound to reach the microphones. The sonic digitizer does not require a tablet.

The major sub-groups of standard digitizers are free cursor digitizers, constrained cursor digitizers and motorized cursor digitizers.

#### **4.8.7 THUMB WHEEL**

Thumb wheels are potentiometric devices. Two of them are provided for X and Y movements of cursor. These also have the advantage that one can look at the screen and move the cursor.

#### **4.8.8 AUTOMATED ENTRY**

One of the major needs of design offices switching over to CAD is the necessity to convert existing paper drawings to computer files. Many automated devices are now available for entering drawings into CAD database. These units can scan a drawing and convert them into a form useful for CAD with little manual intervention. A typical automated drawing entry device contains a scanner and a workstation for viewing and editing the drawing. Software is required for rasterizing and vectorizing the scanned drawings.

Most systems begin the data entry process by scanning a document to create a raster image. A scanning rate of 13 dots/mm is adequate for most engineering applications. The pixel data may be stored or manipulated by converting it into vectors with the aid of sophisticated software. At the work station vectors are organized into graphic primitives such as line, arcs, circles, etc. symbols and text may also be recognized by the system and are converted into a single piece of data. Many systems can even recognize handwritten lettering.

Recently artificial intelligence techniques similar to those employed in robot vision technology have been used for automatic entry of drawing into the computer. Texts are usually entered in separate layers to enable easy revision.

### **4.9 OUTPUT DEVICES**

A CAD system is not complete unless it can make hard copies of designs or analysis created on the computer. Determining the best output device for a typical CIM application is a three-step process: specifying how hard copies will be used, identifying quality and cost criteria and selecting equipment most suitable for the application.

Hard copies are used for a variety of purposes, including shop use, file storage, reports and presentations. Design iterations can be reduced by making hard copies at crucial stages and distributing them to key personnel for review. Documents and drawings are required

for archival purposes, to be used in proposals, reports, as well as illustrations. Quality of the hard copy depends on the resolution of the hard copy unit. Speed and frequency of operation of hard copy equipment are also of importance.

#### 4.9.1 PLOTTERS

Plotters are classified based several factors. Depending on the maximum size of the drawing plotters are designated as A0, A1, A2, A3 and A4. There are plotters capable of creating drawings larger than A0 size. Generally plotters plot drawings on cut sheets. Some special plotters are capable of creating drawings on rolls also. Drawings are created through a series of short vectors which requires movement to the pen in X and Y direction. Plotters can be classified on the basis of their construction. A flat bed plotter has the pen moving on a flat surface on which the drawing paper is fixed. The linear movements in the X and Y direction generate the required drawing. In the case of a drum plotter, the paper is wound around on a cylindrical drum. The pen holder is attached to a moving slide.

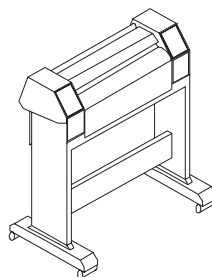
The co-ordinated motion generated by the rotation of the drum and linear movement draws the pictures on the paper. In the third type, i.e. the pinch roller plotter, the paper is tightly held between two sets of rollers. One roller in each pair has a rough surface and the linear motion to the paper in one direction is imparted by the rotation of the roller. The movement in the other direction is through a linear motion imparted to the pen holder.

Plotters can also classify as pen plotters and electrostatic plotters. Pen plotters use 1, 4, 8 or more different color pens. The drawings thus can be made in several colors. Pencil plotters are also available. Electrostatic plotters are faster but there is no color variety. They are also cheaper.

Plotters have high resolution which is specified by dots/mm. The pen speed and pen pressure are programmable. Various line thicknesses can be obtained by using pens of different tip sizes. Generally fibre tip pens are used.

Pen plotters are slow and shading is difficult. Pen plotters also require more maintenance and the ink or fibre tip or ball point pens should be changed frequently to keep line quality high.

Inkjet plotters are the ones that are now commonly used. These are available in color or monochrome versions. These are fast, reliable and more accurate than pen plotters. Figure 4.19 shows a plotter.



**Fig. 4.19 Plotter**

## 4.9.2 PRINTERS

*Several types of printers are available:*

- (i) **Impact printers:** They use small hammers or print heads containing small pins to strike a ribbon to form dot matrix images. Colors are introduced through the use of multiple ribbons or single ribbons with different color bands. Color intensity is fixed and creating shades is almost impossible. Because of the low resolution, copy quality is poor. Impact printers are suitable for high speed, low cost, high volume hard copies.
- (ii) **Inkjet printer:** Inkjet printers produce images by propelling fine droplets of ink on to the medium to be printed. Droplets can be generated in continuous streams or pulses. Some of the droplets get charged and are returned to the reservoir, while uncharged droplets attach to the printing surface to form graphics. The laser jet printers are capable of giving good quality color prints with shading at reasonable cost.
- (iii) **Laser printer:** Laser printer is one of the most widely used output devices. This type combines high speed with high resolution and the quality of output is very fine.

## QUESTIONS

1. Describe the principal features and list the major specifications of a personal computer.
2. Sketch and describe the layout of the mother board of a Pentium PC.
3. How does a mainframe computer differ from a PC?
4. What are the output interfaces available on a PC? How do they differ from each other?
5. Describe the advantages of a local area network in a design environment?
6. What are the salient features of a UNIX based design workstation?
7. What are the principal subsystems of a graphics engine?
8. List the major specifications of a design workstation.
9. Describe the principle of working of a CRT.
10. How is a line displayed on a graphics monitor?
11. What is the function of a frame buffer?
12. What is the advantage of a mouse as an input device?
13. Compare the relative merits and demerits of different input devices.
14. What are the important output devices used in CAD?

# OPERATING SYSTEMS AND ENVIRONMENTS

*Operating systems represent very significant class of software essential for the operation of a computer. The Application software must be compatible with the operating system. Different operating systems are used in computers. This chapter gives a brief overview of popular operating systems like UNIX, Windows and Linux.*

## 5.1 INTRODUCTION

Software that is of interest to CAD/CAM/CIM Engineers falls under different categories. They are:

- i. Operating Systems
- ii. Application Software for
  - a. Geometric modeling
  - b. Design and analysis of components and systems
  - c. Finite elements analysis
  - d. Mechanism analysis
  - e. Other design applications
  - f. CNC programming
  - g. Process planning
  - h. Tool Design
  - i. Inspection
  - j. ERP

General aspects of operating system software are discussed in this chapter. A section on files and file handling is included to familiarize the reader in one of the important stages in program development. Since separate chapters on application software for design and analysis are included, they are not discussed in this chapter. Details of geometric modeling software are dealt with at length in several chapters.



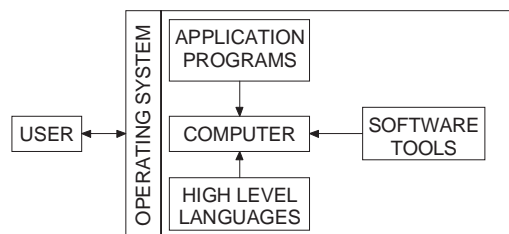
## 5.2 OPERATING SYSTEM (OS)

An Operating System is basically a set of programs that provide control of the CPU (Central Processor Unit) and its resources. Any general-purpose computer, such as a PC or a Mac requires an Operating System (OS) to organize the various hardware and software components that make up the system. An operating system (OS) is a set of interrelated collection of supervisory software that controls the overall operation of the computer to supervise its own operations by calling in the application programs and managing the data needed to produce the desired output by the users. As shown in Fig. 5.1 the operating system acts as an interface between the user and the computer hardware. The computer system running under OS control range from small personal computers to mainframe and super computers. The programs in an OS control the flow of information among the many units of the computer, namely the processor, memory, disc drive, keyboard, monitor, printer, plotter etc.

### ***The important functions of an operating system are:***

- i. Transferring data between computer and various peripheral devices for input and output. This function primarily controls devices through special programs called device drivers.
- ii. Managing computer files and programs through processor management which controls access to CPU so that each program has its fare share of processor time.
- iii. Loading computer programs into memory and controlling program execution. Memory management controls different memories associated with the computer and allots the quantum of memory required for each application.
- iv. Security.
- v. Human Interface. This determines how the user communicates with the computer.

Micro computers and personal computers use three major categories of operating systems. A ROM monitor is the simplest type of operating system. It is designed for a particular configuration of hardware and provides a program with direct access to the hardware. Such systems are commonly used in dedicated hardware. An example is a CNC system. The traditional operating system is an improvement on the ROM monitor. ROM monitor is retained as the basic input/output system. (BIOS) Additional features such as file system and logical access to peripherals are added. Programs are stored in peripheral storage devices like disc drives.



**Fig. 5.1 Operating Systems**

An operating environment is built on a traditional operating system. This provides additional services to simplify program operation. Graphical user interface like Windows 95, Windows 98, Windows <sup>XP</sup>, Windows 2000 Professional, Windows NT etc for personal computers and X-windows, OSF / MOTIF, Presentation Manager in the case of RISC workstations etc. are examples of operating environments. Table 5.1 compares the characteristics of three major types of operating systems.

**Table 5.1 Comparison of Characteristics of Three Major Types of Operating Systems**

<i>Characteristics</i>	<i>ROM Monitor</i>	<i>Traditional Operating System (OS)</i>	<i>Operating Environments</i>
Complexity	Low	Medium	High
Built on	Hardware	BIOS	OS
Delivered on	ROM	Disc	Disc
Programs on	ROM	Disc	Disc
Peripheral support	Physical	Logical	Logical
Disc access	Sector	File system	File system
Example	PC ROM	MS-DOS UNIX (Solaris, AIX, HP-UX)	Windows 95, Windows 98, Windows NT Windows 2000 Windows <sup>XP</sup> Windows Prof. X-Windows

Thorough knowledge of the operating system is essential to make the best use of the computer. The OS commands can be used to set the date and time, create a directory, check the status of the disc, change directory, create folders, clear display screen, copy a file, delete a file, rename a file, format a disc etc. The OS will have a built-in editor.

There are numerous programs in a typical operating system. These programs can be broadly classified into two groups:

- i. Control programs
- ii. Processing programs

### 5.2.1 CONTROL PROGRAMS

One of the major functions of an operating system is to control input and output operations. They also control the data flow between the memory and the secondary storage devices. The OS monitors keyboards, mouse, display screens and printers. The operating system will have a supervisory program called kernel. This coordinates all other programs and resides in the RAM of the computer.

The operating system usually is stored in the hard disc. When the computer is switched ON a “bootstrap” program permanently located in the ROM of the computer is used to automatically load the kernel into the RAM. In the case of Windows, once the OS is loaded into the computer, the desk top is displayed on the screen. Frequently used software or programs can be accessed directly from the desk top.

Another function of OS is to provide automatic job-to-job linkage through a job control program, system scheduling, handling of system interrupts and monitoring system status and displaying appropriate messages to users are some of the other functions of OS.

### 5.2.2. PROCESSING PROGRAMS

OS can call up several translating programs, utility programs and library programs. Translating programs are used to translate programs in source code to machine language codes. Examples of utility programs are those used for sorting records in a particular sequence or processing, merging several files together. Library programs are a set of standard programs which can be accessed from the direct access storage device to be integrated in an application program.

## 5.3 COMPARISON OF COMMANDS IN POPULAR OPERATING SYSTEMS

Operating systems are supplied by computer manufacturers or software vendors. Many operating systems have been developed in the past. Some of them are listed below:

- MS-DOS [Microsoft Disc Operating System]
- PC-DOS
- OS-2
- MS-Windows
- UNIX
- LINUX
- Apple MAC OS

The Table 5.2 shows a comparison of the common commands used in some operating systems.

**Table 5.2 Commands in Different Operating Systems**

<b>Functions</b>	<b>MS-DOS Commands</b>
CREATE A SUBDIRECTORY	MD\Dir_name
MOVE TO A SUBDIRECTORY	CD\Dir_name
SEE THE CURRENT DIRECTORY	CD
LIST SUBDIRECTORIES	DIR*
LIST FILES IN A SUBDIRECTORY	DIR \Dir_name
DELETE FILES IN A SUBDIRECTORY	DEL \Dir_name\*.*

*Contd....*

<i>Functions</i>	<i>MS-DOS Commands</i>
DELETE A SUBDIRECTORY	RD \Dir_name
LIST FILES OF SAME EXTENSION	Dir *.Ext
LIST FILES, FILENAME STARTING WITH X	DIR X*.*
COPY FILE FROM HARDDISC TO FLOPPY	COPY C:Filename.Ext A:
CREATE A FILE	EDLIN Filename.Ext
EDIT A FILE	EDLIN Filename.Ext
DISPLAY FILE CONTENTS	TYPE Filename.Ext
PRINT A FILE	PRINT Filename.Ext
SORT FILES IN A SUBDIRECTORY	DIR \Dir_name   SORT
RENAME A FILE	REN Oldname.Ext Newname.Ext
APPEND ONE FILE TO OTHER	COPY File1.Ext+File2.Ext Newname.Ext
SEARCH A STRING IN A FILE	SFIND "String" Filename.Ext
CHANGE ATTRIBUTE OF A FILE (Read only)	ATTRIB +R Filename.Ext
(Read/Write)	ATTRIB -R Filename.Ext
CREATE A SUBDIRECTORY	mkdir Dir_name
MOVE TO A SUBDIRECTORY	cd \Dir_name
SEE THE CURRENT DIRECTORY	pwd
LIST FILES IN A SUBDIRECTORY	ls Dir_name
DELETE FILES IN A SUBDIRECTORY	rm Dir_name/?*.*
DELETE A SUBDIRECTORY	rm Dir_name
LIST FILES OF SAME EXTENSION	ls *.Ext
LIST FILES, FILENAME STARTING WITH X	ls X*.*
COPY FILES FROM ONE SUBDIRECTORY TO ANOTHER	cp source_Dir/Filename.Ext Dest_Dir
MOVE FILE FROM ONE SUBDIRECTORY TO ANOTHER	mv Source_Dir/Filename.Ext Dest_Dir
COPY FILES FROM CATRIDGE TAPE TO HARD DISC	tar -xvb device-name
COPY FILES FROM HARDDISC TO CATRIDGE TAPE	tar -cvb device-name
CREATE A FILE	vi Filename.Ext
EDIT A FILE	vi Filename.Ext
DISPLAY FILE CONTENTS	cat Filename.Ext
PRINT A FILE	lp Filename.Ext
RENAME A FILE	mv Source.Ext Newname.Ext
APPEND ONE FILE TO OTHER	cp Firstfile.Ext+Secondfile.Ext Newfile
CREATE LINK TO A FILE IN A SUBDIRECTORY	ln Link-name File_path
SEARCH A STRING IN A FILE	grep String Filename.Ext

Contd....

CREATE A NEW PROCESS	cp /sys5/bin/sh
DISPLAY PROCESSES STATUS	ps
KILL A PROCESS	kill Process_number
HARD DISC USAGE	du
SPELLING CHECK	spell Filename.Ext
SIZE OF A FILE	size Filename.Ext

## 5.4 UNIX - OPERATING SYSTEM

The UNIX operating system was pioneered by Ken Thompson and Dennis Ritchie at Bell Laboratories in the late 1960's. UNIX is a trademark of AT & T Bell Laboratories.

UNIX is time-sharing, multi-tasking and open operating system. It is a modular integrated set of software that resides on and co-ordinates computer system resources. The UNIX system serves as the interactive interface between the user and the computer system.

UNIX is turning out to be a world standard universal operating system. Today, UNIX runs on all types of computers from Cray and Fujitsu Supercomputers to IBM PCs, Apple's Macintoshes and even on lap tops.

## 5.5 ARCHITECTURE OF UNIX SYSTEM

UNIX is having four main architectural layers:

- i. Hardware (Firmware)
- ii. Kernel (Scheduler)
- iii. Shell, Utilities, Software tools
- iv. Application programs

***UNIX operating system consists of:***

- A central operating system program (KERNEL).
- An assortment of utilities like init, gett, login, stty, mkfs, mknod, clri, sync, mount, unmount, nice, ps, make etc.
- And a file structure; ordinary file, directory files, fifo files and special files. This file structure architecture provides a convenient and useful method for partitioning utilities.

### 5.5.1 FUNCTIONS OF UNIX KERNEL

The Unix Kernel is the core of the UNIX system. Every process interacts with the kernel in some way, either directly or by making a system call, or indirectly by being allowed to run. It is a single program whose jobs are to allocate the CPU among computing processes, services request from those processes and accesses files. Kernel is a single program written in a general purpose programming language like C. It includes

- Interrupt and error handling
- System accounting
- Memory management
- Process scheduling and management
- Input/Output services
- File management and security
- Date and time services

### 5.5.2 FUNCTIONS OF THE SHELL

In AT & T's version the Bourne shell prompt is '\$' and Berkeley's BSD shell prompt is '%'. The shell is an interpreter program which acts for:

- Program execution
- Interactive programming language
- Pipe-line hookup
- Input/Output redirection
- Filename substitution

### 5.5.3 REASONS FOR THE POPULARITY OF UNIX

The popularity of UNIX can be attributed to many of its very distinctive features. Some of them are listed below.

- A general purpose system for performing a wide variety of jobs or applications.
- An interactive environment that allows you to communicate directly with the computer and receive immediate responses to your requests and messages.
- A multi-user environment that allows you to share the computer's resources with other users without sacrificing productivity.
- The system's main asset is its portability, the relative ease with which it can be implemented on different hardware, software systems and architectures.
- UNIX has achieved the status of a de-facto standard in the computer industries.
- Net-working in enterprise wide client-server computing.
- UNIX has found a home on workstations. It matches up naturally with Reduced Instruction Set Computing (RISC) workstations.
- Distributed processing capability, satellite, and fully transparent distributed system.
- POSIX - Portable Operating System Interface,

- Shell programming
- Sophisticated security for user, group, others and file, record locking with encode decode facility.
- UNIX supports almost all programming languages.
- UNIX offers many “vertical” applications such as financial modeling, robotics and medical billing.

Because of the availability and wide acceptability of UNIX, hundreds of software tools and utilities have been developed with the help of which a programmer can save his time and can utilize it for better software development for the effective use of computer.

***UNIX serves all levels of users:***

Office automation	-	Text processing, text formatting.
Terminal operator	-	Online transaction processing (OLTP).
Programmer	-	Plenty of utilities are available to reduce miscellaneous programming.
Engineers	-	Work stations (CAD, CAM, CASE, and Robotics).
Managers	-	Shell programming for query purpose, mail processing for decision making.
Multi-unit industry	-	By using extensive networking communication facilities.

#### 5.5.4 BASIC UNIX SYSTEM COMMANDS

**at:** Request that a command be run in background mode at a time you specify on the command line. If you do not specify a time, at (1) displays the job numbers of all jobs you have running in at (1), batch (1), or background mode.

A sample format is:

```
at 8:45am Jun 09 <CR>
command1<CR>
command2<CR>
<^d>
```

If you use the at command without the date, the command executes within 24 hours at the time specified.

**banner:** Display a message (in words one to ten characters long) in large letter on the standard output.

**batch:** Submit command(s) to be processed when the system load is at an acceptable level. A sample format of this command is:

```
batch<CR>
command1<CR>
command2<CR>
<^d>
```

You can use a shell script for a command in `batch(1)`. This may be useful and timesaving if you have a set of commands you frequently submit using this command.

- cat:** Display the contents of a specified file at your terminal. To halt the output on an ASCII terminal temporarily, use `<^s>`; type `<^q>` to restart the output. To interrupt the output and return to the shell on an ASCII terminal, press the BREAK or DELETE key.
- cd:** Change directory from the current one to your home directory. If you include a directory name, changes from the current directory to the directory specified. By using a path name in place of the directory name, you can jump several levels with one command.
- cp:** Copy a specified file into a new file, leaving the original file intact.
- cut:** Cut out specified fields from each line of a file. This command can be used to cut columns from a table, for example.
- date:** Display the current date and time.
- diff:** Compare two files. The `diff(1)` command reports which lines are different and what changes should be made to the second file to make it the same as the first file.
- echo:** Display input on the standard output (the terminal), including the carriage return, and returns a prompt.
- ed:** Edit a specified file using the line editor. If there is no file by the name specified, the `ed(1)` command creates one.
- grep:** Search a specified file(s) for a specified pattern and prints those lines that contain the pattern. If you name more than one file, `grep(1)` prints the file that contains the pattern.
- kill m:** Terminate a background process specified by its process identification number (PID). You can obtain a PID by running the `ps(1)` command.
- lex:** Generate programs to be used in simple lexical analysis of text, perhaps as a first step in creating a compiler.
- lp:** Print the contents of a specified file on a line printer, giving you a paper copy of the file.
- lpstat:** Display the status of any requests made on the line printer. Options are available for requesting more detailed information.
- ls:** List the names of all files and directories except those whose names begin with a dot (.). Options are available for listing more detailed information about the files in the directory.
- mail:** Display any electronic mail you may have received at your terminal, one message at a time. Each message ends with a prompt. `mail(1)` waits for you to request an option such as saving, forwarding, or deleting a message. To obtain a list of the available options, type `?`.



When followed by a login name, mail(1) sends a message to the owner of that name. You can type as many lines of text as you want. Then type <^d> to end the message and send it to the recipient. Press the BREAK key to interrupt the mail session.

- mailx:** mailx(1) is a more sophisticated, expanded version of electronic mail.
- make:** Maintain and support large programs or documents on the basis of smaller ones.
- mkdir:** Makes a new directory. The new directory becomes a subdirectory of the directory in which you issue the mkdir command. To create subdirectories of files in the new directory, you must first move into the new directory with the cd command.
- mv:** Move a file to a new location in the file system. You can move a file to a new file name in the same directory or to a different directory. If you move a file to a different directory, you can use the same file name or choose a new one.
- nohup:** Place execution of a command in the background, so it will continue executing after you log off to the system. Error messages are placed in a file called nohup.out.
- pg:** Display the contents of a specified file on your terminal, a page at a time. After each page, the system pauses and waits for your instructions before proceeding.
- pr:** Display a partially formatted version of a specified file at your terminal. The pr(1) command shows page breaks, but does not implement any macros supplied for text formatter packages.
- ps:** Display the status and number of every process currently running. The ps(1) command does not show the status of jobs in the at(1) or batch(1) queues, but it includes these jobs when they are executing.
- pwd:** Display the full path name of the current working directory.
- rm:** Remove a file from the file system. You can use metacharacters with the rm(1) command but should use them with caution; a removed file cannot be recovered easily.
- rmdir:** Remove a directory. You cannot be in the directory you want to delete. Also, the command will not delete a directory unless it is empty. Therefore, you must remove any subdirectories and files that remain in a directory before running this command on it.
- sort:** Sort a file in ASCII order and display the results on your terminal. ASCII order is as follows:
  - i. numbers before letters
  - ii. upper case before lower case
  - iii. alphabetical order
- spell:** Collect words from a specified file and check them against a spelling list. Words not on the list or not related to words on the list (with suffixes, prefixes, and so on) are displayed.

- stty:** Report the settings of certain input/output options for your terminal. When issued with the appropriate options and arguments, `stty(1)` also sets these input/output options.
- uname:** Display the name of the UNIX system on which you are currently working.
- uucp:** Send a specified file to another UNIX system.
- uname:** List the names of remote UNIX systems that can communicate with your UNIX system.
- uupick:** Search the public directory for files sent to you by the `uuto(1)` command. If a file is found, `unpick(1)` displays its name and the system it came from, and prompts you (with a `?`) to take action.
- uustat:** Report the status of the `uuto(1)` command you issued to send files to another user.
- uuto:** Send a specified file to another user. Specify the destination in the format `system login`. The system must be on the list of systems generated by the `uname(1)` command.
  - vi:** Edit a specified file using the `vi(1)` screen editor. If there is no file by the name you specify, `vi(1)` creates one.
  - wc:** Count the number of lines, words and characters in a specified file and display the results on your terminal.
  - who:** Display the login names of the users currently logged in on your UNIX system. List the terminal address for each login and the time each user logged in.
  - yacc:** Impose a structure on the input of a program.

## 5.6 GRAPHICAL USER INTERFACES (WINDOWS ENVIRONMENT)

A GUI is one in which the programmer or user interacts with a software through a system of menu consisting of pictures or symbols (icon).

The access to the software is through Dialog boxes or icons.

A mouse is used to pick the icons from the screen. In the Icon menu, pictures will be shown on the screen and the user can move a cursor on the screen by moving the mouse to the particular picture and clicking the mouse button.

A Dialog box pops up on the window when the program needs more information. It always appears when you select a command. A dialog box also has various sections.

- i. Text box
- ii. Option button
- iii. Check box
- iv. List box
- v. Drop down list
- vi. Command buttons

In short, GUI makes use of a software a lot easier. Apple Macintosh is the first computer to introduce the graphical user interface. This was followed by the windows software of Microsoft. Today there are several GUI packages, out of which MS Windows, X Windows, DSF/MOTIF, and presentation Manager are more popular.

## 5.7 MS WINDOWS

Microsoft windows is a graphic user interface, which also makes DOS housekeeping tasks such as copying files, formatting discs etc easier. It supports multitasking. It is called as windows because each program runs inside a separate window on the screen. A window is a box or frame on the screen. Many number of windows can be run on the screen at the same time, each containing its own program. The window which appears on the top is called the foreground window. The other windows are called background windows. The importance to each of these windows can be controlled by the program manager. Any window can be made foreground or background by switching between windows using the input device.

With certain limitations windows allows copying material from one to another. The application programs which use the GUI of windows are called as window application programs, and other DOS programs are called as non-window application programs. All windows application programs will be able to run in a windows environment.

### ***In brief advantages of windows are:***

- i. It has an elegant GUI
- ii. It supports multitasking in DOS and makes use of the CPU time very efficiently
- iii. It is also network transparent

### **5.7.1 STRUCTURE OF WINDOWS**

Windows has got three basic constituents. They are,

- i. Program manager
- ii. File manager
- iii. Accessories

The program manager is the house keeping program of the whole windows environment. It is always running while in windows and organizes and runs the different programs efficiently. It creates the Icons and controls the windows.

The file manager helps in the normal DOS operations like viewing the directory tree or listing the different files in a directory etc.

The accessories which are supplied along with windows are utility programs which are windows based application programs. Some of them are:

- i. **Paint brush** for creating a picture
- ii. **Write** for editing text
- iii. **Note pad**
- iv. **Clock**
- v. **PIF editor**
- vi. **Calendar**
- vii. **Calculator**
- viii. **Recorder**
- ix. **Terminal**

There are several versions of MS- WINDOWS:

- Windows XP professional edition
- Windows XP home edition
- Windows 2000 professional
- Windows ME
- Windows 98
- Windows NT
- Windows 95

## 5.8 WINDOWS NT

Windows NT has now become a popular operating system for business, scientific and consumer applications. Windows NT facilitates client server computing. Designed around a powerful 32-bit software architecture, the important features of Windows NT are :

- i. **Scalability:** Windows NT has the ability to run on a single PC chip with a single user up to a multi-user, multiprocessor networked installation.
- ii. **Windows GUI:** The GUI is a pseudo object oriented user interface using folders, cabinets etc. to represent files and collection of files.

Windows NT is DOS compatible. A feature comparison of Windows family of operating systems is given in Table 5.3.

**Table. 5.3 Comparison of Features of Windows OS**

<i>Feature</i>	<i>Windows 95/98/Me</i>	<i>Windows NT 4.0</i>	<i>Windows 2000 Professional</i>	<i>Windows XP Professional</i>
System Restore		□	■	■
Device Driver Verifier			■	■
Scalable Memory and Processor Support		■	■	■

*Contd...*

Contd....

<b>Feature</b>	<b>Windows 95/98/Me</b>	<b>Windows NT 4.0</b>	<b>Windows 2000 Professional</b>	<b>Windows XP Professional</b>
File Protection			■	■
Installer	■		■	■
Firewall				■
IP Security			■	■
Smart Card				■
Hardware Standards Support	■		■	■
Unattended Installation	□	□	□	■
System Preparation Tool		□	□	■
IntegratedCD Burning				■
On line Conferencing				■
Power Management			■	■
Hibernation			■	■
Wireless Networking				■
Internet Connection Sharing	□		■	■
Blue Tooth 2.0				■

- Partial Capability  
 ■ Full capability

### 5.8.1 WINDOWS NT ARCHITECTURE

The Kernel mode is the lowest level of Windows NT operation. All physical device control and low level OS control is accomplished in this mode. All subsystems and application codes are run in the user mode. This is distinguished from Kernel mode in several ways. No user mode program may directly access a physical device or process and security protections are in full force in user mode. The parts of NT that implements the whole blocks of functionality like Win 32/2, OS/2, and POSIX etc. are called the sub systems.

The application program interface provides a wide range of functions. The functional categories are :

#### i. Graphics Device Interface (GDI)

This is the part of Win 32 and the kernel that implements display and drawing functions.

**ii. System services and information**

System services are a subset of Win32 that gives applications access to the resources of the computers and the lowest level features of the OS such as memory, console 310, file system drivers etc.

**iii. Multimedia**

NT is becoming a premier platform for high end graphics animation and sound processing.

**iv. Window creation and management**

Window management gives Win 32 applications the means to create and manage a user interface.

**v. Remote procedure calls**

Remote procedure calls give the applications means to carry out distributed computing, letting Win 32 applications tap the resources and computing power of other computers, all of which are linked through a network.

**vi. Win 32 extension**

Win 32 extensions provide services and capabilities beyond the basic services of Win 32. These consist of the following :

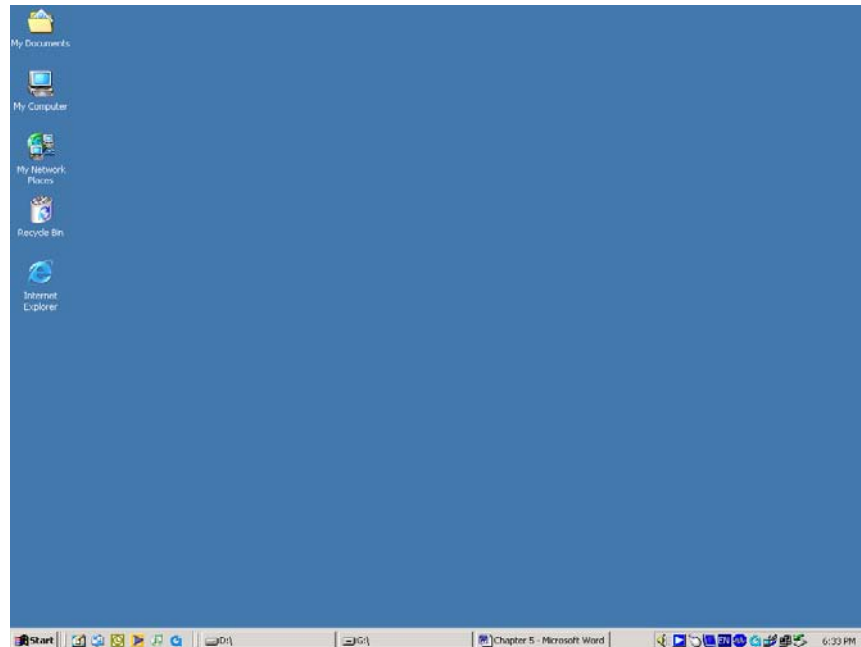
- (a) Common controls and dialog boxes
- (b) Data decompression and file installation
- (c) Dynamic Data Exchange (DDE) and network DDE management
- (d) Shell extension

The network support infrastructure of Windows NT provides transport drives for:

- TCP/IP (Transmission Control Protocol/Internet Protocol)
- NW Link
- Net BEUI (Net BIOS extended user interface)
- DLC (Data Link Control)

**5.8.2 WINDOWS 2000 PROFESSIONAL DESKTOP**

After your computer boots Windows 2000 professional, the screen displayed is the desktop. The desktop replaces the Program Manager interface from earlier versions of Windows and Windows NT. You can create shortcuts to programs you use frequently and place them on the desktop. You can also configure the display properties, such as icon size, background color, screen saver, display resolution, and so on, by right clicking anywhere on the desktop and then clicking Properties. There are several icons on the desktop, as well as a taskbar and a Start button. Figure 5.2 shows Windows 2000 professional Desktop screen.



**Fig. 5.2 Windows 2000 Professional Desktop Screen**

The following is the brief explanation of the Windows 2000 professional user interface.

### **5.8.2.1 My Computer**

Double clicking the My computer icon displays the My Computer window. This window graphically represents every drive on the computer (including network drives, if any), as well as the Control Panel and the Printers folders. If you double-click any icon in the My Computer window, another dialog box is displayed showing the contents of the drive or folder you clicked.

### **5.8.2.2 My Network Places**

The My Network places icon is only displayed if you are using a network. If you double-click the My Network Places icon, a dialog box is displayed that contains an icon for your computer and an icon for the entire network. You can expand the icons in this dialog box to show all computers, shared folders, and shared printers on your network.

### **5.8.2.3 Recycle Bin**

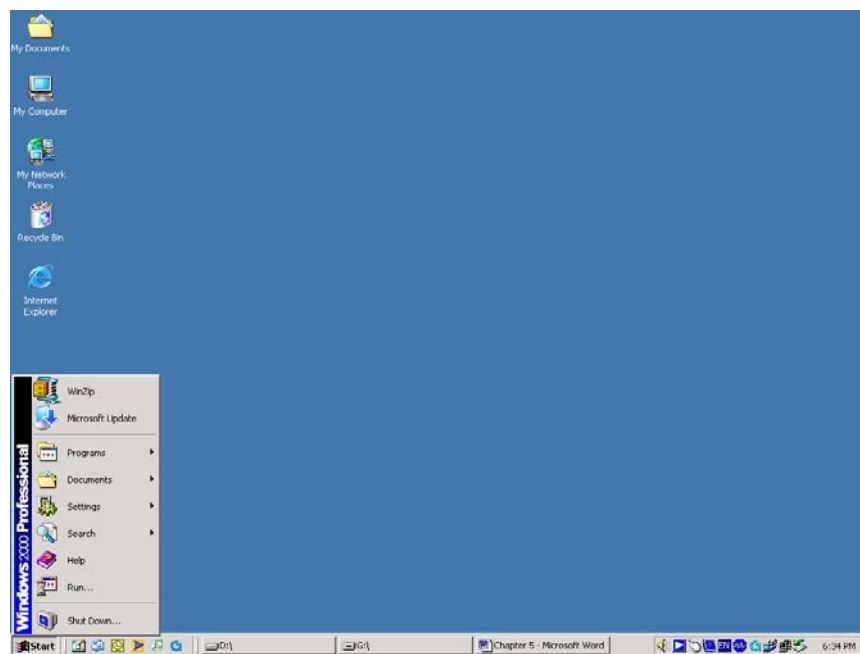
When you delete files, the files are moved from their original location into the Recycle Bin folder. In case you remove a file inadvertently, you can restore that file back by using the “Restore” option in the Recycle Bin menu. When you delete items in the Recycle Bin, the items are removed permanently from your Recycle Bin.

#### 5.8.2.4 Internet Explorer

The Internet Explorer icon appears below the Recycle Bin icon. When you double-click the Internet Explorer icon, Microsoft Internet Explorer starts. You can use this application to browse Web pages on the Internet.

#### 5.8.2.5 Start Button

The Start button is located on the left side of the task bar. Clicking the Start button opens a menu that enables you to quickly access programs, recently used documents, settings (such as the Control Panel and Printers folders), and Help. The menu also enables you to run applications from a command line, find a document, and shut down your computer. The start menu of Windows NT server is shown in Fig. 5.3.



*Fig. 5.3. Start Menu of Windows 2000 Professional*

#### 5.8.2.6 Taskbar

The taskbar at the bottom of the desktop contains the Start button, a button for each program that is currently running, and a clock. You can quickly switch between applications by clicking the button that represents the application you want to access.

#### 5.8.2.7 Close, Minimize and Maximize Buttons

At the upper right-hand corner of every window is a button, marked with an X. This button is called the close button and is used to close the window and exit the application. Many windows have two additional buttons located adjacent to the close button: minimize and



maximize buttons. The minimize button looks like an underscore on a button. Clicking this button will minimize the application to its icon on the taskbar. The maximize button looks like either a single box with a dark line across the top, or like two overlapping boxes, each with a dark line across the top. Clicking the maximize button switches between a small view of the window and a full screen view of the window.

You can also access any file, folder, printer or application on your computer or on the network in Windows 2000 Professional. Windows 2000 Professional is a useful tool for copying, moving and deleting files. To access programs click the "Start" button on the left corner of the taskbar.

Windows 2000 Professional is a high-security capable operating system. Like Windows NT Workstation, user logon and authentication is required. Security is controlled and administered via a domain directory database. Windows 2000 Professional is optimized for server performance. Its client/server platform provides for powerful network features.

## 5.9 LINUX

The concept of open source software is almost as old as commercial software itself. Richard Stallman founded the GNU project in 1983. In 1991 Linus Torwalds wrote a kernel for the open source system which was later named as Linux. Linux is a full featured 32 bit multi user and multitasking operating system and adheres to the common POSIX standards for UNIX. Linux features native TCP/IP support and a mature X Windows GUI interface. It provides a complete development environment for C, C++, and Java etc. As in UNIX all interactions to OS are done through designated "users". Linux is a good, reliable and stable platform for developers. It has several GUI software development interfaces.

### QUESTIONS

1. What are the functions of an operating system?
2. Compare the functionalities of an operating system and an operating environment.
3. Differentiate between control program and processing programs.
4. Describe the architecture of UNIX operating system.
5. Why is UNIX a popular operation system?
6. What is a GUI? Why are GUI's popular?
7. Compare the functionalities in the different windows versions.
8. Make a comparative study of UNIX and Windows NT.

# GEOMETRIC MODELING TECHNIQUES

*Geometric modeling techniques like wire frame, surface and solid modeling have totally changed not only the drawing office practices but also have helped to integrate design with analysis, simulation and optimization as well as to seamlessly integrate design with downstream manufacturing applications. Data created in geometric models can thus be directly passed on to all the application software packages like finite element analysis, mechanism analysis, CNC programming, inspection etc. Geometric modeling has therefore paved the way for CIM. The salient features of the different modeling techniques are discussed in this chapter. The starting point of new product development is conceptual design. The designer has to develop the shape of the product which in turn has to accommodate the functional parts inside. Whether it is a consumer durable like a camera, and an electric iron, a washing machine, an automobile, an entertainment electronic item like television or a sports item like a golf club, shape design is a critical activity in product design. This chapter also discusses conceptual design techniques and transfer of data to modeling software.*

## 6.1 INTRODUCTION

Product development activity starts with the design of the product. As mentioned in Chapter 2 this is a very critical activity which will influence the cost, performance, service life, quality, manufacturability, maintainability etc. The challenges before the product designers today are listed below:

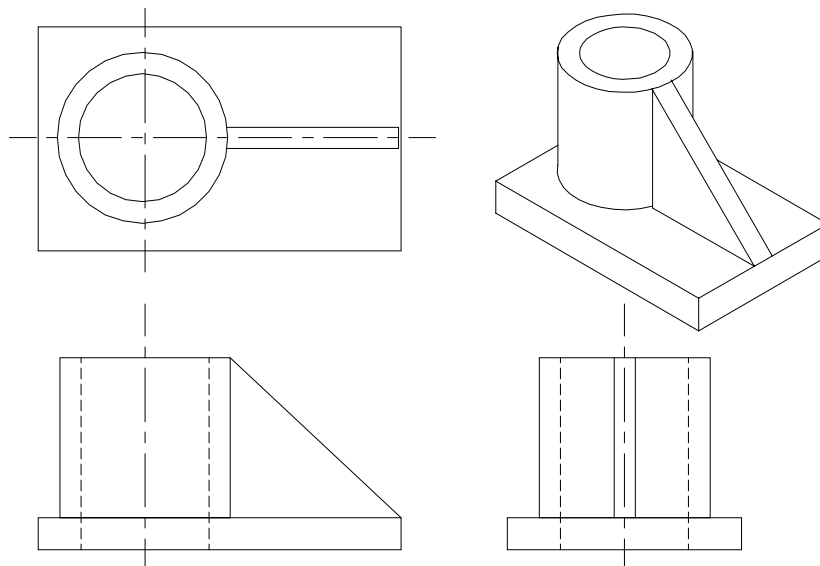
- Higher customer quality expectations
- Need to have innovation and originality in design
- Need for global collaboration across and beyond the enterprise among designers, customers and vendors to reduce development lead times
- Need to evaluate feasibility throughout the design process
- Ability to react quickly to design changes as and when change requests are made
- Ability to express the design intent in terms of shape and function using the tools available as well as the ability of the tools to transfer data back and forth seamlessly.

Manufacturing of machine parts and components is carried out with the help of drawings. The machine operator is provided with the drawing of the finished part and an operation sheet which gives step by step instructions to produce the part. Drawings are also required for process planning, tool design, production planning, and CNC

programming, inspection, assembly, costing and vendor development. Thus, drawings are essential documents for product development as well as for regular production. However, with the introduction of computer integrated manufacturing the importance of drawing as the basic document for product development and manufacture has diminished.

In addition to production drawings of components, the design department has to create layout drawings, assembly drawings, and tool drawings (Jigs, fixtures, templates, special tools, inspection fixtures etc). The number of drawings required for a product varies with the complexity of the product. In the case of the development of a centre lathe, it may be necessary to create about 400-500 drawings. For an aircraft, the number of drawings will be of the order of 30,000 to 60,000. In addition to component drawings, it is necessary to create hundreds of tool drawings and jig and fixture drawings for manufacture, assembly and inspection. Considerable manpower and time will be required to create such a large volume of drawings and the time required for this task represents a significant portion of the lead time required for product development.

Computer aided design and drafting (CADD) is a powerful technique to create the drawings. Traditionally, the components and assemblies are represented in drawings with the help of elevation, plan, and end views and cross sectional views. In the early stages of development of CADD, several software packages were developed to create such drawings using computers. Figure 6.1 shows four views (plan, elevation, end view and isometric view) of a part. Since any entity in this type of representation requires only two co-ordinates (X and Y) such software packages were called two-dimensional (2-D) drafting packages. With the evolution of CAD, most of these packages have been upgraded to enable 3-D representation.



**Fig. 6.1 Four Views of a Part**

## 6.2 GEOMETRIC MODELING

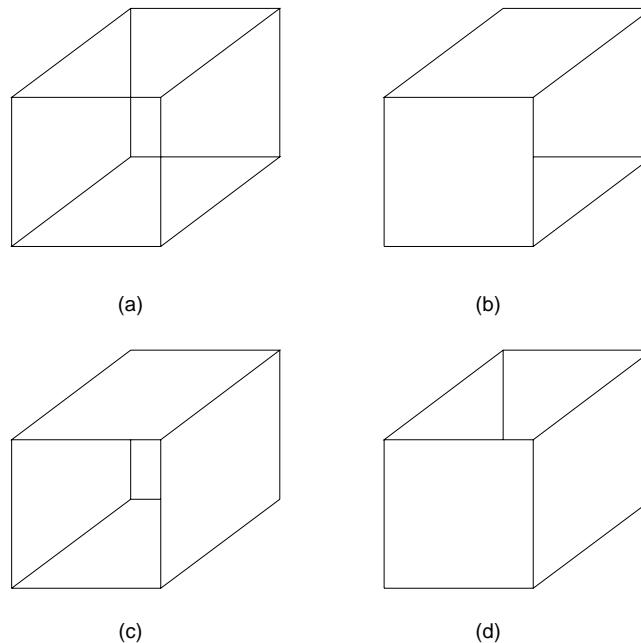
Computer representation of the geometry of a component using software is called a geometric model. Geometric modeling is done in three principal ways. They are:

- i. Wire frame modeling
- ii. Surface modeling
- iii. Solid modeling

These modeling methods have distinct features and applications.

### 6.2.1. WIRE FRAME MODELING

In wire frame modeling the object is represented by its edges. In the initial stages of CAD, wire frame models were in 2-D. Subsequently 3-D wire frame modeling software was introduced. The wire frame model of a box is shown in Fig. 6.2 (a). The object appears as if it is made out of thin wires. Fig. 6.2(b), 6.2(c) and 6.2(d) show three objects which can have the same wire frame model of the box. Thus in the case of complex parts wire frame models can be confusing. Some clarity can be obtained through hidden line elimination. Though this type of modeling may not provide unambiguous understanding of the object, this has been the method traditionally used in the 2-D representation of the object, where orthographic views like plan, elevation, end view etc are used to describe the object graphically.



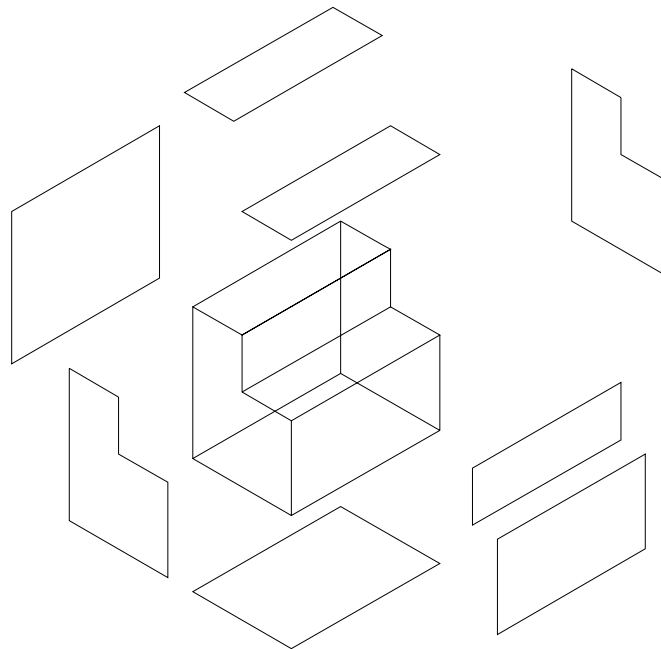
**Fig. 6.2 Ambiguity in Wire Frame Modeling**

A comparison between 2-D and 3-D models is given below:

<b>2 - D Models</b>	<b>3-D Wire Frame Models</b>
Ends (vertices) of lines are represented by their X and Y coordinates	Ends of lines are represented by their X, Y and Z coordinates.
Curved edges are represented by circles, ellipses, splines etc. Additional views and sectional views are necessary to represent a complex object with clarity.	Curved surfaces are represented by suitably spaced generators. Hidden line or hidden surface elimination is a must to interpret complex components correctly.
3-D image reconstruction is tedious.	2-D views as well as various pictorial views can be generated easily.
Uses only one global coordinate system	May require the use of several user coordinate systems to create features on different faces of the component.

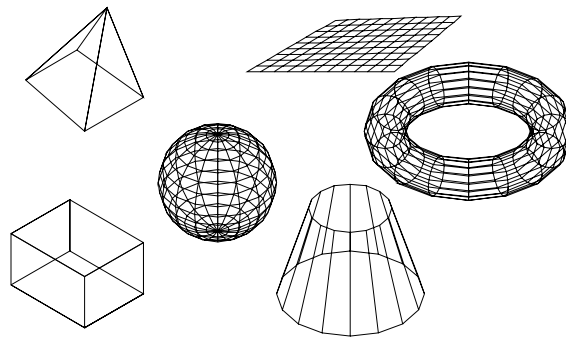
### 6.2.2. SURFACE MODELING

In this approach, a component is represented by its surfaces which in turn are represented by their vertices and edges. For example, eight surfaces are put together to create a box, as shown in Fig. 6.3. Surface modeling has been very popular in aerospace product design and automotive design. Surface modeling has been particularly useful in the development of manufacturing codes for automobile panels and the complex doubly curved shapes of aerospace structures and dies and moulds.



**Fig. 6.3 Surface Representation**

Apart from standard surface types available for surface modeling (box, pyramid, wedge, dome, sphere, cone, torus, dish and mesh) techniques are available for interactive modeling and editing of curved surface geometry. Surfaces can be created through an assembly of polygonal meshes or using advanced curve and surface modeling techniques like B-splines or NURBS (Non-Uniform Rational B-splines). Standard primitives used in a typical surface modeling software are shown in Fig. 6.4. Tabulated surfaces, ruled surfaces and edge surfaces and revolved are simple ways in which curved geometry could be created and edited. Surface modeling is discussed in detail later in this chapter.



**Fig. 6.4 Typical Approaches in Surface Modeling**

### 6.2.3. SOLID MODELING

The representation of solid models uses the fundamental idea that a physical object divides the 3-D Euclidean space into two regions, one exterior and one interior, separated by the boundary of the solid. Solid models are:

- bounded
- homogeneously three dimensional
- finite

There are six common representations in solid modeling.

- Spatial Enumeration:** In this simplest form of 3D volumetric raster model, a section of 3D space is described by a matrix of evenly spaced cubic volume elements called voxels.
- Cell Decomposition:** This is a hierarchical adaptation of spatial enumeration. 3D space is sub-divided into cells. Cells could be of different sizes. These simple cells are glued together to describe a solid object.
- Boundary Representation:** The solid is represented by its boundary which consists of a set of faces, a set of edges and a set of vertices as well as their topological relations.
- Sweep Methods:** In this technique a planar shape is moved along a curve. Translational sweep can be used to create prismatic objects and rotational sweep could be used for axisymmetric components.

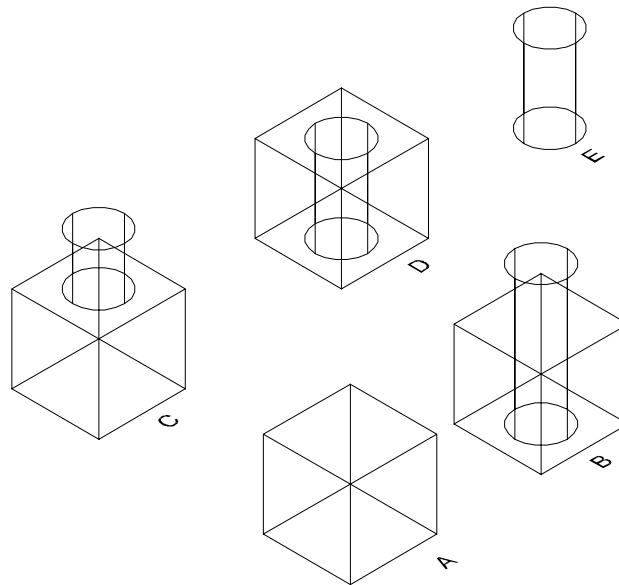
- v. Primitive Instancing: This modeling scheme provides a set of possible object shapes which are described by a set of parameters. Instances of object shape can be created by varying these parameters.
- vi. Constructive Solid Geometry (CSG): Primitive instances are combined using Boolean set operations to create complex objects.

In most of the modeling packages, the approach used for modeling uses any one of the following three techniques:

- i. Constructive solid geometry (CSG or C-Rep)
- ii. Boundary representation (B-Rep)
- iii. Hybrid method which is a combination of B-Rep and CSG.

### 6.2.3.1 Constructive Solid Geometry (CSG)

In a CSG model, physical objects are created by combining basic elementary shapes known as primitives like blocks, cylinders, cones, pyramids and spheres. The Boolean operations like union ( $\cup$ ), difference ( $-$ ) and intersection ( $\cap$ ) are used to carry out this task. For example, let us assume that we are using two primitives, a block and a cylinder which are located in space as shown in Fig. 6.5.



**Fig.6.5 CSG Operation**

A “union” operation ( $A \cup B$ ) will combine the two to convert them into a new solid. (Fig. 6.5 (c)) The difference operation ( $A - B$ ) will create a block with a hole (Fig. 6.5. (D)). An intersection operation ( $A \cap B$ ) will yield the portion common to the two primitives. (Fig. 6.5(E)).

### 6.2.3.2 Boundary Representation

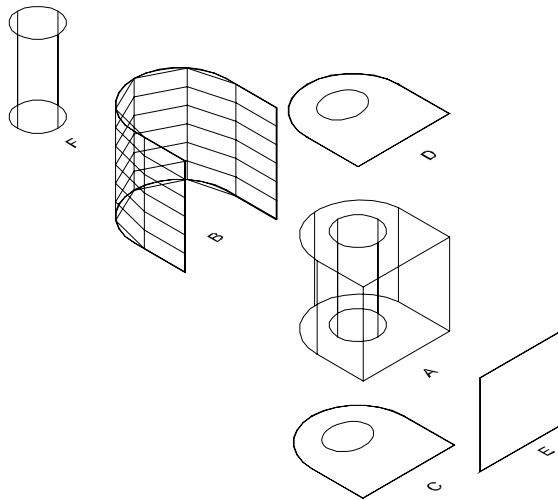
Boundary representation is built on the concept that a physical object is enclosed by a set of faces which themselves are closed and orientable surfaces. Fig. 6.6 shows a B-rep model of an object. In this model, face is bounded by edges and each edge is bounded by vertices. The entities which constitute a B-rep model are:

#### **Geometric entities**

Point  
Curve, line  
Surface

#### **Topological entities**

Vertex  
Edge  
Face



**Fig. 6.6 B-Rep Model**

A solid model is a 3-D representation of an object. It is an accurate geometric description which includes not only the external surfaces of part, but also the part's internal structure. A solid model allows the designer to determine information like the object's mass properties, interferences, and internal cross sections.

Solid models differ from wire frame and surface models in the kind of geometric information they provide. Wire frame models only show the edge geometry of an object. They say nothing about what is inside an object. Surface models provide surface information, but they too lack information about an object's internal structure. Solid models provide complete geometric descriptions of objects.

Engineers use solid models in different ways at different stages of the design process. They can modify a design as they develop it. Since computer-based solid models are a lot



easier to change and manipulate than the physical mock-ups or prototypes, more design iterations and modifications can be easily carried out as a part of the design process. Using solid modeling techniques a design engineer can modify a design several times while optimizing geometry. This means that designers can produce more finished designs in less time than by using traditional design methods or 2-D CAD drafting tools.

Solid models can be used for quick and reliable design analysis. Solid models apart from geometric information provide important data such as volume, mass, mass properties and centre of gravity. The designer can also export models created to other applications for finite element analysis (FEA), rapid prototyping and other special engineering applications.

Finally designers can generate detailed production drawings directly from the solid model. This capability increases design productivity considerably. Another important feature of solid modeling is associativity. Detailed drawings are linked to solid model through the associativity feature. This is a powerful function - as an engineer modifies a design, the drawings get updated automatically. In bidirectional associativity, any modifications made to geometry in the drawing are reflected in the model. In more advanced design and manufacturing environments, solid models are used for rapid prototyping and automated manufacturing applications.

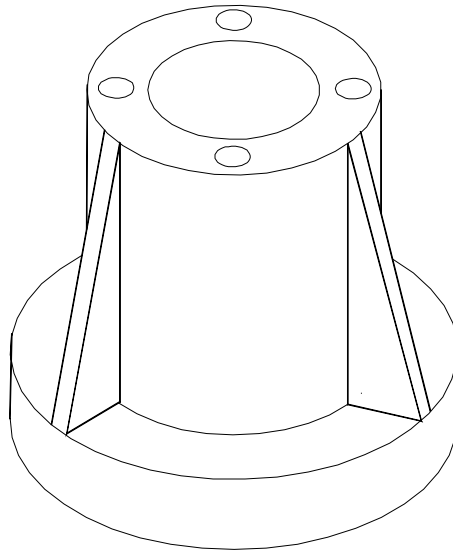
The salient features of the solid modeling approach to design are discussed in the following sections.

## **6.3 SALIENT FEATURES OF SOLID MODELING**

### **6.3.1. FEATURE-BASED DESIGN**

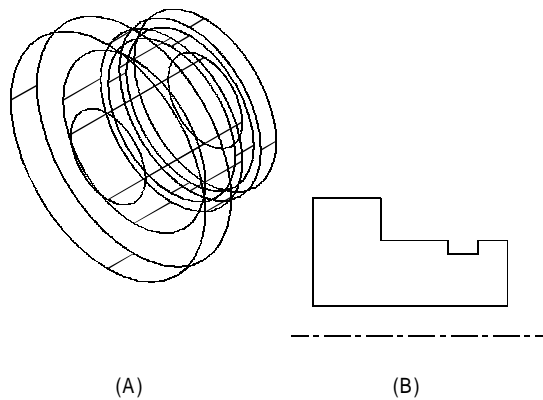
The most fundamental aspect in creating a solid model is the concept of feature-based design. In typical 2-D CAD applications, a designer draws a part by adding basic geometric elements such as lines, arcs, circles and splines. Then dimensions are added. In solid modeling a 3-D design is created by starting a base feature and then adding other features, one at a time, until the accurate and complete representation of the part's geometry is achieved.

A feature is a basic building block that describes the design, like a keyway on a shaft. Each feature indicates how to add material (like a rib) or remove a portion of material (like a cut or a hole). Features adjust automatically to changes in the design thereby allowing the capture of design intent. This also saves time when design changes are made. Because features have the ability to intelligently reference other features, the changes made will navigate through design, updating the 3-D model in all affected areas. Figure 6.7 shows a ribbed structure. It consists of feature like ribs and holes.



**Fig. 6.7 A Ribbed Structure**

Similarly, if a flanged part shown in Fig. 6.8 (A) is to be created, the one approach is to sketch the cross section as shown in Fig. 6.8 (B) and then revolve through  $360^\circ$ .



**Fig. 6.8 Flanged Part**

In typical solid modeling software the designer can create a feature in two basic ways. One is to sketch a section of the shape to be added and then extrude, revolve, or sweep it to create the shape. These are called sketched features.

Another type of feature is the pick-and-place feature. Here the designer simply performs an engineering operation such as placing a hole, chamfering or rounding a set of edges, or shelling out the model.

An important component of every feature is its dimensions. Dimensions are the variables that one changes in order to make the design update automatically. When a dimension is changed the solid modeling software recalculates the geometry.

Design of a part always begins with a base feature. This is a basic shape, such as a block or a cylinder that approximates the shape of the part one wants to design. Then by adding familiar design features like protrusions, cuts, ribs, keyways, rounds, holes, and others the geometry of a part is created.

This process represents true design. Unlike many CAD applications in which designing means drawing a picture of the part, working with the feature-based solid modeling method is more like sculpting designs from solid material.

Features/available in typical solid modeling software are:

Extrude	Revolve	Thin
Blend	Slot	Cut
Protrusion	Shaft	Round
Hole	Flange	Rib
Chamfer	Push	Dome
Draft	Ear	Shell
Offset	Lip	
Pipe	Sweep	

### 6.3.2. MODELING TOOLS

When a 3-D model is built the designer describes the features that make up a part. Parts are put together to make an assembly, and then documentation is made.

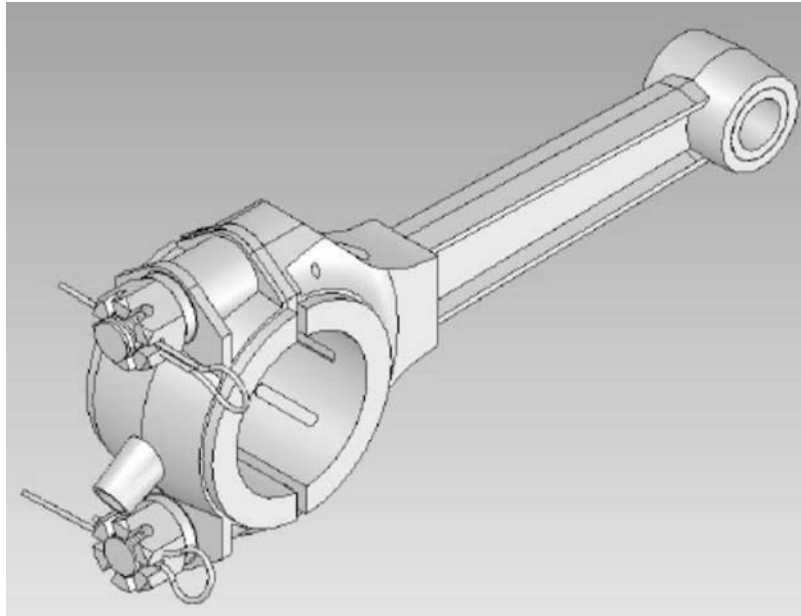
#### **Sketching**

The first step in creating many 3-D features is sketching a 2-D section. Then by using appropriate instructions the design conveys the information regarding how far to extend this section in a space. The third dimension is created this way. For instance, a 30 mm circle extruded 50 mm through space produces a cylinder 30 mm diameter and 50 mm high. The circle is the sketched section of the cylinder.

#### **Creating Parts**

As mentioned earlier solid modeler uses features such as cuts, protrusions, holes, chamfers, and other basic shapes to build part geometry. The designer gets the information about the geometry of a feature (like the size and shape of cuts and protrusions), from a sketcher window.

As the features are added the geometry of the part is enhanced. By adding to geometry one feature at a time, parts with very complex geometry can be created as shown in Fig. 6.9.

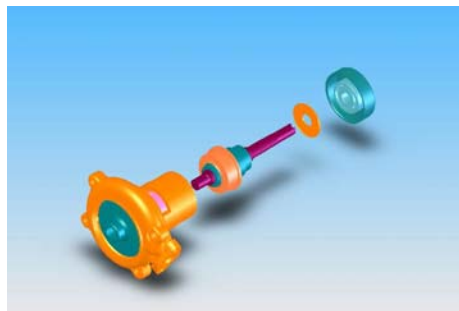


**Fig. 6.9 Part with Complex Geometry**

Many tools for modifying geometry, establishing relations between features, and defining or modifying feature attributes are provided in solid modeling softwares. Regardless of whether simple parts or complex ones are designed, part geometry is created and modified in the same way.

### **Building Assemblies**

Designs usually consist of several parts. Solid modelers can put two or more parts together in an assembly. All the tools a designer needs to build, modify, and verify assemblies are available in solid modeling softwares.



**Fig. 6.10 Exploded View of an Assembly**

### ***Documenting Designs***

The final step of designing a part or assembly is communicating it in a medium other than the computer monitor's display. For some operations this means plotting out design drawings. Solid modelers provide tools to produce finished drawings complete with geometric tolerancing and text annotation.

Drawings may not be the final step for everybody. Many users export designs to other applications for analysis, manufacturing, and other forms of post-processing. Modeling software also will incorporate a variety of tools for exporting designs to other softwares.

### **6.3.3 CHARACTERISTICS OF SOLID MODELING PACKAGES**

Several important characteristics of solid modeler make them capable of creating designs faster. These include parametric design, the ability to establish relations and the ability to build assemblies.

#### **6.3.3.1 Parametric Design**

When a feature is created in a solid modeler dimensions are created. These dimensions do more than show the size of the feature. They define parameters that control part geometry. Since parameters control geometry, the geometry is said to be dimension driven.

Parameters can be driven by dimensional values, or they can be driven by other parameters using a relation. For instance, the length parameter of a feature is set up so that it is always twice the width parameter. If the width changes, the length will change too.

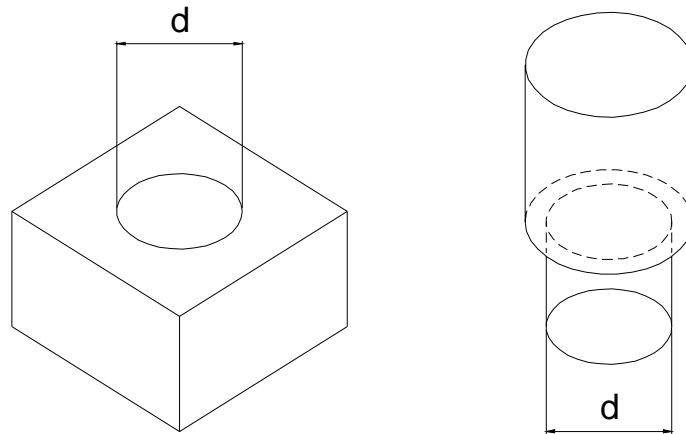
There are other kinds of values that can be used as parameters. A formula that relates specific feature geometry to volume, temperature, stress, weight, and other properties can also be used in parametric designs.

When parameters change, other parameters driven by the modification also change. This is the essence of parametric design.

#### **6.3.3.2 Relations and Relationships**

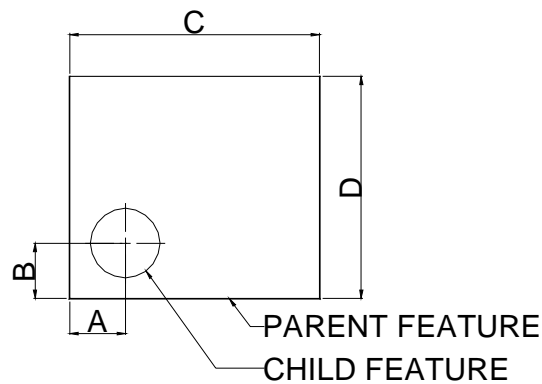
Solid models provide two fundamental ways to relate elements of geometry to one another within a design. One is as already mentioned i.e. setting up relations between parameters.

The length to width example just described shows a simple application of parametric relations. Another example that gives a better idea of the power of relations is shown in Fig. 6.11. Within an assembly, the designer can define a relation such that the diameter of a bore in one component part always equals the diameter of a shaft, plus a clearance value, on another part. This relation ensures that the parts always fit in an assembly, even if the diameter of the shaft changes. If the design engineer modifies the diameter of the shaft, the diameter of the bore automatically changes to accommodate it.



**Fig. 6.11 Parametric Relation Between a Hole in One Component and a Shaft in Another**

Another way to relate geometry within a design is to create a parent/child relationship. There are many ways to do this. One is to simply create a dimension parameter between a new feature and an existing one. The new feature becomes the child of the existing parent feature.

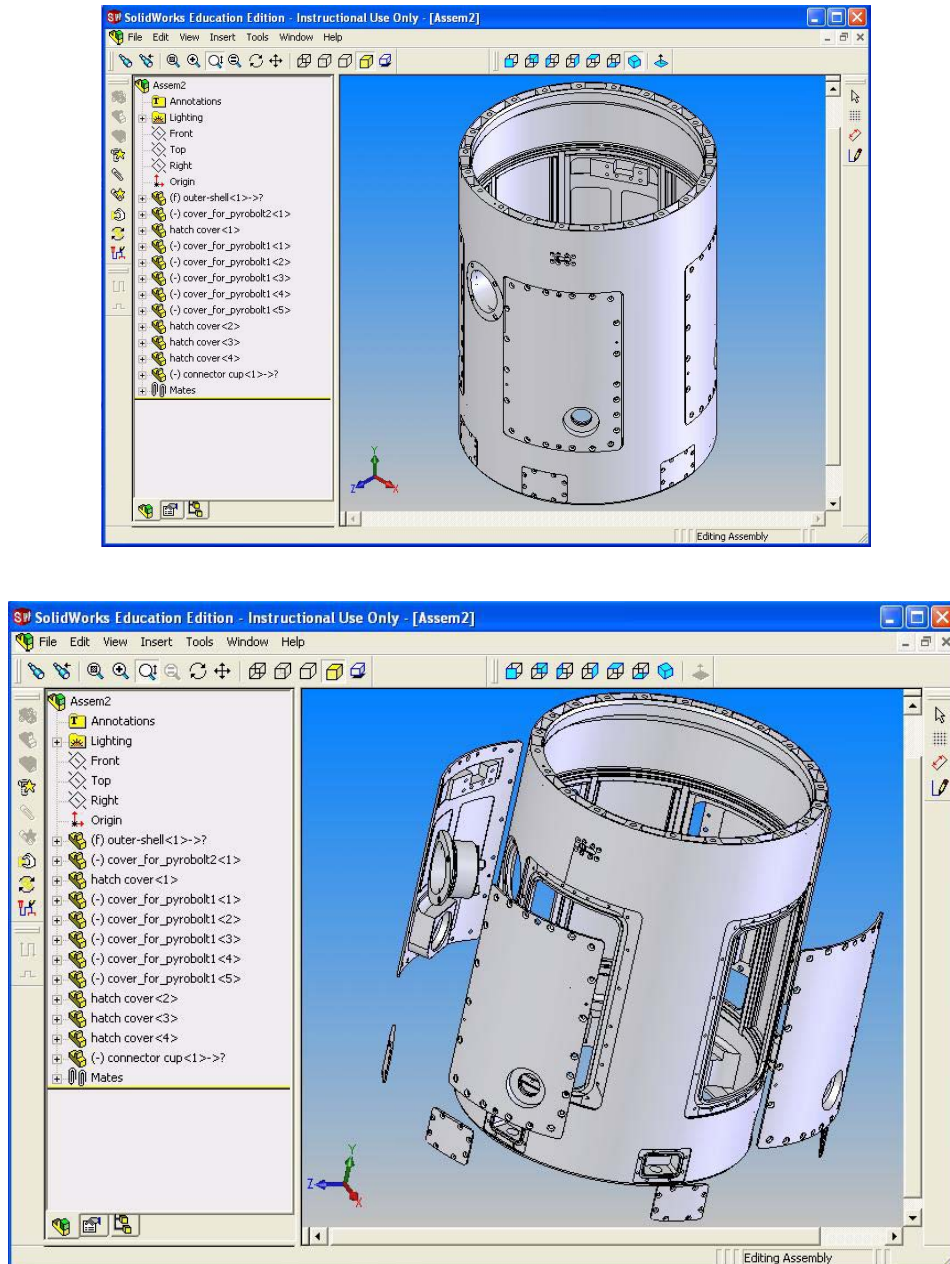


**Fig. 6.12 Parent-Child Feature**

Parent/child relationships can be very useful. If the geometry of a parent changes, the child features are updated with it. Although parent/child relationships enhance the parametric behaviour of the designs, they should only be used appropriately. Creating parent/child relationships where there should be none can cause the design to behave in ways the designer did not intend.

Solid modeling is capable of combining parts into an assembly. These modelers provide all the tools that are needed to orient, align, and mate parts. The designer can remove parts from assemblies, modify part geometry, and establish relations between assembly components. In addition, local and global interferences can be checked.

This ability to create a fully parametric assembly makes solid modeling software a very powerful design tool. With the aid of solid modeling a designer can build extremely complex, multi-component designs (Fig. 6.13).



**Fig. 6.13 Assembly Made up of Several Parts (Top); Exploded View of the Assembly (Bottom)**

All designs, whether big or small, begin with an idea. As the idea takes form, so do certain aspects of the idea. What is the purpose of the design? What are the key features and components that make the design achieve its objectives? How do the components fit together? And what other questions are to be satisfactorily answered to make it a viable design? These are some of the issues the designer has to answer while carrying out a design.

### 6.3.3.3 Behaviour Modeling

Behavior modeling is the latest development in mechanical CAD. It gives the designers more efficient and adaptable ways of creating designs. It helps to synthesize required functional behavior, design context and geometry. Through an intelligent process of knowledge capture and iterative solving behavior modeling allows engineers to pursue highly innovative and robust designs. The process of behavior modeling involves:

**Smart models:** These encapsulate engineering intelligence. Designs are created using feature based techniques, which capture geometry, specifications, design intent, and process knowledge-all at the design level.

**Engineering objective based design:** Design tools use feature based design specifications within the smart model to drive and adapt product design. Using objective driven functions, engineers can arrive at an optimum design, even in designs with several variables and constraints and multiple objective criteria.

**Open extensible environment:** This facilitates associative bi-directional communication to any external application like analysis, manufacturing etc. at the feature level of the design ensuring that model reflects the changes incorporated in other applications.

Behavior modeling helps to create designs which are more innovative, differentiable and more responsive to customers' requirements. With the help of objective driven design process engineers can focus on key design issues, and evolve optimal design solutions for better performance and functionality.

Behavior modeling helps to make electronic product designs more complete.

Behavior modeling strategy advances feature-based modeling to accommodate a set of adaptive process features that go beyond the traditional core geometric features. These features accommodate a variety of information that further specifies the intent and performance of the design. There are two distinct categories of adaptive design. Application features describe process information. Behavioral features contain engineering and functional specifications. Application features encapsulate product and process information. Behavioral features define component assembly connectivity, using welds, or pins or slider joints. When behavioral features consist of assembly connectivity information, including any assembly constraints, the assembly design process automatically implements that information to execute functional behavior and purpose. By capturing original design intent, product designs retain their integrity, robustness, and performance while adapting to market and engineering changes. The adaptive process features make smart models highly flexible. As the engineers make changes to the smart models, the models regenerate to accommodate all their features and context. This highly flexible adaptation makes smart



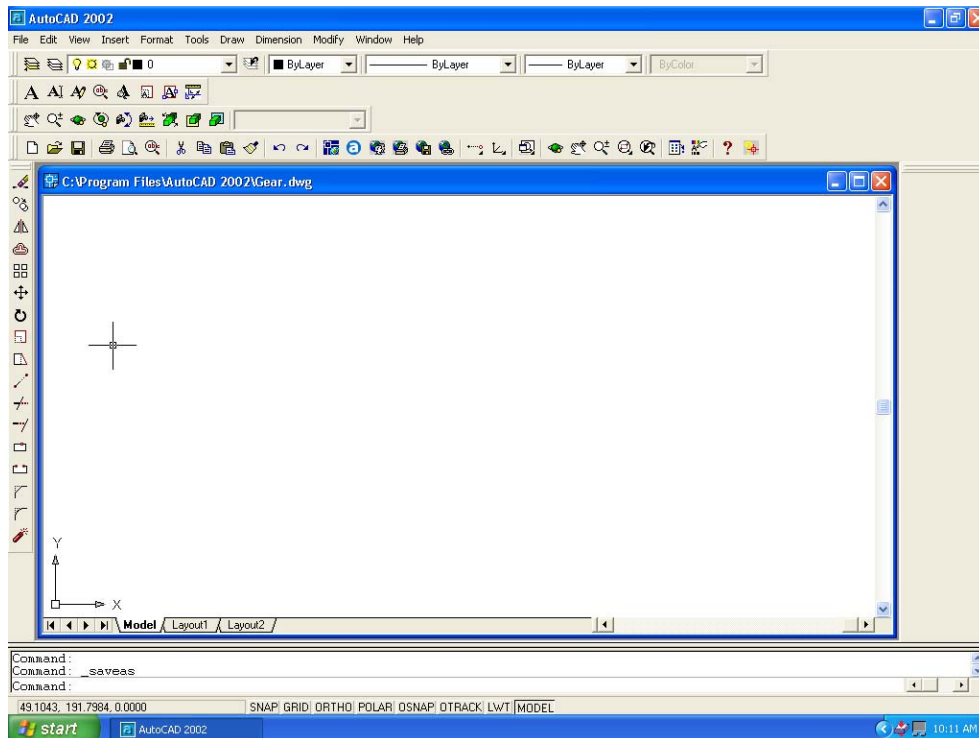
models to respond to changes in their environment.

Objective driven design automatically optimizes designs to meet any number of objectives captured in the smart model by adaptive process features. It can automatically resolve conflicting objectives. In smart models the specifications can be used to drive the design process.

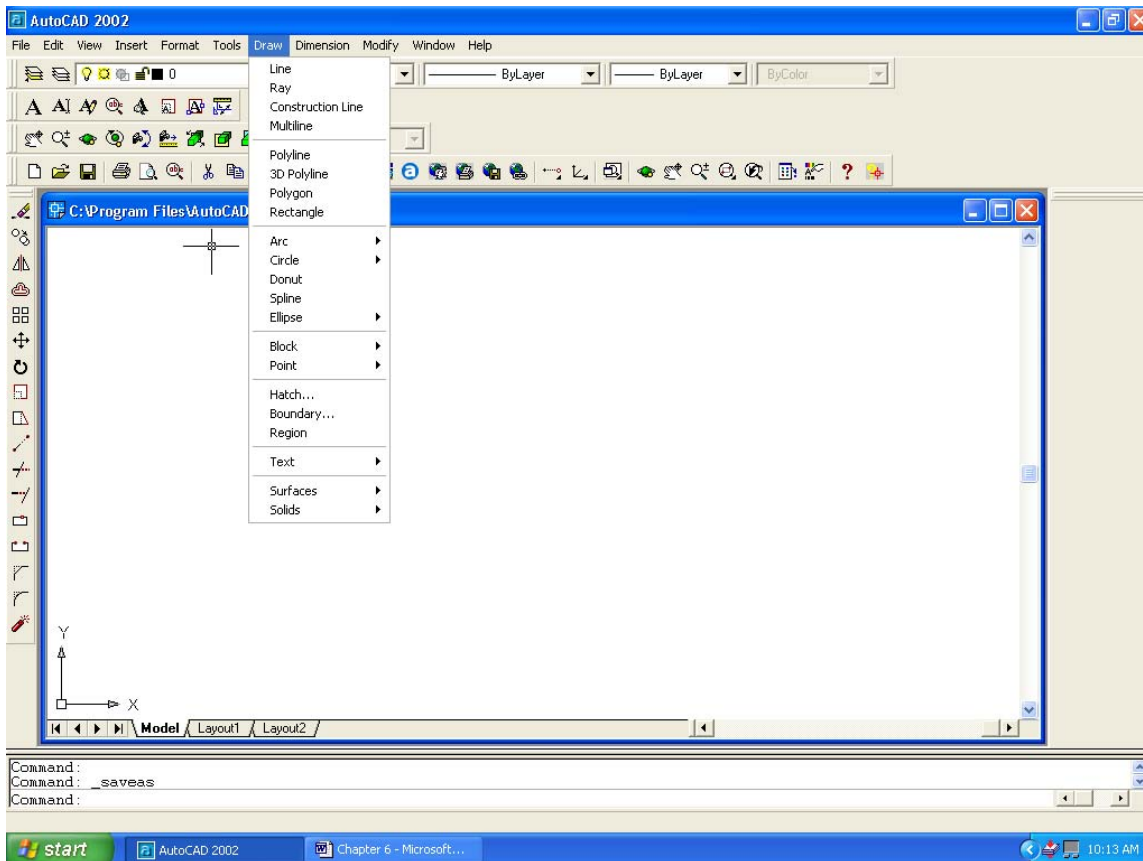
## 6.4 COMMAND, MENU AND ICON DRIVEN SOFTWARES

Commands are the instructions to be input into the package to create a drawing. These commands can be typed on the keyboard. The commands can be selected from a menu which is displayed on a screen or which can be picked from a tablet. Fig. 6.14 shows a typical screen menu. Picking menu using a mouse from the screen menu is fast. Commands can be selected from pull down menus which are displayed at a fixed location on any location of choice by the user (Fig. 6.15).

Modeling software may work in an interactive mode. If a command is issued, say to draw a line, the software may issue a prompt: "From point". If you input the co-ordinate data to specify the starting point of the line, the software returns another prompt: "To point" to indicate that the software is looking for the co-ordinates of the end point. Similarly, other commands are also designed to be executed interactively. More often, the designer selects the end points on the screen using the pointing device with the help of display of coordinate positions.



**Fig. 6.14 Typical Screen Menu**



**Fig. 6.15 A Sub-menu Appearing on the Screen**

The software packages incorporate on-line documentation which is often referred to as a “HELP” feature. In case the user is in doubt about a command, the user can access the documentation to know the correct usage of the command.

**Common types of menu are:**

**Screen Menu:** This menu is usually displayed on a part of the graphics screen. Instead of the mouse, the arrow keys of the keyboard can also be used as a pointing device.

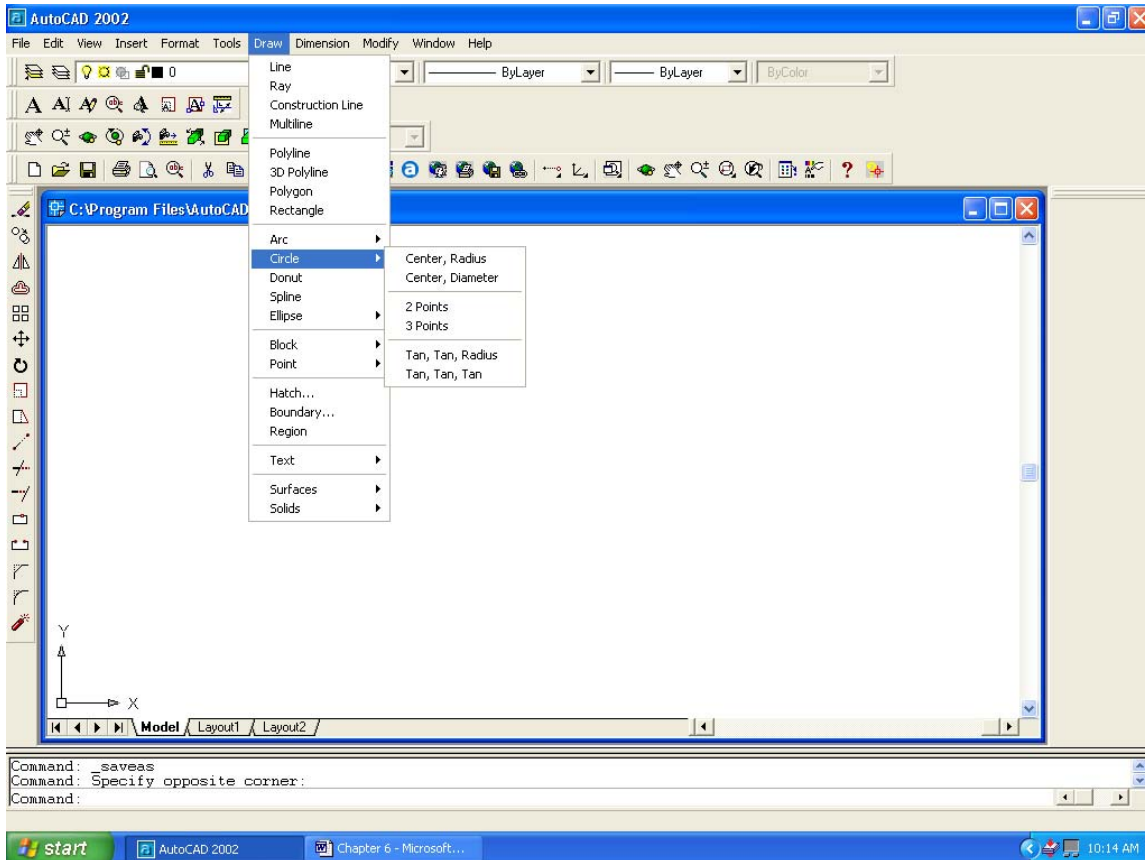
**Tablet Menu:** The menu can be placed in a graphic tablet and the tablet can be configured suitably. A command can be entered into the computer by pointing to it with the digitizer puck or stylus.

**Button Menu:** The tablet puck or mouse may have a number of extra buttons which can be used to enter frequently used commands.

**Pull-down Menu:** Commands can be selected using menu items which can be “Pulled down” from a menu bar usually located at the top of the screen.

**Icon Menu:** An icon menu displays menu in a pictorial form.

Menu is generally organized in a hierarchical manner. For example, the selection process to draw a circle starts with the root menu. From the root menu one selects the “DRAW” menu. The next menu displays various options available in the DRAW menu. If we select the “CIRCLE” from this we get four options. We can select any one of these depending upon how we are going to draw the circle. The menu traversal is shown below:



**Fig. 6.16 Menu Traversal**

A user can customize the menu depending upon the design requirements. Such a customized menu makes a modeling session more productive. Special software agents could be designed to increase design or drafting productivity further. Additional menu items can be incorporated using the programming features available in the software.

## 6.5 FEATURES OF A DRAFTING PACKAGE

Typical features that one expects in a drafting package are listed below:

- i. **Drawing utilities:** This includes selection of units, screen limits, scale, snap, grid, layers etc.

- ii. **Entity drawing:** Several standard entities like line, circle, arc, polyline, polygon, ellipse etc are available to create the model required.
- iii. **Edit commands:** A number of commands are available to modify or copy or replicate the entities or groups of entities in a model.
- iv. **Standard parts:** Facilities are available to create symbols, shapes, and other standard parts. Frequently used parts can be stored as blocks which can be inserted into a drawing as and when required.
- v. **Display:** The model can be enlarged, reduced in size, or moved across the screen, using display commands.
- vi. **Cross hatching:** Sectional plans can be indicated through cross hatching.
- vii. **Dimensioning:** Parts can be dimensioned using a number of standard dimensioning systems.
- viii. **Plotting:** Facilities to get hard copies of drawings using a pen or electrostatic plotter and printer will be available.
- ix. **Configuration:** A software has to be configured to a given hardware environment.
- x. **Customization:** Drafting productivity can be enhanced through customizing software package.
- xi. **Drawing interchange:** It may be necessary to import or export drawing files created in one software package to another. Facilities should be available to carry out this task. This is usually carried out by a post processor to convert the model into a neutral file like STEP and pre-processor to read the STEP file and convert the data into the model.

These features are discussed in detail in the following sections.

## 6.6 DRAWING UTILITIES

Drawing utilities include several functions to help the creation and storage of drawings. These are discussed below:

### 6.6.1 SCREEN SIZE

Generally the screen is given a default size but the size can be modified as per the requirements. This facility is available in all softwares because various sizes of drawings and figures will have to be created. Assembly drawings may require larger sizes whereas part drawings require only smaller sizes. When the command for fixing the drawing limits are invoked the values of the co-ordinates at the bottom left corner and the top right corner are specified as answer to the queries. Alternatively, the size of the drawing sheet (A4, A3, A2, A1 or A0) can be specified. Automatically the software re-fixes the size of the screen. Default screen sizes and standard layouts are also incorporated in the design packages.

### **6.6.2 SCALING**

It may be necessary to fit a large sized drawing within a smaller drawing sheet size. The dimensions can be automatically scaled for this purpose.

### **6.6.3 GRID**

A grid facility is provided by the software to help the designer to estimate distances on the screen. A grid is a matrix of points on the screen whose intervals can be chosen as required. The grid display can be switched on or off and this does not appear while making a hard copy of the drawing.

### **6.6.4 SNAP**

The drawing is created with the help of a cursor. The smallest movement of the cursor is one pixel. The cursor can be moved through a specific distance using SNAP feature. The snap interval can be chosen as described or can be made equal to grid interval. The snap mode can also be switched on or off as desired.

### **6.6.5 UNITS**

Different types of units are used for different applications. Examples are metric units and inch units. The dimension format may be scientific, decimal, engineering, architectural or fractional. Angles can be specified in decimal degrees, degree/minute/seconds or radians.

### **6.6.6 SPECIFYING POINTS**

A point can be specified using the following formats:

- i. Cartesian co-ordinates
- ii. Polar co-ordinates
- iii. Spherical co-ordinates
- iv. Cylindrical co-ordinates
- v. Relative co-ordinates

### **6.6.7 LINE TYPES, TEXT FONTS AND SHAPES**

In a drawing several types of lines will be used and these types are already available (a library) and are given some designation by the software. The default will be the generally used type of line, but as per the requirement the type of line can be chosen before any line is drawn. Softwares also provide simple methods to create and add a new type of line to the library of line types.

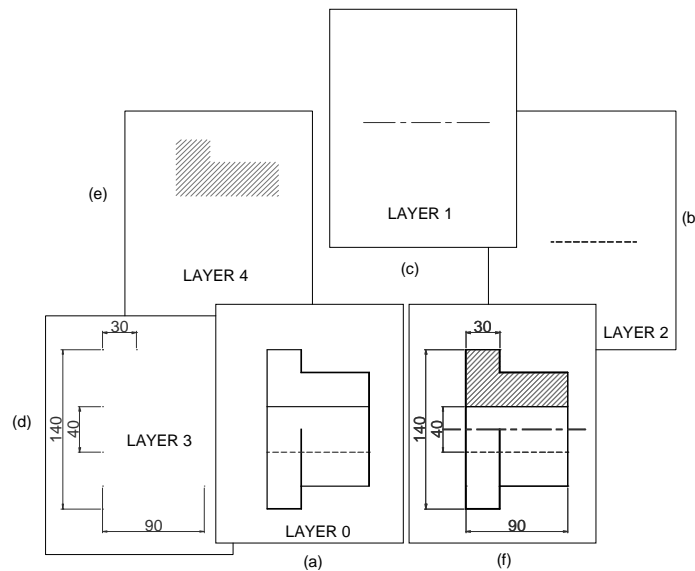
Similarly, texts to be added may be chosen from a library of fonts (standard, Italic, Complex, Simplex, Roman, Byte etc.) and before any text is added this choice has to be made. The text size and the alignment of the text, and the starting and end points of text may also be chosen. It may also be possible to left justify, centre justify and right justify the text. New symbols can be also created and a library of shapes (with names) can be compiled.

These shapes can be called and inserted at any location after suitable scaling and rotation. This is very useful in drawing where symbols are used extensively, say in the case of an oil hydraulic circuit.

**6.6.8 LAYERS**

Layers are an important facility available in all software packages. A drawing contains many sets of details which may be overlaid to create a complex drawing. There are several uses for this facility. A very common example is an assembly drawing consisting of several components. Each component part or sets of similar parts may be drawn on a separate layer so that these can be accessed separately. As far as the screen display is concerned, all layers will be exactly overlaid and all of them can be seen together or some or other can be switched off from display.

All of them can be plotted together or details on each layer can be plotted separately. A separate data file, is generated for each layer and the file will exist separately. Fig. 6.17 shows an example of different entities of a screen drawn in different layers. Before commencing the drawing the layers are created as given below:



**Fig. 6.17 Creation of Layers**

<b>Layer Name</b>	<b>Colour</b>	<b>Linetype</b>
0	Default	Continuous line
1	Red	Centre line
2	Yellow	Continuous line
3	Cyan	Dashed line

The part of drawing shown in Fig. 6.17(a) is drawn in Layer 0. Then layer 1 is set and the centre line shown in Fig. 6.17(b) is drawn in layer 1. The entities drawn on layer 0 will also be visible. For the sake of clarity they are not shown in Fig. 6.17(b).

Similarly hatching is drawn in layer 2 (Fig. 6.17(c)) and the dimensions in layer 3 as shown in Fig. 6.17(d). All the layers are superimposed and the drawing will look like as shown in Fig. 6.17(e). Only one layer can be set at any given time. A layer can be given a specific name. A number of layers can be used in a drawing. It is possible to use more than one color and one line type in a layer. However it is better to use only one color and one line type in a layer. A layer can be switched on or off as and when needed. When a layer is switched off the contents of that layer are not displayed on the screen.

### 6.6.9 SAVING A DRAWING

After a drawing is created it is saved with a file name. The drawing file may have extensions like .PRT or .DWG.

### 6.6.10 FILE UTILITIES

Drafting softwares offer the following file utilities:

- Directory service
- Delete files
- Rename files
- Copy files
- Unlock files
- Edit a file

In addition, it is normally possible to access the operating system commands during a drafting session.

## 6.7 ENTITIES

A drawing is created using a number of entities. A large number of options are provided to draw the entities depending upon the requirements. The common entities used for drafting are listed below:

Point	Arc
Line	Trace
Circle	Polyline (2D & 3D)
Polygon	Doughnut
Ellipse	Solid

Some drafting packages use constraint based construction method. Fixing constraints allows interactive creations of variants.

## 6.8 EDIT COMMANDS

It is necessary to make alterations to the entities of a drawing. EDIT commands are used for this purpose. A list of EDIT commands and their functions are given below:

<i>Command Name</i>	<i>Function</i>
ERASE	Erase a single entity or a group of entities.
OOPS	To retrieve objects erased inadvertently.
MOVE	Move objects to a new location.
ARRAY	Make multiple copies of an object in rectangular or circular pattern.
CHANGE	Change properties like color, layer, thickness, line type, length or location of entities.
BREAK	Break an existing entity into pieces.
MIRROR	Create mirror images of existing objects.
EXPLODE	Explode a block or polyline into its component parts.
ROTATE	Rotate an existing object through a specified angle.
CHAMFER	Chamfer corners of objects.
FILLET	Provide radius of objects.
STRETCH	Modify a part or drawing by stretching the objects connected to it.
OFFSET	Draw parallels to lines or existing curves.
UNDO	Undo a specified number of commands.
TRIM	Trim portion of entities.
EXTEND	Extend an entity to another entity.
COPY	Make single or multiple copies of an existing object.
SCALE	Enlarge or shrink an object.

In addition commands are available to fit curves or spline polylines, divide an entity, sketch an irregular curve etc. Many editing commands like array, copy, offset and mirror increase drafting productivity appreciably.

## 6.9 BLOCKS AND SYMBOLS

Several objects like fasteners, standard parts, parts of jigs and fixtures, etc. are frequently incorporated in drawings. It is a waste of time to draw the repeatedly every time these are



used in drawings. A facility like block can be used for this purpose. A block is a group of entities stored as a drawing file with a specific file name.

The block has a certain reference (insertion) point and an angular position. Any block can be inserted (INSERT command) into the drawing by indicating where the insertion point is to be located. The block can be scaled and rotated when it is being inserted into a drawing. Blocks can be revised and the drawing can be updated with the revised block.

It is also possible to create small objects, called shapes (within the drawing). These can also be called and inserted at any location in a drawing just like a block. A good drafting software should have this facility particularly for specialized drawings where small elements are repeatedly drawn (example: oil hydraulics, electrical schematics, electronic circuits, surface roughness symbols, geometric tolerance symbols, weld symbols etc).

A standard parts library can be created using parametric programming facilities available in the design software packages. Many software packages also provide interface to high level languages like C to create such symbols.

## 6.10 DISPLAY

Display commands are useful to manipulate the drawings on the screen. A frequently used display command is ZOOM. A drawing or parts of a drawing usually picked by a window option can be scaled up or down as required by ZOOM command. This makes it possible to draw minute details accurately as well as to view the drawings in detail. In the case of large drawings parts of the drawing may be out of the screen. In order to view such hidden portion the PAN command is used. This command causes the drawing to be moved across the screen. These two are powerful commands which facilitate large drawings to be prepared accurately. REDRAW command is used to refresh the screen.

The drawing database is updated using REGENERATE command. The screen can be divided into 2, 3 or 4 parts to display different views of the same drawing using VIEWPORTS command. Working in windows environment also allows simultaneous displays and interactions in multiple overlapping windows. This means that the user gets multiple screens on one graphics screen. Windows can be shuffled by mouse click. It is possible to expand the contents of one window into another. There are commands to generate orthographic, isometric, perspective and axonometric projections. Dynamic viewing is also available in many packages.

## 6.11 CROSS HATCHING AND PATTERN FILLING

This is another important facility in drafting packages. All CAD softwares have this facility. The type of cross hatch line, the distance between lines and the angle of the filler lines can be chosen. Usually a chain of commands starting from "HATCH" leads to the choice. In some cases, instead of cross hatching with lines, a given pattern (available in a library of patterns) may also be chosen.

The choice of the area to be filled often may lead to difficulties. The best softwares simply need the information in terms of a point and all the area enclosing this point will be cross hatched or filled with patterns. All the connected area as long as it is not separated by any curve or line will be filled.

Hatching with text inside the hatch area is another facility that should be available. In such cases, the text may have to be first drawn, before "HATCH" command.

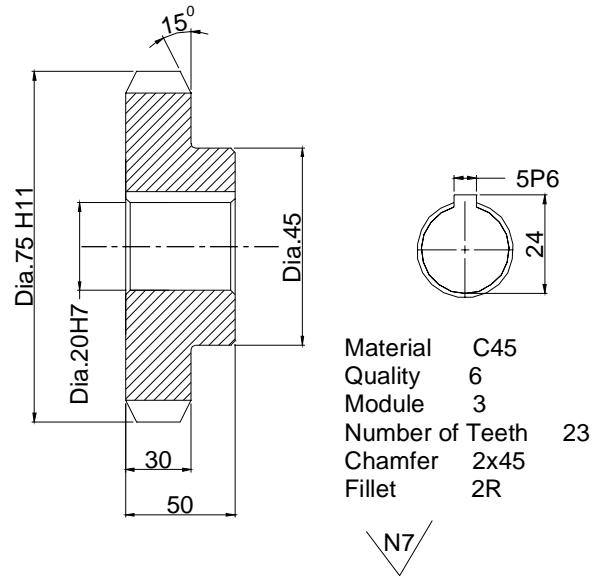
## 6.12 DIMENSIONING

Dimensioning and adding annotations are very important in any drawing. If the dimension of any object could be drawn just by pointing the object, it will be the best facility. Such a feature is known as automatic dimensioning, particularly if the dimensions are drawn in the various views of the object. The features of an object in the various views are not related at all and they are treated as separate objects, by the software and so dimensioning has to be done in the different views separately.

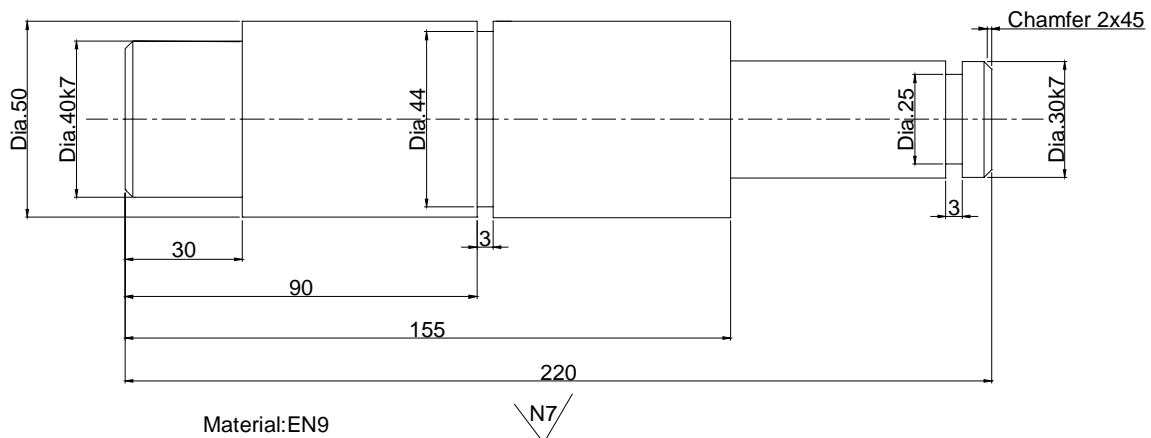
Generally linear dimensioning involves the drawing of two extension lines, (a dimension line with arrow heads) separated from the object. Additionally tolerance values may also have to be shown in some cases. It can thus be realized that dimensioning is rather a complex process and a lot of decisions are involved. Simple inexpensive 2-D softwares may not have an automatic dimensioning facility, but all of them should have the capacity to do these by separate instructions from the operator.

Choice should be available to draw the extension lines, in terms of location, length and the distance from the object. The location choice is generally by picking the end points of the object to be dimensioned. This is done interactively by some input device. The arrow size, the location of dimension text etc. are chosen by specifying a series of dimension variables. The position of the dimension line is also input by picking, whereas its angular location is indicated by instructions like horizontal, vertical, aligned etc. Choice is available to use the same base line to dimension a number of objects and also for continuous dimension writing along a line. Usually the actual length of the object is displayed by the computer but a different value can be chosen by the draftsman.

The dimensioning features also include angular, radial, diametrical, aligned and leader options. The associative dimensioning feature available in some software enables automatic change in the dimensioning when the entities are edited. Many CAD softwares permit generation of dimension styles compatible to ISO, ANSI, DIN and other standards. Dimensioning feature can be customized by assigning appropriate values for various dimension variables. Fig. 6.18 and 6.19 show two drawings created using 2-D drafting.



**Fig. 6.18 Drawing a Gear**



**Fig. 6.19 Drawing a Shaft**

### 6.13 ENQUIRY COMMANDS

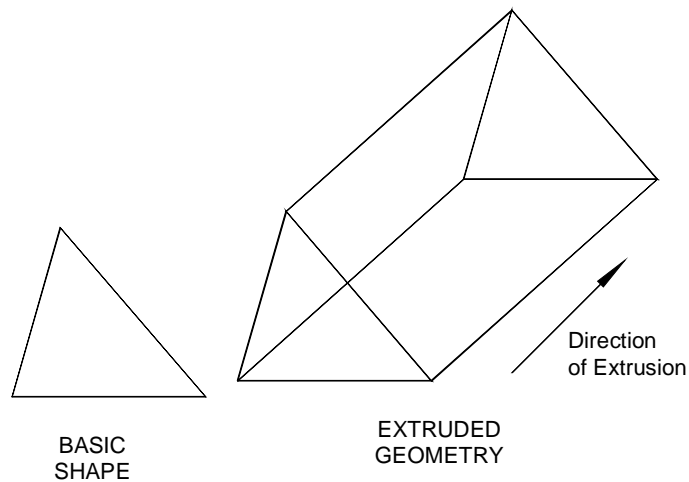
A modeling software may have commands to supply the user information on the coordinates of a point, distance between two points specified on the screen, the area and perimeter of a given plane figure, mass of a solid model, moments of inertia of a model etc. You can list the database of the drawing as well as list the details of any specific entity. Higher level packages can yield the complete mass properties.

## 6.14 3-D DRAWINGS

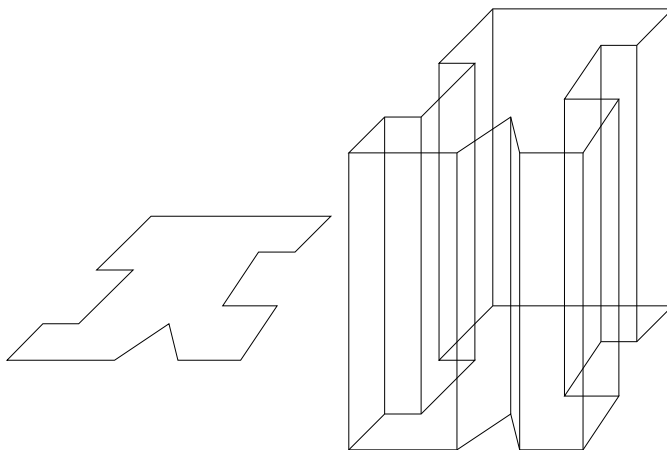
Though 2-D drafting can meet a substantial drafting requirements, 3-D modeling enables creation of objects in 3-D. 3-D drawings are prepared in several ways.

### 6.14.1 EXTRUSION (LINEAR SWEEP)

Simple 3-D objects can be created by extruding 2-D images in the third dimension. The extrusion thickness can be specified by an appropriate command. The objects extruded will have uniform thickness in the Z direction. Fig. 6.20 (a) shows a triangle extruded in the third dimension and Fig. 20 (b) shows the extrusion of a complex plane.



**Fig. 6.20 (a) Extrusion Example 1**

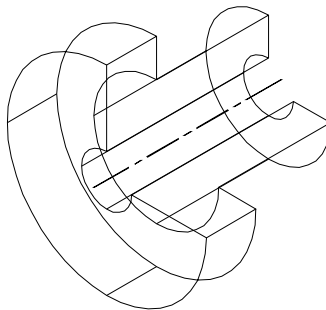


**Fig. 6.20 (b) Extrusion Example 2**

Another way of creating 3D views is by defining construction planes at different levels and drawing the sections of the object on these planes.

### 6.14.2 REVOLUTION

Wire frame images can be created by revolving an entity about an axis. In Fig. 6.21 a set of entities are revolved about an axis through  $270^\circ$  to create a wire frame object. Rotation through  $360^\circ$  will produce complete objects.

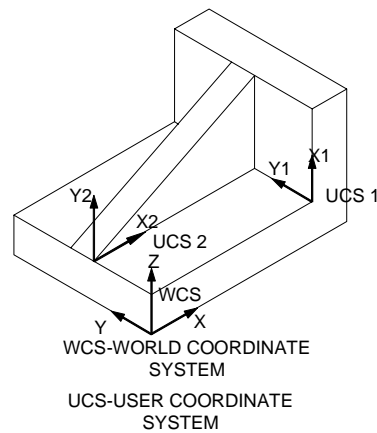


**Fig. 6.21 Revolution**

### 6.14.3 USING USER CO-ORDINATE SYSTEMS (UCS)

CAD packages have a facility to define several user co-ordinate systems. Plane figures can be drawn in these user co-ordinate systems to create a 3-D wire frame model. For example, consider the object shown in Fig. 6.22. Different sides of the object can be created in the respective planes as indicated.

A plane figure drawn in a User Co-ordinate System can be assigned a thickness to create a 3-D wire frame model. Complex 3-D models can be created using a combination of several user co-ordinate systems and thicknesses.



**Fig. 6.22 User Co-ordinate System**

### 6.15 PLOTTING A DRAWING

Plotters are output devices which produce hard copies of drawings with good resolution, as much as 2400×1200 dpi. The lines and curves so plotted appear neat and smooth as contrasted with the drawing shown on the VDU screen. (Plotters are available in various sizes (A4-A0) and they use single or multi colors. Printers are less accurate, but very useful particularly for commercial drawings like pie-charts.

Color printers can also be used to make hard copies of drawings. These devices should be configured to the system before use. All softwares provide driver programmes to drive these output devices. The flexibility of a software depends on the number of varieties of input/output devices for which it has driver programs available. Otherwise the choice of hardware is restricted. Many plotters are HP-GL (Hewlett Packard Graphics Language) compatible. Many plotters use fuzzy logic for vector sorting which reduces unnecessary movements while plotting. Laser plotters are also available now.

### 6.16 CONFIGURING THE DRAFTING SOFTWARE

A drafting package is a general purpose software which has to be run on several types of hardware environment. The task of modifying a package to make it suitable to work in a particular hardware environment is called configuring. The configuring is to be carried out for:

- i. Displaying the drawings on a particular type of monitor.
- ii. Interfacing a particular digitizer or mouse.
- iii. Interfacing a particular type of printer and/or a plotter.

This is carried out using device driver files provided by the software monitor.

### 6.17 CUSTOMISATION

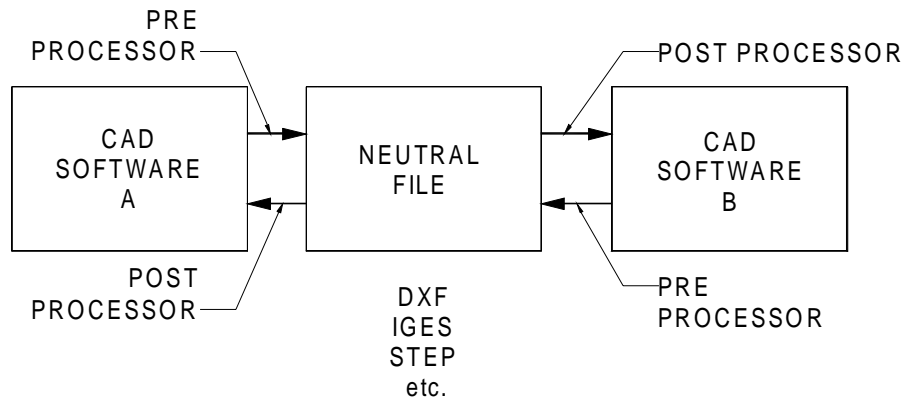
Drafting packages provide extensive customizable features. Many packages are provided with LISP based or "C" based programming environment. These can be used to develop utilities which can be put in menus and these will behave like any other command in the software. Apart from developing these programmes customization involves many other tasks which are listed below:

- i. Design of special menus - screen, pull down, icon, button etc.
- ii. Creating modifying line types.
- iii. Creating hatch patterns.
- iv. Creating symbols and fonts.
- v. Customizing help files.

- vi. Interface with text editors, database management programs, spread sheets, and communication programmes.
- vii. Use of command aliases for frequently used commands.

## 6.18 DRAWING INTERCHANGE FILES

It is necessary to export CAD data to other packages like analysis, CNC programming or other CAD packages. One way of doing it is using neutral files STEP, IGES or DXF files. Figure 6.23 shows how bi-directional data exchange between two CAD software packages using neutral files.



*Fig. 6.23 Drawing Data Exchange*

## 6.19 DRAWING OFFICE MANAGEMENT

CAD can increase the productivity in the drawing office considerably. Customization of the software and use of standard parts libraries created in-house or purchased from third part developers can cut down the time required to create drawings significantly. CAD packages also will help in improved drawing office management. Some of the relevant issues are briefly discussed below:

### 6.19.1 CREATION OF PARTS LIST

Part lists for an assembly can be organized and compiled in a desired format by extracting information from the drawings.

### 6.19.2 BILL OF MATERIALS (BOM)

BOM is an important document used by design, production, stores, inventory control, purchase, planning and costing departments. Creation of accurate bill of materials is one of the important steps in new product development. Suitable procedures can be devised to collect information required for the bill of materials from the CAD files of parts and this

information can be compiled using a database management software or a spread sheet to create the bill of materials. This requires the definition of appropriate attributes (Drawing No., Drawing Name, Material, No. off, Stock size, stock weight etc) in the drawing and extraction of this information from the drawing files. The BOM thus created will be more accurate as transcriptions are avoided.

### **6.19.3 SEARCHING FOR SIMILAR DESIGNS**

When a new design is to be created similar designs can be rapidly identified according to the classifications defined by the user. In this way duplication of design and drafting work can be avoided and standardization encouraged.

### **6.19.4 DESIGN CHANGES**

Parts list and title block information can be combined in the database with information such as order number and customer name. When a component is modified lists can be obtained of all customers who have ordered products that use the modified component.

### **6.19.5 REPLACING FAULTY COMPONENTS**

The discovery of a faulty component may affect a wide range of components in a company. All assemblies and subassemblies incorporating the component can be rapidly identified so that the time and effort required to replace it can be assessed.

### **6.19.6 PROJECT COSTING**

CAD helps to assess project costs by exporting CAD data to an estimating software to calculate the product costs accurately.

### **6.19.7 PRODUCT VARIATIONS**

Once a database of component drawings and assembly drawings are created, variations in the products can be easily made and design modifications, drawing retrieval etc. are made easier.

### **6.19.8 WEB ENABLED SOFTWARES**

Large engineering designs are carried out through collaborative engineering with design and development engineers located at geographically distributed design centres. It is therefore necessary to communicate the models of designs and Internet is a convenient tool for this. Modeling softwares provide facilities for import and export of CAD models through Internet. This facility is also useful for communication of product data between vendors and manufacturers as well as customers and manufacturers.

### **6.19.9. INTEGRATED DESIGN, DRAFTING AND DOCUMENTATION**

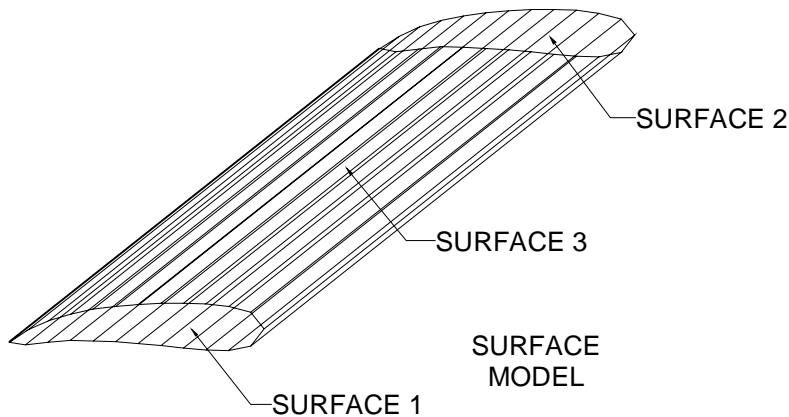
Design and drafting productivity can be further improved by integrating CAD process with spread sheets, equation solvers and word processing software. CAD packages can be



used to conceptualize designs. Data required for CAD can be accessed from spread sheets (like MS Excel, LOTUS 1-2-3etc) or database management software packages. Equation solvers can be used to process design rules and export the design data to modify CAD drawings. The CAD data can be exported to word processors to compile design documentation. The interactive data communication between linked geometry, spread sheet (or database), equation solvers and word processors helps to refine design concepts more rapidly and enables the designer to explore a wide variety of design options. Ultimately this exploration of possible designs will result in a better and more effective product.

## 6.20 SURFACE MODELING

All physical objects are 3-dimensional. In a number of cases, it is sufficient to describe the boundary of a solid object in order to specify its shape without ambiguity. This fact is illustrated in Fig. 6.24. The boundary is a collection of faces forming a closed surface. The space is divided into two parts by the boundary - one part containing the points that lie inside and forming the object and the other the environment in which the object is placed. The boundary of a solid object may consist of surfaces which are bounded by straight lines and curves, either singly or in combination.

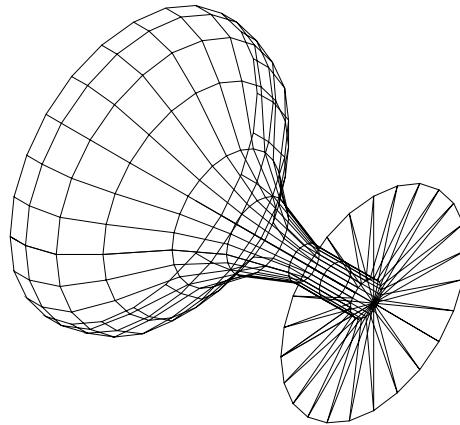


**Fig. 6.24 Representation of Boundary**

Figure 6.25 is typical of several components, one comes across in engineering. The surface of this component can be produced by revolving a profile about an axis of rotation.

A surface model is defined in terms of points, lines and faces. This type of modeling is superior to wire frame modeling discussed earlier in this chapter. A major advantage of surface modeling is its ability to differentiate flat and curved surfaces. In graphics, this helps to create shaded image of the product. In manufacture, surface model helps to generate

the NC tool path for complex shaped components that are encountered in aerospace structures, dies and moulds and automobile body panels.



**Fig. 6.25 A Typical Revolved Surface Model**

***A surface can be created in several ways:***

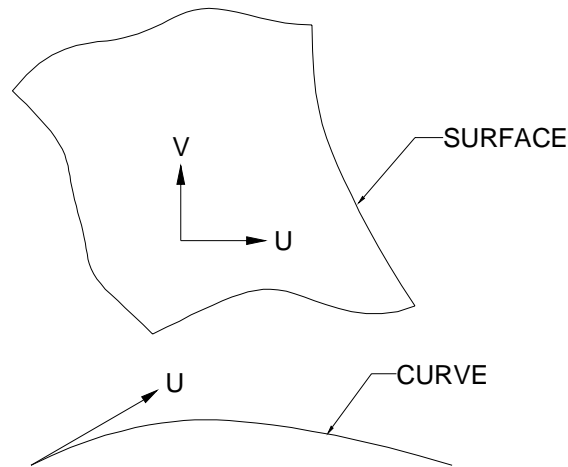
- i. Creating a plane surface by the linear sweep of a line or series of lines.
- ii. Revolving a straight line about an axis. Cylindrical, conical surfaces etc. can be generated by this technique.
- iii. Revolving a curve about an axis.
- iv. Combination of plane surfaces.
- v. Analytic surfaces: Planes, cylinders, cones, ellipsoid, parabolic hyperboloid etc can be defined by mathematical equations in terms of X, Y and Z co-ordinates.
- vi. Sculptured surfaces: These are also called free form surfaces. These are created by spline curves in one or both directions in a 3-D space. These surfaces are used in the manufacture of car body panels, aircraft structures, mixed flow impellers, telephone instruments, plastic containers and several consumer and engineering products.

Modeling of curves and surfaces is essential to describe objects that are encountered in several areas of mechanical engineering design. Curves and surfaces are the basic building blocks in the following designs:

- i. Body panels of passenger cars
- ii. Aircraft bulk heads and other fuselage structures, slats, flaps, wings etc.
- iii. Marine structures
- iv. Consumer products like plastic containers, telephones etc.

v. Engineering products like mixed flow impellers, foundry patterns etc

A curve has one degree of freedom while a surface has two degrees of freedom. This means that a point on a curve can be moved in only one independent direction while on surfaces it has two independent directions to move. This is shown in Fig. 6.26.



**Fig. 6.26 Degrees of Freedom**

## 6.21 REPRESENTATION OF CURVES AND SURFACES

A curve or a surface may be described or represented by a set of equations. These equations can be categorized into two forms:

### i. Generic form

The generic form in which any generic point  $(x, y, z)$  satisfies a relationship in implicit form in  $x, y,$  and  $z$  i.e.  $f(x, y, z) = 0$ . A single such constraint generally describes a surface while two constraints considered together can be thought of as a curve which is the intersection of two surfaces. This may be expressed in an explicit form in the following manner:

$$x = g^1(y, z)$$

$$y = g^2(x, z)$$

$$z = g^3(x, y)$$

### ii. Parametric form

A parametric curve is one whose defining equations are in terms of a simple, common independent variable known as parametric variable.

In the parametric form, the representation is done by a set of functions. A curve may be represented by

$$x = x(u)$$

$$y = y(u)$$

$$z = z(u)$$

where  $x$ ,  $y$ ,  $z$  are co-ordinates of the points on the curve which are functions of some parameter  $u$  and the parametric variable is constrained in the interval. For example, a point  $(x, y)$  is located at an angle  $\theta$  from  $+X$  axis on a circle with centre at  $(0, 0)$  and radius = 1 can be described in parametric form as:

$$x = \cos \theta$$

$$y = \sin \theta$$

where  $\theta$  is the parameter. Surfaces are described similarly for which  $x$ ,  $y$  and  $z$  are functions two independent parameters  $u$  and  $v$ . Parametric design is very popular in computer aided design for a variety of reasons, which are listed below:

- Separation of variables
- Each variable is treated alike
- More degrees of freedom/control
- Parametric equations can be transformed directly
- Infinite slopes can be handled without computational breakdown
- Easy to express as vectors
- Amenable to plotting and digitizing
- Inherently bounded

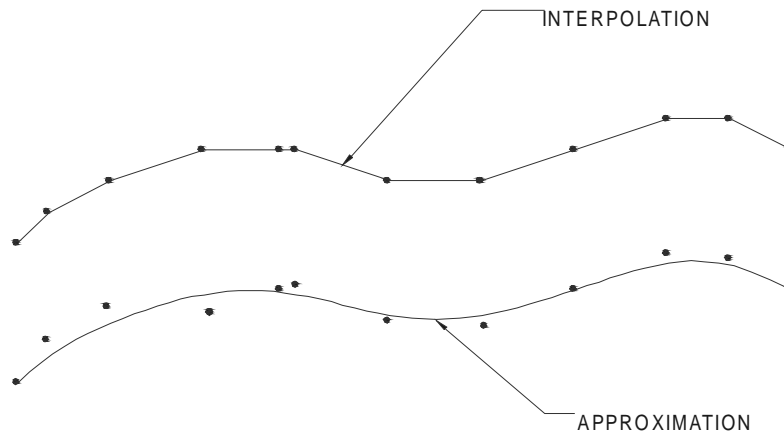
## 6.22 DESIGN OF CURVED SHAPES

Design of curved shapes should satisfy the following requirements:

- i. It should be possible to represent the shape mathematically.
- ii. The modeling should involve minimum computation.
- iii. It should be possible to generate a CNC program to machine the surfaces (2, 3, 4 and 5 axis machining) or to prepare a mould or die to make the part (as in plastic injection molding or casting or automobile panel pressing).

A component can be designed using the curves and shapes which can be mathematically described e.g. arc, circle, conics, ellipsoid, hyperbolic paraboloid, sphere, and cone, cylinder, linear, conical - and circular swept surfaces etc. However very often the designer starts with specifying a few points which roughly describe the shape.

Two approaches are available to designers to model curves and surfaces in such cases: interpolation and approximation. The interpolation essentially tries to pass a curve on a surface called interpolant through all these points. Approximation tries to fit a smoother curve on surface which may be close to these points but may not actually pass through each of them. Fig. 6.27 illustrates the difference between interpolation (a) and approximation (b).



**Fig. 6.27 Interpolation and Approximation**

One of the popular methods of interpolation is to use the Lagrange polynomial, which is the unique polynomial of degree  $n$  passing through  $n + 1$  points. However, Lagrange polynomial is unsuitable in modeling of curves because of:

- i. Large number of computations involved and
- ii. Tendency for the curve to oscillate between data points when the data points are large.

Another approach is to look for a polynomial of fewer degrees than  $W$  passing through these  $W + 1$  data points. This is done by combining polynomials of lesser degree passing through several consecutive data points and smoothly piecing several such curve segments together by blending. In general, the modeling of curves is done to satisfy the following:

- i. Axis independence
- ii. Global and local control
- iii. Smoothness of curves
- iv. Versatility
- v. Continuity between adjoining segments of curve.

### 6.23 CUBIC SPLINES

Splines are functions that are used for fitting a curve through a number of data points. A cubic spline has the property that the three co-ordinate functions  $x(u)$ ,  $y(u)$ , and  $z(u)$  are each cubic polynomials in the variable  $u$ :

$$x(u) = a u^3 + b u^2 + c u + d$$

$$y(u) = e u^3 + f u^2 + g u + h$$

$$z(u) = j u^3 + k u^2 + l u + m$$

Whereas parametric curves are generally considered to be defined over an infinite range of parameter values of  $u$ , it is always necessary to limit these to a finite interval when modeling shapes on a computer. The domain  $u$  is, therefore taken as  $0 < u \leq 1$  in the discussion that follows:

A spline passes through two end points and satisfies differentiability condition at these end points. These four conditions require a polynomial degree of at least 3. The derivations of cubic splines for  $x$ ,  $y$  and  $z$  are similar. The difference will be only in the end point coordinates and derivatives at the end points. Therefore only the derivation of  $x(u)$  is considered here.

Let  $x(0)$ ,  $x(1)$ ,  $x'(0)$  and  $x'(1)$  are the end points and the derivatives at the end points respectively.

$$\begin{aligned} \text{Since } x(u) &= au^3 + bu^2 + cu + d, \text{ we get} \\ x(0) &= d \\ x(1) &= a + b + c + d \\ x'(0) &= c \\ x'(1) &= 3a + 2b + c \end{aligned}$$

The above equations can be solved to obtain the four equations given below:

$$\begin{aligned} a &= 2X(0) - 2X(1) + X'(0) + X'(1) \\ b &= -3X(0) + 3X(1) - 2X'(0) - X'(1) \\ c &= X'(0) \\ d &= X(0) \end{aligned}$$

(or)

$$\begin{bmatrix} a \\ b \\ c \\ d \end{bmatrix} = \begin{bmatrix} 2 & -2 & 1 & -1 \\ -3 & 3 & -2 & -1 \\ 0 & 0 & 1 & 0 \\ 1 & 0 & 0 & 0 \end{bmatrix} \begin{bmatrix} x(0) \\ x(1) \\ x'(0) \\ x'(1) \end{bmatrix}$$

The coefficients of cubic spline polynomials  $y(u)$  and  $z(u)$  are similarly obtained by replacing  $x$  data by  $y$  and  $z$  data.

In a vectorial form the parametric cubic curve can be expressed as:

$$P(u) = au^3 + bu^2 + cu + d$$

where  $u \in (0,1)$

$$P(u) = [u^3 \ u^2 \ u \ 1] [a \ b \ c \ d]^T$$

$$\text{Let } U = [u^3 \ u^2 \ u \ 1] \text{ and } A = [a \ b \ c \ d]^T$$

$$P = UA$$

Curves are defined by interpolating points and tangents at these points. The parametric cubic curve can be designed using the four vectors  $P(0)$ ,  $P(1)$ ,  $P'(0)$  and  $P'(1)$ . Each one of these vectors has three components.

$$P_0 = d$$

$$P_1 = a + b + c + d$$

$$P'(0) = c$$

$$P'(1) = 3a + 2b + c$$

$$P = (2u^3 - 3u^2 + 1)P_0 + (-2u^3 + 3u^2)P_1 + (u^3 - 2u^2 + u)P'_0 + (u^3 - u^2)P'_1$$

$$\text{Let } F_1 = 2u^3 - 3u^2 + 1$$

$$F_2 = -2u^3 + 3u^2$$

$$F_3 = u^3 - 2u^2 + u$$

$$F_4 = u^3 - u^2$$

$$\text{then } P = F_1 P_0 + F_2 P_1 + F_3 P'_0 + F_4 P'_1$$

$$\text{Let } F = [F_1 \ F_2 \ F_3 \ F_4] \text{ and } B = [P_0 \ P_1 \ P'_0 \ P'_1]$$

$$\text{then } P = F B$$

$F_1, F_2, F_3, F_4$ , are called blending function or Hermite polynomial basis functions.  $B$  is the matrix of geometric coefficients.  $F$  is the blending function matrix. The blending function matrix  $F$  can be written as the product of two matrices.

$$F = U M$$

Where

$$M = \begin{bmatrix} 2 & -2 & 1 & 1 \\ -3 & 3 & -2 & -1 \\ 0 & 0 & 1 & 0 \\ 1 & 0 & 0 & 0 \end{bmatrix}$$

where  $M$  is called universal transformation matrix.

$$\text{Therefore } P = U M B$$

$$P = U A$$

$$\text{Hence } A = M B$$

and conversely

$$B = M^{-1} A$$

where

$$M^{-1} = \begin{bmatrix} 0 & 0 & 0 & 1 \\ 1 & 1 & 1 & 1 \\ 0 & 0 & 1 & 0 \\ 3 & 2 & 1 & 0 \end{bmatrix}$$

For a given set of end points  $P_0$  and  $P_1$  and slopes  $P'_0$  and  $P'_1$  several sets of curves can be generated by varying the magnitude of the tangent vectors. (unit tangent vector  $t = Pu / |Pu|$ ).

Figure 6.28 shows a cubic spline connecting four points. There are several other formulations of cubic splines. Ferguson used cubic polynomials for curve and surface design in aircrafts. However, these methods generally suffer from the fact that they do not allow the user to change the smoothness of the curve.

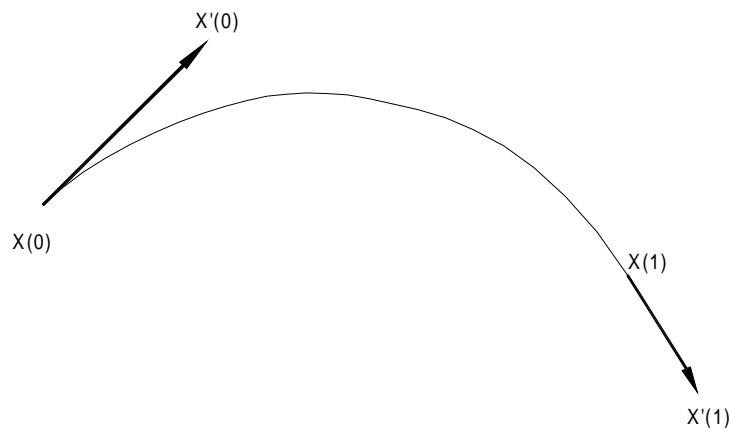


Fig. 6.28 Cubic Spline

## 6.24 BEZIER CURVES

Bezier curves, developed by P. Bezier at Renault Automobile Company and P. de Casteljau at Citroen, France are used for curve and surface design of automobile panels. A Bezier curve is blended at the joints and is completely defined by four consecutive points  $(X_0, Y_0)$ ,  $(X_1, Y_1)$ ,  $(X_2, Y_2)$ ,  $(X_3, Y_3)$ . The curve passes only through the first and fourth point. The two intermediate points are used to define the slope of the curve at the end points. If  $X_0, X_1, X_2$  and  $X_3$  are the X- co-ordinates of the control points, it is assumed that :

- i. The curve passes through the end points  $X_0$  and  $X_3$
- ii. The slope at the points are:
 
$$X'(0) = 3(X_1 - X_0)$$



$$X'(1) = 3(X_3 - X_2)$$

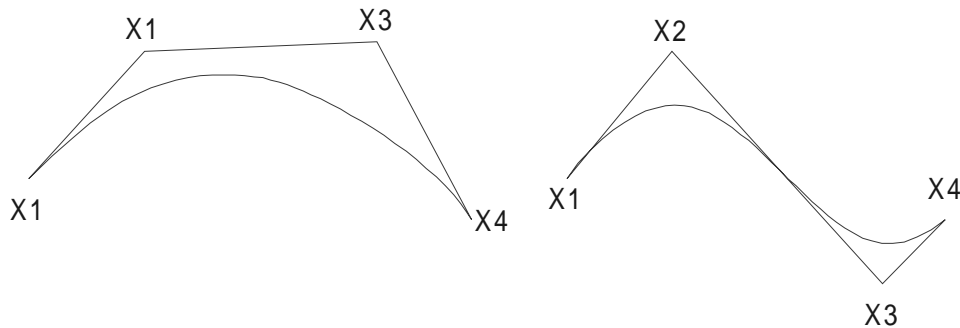
Using these properties, the coefficients of Bezier curve for x term can be expressed as :

$$\begin{bmatrix} a \\ b \\ c \\ d \end{bmatrix} = \begin{bmatrix} -1 & 3 & -3 & 1 \\ 3 & -6 & 3 & 0 \\ -3 & 3 & 0 & 0 \\ 1 & 0 & 0 & 0 \end{bmatrix} \begin{bmatrix} X_0 \\ X_1 \\ X_2 \\ X_3 \end{bmatrix}$$

The cubic polynomial  $x(t)$  in the Bezier form can be expressed as :

$$x(t) = \begin{pmatrix} u^3 & u^2 & u^1 & 1 \end{pmatrix} \begin{bmatrix} -1 & 3 & -3 & 1 \\ 3 & -6 & 3 & 0 \\ -3 & 3 & 0 & 0 \\ 1 & 0 & 0 & 0 \end{bmatrix} \begin{bmatrix} X_0 \\ X_1 \\ X_2 \\ X_3 \end{bmatrix}$$

The advantages of Bezier curve over cubic spline is that the direction of the curve at the joints can be defined and changed simply by specifying the position of the second and third data points. Changing a control point not only affects the shape of the curve near the control point but has an influence throughout the curve. This lack of local control is a major weakness of Bezier curve. Fig. 6.29 shows Bezier cubic segments for two sets of values of  $X$ .



**Fig. 6.29 Bezier Curve**

The Bezier cubic segment discussed above is a special case of the more general Bezier polynomial curve segment

$$P(u) = \sum_{i=0}^3 P_i B_{i,3}(u)$$

where  $u \in [0,1]$

With blending functions:  $B_{i,n}(u) = C_{(n,i)} u^i (1-u)^{n-i}$

where  $n$  is the binomial coefficient

$$C(n, i) = \frac{n!}{i!(n-i)!}$$

and  $p(u)$  are the control points and there are  $n+1$  of them defining the vertices of the characteristic polygon.

### 6.25 $\beta$ -SPLINES

This form of cubic segments uses a third set of basis functions different from the types discussed earlier. A cubic  $\beta$ -spline curve is a special case of spline curve. The equation for this curve can be written as:

$$P(u) = \sum_{i=1}^n P_i N_{i,k}(u) \\ u \in [0, (n-k+2)]$$

This generates what is known as piecewise polynomial. The  $N(u)$  blending functions are defined recursively as :

$$N(u) = 1 \text{ if } t_i < u < t_{i+1} \\ = 0 \text{ otherwise}$$

$$N(u) = \frac{(u-t)N_{i,k}(u)}{t_{i+1}-t_i} + \frac{(t_{i+1}-u)N_{i+1,k}(u)}{t_{i+1}-t_i}$$

The resulting parametric polynomials are of degree  $(k-1)$ . The  $t$  are called knot values. For an open curve there are

$$t_i = 0 \quad \text{if } i < k \\ t_i = i - k + 1 \quad \text{if } k \leq i \leq n \quad i \in [0, n+k] \\ t_i = n - k + 2 \quad \text{if } i > n$$

The blending functions confine the effects of a control point movement to the immediate locale. Thus the curve change shape is local and not global as it is for Bezier curves.

$$x(u) = (1 \ u \ u^2 \ u^3) 1/6 \begin{bmatrix} 1 & 4 & 1 & 0 \\ -3 & 0 & 3 & 0 \\ 3 & -6 & 3 & 0 \\ -1 & 3 & -3 & 1 \end{bmatrix} \begin{bmatrix} x_{i-2} \\ x_{i-1} \\ x_i \\ x_{i+1} \end{bmatrix}$$

When the control points are distinct, this curve is continuous in slope and in curvature between successive segments but it does not pass through any of the intermediate control points. The cubic  $\beta$ -spline has the advantage that the control points may be moved without affecting slope and curvature continuity and only four spans of the overall curve will be affected by the change. Moreover, by allowing two control points to coincide it is possible to create a curvature discontinuity. A slope discontinuity, similarly, can be introduced by choosing three successive control points to be coincident.

It is possible to represent complex curve shapes by considering composite curves constructed from individual segments, in the case of cubic spline, Bezier and B-spline techniques.

## 6.26 NURBS AND $\beta$ -SPLINES

Two important surface representation schemes exist that extend the control of shape beyond movement of control vertices. These are NURBS (Non Uniform Rational  $\beta$ -Splines) and  $\beta$ -splines. In the case of NURBS a local vertex is extended to a four dimensional co-ordinate, the extra parameter being a weight that allows a subtle form of control which is different in effect to moving a control vertex. In the simplest form of  $\beta$ -spline control two global parameters (bias and tension) are introduced which affect the whole curve.

### 6.26.1 NURBS

A non-uniform  $\beta$ -spline curve is defined on a knot vector where the interior knot spans are not equal. A rational  $\beta$ -spline is defined by a set of four dimensional control points.

$$P = (W_i X_i, W_i Y_i, W_i Z_i, W_i)$$

The perspective map of such a curve in three dimensional space is called a rational  $\beta$ -spline curve.

$$\begin{aligned} P(u) &= H \left[ \sum_{i=0}^n P_i N_{i,k}(u) \right] \\ P(u) &= H \left[ \sum_{i=0}^n P_i^W N_{i,K}(u) \right] \\ &= \frac{\sum_{i=0}^n P_i W_{i,K}(u)}{\sum_{i=0}^n W_{i,K}(u)} \\ &= \sum_{i=0}^n P_i R_{i,K}(u) \end{aligned}$$

Rational  $\beta$ -splines have the same analytical and geometric properties as non-rational  $\beta$ -splines.

$W_i$  associated with each control point is called a weight and can be viewed as an extra shape parameter.  $W_i$  affects the curve only locally and can be interpreted geometrically as a coupling factor. The curve is pulled towards a control point if  $W$  increases.

### 6.26.2 $\beta$ - SPLINES

$\beta$ - splines are obtained from  $\beta$ -splines by introducing two new degrees of freedom: bias and tension. These can be applied uniformly or non-uniformly.

## 6.27 REPRESENTATION OF SURFACES

A surface can be defined as the locus of points which satisfy a constraint equation in the form of  $F(X, Y, Z) = 0$ . In parametric form a surface may be represented as

$$\begin{aligned}x &= X(u, v) \\y &= Y(u, v) \\z &= Z(u, v)\end{aligned}$$

where  $X$ ,  $Y$  and  $Z$  are suitable functions of two parameters  $u$  and  $v$ . For example, the parametric representation of the surface of a sphere whose centre is at the origin of coordinates and of radius  $R$  is

$$\begin{aligned}x &= X(\theta, \phi) &= R \sin \phi \cos \theta \\y &= Y(\theta, \phi) &= R \sin \phi \sin \theta \\z &= Z(\theta, \phi) &= R \cos \phi\end{aligned}$$

## 6.28 DESIGN OF SURFACES

The design of surfaces may be based on quadrics like ellipsoid, hyperboloid, cone, hyperbolic cylinder, parabolic cylinder, elliptic cylinder and elliptic paraboloid. A surface may be generated by sweeping a pattern curve along a spline curve. The swept surface may also be linear, conical linear or circular swept surface.

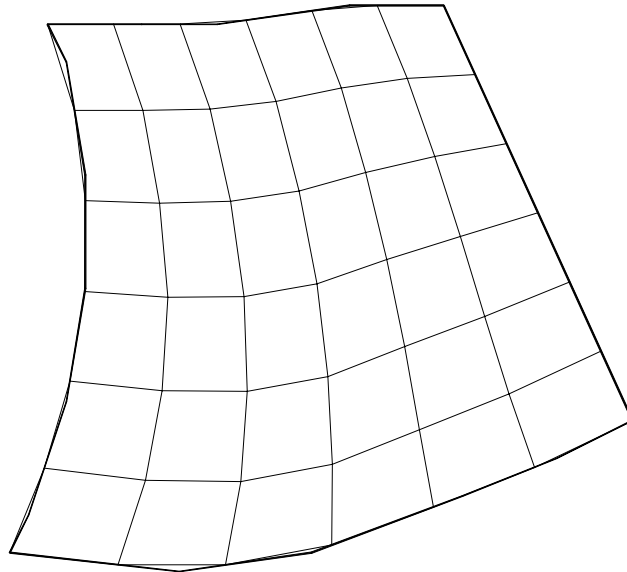
## 6.29 PARAMETRIC DESIGN OF SURFACES

Parametric surfaces may be defined in one of the following methods:

- i. In terms of points of data (positions, tangents, normals)
- ii. In terms of data on a number of space curves lying in these surfaces.

The resulting surface will either interpolate or approximate the data. Surfaces are normally designed in patches, each patch corresponding to a rectangular domain in  $u$ - $v$  space. A surface patch defined in terms of point data will usually be based on a rectangular

array of data points which may be regarded as defining a series of curves in one parameter direction which in turn are interpolated or approximated in the direction of the other parameter to generate the surface. Fig. 6.30 shows the parameter curves on a surface patch defined by a rectangular array of data points.



**Fig. 6.30 A Surface Patch**

### 6.30 BICUBIC POLYNOMIAL SURFACE PATCHES

A bicubic polynomial surface can be represented in the form:

$$r = \begin{bmatrix} 1 & u & u^2 & u^3 \end{bmatrix} \begin{bmatrix} a_{11} & a_{12} & a_{13} & a_{14} \\ a_{21} & a_{22} & a_{23} & a_{24} \\ a_{31} & a_{32} & a_{33} & a_{34} \\ a_{41} & a_{42} & a_{43} & a_{44} \end{bmatrix} \begin{bmatrix} v \\ v^2 \\ v^3 \end{bmatrix}$$

where  $a_{ij}$  ( $i, j = 0, 1, 2, 3$ ) is the  $4 \times 4$  matrix of vector coefficients.

A general representation of bicubic surface patch is:

$$r = R(u, v) = U M A M^T V$$

Where M is the basis matrix

$$U = [1 \ u \ u^2 \ u^3]$$

$$A = a_{ij}$$

$$V = [1 \ v \ v_2 \ v_3]$$

For Coon's patch, the basis function  $M$  is identical to that of cubic spline segment.

$$M = \begin{bmatrix} 1 & 0 & 0 & 0 \\ 0 & 1 & 0 & 0 \\ -3 & 3 & -2 & -1 \\ 2 & -2 & 1 & 1 \end{bmatrix}$$

The vector coefficients for Coon's patches are given by

$$A = \begin{bmatrix} R(0,0) & R(0,1) & R(0,0) & R(0,1) \\ R(1,0) & R(1,1) & R(1,0) & R(1,1) \\ R(0,0) & R(0,1) & R(0,0) & R(0,1) \\ R(1,0) & R(1,1) & R(1,1) & R(1,1) \end{bmatrix}$$

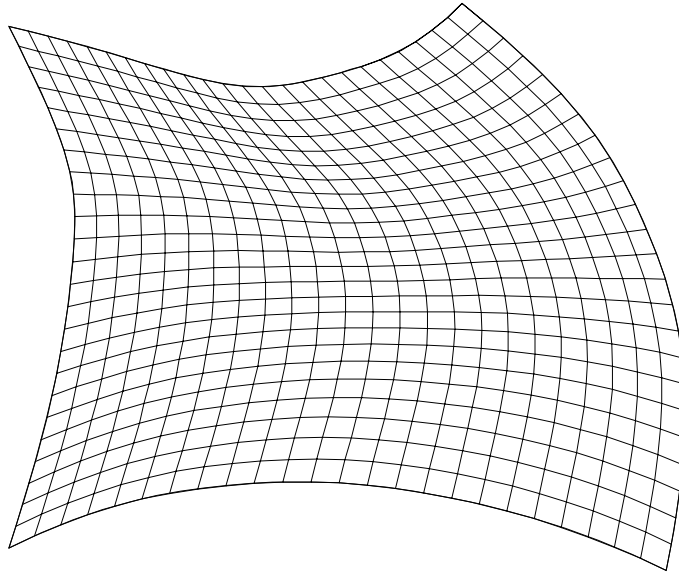
The position and derivative data on two adjacent corners effectively define not only the edge curve which joins them but also the cross slope at each point on the edge. This makes it possible to combine two or more patches with continuity of position and slope.

### 6.31 BEZIER BICUBIC SURFACE PATCHES

The Bezier bicubic surface patch uses the basis matrix:

$$M = \begin{bmatrix} 1 & 0 & 0 & 0 \\ -3 & 3 & 0 & 0 \\ -3 & 6 & 3 & 0 \\ -1 & 3 & -1 & 1 \end{bmatrix}$$

The vector coefficients are given by a  $4 \times 4$  matrix of position vectors for sixteen points forming a characteristic polyhedron. Fig. 6.31 shows the characteristic polyhedron for a Bezier surface. The four corner points  $R(0,0)$ ,  $R(3,0)$ ,  $R(3,3)$  and  $R(0,3)$  lie at the corners of the surface patch itself whereas remaining points do not lie on the patch. The four points along each edge of the polyhedron define the four edge curves of the patch. The four interior points determine the cross derivatives at the corner and cross slopes along the nearest edges to them.



**Fig. 6.31 Bi-cubic Surface Patch**

### 6.32 CUBIC B-SPLINE SURFACES

The basis function for a cubic B-spline surface is the same as that of cubic B-spline curve.

As in the case of B-spline curve, none of the control points forming the characteristic polyhedron lies on the surface.

Composite surfaces can be obtained by combining several surface patches. Table 6.1 gives the properties of the surfaces generated by the common methods.

**Table 6.1 Properties of Surfaces Created by Different Methods**

<i>Method</i>	<i>Property</i>
Coon's patch	Slope and position continuity
Bezier Bicubic patch	Position continuity
Uniform B-spline	Second order continuity

The surfaces patches described above cover a rectangular domain in  $u$ - $v$  space. There are also methods proposed for interpolation on triangular and pentagonal domains.

### 6.33 SURFACE MODELING IN COMMERCIAL DRAFTING AND MODELING SOFTWARE

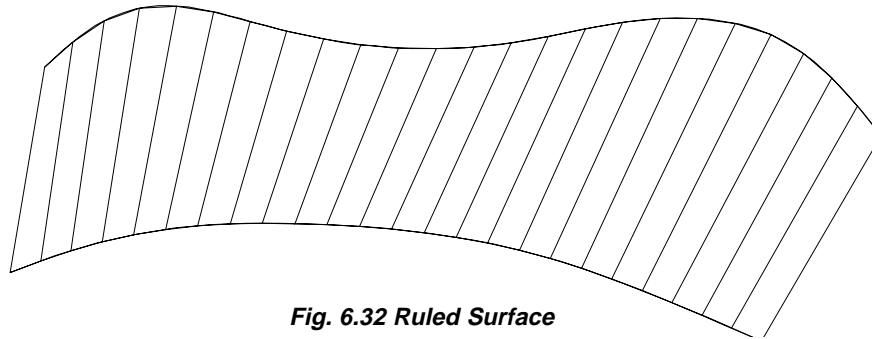
Surface types available for geometric modeling range from simple planes to complex sculptured surfaces. These surfaces are usually represented on the workstation terminals

as a set of ruled lines. However, computer recognizes these lines as continuous surfaces. Users select surface types from a menu to model individual details or fully envelope parts. Some of the features of surface modeling packages are given below:

### 6.33.1 SURFACE MODELING COMMANDS

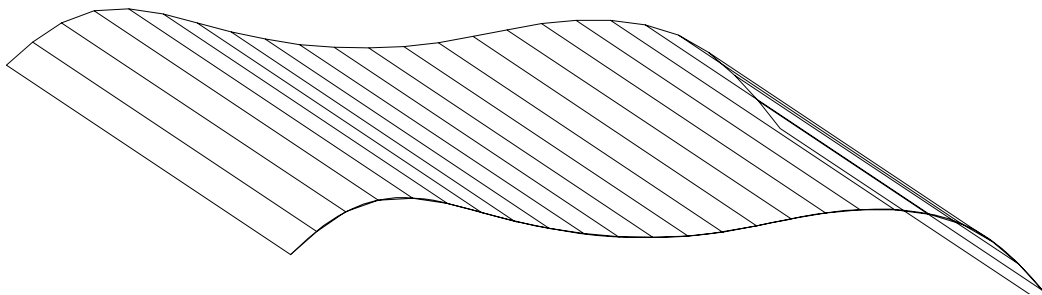
There are a number of commands to create a surface model

- i. 3-D face: The different faces of an object can be modeled using this command. The X,Y,Z co-ordinates of each vertex are input one after another to model a face and each of the faces is defined one after another in this manner.
- ii. P face: The P-face command produces a general polygon mesh of a arbitrary topology. Using this command, it is possible to avoid defining a single vertex several times as is done in 3-D face command. The user defines all vertices and then defines the faces in terms of the vertices.
- iii. Rulesurf: This command creates a polygon representing the ruled surface between two curves. Figure 6.32 shows an example of ruled surfaces.



**Fig. 6.32 Ruled Surface**

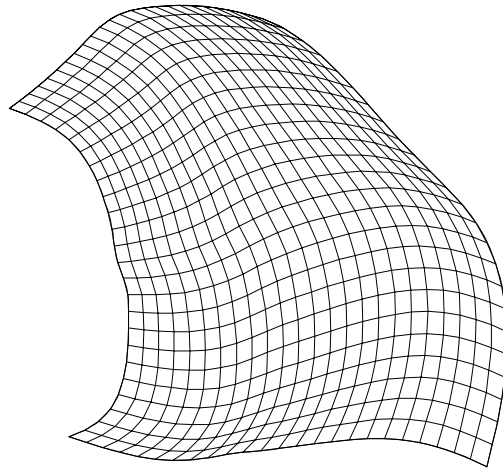
- iv. Tabsurf: A polygon mesh representing general tabulated mesh defined by a path curve and a direction vector (generatrix) is created by this command. Fig. 6.33 shows a typical surface created by this command.



**Fig. 6.33 Examples of Tabulated Surface**



- v. **Revsurf:** A surface of revolution is created by rotating a path curve or profile about an axis. The rotation can be through 360 degrees or part of it.
- vi. **Edgesurf:** This command constructs a Coon's surface patch using four adjoining curved edges, an example of edgesurf commands is shown in Fig. 6.34.



**Fig. 6.34 Example of Edge Surface**

### **6.33.2 SURFACE MODELING FACILITIES AVAILABLE IN AN ADVANCED MODELER**

An advanced surface modeler helps to design complex sculptured surfaces easily. They provide a number of tools for model creation, shape control and visualization.

- i. **Model creation features for curves and surfaces:**
  - Accurate fitting of unevenly spaced points
  - Control over tangency, curvature and inflection
  - Capability of one surface on to another
  - Projection of one surface on to another
  - Offset curves
  - Planar and ruled surfaces
  - Surfaces of revolution
  - Lofting
  - Sweeping
  - Blending
  - Surface created from 3-D digitized points
  - Interpolation of surfaces
  - Offset surfaces
  - Split and merging of surfaces

**ii. Shape control of surfaces:**

Advanced surface modeling softwares make it easy to effect changes in design and shape. They provide what is called variational constraint based shape control. Shape control can be effected through dimensional or geometric constraints and can have tangent associativity. Surface can also be controlled by equations. Advanced energy based shape control helps to:

- fair curves
- achieve higher order edge/tangency control
- introduce local bulges or inflections
- shape curves locally to fit a specific point

**iii. Visualization:**

Surface models have visualization tools for shading, hidden line elimination, creation of perspective views and evaluated surface displays.

**6.33.3 SOLID MODEL BASED ASSEMBLY DESIGN**

Once components are created as solid models, assembly software enables the designer to create a complete software mock up of the product. Assembly software is an interactive tool for creating and manipulating large mechanical assemblies. This software helps to position a part relative to the other using intuitive positing and mating relationships which define the design intent. Design changes to any part navigate through the entire assembly, dynamically updating part and subassembly positions. Positioning relationships include face-to-face and edge-to-edge commands making it easy to specify mating, alignment, and offset, and insertion, parallel and angular relationships among parts.

A top down approach is used in assembly design. The design leader can layout and plan assembly and create a product structure for the entire team. The product structure is associative to assembly geometry and remains accessible to the project team. Outline geometry and spatial envelopes to a subassembly or part can be defined and included in the hierarchy.

As and when the design team details designs of parts these designs are included in the assembly in the place of spatial envelopes. The design gradually grows in complexity while maintaining the spatial constraints defined earlier. Throughout the design process, multiple users can access the assembly design. The design and data management capabilities of the assembly software provides a design check out and referencing system for multiple users. Changes can be communicated not only to members of the design team but also to other product assemblies which use them.

Assembly design software provides other facilities too. The designer can track part numbers, part names, revisions and versions easily. In fact, versions can be assigned automatically as design changes. In order to create Bill of Materials (BOM), BOM attributes can be added to part or assembly. When parts are revised, the assemblies which use these parts are modified automatically. When assembly or parts within assembly change associated drawings created by the drafting software are automatically updated.

Assembly design software is a powerful tool for design evaluation. Since parts are designed in solid models the design can carry out checks for interference between mating parts and subassemblies. It is also possible to animate kinematic assemblies to evaluate how mechanisms work. Since variational geometry is used, the designer can vary the dimensions of the links to study the impact of design changes and articulate the mechanism in real time.

Assembly level mass and inertial properties can also be calculated. The rendering capabilities available in the modeling package enable true to life presentation of the assembly to management, marketing, manufacturing, purchase and other downstream users for review. Their feedback will be useful to avoid costly design changes at the end of product development cycle.

#### **6.33.4 SOLID MODEL BASED DRAFTING**

The drafting process creates production drawings. When solid model based design is followed, the production drawings can be generated from the solid model itself. Some drafting systems allow either a single user or dual user. In the single user mode, the entire design/drafting job is done by a single designer by creating a design with solid or assembly modeler and documenting that model using the drafting module. Bi-directional associativity helps to make changes to the solid model by incorporating a change in the detail drawing. The dual user approach is suitable for organizations where design and drafting tasks are carried out by separate persons. This mode of work enables the draftsman to begin his work even before the designer completes his design. Concurrent associativity allows the drawing to be updated while maintaining design change control with the design engineer. Drafting module provides the following additional facilities also:

- (i) Set up and create associative single or multiple cross sections through parts with automatic cross hatching
- (ii) Associative detail views can be added
- (iii) Make first angle or third angle projections, isometric, auxiliary or true projections
- (iv) Multiple view of one or more drawings can be placed on one drawing or multiple drawings
- (v) Automatic removal or display of hidden line by dashed lines
- (vi) Border, title block or the necessary drawing format can be added
- (vii) Different layers for different parts of the drawing can be specified.

Many solid modeling packages provide exhaustive symbol libraries or facilities to create symbols which expedite detailing of drawings. A variety of dimensioning techniques are available. Dimensioning can be automatic or a dynamic navigation style with user interaction can be adopted. In the latter, as the draftsman traverses the drawing, the geometry entities are highlighted. Appropriate icons are displayed next to the cursor that represent the dimensions. These dimensions can be added simply by picking with the cursor. Dimensioning supports ANSI, ISO, DIN, BIS and JIS. Geometric dimensioning and

tolerancing methods are also available in the package. Provision for adding text or annotations in different languages is also available. Another facility available is the associative cross hatching facility with ability to recognize internal holes and islands.

Another feature of a drafting module is the dynamic Bill of Materials that automatically updates when changes are made to the drawing. This ensures that BOM accurately reflects the data of the drawing.

In addition to the above the drafting module includes integrated drawing management capabilities. Some of these capabilities are listed below:

- (i) Lists the solid model associated with the part drawing
- (ii) Lists all drawings associated with a model
- (iii) Searches for a drawing by name, number or the draftsman
- (iv) Stores the drawings in libraries
- (v) Retrieve drawings
- (vi) Tracks drawing stage (in-design, check, released etc)
- (vii) Tracks revisions and versions
- (viii) Compiles total time spent on a drawing
- (ix) Tracks drawings read from STEP, IGES and DXF files
- (x) Creates of engineering change order
- (xi) Provides project configurations

Drafting modules associated with solid modeling packages can also be used for stand alone drafting. The features of a drafting package are discussed in a subsequent section in this chapter.

### 6.33.5 SOLID MODEL BASED MECHANISM DESIGN

Solid model based kinematic analysis can be used to determine complex motions of mechanisms. A mechanical design software is used for this purpose. Mechanism models are defined directly on the assembly model geometry. Rigid models are defined directly on the assembly model geometry. Rigid bodies are automatically understood and joints and constraints are defined simply by selecting appropriate locations on the assembly. Motions of mechanisms and loads are defined using a forms based user interface and can be defined by mathematical expressions or sketches. All solid geometry and inertia properties can be accessed from the assembly design. Mechanism design capabilities include the following :

#### ***Joint definition***

- Revolve
- Universal
- Planar

General (screw, rack & pinion)

Ball

Translational

Cylindrical

### **Constraints**

Ground

Spring/damper

Coupler

Gears

### **Motions**

Rotational about revolute or cylindrical joint

Translation along a cylindrical or translational joint

### **Loads**

Rotational and translational forces

Gravity

Torque

Velocity

Acceleration

### **Functions**

Ability to display several simultaneous functions

Functions defined by mathematical expressions

Transformations to manipulate functions

Geometry checking to determine the validity of mechanisms

Once joints, constraints and functions have been defined the mechanism can be solved using an internal solver. Some of the capabilities of a typical mechanism solver are given below:

- (i) Analysis of open and closed loop mechanisms
- (ii) Shaded animation
- (iii) Determination of position, velocity and acceleration of all bodies
- (iv) Automatic solid model based interference checking
- (v) Joint, inertia and spring forces are automatically calculated
- (vi) Relative position, velocity and acceleration between any two arbitrary points can be obtained
- (vii) Plotting facilities are available

This kinematic analysis module as an add on to solid modeling packages also will have facility to preprocess data to be used in an advanced kinematic analysis package like ADAMS or DADS.

#### 6.33.6 FINITE ELEMENT MODELING FROM SOLID MODELS

Optimization of designs require detailed analysis to determine stresses, deflection, natural frequencies, mode shapes, temperature distribution, heat flow rates etc. Finite element technique is used to carry out these analysis is to create a finite element model. The solid model geometry can be used directly to create the FE model.

Automatic mesh generation and application of loads and boundary conditions can also be carried out while creating the finite element model.

It is often necessary to modify design geometry to create an effective finite element model. Automatic mesh generation can be done either through free meshing or adaptive meshing. A comprehensive library of finite elements are available in the software. The elements will be linear or parabolic. Shell, solid, beam, rod, spring, damper, mass and gap are some of the elements available for the purpose of modeling. A FE modeling software provides extensive capabilities to define loading and boundary conditions to correctly simulate the environment that a part will be subjected in operation.

##### **Loads can be:**

- Structural loads
- Heat transfer loads

Physical and material properties can be obtained from the material database of the solid model. Facilities for mode checking and model optimization are also available.

The optimized model can be solved by any one of the analysis package like ANSYS, NISA, ABAQUS or NASTRAN. Finite element modeling, analysis, simulation and optimization are discussed in the next chapter.

#### 6.33.7 GENERATIVE CNC MACHINING BASED ON SOLID MODELING

The geometry of solid models can serve as the basis for generating CNC codes for manufacturing the component. Solid modeling based generative machining software helps to:

- (i) evolve stock model
- (ii) capture manufacturing planning
- (iii) design the tooling
- (iv) develop feature driven machining programs

Solid modeling based machining software encompasses the complete machining environment. The tool paths generated by it avoid grouping of parts, avoid collision with clamps and optimize motion.

Thus solid modeling technique helps in

- (i) conceptualize the design
- (ii) provide interface to analysis
- (iii) generate NC tool paths

A number of software packages are available now for modeling. Important among them are:

AUTOCAD

IDEAS

PRO/ENGINEER

UNIGRAPHICS

CADDS V

CATIA

CADAM

IEMS

SOLID WORKS

SOLID EDGE

IRON CAD

### 6.34 THE CONCEPTUAL DESIGN PROCESS

Traditionally designers used to make 2-D or 3-D sketches as starting point of shape designs. From these sketches, models in materials like wood, clay, sheet metal or polyurethane foam will be made. These models were then displayed to public or groups of interested persons like management or customers to obtain the customer preferences or reactions or feed back. The final design shape is then arrived at by altering the models created incorporating engineering and manufacturing feedback. This process used to take considerable time and constituted a significant portion of product development cycle time.

With the emphasis on time compression in product development, the accent today is in using the computer itself for conceptual design. Once the shape design is completed, the model data could be transferred to the solid modeling software to complete the design analysis and optimization. The software used for conceptual design is also called computer aided industrial design (CAID) package. CAID package is a conceptual front end of the product development process and are specifically designed to stimulate creativity by providing a wide variety of design options. This tool can quickly create and modify the shape, form and surface qualities of 3D models. A CAID package will have photorealistic rendering and lighting capabilities. Several software packages offer the CAID capabilities. Prominent among them are:

- Alias
- PTC
- SolidWorks
- SDRC
- UGS
- think3
- Raindrop Geomagic
- McNeel & Associates

A conceptual design or CAID package should have the following features:

- Integrated 2D sketching and 3D modeling
- Ease of manipulation of shape, form and texture
- Create and modify freeform bodies
- Presentation capabilities
- Data transfer to mechanical CAD for detailed design

A CAID package will have typically the capabilities like Modeling (Global deformation, curve tools, blend tools, sweep curves, surfacing, scaling, filleting, trimming, offsetting, stitching, aligning, smoothing etc), advanced surfacing and direct modeling functions, sketching, evaluation tools, animation and rendering tools etc.

Styling is very important in automobile design. Automobile styling demands quality, precision and accuracy. CAID packages specially designed for Class-A surfacing are available. These packages incorporate advanced modeling and reverse engineering tools. The major modules of such packages are:

- Cloud point data processing
- Direct, patch based modeling
- Procedural curve based modeling
- Real time diagnostic feedback
- Dynamic surface evaluation
- CAD integration

Cloud point data can be captured by several methods. A popular method is laser scanning. Laser scanners are fast and accurate. Mechanical scanning can also be done. A number of scanners are available to capture cloud point data. The surfaces thus created can be subjected to surface quality evaluation, interactive shading and surface curvature analysis. This technique requires a model to be made in a suitable material.

It is more common to carry out the design by sketching. Using the conceptual design software the design process is carried out in a more or less similar fashion as outlined below:



- i. Create an outline of the model by picking points in a window and letting the software to connect them to form surfaces.
- ii. Use the curves to form the model. Create 3-D surfaces from the curves which each surface is an area enclosed by three or more curves.
- iii. Analyze the quality of the curves to identify and eliminate potential manufacturing problems.
- iv. Improve the model by editing the curves and surfaces to arrive at an aesthetically pleasing design.

The geometry of the model can be created by:

- i. A set of curves that define the geometry which acts as the frame work for the model's surfaces or
- ii. The geometry can be created by using surfaces which are larger than what is required and the geometry can be trimmed to suit the requirements.

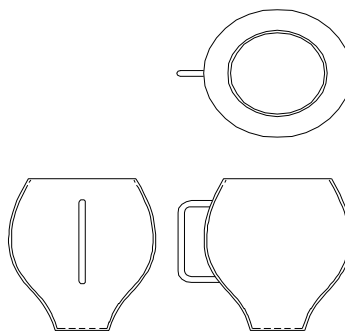
A model can be created using a combination of the above techniques also.

### 6.35 SKETCHING THE GEOMETRY

Conceptual modeling software provides a number of facilities to create sketches. Sketches should be made to scale and should be made with reference to an origin. The sketching can be done in two ways.

**i. Sketch orthogonal views like plan, side view, point view, rear view etc.:**

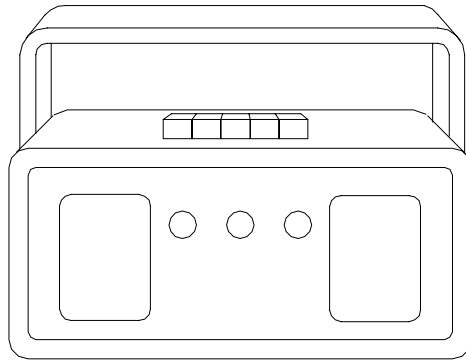
In this method the different views of the object are sketched with the help of orthogonal views as shown in Fig. 6.35. The curve design tools could be used to outline the shape of the model, connect the curves and define the regions which could be later used to create surfaces.



**Fig. 6.35 Shape Design with Orthogonal Sketches**

**ii. Sketch 2-D perspective or 3-D perspective:**

Using the 2-D perspective option is similar to loading a sketch in the side view to create geometry. Fig. 6.36 shows a perspective sketch. In perspective sketching the location of the vanishing point is important. Hand drawn sketches could be scanned and converted into TIFF or similar format and could be loaded into the conceptual modeling software.



**Fig. 6.36 Perspective Sketch**

Once the sketches are loaded, the software can be used to align the sketch.

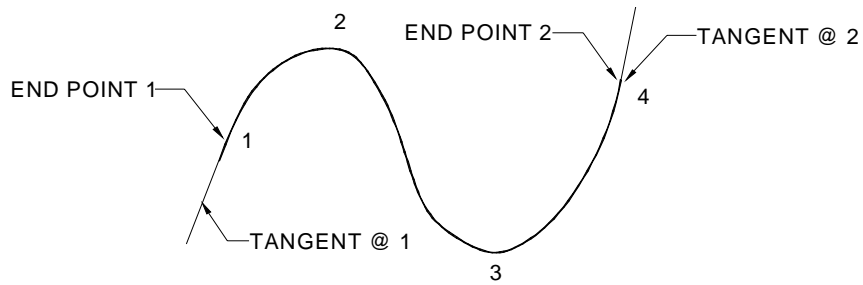
**6.36 UNDERSTANDING CURVE AND SURFACE DESIGN**

Judicious design of curves and surfaces will make a product visually pleasing. The interactive approach for the design of curves and surfaces is briefly described below:

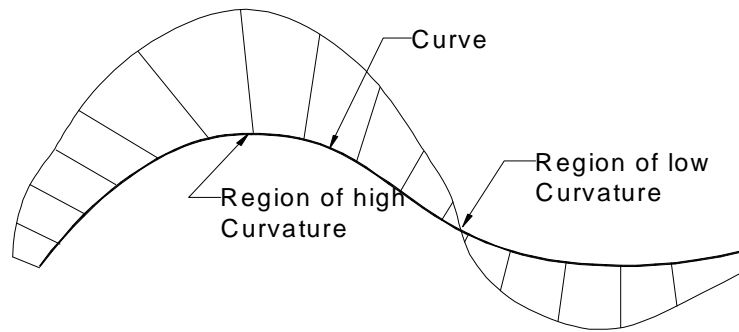
**6.36.1 DESIGN OF CURVES**

A curve is drawn through two or more defining points called control points. Every point on a curve has a position, (X, Y and Z co-ordinates), a tangent and a curvature. The tangent determines the direction of the curve at any given point. The internal points their tangents are created and maintained by the design software.

In Fig. 6.37 a curve is shown to be created using the defining points 1, 2, 3 and 4. The curve passes through the end points 1 and 4 and the direction of the curve and shape of the curve are decided by the tangents and the position of control points 2 and 3. By changing the position of control points, the shape can be changed interactively. The curvature at each point is a measure of how rapidly the curve is changing the direction. General curves have a different curvature value at every point. A curvature plot can be used to evaluate a curve. Fig. 6.38 shows a curvature plot.

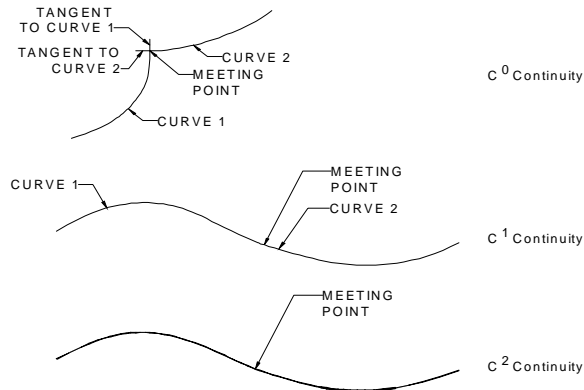


**Fig. 6.37 Curve Design**



**Fig. 6.38 Curvature Plot**

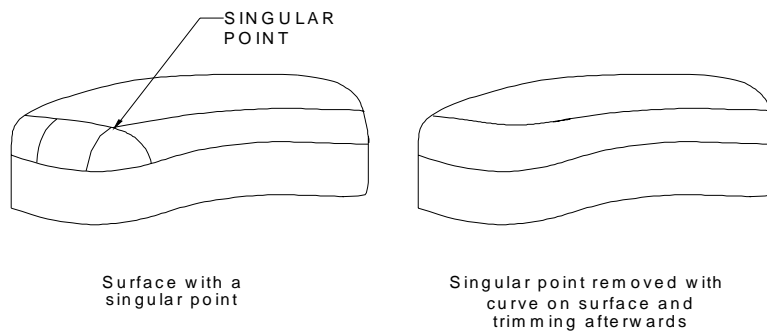
A complex curve required for a product design is usually a continuous combination of several curve segments. There are three measures of curve continuity. The terms  $C^0$ ,  $C^1$  and  $C^2$  continuity levels are used to describe how curves relate to each other.  $C^0$  continuity occurs when two  $C^1$  curves meet at their end points but may not share same tangency or curvature.  $C^1$  continuity occurs when two curves have the same tangent at the matched end points.  $C^2$  continuity is obtained when two  $C^1$  curves have the same curvature at the end point i.e. they have a smooth transition from one curve to another. Fig. 6.39 shows examples for  $C^0$ ,  $C^1$  and  $C^2$  continuity.



**Fig. 6.39  $C^0$ ,  $C^1$  and  $C^2$  Continuity**

### 6.36.2 SURFACES

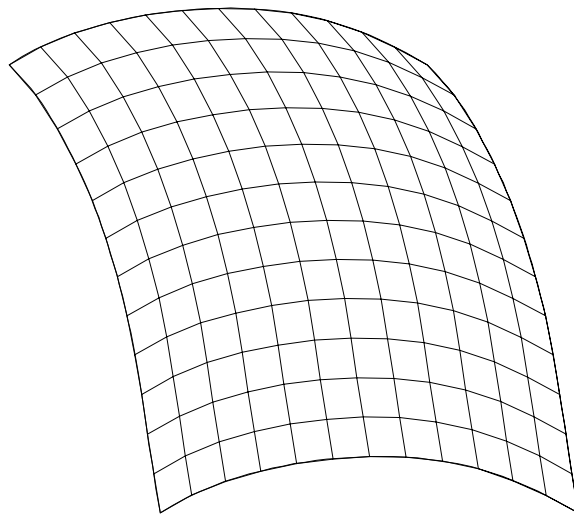
Aesthetic curves are the building blocks for pleasing surfaces which are the key to create good products. The curves that define a surface are called boundary curves. While creating surfaces, surface singularities must be avoided. Fig. 6.40 shows how singularity was avoided by over building the top surface and trimming it with a curve on surface. Avoidance of singularity is important to create a surface design which has good manufacturability.



**Fig. 6.40 Avoiding Singularity**

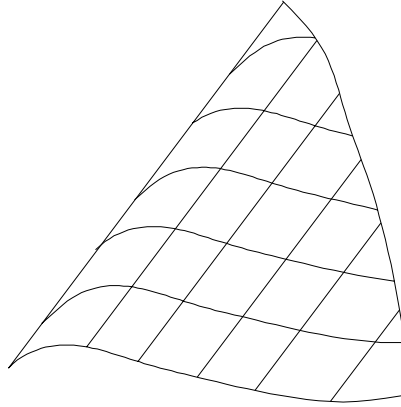
Surfaces have two sides - inside as well as outside. Surface normals are helpful to clearly distinguish the orientation of the surfaces. There can be different surface types:

- i. **Rectangular:** This type of surface is characterized by four boundary curves. (Fig. 6.41)



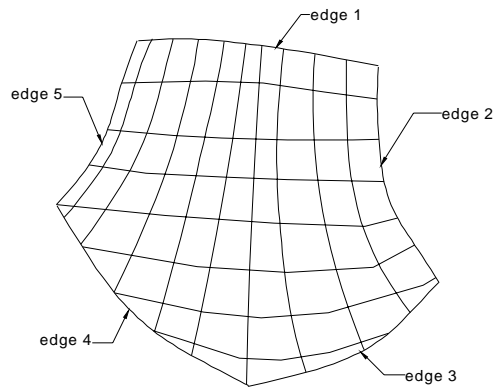
**Fig. 6.41 Rectangular Surface**

- ii. **Triangular:** A surface defined by three boundary curves (Fig. 6.42)



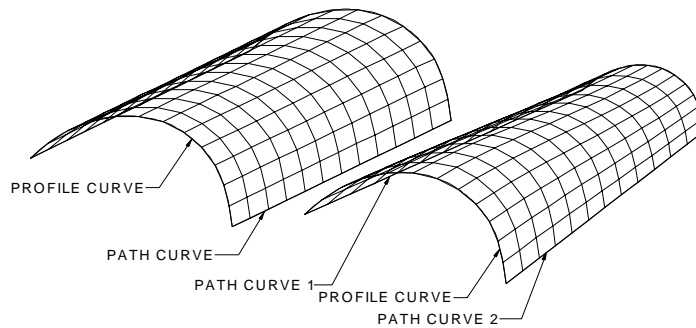
**Fig. 6.42 Triangular Surface**

- iii. **N-sided:** The surface defined by an arbitrary number of curves (Fig. 6.43)



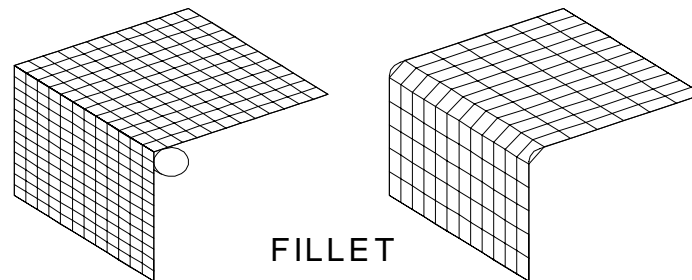
**Fig. 6.43 N-sided Surface**

- iv. **Sweep:** A surface defined by moving a set of profile curves smoothly along one or two guide curves (Fig. 6.44)

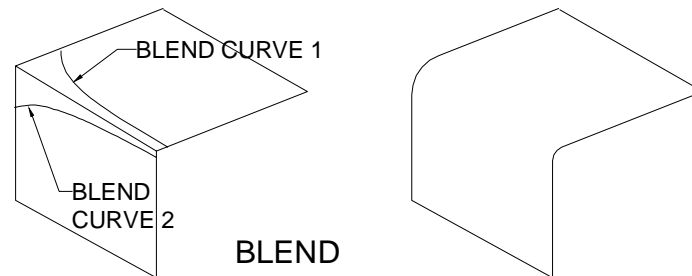


**Fig. 6.44 Sweep Surface**

- v. **Radius fillet:** A blend surface between two sets of surfaces (Fig. 6.45)

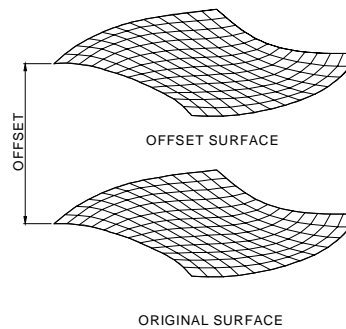


**Fig. 6.45 Fillet Surface**



**Fig. 6.46 Blend**

- vi. **Blend:** This is a special form of sweep. The guide curves are two curves on surface. The blend allows user to blend the surfaces together or make a variable fillet from their defined curves. This type of fillet (Fig. 6.46) needs a curve on each surface for construction.
- vii. **Offset:** An offset surface is created by offsetting a surface at a distance from an existing surface. (Fig. 6.47)



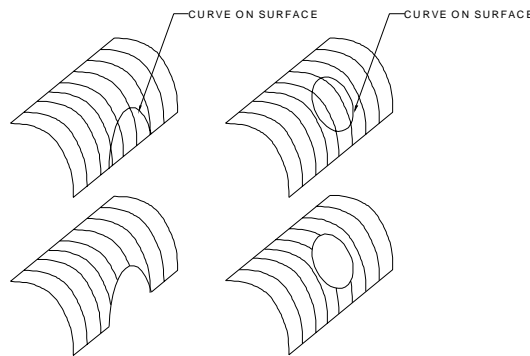
**Fig. 6.47 Offset Surface**

### 6.36.3 EXAMPLES OF OPERATIONS ON SURFACES

Creating a model requires facilities for local modification of surfaces. These facilities are described in the following section:

#### i. Trimming surfaces

A trim is a portion of a surface that can have different attributes. A trimmed surface can be created from an existing surface by specifying a set of curves that partition the original surfaces. Fig. 6.48 shows a trimming operation on a surface.

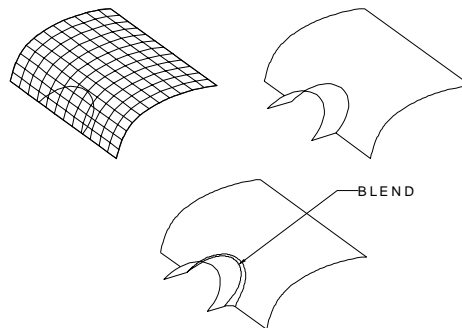


**Fig. 6.48 Trimming**

#### ii. Blending two surfaces

It is often necessary to blend two curved surface. An example is illustrated in Fig. 6.49.

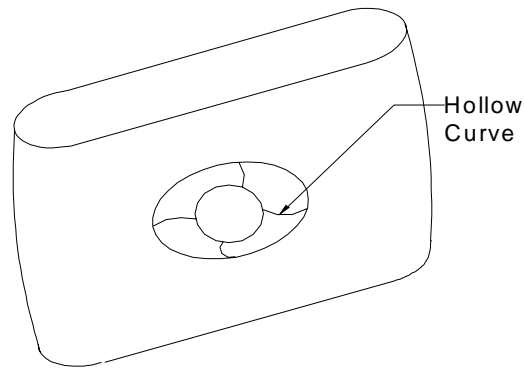
- Create a surface (shown with patches).
- Create a curve outline using curve on surface (COS) tool.
- Project the curve on to the surface and trim the surface.
- Create one more cross sectional curve for the flare.
- Create the flare surface.
- Blend the two surfaces.



**Fig. 6.49 Flare**

**iii. Creating a lens hollow on a camera surface**

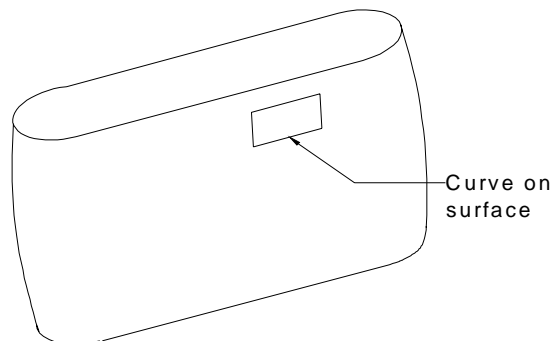
Figure 6.50 shows the surface camera body. It is desired to create a lens hollow. This requires the creation of surfaces that blend smoothly from the main body of the camera into the lens aperture. This can be achieved by creating four curves. An ellipse represents the outer surface of the lens hollow. A circle is to define the geometry of the lens holder. The shape of the connecting surface is defined by two hollow curves. The ellipse and the circle are split at four points. Curves are created the joining the four points on the ellipse and the circle. The tangents are adjusted to make the curves meet the circle and ellipse smoothly. A smooth surface is then created using surface tools.



**Fig. 6.50** Creation of a Lens Hollow on a Camera Body

**iv. Creating a insert for view finder**

A cut out on the camera surface is to be created to locate the view finder. Fig. 6.51 shows the camera body. The cut out is created by a curve on surface (COS) tool.



**Fig. 6.51** Creating a Cut Out Using a Curve on Surface Tool



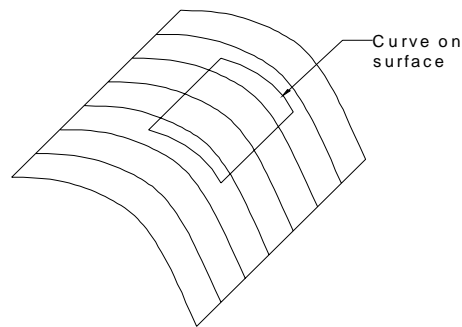
#### 6.36.4 CURVE ON SURFACE (Fig. 6.52)

Curve on a surface (COS) is a special kind of curve. This can be defined by a set of points which are constrained to lie on a surface. COS are very useful in conceptual design because of their use in trimming a surface to blend it with another surface. A COS can be created by:

Projecting a curve on to a surface.

Cutting a planar section through a surface.

Specifying points on a surface through which the curve has to pass through.



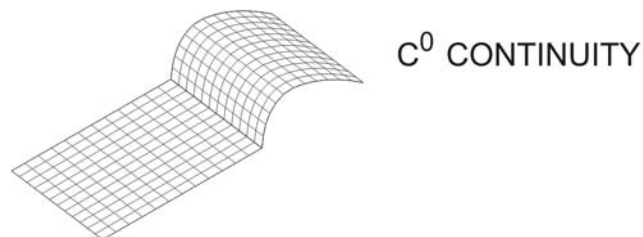
**Fig. 6.52 Curve on Surface**

#### 6.36.5 MEASURES OF SMOOTHNESS OF SURFACES

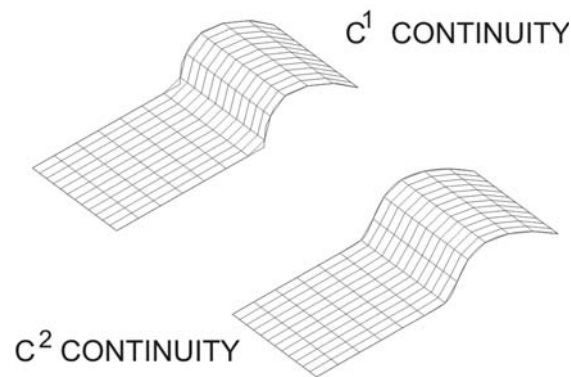
As in the case of curves, smoothness of the boundaries of two surfaces can be ensured by three parameters:

- $C^0$  continuity means that two surfaces share a common boundary.
- $C^1$  continuity. In this case the two surfaces blend tangentially across the shared boundary curve.
- $C^2$  continuity ensures that the boundary of two surfaces have a curvature continuity in addition to position and tangent continuity.

Fig. 6.53 illustrates the three measures of continuity of surfaces. It can be seen that  $C^2$  continuity condition yields smoother surfaces.



**Fig. 6.53 (Contd.)**



*Fig. 6.53 Smoothness of Surfaces*

### 6.37 OTHER FEATURES USEFUL FOR CONCEPTUAL DESIGN

In addition to the sketching facilities, additional features are available to enhance design capabilities:

- i. Photo rendering - Rendering facilitates the evaluation of the model and better communication of design ideas,
- ii. Surfaces can be evaluated by accurate reflections, highlights and shadows. Materials can be applied in the rendering process. Material properties usually available include transparency, brightness and intensity as well as the basic color definition of hue, saturation and brightness.

### 6.38 DATA TRANSFER TO OTHER SOFTWARES

Once the conceptual design is completed, model data can be transferred to other design softwares directly or using neutral files. Many CAID packages provide direct translators to CAD packages like CATIA, Unigraphics, I-DEAS etc.

### QUESTIONS

1. How do you classify modeling package?
2. Compare 2-D and 3-D wire frame models.
3. Discuss the hardware required for a PC based drafting environment
4. Study a CAD package and describe the drawing entities available.
5. What are the commands and their sequence to create 2D and 3D wire frame models of the following components?
  - i. a bracket
  - ii. a spur gear

6. Discuss the use of various editing commands available in a CAD package.
7. Describe the display commands available in a drafting package.
8. How will be set the dimension variables for:
  - i. Aligned dimensioning
  - ii. Unilateral dimensioning
  - iii. Chain dimensioning
  - iv. To indicate the tolerances on dimensions
9. How do you create a block?
10. How do you redefine a block in a drawing?
11. Study the symbol creation facilities available in a drafting package and create symbols for indicating surface roughness
12. Study the various files available in a CAD package and their functions.
13. Write a short note on the advantages of customizing a software.
14. What is meant by configuring a software?
15. How does CAD help drawing office management?
16. How will you create the bill of materials from a CAD file?
17. Describe the importance of curve and surface modeling in computer aided graphics and design.
18. What is the advantage of parametric programming in designing curves and surfaces?
19. Compare the splines for the same control points created by B-spline and Bezier spline techniques.
20. Draw a Bezier spline for the following control points:  
(0,0), (4,3), (8,4) & (12,0)
21. What is the common modeling methods available for surface design in a surface modeling software?
22. Describe briefly the following methods of surface modeling with a few application examples:
  - i. Revsurf
  - ii. Tabcyl
  - iii. Bicubic surface
  - iv. Bezier surface
23. Suggest the procedure that you will adopt to create the following surface geometries:
  - i. The surfaces of the vanes and inner projections of the shroud of a mixed flow impeller.
  - ii. The surface of a propeller.

24. Exercises
  - i Create an assembly of a reduction gearbox and prepare geometric models of individual components.
  - ii Create a surface model of a mouse.
  - iii Create a solid model of a bracket and extract plan, elevation, end view and a sectional view, with dimensions.
  - iv Create a frame type structure in C.I and extract mass properties.
25. Create a solid model and generate a STEP file. Write a program to extract all flat surfaces and holes.
  - i. Study typical consumer durable products like electric iron, coffee percolator, water heater etc. and analyze the impact of shape design on their sales appeal.
  - ii. Study the shape of a passenger car and analyze how the blending of various surfaces of body panels is done.
  - iii. Compare the measures of continuity of curves and surfaces.
26. Study typical consumer durable products like electric iron, coffee percolator, water heater etc. and analyze the impact of shape design on their sales appeal.
27. Study the shape of a passenger car and analyze how the blending of various surfaces of body panels is done.
28. Compare the measures of continuity of curves and surfaces.

## PROJECT

1. Obtain a cloud of points on the surface of an impeller blade and create a smooth surface, using CAD software.
2. Create the surface model of a product of your choice.  
(a toy car, a blender, desktop grinder, shampoo bottle, a two-in-one transistor cum tape recorder, head lamp of a passenger car, etc.).

**This page  
intentionally left  
blank**

# FINITE ELEMENT MODELING AND ANALYSIS IN CIM

*Finite element modeling (FEM) and finite element analysis (FEA) are used today in several fields of engineering and technology. Finite element analysis is one of the powerful techniques for not only design but also for manufacturing applications. Therefore, FEA has an important role in CIM. This chapter gives a brief account of the technique and surveys some applications of this technique. A few examples from design and a brief review of applications to manufacturing simulation are given in this chapter.*

## 7.1 INTRODUCTION

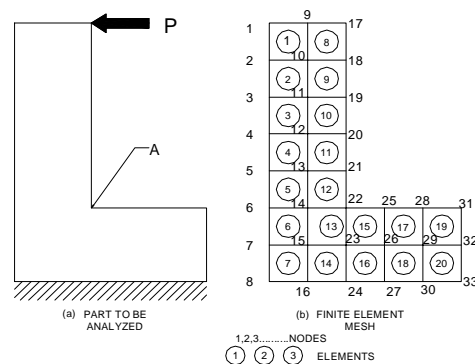
Traditional approach to design analysis involves the application of classical or analytical techniques. This approach has the following limitations:

- i. Stresses and strains are obtained only at macro level. This may result in inappropriate deployment of materials. Micro level information is necessary to optimally allocate material to heavily stressed parts.
- ii. Adequate information will not be available on critically stressed parts of the components.
- iii. It may be necessary to make several simplifications and assumptions to design complex components and systems, if design analysis is carried out in the conventional manner.
- iv. Manual design is time consuming and prone to errors.
- v. Design optimization is tedious and time consuming.

FEA is a convenient tool to analyze simple as well as complex structures. The use of finite element analysis is not restricted to mechanical engineering systems alone. FEA finds extensive application in electrical engineering, electronics engineering, micro electro mechanical systems, biomedical engineering etc. In manufacturing, FEA is used in simulation and optimization of manufacturing processes like casting, machining, plastic molding, forging, metal forming, heat treatment, welding etc. Structural, dynamic, thermal, magnetic potential and fluid flow problems can be handled with ease and accuracy using FEA.

FEA was initially developed in 1943 by R. Courant to obtain approximate solution to vibration problems. Turner et al published in 1956 a paper on "Stiffness and Deflection of Complex Structures". This paper established a broader definition of numerical analysis as a basis of FEA. Initially, finite element analysis programs were mainly written for main frame and mini computers. With the advent of powerful PC's, the finite element analysis could be carried out with the help of several FEA software packages. Finite element method can be applied to a variety of design problems concerning automobiles, airplanes, missiles, ships, railway coaches and countless other engineering and consumer products.

The finite element method is a numerical procedure. This method involves modeling the structure using a finite number of small interconnected elements. Consider the plate shown in Fig. 7.1 (a). Suppose that it is acted upon by a force  $P$  as shown and our interest is to determine the stresses in the plate. The plate is discretized into 20 of elements and 33 nodes as shown in Fig. 7.1 (b). Nodes in this case are the corner points of each element which have a square shape. The nodes are numbered 1 to 33. Each element is formed by four nodes. For example, nodes 1,9,10,2 form element 1. The elements are numbered 1 to 20.



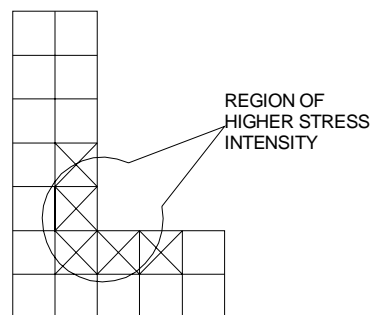
**Fig. 7.1 Finite Element Modeling**

A displacement function is associated with each element. Every interconnected element is linked to other neighboring elements through common interfaces (nodes, edges and surfaces). Using the stress- strain relationship of the material of the part under analysis, the designer can determine the behavior of given node. The set of equations describing the behavior of all nodes results in a set of algebraic equations. These equations are expressed in matrix form.

The solution obtained by finite element analysis is approximate. The accuracy of solution may depend on the type of element used and the number of elements. It is necessary to have a thorough understanding of the physics of the problem to select the most appropriate element for a given problem. It is advisable to try a number of solutions by increasing the number of elements until the relative error in successive solutions is small. In Fig. 7.1 the size of all elements are shown equal. This need not be strictly adhered

to. In fact, automatic mesh generation may result in elements of varying sizes. As long as the aspect ratio of the elements is within permissible limits, the variation in the size of the elements does not matter.

It may be necessary to refine the mesh to improve the accuracy of the solution in specific parts of the component being analyzed. For example, referring to Fig. 7.1, we can state by intuition that the intensity of stress around point A will be more. It is therefore advisable to refine the mesh around point A. An example of refined mesh is shown in Fig. 7.2. Five more nodes have been added and the number of elements is now 35. This may yield a better solution to the stress intensity.



**Fig. 7.2 Mesh Refinement**

## 7.2 GENERAL STEPS INVOLVED IN FINITE ELEMENT ANALYSIS

In this section, a brief account of the general steps in FEA with reference to a structural problem is given. In a structural problem the designer's interest is to determine the stresses and displacements throughout the structure. There are two general approaches. In the force or flexibility method, the internal forces are the unknowns. Equilibrium equations are used to obtain the governing equations. Stress-strain compatibility equations yield additional equations. This results in a set of algebraic equations for determining the unknown forces. In the displacement or stiffness method, the displacements of the nodes are the unknowns. The compatibility conditions ensure that elements connected to a common node, along a common edge or on a common surface before loading remain connected at that node or edge or surface after deformation. The governing equations are then expressed in terms of nodal displacements using equations of equilibrium and the law relating force and displacement. The steps involved in a finite element modeling and analysis procedure are summarized in the following sections.

### 7.2.1 SELECT THE ELEMENT TYPE AND DISCRETIZE THE COMPONENT

The first step is to select an element which closely represents the physical behaviour of the structure. The size of the elements to start with is a matter of judgment of the designer. The selection of the element is discussed later in this chapter.



### 7.2.2 SELECT A DISPLACEMENT FUNCTION

A displacement function within the element using the nodal values of the element is then defined. These may be linear, quadratic or cubic polynomials. The same displacement function is used for all the elements. Hence in the finite element model a continuous quantity like displacement is approximated by a discrete model composed of a set of piecewise-continuous functions defined in each finite element.

### 7.2.3 DEFINE STRESS STRAIN RELATIONSHIP

Definition of stress strain relationship for each element is the next step. For example in the case of one dimensional deformation, if  $u$  is the displacement in the direction  $X$ , the strain is related to the displacement by the relation

$$\varepsilon_x = du/dx \quad (7.1)$$

The stresses are related to the strains through the stress strain law or constitutive law. Using Hooke's law, the stress strain law can be written as:

$$\sigma_x = E \varepsilon_x \quad (7.2)$$

where  $\sigma_x$  is the stress in the  $X$  direction and  $E$  is the modulus of elasticity.

### 7.2.4 DERIVE THE ELEMENT STIFFNESS MATRIX

The stiffness matrix could be derived by the direct equilibrium method or work or energy method or method of weighted residuals. In direct equilibrium method the stiffness matrix and the element equations related to nodal forces are obtained using force equilibrium conditions. In the energy method, the principle of virtual work, the principle of minimum potential energy and Castigliano's theorem are used to develop the matrix. Galerkin's method is used in the case of weighted residuals.

Using any of the above methods, the equations describing the behavior of an element can be written in matrix form as:

$$\begin{Bmatrix} f_1 \\ f_2 \\ f_3 \\ - \\ - \\ f_n \end{Bmatrix} = \begin{bmatrix} k_{11} & k_{12} & k_{13} & - & k_{1n} \\ k_{21} & k_{22} & k_{23} & - & - \\ k_{31} & k_{32} & - & - & - \\ - & - & - & - & - \\ - & - & - & - & - \\ k_{n1} & - & - & - & k_{nn} \end{bmatrix} \begin{Bmatrix} d_1 \\ d_2 \\ d_3 \\ - \\ - \\ d_n \end{Bmatrix} \quad (7.3)$$

This may also be written in the form  $\{f\} = [k] \{d\}$  where  $\{f\}$  is the vector of element nodal forces,  $[k]$  is the element stiffness matrix and  $\{d\}$  is the displacement vector.

### 7.2.5 ASSEMBLE GLOBAL STIFFNESS MATRIX

The individual element stiffness matrices are then assembled to obtain the global stiffness matrix of the whole component being analyzed. The global stiffness matrix is written as:

$$[F] = [K]\{d\} \quad (7.4)$$

where  $[F]$  vector of global nodal forces,  $[K]$  is the global stiffness matrix and  $\{d\}$  is the vector of unknown displacements.

### 7.2.6 SOLVE TO OBTAIN NODAL DISPLACEMENTS

Pre-multiplying both sides of Eq. 7.4 by the inverse of stiffness matrix we will obtain the solution for the displacements.

### 7.2.7 SOLVE FOR ELEMENT STRAINS AND STRESSES

Strains can be computed from the displacements. Once the strain is known the stress can be calculated using Hooke's law. Principal stresses, shear stresses, von Mises stresses (equivalent stress) etc. could be computed depending on the interest of the designer.

The finite element analysis does not stop here. The results are to be interpreted with the aid of nodal data as well as post processed plots of the results. The analysis could be repeated by changing the number of nodes and elements to check if there is convergence between successive analysis results. In case specific areas of the component are to be analyzed in detail to improve the accuracy, the number of nodes and elements in the portions of interest could be increased and analysis repeated. Sub structuring technique could also be adopted. In case the designer is looking for an optimum solution, the analysis could be carried out after defining the objective criterion.

## 7.3 TYPES OF ANALYSIS

Depending upon the type of design problem handled, the finite element analysis can be classified into several types.

### 7.3.1 STRUCTURAL ANALYSIS (STATIC AND DYNAMIC ANALYSIS)

If the analysis involves only the calculation of stresses and deflections in a mechanical component, the analysis is called structural analysis. In this case, the designer creates a finite element model of the component. The structural model thus created can be used to predict the behavior of the real structure, under the action of external forces. The result is usually obtained in terms of nodal deflection and stress. If the loads do not vary with time, this analysis is called static analysis. When the loads vary with time, the analysis is called dynamic analysis. A dynamic force will induce velocities and accelerations that will produce appreciable variations in displacements and stresses depending on the frequency of excitation and the natural frequency of the component analyzed. If the displacement, velocity or acceleration is computed against time, the response is called transient response analysis or steady state analysis depending on the problem.

Another type of dynamic analysis is the computation of the model's natural frequencies of vibration and associated mode shapes. For example, such a type of analysis can be used to study the response of an automobile traveling over a rough terrain at a particular speed. The dynamic force may create uncomfortable vibrations of the whole structure or the vehicle as well as individual parts like the steering wheel or door panel. In the case of a machine tool structure, it is necessary to avoid high amplitudes of vibration of the machine tool, tool, work piece and fixture system to ensure good surface finish on work pieces and better tool life. When designing such components, it is important to avoid natural frequencies, which might get excited in the course of normal operation. Analysis can also be carried out at the design stage to assess the risks to arrive at a robust design.

### **7.3.2 LINEAR AND NON-LINEAR ANALYSIS**

If the properties of the structure, such as stiffness remain constant during the entire analysis, the analysis is called linear. If these properties vary, the analysis is non-linear. Such variation can be due to large displacements in the structure (geometric non-linearity), large scale yielding in the material (material non-linearity) or changes in boundary conditions.

### **7.3.3 THERMAL ANALYSIS**

Finite element analysis can be used for several design and analysis problems involving thermal stresses, thermal displacement, heat flow, temperature distribution etc.

### **7.3.4 FLUID FLOW ANALYSIS**

Finite element analysis can solve several types of fluid flow problems. Fluid flow is very important in many engineering design problems involving aerospace, automobile, chemical engineering, power generation, heating, ventilation, air conditioning, biomedical engineering, combustion, oil and gas, ship design, microfluidics, micropumps etc. Till recently, designers had to resort to experimental studies to verify design assumptions. The improvement in the processing power of personal computers and availability of very powerful programs has made reasonably accurate numerical solutions possible. This field has become very specialized of late and is called computational fluid dynamics (CFD). CFD is now capable of predicting the performance of new designs before they are manufactured.

### **7.3.5 FIELD ANALYSIS (ELECTRICAL, MAGNETIC, ELECTROMAGNETIC AND ELECTROSTATIC)**

Problems in the analysis of magnetic flux and acoustics can be solved by finite element analysis. Example of magnetic analysis is the study of the distribution of magnetic flux in the stator of an electric motor. Field analysis can be applied to the design of radio frequency devices, microwave devices, solenoids, magnets etc.

### **7.3.6 MEMS DESIGN**

The design of micro-electromechanical systems is a specialized field of analysis.

### 7.3.7 MANUFACTURING SIMULATION AND OPTIMIZATION

The importance of modeling and simulation in manufacturing technology is increasing due to the need for continuous reduction of development times. This necessitates the optimization of the production processes, the enhancement of product quality and a reduction of costs. The application of numerical modeling is especially resorted to in the development of new production methods and in the use of new materials. Specialized software solutions are available to optimize the design of castings (solidification analysis), welding process (resistance welding, gas metal arc welding), heat treatment and metal forming (sheet metal processing, tube bending, extrusion, rolling, drawing, forging etc).

Welds are widely used to join structural parts. Residual stresses introduced in the welded regions, due to the nonlinear thermal processes during welding, can have detrimental effects, such as stress corrosion cracking, hydrogen-induced cracking and reduced fatigue strength. It is therefore advantageous to simulate the process of welding to predict residual stresses, weld pool solidification, cooling of welds and resultant thermal deformation.

### 7.4 DEGREES OF FREEDOM

The deformations of the structure are represented by the displacements of the nodes. These displacements are referred to as degrees of freedom, which can be either translational (along X, Y and Z axes) or rotational (about X, Y or Z axes). Each element type will have a predetermined set of degrees of freedom assigned to it.

Figure 7.3(a) shows a cantilever beam. The finite element model of the beam in two dimensions is shown in Fig. 7.3(b).

Each node of the element has three degrees of freedom i.e. translation in X and Y direction and rotation about Z.  $U_i, V_i, \theta_i$  are the translations (displacements) and  $\theta_i$  and  $\theta_j$  are the rotations at the nodes  $i$  and  $j$ .

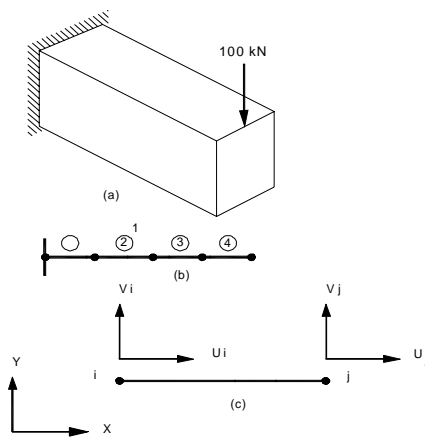


Fig. 7.3 Modeling a Cantilever Beam Using 2-D Beam Elements

## 7.5 INFLUENCE COEFFICIENTS

Three conditions are required to solve any structural design problem:

- (i) Equilibrium of forces
- (ii) Compatibility of deformations
- (iii) Material behavior

The system of equations in FEM is of the form

$$[K] \{U\} = \{F\} \quad (7.5)$$

where

$[K]$  = stiffness matrix

$\{U\}$  = displacement vector

$\{F\}$  = force vector

The stiffness matrix is a collection of terms called influence coefficients. The influence coefficients relating a force at a point to a set of displacements are called stiffness influence coefficients.

$$F = K_{11} u_{11} + K_{12} u_{21} + \dots + K_{1n} u_{n1} \quad (i = 1 \text{ to } n) \quad (7.6)$$

A typical term  $K_{ij}$  is defined as a force at the  $i$ th node due to a unit displacement at the  $j$ th node with all other displacements held fixed.

## 7.6 ELEMENT AND STRUCTURE STIFFNESS EQUATIONS

A finite element model can be constructed out of several types of elements-spring, spar, beam, plate, shell, membrane, pipe, solid etc. A model can be constructed by a single type of element or a combination of different types of elements. This finite element model created for analysis is only an approximate representation of actual structure. As in all numerical methods, computation is performed on the simplified structure. Simplifications are implied in many modeling decisions. For example, each type of element implies certain geometric approximations and automatically imposes certain constraints on displacements and variations of stress over the area of the structure it represents. The level of accuracy desired again dictates the size of the element. A linear displacement element (constant stress and strain element) employed to represent an area, which exhibits little stress variation, does not much impair the values of the results regardless of how large the area represented may be. However, if a single such element is used to model an area over which the stress varies appreciably, the results will be much less accurate. If a membrane element is used to model a structure, which undergoes considerable out-of plane bending, the results will be meaningless. In such cases, a shell element should be used. Similarly, in a dynamic problem, if the time step chosen in computing transient response is large, the results will be inaccurate, with higher frequency response damped out or unstable. If the time step is too small, the computation may become unnecessarily expensive.

In short, an efficient and meaningful finite element analysis is possible only if the designer understands beforehand approximately how the structure behaves, where to expect high stress gradients, and so on. An appreciation of the theoretical assumptions underlying the derivation of the element's stiffness matrix and of the computational algorithms involved also enhances the effectiveness of the analysis. Brief descriptions of some of the commonly used elements are given below:

### 7.6.1 SPRING ELEMENT

The spring element shown in Fig. 7.4 consists of 2 nodes with a single degree of freedom (axial deflection) at each node.

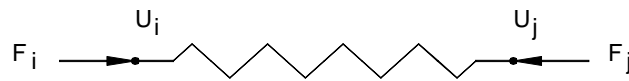


Fig. 7.4 Spring Element

Subscripts  $i$  and  $j$  represent the nodes and  $u_i$  and  $u_j$  are the displacement at the nodes.  $F_i$  and  $F_j$  are the forces at the nodes.  $K$  is the stiffness of the element. From the definition of stiffness, the influence coefficient,  $K_{ij} = -K_{ji} = +K$

The matrix representation of the stiffness equation of a single spring is then:

$$\begin{bmatrix} K & -K \\ -K & K \end{bmatrix} \begin{Bmatrix} u_i \\ u_j \end{Bmatrix} = \begin{Bmatrix} F_i \\ F_j \end{Bmatrix} \tag{3}$$

A system of springs is an assemblage of these elements. (See Fig. 7.4). The assembly procedure is based on principle of superposition. Through superposition stiffness terms corresponding to a given degree of freedom are summed.

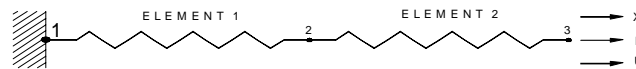


Fig. 7.4 Linear Spring System

To do this, element matrices must be expanded by rows and columns so that the all matrices are of the same order. It is much easier to visualize this assemblage if the columns of each element matrix are labeled by their corresponding degree of freedom. For element 1 the expanded stiffness matrix is given below:

$$\begin{bmatrix} u_1 & u_2 & u_3 \\ K & K & 0 \\ -K & K & 0 \\ 0 & 0 & 0 \end{bmatrix} \quad (7.6)$$

Similarly for element 2, the expanded stiffness matrix are given below:

$$\begin{bmatrix} u_1 & u_2 & u_3 \\ 0 & 0 & 0 \\ 0 & K & -K \\ 0 & -K & K \end{bmatrix} \quad (7.7)$$

The order of the matrices are identical so that like terms may be added. The resulting stiffness matrix is

$$\begin{bmatrix} K & -K & 0 \\ -K & K+K & -K \\ 0 & -K & K \end{bmatrix} \quad (7.8)$$

The equation of response to the spring system becomes

$$\begin{bmatrix} K & -K & 0 \\ -K & K+K & -K \\ 0 & -K & K \end{bmatrix} \begin{Bmatrix} u_1 \\ u_2 \\ u_3 \end{Bmatrix} = \begin{Bmatrix} F_1 \\ F_2 \\ F_3 \end{Bmatrix} \quad (7.9)$$

It can be noted that element stiffness matrix and assembled matrices are symmetrical.

The linear spring system shown in Fig. 7.4 has two springs in series under a load  $F$  at the right end.

The equation of stiffness influence coefficients may be used to write the response equations for this system.

These equations in matrix form are:

$$\begin{bmatrix} K_{11} & K_{12} & K_{13} \\ K_{21} & K_{22} & K_{23} \\ K_{31} & K_{32} & K_{33} \end{bmatrix} \begin{Bmatrix} u_1 \\ u_2 \\ u_3 \end{Bmatrix} = \begin{Bmatrix} F_1 \\ F_2 \\ F_3 \end{Bmatrix} \quad (7.10)$$

The only applied force is  $F_3 = F$  and displacement boundary conditions give  $u_1 = 0$ .

Applying these forces and displacement boundary conditions gives the matrix equations of:

$$\begin{bmatrix} K_{22} & K_{23} \\ K_{32} & K_{33} \end{bmatrix} \begin{Bmatrix} u_2 \\ u_3 \end{Bmatrix} = \begin{Bmatrix} 0 \\ F \end{Bmatrix}$$

$$\begin{bmatrix} K_{12} & K_{13} \end{bmatrix} \begin{Bmatrix} u_2 \\ u_3 \end{Bmatrix} = F_1$$

In the case of spring element, the element co-ordinate system is identical with the global reference co-ordinate system. The assemblage of elements is valid only when all displacements and forces at a node have the same reference co-ordinate system.

**Example:** A short stepped bar 123 is shown in Fig. 7.5. The stiffness of the large section is 12 kN/mm and the stiffness of the small section is 8 kN/mm. End "1" is fixed and an axial load of 6 kN acts at node 3. Determine the displacements at node 2 and node 3.

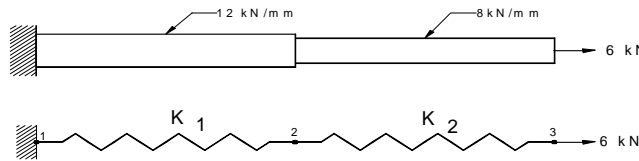


Fig. 7.5 Stepped Bar and Spring Model

**Solution.** Using the matrix equation developed and taking  $u_1 = 0$ .

$$\begin{bmatrix} 12 & -12 & 0 \\ -12 & 20 & -8 \\ 0 & -8 & 8 \end{bmatrix} \begin{Bmatrix} 0 \\ X_2 \\ X_3 \end{Bmatrix} = \begin{Bmatrix} F_1 \\ 0 \\ 6 \end{Bmatrix} \quad (7.11)$$

$$\text{Thus} \quad 20 X_2 - 8 X_3 = 0 \quad (7.12)$$

$$-8 X_2 + 8 X_3 = 6 \quad (7.13)$$

Adding

$$12 X_2 = 6$$

$$X_2 = 0.5 \text{ mm (Answer)}$$

Substituting in (10)

$$10 - 8 X_3 = 0$$

$$X_3 = 0.8 \text{ mm (Answer)}$$

$$\text{Strain in section} \quad 1-2 = X_2 / L_1$$

$$\text{Stress in section} \quad 1-2 = E (X_2 / L_1)$$

$$\text{Strain in section} \quad 2-3 = X_3 / L_2$$

$$\text{Stress in section} \quad 1-2 = E (X_2 / L_2) \text{ where } E \text{ is Young's Modulus.}$$

### 7.6.2 SPAR OR ROD ELEMENT

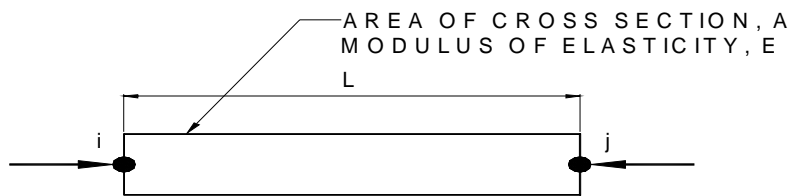
A spar element is one, which can take only axial load, either tensile or compressive. Such elements are used in pin-jointed frames or trusses. Fig. 7.6 shows a spar element. The subscripts refer to element co-ordinate system. The element stiffness matrix for the spar is:



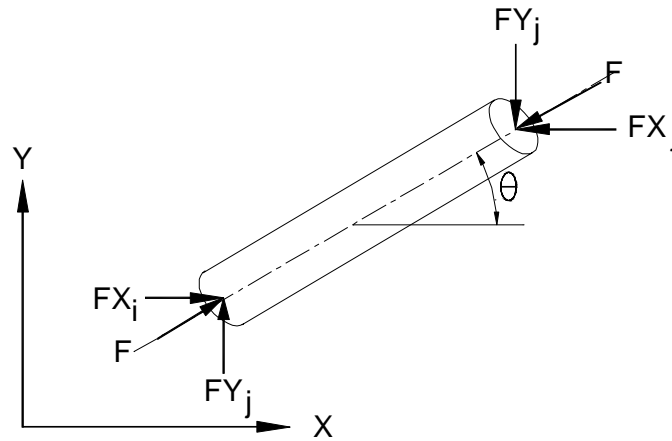
$$[K] = \begin{bmatrix} \frac{AE}{L} & -\frac{AE}{L} \\ -\frac{AE}{L} & \frac{AE}{L} \end{bmatrix} = \frac{AE}{L} \begin{bmatrix} 1 & -1 \\ -1 & 1 \end{bmatrix} \quad (7.14)$$

where  $A$  is the area of cross section of the element and  $E$  is modulus of elasticity of the material.

In the case of spar element the orientation of the element has to be taken into account in determining the stiffness matrix.



**Fig. 7.6 Spar (rod) Element**



**Fig. 7.7 Spar Element Oriented at an Angle  $\theta$**

Consider the pin-jointed member  $ij$  (shown in Fig. 7.7) subjected to a compressive force  $F$  that has components  $F_{X_i}$ ,  $F_{Y_i}$ ,  $F_{X_j}$ ,  $F_{Y_j}$  at the ends. As a result of the structure deforming and the member itself deforming the ends  $i, j$  are displaced by  $u_{X_i}$ ,  $u_{Y_i}$ ,  $u_{X_j}$  and  $u_{Y_j}$ . The member is originally at an angle  $\theta$  to the positive  $X$ -direction. The elongation of the member is given by:

$$e_{ij} = (u_{X_j} - u_{X_i}) \left( \frac{X_j - X_i}{L} \right) + (u_{Y_j} - u_{Y_i}) \left[ \frac{Y_j - Y_i}{L} \right] \quad (7.15)$$

where  $L$  is the length of the member

$$\frac{X_j - X_i}{L} = \cos\theta = l \quad (7.16)$$

$$\frac{Y_j - Y_i}{L} = \sin\theta = m \quad (7.17)$$

Thus

$$\begin{aligned} e_{ij} &= \frac{FL}{AE} \\ &= -\frac{FX_i}{\cos\theta} \frac{L}{AE} = -\frac{FX_i}{l} \frac{L}{AE} \end{aligned} \quad (7.18)$$

$$\begin{aligned} FX_i &= -\frac{EA}{L} l e_j \\ &= -\frac{EA}{L} (l^2 u_j - l m v_j) \\ &= -FX_j \end{aligned}$$

Similarly

$$FY_i = \frac{EA}{L} (U X_i - U X_j) l m + m^2 (U Y_i - U Y_j) = -FY_j \quad (7.19)$$

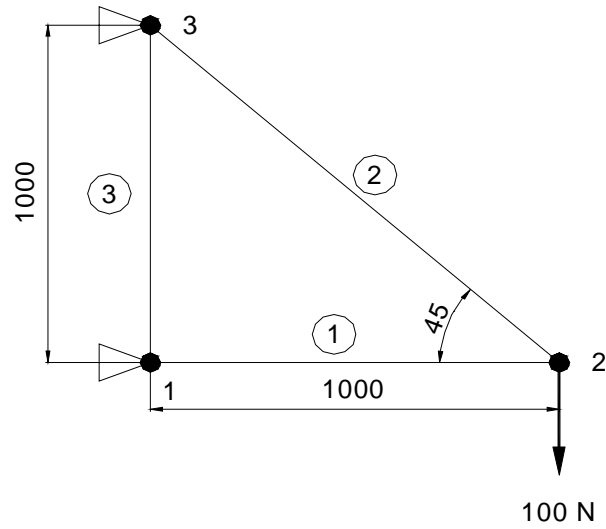
The above equations can be represented by:

$$\frac{EA}{L} \begin{bmatrix} l^2 & lm & -l^2 & -lm \\ lm & m^2 & -lm & -m^2 \\ -l^2 & -lm & l^2 & lm \\ -lm & -m^2 & lm & m^2 \end{bmatrix} \begin{Bmatrix} UX_i \\ UY_i \\ UX_j \\ UY_j \end{Bmatrix} = \begin{Bmatrix} FX_i \\ FY_i \\ FX_j \\ FY_j \end{Bmatrix} \quad (7.20)$$

$[K]$ 
 $\{U\}$ 
 $\{F\}$   
Stiffness
Displacement
Load Vector  
Matrix
Vector

**Example 1:** Figure 7.8 shows a truss consisting of three elements whose  $EA/L$  value is 500 N/mm. Calculate the deflection at node 2.

**Solution.** The nodes are marked 1,2,3 and elements (1), (2), and (3). For element (1), using equation (19) and  $l = 1$ ,  $m = 0$  as  $\theta = 0$



**Fig. 7.8 A Three Element Truss**

$$\frac{EA}{L} \begin{bmatrix} 1 & 0 & -1 & 0 \\ 0 & 0 & 0 & 0 \\ -1 & 0 & 1 & 0 \\ 0 & 0 & 0 & 0 \end{bmatrix} \begin{Bmatrix} UX_1 \\ UY_1 \\ UX_2 \\ UY_2 \end{Bmatrix} = \begin{Bmatrix} FX_1' \\ FY_1' \\ FX_2' \\ FY_2' \end{Bmatrix} \quad (7.21)$$

For element (2),  $l = -0.707 \text{ m} = 0.707$

$$\frac{EA}{L} \begin{bmatrix} 0.5 & -0.5 & -0.5 & 0.5 \\ -0.5 & 0.5 & 0.5 & -0.5 \\ -0.5 & 0.5 & 0.5 & -0.5 \\ 0.5 & -0.5 & -0.5 & 0.5 \end{bmatrix} \begin{Bmatrix} UX_2 \\ UY_2 \\ UX_2 \\ UY_2 \end{Bmatrix} = \begin{Bmatrix} FX_2' \\ FY_2' \\ FX_2' \\ FY_2' \end{Bmatrix} \quad (7.22)$$

For element (3),  $l = 0$  and  $m = 1$

$$\frac{EA}{L} \begin{bmatrix} 0 & 0 & 0 & 0 \\ 0 & 1 & 0 & -1 \\ 0 & 0 & 0 & 0 \\ 0 & -1 & 0 & 1 \end{bmatrix} \begin{Bmatrix} UX_3 \\ UY_3 \\ UX_1 \\ UY_1 \end{Bmatrix} = \begin{Bmatrix} FX_3' \\ FY_3' \\ FX_1' \\ FY_1' \end{Bmatrix} \quad (7.23)$$

Combining equations (21), (22) and (23)

$$\frac{EA}{L} \begin{bmatrix} 1 & 0 & -1 & 0 & 0 & 0 \\ 0 & 1 & 0 & 0 & 0 & -1 \\ -1 & 0 & 1.5 & -0.5 & -0.5 & 0.5 \\ 0 & 0 & -0.5 & 0.5 & 0.5 & -0.5 \\ 0 & 0 & -0.5 & 0.5 & 0.5 & -0.5 \\ 0 & -1 & 0.5 & -0.5 & -0.5 & 1.5 \end{bmatrix} \begin{Bmatrix} UX_1 \\ UY_1 \\ UX_2 \\ UY_2 \\ UX_3 \\ UY_3 \end{Bmatrix} = \begin{Bmatrix} FX_1 \\ FY_1 \\ FX_2 \\ FY_2 \\ FX_3 \\ FY_3 \end{Bmatrix} \quad (7.24)$$

The boundary conditions for node displacement are:

$$UX_1 = 0, UY_1 = 0, UX_3 = 0, UY_3 = 0 \quad (7.25)$$

$$FY_2 = -100 \quad (7.26)$$

Equation (24) now becomes:

$$\frac{EA}{L} \begin{bmatrix} 1 & 0 & -1 & 0 & 0 & 0 \\ 0 & 1 & 0 & 0 & 0 & -1 \\ -1 & 0 & 1.5 & -0.5 & -0.5 & 0.5 \\ 0 & 0 & -0.5 & 0.5 & 0.5 & -0.5 \\ 0 & 0 & -0.5 & 0.5 & 0.5 & -0.5 \\ 0 & -1 & 0.5 & -0.5 & -0.5 & 1.5 \end{bmatrix} \begin{Bmatrix} 0 \\ 0 \\ UX_2 \\ UY_2 \\ 0 \\ 0 \end{Bmatrix} = \begin{Bmatrix} FX_1 \\ FY_1 \\ 0 \\ -100 \\ FX_3 \\ FY_3 \end{Bmatrix} \quad (7.27)$$

Solving equation (25)

$$\frac{EA}{L}(1.5UX_2 - 0.5UY_2) = 0 \quad (7.28)$$

$$\frac{EA}{L}(-0.5UX_2 + 0.5UY_2) = -100 \quad (7.29)$$

From equations (26) and (27)

$$UX_2 = -0.2 \text{ mm (Answer)}$$

Substituting in equation (27)

$$500(-0.5 \times -0.2 + 0.5 UY_2) = 100$$

$$0.1 + 0.5 UY_2 = 0.2$$

$$0.5 UY_2 = 0.1$$

$$UY_2 = 0.2 \text{ mm (Answer)}$$

### 7.6.3 BEAM ELEMENT

Analysis of pin-jointed frames is an ideal or limiting condition in structural analysis since no rotational restraints are supplied at the frictionless pin joints and consequently, no

moments are transmitted through the joint from member to member. The inclusion of moments results in an extra degree of freedom at each joint. The members are now beams and the analysis is called beam element analysis.

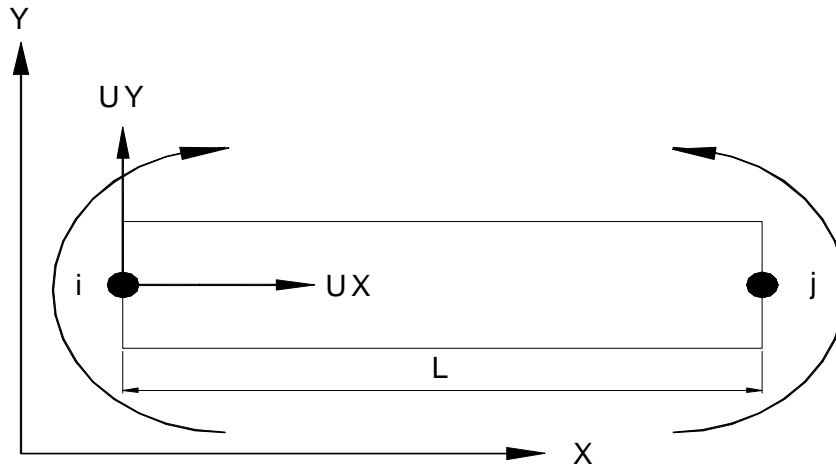


Fig. 7.9 Beam Element

Consider the uniform beam  $ij$  of length  $L$  shown in Fig. 7.9. It carries no transverse loading along its length but it is forced to take up prescribed displacements  $UX_i$ ,  $UY_i$  and  $UX_j$ ,  $UY_j$  at its ends  $i$ , and  $j$  and prescribed slopes or rotations  $\theta_i$  and  $\theta_j$ .

The force displacement relationship for this element is given by:

$$\begin{bmatrix} \frac{EA}{L} & 0 & 0 & -\frac{EA}{L} & 0 & 0 \\ 0 & \frac{12EI}{L^3} & \frac{6EI}{L^2} & 0 & \frac{12EI}{L^3} & \frac{6EI}{L^2} \\ 0 & \frac{6EI}{L^2} & \frac{4EI}{L} & 0 & -\frac{6EI}{L^2} & \frac{2EI}{L} \\ -\frac{EA}{L} & 0 & 0 & \frac{EA}{L} & 0 & 0 \\ 0 & -\frac{12EI}{L^3} & -\frac{6EI}{L^2} & 0 & \frac{12EI}{L^3} & -\frac{6EI}{L^2} \\ 0 & \frac{6EI}{L^2} & \frac{2EI}{L} & 0 & \frac{6EI}{L^2} & \frac{4EI}{L^2} \end{bmatrix} \begin{Bmatrix} UX_i \\ UY_i \\ \theta_i \\ UX_j \\ UY_j \\ \theta_j \end{Bmatrix} = \begin{Bmatrix} FX_i \\ FY_i \\ M_i \\ FX_j \\ FY_j \\ M_j \end{Bmatrix} \quad (7.30)$$

$$\text{Thus} \quad [K]\{U\} = \{F\} \quad (7.31)$$

If the beam is assumed to be oriented at an angle  $\theta$  to the global co-ordinate system,

$$\{F\} = [T]\{F'\} \quad (7.32)$$

Where  $T$  is the transformation matrix

$$[T] = \begin{bmatrix} l & -m & 0 & 0 & 0 & 0 \\ m & l & 0 & 0 & 0 & 0 \\ 0 & 0 & l & 0 & 0 & 0 \\ 0 & 0 & 0 & l & -m & 0 \\ 0 & 0 & 0 & m & l & 0 \\ 0 & 0 & 0 & 0 & 0 & l \end{bmatrix} \quad (7.33)$$

From equation (29)

$$\{F'\} = [K]\{U'\} \quad (7.34)$$

$$[T]\{U'\} = \{U\} \quad (7.35)$$

From equation (30)

$$[T]\{F'\} = \{F\} \quad (7.36)$$

$$[T]\{F'\} = [K'] [T]\{U'\} \quad (7.37)$$

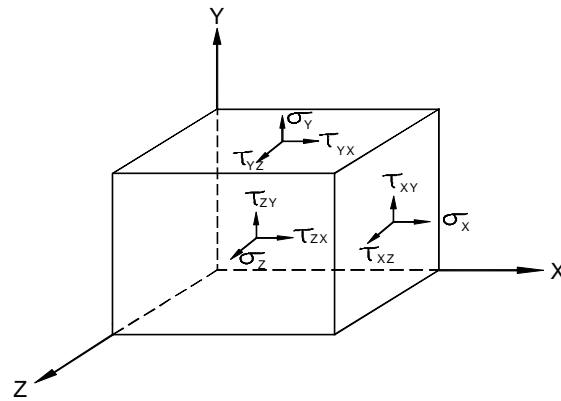
$$\{F\} = [T]^{-1} [K'] [T]\{U'\} \quad (7.38)$$

OR

$$\{F\} = [K]\{U\} \quad (7.39)$$

#### 7.6.4 PLANE STRESS/PLANE STRAIN FINITE ELEMENT ANALYSIS

Development of element matrices for structures other than springs and spars by the above procedure would be difficult. Two of the most common methods used in such cases are the direct and variational methods. Both these methods depend upon choosing a displacement function to describe the relationship between displacement and the co-ordinates of the nodes of the elements. The displacement function enables the elements to simulate the actual displacement, strain and stress behavior within the chosen elasticity theory. For example, a linear displacement function models linear deflection patterns, but only constant stresses and strains within the element.



**Fig.7.10 3-D Stress**

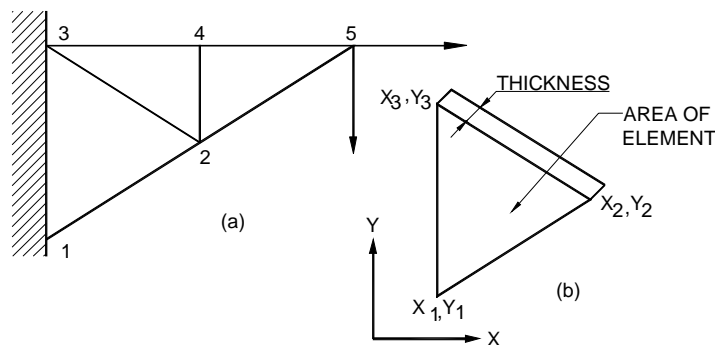
Figure 7.10 shows a body in a state of 3-D stress and strain. The stresses on the body are:

- (a) Direct stresses (tensile or compressive) in  $X$ ,  $Y$  and  $Z$  directions.
- (b) Shear stresses in  $XY$ ,  $YZ$ ,  $ZX$  planes  $\tau_{xy}, \tau_{yz}, \tau_{zx}$

A body is said to be in a state of plane stress if  $\sigma_z = 0$  and through thickness displacement is unrestricted. In plane strain, the strain in the  $Z$  direction is equal to zero ( $\epsilon_z = 0$ ). The body is in a state of three dimensional of stress, the magnitude of  $\sigma_z$  being equal to  $\nu(\sigma_x + \sigma_y)$ .

### **Principal Stresses**

Although compound stress components may be analyzed separately, their resultant effect on an element could be more critical than individual values. At any point within an element there are three mutually perpendicular planes, each with a resultant normal stress. Planes inclined at particular angles will be subjected to only normal stress values. These planes are called principal planes and the stresses are called principal stresses.



**Fig. 7.11 A Triangular Plate**

The finite element approach to continuum problems is developed as a direct extension of the approach used in earlier sections. The method is outlined with respect to a thin triangular plate shown in Fig. 7.11. It is fixed along its edge 1-3 and loaded at 5. It is required to find the displacements under the loads and stresses in the plate. The plate is shown divided into 3 elements with 5 nodes.

The simplest assumption for the deformation within an element is a uniform state of strain throughout. This may be achieved by assuming displacements  $UX$  and  $UY$  to be given by linear functions of  $x$  and  $y$ , the global co-ordinates.

Therefore,

$$UX = \alpha_1 + \alpha_2 x + \alpha_3 y \quad (7.40)$$

$$UY = \beta_1 + \beta_2 x + \beta_3 y \quad (7.41)$$

The corresponding strains are

$$\varepsilon_x = \frac{\partial u}{\partial x} = \alpha_2 \quad (7.42)$$

$$\varepsilon_y = \frac{\partial u}{\partial y} = \beta_2 \quad (7.43)$$

$$\gamma_{xy} = \frac{\partial u}{\partial y} + \frac{\partial v}{\partial x} = \alpha_3 + \beta_2 \quad (7.44)$$

It can be seen that strains are constant. Using equations (38) and (39) the nodal displacements can be written as:

$$\{U\} = \begin{Bmatrix} UX_1 \\ UY_1 \\ UX_2 \\ UY_2 \\ UX_3 \\ UY_3 \end{Bmatrix} = \begin{bmatrix} 1 & X_1 & Y_1 & 0 & 0 & 0 \\ 0 & 0 & 0 & 1 & X_1 & Y_1 \\ 1 & X_2 & Y_2 & 0 & 0 & 0 \\ 0 & 0 & 0 & 1 & X_2 & Y_2 \\ 1 & X_3 & Y_3 & 0 & 0 & 0 \\ 0 & 0 & 0 & 1 & X_3 & Y_3 \end{bmatrix} \begin{Bmatrix} \alpha_1 \\ \alpha_2 \\ \alpha_3 \\ \beta_1 \\ \beta_2 \\ \beta_3 \end{Bmatrix} \quad (7.45)$$

$$= [A]\{\alpha\} \quad (7.46)$$

Similarly

$$\{\varepsilon\} = \begin{Bmatrix} \varepsilon_x \\ \varepsilon_y \\ \gamma_{xy} \end{Bmatrix} = \begin{bmatrix} 0 & 1 & 0 & 0 & 0 & 0 \\ 0 & 0 & 0 & 0 & 0 & 1 \\ 0 & 0 & 1 & 0 & 1 & 0 \end{bmatrix} \begin{Bmatrix} \alpha_1 \\ \alpha_2 \\ \alpha_3 \\ \beta_1 \\ \beta_2 \\ \beta_3 \end{Bmatrix} \quad (7.47)$$



$$= [B_\alpha] \{\alpha\} \quad (7.48)$$

$$\{\varepsilon\} = \frac{1}{2A} \begin{bmatrix} b_1 & 0 & b_2 & 0 & b_3 & 0 \\ 0 & a_1 & 0 & a_2 & 0 & a_3 \\ a_1 & b_1 & a_2 & b_2 & a_3 & b_3 \end{bmatrix} \{U\} \quad (7.49)$$

$$= [B] \{U\} \quad (7.50)$$

Where

$$\begin{aligned} a_1 &= X_3 - X_2 & \text{and} & & b_1 &= Y_2 - Y_3 \\ a_2 &= X_1 - X_3 & & & b_2 &= Y_3 - Y_1 \\ a_3 &= X_2 - X_1 & & & b_3 &= Y_1 - Y_2 \end{aligned}$$

$A$  = area of triangular element.

In plane stress, the through thickness stress  $\sigma_z = 0$  and through thickness displacements are unrestricted.

Thus,

$$\sigma_x = \frac{E}{1-\nu^2} [\varepsilon_x + \nu\varepsilon_y] \quad (7.51)$$

$$\sigma_y = \frac{E}{1-\nu^2} [\varepsilon_y + \nu\varepsilon_x] \quad (7.52)$$

$$\tau_{xy} = G\gamma_{xy} \quad (7.53)$$

or in matrix form

$$\{\sigma\} = \begin{Bmatrix} \sigma_x \\ \sigma_y \\ \tau_{xy} \end{Bmatrix} = \begin{bmatrix} \frac{E}{1-\nu^2} & \frac{\nu E}{1-\nu^2} & 0 \\ \frac{\nu E}{1-\nu^2} & \frac{E}{1-\nu^2} & 0 \\ 0 & 0 & \frac{E}{2(1+\nu)} \end{bmatrix} \begin{Bmatrix} \varepsilon_x \\ \varepsilon_y \\ \gamma_{xy} \end{Bmatrix} \quad (7.54)$$

$$= [D] \{\varepsilon\} \quad (7.56)$$

where

$$E = 2G(1+\nu).$$

The coefficients of  $D$  matrix for plane stress are:

$$d_{11} = d_{22} = \frac{E}{1-\nu}$$

$$d_{21} = d_{12} = \frac{\nu E}{1-\nu}$$

$$d_{33} = \frac{E}{2(1+\nu)}$$

In plane strain  $\varepsilon_z = 0$  and  $\sigma_z = \nu(\sigma_x + \sigma_y)$ .

For plane strain

$$d_{11} = d_{22} = \frac{E}{(1+\nu)(1+2\nu)}$$

$$d_{12} = d_{21} = \frac{E}{(1+\nu)(1-2\nu)}$$

$$d_{33} = \frac{E}{2(1+\nu)}$$

Substituting equation (7.50) in (7.55)

$$\{\sigma\} = [D]\{\varepsilon\} = [D][B]\{U\} \quad (7.56)$$

To obtain a set of nodal forces in equilibrium with the stresses in the element, the principle of virtual work is made use of.

The variational approach of virtual work is based upon the potential energy equation of the system. The potential energy is designated as

$$\pi_p = U + W \quad \text{where } U \text{ is the internal energy and}$$

$$W \text{ is work done by external force.}$$

$$U = \frac{1}{2} \int \{\sigma\}^T \{\varepsilon\} dv$$

$$W = \int \{P\}^T \{U\} dv$$

Where  $\{\sigma\}$  = body forces,  $\{U\}$  = displacements.

The principle of virtual work states that the sum of the work done by the applied force and the stored energy for the virtual displacement is zero.

$$U' + W' = 0$$

where

$U'$  is the change in strain energy for the virtual displacement.

$W'$  is the work done by the virtual displacement.

This principle is extremely useful in developing finite element equations. The stiffness matrix is obtained from the expression in strain energy and the applied force from the expression for the work done.

The following approach is employed for the virtual work development of elements:

- (i) Assume a generalized displacement field.
- (ii) Compute the generalized coefficients in terms of nodal displacements.
- (iii) Compute strains in terms of nodal displacements.
- (iv) Use stress strain relationship to derive a stress displacement relationship
- (v) Substitute these stresses and strains into the strain energy expression and integrate over the volume to get the stiffness matrix.
- (vi) Substitute nodal displacement expressions in the equations of work done to get nodal equivalent forces.

$$\text{i.e.,} \quad \iiint \{\varepsilon\}^T \{\sigma\} dv = \{U\}^T \{P\}$$

$$\iiint \{U\}^T \{B\} [D] \{U\} dv = \{U\}^T \{P\} \quad (7.57)$$

$$t.A \{U\}^T [D] [B] \{U\} v = \{U\}^T \{P\}$$

$$\text{or} \quad [K] \{U\} = \{P\}$$

where  $[K]$ , the stiffness matrix is given by

$$[K] = t.A.[B][D][B] \quad (7.58)$$

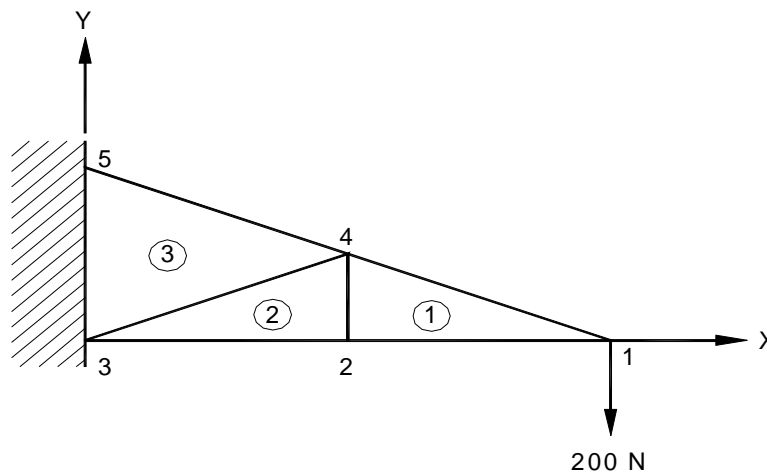


Fig. 7.12 Example

**Example:** Figure 7.12 shows a triangular lamina divided into three elements. Nodes are numbered 1, 2, 3, 4 and 5 and elements are numbered 1, 2 and 3. Assume a unit thickness and Poisson’s ratio,  $\nu = 0.3$ .

**Hint:** Using equations (7.49) and (7.55) calculate [B] and [D]. Assemble element stiffness matrices to obtain global stiffness matrix.

**7.6.5 EXAMPLES OF OTHER ELEMENT SHAPES AND DISPLACEMENT FUNCTIONS**

In the preceding section it was shown that use of linear displacement functions for the plane stress and plane strain triangular elements leads to constant stresses and strains throughout the elements. Figure 7.13 shows a triangular element with 3 corner nodes and additional nodes in the middle of the edges. If the displacements at the six nodes are known, the displacements at any point (x,y) in the element can be calculated in terms of their co-ordinates x and y.

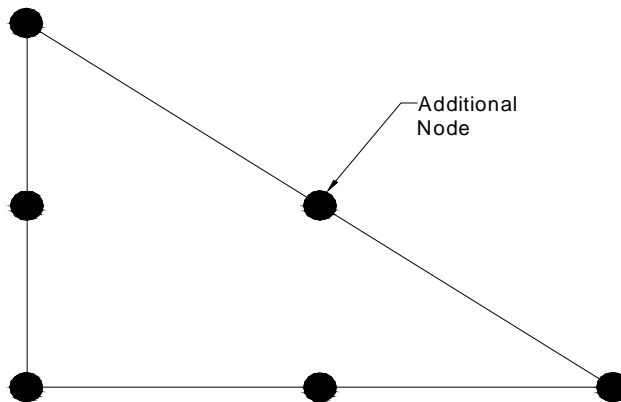


Fig. 7.13 Triangular Element

The displacements can be expressed as:

$$UX = a_1 + a_2X + a_3Y + a_4X^2 + a_5XY + a_6Y^2 \tag{7.59}$$

$$UY = a_7 + a_8X + a_9Y + a_{10}X^2 + a_{11}XY + a_{12}Y^2 \tag{7.60}$$

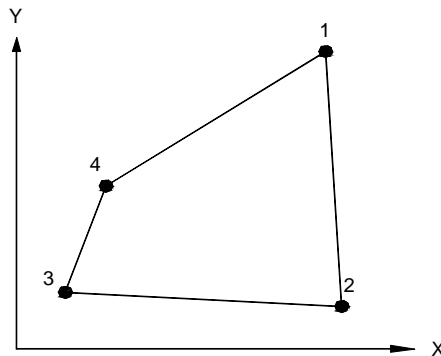


Fig. 7.14 Quadrilateral Element

Figure 7.14 shows a quadrilateral element with 4 edges and 4 nodes. The displacement functions for this element can be written as

$$UX = a_1 + a_2X + a_3Y + a_4XY \quad (7.61)$$

$$UY = a_5 + a_6X + a_7Y + a_8XY \quad (7.62)$$

Choice of displacement function is a key point for development of elements. The choice affects convergence and is directly involved in the computation of all element matrices. The main criteria for choice are:

- (i) Assumed displacement function must be continuous within the element.
- (ii) The displacements are compatible with adjacent element displacements.
- (iii) The displacement function must be able to represent all constant strain states within the elements. It means that as element gets smaller stress within the element must approach a constant value.
- (iv) All rigid body modes of the element must be represented.
- (v) Element strain energy should be invariant to changes in node numbering or element co-ordinate axis changes.

## 7.7 ASSEMBLY OF ELEMENTS

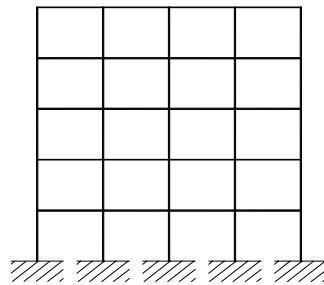
The equilibrium of a structure composed of many elements is defined by

$$[K] \{u\} = \{F\}$$

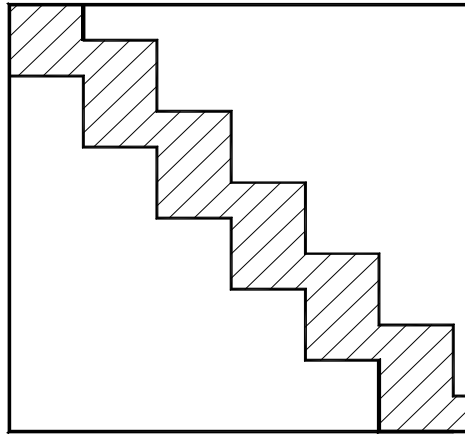
where  $[K]$  is the global stiffness matrix,  $\{u\}$  are the nodal displacements and  $\{F\}$  is the nodal force vector.

The characteristics of the global stiffness matrix that are important to computer storage requirements and an efficient solution are discussed below:

- (i) **Positive definiteness.** Consider a two-dimensional model of a frame structure shown in Fig. 7.15. The global stiffness matrix is obtained by summing the matrices of the individual elements. The stiffness matrix of the structure will show that all diagonal elements are positive. The stiffness matrix consists of non-zero values either side of the diagonal. Terms away from the diagonal have zero values. This is shown in Fig. 7.16.



**Fig. 7.15 2-D Frame Structure**



**Fig. 7.16 Global Stiffness Matrix**

It shows that we can reduce the global stiffness matrix into a smaller size that will make the solution process easier and quicker.

- (ii) **Symmetry:** The global stiffness matrix is always symmetric. Because of symmetry only half the global matrix coefficients have to be stored, thereby saving storage space.

**Banded matrix:** It can be seen that the global stiffness matrix has a large number of coefficients that are zeros.

In the stiffness assembly procedure, the element matrices were expanded to the size of the entire system equation by adding rows and columns of zeros for the system degrees of freedom that did not exist in the given element. For small problems this could be the feasible assembly procedure. Two matrix arrays of the size of the total number of degrees of freedom of the system would be required. One would be used and reused for each element computation. The other would store assembled matrices. Storage memory requirement for this type of procedure would be enormous for structures with large degrees of freedom. Common methods of reducing memory requirements include:

$$\begin{array}{cccccc}
 x & x & x & 0 & 0 & 0 \\
 x & x & x & x & 0 & 0 \\
 x & x & x & x & x & 0 \\
 0 & x & x & x & x & x \\
 0 & 0 & x & x & x & x \\
 0 & 0 & 0 & x & x & x
 \end{array}$$

**Fig. 7.17 Banded Nature of Stiffness Matrix**

$$\begin{array}{cccc}
 x & x & x & x \\
 x & x & x & x \\
 x & x & x & x \\
 x & x & x & x \\
 x & x & x & x \\
 x & x & x & x
 \end{array}$$

**Fig. 7.18 Generation of Smaller Matrices using Half Band Width**

- (i) Taking advantage of the banded nature of the stiffness matrix (i.e. its symmetry about the principal diagonal, with groups of zeros at opposed corners, Fig. 7.17).
- (ii) By ignoring corner zeros and using a half bandwidth value, a smaller stiffness matrix may be generated. This is shown in Fig. 7.18.

	1	2	3	4	5	6	7	8	9	
	10	11	12	13	14	15	16	17		18
	19	20	21	22	23	24	25	26	27	

	1	4	7	10	13	16	19	22	25	
	2	5	8	11	14	17	20	23	26	
	3	6	9	12	15	18	21	24	27	

**Fig. 7.19 Reordering of Elements**

- (iii) The wave front or frontal solver technique requires only a part of the assembled matrix.

This procedure uses the order of the input of element data to establish an array of counters used in the assembly procedure. This counter array contains the element number for the first use and last use of every degree of freedom of the total stiffness matrix.

Since the solution procedure associated with this assembly technique does not store the total stiffness matrix at one time, only an arbitrary size array of storage is zeroed before assembly begins. The size of this array determines the size of the problem that can be solved and is known as maximum wave front allowed. The individual element matrices are computed, transformed and added to the portion of total stiffness that is actively stored. Superposition is automatic since the assembly procedure does keep track of which degrees of freedom are active. If a new degree of freedom is introduced, a new row and column are created. If a degree of freedom already exists, the stiffness term is added to the existing total stiffness stored.

The portion of the total stiffness matrix stored for this method is initially a sparse matrix. However, the solution procedure (Gauss elimination) does tend to expand the non-zero terms to most of all off-diagonal elements. Therefore the storage procedure cannot make use of the reduction in storage required if only the initial non-zero terms are saved. The storage required for the assembled matrix is dependent upon the number

of active degrees of freedom within the assembled matrix. This number is called the wave front size. The active degrees of freedom are those that still have other elements that will contribute to them. If an active degree of freedom is closed, assembly is finished so no more elements contribute to it and this degree of freedom is eliminated by Gauss elimination process.

To reduce maximum wave front size, the elements must be ordered from the solution phase so that element for which each node is mentioned first is as close as possible in sequence to the element for which it is mentioned last. In geometric terms, the element should be ordered so that the wave front sweeps through the model continuously from one end to the other in the direction in which it has the largest number of nodes. For example, consider a model having 3 nodes in one direction and nine nodes in the other direction as shown in Fig. 7.19. The element should be ordered along one three-node edge and ordering progresses towards the other three-node edge. In this way equations will be deleted from the assembled matrix as soon as possible after they are added, thus minimizing wave front size.

- (iv) Solving the equations for each element in turn whilst storing the others on disc and then writing out the reduced equations to the disc. Back substitution is then used with the reduced equations, which are read back into the core memory.

## 7.8 FINITE ELEMENT ANALYSIS PACKAGES

With the widespread adoption of CAE approach to design, finite element analysis became integrated with the design and analysis process. There are several CAD packages available today with built-in FEA capabilities (I-DEAS, PRO/E, Unigraphics, CATIA etc). There are also several FEA packages with interface to database of solid modeling packages to carryout FE Analysis. FEA packages by themselves possess modeling capabilities (wire frame or solid modeling) so that they can be used independent of CAD software. There are several such software packages available today which can run on mainframes, minicomputers as well as PC's. NASTRAN, NISA, PATRAN, ANSYS, COSMOS, ALGOR, PCTRAN etc., are some of the well-known analysis packages.

### 7.8.1 MODELING CAPABILITIES OF TYPICAL FINITE ELEMENT SOFTWARE PACKAGE

The following list gives some of the capabilities of finite element software packages.

- (i) *Static analysis.* Calculation of stresses and displacements in a structure subjected to static loads.
- (ii) *Dynamic analysis.* Calculation of transient and steady state response of a structure to loads which vary with respect to time.



- (iii) *Modal analysis.* Computation of natural frequencies associated mode shapes of the structure, response spectrum analysis, random vibration and forced vibration problems.
- (iv) *Stability analysis.* Determination of buckling loads on a structure.
- (v) *Heat transfer.* Computation of temperature distribution and heat flow within a structure under steady state and transient conditions.
- (vi) *Field problems.* Analysis of field intensity and flux density of a magnetic field, analysis of field problems in acoustics and fluid mechanics.
- (vii) *Coupling effects.* Solution techniques for interfacing multiple field effects such as displacement, forces, temperature, heat flows, electrical voltage and current, magnetic field intensity and flux, and fluid pressure and velocity.
- (viii) *Non-linear capabilities.* Computations taking into account the temperature dependency of material properties, plasticity, non-linear elasticity, creep, swelling, large deflections, and work hardening.
- (ix) *Material properties.* Analysis of isotropic, orthotropic, sandwich plates, and composites.

Analysis capabilities are today extended to overlay composite solid, laminated composite shell, sandwich shell, fatigue, and fracture. Typical loading situations are concentrated loads, body forces, surface forces, non-zero nodal displacements, nodal temperature gradients etc.

## 7.9 GENERAL STRUCTURE OF A FINITE ELEMENT ANALYSIS PROCEDURE

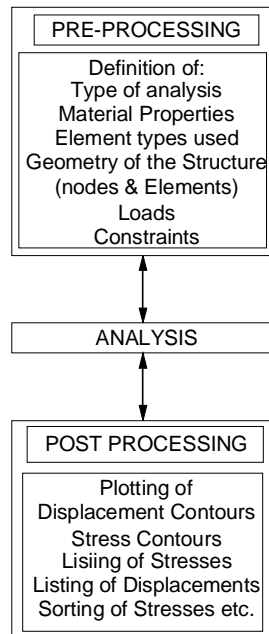
The analysis of a structure during its design process is accomplished by the solution of the partial differential equations which describe the given model. This involves the following three steps (Fig. 7.20).

- (i) The description of the geometry the physical characteristics and the mesh (pre-processing)
- (ii) The application of the finite element analysis (solution)
- (iii) The visualization and interpretation of the results of the solution (post processing).

These three steps are quite distinct and correspond to creating, on the programming level, the three distinct modules:

- (i) Module to enter the data
- (ii) Module to perform the analysis

- (iii) Module to interpret and display the results



**Fig. 7.20 Steps in FEA**

### 7.9.1 PREPROCESSING MODULE

The pre-processing module is used for entering all the information necessary to define the problem. This data relates to the discretization of the structure and the representation of its physical behavior.

The pre-processing module must accomplish the following three functions:

- (i) Description of the geometry of the object in terms of the chosen element types
- (ii) Mesh generation
- (iii) Definition of loading and boundary condition.

The mesh generation consists of forming a collection of nodes and elements which form an acceptable discretization of the structure to be analyzed. Such a discretization must conform to the boundaries of the component and the interfaces between different regions. The shape of the elements must not be too irregular (elongated) and should, as much as possible, resemble the standard elements (triangles or tetrahedra, squares or cubes, etc.).

The nodes are defined by their co-ordinates while the elements are characterized by their type and a list of their nodes. Certain formulations involve boundary integrals. In this case the designer must define not only interior finite elements (volume elements in

three dimensions and surface elements in two dimensions) but also boundary finite elements (surface elements in three dimensions and line elements in two dimensions) on the corresponding boundaries.

It is also necessary to describe the physical characteristics of the elements, such as description of material properties (e.g., thermal conductivity, modulus of elasticity, density, Poisson's ratio); description of heat sources, description of boundary conditions, and description of initial conditions (for time dependent problems).

Generally, this information is entered region by region of the component. The description of the geometry is sometimes implicitly linked to the meshing. However, the trend at present is to separate the two. The description of the geometry is done first and then the mesh is generated. The most extreme case of this separation is the use of two separate specialized programs: a solid modeler for the geometrical input and a mesh generator for the discretization.

More than one type of element can be used in a model, including two dimensional elements where all forces and displacements act in a plane; axisymmetric elements for solids of revolution that are also two-dimensional but have node displacements in radial and axial directions; three-dimensional solid elements where forces and displacements act in all three directions or when a structure has a complex geometry that does not allow two-dimensional analysis. Specialty elements such as plate and beam types are used where sections of a structure behave according to conventional plate and beam theory.

Elements with nodes at vertices generally model only a linear variation of displacement with constant strain. Elements are also available, however, with nodes at edges. These elements can model high-order variations in displacements and strain within an element. Many elements with nodes along their sides are "Isoparametric" where additional nodes allow element sides to form curved boundaries. These elements also increase accuracy. Isoparametric models can cut model construction times but require more processing time per element.

### **7.9.2 PRE-PROCESSING FROM CAD MODEL**

In computer aided engineering the product development starts with a CAD model. This model is then subjected to several types of analysis (FEA, mechanisms analysis etc.) to verify the model and explore modifications to design. This requires the transfer of CAD database to the finite analysis software. This can be carried out broadly in two ways.

#### **(a) Using a preprocessor package**

Commercial packages like HyperMesh are available which will carry out pre-processing of CAD model, so that time consuming tasks of node generation, element generation etc. can be avoided. For example, if the CAD model is made by a PRO/E or CATIA software package, the FEA model can be created by a finite element modeling interface software. The automatic mesh generation facility (volume

meshing or area meshing as the case may be) takes out the tedium of meshing. The model is more accurate as the redefinition of the geometry is avoided.

The advantages of this approach are:

- Reduced time and engineering analysis cost.
- Reduced overhead costs of maintaining multiple pre- and post-processing tools.
- Minimized “new user” learning curves.
- Increased efficiency.
- Open-architecture design and customization functionality.
- Reduced redundancy and model development costs.
- Simplified modeling process for complex geometry through high-speed, high-quality auto meshing, hexa-meshing and tetra-meshing.
- Dramatic increase in end-user modeling efficiency.

There are several ways in which finite element models are created from CAD models. Different meshing approaches are used for creating the models. These are described below:

- (i) **Shell meshing:** Shell meshing is performed using triangular mesh elements. This is designed to mesh surfaces. Surfaces are designated for shell meshing in three ways:
  - (a) *Pair meshing.* In this case, part surfaces are paired so that material is sandwiched between selected surfaces. These surfaces are then compressed together to a single surface using thickness as a property. The shell meshing is done in the compressed plane.
  - (b) *Boundary meshing.* The surface of a part is shell meshed using this option.
  - (c) *Quilt meshing.* Two dimensional features are shell meshed using this option.
- (ii) **Solid meshing:** Solid meshing of interiors of solid is done with tetrahedral elements.
- (iii) **Mixed meshing:** Shell and tetrahedral meshing technique can be used advantageously for many parts. If the model contains thin and thick parts, thin parts can be shell meshed and thick parts can be meshed with tetrahedral elements. The corresponding tetrahedral mesh elements are forced to coincide to provide analytical continuity.

### 7.9.3 PROCEDURE FOR CREATION OF FINITE ELEMENT MODEL FROM SOLID MODEL

The following procedure is recommended to create a finite element model from a solid model:

- (i) Simplify the model by removing features which are unnecessary to the finite element analysis. Features like rounds, chamfers and small holes can be suppressed. Dimensions can be modified to align edges and surfaces are very close. Another way to simplify the model is to use symmetry of the part to be modeled. Only a portion of a symmetrical object needs modeling.

- (ii) Add loads and boundary conditions to surfaces, edges and datum points on the model.
- (iii) If the model is to be shell meshed, define shell model. As mentioned earlier a shell model represents solid features with a network of surfaces formed by pairing and compressing part surfaces together. Pairing of surfaces can be done automatically or manually.
- (iv) Assign material properties to shell pairs and solid elements.
- (v) Use mesh control to determine fineness of the mesh.
- (vi) Mesh the model.
- (vii) Go to step 1 if needed.
- (viii) Output to a specially formatted file for the finite element analysis.

Typical mesh element output formats for some FEA packages are given in Table 7.1

**Table 7.1 Typical Element Output Formats**

<i>Mesh Element</i>		<i>Analysis Package</i>				
		<i>PATRAN</i>	<i>ANSYS</i>	<i>NASTRAN</i>	<i>SUPERTAB</i>	<i>COSMOS</i>
Shell Mesh	Thermal (L)	3 Node (T)	STIF57	-	ENTITY91	STIF57
	Thermal (P)	6 Node (T)	-	-	ENTITY92	-
	Structural (L)	3 Node (G)	STIF63	CTRIA 3	ENTIFY91	STIF63
	Structural (P)	6 Node (G)	STIF93	CTRIA 6	ENTITY92	STIF93
Tetra-hedral Mesh	Thermal (L)	4 Node (T)	STIF70	-	ENTITY111	STIF70
	Thermal (P)	10 Node (T)	STIF87	-	ENTITY118	STIF87
	Structural (L)	4 Node (G)	STIF72	CTRIA	ENTITY111	STIF72
	Structural (P)	4 Node (G)	STIF92	CTRIA	ENTITY118	STIF92
		10 Node (G)				

#### 7.9.4 USE OF NEUTRAL FILES

A neutral file like IGES file or a STEP file can be used to transfer the geometry to FEA. Here the CAD model is converted to a neutral file which is then input to the FEA software using utility software. The geometry can then be used for meshing and additional information necessary can be input to complete the model.

#### 7.9.5 ANALYSIS

In the analysis part, computer solves the unknowns in the finite element problem, i.e., it solves the linear or non-linear system of equations based on the variational or the projective formulation.

Input to analysis module is the finite element model, the physical characteristics and the boundary conditions (pre-processor file). Its output is the value of the unknown quantity at each of the nodes of the grid.

Two large classes of methods are used to solve these sets of equations: point or block methods of relaxation or global matrix methods. The latter, more popular today, requires several steps:

- (i) Creation of sub-matrices and sub-vectors corresponding to each individual finite element;
- (ii) Assembly of these elementary matrices and vectors to build the system matrix and right hand vector;
- (iii) Solution of the linear system of equations.

The solution of linear algebraic systems can be done in several ways: by direct methods (Gauss, Choleski), semi-direct methods, or block iterative methods (Gauss-Seidel). When the system of equations is non-linear, these operations are repeated in an iterative scheme (Gauss-Seidel, Newton-Kantorovich, Newton-Raphson). When the problem is time dependent, these steps must be repeated for each time step (implicit or explicit finite difference methods, Crank-Nicholson, Predictor-Corrector, Guyan reduction techniques, and Householder method).

### 7.9.6 POSTPROCESSOR

The large amount of data is generated in the solution phase (several thousand of nodal values in complex problems). These are often too much to be understood without further processing. The post processor presents the output of the problem in a manner which is easily understood and interpreted by the user.

**The postprocessor performs two tasks:**

- (i) **Extraction of significant information:** The information may be related to local quantities (magnetic flux density, stress distribution) or global quantities (heat flux, electromagnetic forces, etc.).
- (ii) **Synthetic presentation of the numerical data via graphics facilities:** This makes the data more understandable and easier to interpret (stress plots, displacement plots, isothermal plots, temperature Vs time curves, magnetic field along a line, etc.).

### 7.10 ARCHITECTURE OF FINITE ELEMENT SOFTWARE

Finite element software packages are structured in many ways. At one extreme, a pre-and postprocessor may not exist at all. In this case, the input data file can be created with a text editor. The results of the analysis can then be processed directly by the user. In more popular FEA softwares, however, the pre and postprocessors are highly developed to reduce the time involved in the input of data and the analysis of the results of the simulation. They both require high performance interactive graphics modules.

The solution phase, however, needs classical computational resources: arithmetic operations, large primary memory, mass storage, etc. The diversity of facilities (good

interactivity and high quality graphics for pre-and post-processing) and computational power and storage facilities for the solver are the main reasons for the organization of the software in these separate modules, sometimes implemented on different computers (minicomputer for interactive graphics and a mainframe or parallel computer for computation).

The data is transferred from one program to another (perhaps from one computer to another) through various files.

The structure most frequently encountered can be classified into the following three groups:

- (i) **One program for all functions:** When all the functions are contained in a single program, rapid interaction among all operations is facilitated. It is well suited to applications with numerous input/output operations.
- (ii) **One program for pre-and post-processing:** In this case, the user has at his/her disposal all of the interactive facilities and all of the computational facilities. He/she can describe the problem and analyze the results with a high performance interactive graphics terminal (perhaps a mainframe, super or parallel computer).
- (iii) **One program for each function:** This method involves the construction of a set of procedures from different sources. A procedure may be run by means of a set of dedicated programs. For instance, if we have two different mesh generators, one completely automatic, and the other semi-automatic, we can first do an automatic meshing of the problem. Then, if the result does not look good (too many elements, symmetry not taken into account) we can modify the results using the semi-automatic mesh generator. In both cases the problem will use the same solution technique.

## 7.11 USING A FINITE ELEMENT ANALYSIS PACKAGE FOR SIMPLE PROBLEMS

Simple problems can be solved using the modeling facilities available within a FEA package.

To illustrate the use of a PC-based finite element package, the procedure of analysis using ANSYS is discussed in the following sections.

### 7.11.1 MODES OF OPERATION

The mode of operation of a finite element package will vary depending on the type and version of the package. In some cases the pre-processing, analysis and post-processing are carried out by separate modules. Often these segments of the analysis are executed consecutively. The procedure in the case of ANSYS 10 is given below:

All ANSYS data input is written to a ASCII coded file (FILE18.DAT). This file may be saved and is suitable for printout, and reword when analysis is performed. Hence it is necessary to copy this file before analysis if the data is to be preserved. The analysis can be carried out in an interactive or batch mode. In batch mode, the user creates two files-a preprocessing file and a post processing file. These files can be created using an editor.

### 7.11.2 PREPROCESSING

The first step in finite element analysis is creation of a model that breaks a structure into simple standardized shapes or by a common coordinate grid system. The coordinate points, called nodes, are locations in the model where output information is provided.

Finite element packages provide exhaustive element libraries to enable adequate modeling of even complicated parts. A list of elements used in the ANSYS package is given in the next section.

## 7.12 ELEMENTS IN A FINITE ELEMENT ANALYSIS SOFTWARE

Several elements are available in a typical finite element analysis software. Some of them are:

- LINK1 - 2-D Spar (or Truss)
- PLANE2 - 2-D 6-Node Triangular Structural Solid
- BEAM3 - 2-D Elastic Beam
- BEAM4 - 3-D Elastic Beam
- SOLID5 - 3-D Coupled-Field Solid
- COMBIN7 - Revolute Joint
- LINK8 - 3-D Spar (or Truss)
- INFIN9 - 2-D Infinite Boundary
- LINK10 - Tension-only or Compression-only Spar
- LINK11 - Linear Actuator
- CONTAC12 - 2-D Point-to-Point Contact
- PLANE13 - 2-D Coupled-Field Solid
- COMBIN14 - Spring-Damper
- PIPE16 - Elastic Straight Pipe
- PIPE17 - Elastic Pipe Tee
- PIPE18 - Elastic Curved Pipe (Elbow)
- PIPE20 - Plastic Straight Pipe
- MASS21 - Structural Mass
- BEAM23 - 2-D Plastic Beam
- BEAM24 - 3-D Thin-walled Beam
- PLANE25 - Axisymmetric-Harmonic 4-Node Structural Solid
- CONTAC26 - 2-D Point-to-Ground Contact
- MATRIX27 - Stiffness, Damping, or Mass Matrix



---

SHELL28 - Shear/Twist Panel  
FLUID29 - 2-D Acoustic Fluid  
FLUID30 - 3-D Acoustic Fluid  
LINK31 - Radiation Link  
LINK32 - 2-D Conduction Bar  
LINK33 - 3-D Conduction Bar  
LINK34 - Convection Link  
PLANE35 - 2-D 6-Node Triangular Thermal Solid  
SOURC36 - Current Source  
COMBIN37 - Control  
FLUID38 - Dynamic Fluid Coupling  
COMBIN39 - Nonlinear Spring  
COMBIN40 - Combination  
SHELL41 - Membrane Shell  
PLANE42 - 2-D Structural Solid  
SHELL43 - 4-Node Plastic Large Strain Shell  
BEAM44 - 3-D Elastic Tapered Unsymmetric Beam  
SOLID45 - 3-D Structural Solid  
SOLID46 - 3-D 8-Node Layered Structural Solid  
INFIN47 - 3-D Infinite Boundary  
CONTAC48 - 2-D Point-to-Surface Contact  
CONTAC49 - 3-D Point-to-Surface Contact  
MATRIX50 - Superelement (or Substructure)  
SHELL51 - Axisymmetric Structural Shell  
CONTAC52 - 3-D Point-to-Point Contact  
PLANE53 - 2-D 8-Node Magnetic Solid  
BEAM54 - 2-D Elastic Tapered Unsymmetric Beam  
PLANE55 - 2-D Thermal Solid  
HYPER56 - 2-D 4-Node Mixed U-P Hyperelastic Solid  
SHELL57 - Thermal Shell  
HYPER58 - 3-D 8-Node Mixed U-P Hyperelastic Solid  
PIPE59 - Immersed Pipe or Cable  
PIPE60 - Plastic Curved Pipe (Elbow)

SHELL61 - Axisymmetric-Harmonic Structural Shell  
SOLID62 - 3-D Magneto-Structural Solid  
SHELL63 - Elastic Shell  
SOLID64 - 3-D Anisotropic Structural Solid  
SOLID65 - 3-D Reinforced Concrete Solid  
PLANE67 - 2-D Thermal-Electric Solid  
LINK68 - Thermal-Electric Line  
SOLID69 - 3-D Thermal-Electric Solid  
SOLID70 - 3-D Thermal Solid  
MASS71 - Thermal Mass  
HYPER74 - 2-D 8-Node Mixed u-P Hyperelastic Solid  
PLANE75 - Axisymmetric-Harmonic 4-Node Thermal Solid  
PLANE77 - 2-D 8-Node Thermal Solid  
PLANE78 - Axisymmetric-Harmonic 8-Node Thermal Solid  
FLUID79 - 2-D Contained Fluid  
FLUID80 - 3-D Contained Fluid  
FLUID81 - Axisymmetric-Harmonic Contained Fluid  
PLANE82 - 2-D 8-Node Structural Solid  
PLANE83 - Axisymmetric-Harmonic 8-Node Structural Solid  
HYPER84 - 2-D Hyperelastic Solid  
HYPER86 - 3-D Hyperelastic Solid  
SOLID87 - 3-D 10-Node Tetrahedral Thermal Solid  
VISCO88 - 2-D 8-Node Viscoelastic Solid  
VISCO89 - 3-D 20-Node Viscoelastic Solid  
SOLID90 - 3-D 20-Node Thermal Solid  
SHELL91 - Nonlinear Layered Structural Shell  
SOLID92 - 3-D 10-Node Tetrahedral Structural Solid  
SHELL93 - 8-Node Structural Shell  
CIRCU94 - Piezoelectric Circuit  
SOLID95 - 3-D 20-Node Structural Solid  
SOLID96 - 3-D Magnetic Scalar Solid  
SOLID97 - 3-D Magnetic Solid  
SOLID98 - Tetrahedral Coupled-Field Solid

---

SHELL99 - Linear Layered Structural Shell  
VISCO106 - 2-D 4-Node Large Strain Solid  
VISCO107 - 3-D 8-Node Large Strain Solid  
VISCO108 - 2-D 8-Node Large Strain Solid  
TRANS109 - 2-D Electromechanical Solid  
INFIN110 - 2-D Infinite Solid  
INFIN111 - 3-D Infinite Solid  
INTER115 - 3-D Magnetic Interface  
FLUID116 - Thermal-Fluid Pipe  
SOLID117 - 3-D 20-Node Magnetic Solid  
HF118 - 2-D High-Frequency Quadrilateral Solid  
HF119 - 3-D High-Frequency Tetrahedral Solid  
HF120 - 3-D High-Frequency Brick Solid  
PLANE121 - 2-D 8-Node Electrostatic Solid  
SOLID122 - 3-D 20-Node Electrostatic Solid  
SOLID123 - 3-D 10-Node Tetrahedral Electrostatic Solid  
CIRCU124 - General Circuit  
CIRCU125 - Common or Zener Diode  
TRANS126 - Electro-mechanical Transducer  
SOLID127 - 3-D Tetrahedral Electrostatic Solid p-Element  
SOLID128 - 3-D Brick Electrostatic Solid p-Element  
FLUID129 - 2-D Infinite Acoustic  
FLUID130 - 3-D Infinite Acoustic  
FLUID141 - 2-D Fluid-Thermal  
FLUID142 - 3-D Fluid-Thermal  
SHELL143 - 4-Node Plastic Small Strain Shell  
PLANE145 - 2-D Quadrilateral Structural Solid p-Element  
PLANE146 - 2-D Triangular Structural Solid p-Element  
SOLID147 - 3-D Brick Structural Solid p-Element  
SOLID148 - 3-D Tetrahedral Structural Solid p-Element  
SHELL150 - 8-Node Structural Shell p-Element  
SURF151 - 2-D Thermal Surface Effect  
SURF152 - 3-D Thermal Surface Effect

SURF153 - 2-D Structural Surface Effect  
SURF154 - 3-D Structural Surface Effect  
SHELL157 - Thermal-Electric Shell  
HYPER158 - 3-D 10-Node Tetrahedral Mixed u-P Hyperelastic Solid  
LINK160 - Explicit 3-D Spar (or Truss)  
BEAM161 - Explicit 3-D Beam  
PLANE162 - Explicit 2-D Structural Solid  
SHELL163 - Explicit Thin Structural Shell  
SOLID164 - Explicit 3-D Structural Solid  
COMBI165 - Explicit Spring-Damper  
MASS166 - Explicit 3-D Structural Mass  
LINK167 - Explicit Tension-Only Spar  
TARGE169 - 2-D Target Segment  
TARGE170 - 3-D Target Segment  
CONTA171 - 2-D 2-Node Surface-to-Surface Contact  
CONTA172 - 2-D 3-Node Surface-to-Surface Contact  
CONTA173 - 3-D 4-Node Surface-to-Surface Contact  
CONTA174 - 3-D 8-Node Surface-to-Surface Contact  
CONTA178 - 3-D Node-to-Node Contact  
PRETS179 - 2D/3D Pre-tension  
LINK180 - 3-D Finite Strain Spar (or Truss)  
SHELL181 - Finite Strain Layered Shell  
PLANE182 - 2-D 4-Node Structural Solid  
PLANE183 - 2-D 8-Node Structural Solid  
SOLID185 - 3-D 8-Node Structural Solid  
SOLID186 - 3-D 20-Node Structural Solid  
SOLID187 - 3-D 10-Node Tetrahedral Structural Solid  
BEAM188 - 3-D Linear Finite Strain Beam  
BEAM189 - 3-D Quadratic Finite Strain Beam  
SOLID191 - 3-D 20-Node Layered Structural Solid  
INTER192 - 2-D 4-Node Linear Interface  
INTER193 - 2-D 6-Node Linear Interface  
INTER194 - 3-D 16-Node Quadratic Interface  
INTER195 - 3-D 8-Node Linear Interface

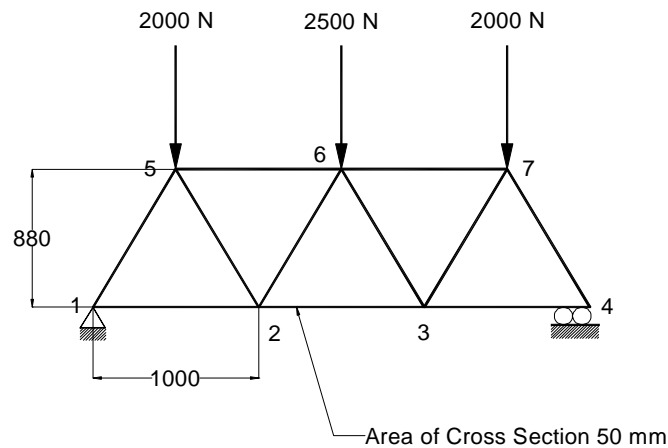
### 7.13 EXAMPLES OF SOLUTION USING A SOFTWARE

Finite element analysis can be carried out using several user-friendly software packages. A few examples are given in this section. Only very simple examples have been chosen as otherwise it will be very lengthy. The purpose is to introduce the methodology to the readers. Readers are, however advised to go through the manuals of the software to understand the correct procedure. Two examples are given here. One is a simple truss and the other a plane stress problem (plate with a hole).

#### 7.13.1 EXAMPLE

Solution for displacements and axial Stresses in a truss.

Figure 7.21 shows a plane truss consisting of 11 members. These are pinned on 7 joints as shown. Joint 1 is pinned and fixed. Joint 4 is pinned but free to move on rollers. Hence the joint can move in the horizontal direction. Loads of 2000 N, 2500 N and 2000 N act on nodes 5, 6 and 7 respectively in a downward direction. It is desired to determine the reactions at Nodes 1 and 4 and the axial stresses in the truss elements as well as displacements at the various nodes.



**Fig. 7.21 Details of Truss**

Since the truss joints are pinned, there is no bending stress in the elements. The elements, therefore will experience only axial stresses.

The procedure given below gives the solution using ANSYS software.

#### **Pre-Processing**

From Utility Menu

Select File > Change Title

Enter new title: Truss

Click OK

From Utility Menu> Plot > Replot

Enter the coordinates of the nodes

Define 7 nodes as given in Table 7.2

**Table 7.2 Coordinates of the Nodes**

Node	Coordinates	
	X	Y
1	0	0
2	1000	0
3	2000	0
4	3000	0
5	500	880
6	1500	880
7	2500	880

From main menu

Preprocessor> Modeling> Create> Nodes> In Active CS

To define the first node

Enter node # as 1

Enter for X 0 and for Y 0

Click Apply

Then enter all the remaining nodes.

Click Ok

Define Geometric properties.

Pre processing > Real Const > Add/Delete/Edit

Click add. Select type 1 Link 1

Add Cross Sectional Area 50 sq. mm

Click on OK

Set 1 now appears in dialog box.

Click on Close.

Define Elements

Pre processor > Element Type > Add/Edit/Delete

Click on Add

Select Element 2D spar.

In Element Type 1 Link 1  
Click Close

Input element material properties:

Pre Processing >Material Props >Material Models >Structural > Linear >  
Elastic > Isotropic  
Enter for EX 21e5.  
Click on OK.  
Close the window.

Create lines connecting nodes.

Use the mouse to connect the nodes.  
Preprocessor > Modeling > Create > Elements > Auto numbered > Thro' Nodes  
Click first Node 1.  
Move the mouse to Node 2 and click.  
A line will appear joining points 1 and 2.  
Left click and a permanent line will appear.  
Connect the remaining key points.  
Click OK.  
Plot > lines.

From Utility Menu

Plot Cntrl > Numbering  
Fill the windows for key points, node and elements  
Save the data.  
Utility Menu > File > Save as....

### ***Solution Phase***

Solution Menu

Define Analysis Type > New analysis

Select Static.  
Click OK

Apply Constraints

In mechanical structures constraints will be fixed, pinned or roller type. In the example, node 1 is pinned and node 4 is on rollers.

In the Solution menu

Define Loads > Apply > structural > Displacement > On Nodes  
Apply U, ROT, on KPS Window

Click on OK

Select All DOF. As all DOF are constrained on Node 1 enter Displacement= 0

Click OK

For Node 4

Apply, U, ROT, on KPS

Select UY. Set value = 0

### Apply Loads

There are three downward loads on nodes 5 (2000n), 6 (2500 N) and 7 (2000N)

Select

Define Loads >Apply > Structural >Force > Moment >On Nodes

Select Node 5

Select FY

Enter the value -2000

Click OK

Apply the remaining loads in a similar manner.

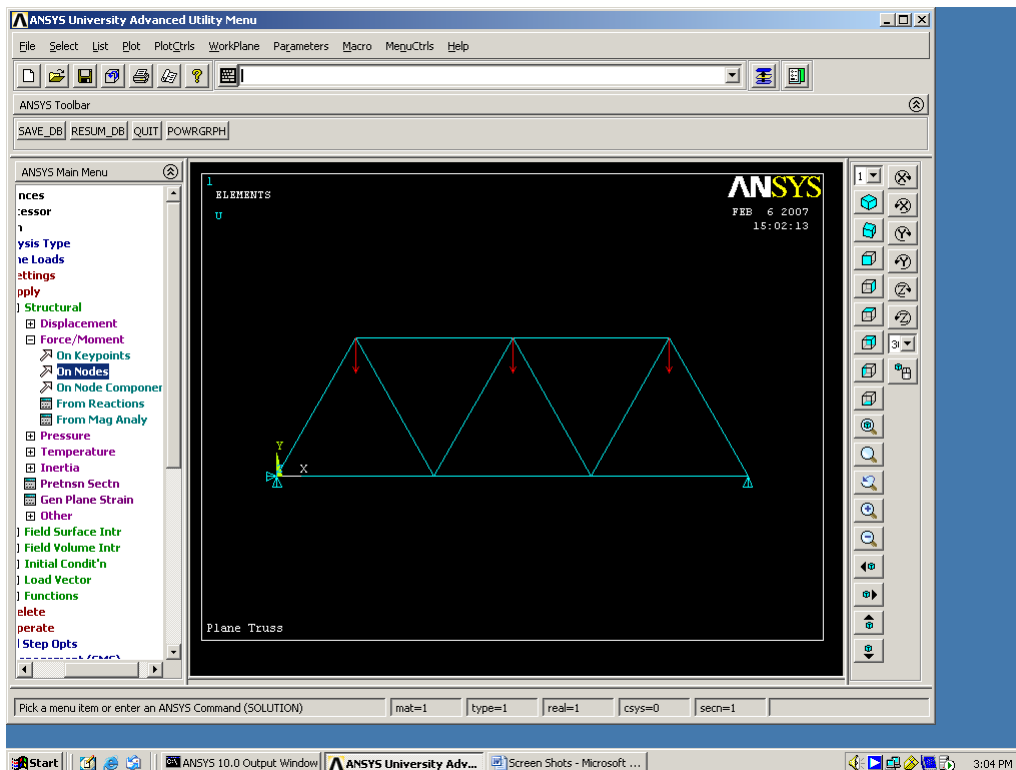


Fig. 7.22 Truss with Loads and Boundary Conditions



Figure 7.22 shows the truss with loads and boundary conditions. The preprocessing is now complete and one can proceed to solution.

Solving the problem:

In the solution menu

Select Solve > Current LS

Click on OK

Click on Close on Pop Up window.

### Post Processing

From Main Menu

General Post Proc >List Results >Reaction Solu.

Select 'All Struct. Force F' and click on OK.

Reaction forces appears on the Screen.

Deformation

General Post Proc >Plot Results >Contour Plot > Nodal Solution

Select DOF solution and Displacement Vector Sum

Click on OK

Plot of the deformed shape will be obtained and is shown in Fig. 7.23.

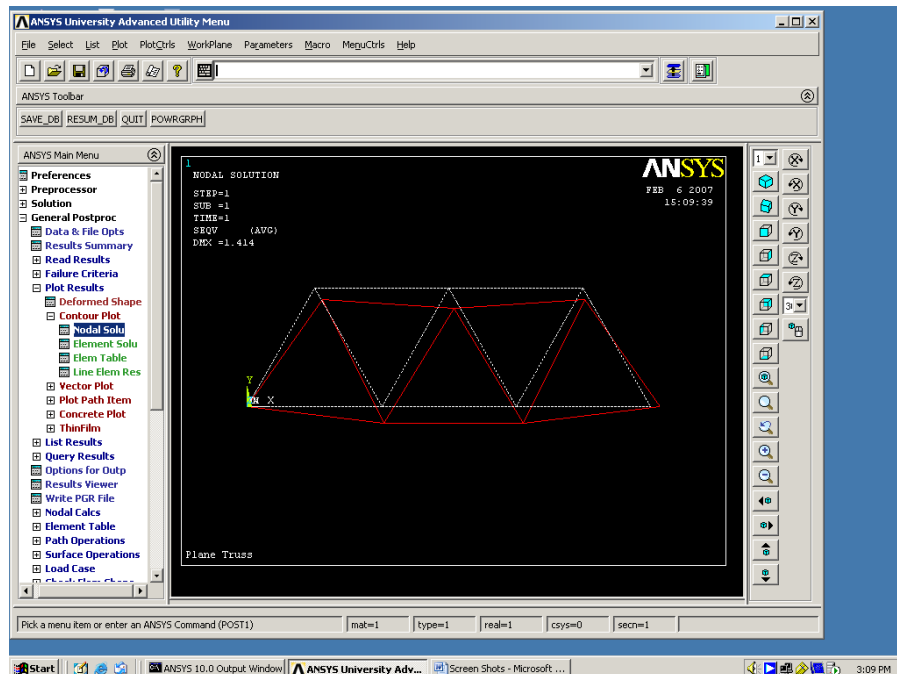


Fig. 7.23 Plot of the Deformed Truss

Listing of Displacements

General Post Proc > List Results > Nodal Solution

The displacements will be listed as shown in Table 7.3.

**Table 7.3 Post1 Nodal Degree of Freedom Listing**

LOAD STEP= 1 SUBSTEP= 1

TIME= 1.0000 LOAD CASE= 0

The following degree of freedom results are in the global coordinate system.

<b>NODE</b>	<b>UX</b>	<b>UY</b>	<b>UZ</b>	<b>USUM</b>
1	0.0000	0.0000	0.0000	0.0000
2	-0.45094E-01	-0.87614	0.0000	0.87730
3	0.45094E-01	-0.87614	0.0000	0.87730
4	0.0000	0.0000	0.0000	0.0000
5	0.24351	-0.55277	0.0000	0.60403
6	0.73777E-16	-1.0611	0.0000	1.0611
7	-0.24351	-0.55277	0.0000	0.60403
<b>MAXIMUM ABSOLUTE VALUES</b>				
NODE	5	6	0	6
VALUE	0.24351	-1.0611	0.0000	1.0611

Axial Stress

General Post Proc > element table > Define Table

Click on Add

Enter SAXL in the 'Lab' window.

In item 'Comp' box select 'By Sequence Number' and 'LS'

Enter 1 for 'LS'

Click on OK

Close Window

Select SAXL in the new window

Click on OK

List Stress Values

From Element Table 'List Element Table'

Click on OK

The axial stresses will be listed as shown in Table 7.4

Table 7.4 Post1 Element Table Listing

<i>ELEM</i>	<i>SAXL</i>
1	-9.4697
2	18.939
3	-9.4697
4	-74.759
5	28.754
6	-28.754
7	-28.754
8	28.754
9	-74.759
10	-51.136
11	-51.136

MINIMUM VALUES

ELEM 9

VALUE -74.759

MAXIMUM VALUES

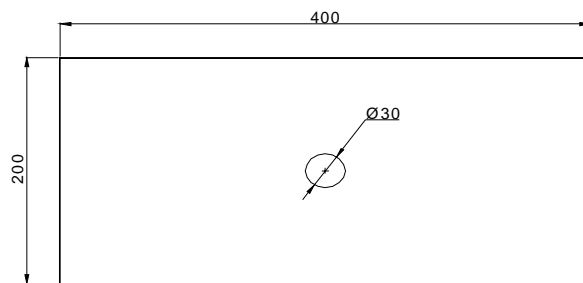
ELEM 8

VALUE 28.754

### 7.13.2 EXAMPLE 2

Deformations and Stresses in a Plate with a Central Hole under Load

Figure 7.24 shows a plate of 400 x 200 x 25 mm size with a central hole of 20 mm diameter. The left edge of the plate is fixed and a uniform pull of 2.5 Mpa per mm length acts on the free right edge. The problem falls under category of plane stress (Stresses in X and Y directions, and no stress in the third dimension. The deformations will be in X, Y and Z directions).



**Fig. 7.24 Plate with a Central Hole**

In this case the model is created using solid modeling approach. A rectangular plate is first created and then a solid circle is created in the center. The circle is subtracted from the plate using Boolean operation to create the component.

The procedure is given briefly in the following sections:

Utility Menu > Change Title

Create the geometry of the part to be analyzed.

- (a) Create the main rectangular shape.  
Pre Proc > Modeling > Create > Areas > By 2 Corners  
Enter the following values
 

WPX	0
WPY	0
Width	400
Height	200
- (b) Create the Circle corresponding to the hole  
Pre Proc > Modeling > Create > Areas > Circle > Solid Circle  
Enter the values in the windows
 

WPX	200
WPY	100
Radius	10
- (c) Subtract the circle from the rectangle.  
Modeling > Operate > Boolean > Subtract > Areas  
Select first the rectangular area and then the area to be subtracted. Figure 7.25 shows the plate.

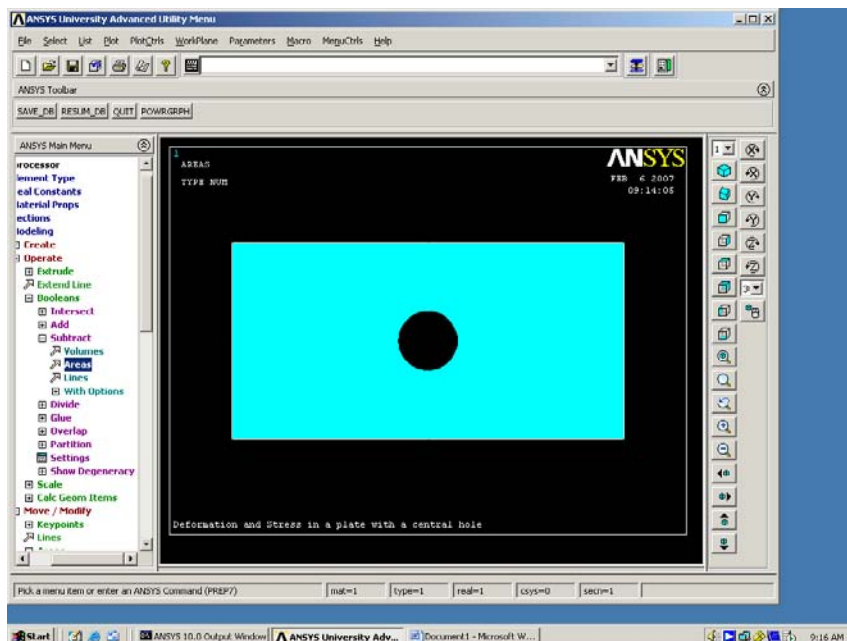


Fig. 7.25 Plot of the Plate



## ANALYSIS

## 1. Define Analysis Type

Solution > Analysis Type > New Analysis

## 2. Apply Constraints

The left edge of the plate is fixed.

Solution > Define Loads > Apply > Structural > Displacement > On Lines

Select the left edge of the plate by mouse and click on APPLY in the APPLY U, ROT on Lines window.

Select 'ALL DOF'.

Enter '0' in the displacement value field.

## 3. Apply loads

Solution > Define Loads > Apply > Structural > Pressure > On Lines

When the window appears click on the right edge.

Click on OK.

Fill in the 'Apply Pressure Field' as Constant Value.

Enter Load Pres(sure) as  $-2.5$  for 2.5 Mpa. (Please note the minus sign to signify that the pressure is acting away from the plate). Figure 7.27 shows the plate with boundary conditions.

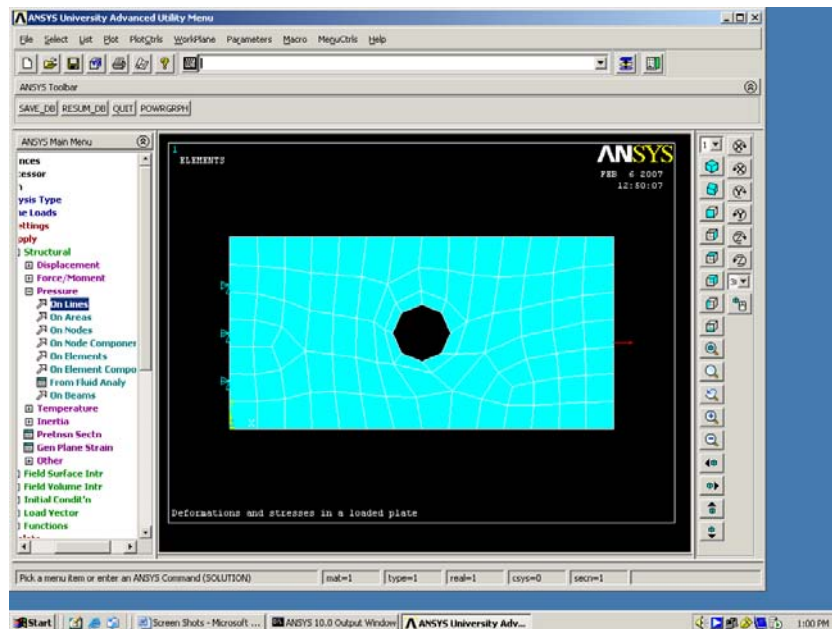


Fig. 7.27 Plate with Loads and Boundary Conditions

## 4. SOLUTION

Solution > Solve > Current LS

## 5. POST PROCESSING

1. The solution depends on the number of elements. The more the number of elements the more accurate will be the solution. Therefore it is advisable to repeat the analysis with more number of elements until the solution converges.

Utility > Plot > Nodes

List the stresses

General Post Proc > List Results > Nodal Solutions > Stress >

Principals > First Principal Stress

The nodal stresses are given in Table 7.5

**Table 7.5 POST1 Nodal Stress Listing**

<b>NODE</b>	<b>S1</b>	<b>S2</b>	<b>S3</b>	<b>SINT</b>	<b>SEQV</b>
1	40.911	7.0331	0.0000 4	0.911	37.887
2	24.957	0.0000	-0.43028E -01	25.000	24.978
4	25.947	0.0000	-2.2025	28.150	27.116
6	24.951	0.83978E-01	0.0000	24.951	24.909
8	26.001	0.0000	-0.15653	26.158	26.080
10	27.594	0.0000	-0.16351E-02	27.595	27.594
12	29.473	0.84683E-02	0.0000	29.473	29.469
14	30.928	0.75199E-01	0.0000	30.928	30.891
16	30.795	0.16510	0.0000	30.795	30.713
18	28.320	0.17534	0.0000	28.320	28.233
20	24.002	0.0000	-0.65192E-01	24.068	24.035
22	21.860	0.0000	-0.35112	22.211	22.038
24	24.162	0.0000	-0.69389E-01	24.231	24.197
26	28.572	0.20555	0.0000	28.572	28.470
28	31.183	0.18351	0.0000	31.183	31.092
30	31.479	0.84025E-01	0.0000	31.479	31.437
32	30.221	0.19984E-01	0.0000	30.221	30.211
34	28.487	0.0000	-0.64605E-02	28.493	28.490
36	26.901	0.0000	-0.26405E-01	26.927	26.914
38	25.706	0.0000	-0.26325E-01	25.732	25.719
40	25.045	0.0000	-0.28339E-01	25.073	25.059
42	24.956	0.0000	-0.42888E-01	24.999	24.978
44	24.973	0.49350E-01	0.0000	24.973	24.948
46	24.991	0.66833	0.0000	24.991	24.664
48	25.010	1.5557	0.0000	25.010	24.269
50	25.028	2.2838	0.0000	25.028	23.968

Contd....

52	25.034	2.5615	0.0000	25.034	23.857
54	25.028	2.2846	0.0000	25.028	23.968
56	25.011	1.5563	0.0000	25.011	24.270
58	24.991	0.66853	0.0000	24.991	24.664
60	24.973	0.48966E-01	0.0000	24.973	24.949
62	40.905	6.9940	0.0000	40.905	37.895
64	25.046	0.0000	-0.28421E-01	25.074	25.060
66	25.704	0.0000	-0.26220E-01	25.730	25.717
68	26.898	0.0000	-0.26078E-01	26.924	26.911
70	28.480	0.0000	-0.93036E-02	28.490	28.485
72	30.216	0.19448E-01	0.0000	30.216	30.206

The accuracy of solution depends on the number of elements used for the analysis. It is advisable to repeat the analysis by increasing the number of elements and carry out the analysis on the new model. If the difference in the results is large the mesh can be further refined. This could be repeated until the difference (error) in two successive analyses is within acceptable limits.

Now reduce the size of the elements. This could be done by decreasing the edge length.

2. Pre Proc > Meshing > size Cntrls > Manual Size > Areas >All Areas

Decrease the edge length to 20 mm.

Now re-mesh the model.

Pre Proc > Meshing > Mesh > areas >Free

3. Re-Mesh entities window will appear. Click on OK

Figure 7.28 shows the refined mesh with reduced element length.

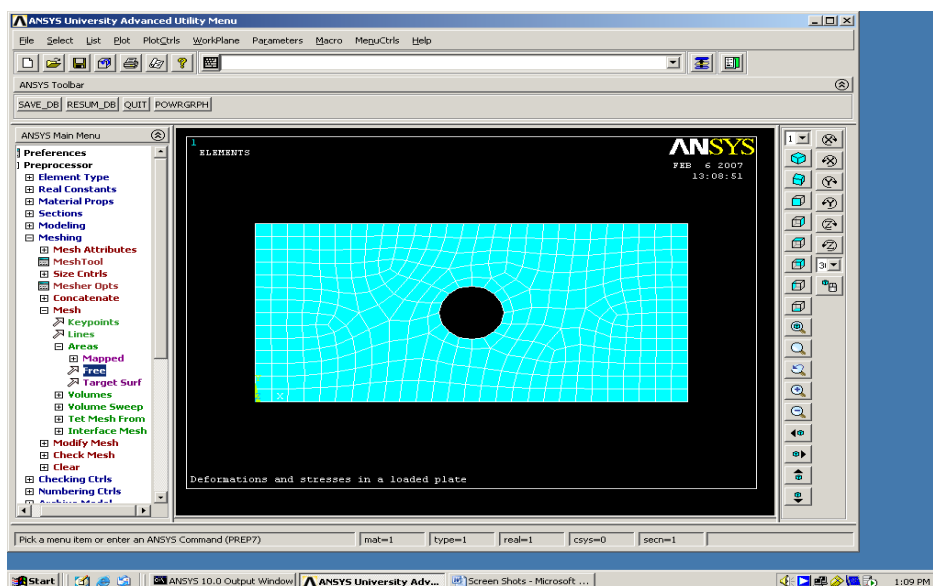


Fig. 7.28 New Model with Edge Length 20



4. Solve the system  
Solution >Current LS

**Table 7.6 Nodal Results with Mesh Edge Length of 20**

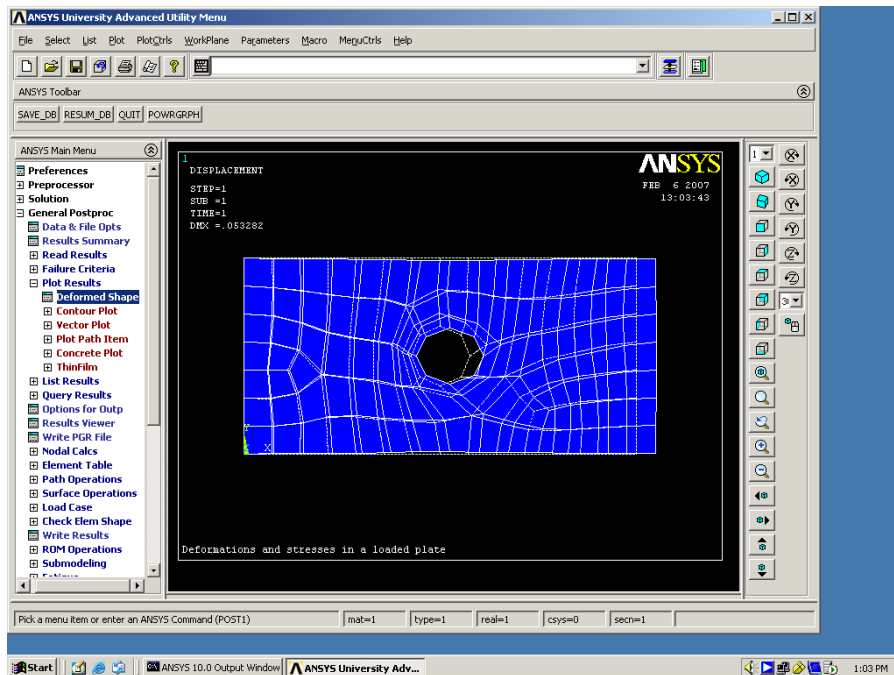
<i>NODE</i>	<i>S1</i>	<i>S2</i>	<i>S3</i>	<i>SINT</i>	<i>SEQV</i>
1	44.096	7.4882	0.0000	44.096	40.869
2	24.982	0.0000	- 0.16762E-01	24.999	24.990
4	26.811	0.0000	- 2.3658	29.176	28.068
6	24.956	0.11416	0.0000	24.956	24.899
8	25.196	0.0000	- 0.16414	25.360	25.278
10	25.929	0.0000	- 0.10017E-01	25.939	25.934
12	27.069	0.0000	- 0.26429E-01	27.095	27.082
14	28.430	0.14974E-02	0.0000	28.430	28.429
16	29.790	0.36502E-01	0.0000	29.790	29.772
18	30.823	0.86413E-01	0.0000	30.823	30.780
20	30.941	0.16254	0.0000	30.941	30.860
22	30.069	0.18366	0.0000	30.069	29.977
24	27.555	0.11748	0.0000	27.555	27.496
26	24.453	0.0000	- 0.12492	24.577	24.515
28	22.205	0.0000	- 0.24006	22.445	22.326
30	22.287	0.0000	- 0.16769	22.455	22.372
32	24.651	0.0000	- 0.26986E-01	24.678	24.664
34	27.988	0.72446E-01	0.0000	27.988	27.951
36	30.570	0.85646E-01	0.0000	30.570	30.527
38	31.686	0.68886E-01	0.0000	31.686	31.651
40	31.490	0.37784E-01	0.0000	31.490	31.471
42	30.516	0.15015E-01	0.0000	30.516	30.508
44	29.243	0.0000	- 0.14274E-03	29.244	29.243
46	27.965	0.0000	- 0.92332E-02	27.974	27.969
48	26.835	0.0000	- 0.13731E-01 2	6.848	26.841
50	25.924	0.0000	- 0.16891E-01	25.941	25.932
52	25.278	0.0000	- 0.16804E-01	25.295	25.287
54	24.977	0.0000	- 0.17537E-01	24.994	24.986
56	24.982	0.0000	- 0.16298E-01	24.998	24.990
58	24.982	0.0000	- 0.22701E-01	25.004	24.993
60	24.987	0.24936	0.0000	24.987	24.863
62	24.994	0.79296	0.0000	24.994	24.607
64	25.004	1.4354	0.0000	25.004	24.319
66	25.013	2.0212	0.0000	25.013	24.066
68	25.018	2.4263	0.0000	25.018	23.898
70	25.020	2.5711	0.0000	25.020	23.839
72	25.018	2.4269	0.0000	25.018	23.897

It can be noted that the results have changed. Repeat from 2 to 4 till the solution converges.

#### 5. Deformation

General Post Proc > Plot results > Deformation Shape >  
Def + Un-deformed

The plot (Fig. 7.29) shows both deformed and original shape.



**Fig. 7.29 Deformed Shape of the Plate**

General Post proc > Plot Results > Nodal solutions

Or

General Post proc > List Results > Nodal solutions

#### 5. STRESSES

General Post proc > Plot Results > Nodal solutions

Or

General Post proc > List Results > Nodal solutions

Typical stress contours are shown in Fig. 7.30. Design could be thus carried out for different stresses (Principal stresses, von Mises etc.)

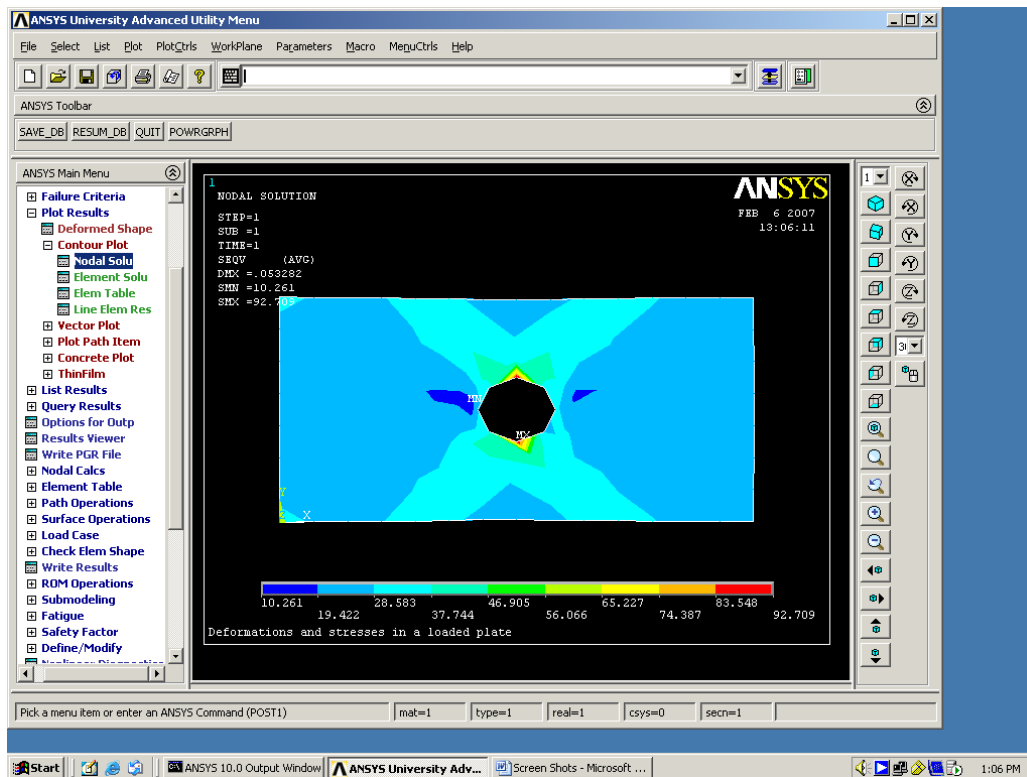


Fig. 7.30 Stress Contours

## 7.14 MANUFACTURING APPLICATIONS

Finite element technique and CFD are being widely employed in simulation of manufacturing processes like casting, welding, forming, heat treatment etc. The following sections give a brief overview of manufacturing applications of this technique.

### 7.14.1 CASTING SIMULATION

Many defects occur in castings due to bad casting design or improper methoding. Usually these defects are observed after the casting is made. Considerable time and money would have already been invested in the design, methoding and pattern manufacture. At this stage correction may entail redesign of the castings, patterns, runners or risers. The conventional prototype manufacture in foundry is thus a trial and error process and the delivery of good acceptable castings is therefore delayed. These problems can be solved by simulating the solidification of castings.

Using the simulation software, the design of castings, runners and risers can be tested for castability even before the first casting is made. The simulation will bring out hot spots and other defects pertaining to solidification and necessary corrections could be made at the design stage itself. The casting simulation thus helps to shorten the lead times, produce

high quality castings and improve the yield, resulting in lower cost, higher profits and improved market share. Sand casting, investment casting, permanent mold casting, pressure die casting and continuous casting of several materials can be analyzed using simulation. These software packages have modules to assist casting designers on proper gating and riser design. The flow of molten metal in the mold cavity can also be simulated. The thermal modeling capabilities include conduction, convection and radiation. Using simulation it is possible to minimize the defects due to improper flow of molten metal, such as misruns, premature solidification, and oxide formation as well as mold erosion due to excessive velocity of molten metal during filling.

The simulation programs also may have an optimization module based on criteria like yield, shrinkage or solidification time.

#### **7.14.2 COMPARISON BETWEEN CONVENTIONAL CASTING APPROACH AND THE SIMULATION APPROACH**

The conventional casting process is more of a sequential process. At different stages, the engineer encounters problems which make it necessary to go to previous stages for design improvement or rectification. Corrections after the pattern or die is made are more costly. More important issue is the consequent increase in the development cycle time and the associated cost overrun. In the CAE approach, the casting design and the casting process are verified through analysis and simulation before the pattern or die is made. This considerably reduces the development cycle time and costly iterations. Moreover, the customers are made happy because of on time delivery of the castings.

#### **7.14.3 CASTING DESIGN SOFTWARE**

There are several commercial casting simulation packages available. Some of them are listed below:

- ProCAST
- PASSAGE/PowerCAST
- dieCAS
- MAGMA
- Alphacast-MAVIS FLOW
- PAM-CAST
- SOLIDCAST, FLOWCAST, OPTICAST

#### **7.15 WELDING SIMULATION**

Welding involves very high temperatures to melt the metal in the weld zone whereas the metal at a short distance from the weld pool will be at room temperature. As the weld cools, the residual stresses are produced in the weld zone. These residual stresses induce distortion of the welded structure, which is a major problem the fabricating engineers would like to avoid. The prediction of residual stresses will yield a quantitative understanding of the thermal distortion. The simulation uses a sequentially coupled approach in which a thermal

analysis is followed by a stress analysis. The most important phenomenon in welding is heat conduction, which determines the thermal history of the work piece. The thermal history has a significant influence on the microstructure and work piece distortion. The convective flow of the molten metal in the weld pool is also important in this respect.

There are several software packages available to help the weld planners to determine the best approach to welding from design to fabrication. A typical simulation covers single pass welding, multi pass welding, friction welding and friction stir welding. The procedure involves modeling the configuration of the weld joint, creation of a global model consisting of the component to be joined by welding, definition of welding sequence and fixturing and finally the calculation of distortion. The analysis of distortion may help to optimize the process.

A list of welding software packages is given below:

- PAM-Assembly
- SORPAS
- Virtual Fabrication Technology (VFT)
- WELD PRO
- CRADA

## 7.16 FINITE ELEMENT ANALYSIS APPLICATIONS TO METAL FORMING

Metal forming comprises many processes like sheet metal forming (blanking, bending, drawing, stamping, deep drawing, coining, forming etc), extrusion, rolling, forging etc. Forming a sheet metal part usually involves the deformation of the material by either one or a combination of various sheet metal forming processes. Metal forming is a near net shape manufacturing process and has very wide application in many industries. In particular, sheet metal work involving stamping, drawing and forming is very important activity in automotive manufacturing. Approach to metal forming earlier was more empirical resulting in considerable trial and error, rework of part design and tooling, wastage and long cycle time in product realization, not to mention about the resultant increase in cost.

FEA based computer simulation software packages for metal forming eliminate the trial and error approach by allowing rapid modeling of the process at the blue print stage itself, resulting in the reduction of development time and quick turn around of new products. The high cost of prototyping, multiple tooling and design iterations, process variability etc can be substantially reduced, if not entirely eliminated.

Numerical simulation of metal forming operations requires highly complex and accurate mathematical formulation to model large displacements, rotations, strains and interfacial friction.

The procedure for simulation of metal forming operations involves generally the following steps:

- Creating a solid model of the component
- Developing flat patterns from the solid model in the case of sheet metal parts
- Predicting likely manufacturing defects prior to fabrication
- Optimize product designs
- Determining the most efficient manufacturing process
- Arrive at tool parameters
- Suggesting solutions for solving manufacturing problems.

There are many software packages available for metal forming simulation. Some of them are listed below:

- HyperForm
- FemForm
- AutoForm
- Fastform
- HypereXtrude
- PAM-STAMP
- DEFORM
- HyperBlank
- LS-DYNA
- OPTRIS
- Dynaform
- MSC.SuperForge
- Forge 2D, Forge 3D

### 7.17 SIMULATION OF HEAT TREATMENT

Important issue in heat treatment is the prediction of residual stresses and distortion. The heat treatment simulation requires simultaneous modeling of complex physical phenomena: heat transfer, phase transformations, changes in microstructure and mechanics. The simulation of heat treatment is very involved because of the complex nature of the constitutive behavior of the thermo-mechanical properties of the material. Considerable research is being carried out to simulate numerous heat treatment processes - case hardening, through hardening, tempering and annealing. Some software products are already available in the market. However, there is still considerable scope for development work in this domain.

### 7.18 PLASTIC INJECTION MOLDING

Plastic injection molding is one application where the finite element technique has been widely used for a long time. Mold flow, mold cool, warpage, shrinkage etc could be simulated using a mold analysis software so that the time to market could be considerably reduced in developing plastic injection molded parts.

**QUESTIONS**

1. Discuss the principle of finite element modeling and analysis for the optimized design of mechanical components.
2. Describe the general steps involved in a finite element analysis.
3. Enumerate various types of design problems that could be handled by FEA.
4. Distinguish between flexibility and stiffness methods used in FEA.
5. Identify two mechanical components each which could be modeled by spring, spar and beam elements. Justify your answer.
6. The truss shown in Fig. 7.8 is manufactured using steel L angles of  $50 \times 50 \times 10$  mm cross section. Other details remaining the same, calculate the stresses in elements 1 and 2. Verify your answer using a finite element analysis software.
7. Give some examples of plane stress and plane strain problems in machine design.
8. The steel plate shown in Fig. 7.11 has the following dimensions. Length 13 = 800 mm. Length 35 = 1250 mm. A force of 500 N acts on node 5. Develop the stiffness matrix and solve for stresses and displacements.
9. Differentiate between isoparametric and non linear elements.
10. Why is the assembly procedure of stiffness matrix attached considerable importance?
11. Discuss the following with reference to stiffness matrix:
  - i. Sparse matrix
  - ii. Band width
12. What are the capabilities of a typical general purpose FEA package?
13. Describe the step by step procedure in solving a design problem using a FEA package.
14. What are the steps involved in creating a pre processing file for the truss shown in Fig. 7.8 and the plate shown in Fig. 7.11.
15. Describe the various approaches to create a finite element model from a solid model.
16. Describe the considerations in selecting elements to model the following:
  - i. Column of a machine tool
  - ii. Connecting rod of an engine
  - iii. Spindle of a lathe
  - iv. Flywheel of a diesel engine
17. Analyze the problem given in Fig. 7.24 with different number of elements and draw a graph percentage error Vs number of elements.
18. Describe the application of finite element technique to simulate:
  - i. Sand Casting
  - ii. Die Casting
  - iii. Plastic Injection molding
  - iv. Forming

# CIM DATA BASE AND DATA BASE MANAGEMENT SYSTEMS

*In a CIM environment the total integration of operations is achieved by a common database linking various designs, manufacturing and other related activities. This chapter deals with the concepts of database and database management system suitable for computer integrated manufacturing.*

## 8.1 INTRODUCTION

As discussed in the previous sections, Computer Integrated Manufacturing integrates all the functions related to the manufacture. The following are the major functions among them:

- i. Computer aided engineering covering design, analysis, simulation and optimization.
- ii. Computer aided manufacturing
- iii. Operations Management
- iv. Logistics, Supply Chain Management, Warehousing and other functions.

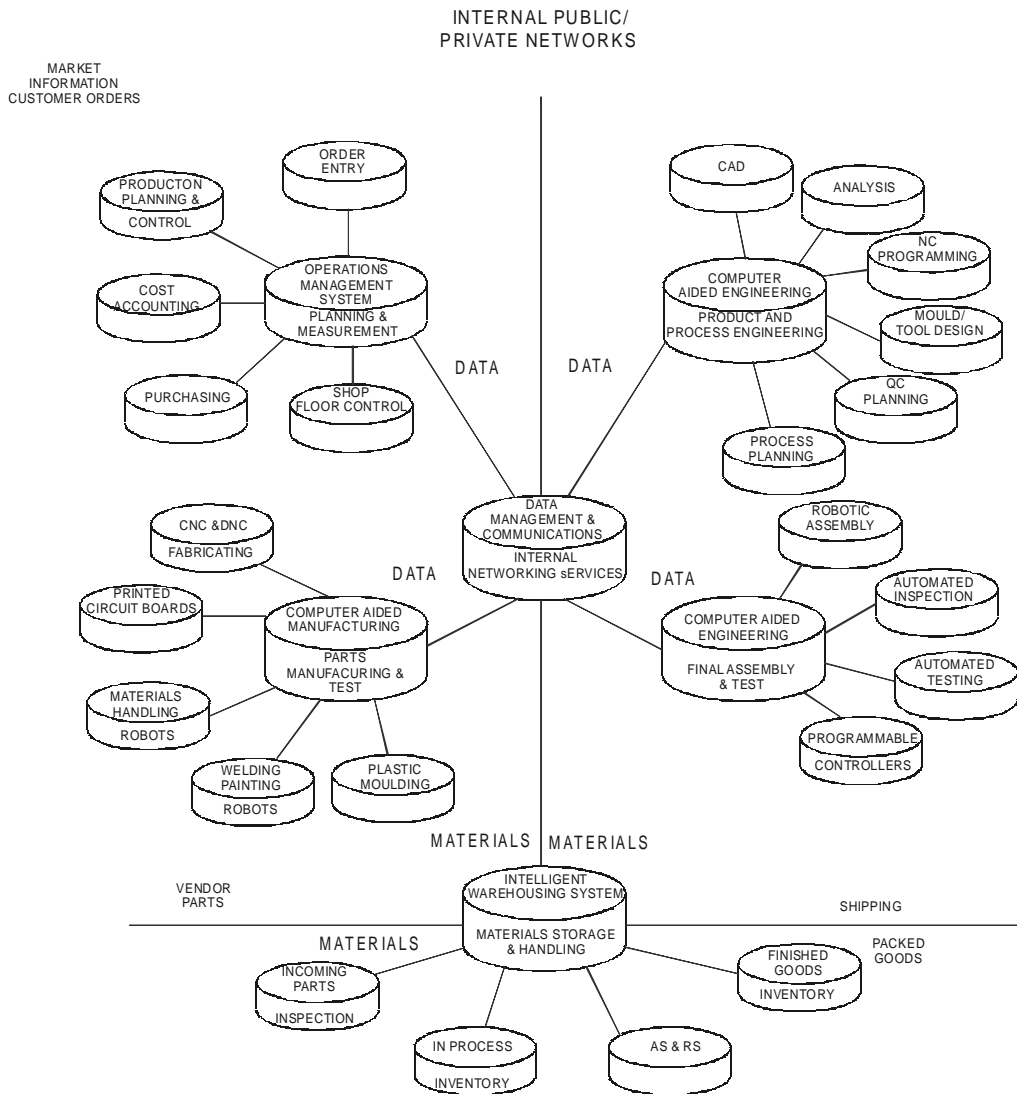
In the ideal case, all these and their related functions use the same database as shown in Fig. 8.1. In essence, the successful implementation of CIM lies in the efficient way relevant data is shared among the different segments of CIM.

The information required for manufacturing is complex covering a wide range of disciplines and serving a multitude of inter-related yet vastly differing needs. The CIM database comprises basically four classes of data:

- i. **Product Data:** Data about parts to be manufactured. It includes text and geometry data.
- ii. **Manufacturing Data:** The information as to how the parts are to be manufactured is available in production data.
- iii. **Operational Data:** Closely related to manufacturing data but describes the things specific to production, such as lot size, schedule, assembly sequence, qualification scheme etc.



- iv. **Resource Data:** This is closely related to operational data but describes the resources involved in operations, such as materials, machines, human resources and money.



**Fig. 8.1 CIM Data Base**

Product Design and Manufacturing process increasingly requires access to substantial technical information in various stages like design, analysis and manufacturing as well as smooth co-ordination among the many functions constituting an enterprise. Manufacturing organizations may waste a considerable portion of their resources due to delayed or error-prone communication from one segment to another. It would therefore be desirable to have one single central database that would contain all information.

## 8.2 DATABASE REQUIREMENTS OF CIM

A major challenge facing the implementation of CIM is to establish the type of data needed to bridge the mechanical design and manufacturing functions. Following is the list of varied tasks one might expect to accomplish in a CIM environment.

- i. Designing assemblies and performing tolerance analysis on those assemblies.
- ii. Preparing production drawings of assemblies, individual parts, tooling, fixtures and other manufacturing facilities.
- iii. Creating analytical models of parts for structural, kinematical and thermal analysis (FEM, MeM etc).
- iv. Calculating weights, volumes, centres of gravity and other mass properties and costs of manufacturing (cost estimation).
- v. Classifying existing parts according to shape, function, and the process by which they are manufactured and retrieving these parts from the parts library on demand (Group technology and coding).
- vi. Preparing part lists and bill of materials (BOM).
- vii. Preparing process plans for individual part manufacture and assembly (Variant or Generative).
- viii. Programming CNC machines for processing complete parts (CAM).
- ix. Designing work cells and programming the movement of components in those cells using work handling devices like robots, conveyors, AGV's/ RGV's, etc. (Cellular manufacture).
- x. Controlling engineering changes and maintaining associativity between design and manufacturing (PDM, VPDM, concurrent associativity etc).
- xi. Preparing programs to handle components or manipulate production equipment (like welding torches or robots).
- xii. Preparing inspection programs including programs for CNC co-ordinate measuring machines [CNC CMM's].

The exchange of graphic information has been advanced with increasing acceptance of Initial Graphics Exchange Specification (IGES) and STEP.

## 8.3 DATA BASE

A data base can be defined as a collection of data in a single location designed to be used by different programmers for a variety of applications. The term database denotes a common base of data collection designed to be used by different programmers. More specifically it is a collection of logically related data stored together in a set of files intended to serve one or more applications in an optimal fashion. Data are stored such that they are independent of the data. A database must also have a predetermined structure and organization suitable for access, interpretation, or processing either manually or automatically. A database not

only stores the data but also provides several ways to view the data depending upon the needs of the user. There are several classifications of data.

- i. **Physical data:** These are data stored in the computer's storage device. The volume of data required by a manufacturing company is so large that secondary storage devices such as hard discs, tapes, CD-ROMs, and other digital storage devices of several gigabyte capacities will be used.
- ii. **Logical data:** This indicates how a user views the physical data. The distinction between the physical data and the corresponding logical view is that the user conceptualizes certain meaningful relationships among the physical data elements. For example, we may have a set of items and quantities recorded in files. The logical view or interpretation of these sets of data can be that the items represent components available in stores and that the quantities recorded correspond to their inventory.
- iii. **Data independence:** Database management systems (DBMS) are used by the users to manage the physical data. DBMS makes a distinction between the two namely, the user and the physical data. Changes in the organization of physical data and or in the storage device parameters are absorbed by DBMS and therefore do not affect the user or more accurately, the application program. This flexibility is absent in the traditional file systems.

### 8.3.1 OBJECTIVES OF DATABASE

A database serves the following objectives:

- Reduce or eliminate redundant data
- Integrate existing data
- Provide security
- Share data among users
- Incorporate changes quickly and effectively
- Exercise effective control over data
- Simplify the method of using data
- Reduce the cost of storage and retrieval of data
- Improve accuracy and integrity of data

### 8.3.2 ISSUES OF CONCERN IN DATABASE

There are, of course, some issues to be considered while implementing a database. These include:

- High investment in hardware and software
- Need to use larger and faster hardware
- Necessity to have highly trained manpower

- Redundancy to take care of eventualities like crash of the database server.
- Need to ensure integrity and reliability of data

## 8.4 DATABASE MANAGEMENT

The manufacturing database and its management are major issues in CIM. The issues are complex but they are beginning to be addressed in a number of ways, including schemes for organizing data, standards for product data exchange and standards for communication protocols. The standards for product data exchange are discussed in chapter 17 and communication protocols have been discussed elsewhere. This chapter hence is devoted to the organization of data.

A major problem to be solved to implement CIM has always been that of distributing information among different computer based systems. As indicated in earlier chapters CIM is typically integration of islands of computer aided functions running on different computers using different databases. Joining those islands into an effective CIM enterprise requires proper methods of processing information. Information, if it is to be useful, must be appropriate, machine-interpretable, and available when and where it is needed.

## 8.5 FEATURES OF A DATABASE MANAGEMENT SYSTEM

A database management system consists of a collection of interrelated data and a set of programs to access that data. Database management involves:

- Organize a database.
- Add new data to the database.
- Sort the data in some meaningful order.
- Search the database for types of information.
- Print the data into formatted reports.
- Edit the data.
- Delete the data.

### 8.5.1 DATABASE ADMINISTRATOR

The person responsible for managing the database is often referred to as database administrator. His functions include:

- Creating the primary database structure
- Backing up and restoring data in case of crash
- Modifying the structure
- Transfer data to external files
- Allocate and control user access rights
- Monitoring performance

### 8.5.2 COMPARISON OF DATABASE AND TRADITIONAL FILE SYSTEMS

File system represents a tight coupling between physical data and user's program. They lack almost all the flexibilities offered by DBMS. Most of the indispensable facilities of DBMS are, therefore, forced to be absorbed by user's program. In other words besides the logic of the application the user has to provide logic for constructing the logical view of data, has to interpret the operations on the logical view and translate them in to the primitive file operations, and has to be responsible for maintaining the files that store the physical data. The tight coupling and interdependence of between a user's application and the physical data would not allow sharing of the same data by other applications that may need to view and manipulate them differently. This then forces the data to be duplicated among various applications. File systems lack dynamism in the sense that the application programs are designed, coded, debugged, and catalogued ahead of time for the preconceived requests and applications.

The following list summarizes the problems of file systems that can be overcome by DBMS.

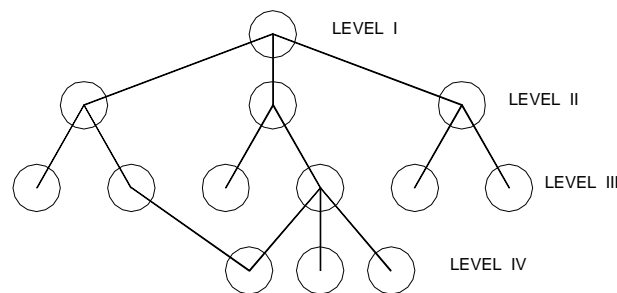
- i. Data dependence
- ii. Rigidity
- iii. Static nature
- iv. Lack of integration
- v. Data duplication
- vi. Inconsistency
- vii. Difficulty in sharing information
- viii. Inefficiency
- ix. Inability to handle adhoc requests.

## 8.6 DATABASE MODELS

There are three ways in which data can be organized: hierarchical, network or relational.

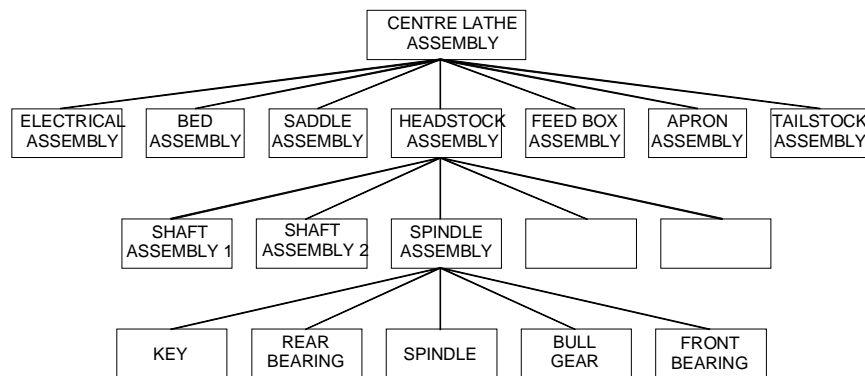
### 8.6.1 HIERARCHICAL DATABASE

Fig 8.2 shows a typical hierarchical file structure. The nodes in level 2 are the children of node at level 1. The nodes at level 2 in turn become parents of nodes in level 3 and so on.



**Fig. 8.2 A Typical Hierarchical File Structure**

In a hierarchical model, data files are arranged in a tree like structure which facilitates searches along branch lines; records are subordinated to other records at a higher level. Starting at the root of the tree, each file has a one-to-many relationship to its branches. A parent file can have several children. A good example of such an organization might be a parts list, in which each product is composed of assemblies which are in turn composed of sub assemblies and/or component parts. As an example of hierarchical database structure, the parts list of lathe assembly is shown in Fig 8.3. Examples of hierarchical database management systems are IMS and SYSTEM 2000.



**Fig. 8.3 Parts of a Lathe Assembly**

**8.6.2 NETWORK DATABASE**

The network database is a combination of several hierarchies in which child files can have more than one parent file, thereby establishing a many-to-many relationship among data. A hierarchical model is actually a subset of a network model. Examples of network database languages are TOTAL and IDMS.

In both hierarchical and network databases data relationships are predefined and embedded in the structure of the database. Access to data is processed by associated application programs. A limitation of both hierarchical and network systems is the restriction they place on data access. They both require that the rules of data access be defined when the data structure is defined. The access rules are difficult to modify after the database has been implemented. They are suited for batch operations that are highly structured and repetitive involving high transaction rates.

**8.6.3 RELATIONAL DATABASE MANAGEMENT SYSTEMS (RDBMS)**

Data is organized in the form of a table for a large variety of manufacturing applications. An example of such a set of data is given in Table 8.1.

**Table 8.1 Dimensions for Deep Groove Ball Bearings**

<b>No.</b>	<b>D</b>	<b>D1</b>	<b>D</b>	<b>D2</b>	<b>B</b>	<b>r</b>	<b>r1</b>
6403	17	26	62	53	17	2	1
6404	20	20	72	63	19	2	1
6405	25	36	0.00	69	21	2	1
6403	17	26	62	53	17	2	1

There is a correspondence between the concept of a table and the mathematical concept of a relation. In a RDBMS (Relational Database Management System) an entity is an object that is distinguishable from other objects. An entity set is a set of entities of the same type and is represented by a set of attributes. For each attribute there is a set of permitted values for domains. An entity relationship model (E-R Model) is based on the perception of the real world which consists of a set of entities and relationships among them.

Process planning is a good example of such an interactive need to evaluate many data relationships in order to arrive at a logical sequence of properly defined manufacturing steps.

The relational database eliminates the need to follow predefined access paths to reach target data, and makes data access more flexible. The database user gains quicker access to information since the database provides direct access to all data. The access is independent of the way it is stored. The RDBMS is also flexible. Hence relational database facilitates unanticipated queries and makes it well suited to the manufacturing environment. Several vendors now offer relational database management systems, suitable for CIM applications.

***Features of RDBMS include:***

- Adhoc or unanticipated queries. This is typical in a manufacturing environment.
- Relational database is dynamic. The relationships change and are extended frequently in a manufacturing database.
- Suitable where enterprise information has to be available to a large number of users for decision making.
- Desirable where application specifications, development and maintenance costs are to be kept at the minimum level.
- Compatible with distributed databases.

***Some of the important features of RDBMS are given below:***

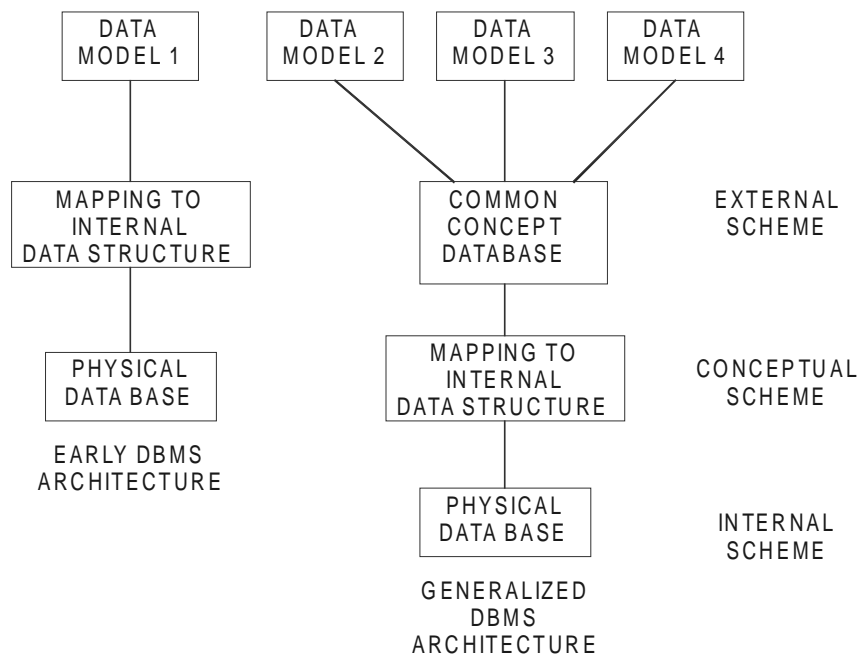
- i. Guaranteed logical accessibility.
- ii. Dynamic on-line catalogue.
- iii. Comprehensive data sublanguage.
- iv. Views that could be modified depending on need.
- v. High-level insert updates and delete.

- vi. Physical data independence.
- vii. Logical data independence.
- viii. Integrity independence.
- ix. Distribution independence.

### 8.7 DBMS ARCHITECTURE

Fig. 8.4 shows a typical RDBMS architecture. In this architecture, multiple models are derived from a single conceptual data model. It has more abstraction capability. This is also referred to as the syntactic or operational data model meaning that it is more syntactically driven and is a vehicle of user’s manipulations.

There are several levels of abstraction in data modeling. These influence the RDBMS architecture. The architecture of Fig. 8.4 has multiple levels, which is a price to be paid for flexibility.



**Fig. 8.4 RDBMS Architecture**

### 8.8 QUERY LANGUAGE

It was mentioned earlier that queries are used to access databases. A query language is one with which a user requests information from a database. Two categories of query languages are:



- (i) Procedural
- (ii) Non-procedural

There are a number of commercial query languages available today. They can be classified as:

- SQL - Structured Query Language
- QUEL - Query Language
- QBE - Query by Example

The structured query language approach is widely used. The following section presents a brief overview of SQL.

### 8.9 STRUCTURED QUERY LANGUAGE [SQL]

The advent and successful implementation of relational databases has brought with it need for a data base language that is user friendly enough for the common user while being convenient and comfortable for the programmer and applications builder. The structured query language now called SQL [pronounced "sequel"], has emerged to fill this need. The user can easily learn and understand SQL. It can be embedded in a procedural language such as C, COBOL, or PL/I. SQL helps user and programmer to understand the requirements of each other. This fact is very important in making the transition from paper files to computerized database systems smooth.

SQL is acronym for Structured Query Language. It is often referred to frequently by its former name, Sequel.

The basic structure of an SQL expression consists of three clauses: select, from and where.

The static clause corresponds to the projection operation of the relational algebra. It is used to list the attributes desired in the result of a query.

The italic clause is a list of relations to be scanned in the execution of the expression.

The italic clause corresponds to the selection predicate involving attributes of the relations that appear in the 'from' clause.

A typical SQL query has the form

```
Select A1, A2 ... An  
From r1, r2 ... rm  
Where P.
```

The A's represent attributes, the r's represent relations, and the P is a predicate.

SQL forms certain product of the relations named in the 'from' clause, performs a relational algebra selection using the where clause predicate.

**Examples:**

- (i) Select       Cutting speed  
    From        cut-data  
    Where       Material = "C45"  
    And         cutting = "Rough turning"  
    And         tool = "Carbide"
- (ii) Select     Feed per tooth  
    From        Mill-data  
    Where       Material = "Aluminum"  
    And         Process = "End Milling"  
    And         Cutting = "Rough"

A number of commercial databases now incorporate SQL as their data sub language.

- i. IBM System R
- ii. The Information Management Systems (IMS)
- iii. The SQL/Data System (SQL/DS)
- iv. Database 2(DB2)
- v. ORACLE
- vi. Informix
- vii. SQLBASE XDB
- viii. Ingres
- ix. Sybase
- x. Progress

**8.10 SQL AS A KNOWLEDGE BASE QUERY LANGUAGE**

Artificial Intelligence (AI) has wide applications in CIM. Expert Systems constitute an important field of AI. These systems require extensive knowledge bases to enable sound decision making. A knowledge base is a database and a set of rules. As such, a knowledge base is used in the construction of an expert system, which emulates the reasoning of a human being in some field of knowledge.

In an expert system, exact answers to the queries posed to the knowledge base are not necessarily contained within the system. The rules for obtaining an answer provide a means for arriving at a conclusion. The conclusion may not necessarily be an absolute answer with 100 percent certainty. It should have about the same probability of being correct as would an expert in that field. This contrasts with a database where direct answers to queries are either contained within the system or are not there at all.

SQL can be used equally well with a database or a knowledge base, and several expert systems currently exist that use SQL. Like databases, knowledge bases need to be updated

from time to time; additional data need to be inserted, as well obsolete or redundant data to be deleted. The SQL capabilities serve these purposes. However, knowledge bases have an additional problem in that rules that are added may contradict existing rules. Also, added rules may simply be extensions or necessary corollaries of existing rules, and therefore may be redundant. Testing for these problems quickly becomes tedious as the knowledge base grows large. The expert system called ARITY, developed and sold by Arity Corporation, is an example of the use of SQL to access a knowledge base.

### 8.11 PRODUCT DATA MANAGEMENT (PDM)

Databases are one component needed to deliver instant, accurate data. Engineering information systems are the other. An engineering data management system should automatically notify members of the design team with updates and circulate latest change orders. In order to derive maximum benefit from CAD it must be possible to deliver CAD data efficiently and seamlessly to all downstream applications related to engineering planning. Product data management is a technology developed to meet this need. PDM systems work on network layouts called client-server architectures. The server is also called a vault, even though the information may be distributed over several workstations. The vault acts as the heart of an engineering network. The vault or the server has the capabilities to handle efficiently large amounts of complex information. Product development engineers access the vault through their desktop computers called clients.

This client-server idea works efficiently because it runs on two separate, synchronized databases. One database stores product information such as CAD drawings, part specifications, analysis data, and manufacturing product information. The other database, called a meta database is a relational database that stores information about the data. For example given a drawing number this gives information about the attributes of the drawing i.e. where a drawing is stored and when it was last updated etc. The client software lets the clients talk to the server, allowing design engineers, manufacturing engineers, and manager's access to the information stored.

#### ***The features of a PDM system include:***

- Electronically track, access, sort and retrieve design data enabling the engineers to work on the most recently updated designs.
- Integrating the design environment by providing facilities for viewing drawings created in different CAD systems like AutoCAD, PRO/E, Unigraphics, CADD5, I-DEAS, Solid Edge, Solid Works etc.
- Providing a CAD view-and-mark up package to view complete designs on the screens of the clients so that planning engineers can satisfy themselves that designs are complete before they are released to manufacturing planning.
- Retrieving drawings and designs based on limited information so that design engineers can retrieve already available designs, thereby saving valuable time in product development.

- Capturing design revision information from a variety of documents like drawings, part lists, bill-of-materials (BOM).
- Providing data security through multi-tier access control.
- Creating comprehensive back-up and recovery procedures.
- Automatic disk clean-up of old drawing versions and batch back-up.
- Generating audit trails such as who designed the part, who modified the part, who approved the design etc.
- Providing graphical user interface tool kits so as to enable the design team to create new applications.

In short PDM is an excellent tool for concurrent engineering. PDM systems efficiently manages design reviews by getting the right documents and the drawings to the right people in the quickly. Some of the functions of PDM are discussed in the subsequent sections.

#### **8.11.1 DESIGN REVIEW FUNCTION**

To set up the design review function the project administrator defines each design project, assign the members to the team, describe the actual process and define the workflow. For example, in the case of an electric motor design project the tasks to be included may be conceptual design, stress and field analysis, detailed drawings and a description of manufacturing and assembly process. One task, for example, the design analysis will be carried out by a group of three and approved by one. The design may have to be accepted by all the members of the group. The design review system gives considerable flexibility for the persons in charge of the project.

#### **8.11.2 CHANGE MANAGEMENT**

The project administrator develops the process that handles engineering change orders. A significant change management feature is the protection of engineering changes-in-progress from implemented too soon or by accident. This also eliminates paper work.

#### **8.11.3 WHERE-USED REPORTS**

This is another function of PDM. The software answers the question, "Which assembly uses component A?". PDM produces a report which shows component-by-component breakdown of the complete assembly with the "where-used" components highlighted.

#### **8.11.4 CONFIGURATION MANAGEMENT**

The configuration management function is also called product-structure management. This shows how the parts in an assembly relate to one another. This provides an opportunity for the product administrators to create standards for handling bill-of-material part relationships and for defining product life-cycle data requirements. For example, the graphic display from a configuration management application will show the hierarchy of

automobile body parts, starting with body, doors, wheels and tyres. This will be further broken down to the last nut and bolt. Each component will be described in several ways to show the use and assembly inter-relationships.

## 8.12 ADVANTAGES OF PDM

PDM offers several benefits for the speedy execution of product development projects:

- PDM helps engineers to access design drawings in minutes.
- Managers know how many drawings were released for fabrication.
- Manufacturing engineers know exactly when to start fabrication.
- Two designers cannot simultaneously edit the same drawing.
- Two drawings cannot have the same drawing numbers.
- All information from drawing-release statistics to revision details pass to the primary project management system that tracks overall project status for all the company activities.
- The PDM system keeps a complete history of the modifications, when the modifications took place and keeps all previous versions of data for a period defined by the company.
- Subcontractors can be given direct access to PDM database. Controls ensure that no subcontractor can access data associated with the sub-sets of projects he is not involved with.

## QUESTIONS

1. Prepare a chart showing the data required and data generated in the various segments of a manufacturing industry?
2. What is a database?
3. What are the objectives of a database?
4. What are the disadvantages of a database?
5. How does the conventional file system differ from a database?
6. What are the four classes of data in manufacturing?
7. What are the desirable features of a database management system?
8. Describe the three database models.
9. Study typical data in a factory and analyze how you can classify the data.
10. What is a relational database? Give an example.
11. Describe the architecture of a database management system?
12. What are the essential requirements of a relational database management system?
13. What is a query language? What are the major types of query language?
14. What is SQL?

15. Give an example of the use of SQL to access a database?
16. What is the role of PDM in drawing office management?
17. What are the features of PDM which help speedy product development?
18. What are the benefits of PDM?

**This page  
intentionally left  
blank**

# COMPUTER AIDED PROCESS PLANNING

*Once the design of a component is over, the planning phase of manufacturing commences. The first task in planning is the design of the processes. Process planning is a vital link between design and manufacturing functions. This is an important task as the cost of the part depends on the process. One of the active research areas in CIM is computer aided process planning. This chapter deals with the use of computers for process design.*

## 9.1 INTRODUCTION

Process planning is concerned with determining the sequence of individual manufacturing operations needed to produce a given part or product. The resulting operation sequence is documented on a form typically referred to as operation sheet. The operation sheet is a listing of the production operations and associated machine tools for a work part or assembly. Process planning is an important stage of product development since production tooling like jigs, fixtures, special tools etc. can be designed only after the process is finalized.

Like a group technology - based system utilizing classification and coding to retrieve parts, code numbers can be used for retrieval of existing and preferred manufacturing information. The principle of group technology is therefore discussed here as part of process planning. The importance of process planning lies in the fact that process plans have a direct bearing on the cost of the part. As new manufacturing processes and machines are introduced, process plans also undergo changes. Hence process planning is a dynamic activity. The continuous emphasis on cost reduction also requires the process plans to be updated to reduce the cost. Cost information can be included in a computer assisted process planning system, using an automatic time standards (ATS) system.

## 9.2 PROCESS PLANNING

Manufacturing planning, process planning, material processing, process engineering and machine routing are a few titles given to the topic referred to here as process planning.



Process planning is that function within a manufacturing facility that establishes which machining process and process parameters are to be used to convert a work material (blank) from its initial form (raw material) to a final form defined by an engineering drawing. Process planning is a common task in small batch, discrete parts metal working industries. The process planning activity can be divided into the following steps:

- Selection of processes and tools
- Selection of machine tools/Manufacturing equipment
- Sequencing the operations
- Grouping of operations
- Selection of work piece holding devices and datum surfaces (set ups)
- Selection of inspection instruments
- Determination of production tolerances
- Determination of the proper cutting conditions
- Determination of the cutting times and non-machining times (setting time, inspection time) for each operation
- Editing the process sheets.

All the information determined by the process planning function is recorded on a sheet called process plan. The process plan is frequently called an operation sheet, route sheet or operation planning sheet. This provides the instructions for the production of the part. It contains the operation sequence, processes, process parameters and machine tools used. Fig 9.1 shows a typical process planning sheet.

**XYZ GLOBAL MANUFACTURING LTD. VELLORE 632014**

**PART NUMBER : 610 415 3426**

**MATERIAL: FG 200**

**PART NAME : PIN**

<i>Process Number</i>	<i>Process Details</i>	<i>Machine</i>	<i>Tool Tip Tool holder</i>	<i>Cutting Speed m/min</i>	<i>Spindle Speed rpm</i>	<i>Feed/ Feed Rate</i>	<i>Set Up Time min</i>	<i>Process Time min</i>
01	HOC CC Drill	CNC LATHE						
02	Drill	CNC LATHE						
03	Face & Turn	CNC LATHE						

*Contd...*

04	Grooving	CNC LATHE						
05	HOC	CNC LATHE						
06	HOC	CNC GRINDER						

HOC: HOLD ON CHUCK

CC : CENTRE DRILL

**Fig. 9.1 Typical Process Planning Sheet**

In conventional production system, a process plan is created by a process planner. It requires a significant amount of time and expertise to determine an optimal routing for each new part design. However, individual engineers will have their own opinions about what constitutes the best routing. Accordingly there are differences among the operation sequences developed by various planners. Efficient process planning requires the service of experienced process planners.

Because of the problems encountered with manual process planning, attempts have been made in recent years to capture the logic, judgment and experience required for this important function and incorporates them into computer programmes. Based on the features of a given part, the program automatically generates the sequence of manufacturing operations. The process planning software provides the opportunity to generate production routings which are rational, consistent and perhaps even optimal. It has the following advantages:

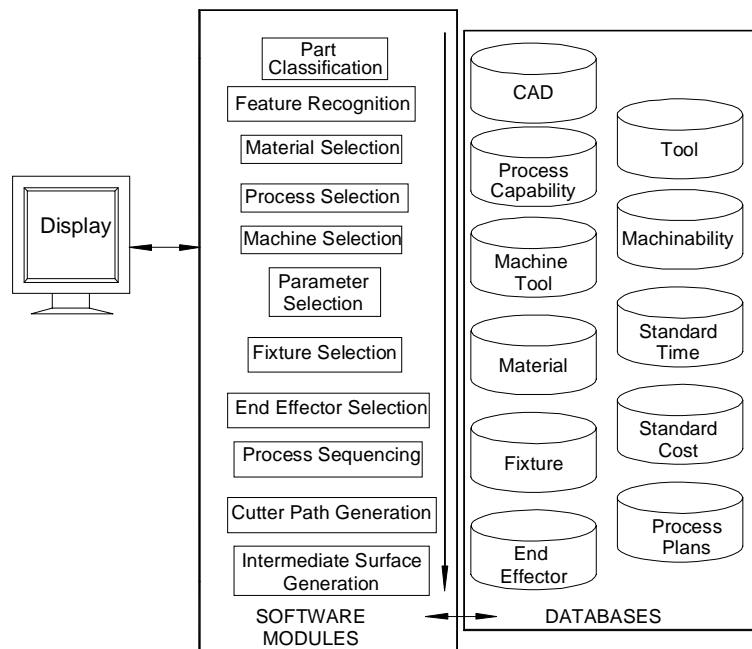
- i. Reduces the skill required of a planner.
- ii. Reduces the process planning time.
- iii. Reduces the process planning and manufacturing cost.
- iv. Creates more consistent plans.
- v. Produces more accurate plans.
- vi. Increases productivity.

The current approaches for computer aided process planning can be classified into two groups:

- i. Variant
- ii. Generative

### 9.3 STRUCTURE OF A PROCESS PLANNING SOFTWARE

Fig. 9.2 represents the structure of a computer aided process planning system. In Fig. 9.2 the modules are not necessarily arranged in the proper sequence but can be based on importance or decision sequence. Each module may require execution several times in order to obtain the optimum process plan. The input to the system will most probably be a solid model from a CAD data base or a 2-D model. The process plan after generation and validation can then be routed directly to the production planning system and production control system.



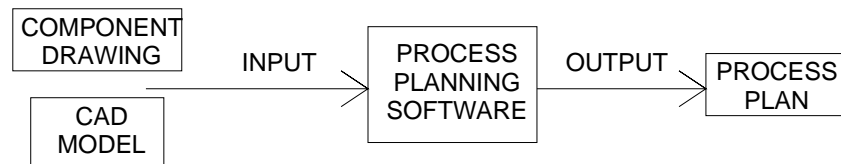
*Fig. 9.2 Structure of a Computer Aided Process Planning System*

### 9.4 INFORMATION REQUIRED FOR PROCESS PLANNING

The geometric model of the part is the input for the process planning system. The system outputs the process plan (Fig. 9.3). The input to the process planning system may be engineering drawing or CAD model. The other prerequisites for process planning are given below:

- Parts list
- Annual demand/batch size
- Accuracy and surface finish requirement (CAD Database)
- Equipment details (Work centre Database)

- Data on cutting fluids, tools, jigs & fixtures, gauges
- Standard stock sizes
- Machining data, data on handling and setup



**Fig. 9.3 Activities in Process Planning**

In a computerized process planning system a formal structure and a knowledge database are required in order to transform the engineering design information into the process definition. A brief description of the operation of a computer aided process planning software is given in the following section.

## 9.5 OPERATION OF A TYPICAL COMPUTER AIDED PROCESS PLANNING SOFTWARE

A typical process planning software may provide the following basic functions:

- i. Process planning
- ii. Initialization function
- iii. Report generation

Brief descriptions of these functions are given below.

### 9.5.1 PROCESS PLANNING

The structure of a process planning module will include modules to:

- Create a new plan
- Retrieve a plan and edit
- Delete a plan
- Display plan on monitor
- List summary information

### 9.5.2 CREATING A NEW PLAN

Creation of a new plan involves several stages. Fig. 9.4 shows the header of a typical process plan format. The user has to enter various data as per the above format. The manufacturing sequence is entered in a suitable format. A typical format is given in Table 9.1. The process plan gives each operation to be performed in sequence. The example given is for turning and drilling a workpiece. The machine, tool and the technology parameters are specified

in the process plan. Some process plans will also give the inspection tool details, jigs and fixtures to be used and will have a column for remarks, which may contain some instructions to the operator.

PART NUMBER	XYZ	
DRAWING NUMBER	MANUFACTURING COMPANY	
REV. NUMBER	Note:	
IGES/STEP FILE No:	Classification Code	Material:
PLAN REV. No:	Quantity:	Standard Plan ID
MACHINING TIME	Unit Cost:	

**Fig 9.4 Format of Header for Process Plan**

**Table 9.1 Format of Manufacturing Sequence**

<b>Serial Number</b>	<b>Machine</b>	<b>Operation Description/ Assembly Operations</b>	<b>Set Up Time</b>	<b>Production Time</b>	<b>Tool</b>	<b>Cutting Speed m/min</b>	<b>Feed/ Feed rate</b>	<b>rpm</b>	<b>Number of cuts/ Passes</b>
04	CNC Lathe	Turning	-	2	P40	240	0.5mm/ rev.	1400	4
05	"	Drilling	-	0.2	BW Drill	200	0.2mm/ rev.	2200	1

The process planning software provides some standard strings that are to be used when describing operations. Some examples are given below:

- i. Hold between centres
- ii. Rough turn xxxx dia. stock to xxxx dia.. for entire length of part
- iii. Rough turn xxxx dia. to xxxx dia..
- iv. Finish turn xxxx dia. to xxxx dia.
- v. Finish face xxxx dia. and chamfer

By selecting various strings, the operations can be entered in the operation description.

### 9.5.3 RETRIEVAL OF PLANS

A process plan can be retrieved using any of the data fields contained in its header. A single field or a combination of fields may be necessary. Some times if we know a word in the description of the part (NOTE) the process planning systems may come up with the

plan numbers or related parts. For example if we are looking for gearbox parts, by searching notes we may get:

<i>Serial Number</i>	<i>Part Number</i>	<i>Part Description</i>
1	600-01-001	Input Shaft
2	600-01-002	Drive Input Gear
3	600-01-003	Input Pulley
4	600-01-004	Key

If the user wants to retrieve the plan for Sl. No. 1 he/she can type 1 and get the plan.

#### 9.5.4 SUMMARY INFORMATION

Summary information will include Account information, Machine information, Material information etc.

Process planning software will have several modules. One such module is the automatic time standards system. Time standards are based on cutting conditions used and therefore calculation of machining time requires selection of cutting parameters. Typical input data for such a system is:

Material : C45  
 Material hardness : 220 BHN  
 Work Centre Number : L 120

The module then goes through the operation description looking for a work element (say, a machining operation). It then displays available tool materials:

- i. Coated Carbide
- ii. Ceramic
- iii. Cubic Boron Nitride
- iv. Diamond coated tools

From the operation description, pertinent dimensions will be retrieved (like starting diameter, finish diameter, cut length and depth of cut).

It also calculates number of passes, displays recommended values of depths, spindle speeds, power required and machining time. These data can be edited manually if necessary.

Similarly there may be modules for time calculation for loading and unloading. Facilities for archiving the plan are also incorporated in a process planning software.

#### 9.5.6 REPORT GENERATION

Computer aided process planning (CAPP) software packages have normally SQL capabilities incorporated. Reports can be compiled for:

- i. Parts with identical classification
- ii. Parts using specific machine type
- iii. Parts machined using specific tool materials
- iv. Bill of materials

## 9.6 CAD BASED PROCESS PLANNING - CERTAIN LIMITATIONS AND PROBLEMS

The geometric model of an object is represented by a set of data. The data consists of numerical values, names, codes and symbols. The data are stored in computer memory in an organized manner. This organization represents the relationship of each data element to other elements. Included in this relationship is the topological relationship of the surface geometry.

The common methods of geometric modeling in use today are:

- i. 2-D modeling
- ii. Surface modeling
- iii. Solid modeling

The techniques of these methods have been discussed in earlier chapters. The creation of process for CNC machining is discussed in Chapter 12. This chapter concentrates on general process design.

With the taxonomy of graphical representation described by above procedures, some general problems of part representation systems can be identified. These problems include:

- i. The inability to represent special manufacturing techniques like coatings and surface treatment.
- ii. Lack of data interchange between some drafting representations. Since there is no easy way to identify surfaces requiring machining using any of the geometric representations mentioned previously, the best solution is to use a human-computer interactive system to identify the surface.

In order to use a CAD system as the front end for computer aided process planning, the following capabilities are required.

- i. Location and interactive identification of lines and surfaces.
- ii. Easy dimension retrieval.
- iii. Storage and retrieval of tolerance information.
- iv. Capability of displaying multiple objects.
- v. Built- in special tags (i.e., drill angle for hole).
- vi. Combining information on special processes like heat treatment, surface treatment and surface finishing techniques with the geometric model.

The addition of automatic feature recognition (AFR) software has made the process planning task considerably easy. CAD software which incorporates this feature highlights

individual machining feature one by one. The process planner can then interactively define the processes or check if any feature has been left out while creating an automatic process plan.

The recent developments in modeling technologies and detailing procedures have helped designers to incorporate auxiliary information like geometric tolerances. These additions have improved the quality of process plans created by CAPP.

In the case of precision components, the process design can be extremely complex. This is particularly so when we consider components with accuracies of the order of a few micrometers and surface finishes at sub micrometer level. Further, the need to achieve the required concentricity, parallelism and perpendicularity etc. requires very careful design of the processes. Such extra precision components will have high rejection levels. Process design even by experienced planners may have to undergo several modifications to realize the ultimate product. The inability to model the dynamics of machine tool - material - work piece - fixture system is still a major bottleneck in manufacturing. Further, the physical and metallurgical behavior of the work material and the non-deterministic nature of tool wear may necessitate modifications to process plans. Tolerance accumulation in machined components is another major problem.

One of the convenient ways in which process plans can be created for a component is by searching for the availability of similar components in the component database. The similarity can be in geometry, tolerances, materials and processes. If a similar component is available it is likely that their manufacturing process is also proven. In that case it is reasonable to use the process plan with whatever modifications that may be necessary rather than creating a new process plan. Automatic process planning tends to be more successful if such a "variant" approach is adopted. This requires an efficient method of retrieval based on a suitable identification number. Codes based on group technology provide unique identification for part families. Group technology is known and practiced for the last three decades or more in batch manufacturing industries and it is a convenient tool for classifying and coding components, machined components, components made of sheet metal etc. The following sections give a brief introduction to this technology and its uses in CAPP.

Both geometric modeling and drafting are detailed representation of an engineering design. They provide information concerning the component to be made, and are essential in conveying the design intent to the manufacturing personnel.

However, as with many decision making processes, too much information may make arriving at decisions difficult. Thus, for the purpose of process plan retrieval, the group technology technique can be used to code a component without considering its finer details.

There are two types of information that are required by a process planning system:

- i. Design features of the component.
- ii. Process knowledge/economic alternatives/information of materials/process equipment.



## 9.7 GROUP TECHNOLOGY

Group technology is an operations management philosophy based on the recognition that similarities occur in the design and manufacture of discrete parts. Similar parts can then be arranged into part families. To implement such a system, some form of classification of parts and coding is required.

Part classification and coding is concerned with identifying the similarities and using these similarities to evolve a classification code. Similarities are of two types: design attributes (such as geometric shape and size), and manufacturing attributes (the sequence of processing steps required to make the part).

In companies which employ several design engineers and manufacturing a diverse range of products, such classifications and coding has a number of other uses. One of the major benefits is avoiding the duplication of similar components. This can result in considerable savings in terms of design cost, processing cost and tooling cost. One prime necessity to realize this is to have a good design retrieval system.

The parts classification and coding is required in a design retrieval system, and in computer aided process planning the process routing is developed by recognizing the specific attributes of the part and relating these attributes to the corresponding manufacturing operations.

### 9.7.1 PART FAMILIES

A part family is a collection of parts which are similar either because of geometry and size or because similar processing steps are required in their manufacture. The parts within a family are different, but their similarities are close enough to merit their identification as members of the part family. The major obstacle in changing over to group technology from a traditional production shop is the problem of grouping parts into families. There are three general methods for solving this problem.

- i. Visual inspection
- ii. Production flow analysis
- iii. Parts classification and coding system

What is desirable in a computer integrated manufacturing environment is a software which will analyze the geometric model of the part and come out with a set of alphabetic/numeric characters which can broadly embed similarities.

### 9.7.2 PARTS CLASSIFICATION AND CODING SYSTEMS

Parts classification and coding systems can be grouped into three general types:

- i. Systems based on design attributes
- ii. Systems based on part manufacturing attributes
- iii. Systems based on both design and manufacturing attributes

Systems in the first category are useful for design retrieval and to promote design standardization. Systems in the second category are used for computer-aided process planning, tool design, and other production related functions. The third category represents an attempt to combine the functions and advantages of the other two systems into a single classification scheme. The types of design and manufacturing attributes typically included in classification schemes are listed below:

***Part Design Attributes***

- Basic (External/Internal) shape
- Axisymmetric/Prismatic/sheet metal
- Length/diameter ratio
- Material
- Major dimensions
- Minor dimensions
- Tolerances
- Surface finish

***Part Manufacturing Attributes***

- Major process of manufacture
- Surface treatments/coatings
- Machine tool/processing equipment
- Cutting tools
- Operation sequence
- Production time
- Batch quantity
- Production rate
- Fixtures needed

If we take a look at a machine tool manufacturing industry, large part families can be grouped as:

- i. Heavy parts - beds, columns etc.
- ii. Shafts, characterized by large L/D ratios
- iii. Spindles (long shafts, screw rods included)
- iv. Non-rounds (small prismatic parts)
- v. Gears, disc type parts (whose L/D ratios are small)

From the manufacturing point of view, group technology can bring in considerable economy in tooling, set up time, part changeover times, machine specifications etc. The classification of components in groups can lead to formation of cells where similar components are machined. However, these considerations are extraneous to the process planning function.

## 9.8 CODING STRUCTURES

A part coding scheme consists of symbols that identify the part's design and/or manufacturing attributes. The symbols in the code can be all numeric, all alphabetic, or a combination of both types. There are three basic code structures used in group technology applications:

- i. Hierarchical structure
- ii. Chain type structure
- iii. Hybrid structure which is a combination of the above two

With the hierarchical structure, the interpretation of each succeeding symbol depends on the value of the preceding symbols. In the chain type structure, the interpretation of each symbol in the sequence is fixed and does not depend on the value of preceding digits. Most of the commercial parts coding systems are used in industry are a combination of the two pure structures.

When selecting a coding system for a component's representation, there are several factors to be considered. They include:

- i. The geometry of components (i.e., rotational, prismatic, deep drawn, sheet metal etc.)
- ii. The code structure
- iii. The digital representation (i.e., binary, octal, hexadecimal etc.)
- iv. Material of manufacture - ferrous, non ferrous, plastics, composites etc.

When using a code to represent an engineering design, it is important to represent the basic features of the design. For process planning, it is desirable to have codes that can distinguish unique production families.

Some of the coding systems that have been successfully implemented in process planning are given below:

- i. OPITZ system
- ii. The CODE system
- iii. The KK-3 system
- iv. The MICLASS system
- v. DCLASS system
- vi. COFORM (coding for machining)

When implementing a parts classification and coding system, most companies can purchase a commercially available package or develop a system for their own specific use.

Commercial systems have the advantage of less lead time in implementation. Brief treatment of some commercial systems is given in subsequent sections.

### 9.9 OPITZ CLASSIFICATION SYSTEM

The Opitz coding system uses the following digit sequence:

12345      6789      ABCD

The basic code consists of nine digits, which can be extended by adding four more digits. The first nine digits are intended to convey both design and manufacturing data. The general interpretation of the nine digits is indicated in Fig 9.5. The first five digits, 12345, are called the “form code” and describe the primary design attributes of the part. The next four digits, 6789, constitute the “supplementary code”. It indicates some of the attributes that would be of use to manufacturing (work material, raw work piece shape, and accuracy). The extra four digits, “ABCD”, are referred to as the “secondary code” and are intended to identify the production operation type and sequence. The secondary code can be designed by the firm to serve its own particular needs.

In the form code, the first digit identifies whether the part is a rotational or a non-rotational part. It also describes the general shape and proportions of the part. Fig 9.5 shows the specification scheme. For the rotational work pieces, the coding of the first five digits is given in Fig. 9.6.

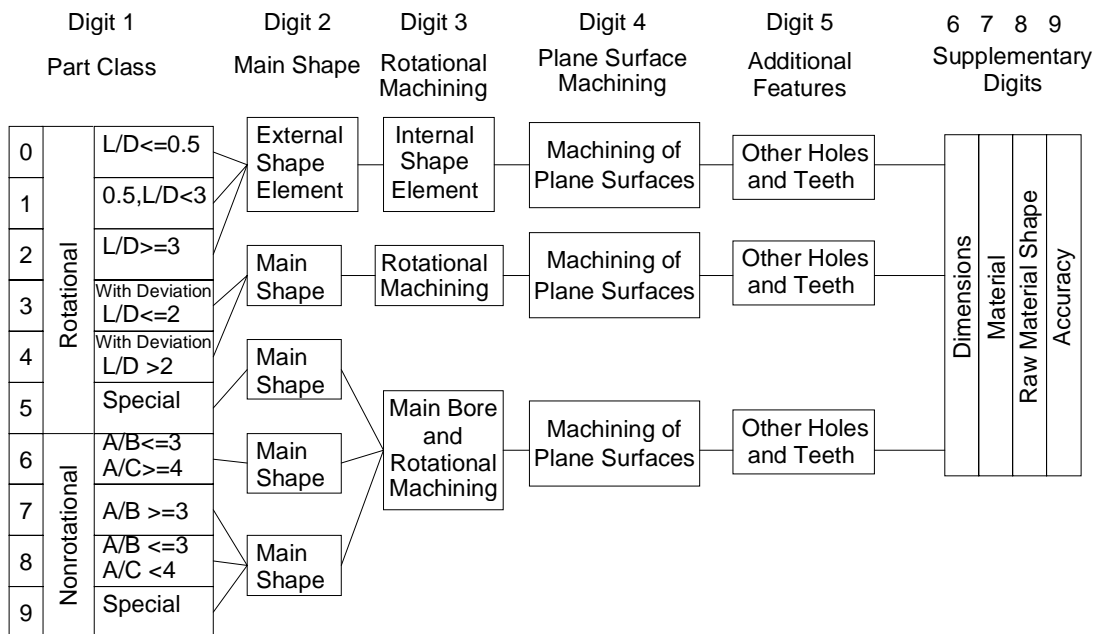


Fig. 9.5 Specification Scheme

DIGIT 1		DIGIT 2		DIGIT 3		DIGIT 4		DIGIT 5	
PART CLASS		External shape External Shape Elements		Internal Shape Internal Shape Elements		Plane Surface Machining		Auxiliary Holes and Gear Teeth	
0	Rotational Parts	L/D ≤ 0.5	0 Smoothing Shape Elements	0	No Hole, No Break Through		0	No Surface Machining	
1		0.5 < L/D < 3	1 No Shape Elements	1	No Shape Elements		1	Surface Plane/ Curved	
2		L/D > 3	2 Thread	2	Thread		2	External Plane Surface, Circular Graduation	
3	Non rotational Parts		3 Stepped one end or Smooth Groove	3	Smooth or Stepped on One End Groove		3	External Groove and/or Slot	
4			4 Stepped Both Ends No Shape Elements	4	Stepped Both Ends No Shape Elements		4	External Spline (Polygon)	
5			5 Stepped Both Ends Thread	5	Stepped Both Ends Thread		5	External Plane Surface/Slot Spline	
6			6 Stepped Both Ends Groove	6	Stepped Both Ends Groove		6	Internal Plane Surface or Slot	
7			7 Functional Cone	7	Functional Cone		7	Internal Spline (Polygon)	
8			8 Operating Speed	8	Operating Speed		8	Internal or Slot/ External Polygon	
9			9 All Others	9	All Others		9	All Others	

Fig. 9.6 Coding the First Five Digits

**EXAMPLE**

Given the part design of Fig. 9.7, the form code for this part is discussed below.

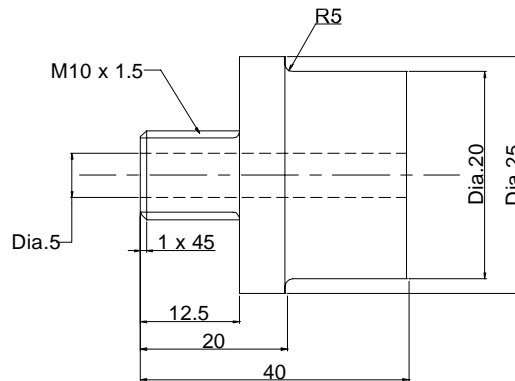


Fig. 9.7 Example Part

The overall length/diameter ratio,  $L/D = 1.6$ , so the first code = 1. The part is stepped on both ends with a screw thread on one end, so the second digit code would be 5 the third digit code is 1 because of the through hole. The fourth and fifth digits are both 0, since no surface machining is required and there are no auxiliary holes or gear teeth on the part. The complete form code in the Opitz system is "15100". To add the supplementary code, we would have to properly code the sixth through ninth digits with data on dimensions, material, starting work piece shape, and accuracy.

### 9.10 THE MICLASS SYSTEM

The MICLASS classification number can range from 12 to 30 digits. The first 12 digits are universal code that can be applied to any part. Up to 18 additional digits can be used to code data that are specific to the particular company or industry. For example, lot size, piece time, cost data, and operation sequence might be included in the 18 supplementary digits.

The component attributes coded in the first 12 digits of the MICLASS number are as follows:

1st digit	Main shape
2nd and 3rd digits	Shape elements
4th digit	Position of shape elements
5th and 6th digits	Main dimensions
7th digit	Dimension ratio
8th digit	Auxiliary dimension
9th and 10th digits	Tolerance codes
11th and 12th digits	Material codes

One of the unique features of MICLASS system is that parts can be coded using a computer interactively. To classify a given part design, the user responds to a series of questions asked by the computer. The number of questions depends on the complexity of the part. For a simple part, as few as seven questions are needed to classify the part. For an average part, the number of questions ranges between 10 and 20. On the basis of responses to its questions, the computer assigns a code number to the part.

### 9.11 THE CODE SYSTEM

The CODE system is a parts classification and coding system developed and marketed by Manufacturing Data System, Inc (MDSI), of Ann Arbor, Michigan. Its most universal application is in design engineering for retrieval of part design data, but it also has applications in manufacturing process planning, purchasing, tool design, and inventory control.

The code number has eight digits. For each digit, there are 16 possible values (zero through 9 and A through F) which are used to describe the parts design and manufacturing characteristics. The initial digit position indicates the basic geometry of the part and is called the major division of the code system. This digit would be used to specify whether the shape was cylinder, flat, block, or other. The interpretation of the remaining digits forms a chain-type structure. Hence the CODE system possesses a hybrid structure.

### 9.12 BENEFITS OF GROUP TECHNOLOGY

Implementation of group technology results in more focused factories. The likely impact of group technology can be seen in Table 9.2.

**Table 9.2 Impact of Group Technology**

<i>Before</i>	<i>After</i>
Discontinuous, Random Flow of Parts Through the Shop	Structured Flow of Parts
Reinvent New Parts	Retrieve Parts Already in Production
Multitude of Process Plans for Some Parts	Consistent, Single, Best Process Plans
Continuous Purchase of Components due to Lack of Total Visibility	Regulated Purchase of Components
Inflexible, Rigid, Unable to Respond to Changing Environment	Flexible

When group technology is applied, a manufacturing company will typically realize the following benefits:

***Product engineering -***

- Reduce part proliferation
- Help design standardization
- Provide manufacturing feed back

***Manufacturing engineering -***

- Process selection
- Tool selection
- Machine purchases
- Material handling

***Production engineering -***

- Reduce lead time
- Reduce delays
- Reduce set-up time
- Improve product quality

***Production planning and control -***

- Group scheduling
- Stock accountability
- Reduce expediting
- Improved product design
- Reduced materials handling
- Better employee satisfaction

**Other benefits:**

- Increased productivity
- Improved accuracy in estimation of costs
- Greater standardization and variety reduction
- Reduced set up times
- Better product delivery (Helps to implement just-in-time (JIT) manufacturing)
- Reduced cost of purchasing
- Improved plant efficiency

**9.13 PROCESS SELECTION**

Selecting the manufacturing processes to transform the raw material into the finished part is based on matching requirements with process capabilities. Process capability is the data base of knowledge for each process. It includes:

- i. The shape and size of part a process can produce
- ii. The dimensions and geometric tolerances that can be obtained
- iii. The surface finish attainable
- iv. The material removal rate
- v. The relative cost
- vi. Technological parameters

Process engineering does not necessarily imply that all process selection is based on the information above. However, the more the information considered in selecting a process, the more complete the result will be. A computer aided process planning system functions based on this process capability information.

Earlier it was mentioned that planning systems could be classified into variant and generative types. A variant planning system is a retrieval system and is analogous to planning based on experience. In the variant planning system, standard plans are stored based on component shape. These plans are then retrieved based on the similarity of a coded part. A generative system, however, makes processing, tooling and other decision via software logic.

**9.14 EXPERIENCE-BASED PLANNING**

It is always true that the accumulation of experience is knowledge. This is also true in the context of manufacturing process. Even now, many process planning activities still rely on the experience of the process planners. However, there are some problems associated with such a planning approach.

- i. Experience is gathered over a period of time.
- ii. Experience may not represent correct and current knowledge.
- iii. No experience will be available in the case of new processes.



Because of the problems noted above, it is necessary to seek more efficient ways to represent process capability knowledge base so that it might be preserved and installed as part of a decision support system on a computer.

### 9.15 HAND BOOKS/DATA BOOKS/MANUALS

One way to store the process information is to print it in a hand book or manual. This has been a standard practice. Process information is usually presented in tables, figures or listed as guide lines. Many manufacturers usually prepare their own manuals for internal use. Some process information is listed as guide lines, so that the process planners can follow some general rules. For example, the following guidelines can be applied to produce holes.

	<b><i>Diameter <math>\leq 8</math> mm</i></b>	<b><i>True position <math>&gt; 0.01</math></i></b>
i.	Tolerance $> H10$	Drill the hole.
ii.	Tolerance $\leq H8$	Drill and Ream etc.

### 9.16 DECISION TABLES AND DECISION TREES

Decision tables and decision trees are methods of describing or specifying the various actions (decisions) associated with combination of (input) conditions. Both methods have been used for a long time to help decision making. This is also suitable for use with digital computers.

### 9.17 PROCESS CAPABILITY

The process capability depends on the following factors:

- i. Shape that a process can generate.
- ii. Size limitation (boundaries of the tooling, machine tooling, and fixtures).
- iii. Tolerances (both dimensional and geometric).
- iv. Surface finish attainable.
- v. Cutting force.
- vi. Power consumption.

The shape element implies the basic geometry predicable by a process. However, this is difficult task to achieve using a computer that is reasoning the shape capabilities in its natural form (geometry and topology). A feasible alternative is to represent shape by a code. For internal machining process, the size capability is constrained by the available tool size. In external machining, size is constrained by the available machine table size. The other capabilities and limitations can be expressed mathematically. These expressions are straight forward to programme on a computer if the exact equations and constraints can be quantified.

One way to represent process capabilities is to use process boundaries. A process boundary is interpreted as the limiting size, tolerance and surface finish for a process. This can be obtained by careful control of the cutting conditions and process parameters (feed, speed, depth of cut). Machining force and power are not limiting values in process selection, but becomes an important consideration in selecting process parameters. A typical process boundary table is shown in Fig. 9.8.

<b>Boundary</b>	<b>Hole Producing Processes</b>	<b>Plane Producing Processes</b>
Smallest Tool Size		
Largest Tool Size		
Negative Tolerance		
Positive Tolerance		
Straightness(Holes)		
Parallelism		
Angularity (Planes) Roundness (Holes)		
Depth Limit		
True Position		
Surface Finish		

**Fig. 9.8 Process Boundary Table**

### 9.17.1 PROCESS PARAMETERS FOR MACHINING

Surface finish, force and power constraints are directly affected by the process parameters—feed, speed and depth of cut. Therefore, process selection becomes an iterative procedure: first a process is selected and then the machining parameters are adjusted to accommodate the system constraints.

- Selection of the machining parameters also affects the time and cost required to produce components.
- Several machinability systems are currently marketed that recommend sets of parameters that either optimize machining cost, time or production rate, or simply retrieve data table or calculated values.

One extensively used data system is CUT DATA from Machinability Data Systems of USA.

Recently computerized machinability systems have been introduced which facilitate quick selection of optimum process parameters.

### 9.17.2 COST AND TIME MODELS

Machining optimization models can be classified as single pass and multi pass models. In a single pass model, we assume that only one pass is needed to produce the required geometry. In this case, depth of cut is fixed. In multi pass model, this assumption is relaxed and depth of cut also becomes a control variable.

## 9.18 METHODS OF COMPUTER AIDED PROCESS PLANNING

The ultimate goal of a system is to integrate design and production data into a system that generates useable process plans. As already mentioned there are two approaches:

- i. Variant process planning
- ii. Generative process planning

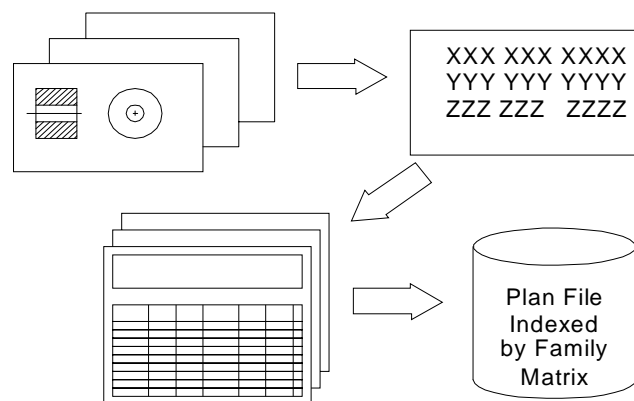
## 9.19 VARIANT PROCESS PLANNING

A variant process planning system uses the similarity among components to retrieve the existing process plans. A process plan that can be used by a family of components is called a standard plan. A standard plan is stored permanently with a family number as its key.

A family is represented by a family matrix which includes all possible members. The variant process planning system has two operational stages:

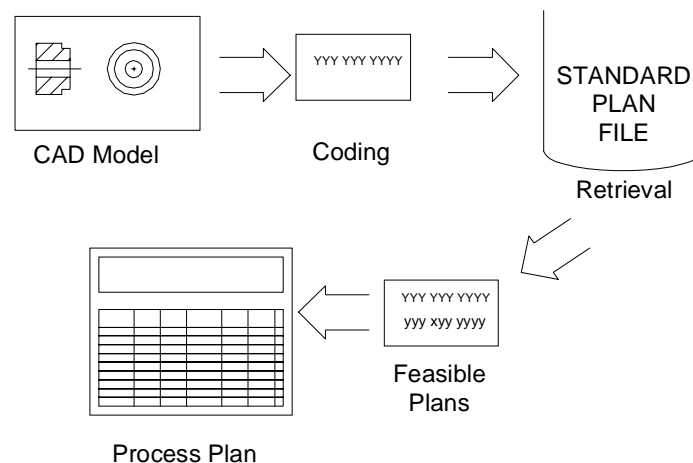
- A preparatory stage and
- A production stage.

During the preparatory stage, existing components are coded, classified, and subsequently grouped into families. The process begins by summarizing process plans already prepared for components in the family. Standard plans are then stored in a data base and indexed by family matrices (Fig. 9.9).



**Fig. 9.9 Process Family Matrix**

The operation stage occurs when the system is ready for production. An incoming part is first coded. The code is then input to a part family search routine to find the family to which the component belongs. The family number is then used to retrieve a standard plan. Some other functions, such as parameter selection and standard time calculations, can also be added to make the system more complete (Fig. 9.10). This system is used in a machine shop that produces a variety of small components.



**Fig. 9.10 Part Search and Retrieval**

### 9.19.1 DESIGN OF VARIANT PROCESS PLANNING SYSTEM

The following are the sequences in the design of a variant process planning system:

- i. Family formation
- ii. Data base structure design
- iii. Search algorithm development and implementation
- iv. Plan editing
- v. Process parameter selection/updating

#### 9.19.1.1 Family Formation

Part family classification and coding were discussed earlier. This is based on the manufacturing features of a part. Components requiring similar processes are grouped into the same family. A general rule for part family formation is that all parts must be related. Then, a standard process plan can be shared by the entire family. Minimum modification on the standard plan will be required for such family members.

#### 9.19.2 DATA BASE STRUCTURE DESIGN

The data base contains all the necessary information for an application, and can be accessed by several programs for specific application. There are three approaches to construct a data base: hierarchical, network, and relational.

### 9.19.3 SEARCH PROCEDURE

The principle of a variant system is to retrieve process plans for similar components. The search for a process plan is based on the search of a part family to which the component belongs. When, the part family is found, the associated standard plan can then be retrieved. A family matrix search can be seen as the matching of the family with a given code. Family matrices can be considered as masks. Whenever, a code can pass through a mask successfully, the family is identified.

### 9.19.4 PLAN EDITING AND PARAMETER SELECTION

Before a process plan can be issued to the shop, some modification of the standard plan may be necessary, and process parameters must be added to the plan. There are two types of plan editing: One is the editing of the standard plan itself in the data base, and the other is editing of the plan for the component. For editing a standard plan, the structure of the data base must be flexible enough for expansion, additions, and deletions of the data records.

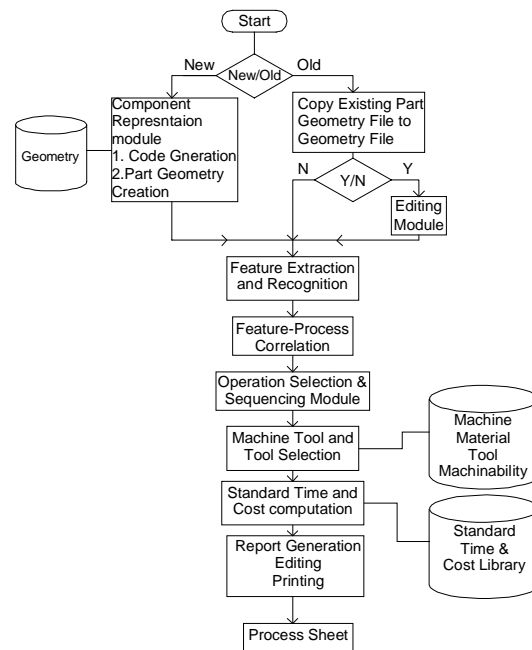
A complete process plan includes not only operations but also process parameters. The data in the process parameter files are linked so that we can go through the tree to find the speed and feed for an operation. The parameter file can be integrated into variant planning to select process parameters automatically.

## 9.20 GENERATIVE PROCESS PLANNING

Generative process planning is a system that synthesizes process information in order to create a process plan for a new component automatically. In a generative planning system, process plans are created from information available in manufacturing data base without human intervention. Upon receiving the design model, the system can generate the required operations and operation sequences for the component. Knowledge of manufacturing must be captured and encoded into efficient software. By applying decision logic, a process planner's decision making can be imitated. Other planning functions, such as machine selection, tool selection, process optimization, and so on, can also be automated using generative planning techniques. The generative planning has the following advantages:

- i. It can generate consistent process plans rapidly.
- ii. New process plans can be created as easily as retrieving the plans of existing components.
- iii. It can be interfaced with an automated manufacturing facility to provide detailed and up-to-date control information.

Fig. 9.11 shows the modular structure of a generative CAPP system.



**Fig. 9.11 Modular Structure of a Generative CAPP System**

**The generative part consists of:**

- Component representation module
- Feature extraction module
- Feature process correlation module
- Operation selection and sequencing module
- Machine tool selection module
- Standard time / cost computation module
- Report generation module

In order to generate a more universal process planning system, variables such as process limitations, and capabilities, process costs and so on, must be defined at the planning stage. Several of methods have been proposed for creating generative process plans. A few methods that have been implemented successfully are:

- i. Forward and backward planning
- ii. Input Format
- iii. CAPP based on CAD models
- iv. CAPP based on decision logic either using decision trees or decision tables
- v. CAPP based on artificial intelligence

### 9.20.1 FORWARD AND BACKWARD PLANNING

In generative process planning, when process plans are generated, the system must define an initial state in order to reach the final state (goal). The path taken represents the sequence of processes. For example, the initial state is the raw material and the final state is the component design. Then a planner works in modifying the raw workpiece until it takes on the final design qualities. This is called forward planning.

Backward planning uses a reverse procedure. Assuming that we have a finished component, the goal is to go back to the un-machined workpiece. Each machining process is considered a filling process.

Forward and backward planning may seem similar. However they influence the programming of the system significantly. Planning each process can be characterized by a precondition of the surface to be machined and a post condition of the machining (the end result). For forward planning, we must know the successor surface before we select a process, because the post condition of the first process becomes the precondition for second process. Backward planning eliminates this problem since it begins with the final surfaces from and processes are selected to satisfy the initial requirements.

In forward planning, the steps to obtain the final surface with the desirable attributes must be carefully planned to guarantee the result. On the other hand, backward planning starts with the final requirements and searches for the initial condition.

### 9.20.2 INPUT FORMAT

The input format of a process planning system affects the ease with which a system can be used, and the capability of the system. The transitional form from the original design (either engineering drawing or CAD model) to a specific input format may be tedious and difficult to automate. However, such input can provide more complete information about a component, and more planning functions can be accomplished using the input.

Many different input formats have been used in process planning systems. Some of the few input formats used are:

**CODE:** Some generative systems such as APPAS use GT codes as input. Codes used are in generative system are more detailed.

**DESCRIPTION LANGUAGE:** Specially designed part description languages can provide detailed information for process planning system. For example AUTAP system uses a language similar to a solid modeling language. A component is described by the union of some primitives and modifiers. Material, processes, machine selection, and time estimates can be selected by the system using the input model. Another system CIMS/PRO uses an input language called CIMS/DEC. CAPP system uses its own special language.

### 9.20.3 CAPP BASED ON CAD MODELS

Using a CAD model as input to a process planning system can eliminate the human effort of translating a design into code and other descriptive form. A CAD model contains

all the details about a design. However, an algorithm is necessary to identify a general machined surface in a CAD model. Additional code is needed to convert the machined surface shape from raw material shape. CAD/CAM system uses a CAD model as its input. Several other systems such as GENPLAN, AUTOPLAN, etc., also use a CAD database interactively for tool and fixture selection.

#### 9.20.4 CAPP BASED ON DECISION LOGIC

The decision logic determines how a process or processes are selected. The major function of the decision logic is to match the process capabilities with the design specification. The different techniques in decision logic are:

- i. Decision trees
- ii. Decision tables

These two techniques are methods of describing or specifying the various actions associated with the combination of input conditions.

#### 9.20.5 CAPP BASED ON ARTIFICIAL INTELLIGENCE (AI)

AI can be defined as the ability of a device to perform functions that are normally associated with the human intelligence. These functions include reasoning, planning, and problem solving. Applications for AI have been in natural language processing, intelligent data base retrieval, expert consulting systems, theorem proving, robotics, scheduling, and perception problems. Process planning applications have been considered as part of an expert consulting system.

There are two types of knowledge involved in process planning systems: Component knowledge, and process knowledge. The component knowledge defines the current state of the problem to be solved (declarative knowledge). On the other hand, the knowledge of processes defines how the component can be changed by processes (procedural knowledge).

There are several methods to represent declarative knowledge:

- i. First order predicate calculus
- ii. Frames and semantic networks

Procedural knowledge can be represented by IF (condition), THEN (action) statements which are similar to decision trees or decision tables. In AI such rules can be called production rules.

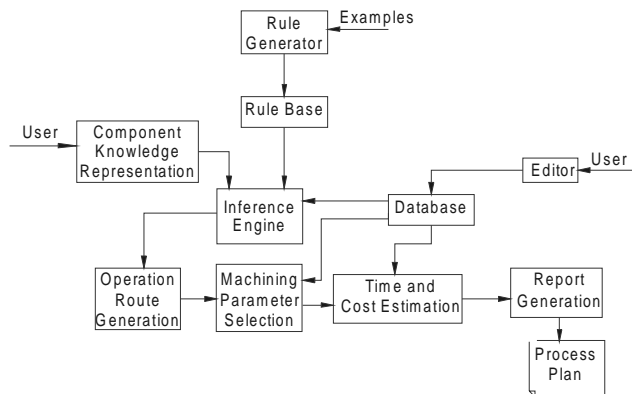
Even after the descriptive and procedural knowledge have been represented, conclusions cannot be deduced, because we do not have mechanism to apply the appropriate rules to the problem. Control knowledge is similar to human knowledge in reasoning, which deduces certain facts from the knowledge base concerning problem. This can be a difficult task to program on a computer.

Computer Aided Process Planning has been an active area of research work in AI for many years. Feature recognition, feature process correlation, process sequencing, blank



selection, cutting parameter selection, tool selection etc. are the segments of CAPP where AI can contribute to improve the quality of process plans.

The block diagram representation of an expert CAPP system is shown in Fig. 9.12.



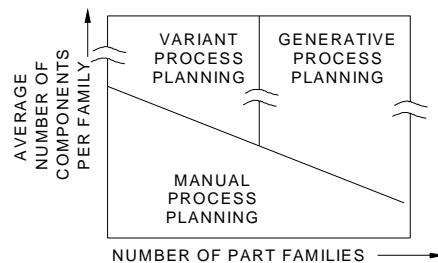
**Fig. 9.12 Block Diagram of Expert CAPP System**

## 9.21 IMPLEMENTATION CONSIDERATIONS

The process planning function is manufacturing system dependent. This implies that no one single process planning system can satisfy all of the different manufacturing systems needs. There are several factors that must be considered when one attempts to implement a process planning system. These include:

- i. Manufacturing system components
- ii. Production volume/batch size
- iii. Number of different production families

For a moderate number of component families and many similar components in each family, a variant process planning system is usually the most economic automated planning alternative. Fig. 9.13 Illustrates the economic regions for the different planning alternatives.



**Fig. 9.13 Economic Regions for Different Types of Process Planning**

## 9.22 PROCESS PLANNING SYSTEMS

The majority of existing process planning systems is based on variant process planning approach. Some of them are: CAPP, MIPLAN, MITURN, MIAPP, UNIVATION, CINTURN, COMCAPPV, etc. However, there are some generative system, such as METCAPP, CPPP, AUTAP, and APPAS. Some of the planning systems are discussed in the following paragraph. These are systems continuously evolving in many cases. The descriptions are therefore only approximate.

### 9.22.1 CAM-I CAPP

The CAM-I (Computer Aided Manufacturing-International) system (CAPP) is perhaps the most widely used of all process planning systems. CAPP is a database management system written in ANSI standard FORTRAN. It provides a structure for a data base, retrieval logic, and interactive editing capability. The coding scheme for part classification and the output format are added by the user.

PI-CAPP, an extension of CAPP, has its own (built-in) coding and classification system. This eliminates the requirement of a user developed coding scheme. A typical CAPP system is shown in Fig. 9.14.

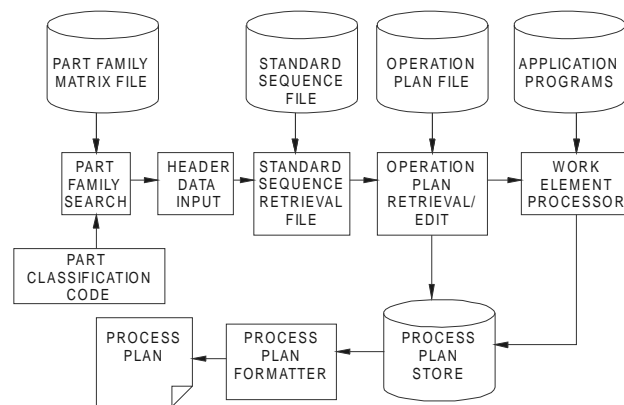
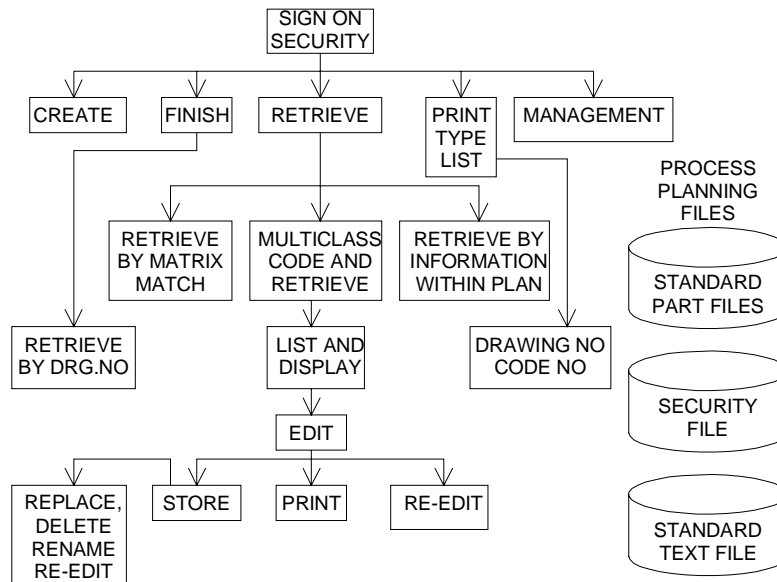


Fig. 9.14 CAPP System

### 9.22.2 MIPLAN AND MULTICAPP

Both MIPLAN and MULTICAPP were developed in conjunction with OIR (Organization for Industrial Research). They are both variant systems that use the MICLASS coding system for part description. They are data retrieval systems which retrieve process plans based on part code, part number, family matrix, and code range. By inputting a part code, parts with a similar code are retrieved. The process plan for each part is then displayed and edited by the user. A typical MULTICAPP system is shown in Fig. 9.15.



**Fig. 9.15 MULTICAPP System**

### 9.22.3 APPAS AND CADCAM

APPAS is a generative system for detailed process selection. CADCAM is an example of APPAS. CADCAM operates using a CAD “front end” to interface with APPAS. APPAS describes the detailed technological information of each machined surface by means of a special code. CADCAM provides an interactive graphics interface to APPAS. Components can be modeled graphically and edited interactively.

### 9.22.4 AUTOPLAN AND RPO

AUTOPLAN is generative only in the detailing of the part. The process selection and process sequencing level do not differ significantly from CAPP or MIPLAN. The four major modules of the system are:

- i. Group technology retrieval-process plan retrieval.
- ii. Graphical planning aides- tooling layout, verification and work instruction and preparation.
- iii. Generative process planning.
- iv. Process optimization.

### 9.22.5 AUTAP SYSTEM

The AUTAP system is one of the most complete planning systems in use today. AUTAP uses primitives to construct a part similar to a constructive solid geometry (CSG). AUTAP is a system designed especially to interface with a CAD system. It can be installed as part of an integrated CAD/CAM system.

### 9.22.6 CPPP

CPPP (computerized production process planning) was designed for planning cylindrical parts. CPPP is capable of generating a summary of operations and the detailed operation sheets required for production. The principle behind CPPP is a composite component concept. A composite component can be thought of as an imaginary component which contains all the features of components in one part family. CPPP incorporates a special language, COPPL, to describe the process model. CPPP allows an interactive mode whereby the planner can interact with the system at several fixed interaction points.

### 9.22.7 GARI

GARI is an experimental problem solver which uses artificial intelligence (AI) techniques. The unique feature of the GARI is the representation of planning knowledge. GARI employs a production rule knowledge base to store process capabilities.

### 9.22.8 TIPPS

Although the process planning steps have been discussed, an integrated approach to generative process planning has yet to be presented. TIPPS is acronym for Totally Integrated Process planning. TIPPS is generative process planning system that has evolved from the APPAS and CAD/CAM systems. In TIPPS, the logical divisions of process planning are broken into functional modules. TIPPS has the following features:

- It has a modular structure
- It can interact with a CAD system
- It allows for interactive surface identification
- It contains a process/knowledge description language

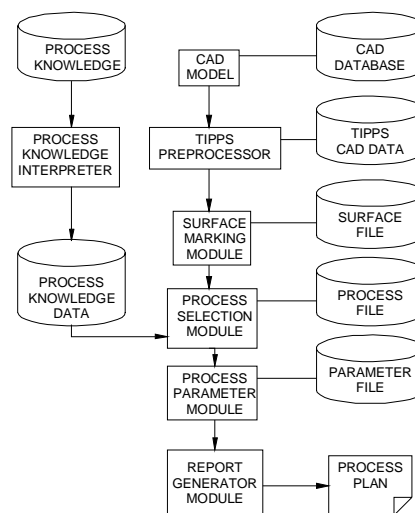
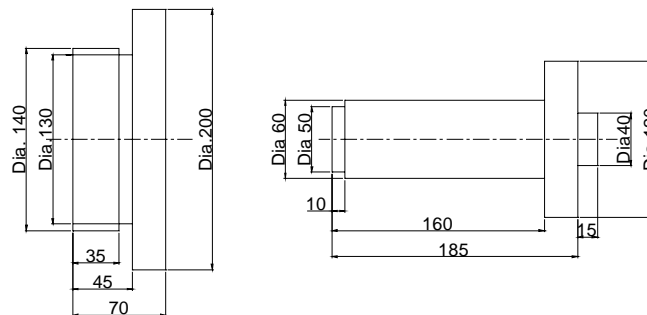


Fig. 9.16 TIPPS

Figure 9.16 shows a block diagram representation of TIPPS software.

## QUESTIONS

1. Discuss the importance of process planning in product development.
2. What is the need for computer aided process planning? What are its advantages?
3. Describe the structure of a process plan.
4. What are the major modules of a process planning software and the databases required?
5. What is the need for CAD based process plans?
6. Discuss the principle and advantages of group technology coding.
7. Classify a component using either OPITZ or MICLASS system.
8. Discuss the principle of variant process planning.
9. What is generative process planning?
10. What are the modules of a generative process planning software?
11. Compare variant and generative process planning methodologies.
12. Describe any one computer aided process planning software.
13. Discuss how group technology is used in designing manufacturing cells.
14. How could artificial intelligence (AI) be used in generative process planning?
15. Two components are shown in Fig. 9.17. Do they belong to the same part family? Discuss.



**Fig. 9.17 Rotational Components**

# PLANNING OF RESOURCES FOR MANUFACTURING THROUGH INFORMATION SYSTEMS

*Information systems are used to organize and manage the manufacturing environment, and to deliver manufacturing information in a useful and timely fashion to various sub-systems of manufacturing to create dynamic enterprises. An efficient enterprise resources planning system will help to increase the productivity in manufacturing and improve profits and market share applications. There are a number of manufacturing planning system packages and enterprise resource planning systems available today for a wide range of micro, mini and main frame installations from various vendors. This chapter deals with the segments of manufacturing resource planning and introduces ERP, dynamic enterprise modeling and supply chain management.*

## 10.1 INTRODUCTION

Manufacturing companies, large and small, continually seek to improve response to customers, increase profitability and become more competitive. Their aim is to make savings in working capital by reducing stocks, service and support costs whilst improving cycle times, deliveries and quality. Advanced computer based management planning and control systems help to achieve these aims.

In recent years due to the pressure of globalization, the highly competitive world of manufacturing has grown increasingly complex. As new methods for production and inventory control have arisen and demands for increased productivity have mounted, proper manufacturing planning and control of manufacturing resources have become essential. The concept of manufacturing planning has been enlarged to include the entire enterprise covering such critical issues like logistics and supply chain management. In fact, efficiency of information management and proper manufacturing planning create strategic advantages that can translate into increased market share and improved profit margins. The need for proper planning and execution of manufacturing plans has resulted

in the development of IT based systems to organize and manage the manufacturing to all users concerned.

## 10.2 BACKGROUND

In the 1960's with the population of computers and their popularity growing, manufacturers looked for ways to use them to facilitate ordering of materials and parts for their manufacturing goods. This resulted in the development of software called MRP (Material Requirement Planning). MRP was a simple computer program for planning material orders with the purpose of reducing inventory, responding more effectively to market demand, and ultimately increasing sales.

MRP is a time-phased planning system that detects when the due date of an order is out of phase with its "need date", and ultimately keeps the priorities valid in a changing manufacturing environment. The original MRP programs linked material requirements with inventory levels and replenishment purchase orders and work orders over a time frame. MRP brought out discrepancies and helped to restore a balance between the inventory requirements and replenishments. The program determined net requirements for every manufactured and purchased component and created planned purchase orders or work orders for these items.

The managers were then required to either confirm the orders or change the quantities or due dates. MRP was a very good management planning tool, if the indicated manufacturing lead time and the inventory levels were correct. Despite this method, which improved inventory control and material planning, many manufacturers realized there were several segments in the manufacturing chain that were missing. They constantly felt that there was more to their job than monitoring material availability.

This led to the development of manufacturing resource planning or MRP II. MRP-II systems go far beyond the planning tools of MRP. They are in effect manufacturing control systems. These systems can plan, track, and control almost any aspect of manufacturing, from inventory levels to job costing, to the placement of finished goods on the proper truck to get to the right distributor. However, as the compulsions of the global competition and complexities of economic manufacturing grew the manufacturers had to go for more efficient planning tools. This led to the development of enterprise resource planning (ERP). ERP attempts a dynamic enterprise modeling which can respond to any exigencies of a manufacturing and marketing demand. Further, manufacturers are implementing efficient supply chain management systems to keep customers happy and maintain their profit levels. Information Technology (IT) has thus become the back bone of manufacturing activity.

A word of caution may not be out of place here. Any manufacturing system will not give the desired results unless the focus is on continuous improvement. Traditionally, systems have been designed "top down." In simple terms, the approach has been one of imitating the "push system". This is in contrast with the Toyota Production System (TPS)

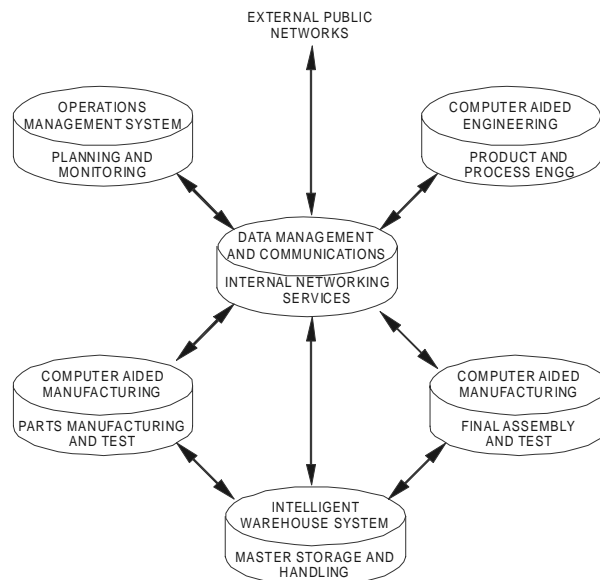
where the emphasis is on making people involved think. The reason why a mention is made here of TPS is that proper understanding and follow up can improve production efficiency and cut down lead time and cost.

### 10.3 ROLE OF MRP-II IN A CIM SYSTEM

Figure 10.1 shows a typical networked CIM system. The important modules of the system are:

- i. Computer Aided Engineering
- ii. Operations Management
- iii. Computer Aided Manufacturing
- iv. Intelligent Warehouse System

It can be seen that the systems are linked to a central data storage system to enable different departments to share the manufacturing data. The manufacturing information system ties the activities of several departments together in a closed loop for effective manufacturing control to achieve high productivity. It is necessary to understand the functioning of various segments of a manufacturing system to appreciate the complexities of working of an enterprise. The modules of MRP-II are, therefore, discussed in detail in this chapter. The figure highlights the importance of data as well as materials. The efficiency in manufacturing is dependant on timely access to data and availability of materials. A CIM system serves exactly the same purpose.



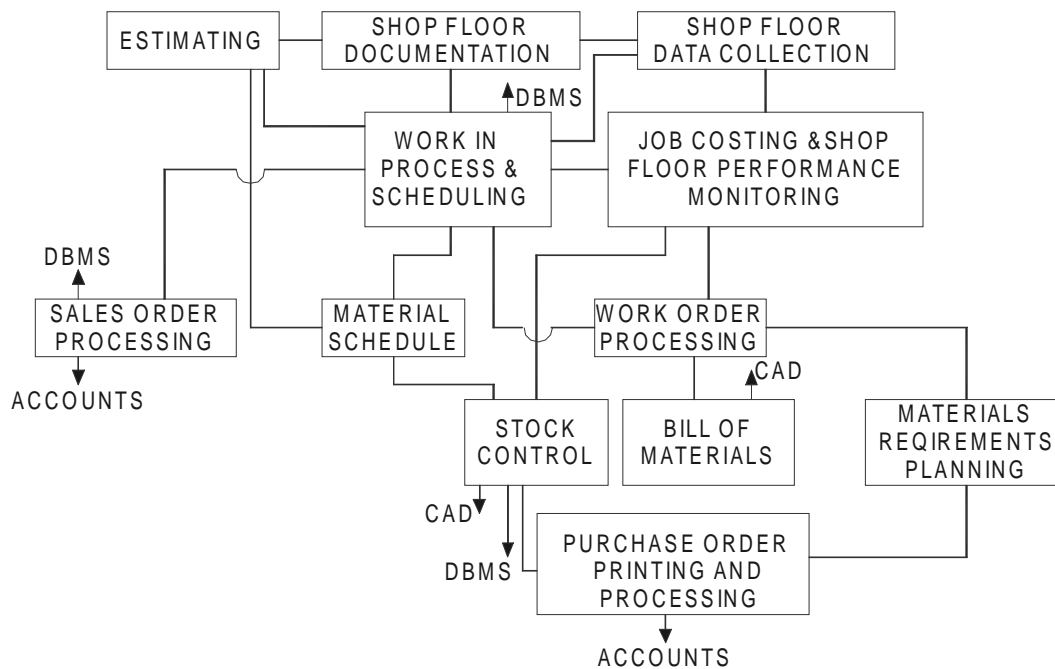
**Fig. 10.1 A Typical Networked CIM System**



## 10.4 MAJOR MODULES OF A MANUFACTURING RESOURCES PLANNING (MRP) SOFTWARE

The important applications of a typical manufacturing resources planning system are shown in Fig. 10.2. The interrelationship of various activities is clearly marked in the diagram. The various modules that are part of a good MRP-II system are listed below:

- i. Manufacturing Applications
- ii. Engineering Applications
- iii. Financial Applications
- iv. Marketing Applications



*Fig. 10.2 Applications of a Typical MRP-II System*

## 10.5 MANUFACTURING APPLICATIONS

### 10.5.1 BUSINESS PLAN

A closed-loop MRP-II system starts, at the highest level, with a business plan which is a statement about what business a company is in. Does it make pumps, machine tools, automobile parts, or electrical motors? This plan also includes the models of pumps, machine tools, automobile parts or electronic motors and any new models or types being introduced, as well as the long-term business strategy for the company.

### 10.5.2 PRODUCTION PLAN

The information from the business plan, along with sales and market forecasts, is fed into the production plan. The production plan determines, on a gross level, how many of which products should be manufactured. Even in a make-to-order environment, a company has to have some idea of what business will be like in the year ahead.

### 10.5.3 MASTER PRODUCTION SCHEDULE (MPS)

The production plan is in turn translated into the master production schedule (MPS). The master schedule is a macro level document which sets top-level priorities for what will be manufactured and when, looking at the material that will be required over the production cycle.

The MPS planning period, or horizon, can be of any length, but should be at least as long as a company’s longest cumulative lead time (the time it takes to complete a product from raw material to finished goods.). Many systems include a rough cut capacity planning (RCCP) capability, which compares certain MPS items of the master schedule to specified key resources of the plant (or multiple plants) to determine if the master schedule is workable, given current the plant capacity. If the master schedule is not achievable, the system modifies the MPS or the production plan (For example, reduce the amount of products to be produced or commit to increasing the capacity of the plant) until the master schedule is achievable.

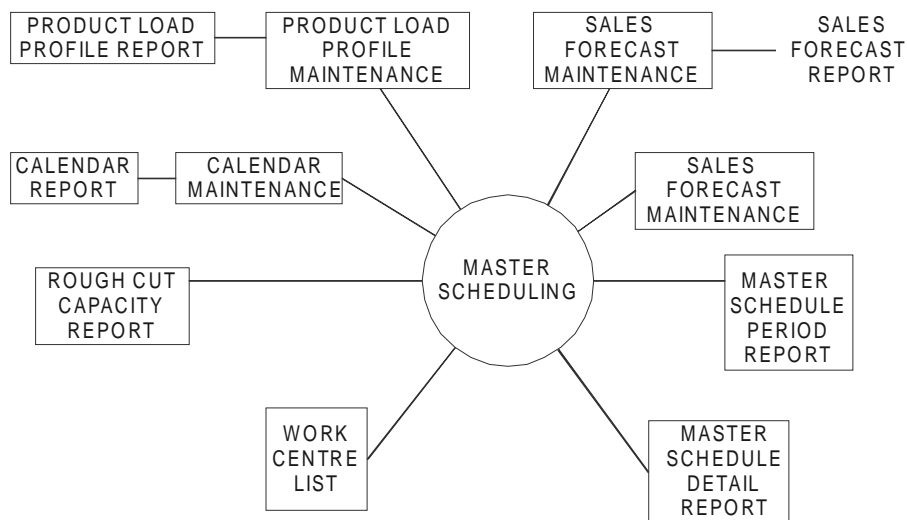


Fig. 10.3 Modules of Master Scheduling

Master production schedule provides great flexibility in reflecting the overall production plans of management, allowing planned production to be based on predicted demand. (Refer Fig. 10.3)

The master production schedule software is useful in many ways.

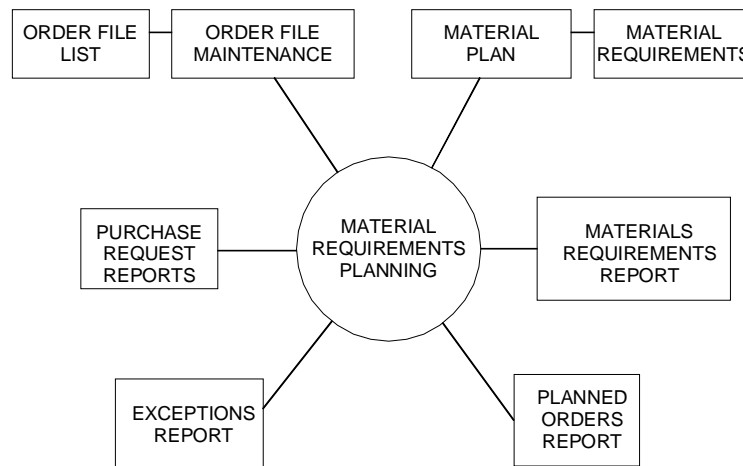
- Enables the user to scan through the file starting at any point to easily locate data.
- Accesses items by number or partial description.
- Eases forecasting.
- Allows interactive entry of requirement and replenishment orders on the master schedule including creation of firm planned orders.
- Merges existing shop orders, purchase orders, and MRP planned orders into the master schedule for easy comparison with customer orders and sales forecast orders.
- Maintains orders by exact date, allowing reports to be detailed or summarizes into a variety of user-defined periods.
- Supports “what if” analysis by projecting into the future with adjustments to quantities.
- Displays or prints how much of each inventory item is available to promise for delivery in current and future periods.
- Identifies under or over-scheduled key work centres though rough cut capacity planning.
- Pinpoints desired information responding to user-specified parameters.

#### **10.5.4 MATERIALS REQUIREMENTS PLANNING**

The master production schedule becomes a direct input to the material requirements planning (MRP) function, which determines the material needed at each work centre location in order to meet the master production schedule. MRP is the heart of any manufacturing control system. It uses information from the bills of material, inventory, shop and purchase orders, and the master schedule to draw a detailed material requirements plan. MRP accesses the data from the master production to determine what products will be built during the planning period.

Bills of material and routings define the raw materials required to produce the product, the instructions and routing(s) through the shop the shop floor for producing the product. MRP determines the total gross requirements and compares against current inventory and scheduled receipts (any replenishment orders due).

If MRP determines that material will not be available when it is required, it can regenerate planned orders for that material. Figure 10.4 illustrates the important sub-modules of MRP.



**Fig. 10.4 Sub-modules of Material Requirements Planning**

The MRP modules carry out the following:

- Computes when and in what quantities component parts and raw materials are required.
- Supports minimum, maximum, and multiple order quantity modifications.
- Allows creation and modification of a shop calendar and a variety of reporting calendars.
- Reports exceptions and recommends changes to order quantities and dates.
- Supports changes in product structures.
- Uses actual components planned for shop orders as a firm planned bill of material to accurately reflect true material needs.

### 10.5.5 CAPACITY REQUIREMENTS PLANNING (CRP)

MRP does not consider available capacity and often formulates production plans not possible within a given specified plant capacity. Capacity Requirements Planning (CRP) takes planned orders from MRP and open (release) shop orders, and translates work orders into hours of work (pre-set standards) on a work centre basis.

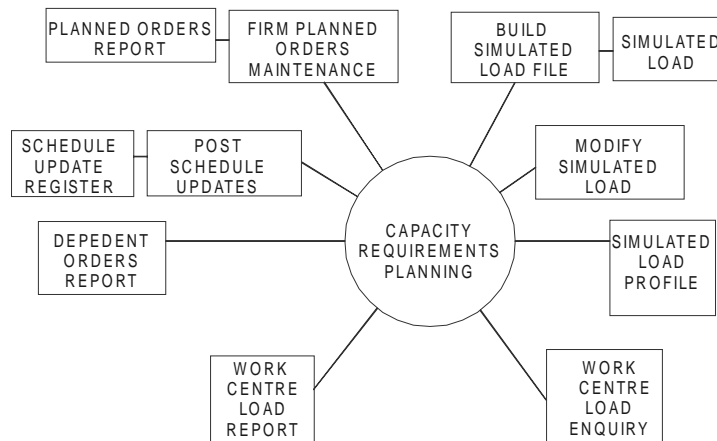
CRP then, using the cumulative lead times, allocates the work required for each order to the appropriate work centres for the time period that the order will be in that work centre. CRP considers many factors in allocating the load-queue time, move time, machine and many others. In scheduling, CRP can start from current date and schedule the job to completion (forward scheduling) or using the due date for the order, schedule backwards to determine the start date of the job (backward scheduling).

There are two types of loading in CRP: finite and infinite. With finite loading, CRP considers the total capacity of a work centre and does not load beyond that point. Infinite loading loads

all work for the period into the appropriate work centres then produces over and under load reports showing where more or less capacity are needed to efficiently handle the load.

Although they may generate suggestions, most MRP systems require human intervention to help balance the capacity and load. A planner can decide whether delaying the order release, subcontracting the job, splitting the job into several smaller jobs, routing through an alternative work centre, or authorizing overtime will best eliminate the over-/under load on the work centre and still get the job done on time.

Another aspect of CRP is Input/Output control (I/O). I/O control monitors the amount of work going into and coming out of a work centre and compares it to a standard or expected amount. A back log will develop behind any work centre that continually puts out less work than it takes in. CRP and I/O control are good tools for monitoring the shop floor for bottlenecks and unused capacity. The sub-modules of CRP software are shown in Fig. 10.5.



**Fig. 10.5 Modules of Capacity Requirement Planning**

The CRP software

- Allows an unlimited planning horizon with user-defined reporting period lengths
- Represents the load profile for each work centre.
- Provides an effective analysis tool to help maximize facility utilization and minimize delays.
- Gives advance knowledge of potential production bottlenecks so that the user can increase capacity, decrease the load or change the schedule to create a realistic production plan.
- Monitors both current wok-in-process and planned production concurrently.
- Displays the schedule load for any work centre.
- Allows the user to test various “what-if” changes without affecting the “live” date.
- Uses both forward and backward scheduling techniques around a “bottleneck” operation.

- Reschedules any number of dependent shop orders when desired.
- Prints the “work centre load report” with planned load subtotals for each reporting period.
- Uses work centre efficiency factors in calculating capacity to match runtimes to reality.
- Pinpoints desired information by accepting user-specified parameters on most reports.
- Allows reports to be displayed on the screen for immediate inquiry.

### 10.5.6 SHOP FLOOR CONTROL

The previous modules discussed cover the planning phase of MRP-II. The actual implementation starts with shop floor control (SFC, also called production activity control-PAC). The SFC or PAC module monitors all shop floor activities and communicates status information on manufacturing orders and work centres back to respective managers. SFC determines what orders are released to the floor and when, the routing of a particular order, and when operations are to be started and completed. It also maintains the paperwork and details concerning an order, and handles feedback (either manual or automated) on the status of an order. Dispatch lists are generated, showing the jobs coming into a work centre and the preferred order of their completion. SFC reacts to changes and reschedules the work in response to priority changes. It also interfaces with the Capacity Requirements Planning component to provide input/output data for capacity planning purposes. With this process, overloaded or under loaded work centres can be identified to provide more effective work centre utilization. Figure 10.6 shows typical modules in SFC software.

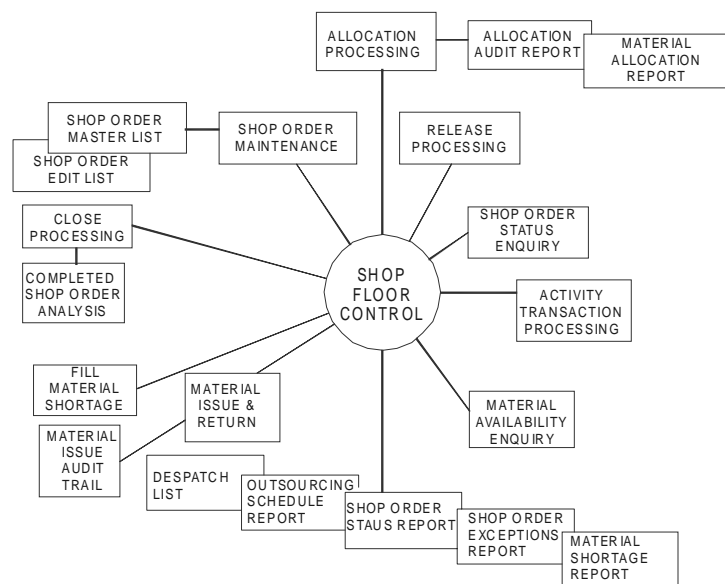
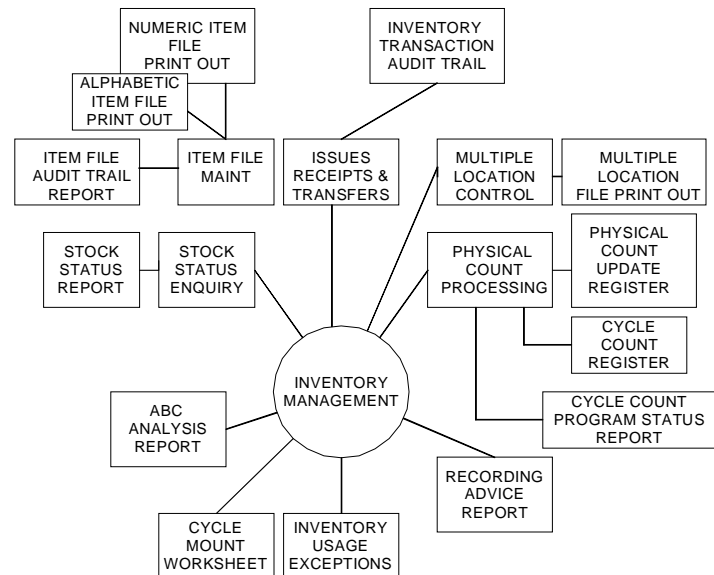


Fig. 10.6 Modules of Shop Floor Control

### 10.5.7 INVENTORY MANAGEMENT (REFER FIG 10.7)

Inventory is crucial element in any manufacturing environment, and its efficient control is an essential element for an MRP environment. Inventory systems integrate with nearly all components of the MRP system and must manage the balance between required inventory and available inventory. The inventory control (IC) component must control the issue and transfer of material and adjust inventory levels. In a repetitive manufacturing environment, the IC module is responsible for monitoring the number of inventory turns per year, with the objectives of increasing the number of turns to maximize profit margins. Some MRP packages offer features such as theoretical consumption and back flushing for the process industry.



**Fig.10.7 Modules of Inventory Management**

The Inventory Management module usually has the following capabilities:

- Creates audit trails with the exact time and operator for major files to provide a record of additions, changes, and deletions.
- Prints the ABC Analysis report with optional update of inventory classifications.
- Prints the Inventory Usage Exceptions Report comparing actual to forecast usage.
- Provides physical count tag support and cycle counting work sheets.
- Allows quick inquiry regarding the availability of any item.

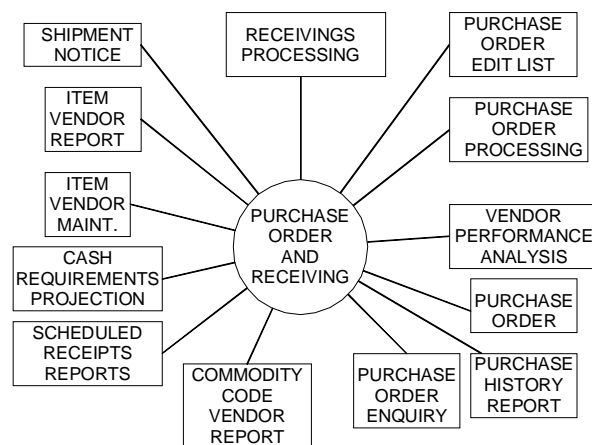
### 10.5.8 PURCHASE ORDER AND RECEIVING

In an effort to reduce costs and to keep inventory at a minimum, the purchasing component takes care of delivery lead times; projected inventory needs, and cost trends.

The purchasing process should allow enough versatility to set up multiple buying groups, such as divisions, departments, or plants.

Purchasing receives input from the Inventory Control component in the form of current and anticipated inventory levels. Material Requirements Planning also provides input on the planned inventory use and generates planned requisitions for purchased parts. With the increasing trend toward a Just-In-Time (JIT) manufacturing environment, and its emphasis on a reduction of inventory and a more even flow of parts from suppliers, the purchasing component should also accommodate this increased frequency of inventory receipt.

Purchase Order and Receiving (P/O) is an efficient, time-saving tool for creating and maintaining purchase records and ensuring the quality, accuracy, and promptness of deliveries of purchased materials. Figure 10.8 shows the sub-modules of purchase order and receiving module.



**Fig. 10.8 Purchase Order and Receiving**

The purchase order and receiving package has the following functionalities:

- Access to vendors and inventory items.
- Allows on-line entry and editing of regular and blanket purchase orders.
- Prints purchase orders, correct purchase orders, and cancellations.
- Reports those items that are scheduled to be received.
- Allows on-line entry of receiving and rejections with reject reasons
- Supports purchasing of materials that are shipped directly to customers.
- Provides powerful vendor analysis showing records of quality and price variance.
- Prints the cash Requirements Projection Report.
- Notifies the user when early shipments and over/under shipments occur.
- Records multiple vendors' part numbers for each inventory item.



### 10.5.9 COST ACCOUNTING

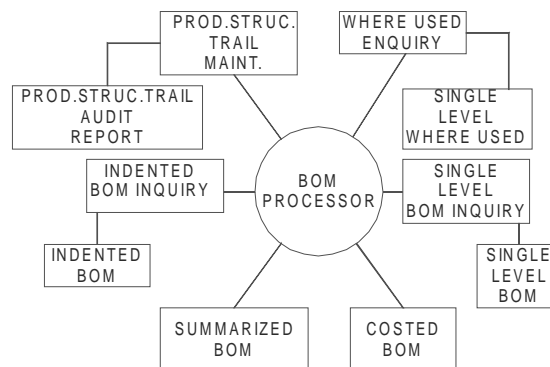
In its effort to maintain profitability and to meet the goals of the business plan, any manufacturing environment must control and monitor its costs, and know the cost of the final products. Depending on the type of manufacturing performed, various types of cost accounting may be required, and the cost accounting component of a manufacturing control system should accommodate each. The major costing elements include material and labour, variable and fixed overhead, machine set up cost, and subcontractor costs. Since many manufacturing settings vary, it is important that the cost accounting procedure models a company's particular environment. For example, labour costs and the incremental cost of the use of expensive machines may be a larger part of the actual job cost than material costs in one setting; therefore, the cost accounting procedure must adequately monitor and control those costs.

## 10.6 ENGINEERING APPLICATIONS

### 10.6.1 BILL OF MATERIAL

The Bill of Material (BOM) is an engineering data base, which lists all the raw materials, assemblies, and parts that make up the manufactured product or a parent item. In addition to listing the items, the Bill of Material also indicates the quantity of items that comprise the finished goods.

Essentially, BOM provides the structure and content of each parent item or final product. BOM also controls the engineering changes. It will usually interface with the Inventory control, Material Requirements Planning and Cost Accounting modules for effective manufacturing control. The interface to the inventory control module indicates the material requirements for manufacturing orders. The interface with material requirements planning supports the actual material requirements planning and the interface with cost accounting provides the data for costing.



**Fig. 10.9 Bill of Material Module**

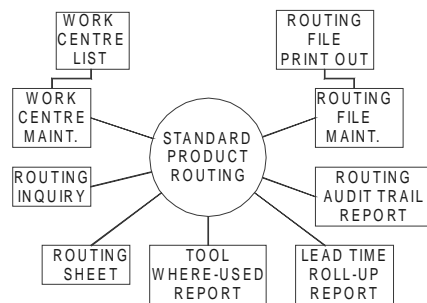
The Bill of Material Processor module does the following functions: (Refer Fig. 10.9)

- Creates audit trails for the product structure file to provide a record of additions, changes, and deletions.
- Allows full product structure file maintenance with user assigned sequence of components.
- Supports up to several levels of sub-assemblies.
- Creates new bills by copying parts of old ones.
- Replaces all occurrences of an obsolete item with a replacement part.
- Allows inquiry terminal to see in which assemblies an item is used.
- Displays the indented or single level bill of material for any item on the screen.
- Prints the total component cost of items in the costed Bill of Material.
- Prints a picking list to facilitate creating kits for assembly.
- Allows reports to be displayed on the screen for immediate inquiry.

**10.6.2 STANDARD PRODUCT ROUTING**

The Standard Product Routing (SPR) package interactively handles the creation, maintenance, and reporting of data describing operations, notes, tools, and outside processes used in product manufacturing. Standard product routing does the following tasks: (Ref. Fig. 10.10)

- Pinpoints desired information by accepting user-specified parameters.
- Accesses assemblies by item number or partial description.
- Maintains labour and machines for the estimated or standard hours for each operation.
- Provides for both primary and alternative routings for each inventory item
- Supports a variety of operation types including production, set up, inspection, move, rework, and etc.
- Provides tooling control information
- Maintains estimated or standard hours on a per piece basis or as an example, per 100 piece basis.

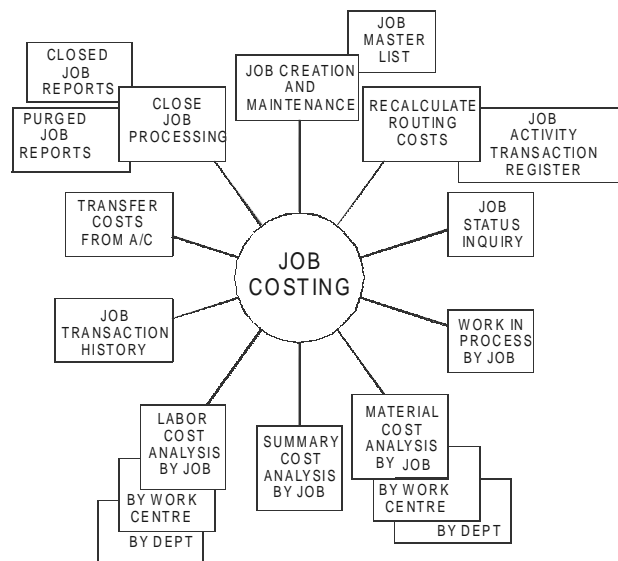


**Fig. 10.10 Standard Product Routing**

### 10.6.3 JOB COSTING

Costing is an important aspect of manufacturing and this module does the costing function. This module performs the following functions: (Fig. 10.11)

- Estimates job costs.
- Supports multiple shop orders in each job.
- Calculates variable and fixed burden costs.
- Displays up-to-date job status information.
- Creates entries for direct labour, material, outside processing, variable and fixed costs, work-in-process (WIP), and finished goods transactions.
- Identifies areas of excessive variance from estimates, for effective cost control.
- Decides areas of excessive variance from estimates, for effective cost control.
- Decides labour cost variances into labour rate, performance and quantity.



**Fig. 10.11 Job Costing**

### 10.6.4 STANDARD PRODUCT COSTING

The Standard Product Costing (SPC) package accurately maintains standard or estimated costs for both manufacturing and accounting management. It also records current and projected costs for all products, parts, and services provided by a company. SPC provides the following capabilities: (Fig. 10.12)

- Supports both beginning-of-the-year (standard) and up to date actual (current) costs.
- Maintains value added costs at each level of the bill of material and builds up total costs from lower levels of the bill of material.

- Separates both standard and current actual figures into man hours, material, and labour, outside processing, and variable and fixed burden for each operation on each item’s primary routing.
- Provides costed bill of material reports in single level, indented, and summarized formats.
- Facilitates “what-if” cost analysis.
- Highlights purchased material costs that deviate excessively from standard costs.

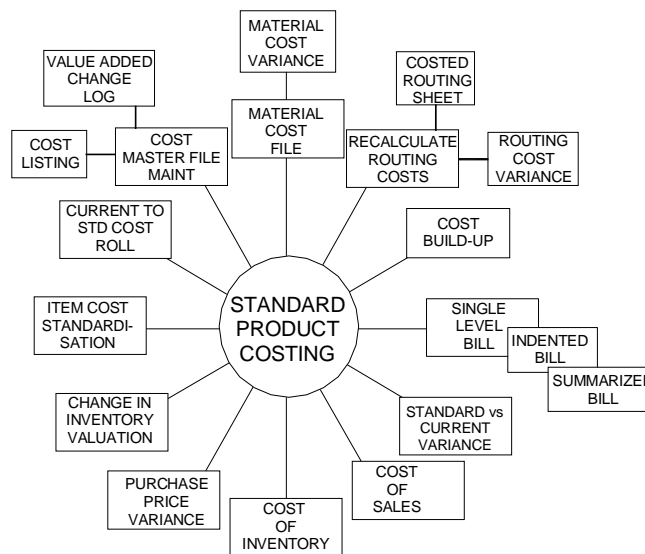


Fig. 10.12 Standard Product Costing

## 10.7 FINANCIAL APPLICATIONS

Although purchasing and cost accounting are considered typical financial applications, they are included in the manufacturing applications because of the close interrelationship between those modules and the typical modules related to manufacturing processes, such as Material Requirements Planning, Master Production schedule, Inventory Control, etc. with which they interface. It is quite reasonable that the traditional financial applications such as accounts payable, accounts receivable, general ledger, fixed assets, and some other ancillary functions are also integrated with the manufacturing system. Many software vendors today integrate the financial modules with the manufacturing process modules - a very desirable feature in the closed-loop MRP-II environment.

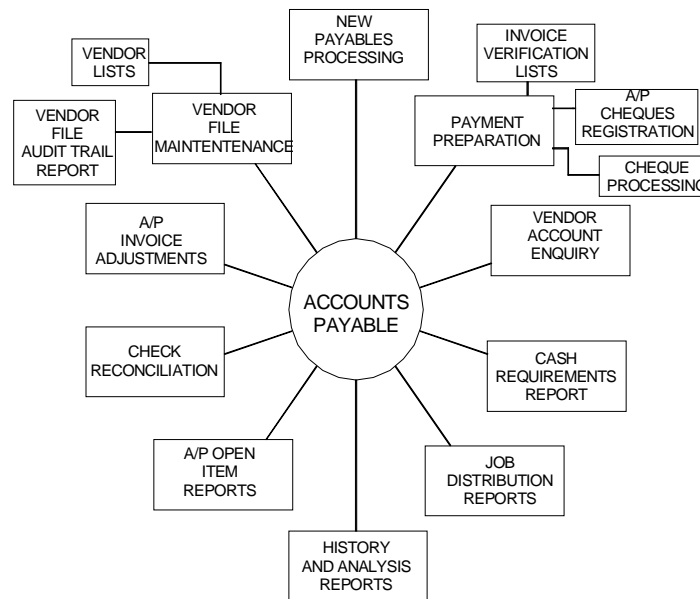
### 10.7.1 ACCOUNTS PAYABLE (AP)

In a manufacturing environment, it is important to balance payment cycles in order to assure continued, on time delivery. With the increasing use of JIT manufacturing,

the close relationship with suppliers requires that timely payments be made. The integration of the accounts payable software with the manufacturing components allows generation of vouchers based on purchase orders recommended in material requirements planning. Integrating AP with the purchasing module can provide an invoice matching process to accurately manage cash flow and to guarantee accurate payment for the received material. Many accounts payable softwares provide history reports on vendors, payments, and discounts taken, which are essential for accurate cost control. (Fig. 10.13)

Normally AP module shall have the following capabilities:

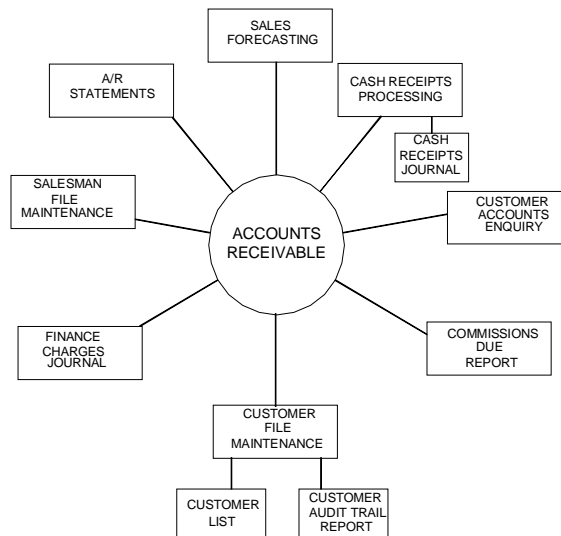
- Accesses vendors by number or name.
- Allows entry and editing of payments to be made, recurring expenses, adjustments, corrections, and manual payments, and prints the AP transaction register.



**Fig. 10.13 Accounts Payable**

### 10.7.2 ACCOUNTS RECEIVABLE (AR)

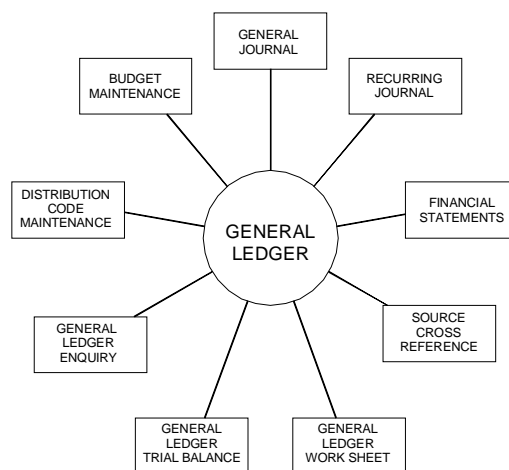
The accounts receivable (AR) function must provide complete credit and collection management facilities. Credit lines should be carefully controlled. The inclusion of a credit history function is necessary in order to estimate receipts and to accurately manage cash flow. Many accounts receivable functions are integrated with order processing or order management function of an MRP system. This AR integration provides immediate credit checking, which ensures that before an order is accepted, the customer's line of credit is satisfactory. (Fig. 10.14)



**Fig. 10.14 Accounts Receivable**

**10.7.3 GENERAL LEDGER (GL)**

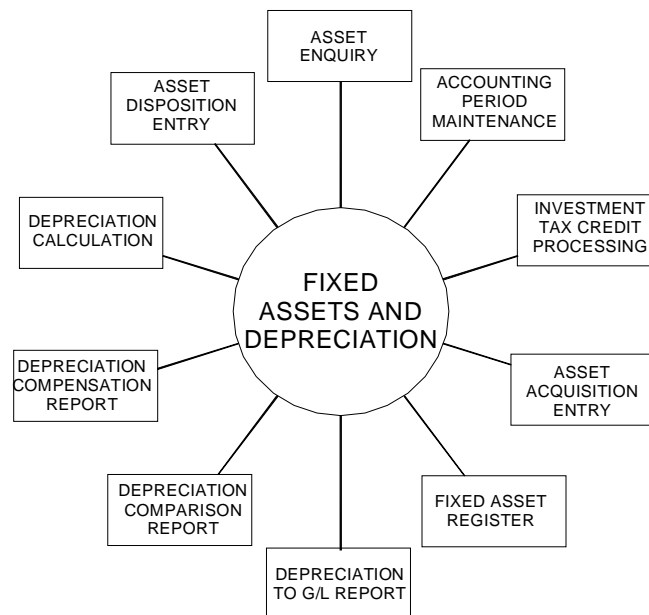
Because of the large number of transactions in manufacturing control, systems integrate the accounts payable and accounts receivable functions with the General Ledger (GL). Many systems also integrate the payroll functions with General Ledger. Most general ledger systems should provide a complete audit trail of all general ledger transactions. Many GL systems today also support the downloading of financial data from the General Ledger to a spread sheet residing in a PC, which allows local data manipulation and forecasting, more efficient department budget preparation, and “what-if” analyses. (Fig. 10.15)



**Fig. 10.15 General Ledger**

### 10.7.4 FIXED ASSETS AND DEPRECIATION

The Fixed Assets (FA) component of an MRP system is essential in a manufacturing environment in order to manage a company's depreciable, non-depreciable, and leased assets from acquisition to transfers and finally to retirement. The Fixed Assets module should accommodate a wide variety of depreciation schedules and techniques to enable the manufacturing company to effectively manage its capital equipment inventory. It should also provide a tracking mechanism for capitalized costs and leases, and leasehold improvements. Since depreciation schedules are usually long, and since many times the depreciation tax law changes while equipment is still being depreciated, the FA component should be able to accommodate changes in the tax laws. (Fig. 10.16)



**Fig. 10.16 Fixed Assets Depreciation**

### 10.7.5 PAYROLL

The payroll function in an MRP manufacturing control system is usually integrated with the General Ledger module and, in some systems with a Personnel Module or with the Cost Accounting function of the manufacturing module. Most payroll modules should accommodate user-defined deduction types and maintain deduction formulae. They usually have tax tables for central, state, and local taxes. The interface with the cost accounting component allows the payroll module to generate and monitor time records and issue payment based on number of days worked including overtime. (Fig. 10.17)

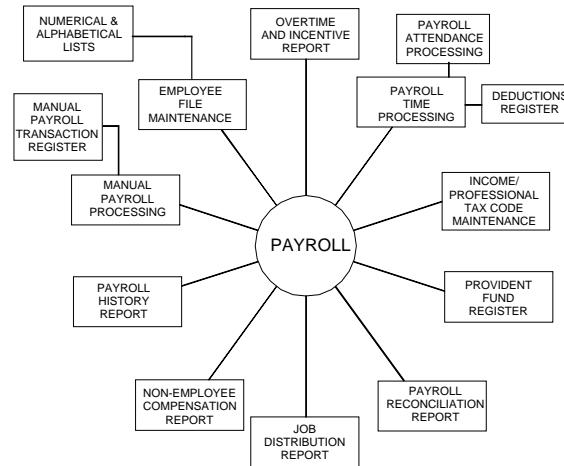


Fig. 10.17 Payroll

## 10.8 MARKETING APPLICATIONS

The final functional element in most current systems is marketing, which includes order entry and sales management, plus activities such as distribution planning.

### 10.8.1 CUSTOMER ORDER PROCESSING

The order entry and order management functions are designed to facilitate both production scheduling from an internal manufacturing perspective and tracking from a marketing and sales-oriented perspective. From a manufacturing perspective, orders are entered for make-to-stock manufacturing in the order processing and Master Production Schedule module to schedule the product. (Fig. 10.18)

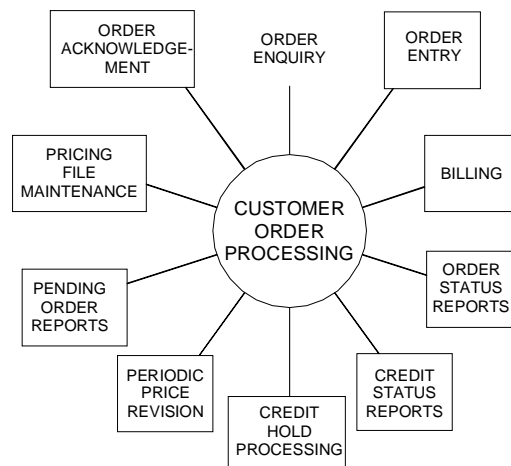


Fig. 10.18 Customer Order Processing



Some systems provide an on-line mechanism, which allows user to review the production schedule and promise customers actual shipping dates based on the product completion date. Order entry also tracks finished goods inventory, and places goods on inventory hold. These procedures not only facilitate the internal production functions, but also provide better customer service. Most order processing modules also support customer credit checking, available inventory, generation of quantity-price estimates, and audit tracking. The data from the order management function aids sales analysis by indicating trends in products, customer purchases, and sales performance.

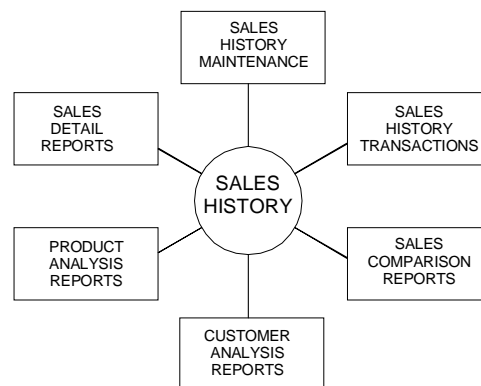
### 10.8.2 SALES HISTORY

Since many manufacturers deal with customers through dealers, distributors, or manufacturer's representatives, the sales management function should accommodate each of these sales channels. Since some MRP systems integrate the sales management functions with the payment of sales commissions, an interface to the payroll module is essential.

The calculation of commission and tracking is an important tool to aid sales monitoring and sales analysis. When the sales management function is integrated with the order processing function, sales quotas and performance data can be derived from the movement of data through the system. This procedure aids in sales analysis by providing sales by product type and by sales person. It can also provide historical data to analyze budgets and forecasts. (Refer Fig. 10.19)

Sales history software provides the following functionalities:

- Obtains data automatically when invoices are printed and optionally allows manual entry.
- Prints sales analysis reports by customer, customer type, customer sales volume, salesman, state, territory, item sales volume, and product category.
- Prints sales comparison reports by customer, customer and product; product and customer, product category and product; and salesman, customer and product.
- Prints sales detail reports by territory by customer, salesman, state, product category, and invoice date.



**Fig. 10.19 Sales History**

### 10.8.3 DISTRIBUTION PLANNING

Some MRP-II systems also provide a distribution resource planning function, which interfaces with master production schedule to establish safety stocks and calculate replenishment order quantities. This package is designed to monitor inventory levels and distribution resources, such as warehouse space, with the purpose of reducing inventory levels while maintaining customer service levels.

## 10.9 MISCELLANEOUS APPLICATIONS

### 10.9.1 LABOUR PERFORMANCE

Labour performance is a vital tool for identifying productivity problems and improving labour utilization. It provides for easy and efficient entry, editing, tracking, and reporting of employee labour performance statistics and earnings. This package has the following functions: (Refer Fig. 10.20)

- Separates labour into direct and indirect categories.
- Tracks employee attendance through payroll attendance records which are used to calculate payroll.
- Provides for incentive pay.
- Supports time card processing.
- Prints the labour performance history report, providing data to help the user analyze each employee's performance and productivity.
- Reports on permanent and casual employees as well as incentive earnings.
- Supports group incentive performance rates.
- Provides for the entry for regular, overtime, and special wages.

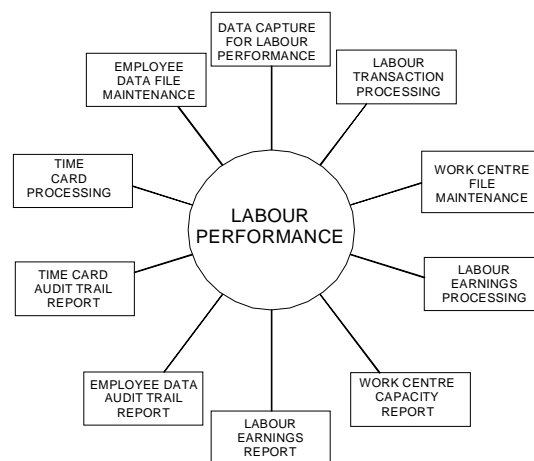


Fig. 10.20 Labour Performance

### 10.10 COMMON ACRONYMS USED IN AN MRP-II ENVIRONMENT

AP (A/P)	-	Accounts payable
AR (A/R)	-	Accounts Receivable
BOM (BOMP)	-	Bill Of Material(S) (Bill of Material(S) Processor)
CRP	-	Capacity Requirements Planning
DRP	-	Distribution Requirements Planning
FA (F/A)	-	Fixed Assets
GL (G/L)	-	General Ledger
IC (I/C)	-	Inventory Control
JIT	-	Just in Time Manufacturing
MPS	-	Master Production Scheduling
MRP	-	Material Requirements Planning
MRP-II	-	Manufacturing Resources Planning
OE (O/E)	-	Order Entry
OP (O/P)	-	Order Processing
PAC	-	Production Activity Control
PR (P/R)	-	Payroll
PO (P/O)	-	Purchase Order
RRP	-	Resource Requirements Planning
SFC	-	Shop Floor Control

### 10.11 STATUS OF MRP-II SOFTWARE

Many vendors advertise their manufacturing control system as “the cornerstone of CIM system”, and feature state of the art interfaces and modules. Many manufactures, however, are still struggling with too much inventory and incorrect bills of materials; they are not yet ready for the factory of the future. It must be stressed that MRP-II, or CIM, or JIT alone will not solve all manufacturing problems. Putting the problems on a computer will only automate the solution.

First, manufacturers should identify and begin to solve their problems while implementing a good, basic MRP-II. This may involve a year or two of updating their bills of material to reflect the real world, reducing inventories, and cutting lead times. They

can then gradually introduce basic just-in-time (JIT) techniques, such as having a good relationship with one or two reliable suppliers, reducing lot sizes, and implementing total quality control programs.

Surprisingly, many manufacturers are just now discovering that their employees are a great resource which they have all along virtually ignored. Sadly, some manufacturers are yet to discover it. No one knows where the waste and inefficiency exists better than people on the shop floor. Nobody else is in a better position to suggest ways to stop it. The Japanese discovered this, and used this in quality circles and total quality control (TQM) to correct the design and manufacturing problems. The immediate future of manufacturing in India depends on getting employees more and more involved in the decision making and quality of the products. To do this uphill task, top management has to get involved, delegate some of their powers, and let employees know that they can make a difference.

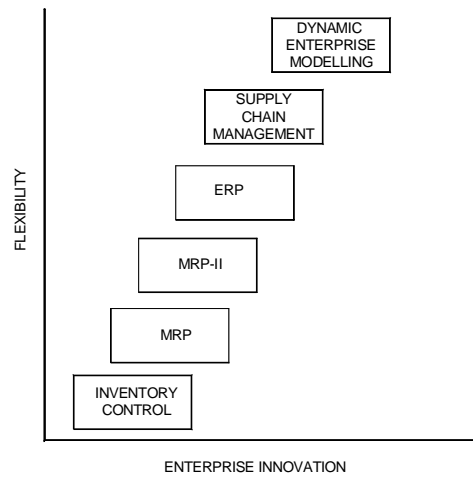
In the long run, the adoption of JIT is inevitable. To be competitive, Indian manufacturers must reduce their lead times, become more flexible to satisfy a rapidly changing market, and institute better quality control methods—all the hallmarks of JIT.

In the past, vendors advertised systems that were upgradeable to larger systems. Today, more and more software vendors are realizing the importance of personal computers in the office and industry environment. Most offer some facility to download information collected through the MRP system to PCs for use in spreadsheets and reports.

This trend towards smaller, distributed (but linked) systems will continue. With the incredible power and ease of use of today's mini and personal computers, one will be seeing fewer mainframe installations and more minicomputers and networking of personal computers. PC's, unlike mainframes (and to some extent minis), do not require an extensive MIS department. PCs can be used independently for word processing or data manipulation while still being tied into a network with a central file server. Networked systems can expand or shrink to fit the needs of the company.

## **10.12 DYNAMIC ENTERPRISES**

Global competition forces manufacturing companies to constantly strive for improvement in quality and reduction in price and product development time. The manufacturing companies, therefore, are always on the look out for strategies which will help them to achieve these objectives. During the last few decades, the focus of the manufacturing strategy has been shifting from one innovation to another in order to improve the flexibility which is essential for supplying products, which meets the satisfaction of customers. These innovations are shown in Fig. 10.21.



**Fig. 10.21 Evolution of Planning Strategies**

Initially the companies used to concentrate on inventory control. Later, material requirements planning (MRP) was the strategy for improving the companies' performance. MRP was followed by MRP-II. At this stage, the planning of various resources of manufacture was all tied together under the umbrella of IT. The closed-loop MRP-II provided solutions to all enterprise resource planning problems. MRP-II however could not completely meet the requirements of companies. Enterprise Resource Planning or ERP and subsequently, advancement on ERP, dynamic enterprise modeling evolved. MRP-II is a subset of the present day approach to manufacturing planning. The subsequent section in this chapter is devoted to the discussion on these topics.

### 10.13 ENTERPRISE RESOURCE PLANNING (ERP)

Enterprises to-day employ a mixture of several approaches to manufacturing. They include:

- Make to stock
- Design to order
- Make to order
- Assemble to order

It must be possible to operate the company in all these modes. The emerging trend of amalgamations, acquisitions and strategic alliances among competing corporations required more capable software to manage such multi-facility enterprises. Another challenging task is the co-ordination of manufacturing in facilities which are geographically dispersed. For example, a multinational company will have divisions and subsidiaries in U.S.A, Canada, UK, India, Germany, Korea and Japan. An Indian multinational company may have plants in Poland, Belgium and UK. Each country will have its own currency and tax laws. This requires multi currency functionality for the planning software. The need for managing

the entire enterprise within a more global, tightly integrated closed-loop solution has led to the evolution of ERP software.

The core activity in ERP is the creation of an integrated data model, covering employees, customers, suppliers etc. A distinguishing feature of the ERP software is that it incorporates best practices. This means that the manufacturing solution developed using ERP is an optimum one.

The implementation of an ERP system includes the following stages:

- i. Definition of the scope of the project
- ii. Identification of the objectives and deliverables
- iii. Project organization
  - Identifying an executive responsible for successful implementation of ERP
  - Establish a senior management steering committee
  - Establish a project team
  - Define the role of consultants
- iv. Work plan development
- v. Assessment of the business of the company - where it is to day and where it should go
- vi. Education of key managers
- vii. Cost/benefit analysis

### 10.13.1 MODULES IN TYPICAL ERP SOFTWARE

The important modules in typical ERP software are:

#### i. Finance Module

The finance module extracts financial transactions from the sales and manufacturing areas and posts them to the general ledger. The main elements of finance module are:

- General ledger
- Accounts payable
- Accounts receivable
- Cash management
- Fixed Assets
- Financial statement
- Budget
- Cost allocation

#### ii. Distribution Module

This module manages finished goods, raw materials and services. Sales orders are managed by this module. Inventory control, location control, Distribution

Requirements planning and replenishment control are part of distribution module.

***The business objects of this module are:***

- Item control
- Cost accounting
- Purchase control
- Sales control
- Sales and marketing information
- Electronic data interchange
- Replenishment order control
- Inventory control
- Lot control
- Location control
- Distribution requirements planning

**iii. Manufacturing Module**

This module is designed to control all the operations related to manufacture. The business objectives of this module are:

- Engineering Data Management
- Item control
- Bill of materials
- Routing
- Master production schedule
- Materials requirement planning
- Capacity requirement planning
- Repetitive manufacturing
- Shop floor control
- Hours accounting
- Project budget
- Product configuration and classification
- Project control
- Quality management

**iv. Service Module**

Service module deals with repair and warranty related activities. The functions of this module are:

- Installation control
- Contract control
- Service order control

Service analysis control

**v. Transportation module**

*The functions of this module are:*

- Employee control
- Address control
- Fleet management
- Fuel control
- Hours and expense control
- Transport control
- Packing control
- Warehouse control

**vi. Process Module**

The process module helps companies to keep track of the manufacture of products.

**vii. Project Module**

The project module consists of

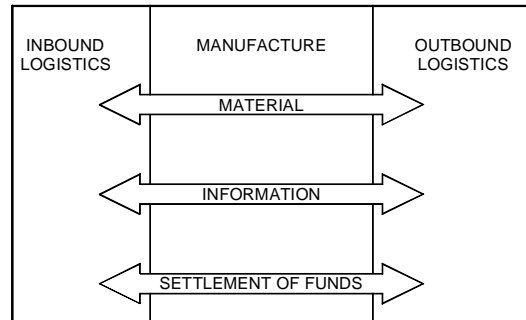
- Estimating
- Definition
- Budget
- Planning
- Requirement
- Progress
- Monitoring
- Invoicing

**viii. Tools Module**

Tools Module covers the following:

- Software installation
- Application configuration
- User management
- Device management
- Job management
- Database management
- Audit management
- Text management
- Menu management
- SQL queries
- Application development and customization
- Documentation





**Fig. 10.22 Supply Chain**

#### **ix. Utilities Module**

The utilities module is used to import and export data among different ERP systems.

#### **Other Modules of ERP packages are:**

- Materials management
- Supply chain management
- Quality management
- Human resource management
- Plant maintenance
- Treasury

### **10.14 SUPPLY CHAIN MANAGEMENT**

Most products involve procurement and sourcing of raw materials (in bound logistics). Manufacturing involves processing and assembly functions (conversion). The finished goods are packaged, stored and distributed to the customers (outbound logistics). The supply chain management is the task of coordinating this chain. This is shown in Fig 10.22.

Timely supply of materials and components has always been a major source of worry for manufacturers. Supply chain management has a global scope and covers opportunities prior and post manufacturing. Supply chain management has become significant as corporations are beginning to view their business and their partners (vendors and customers) as an end-to-end network. Like any network, this manufacturing network has tremendous opportunities for optimization. Thus supply chain management becomes a technology driven activity which encompasses several new concepts that have now become commonly accepted in manufacturing. Some of them are briefly mentioned here.

- Vendor Managed Inventory (VMI) is an arrangement between distributor and manufacturer that places the responsibility of replenishment on the supplier.

- Advanced planning and scheduling (APS) is a planning approach that balances demand, production planning, manufacturing, distributor and other supply chain elements. This synchronizes the entire supply chain resources.
- Efficient consumer response (ECR) is an association of retailers and manufacturers which shares information about electronic data interchange (EDI) like invoices, point-of-sale detail and package labeling standards. Vendor managed inventory is one of the techniques that fall under ECR activities.

Supply chain management is a collection of information technology tools, processes, organization and performance measurements that are properly aligned to eliminate excess inventory so that suppliers, customers and manufacturers benefit from cost minimization.

Supply Chain management is the integration of procurement, logistics, planning, forecasting and transportation. The focus of supply chain management changes from industry to industry. In aerospace industries, the supply chain strategy has to take into account the complex and long cycle time fabrication and low volume subsystems. In the case of automotive industries one has to consider multi-step high volume lines and factory capacity and production scheduling are important factors. Customer preferences play an important part in consumer electronics, semi-conductors and domestic appliances area. The supply chain management in this case is heavily vendor oriented. However, efficient retailing is no less significant. Procurement cost in these industries is a substantial portion of total cost. On the other hand, in heavy industries, manufacturing cost and labour cost form a significant portion of product cost.

A second focal point of supply chain management is often the necessity to getting the product early to market. Here, in the early production period, manufacturing efficiency may not be accorded priority.

Distribution oriented supply chain is the third focal point of supply chain management. Products like petroleum oils the factors to be considered are the replenishment and transportation of finished products. The emphasis here is on market share and shelf space in retail outlets. To-day’s manufacturing scenario is pictorially represented in Fig. 10.23.

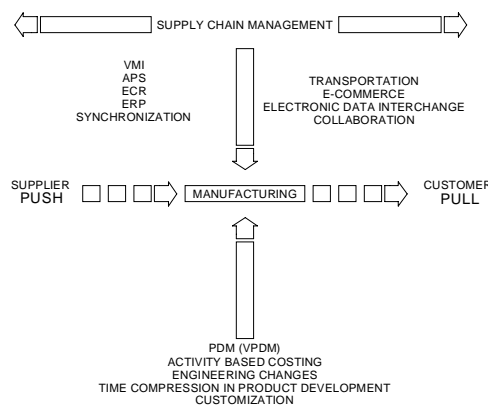


Fig. 10.23 Manufacturing Scenario

Manufacturing is subjected to the supplier push at one end and client pull at the other end. The supplier is required to ensure synchronized direct-line delivery. That means no storage of parts in manufacturer's works. Instead of components, value-added sub-assemblies are preferred. The practice of concurrent engineering enables the supplier to participate in the configuring of the product and hence uncertainties in component design and costing are eliminated. The lot size of items delivered is small, necessitating more frequent deliveries. At the customers' end, lot sizes are small because of customization. There are more frequent design changes to accommodate customer's needs and deliveries are synchronized with the requirements. For efficient manufacturing, there is more emphasis on the use of product data management Softwares, activity-based costing, frequent engineering changes and short product development life cycles. The supply chain management system is the enabling technology across this chain.

### **10.15 VIRTUAL MANUFACTURING**

The concepts of downsizing and outsourcing are changing the manufacturing scenario. In a virtual manufacturing scenario, the manufacturing companies need not own a manufacturing facility. From a supply chain perspective the functions of the chain can also be satisfied through a contract relationship. A virtual enterprise is a corporate business model that creates a supply chain for a product but does not use in house manufacturing facility. What is required is a strong development team and partners to supply parts, a contract firm to manufacture and a sales / distribution partner. The capabilities of a team of expert supply chain partners are leveraged to carry on with a particular business process.

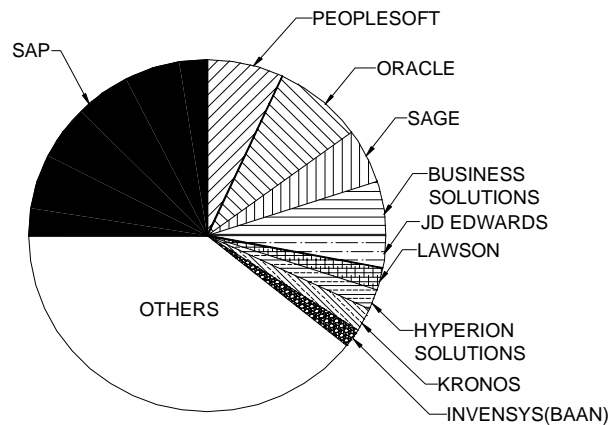
### **10.16 SELECTION OF AN ERP PACKAGE**

There are several criteria for the selection of an ERP package. They are:

- Suitability of package to operations
- Better functionality offered by package
- Better compatibility with existing applications
- Availability of better technical support
- Fewer time frames for implementation
- Less customization effort required
- Better price
- Recommendation of consultants
- Experience on the use of same package in similar industries
- High vendor reputation
- Better sales support
- Affordability

### 10.17 ERP IN INDIA

Figure 10.24 shows the approximate market share of various ERP packages in 2002. Since then there have been several changes in the status of the companies. Some of the ERP vendors have acquired their competitors.



**Fig. 10.24 Market Share of Various ERP Packages**

### 10.18 DYNAMIC ENTERPRISE MODELLING (DEM)

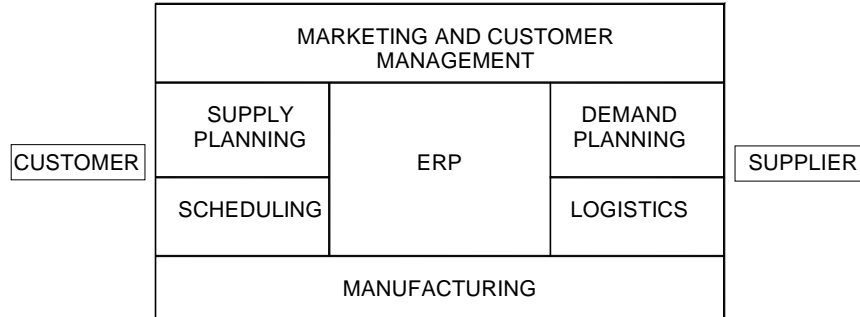
In the last 30 years, the whole basis of international competition and determinants of competitive advantage have changed. Until the sixties, the emphasis was on increasing the volume of production. The seventies were distinguished by the emphasis on improving quality. During eighties, the increase in production capacity forced manufacturers to offer wider range of products.

The international competition became very complex in the 1990's forcing the manufacturers compete on price, quality, innovation, delivery time, customization and service. The situation today is such that new industries today can be located anywhere depending not so much on where natural resources are located, but where the market growth is happening and where brain power and practical skills can be better utilized. The emergence of China as a manufacturing giant is thus significant.

The development of IT has changed manufacturing scenario completely. Customers now demand higher degrees of sophistication in marketing, layout and design of goods, packaging, etc. Warehousing, stock control, cash balancing and ordering employ new technologies. Electronic point of sales systems and bar coding facilitates automatic cash and inventory recording. The shop floor scenario has changed with the introduction of many flexible manufacturing systems. Behind these entire developments one could detect the ever-growing functionality of the software to meet the market pressures.

The concept of dynamic enterprise modeling was developed to assist the manufacturers to bridge the gap between IT and real world of users. This enables companies to improve the processes by which they conduct the business.

The model of dynamic enterprises can be represented as shown in Fig. 10.25.



**Fig. 10.25 Dynamic Enterprises**

ERP is the core of internal supply Chain. An extended supply chain management system encompasses the suppliers and customers. The dynamic enterprise modeling covers:

- Business process analysis and improvement
- Identification of opportunities and requirements
- Translating strategy to activities
- Impact analysis of changes
- Business process modeling
- Identification of IT needs and solutions
- Workflow management

The purpose of modeling a firm as a dynamic enterprise is to derive benefits in cost, quality and time. This could be achieved with the right use of IT.

## QUESTIONS

1. Discuss the importance of software in the efficient planning and management of manufacturing operations.
2. Make a study of the impact of Toyota Production System concept in Indian manufacturing.
3. Compare pull system and push system of manufacturing
4. Discuss how the inventory control concept gradually evolved into present day dynamic enterprise modeling.
5. Discuss how the computer networking facilitated planning operations in engineering manufacture.

6. Describe the major modules of MRP software.
7. Why is master schedule important? How does master schedule accommodate flexibility in manufacturing?
8. What are the important sub-modules of a materials requirements planning software?
9. What is the significance of capacity requirements planning in the context of globalization and outsourcing?
10. How does shop floor monitoring help in meeting delivery schedules?
11. Discuss the inventory management vis-à-vis just in time manufacture.
12. Discuss the various modules of purchase management software.
13. What is the significance of bill of materials?
14. What are the different financial and accounting modules of the manufacturing information systems?
15. Why is enterprise resource planning a holistic approach to manufacturing planning?
16. Discuss the scenario of implementation of ERP in Indian manufacturing industries.
17. What is meant by a virtual enterprise?

**This page  
intentionally left  
blank**

# MANUFACTURING AUTOMATION

*One of the major developments that led to CIM was the introduction of computer control of manufacturing equipment and operations. Till the advent of microprocessors and personal computers, manufacturing automation was mainly through the so-called hard automation through hydraulic, pneumatic or electric methods. Programmable logic controllers (PLC) have now become a very convenient tool for flexible automation. PLC's are widely used in pneumatic, hydraulic, electric, and electronic automation. CNC machine tools, robots, transfer machines, industrial drives etc. use PLC's. This chapter introduces the readers to the concepts of low cost automation as well as automation using PLC's through simple application circuits.*

## 11.1 INTRODUCTION

Apart from the soft data processing aspects of automation like what was discussed in chapter 10, manufacturing involve machinery and equipment to shape raw materials to parts of desired geometry. Manufacturing processes like casting, welding, forming of sheet metals and tubes, extrusion, injection molding, spinning, drawing, forging, rolling, cutting, machining, lithography, assembly etc involve different kinds of machinery and equipment. Automation involves not only carrying out the manufacturing process without human intervention but also many connected operations like stock feeding, proper sequencing of various steps involved in manufacturing, removal of the processed part from the machine or equipment, measurement of the completed part and the removal of swarf and lubricants. For example, in a pressure die casting operation, the molding machine may be hydraulically operated while the molten metal may be automatically transferred from the melting furnace to the injection chamber. The cast part is automatically picked up after the separation of the dies and the parts are cooled and trimmed. Automation is employed to lubricate the dies, cool the dies after part removal etc. Sensors are employed to measure injection speed, shot rod position, hydraulic pressure and other data required to adjust process parameters not only to ensure castings of consistent quality, shot after shot but also to collect performance data for statistical analysis for quality assurance purposes as well as future process improvement.



Similarly, if one considers the welding operation, welding operations like spot welding could be easily automated. In arc welding, the extent of automation is such that the entire welding activity including electrode feeding, manipulating the work piece, seam tracking etc requires hardly any human intervention.

Manufacturing automation is not limited to metal processing alone. Textiles, semiconductors, chemicals, plastics processing etc today employ very high level of automation, lending themselves to integration leading to a CIM system. This chapter and as many of the subsequent chapters are devoted to automation of hardware.

Mechanization preceded automation in manufacturing. Mechanization involves providing human operators with machinery to assist them with the physical requirements of the work. For example, a chip conveyor eliminates the need for operator to remove the chips from the cutting zone in lathe operations. A hydraulic chuck facilitates quick and easy clamping of work pieces. An automation system eliminates the need for human sensory inputs and decision making and makes the manufacturing system autonomous.

Semiautomatic and automatic machines were introduced in the early stages of manufacturing. Mechanical control by cams was widely employed before the advent of electrical control using limit switches and plug board control. Hydraulic tracer control was also popular in machining. The advent of the computer era introduced several types of automation systems one after another. Information input by punched cards was followed by punched tape. Sophisticated data acquisition systems facilitated the automation of process control systems. Transfer lines using a combination of mechanical, electrical, pneumatic and hydraulic automation was introduced by automobile industry. The developments in semiconductor industry and entertainment electronic industry necessitated sophisticated automation equipment and robots. Another compelling reason for automation is the need for maintenance of consistent quality as human operators are subject to fatigue, which reduces their concentration, which often has an adverse effect on quality. Automation also increases productivity.

## 11. 2 TYPES OF AUTOMATION SYSTEMS

Automation systems can be classified into three major types:

- i. Pneumatic automation
- ii. Hydraulic automation
- iii. Automation systems using programmable logic controllers, which involve combinations of the above.

These are briefly discussed in the subsequent sections.

### 11.2.1 PNEUMATIC SYSTEMS

Many low cost automation systems are based on air-operated devices. Most of the manufacturing shops will have pressurized air supply for clamping, cleaning etc. This

could also be used as an energy source for automation purposes. This could keep the cost of automation low and hence this type of automation is also called low cost automation. The actuators are the air motors for rotary motion and pneumatic cylinders for linear motion. A wide variety of motors and cylinders are available for a variety of applications. Cylinder types include pneumatic, electrical and servo pneumatic. Direction control valves control the direction of motion of the actuator. Several other types of valves are also used in designing pneumatic systems for automobile, general engineering, biotech and pharmaceutical industry, electronics, food processing and beverage industry etc. The components of the pneumatic systems also include air preparation units, positioning units, vacuum systems, handling systems, control valves, valve terminals, sensors, image processing systems, and tubing and tubing connections. Figure 11.1 shows a typical range of pneumatic components used for automation.



*Fig. 11.1 Pneumatic Automation Components (Courtesy: FESTO)*

### 11.2.2 OIL HYDRAULIC SYSTEMS

Hydraulic systems have a significant advantage over pneumatic systems in their ability to handle higher loads and torques. Hydraulic oil is also practically incompressible. Hydraulic systems operate at significantly higher pressures ranging from 35 Mpa to 200 or more Mpa. This reduces the size of the actuators. Hydraulic systems require a power pack to supply pressurized oil of adequate quantity. As in pneumatic systems, the actuators are either motors or cylinders. The muscle power of hydraulic systems combined with the flexibility and ease of electrical and electronic control makes electro hydraulic systems an obvious choice even for very demanding applications. Industrial hydraulic systems use a wide variety of components like cylinders, rotary actuators, pumps, valves for the control of flow direction, volume, pressure etc, accumulators, filters and tubing.

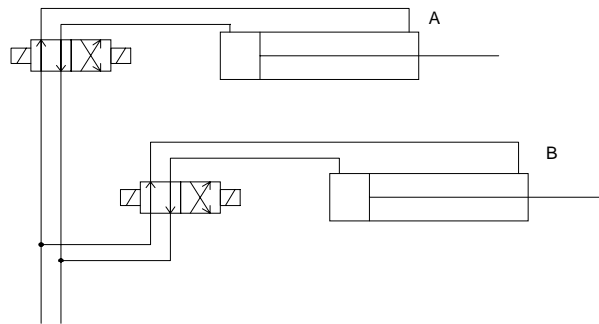
### 11.3 PROGRAMMABLE LOGIC CONTROLLERS

Industrial control circuits are designed to serve several functions:

- i. **Switching:** It is necessary to switch on control elements to operate actuators like hydraulic cylinders, electric motors, pneumatic valves etc. For example, a pneumatic or hydraulic cylinder may be used to actuate the door closing function in a CNC machine.
- ii. **Sequencing:** Certain functions in machines should be performed in a particular order. For example, if two cylinders, shown in Fig. 11.2 are to be operated in sequence, the sequence may be any one of the following:

A	B	B-	A-
A	A-	B	B-
A	B	B-	A-
B	A	A-	B-
B	B-	A	A-
B	A	B-	A-

“- “ Symbol denotes the movement of the cylinder in the reverse direction.



**Fig. 11.2 Two Cylinders in Sequence**

For example, the sequence ABB-A- means:

- Cylinder A moves forward first
- Cylinder B moves forward next
- Cylinder A retracts and then
- Cylinder B retracts

- iii. **Process Control:** A PLC may be used to control a process on the basis of signals received from a process. The signals may be analog or digital.

PLC is a microprocessor-based unit that carries out control functions of many levels and complexity. PLC is used to monitor process parameters in industries and adjust process control parameters on the basis of a built-in logic. It is user-friendly and can be operated by even unskilled persons.

**Typical PLC applications are listed below:**

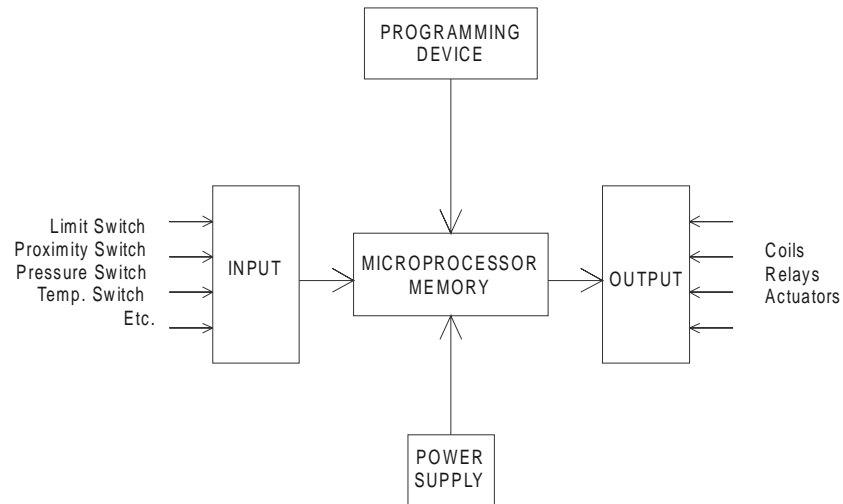
- (a) Switching functions in a CNC machine tool like spindle motor on/off, coolant motor on/off, chuck opening and closing, tailstock forward/reverse, door close/open, guard open/close, pallet change etc.
- (b) Operation of lifts in buildings.
- (c) Control of electric motors in industrial drives.
- (d) Transfer machine control.
- (e) Heating control in process industries.
- (f) Control of traffic signals.
- (g) Safety control of presses.
- (h) Robot control.
- (i) Home and medical equipment.

PLC is widely used because of several of its advantages, some of which are described in the following sections:

- (i) **Flexibility:** A PLC can be used for controlling one machine or a group of machines. A PLC program can be altered easily through a keyboard sequence so that the machine functions can be modified at the will of the designers without incurring additional cost of hardware or scrapping existing hardware.
- (ii) **Low cost:** Technological developments in microelectronics technology have reduced the cost of PLC's considerably.
- (iii) **Speed of operation:** PLC's operate faster than relays.
- (iv) **Security:** A PLC program cannot be altered without unlocking the program.
- (v) **Reprogramming:** In the case of transfer machines the modifications in the control circuit can be carried out by simple reprogramming so that same hardware can be used for a new sequence.
- (vi) **Modularity:** PLC's can be assembled in a modular fashion. The designer can add modules depending upon his requirement of the number of inputs and outputs.
- (vii) **Analog and digital inputs:** PLC can input/output both analog and digital signals.
- (viii) **Correction of errors:** Efficient debugging procedure enables easy error correction.
- (ix) **Off-line programming:** PLC program can be designed off-line and tested before implementation.
- (x) **Boolean programming:** PLC programming can be carried out using a ladder diagram by an experienced technician.
- (xi) **Documentation:** PLC programming devices can generate a printout as soon as the ladder diagram is completed. This avoids the need for separate documentation efforts.
- (xii) **Reliability:** Since PLC is a solid-state device the reliability is very high.
- (xiii) **Maintainability:** The modular nature of the PLC design makes maintenance easy.

## 11.4 PARTS OF A TYPICAL PLC SYSTEM

Figure 11.3 shows the block diagram of a PLC system. It consists of four major parts, which are briefly described below:



**Fig. 11.3 Block Diagram of A PLC System**

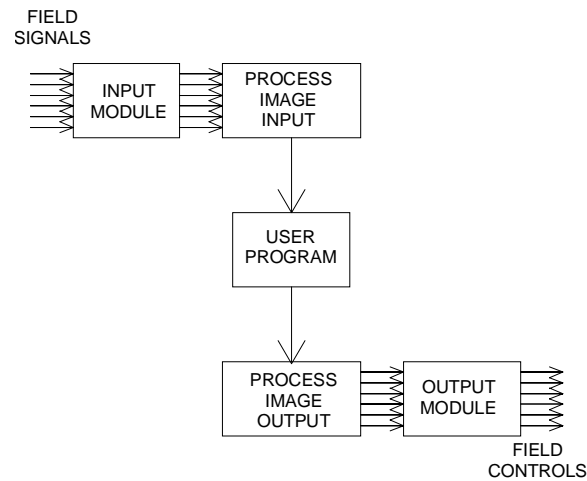
- (i) **The central processing unit (CPU):** Like a computer this is the brain of a PLC. It has several sub-parts.
  - (a) A microprocessor to carry out arithmetic and logic operations.
  - (b) Memory to store data and programs.
  - (c) Process image memory.
  - (d) Internal timers and counters.
  - (e) Flags.
- (ii) **Input module:** This acts as an interface between the field inputs and the CPU. The input module accepts voltage signals from the limit switches, sensors, transducers, proximity switches, push buttons etc. The input signals can be analog or digital. The input module performs four tasks.
  - It senses the presence or absence of input signals at each of its input terminals. The input signal tells what switch, sensor, or other signal is on or off in the operation being controlled.
  - It converts the input signal to a DC level useable by the PLC's electronic circuit.
  - The input module carries out electronic isolation of output from input.
  - It produces an output sensed by CPU.

A typical input module will have 4, 6, 8, 12, 16, or 32 terminals.

- (iii) **Output module:** The output module interfaces the output devices like contactors, lamps, relays, solenoid valves etc. with the CPU. The output module acts in just opposite manner to input module. A signal from CPU is received by the output module, once for each scan. If the CPU signal code matches the assigned number of the module the module is turned on. The output modules will have 4,6,8,12,16 or 32 terminals.
- (iv) **Power supply**
- (v) **Racks and chassis to mount the elements**

## 11.5 OPERATION OF A PLC

Figure 11.4 shows the operational sequence of a PLC. The PLC system software executes the user program. The speed with which the operations are carried out will depend upon the specifications of the microprocessor. The usual method of operation of a PLC is to scan all the inputs, process the user program and then scan all outputs. This is called a scan cycle.



**Fig. 11.4 Operation of a PLC**

## 11.6 PROGRAMMING OF PLC

Entering and storing a sequence of instructions in the memory of the PLC either can be carried out by a hand-held programming device or using a personal computer. The programming can be done either on-line or off-line as desired by the programmer.

### 11.6.1 OFF-LINE PROGRAMMING

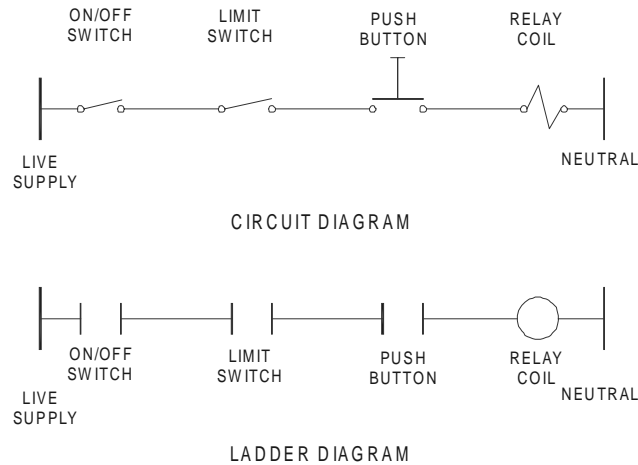
Off-line programming is used to design programs prior to running the machine. This permits the programs to be checked prior to implementation and detect any bug in the program. This is the preferred method of programming.

### 11.6.2 ON-LINE PROGRAMMING

On-line programming is implemented with the direct connection to the PLC. Changes in the program are made when the PLC is in the running mode.

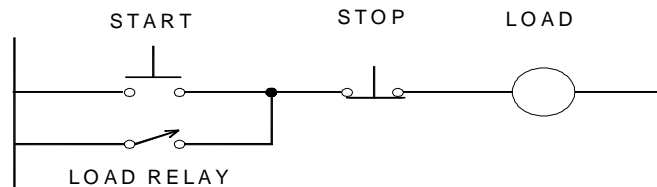
### 11.6.3 LADDER LOGIC

The type programming used for PLC is ladder logic. This is a graphical representation of the hard-wired system used in electrical circuits and includes switches, timers, counters, and many other pieces of hardware in a structured manner. Figure 11.5 shows one rung of a circuit diagram and the corresponding ladder diagram.



**Fig.11.5 One Rung of a Circuit Diagram and the Ladder Diagram**

The left hand of the ladder diagram is the live supply and the right hand is the neutral or common line. The flow of control is from left to right. The operation of the ladder logic can be explained with the help of a simple example of starting an electric motor. Figure 11.6 shows a single rung motor starter circuit.



**Fig. 11.6 Single Rung Motor Starter Circuit**

The activation of the motor will occur when all the input devices on the rung will provide continuity from left to right to the output device. However, this cannot be used

practically. Another path to the motor is needed to keep the motor running. This is shown in Fig. 11.7. When the start button is depressed the motor will start and the relay contact parallel to the start button will close. When the start button is released current will flow through the relay contact until the stop button is pressed. This will open the relay contact and stop the motor. In terms of the Boolean logic the motor will run if:

(Start depressed OR IR relay closed) AND (STOP closed).

Now this can be programmed in the PLC software using contact symbols as shown in Fig. 11.7.

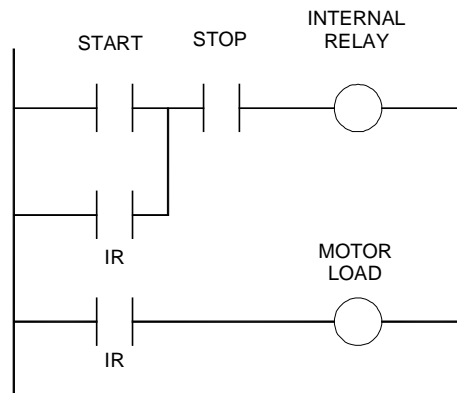


Fig. 11.7 A Two-rung Software Ladder Diagram for Starting a Motor

### 11.7 EXAMPLE OF APPLICATION OF PLC IN A CNC MACHINE

In CNC machines PLC is used for realizing several functions. In some machines PLC is integral with the CNC system. In most of the machines PLC is separate. The PLC program is designed by the manufacturer of the machine to satisfy the specification requirements of the machine. The input/output of a PLC in a CNC lathe is given in Table 11.1.

Table 11.1 PLC Input/Output for a Lathe

I 0.0	-	SMT 40
I 0.1	-	SMT 8
I 0.2	-	SMT 4
I 0.3	-	SMT 2
I 0.4	-	SMT 1
I 0.5	-	T STROBE



I 0.6	-	M STROBE
I 0.7	-	EMERGENCY OUTPUT
I 0.8	-	Z ENABLE
I 0.9	-	X ENABLE
I 0.A	-	JOG OUTPUT
I 0.B	-	AXIS CONTROLLER READY
I 0.C	-	TRK6 SPINDLE DRIVE READY
I 0.D	-	SPINDLE ZERO
I 0.E	-	DRIVES ON
I 0.F	-	BDT/M01
I 10.0	-	BIT 1
I 10.2	-	BIT 2
I 10.3	-	BIT 3
I 10.4	-	TURRET LOCK
I 10.5	-	TURRET MANUAL INDEX
I 10.6	-	CHUCK PRESSURE SWITCH
I 10.7	-	RESET
I 10.8	-	TURRET STROBE
I 10.9	-	GEAR HIGH PROXIMITY
I 10.A	-	GEAR LOW PROXIMITY
I 10.B	-	JOB CLAMP/UNCLAMP
I 10.C	-	CHUCK ID/OD
I 10.D	-	DOOR CLOSE
I 10.E	-	BRAKE OK FFR
I 10.F	-	LUBRICATION PRESSURE SWITCH

The ladder diagram for the machine is shown in Fig. 11.8 (a) and (b). A careful reading of the ladder diagram will reveal that the switching functions are effectively managed by the PLC in a flexible manner.

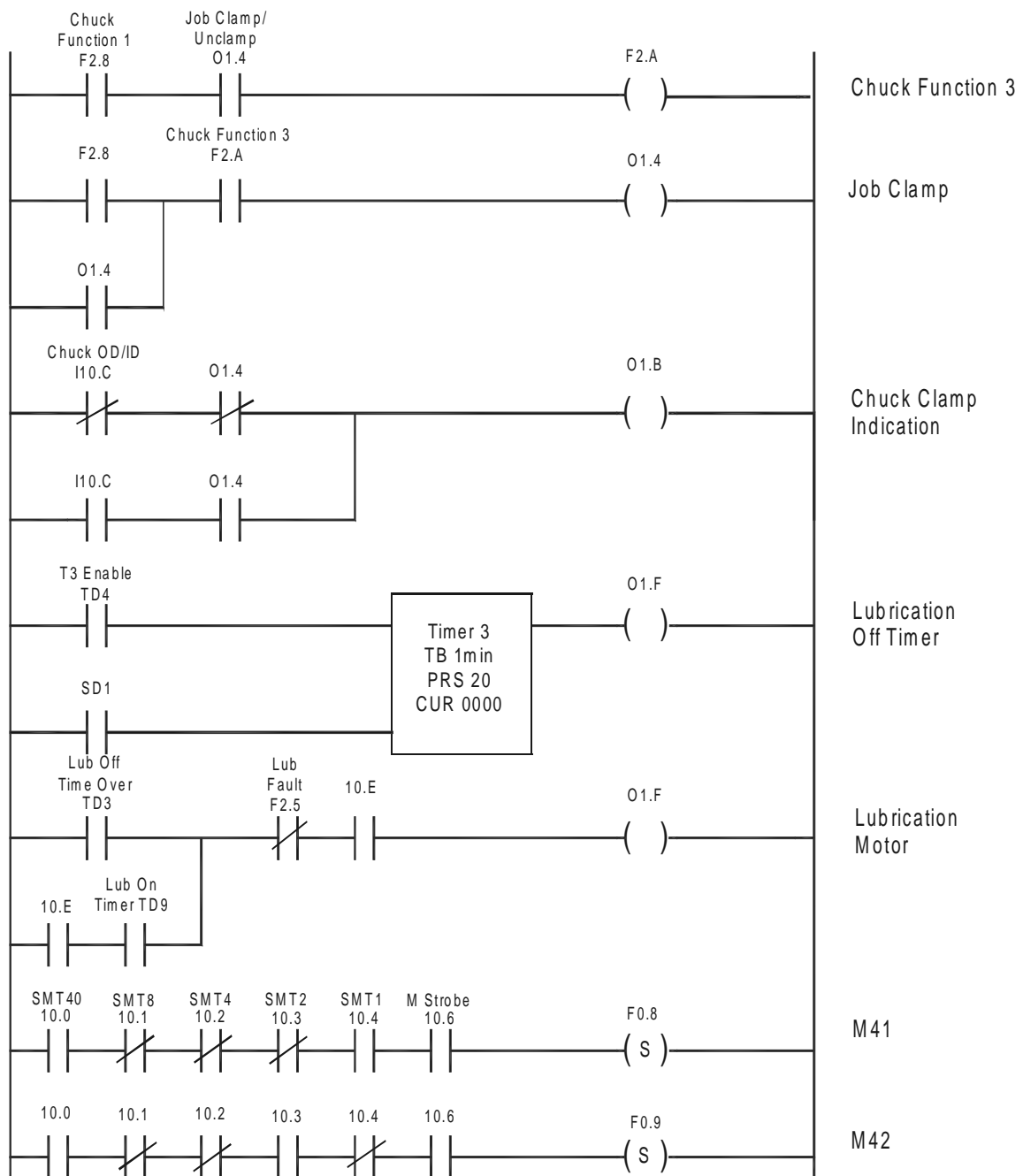
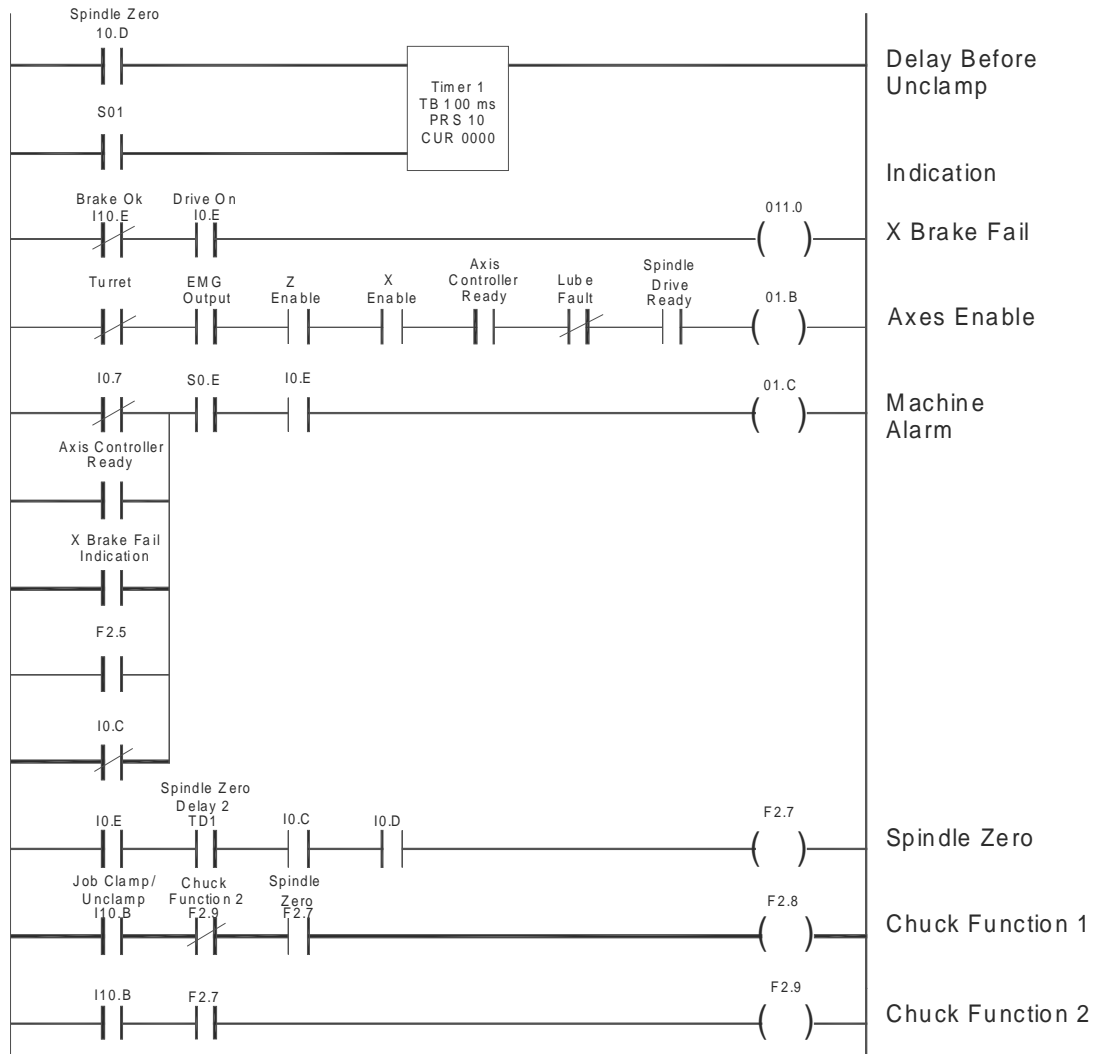


Fig. 11.8 (a) One Section of PLC Ladder Diagram



**Fig. 11.8 (b) Another Section of PLC Ladder Diagram**

### 11.8 FACTORY LEVEL CONTROL

Factory automation systems monitor the production flow in a manufacturing or industrial environment. There are various processes taking place in a manufacturing plant. The suppliers of raw materials, components and subsystems are often distributed throughout the world. Similarly at the other end, the customers are also globally distributed. There may be several plants for a manufacturing company and these plants may also be located at different countries. In a factory, materials are received, processed, packaged and shipped. Several materials handling activities will be involved during the process of manufacture. The machinery may include motion and drive control systems, which need

continuous control and monitoring. The manufacturing or process operations have to be monitored using appropriate sensors located in the machinery or shop floor. In addition, there will be several utilities connected with the plant, which require monitoring and control. It is desirable that these are controlled from a single integrated system. It is also necessary that such systems should be scalable to accommodate future expansion.

Many companies like Siemens, Rockwell, and Honeywell etc. provide such integrated automation systems. The Rockwell Automation system is mentioned here as the example of integrated architecture. This uses a combination of enabling technologies like Logix control platform, NetLinx open network architecture, View Visualization Platform and FactoryTalk data and information services. Brief descriptions of each of the above are given below, courtesy Rockwell Automation.

The Logix control platform enables the user to choose the most effective controller for a given application. These are programmed through a single software package. Programming can be done using any of the following:

- Ladder Diagram
- Function Block
- Sequential Function Chart
- Structured Text Language

The use of the Logix controller results in significant reduction in design, hardware and programming costs.

Netlinx open networks provide a network infrastructure information flow. These share a common protocol which enables seamless flow of information from the device on the plant floor to the enterprise system without additional programming. Reduced programming, increase in flexibility, reduction in installation cost and increased productivity are the benefits of this approach.

View Visualization platform is a unified suite of operator interface and supervisory level monitoring solutions, that share the same development software. The advantages of this system are faster development and implementation, flexibility and lower cost of ownership.

FactoryTalk is a suite of services embedded in integrated architecture components that simplifies data production, movement and use. FactoryTalk services give the user a tag only once and reuse it throughout the entire control system.

The advantages of such systems are:

- Improvement in response time and decision making
- Reduced maintenance cost and downtime
- Scalability to ensure future growth
- Increased operator response time
- Reduced implementation time
- Reduced costs
- Availability of information across the enterprise

**QUESTIONS**

1. Study the automation systems used in a manufacturing company.
2. Discuss the importance of low cost automation in improving productivity in small and medium industries.
3. Design a simple low cost automation system for automating turning and cutting off operations in a centre lathe.
4. Compare hydraulic and pneumatic automation systems.
5. Discuss the need for flexibility in automated manufacturing systems.
6. What are the essential elements of a PLC system?
7. Discuss with an example, the principle of operation of a programmable logic controller.
8. What are the roles of a PLC in a CNC machine?
9. Discuss the details of any one of the integrated plant automation software and hardware products.

# CHAPTER

---

# CNC MACHINE TOOLS

# 12

*Production equipment with computer numerical control is a major component of CIM. Computer numerically controlled (C N C) Machine Tools paved the way for introducing flexible automation on the shop floor. The technology of computer numerical control is today applied to a large spectrum of material processing equipment. The developments in CNC have been one of the major factors that have contributed to the evolution of CAD/CAM and subsequently CIM. For manufacturing a component, the CAD/CAM process generates a program, which can run on the CNC machine. The fundamentals of numerical control, the types of CNC machines and the programming techniques are presented in this chapter. The features of CAM software and CNC systems are discussed in detail. The integration of CNC machines in the CIM environment is also dealt with in this chapter.*

## 12.1 INTRODUCTION

After the Second World War, there was a big spurt in the design and development of aerospace products like satellites, launch vehicles, civil and military aircraft etc. The hydraulic copying and electrical program controlled machines used at that time could not meet the manufacturing challenges posed by the complex aerospace designs. The manufacturing engineers were therefore looking for a better way of automating the machining operations. Numerical control (NC) was developed in early 50's to meet the critical requirements of aerospace Industry. Many components used in aircraft and space vehicles are machined from solid raw materials, often involving removal of considerable stock and requiring several hundred positioning movements of the machine tool slides. Manual operation under these circumstances is not only tedious but also less efficient and unproductive. Often the part after several hours of machining is liable to be rejected due to machining errors.

Digital technology developed for communication purposes became very handy for designers of control of machine tools. Since the information required to actuate and control slides was coded numerically, this technology came to be known as numerical control.

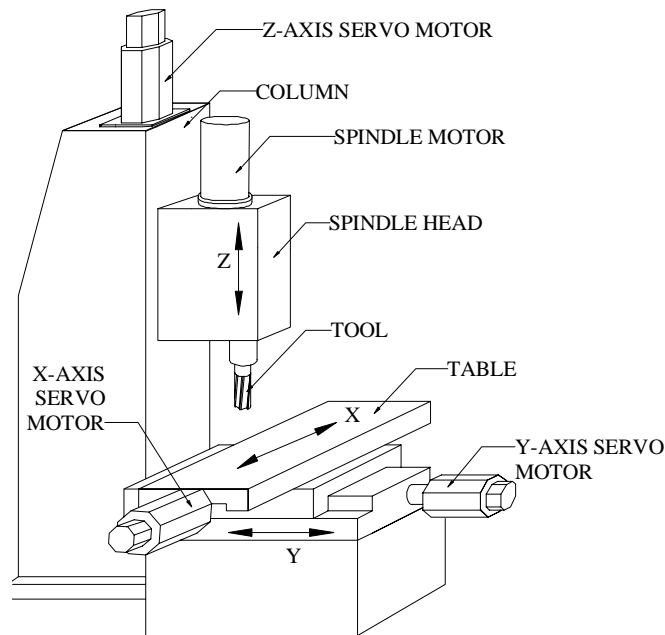
Early numerically controlled machines were fully hardwired machines as the entire control logic was implemented in hardware. This posed several difficulties in the operation of NC machines apart from serious limitations on reliability of operation. The designers of NC machines achieved a major breakthrough during mid-sixties when they could integrate a NC machine tool with a mini-computer. The technology was then renamed as computer numerical control. The integration of computers with NC machine tools resulted in the following advantages:

- Increase in the memory for part program processing
- Increase in capacity for storing large part programs
- Easy editing of part programs on the control console
- Realization of control logic through software
- Significant improvement in the reliability of operation of the machines
- Integration of N.C. machines in the manufacturing system as a whole.

Further developments in large scale integration resulted in the development of microprocessors around which computers could be designed. This naturally led to the development of CNC systems based on microprocessors. Today all CNC machines are microprocessor based and both NC and CNC mean computer numerical control.

## **12.2 PRINCIPLE OF OPERATION OF A NUMERICAL CONTROLLED MACHINE**

The CNC machine differs from a conventional manual machine in several respects. The principle of operation of a numerical controlled machine can be explained with the help of Fig. 12.1. The figure shows a vertical milling machine. For carrying out an operation like end milling the spindle head is to be positioned in Z- axis and the table in X and Y coordinate axes. The feed movement is to be realized by the individual or simultaneous movement of X and Y axes. Thus the milling machine requires three slide movements, which are usually referred as axes feed drives. A special feature of a CNC machine is that a separate motor called a servomotor individually drives each axis. AC servomotors are the preferred choice for this purpose today. DC servomotors were widely used earlier. The slides are driven by the servomotors through re-circulating ball screw and nut assemblies. The use of re-circulating ball screw reduces friction, backlash and wear. The low friction reduces the torque required at the motor and the lost motion through torsional deflection of the screw. The use of ball screws also improves the dynamic response of the system. In some modern designs, particularly in the case of high-speed machines, linear motors are used in the place of servomotor ball screw combination.



**Fig. 12.1 Sketch of a Numerically Controlled Machine Tool**

In order to carry out the milling operation on the workpiece the coordinate information (X, and Y coordinates) of the starting point and the ending point has to be coded in the NC program. Similarly, the information regarding the direction of rotation and speed of the spindle, use of coolant, and the feed rate is also coded suitably. The CNC controller decodes the positioning information coded in the NC program and the slide is moved to the programmed position at the required feed rate. Each slide is fitted with a feedback transducer, which continuously monitors the slide position and compares with the programmed position as well as the feedrate. The feedback transducer is mounted either on the slide or on the servomotor and measures the displacement or position of the slide.

For example, let us assume that a hole is to be drilled at the location  $X = 100.0$  and  $Y = 150.0$ . The corresponding block of the program is read by the control system and the necessary inputs are sent to the X and Y-axis servomotors. These motors drive the respective slides to the commanded position. When the distance information from the feedback devices equals the programmed values, the slide movement stops. The input is then given to the Z-axis servomotor to perform the drilling operation. The system switches on the motor driving the spindle carrying the drill and commands the Z-axis servomotor to move at the programmed feedrate into the workpiece till the programmed depth is reached. The Z-axis feedback transducer ensures the correct depth and feedrate. The drill is then withdrawn to the desired height and the machine starts the positioning movements to the next location of the drill. This procedure thus ensures production of accurate workpieces.

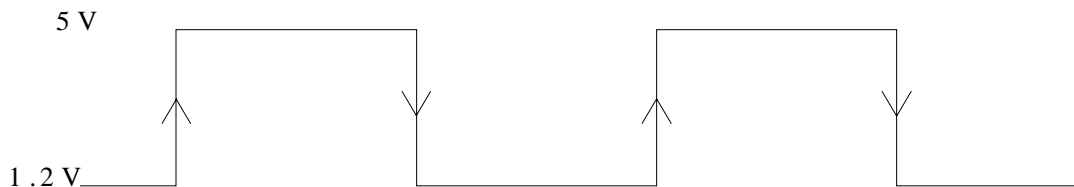


The feedback transducer used may be analog (synchro resolver) or digital (encoders). Another classification of feedback transducer is based on their nature of measurement-absolute or incremental. They are also classified as linear or rotary depending upon their construction. Linear feedback devices include optical scales, inductosyn etc. Rotary feedback devices are mounted either on the ball screw or on the motor shaft and measure the slide position indirectly. Rotary encoders, optical scales, and synchro resolvers are the commonly used rotary feed back devices.

The measured and the targeted positions are compared and the servo system ensures that the correct positioning is achieved to make this error (difference between targeted and measured positions) zero. The resolution of axis feed drive is usually one micrometre. Since positioning is done electronically, it is possible to achieve accuracy and repeatability of the order of 5-10 micrometres even under heavy-duty cutting conditions. Two servo loops are incorporated in feed drive - one for the position and the other for the feed. In addition to this, the selection of spindle speed is also under servo control. The principle of operation of the servo system used in a CNC Machine tool is described below.

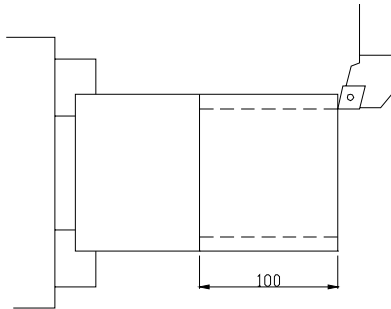
### 12.2.1 PRINCIPLES OF OPERATION OF A CNC SERVO SYSTEM

A CNC servo system works on the digital principle. In a digital system, the control signal is in the form of electrical pulses. Figure 12.2 shows a typical pulse train. A pulse train will have a low voltage level (say 1.2 V) and higher voltage level (say 5 V). Low voltage level is referred to as '0' state and high voltage level '1' state. Higher voltage may be negative also. Different higher voltage levels may also be used for control purposes.



**Fig. 12.2 A Typical Pulse Train**

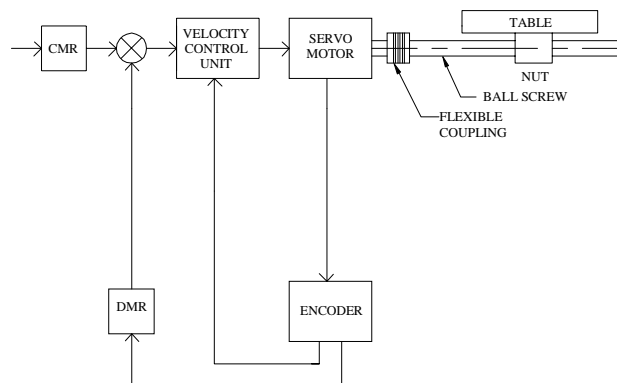
Consider the turning operation shown in Fig. 12.3. The tool has to move through a distance of 100 mm to carry out the turning operation. This distance is converted into pulses- one pulse for each micrometre (1/1000 of a mm). For 100 mm distance, a command signal of 10 000 pulses is generated by the control system.



**Fig. 12.3 Turning Operation**

The resolution of the system can be improved by a factor called Command Multiply Ratio (CMR). If the feed is 0.2 mm/rev, and the spindle rpm 1000, the slide velocity will be  $1000 \times 0.2 = 200$  mm/min. If the pitch of the ball screw is 10 mm, the rotational speed of the Z servomotor should be  $200/10 = 20$  rpm. The command signal ( $\pm V$ ) from the velocity control unit will have a magnitude proportional to the speed required. Plus or minus signal denotes the rotation in clockwise or anticlockwise direction which is necessary for positive and negative movements of the table in any axis.

The feed back unit is a significant element of a CNC control system. The feedback involves measurement of position as well as feed velocity (feed rate). In a majority of cases, the encoder, which is used as the feed back device, generates 2000, 2500 or 3000 pulse per revolution. The detect multiple ratio (DMR) matches the resolution of the feedback transducer (thereby the pulses produced by the transducer) and the pulses necessary to move the slide to the required position. The feedback encoder is usually mounted on the rear side of the axis servomotor itself to simplify the electrical connections. From Fig. 12.4 it can be seen that there are two servo loops in the axis drive - the outer loop for position and the inner loop for feed rate. The feedback signal for the feed rate is the pulse rate or pulse frequency. The frequency/voltage converter converts the pulse frequency into an analog voltage and this is compared with the input signal to the motor.



**CMR:** Command multiply ratio

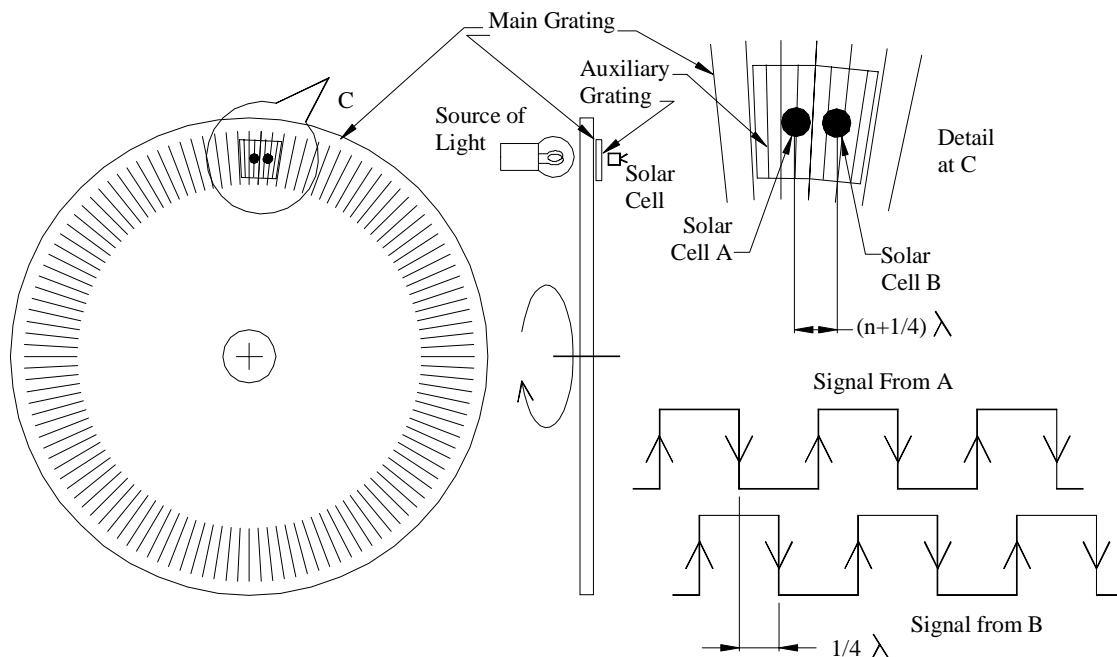
**DMR:** Detect multiply ratio

**Fig. 12.4 Block Diagram of Servo Control**

The encoder generates pulses corresponding to the rotation of the motor (which is proportional to the table movement). The detect multiply ratio (DMR) is used to equalize the command pulse and the pulse generated by the encoder. The pulses corresponding to the table position are compared to (or subtracted from) the command pulse. When the feed back pulses become equal to the command pulse, the table reaches the stipulated position in the program.

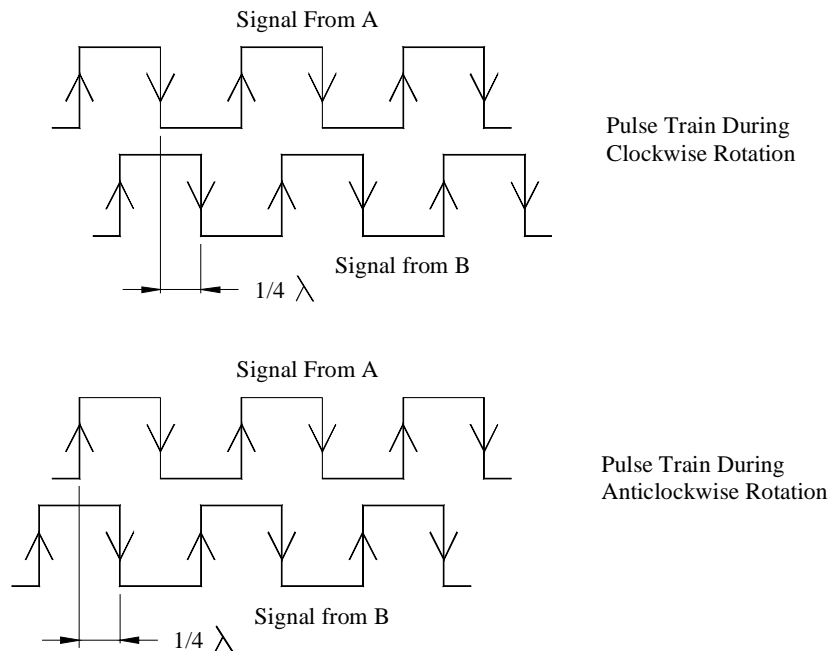
The encoder generates the feedback pulses. Pulses are generated by allowing light to pass through a two glass discs, one mounted on the motor shaft and rotating along with it and a small auxiliary disc mounted in the encoder housing. A source of light is located on one side of the disc. Interference fringes are created when the motor shaft rotates. In the simplest case, two light receiving stations (usually solar cells) are located on the other side (A and B) on which the light falls. The interference causes variation in the intensity of light falling on the solar cells. This results in a cyclic change of resistance, which could be utilized to create a pulse train using suitable electronic circuitry. The two solar cells are so placed that the distance between them is equal to  $(n+1/4)\lambda$  where  $\lambda$  is the pitch distance of the gratings. This is shown in Fig. 12.5.

The two solar cells then generate two pulse trains with a phase difference of  $1/4$  wavelength. Depending on the direction of rotation, the pulses from B will precede



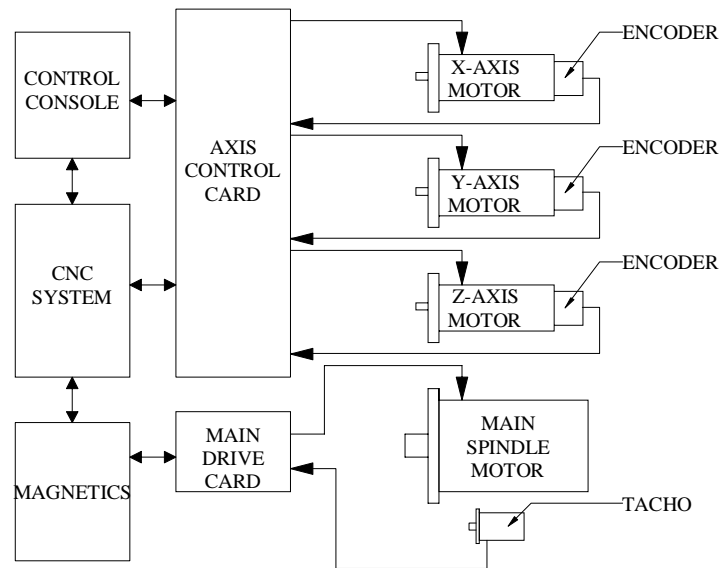
**Fig. 12.5 Feedback Using Encoder**

or follow the signal from A. This property is used to sense the direction of movement of the slide. This is illustrated in Fig. 12.6. When the disc rotates in the clockwise direction the signal from A precedes the signal from B. When the rotation is in the anticlockwise direction, the signal from B precedes that of the signal from the solar cell A.



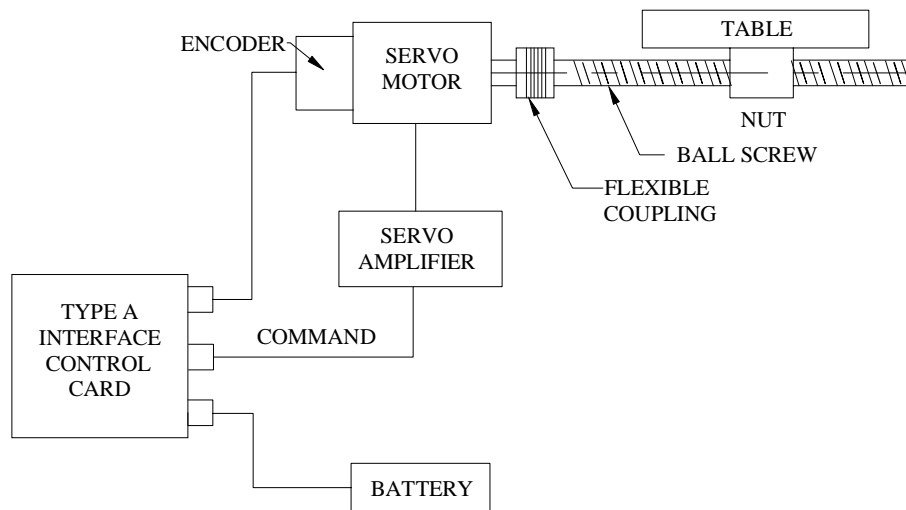
**Fig. 12.6 Detection of Direction**

An overview of a 3-axis CNC system is shown in Fig. 12.7. It can be seen that there are three major subsections in the CNC system. The first section consists of AC Power unit, programmable machine control PCB, the magnetics cabinet, operator's panel and manual pulse generator (MPG). The axis control and drive control PCBs have interfaces with this section and controls the positioning as well as velocity control of the 3 axes. The spindle speed control is also shown. The actuator section consists of servomotors and feed back units (Encoders or linear scales). The spindle is fitted with a spindle encoder. This will be useful in during thread cutting to enable the tool to enter in the groove created in the previous pass in the same angular position. This will also be useful for cutting multi-start threads as well as to monitor spindle speed. There will also be an interface for manual pulse generator (MPG), which is used to move the slides in the manual mode.

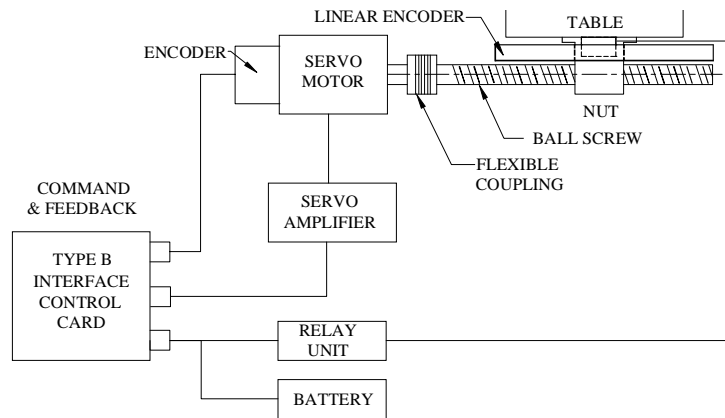


**Fig. 12.7 An Overview of a 3-axis CNC System**

In some systems, only one encoder is used and it serves as both position and velocity feedback unit. The encoder is mounted at the back of the servomotor (semi-closed loop system). This is illustrated in Fig. 12.8. In other systems (closed loop system illustrated in Fig. 12.9), separate feedback units for position and velocity are used. In this case, the position feedback is derived from the table position and velocity feedback is obtained from the servomotor speed. If the position feedback is obtained this way, errors due to backlash, pitch error, ball screw compliance etc. can be eliminated.



**Fig. 12.8 Semi Closed Loop System**



**Fig. 12.9 Closed Loop System**

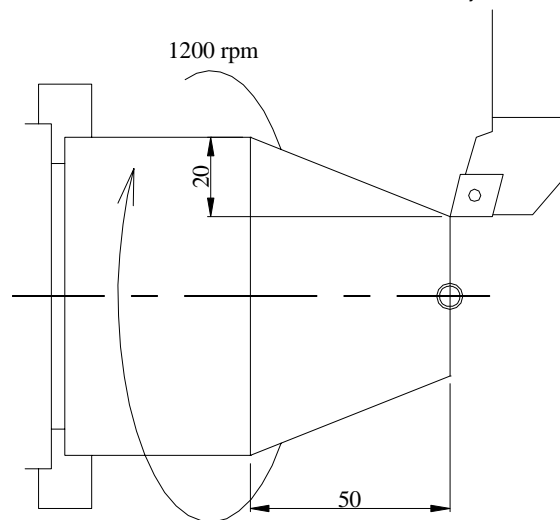
CNC machine tools employ AC motors (DC motors in older versions of CNC machines), which offer infinite variation of spindle speeds over a wide range of speeds. Digital technology is used in the modern AC drives. AC motors are capable of delivering high power at low base speeds. The main advantages of AC motors are their ruggedness and low cost.

**12.2.2 CODING OF INFORMATION IN NC MACHINES**

NC as described earlier is control by numbers. NC is control by information contained in a part program, which is a set of coded instructions given as numbers for the automatic control of a machine in a pre-determined sequence.

Figure 12.10 shows the machining a taper on a cylindrical component. To carry out this operation on a CNC lathe, we write a program block as follows:

```
N005 G01 U20 W-50 S1200 F0.2 M08;
```



**Fig. 12.10 Machining a Taper**

The program block codes the information necessary to operate the lathe, and is given below:

N005	Block number
G01	Linear interpolation
U20	X increment in slide movement
W-50	Z increment in slide movement
S1200	Spindle speed, 1200, rpm
F0.2	Feed, 0.2 mm/rev
M08	Coolant on
;	End of block

Each of the above consists of an alphabet or a word address (**N, G, U, W, S** etc.) and a numeric value (005, 01, 20, -50, 1200), which represents a function or a slide displacement position or machining data. These alphanumeric data is digitally coded either in the ISO (International Standardization Organization) system or EIA (Electronics Industries Association, USA) system. The symbol ';' denotes end of the block.

### 12.2.3 CODING OF INFORMATION

Early NC systems coded only numeric data and they did not use any alphabetic characters. Since all the information necessary to carry out the machining operation is passed on to the control system through these coded numerical data, the control came to be known as numerical control (NC).

The numeric data is usually represented in decimal format. For the purpose of the convenience in processing in a digital computer, the data is to be converted (coded) into binary form. A decimal number is represented in binary form as a power of 2.

To represent large number a binary coded decimal (BCD) system is employed. Consider the 4-track coding system shown below. Rightmost track is  $2^0$  (least significant) and leftmost track is  $2^3$  (most significant). For example the number 358 can be represented as:

$2^3$	$2^2$	$2^1$	$2^0$		
0	0	1	1	3	(2+1)
0	1	0	1	5	(4+1)
1	0	0	0	8	(8)

There are two standards for coding, one proposed by ISO (International Standardization Organization) and the other by EIA (Electronics Industries Association of USA). There are several other codes popular with the designers of NC systems.

### 12.3 HISTORICAL DEVELOPMENT

As mentioned in the beginning of this chapter, the need for a new technology to control machine movement was felt during late 40's to meet the challenges in the production of aerospace components. The manufacture of many of these components involves several thousands of machine movements.

A major contribution to this development was made by John Parsons who developed a technique to machine accurate templates to manufacture helicopter blades. This involved calculating 200 points on a curve and drilling them on a precision jig mill. He subsequently developed in 1948 a 3-D method of machining using ball end mill on a SIP jig bore and a De Vlieg jig mill. The successive settings of the tool were determined using the IBM punched card reader. Parsons was later entrusted with the development of a (NC) milling machine working on the same principle. The U S Air Force was the funding agency for the NC development. Parsons found that card reader is too slow and approached Massachusetts Institute of Technology (MIT) to develop a tape reader and power drive for the proposed machine. The collaboration between Parsons and M I T ran into difficulties later. U S Air force, then, awarded a contract to M I T. The Servomechanisms Laboratory of M I T developed the first NC Machine in 1952. Giddings and Lewis, General Electric and Bendix are the companies who took interest in developing NC technology, in its early years.

The development of the machine hardware and the programming technique called Automatic Positioning of Tools (APT) was undertaken almost simultaneously at MIT. It must also be noted here that another project undertaken at that time at M I T (Whirl Wind Project) led to development of Interactive Computer Graphics. This ultimately led to the development of CAD technology through stages like 2-D drafting, 3-D modeling, surface modeling, solid modeling etc. The project to develop drives resulted in the development of DC variable speed drives. The first CNC system developed at MIT used relays. Subsequent developments in electronics and VLSI design led to the development of present generation CNC machines and computer aided manufacturing technology. The efforts to integrate CAD and CAM and later all other activities connected with manufacture resulted in the development of Computer Integrated Manufacturing. (CIM). It can be said that the path breaking development of John Parsons is the beginning of the CIM technology.

Presently, all the NC machines produced are computer numerical control machines, as the NC system (or CNC system) is designed and built around one or more microprocessors. CNC Machine tools now form a major part of output of machine tools in advanced countries. Table 12.1 gives the status of CNC Machine tool production in India in 2002.



**Table 12.1 Production of CNC Machines in India During 2002**

<i>Type of Machine</i>	<i>Number</i>
Lathes	732
EDM	339
Vertical Machining Centre	251
Horizontal Machining Centre	37
Other Types of machining Centres	6
Boring	12
Milling	41
Grinding	49
Gear Cutting	25
SPM	27
Bending, Folding etc.	82
Punch, Shear etc.	20
Others	34

(Courtesy: Indian Machine Tool Manufacturers Association)

### 12.3.1 GENERATIONS OF CNC MACHINES

Development of CNC machines closely followed the developments in computer technology. Therefore the generations of CNC technology bear a close resemblance to generations of digital computers.

**First Generation:** The control system of the first generation numerically controls machines was built with vacuum tubes and associated devices. The system was bulky, consumed lot of power and reliability was poor.

**Second Generation:** Second Generation machines were built with transistors. The size of the control elements was reduced. However, all the functions had to be realized through electronic circuits. The number of printed circuits boards was large. Since there were thousands of components and connections involved, the reliability was again poor.

**Third Generation:** Third generation NC machines were built with integrated circuits. The IC's with medium scale integration improved the reliability of the system. Drive technology also made considerable progress. Thyristor controlled DC drive become popular during this period. Reliable and compact DC controllers were developed both for main drives and for the control of servomotors for axes feed drive.

The various logic functions in the early NC systems (during 50's and 60's) were realized through fixed circuitry and hence were called hard-wired systems. The integration of minicomputers with NC machines that led to the development of CNC machine tools was one of the two major significant developments during mid 60's. Initially minicomputers were interfaced with NC machine tools. This development helped to introduce the much-needed flexibility. From the totally hardwired design, the design of the NC machine tools became soft-wired. Instead of reading and executing programs block by block it was now

possible to store the program in the computer memory and execute the program. Several limitations of the NC systems could also be overcome by CNC systems. Program editing became much easier and several NC functions could be implemented in software. The other development was the evolution of the concept of Direct Numerical Control (DNC) technique by which several NC machine tools could be controlled from a single computer. This technology enabled the NC user to by-pass the tape reader and control a number of NC machine tools from a single computer. DNC system manufacturers also introduced the concept of NC data transfer from a computer or remote station using telecommunication wires. A detailed description of DNC systems is provided later in this chapter.

**Fourth Generation:** Towards the end of 70's the computer design underwent changes and microprocessor came to be used as the CPU of computers. This change also influenced the design of NC machines. The designers started developing NC systems around microprocessors. This simplified the logic and control and design and instead of several PCB's in the case of NC machines, the entire control could be implemented with just one PCB for CNC machines. Initially 8 and 16 bit microprocessors were used. Later control systems with several processors (Multi-processing Systems) were introduced. The reliability of the system was considerably improved. The developments in CNC systems still continue. Today many CNC systems are based on 32 bit as well as 64 bit microprocessors. Several personal computer based CNC systems are also available in the market. Features available in modern CNC systems are discussed later in this chapter.

## 12.4 TYPES OF CNC MACHINES

Computer numerical control is applied to a variety of machines. Most of these find ready application in aircraft, automobile and general engineering industry. Some of them are listed below:

- i. Machining Centre
  - Horizontal
  - Vertical
  - Universal
- ii. CNC Lathes
- iii. CNC Turning Centres
- iv. Turn-mill Centres
- v. CNC Milling/Drilling Machines, Plane Milling Machines
- vi. Gear Hobbing Machines
- vii. Gear Shaping Machines
- viii. Wire Cut EDM/EDM
- ix. Tube Bending
- x. Electron Beam Welding

- xi. Laser/Arc/Plasma Cutting
- xii. Co-ordinate Measuring Machines
- xiii. Grinding Machines
  - Surface Grinder
  - Cylindrical Grinder
  - Centreless Grinder
- xiv. Tool and Cutter Grinder
- xv. CNC Boring and Jig Boring Machines
- xvi. PCB Drilling Machines
- xvii. Press Brakes
- xviii. CNC Guillotines
- xix. CNC Transfer Lines, SPM's
- xx. Electrochemical Milling Machines
- xxi. Abrasive Water Jet Cutting Machines
- xxii. Flow Forming Machines
- xxiii. Roll Forming Machines
- xxiv. Turret Punch Press

Brief descriptions of some of these machines are given below:

#### **12.4.1 MACHINING CENTRES**

Manufacture of prismatic components like gear boxes, bulkheads, frames, brackets, casings, covers etc require milling, boring, drilling, tapping and many other related machining operations to be performed. Before the introduction of machining centres, these machining operations had to be carried out on different machines resulting in considerable lead time for production. Machining centres are very important types of CNC machine tools and are multifunction machines equipped with automatic tool changers and are capable of carrying out milling, drilling, reaming, tapping, boring, counter boring and allied operations without operator intervention for change of tools. Tool changing is carried out using an automatic tool changer and is accomplished in 0.5 to 6 seconds depending upon the machine.

An indexable tool magazine, which can store several tools, characterizes a machining centre. The tool magazine may carry 16 to 100 tools depending upon its capacity. An automatic tool changer (ATC) is provided to pick up the programmed tool from the tool magazine and mount it on the spindle. The removed tool is put back into the magazine and the ATC picks up the next tool. The ATC is thus ready with the tool for the next operation and awaits the current operation to be over to replace the tool.

Machining centres are often provided with two or more work tables called pallets. In a 2-pallet machine while the job on one pallet is being machined, the operator can set up the next job on the free pallet. The automatic pallet changer (APC) then moves away the pallet with the finished job from the working zone and moves the other pallet with the new workpiece to the working zone. The machining operation on the new workpiece begins with a lapse of only a few minutes.

The operator can now unload the finished job from the first pallet and set up a new workpiece on it without interruption of the machining operations.

There are machining centres with six, eight or more pallets. Workpieces can be set up in all pallets and the machine can be programmed to accept a new pallet when work on the previous pallet is completed. The workpieces may be different and may require different part programs. The supervisory computer will do the selection of the right program. Thus the two major sources of non-productive time (tool change and setting up the workpiece) are reduced to very low values. This enables machining centres to have high productivity as well as considerable reduction in the lead-time of production of complex components. This also reduces work in process (WIP) appreciably.

Machining centres are classified according to the spindle configuration as:

- a. Horizontal spindle machining centres
- b. Vertical spindle machining centres
- c. Universal machining centres

#### 12.4.1.1 Horizontal Spindle Machining Centres



*Fig. 12.11 Horizontal Machining Centre (Courtesy: AMS)*

Horizontal spindle machining centres are generally single spindle machines with automatic tool changers. Some exceptions are machines with turret type tool magazine, combination horizontal/vertical spindles etc. Horizontal spindle machining centres are generally bed type machines with the structural configuration as shown in Fig. 12.11.

In this type of machining X-axis table or column provides traverse and spindle head provides Y-axis traverse. The saddle or column, or headstock or spindle head provides the Z-axis traverse. The axes of machining centre are also shown in Fig. 12.11. These machines are invariably used with a rotary indexing table to facilitate multiphase machining at different angles in a single setup. The axis of rotary table is parallel to Y-axis and is called 'B' axis.

The rotation of the table can be used for machining contours on surfaces of workpieces located on the rotary table, if CNC control is available for B-axis. The provision of B-axis enables the machining of all the four sides of the component in one set up. Use of modular fixtures on horizontal machining centers permits machining of more or more components in one set up, thereby increasing productivity and reducing machining cost. Table 12.2 gives the specifications of a typical horizontal machining centre.

**Table 12.2 Specifications of a typical Horizontal Machining Centre**

<b>Traverses</b>		
Saddle - longitudinal	X-axis	800 mm
Spindle head-vertical	Y-axis	700 mm
Column-cross	Z axis	800 mm
<b>Feeds</b>		
Rapid traverse	all axes	12000 mm/min
Feed rate	all axes	1-4000 mm/min
<b>Spindle</b>		
Spindle taper	BT 50	
Speed	Infinitely variable	
Range	20-4000 rpm	
Power	15 kW (AC)	
<b>Automatic Tool Changer (A T C)</b>		
Tool capacity	32 (nos)	
Maximum tool diameter	100 mm	
Maximum tool length	400 mm	
Tool changing time	4 sec	
Tool selection	Random bi-directional	
<b>Accuracies: (Japanese Industrial Standard)</b>		
Positioning accuracy	+/- 0.005	
Repeatability	+/- 0.0025	
Index table (1)		
Position accuracy	+/- 3 sec	
Repeatability	+/- 2 sec	
<b>Automatic Pallet changer</b>		
No. of pallets	2 nos	
Pallet changing time	40 sec	

The present day trend is to build the machines with traveling column construction with all the movements behind the tool so that the work module is independent of the basic machine. This enables choice of work holders to suit the user's requirements and also enables the use of machining centre in NC transfer lines.

#### 12.4.1.2 Vertical Spindle Machining Centres

Figure 12.12 shows a typical vertical spindle machining centre.



**Fig. 12.12 Vertical Spindle Machining Centre (Courtesy: AMS)**

Vertical spindle machining centres are also bed type machines with:

1. Single spindle and automatic tool changers
2. Multi spindle with turret head (Turret machining centres)
  - X-axis traverse provided by table or column
  - Y-axis traverse provided by the saddle or the column or ram
  - Z-axis traverse provided by the headstock

Vertical spindle machines are not suitable for large widths as this increases the throat distance. For very large widths horizontal spindle configuration or bridge type configuration (double column planer type) is used. Table 12.3 gives specifications of a typical vertical machining centre.

**Table 12.3 Specifications of a Vertical Machining Centre**

Effective table area (mm)	:	550 x 1400
Loading capacity of table (kg)	:	1500
Travels (mm)		
X-axis	:	1000
Y-axis	:	550
Z-axis	:	550
Distance (mm) from spindle to table surface	:	200 - 750
Distance (mm) from spindle centre to column front face	:	590
Rapid traverse (m/min)	:	15
Feed rate (mm/min)	:	1 - 4000
Spindle diameter (mm)	:	100
Spindle nose taper	:	JIS -B6101 - No: 50
Spindle speed (rpm)	:	20 - 4000
Spindle drive motor (kW)	:	AC 7.5
30 min rating (kW)	:	10
Automatic tool changer:		
No. of tools	:	40
Max.tool weight (kg)	:	15
Max.tool dimensions (mm)	:	120 x L400
Tool selection	:	Random Memory (Bi-directional)
Machine weight (kg)	:	7800

#### 12.4.1.3 Universal Machining Centres

These are similar to horizontal machining centres but with the spindle axis capable of tilting from horizontal to the vertical position continuously under computer control. This constitutes the fifth axis of the machine. In some cases tilting of the table instead of the spindle provides the movement. Such machines facilitate access to the top surface of workpiece mounted on a horizontal machining centre so that all the five sides of a component can be machined in a single set up. The fifth axis facility is essential for machining of some components, which require the cutter axis to be perpendicular to the surface being machined. Machining centres can be easily integrated into a flexible work cell. Provision of bi-directional random memory tool magazines, automatic tool offset measurement, magazine changers, advanced tool management techniques, tool breakage detection techniques, rail guided work transport, palletizing stations, in-process gauging, devices for automatic workpiece loading and unloading etc., are useful options to improve productivity and to realize flexibility in operation and to achieve unmanned operation of machining centres.

#### 12.4.1.4 Recent Advances in Machining Centres

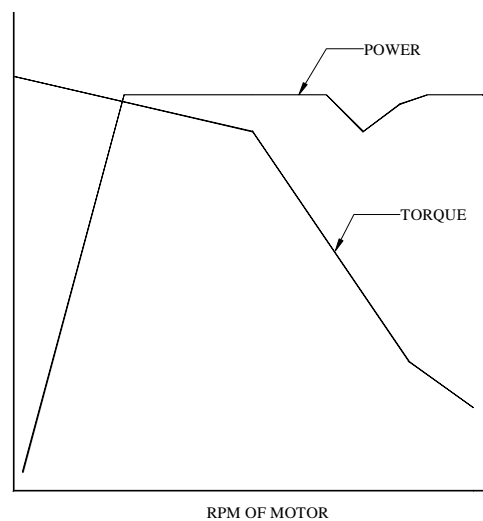
Some of the recent technological developments in machining centres are described below:

### i. Vector Spindle Drive

Vector drive optimizes the slip angle between the rotor and the stator of the spindle motor to double the low speed torque and acceleration resulting in a fast and most powerful spindle. Fig. 12.13 shows typical torque speed characteristics of vector control drive.

### ii. Brushless A.C. Servomotors

A typical A.C. servomotor used in a machining center will have 32000 divisions per revolution for high accuracy. These motors provide higher acceleration/ deceleration rates, higher power and reliability.



**Fig. 12.13 Vector Drive**

### iii. Hydraulic Counterbalance

Conventional lead and chain counterweight systems used in machines are found to cause a bouncing effect during peck drilling, shock during quick reversals, vibration etc. These affect the quality of the surface finish of the component. Hydraulic counterbalance eliminates the bounce, reduces the z-axis inertia to half and provide a smooth and fast Z-axis response.

### iv. Spindle Cooling

With the introduction of high speed spindles, considerable amount of heat is generated at the spindle and this heat unless removed will cause thermal distortion to the spindle head. Spindle cooling has therefore become very critical. Several innovative techniques are used to remove the heat generated in the spindle. A common method adopted is to circulate refrigerated oil to the bearings. In another design, cool air is drawn from the rear of the machine and is allowed to exit at the top of the spindle, thereby effecting cooling through natural heat convection.



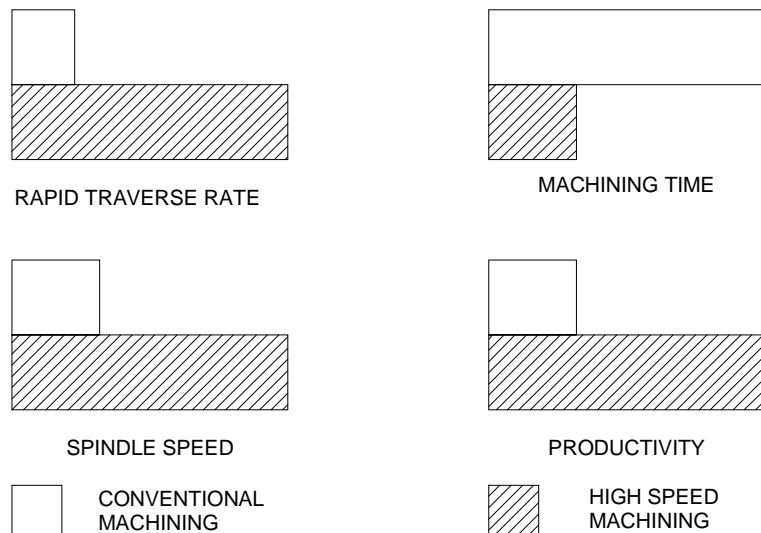
### v. Electronic Spindle Orientation

Spindle orientation is important for smoother and faster tool change. Electronic orientation used in the machining centres provides reliable and trouble free operation and enables reduction in tool changing time.

### vi. High Speed Machining Centres

High-speed machining centres have spindle speeds ranging 12 000- 50 000 rpm. These machines are usually designed with hybrid (ceramic) bearings, oil mist lubrication and water or oil cooling of spindles for maintaining constant temperature. Dynamic feed drives with low friction ball screws and linear roller guide ways are some of the special features of these machines. These machines are fitted with control systems, which feature processors and intelligent control strategies that provide extremely rapid response and precise traverse. Some of the features include advanced look-ahead, various methods of spline interpolation and full compensation for lag errors.

Two significant aspects of high speed machining centres are high rapid traverse rates and high spindle speeds. Figure 12.14 compares the rapid traverse rates and spindle speeds of conventional machining centres and high speed machining centres. The total machining time can be significantly reduced with high speed machining.



**Fig. 12.14 Comparison of High Speed and Conventional Machining Centres**

### 12.4.2 TURNING CENTRES / CNC LATHES

CNC lathes are widely used in making components with axisymmetric geometry. These are generally machined with 2-axis control. (Z-axis parallel to the spindle and X-axis perpendicular to spindle axis). A CNC lathe is shown in Fig. 12.15. Some CNC lathes have an additional Y-axis. CNC lathes are usually designed with a slant bed for easy removal of chips, at the same time maintaining the rigidity of a closed box structure. A chip conveyor (either magnetic or mechanical) is usually provided for easy chip disposal. The control console is located on the front on top side. The spindle is driven usually by an infinitely variable speed AC drive through a set of V-belts or poly belts. The high power series motors employed provide almost constant power for a large portion of the speed range. High-speed machines usually have integral rotor spindles. AC servomotors drive the X and Z slides usually. Sliding doors (sometimes automatic) with bulletproof glass windows are provided for safety and visibility of the machining zone. Hydraulic chucks are provided for clamping the workpieces. CNC lathes, being high-speed machines require special highly accurate and well-balanced chucks. Tools are mounted in indexable turrets which can hold 8, 12 or 16 tools.



*Fig. 12.15 CNC Lathe (Courtesy: ACE)*

A tool is called in the part program by the number of the pocket in which it is held. For example T06 means the tool in the 6<sup>th</sup> pocket. Tool stations are indexed using a Geneva mechanism powered electrically or hydraulically. An encoder or a similar device is used to index the turret. A curvic coupling is used to ensure high accuracy in indexing—usually 2 to 3 seconds of an arc. Both axial tools (boring tools, Internal grooving tools, internal threading tools, drills, face grooving tools, taps, dies etc) and radial tools (external turning, facing, threading, grooving, cut off etc) are mounted on the turret. It is a good practice not to mount axial tools in adjacent pockets. Tools, which are used more often, are provided in more than one pocket so that if the tool life of one tool is over the, other tool can take over the machining work without interruption to facilitate tool change or indexing of inserts. Short tool holders are recommended for better rigidity. A variety of adaptors are provided to mount different tools. Tool length offset must be measured and

input in the memory of the machine. Some machines will have an automatic tool length offset measuring device, usually mounted on the headstock.

CNC lathes and turning centres are used for chuck work and shaft work. These are classified as:

- (i) Horizontal machines and
- (ii) Vertical Machines

The horizontal machines are further classified as:

- (i) Chucking machines
- (ii) Universal machines

In chucking machines short workpieces held only in the chuck are machined. Examples of such components are gear blanks, flanges, pump impellers, bearing races etc. Universal machines have a tailstock, which supports long workpieces like shafts at their ends.

#### **i. Chucking Machines**

Chucking machines usually have shorter beds and a single saddle with hexagonal, octagonal, disc or drum type turret, which accommodates both ID and OD tools and two independent saddles with separate turrets. Many of the present day chuckers offer optional swing-in-tail-stock to facilitate shaft work. During normal working as a chucker, the tailstock is swung away from the work area. Chucking machines are fitted with additional sub-spindle to carry out both first and second operation in the same set up. These spindles will have synchronized drives to enable transfer of work from one spindle to another. In some machines the sub-spindle is fixed and work transfer is achieved with the aid of two turrets. Chucking machines are often fitted with bar feeding mechanisms. Twin spindle chuckers ensure high productivity. These are used for workpieces, which are to be finished in two end operations. The first operation is performed on the first spindle and the second operation on the second spindle. These will have an automatic work transfer system, which transfers the workpiece from one spindle to another. The advantage of these machines is that they ensure a continuous supply of parts for assembly operations. A typical example of a workpiece suited for such machines is the impeller of a centrifugal pump.

#### **ii. Universal lathes**

Universal lathes are suitable for both chucking and for bar work. They are often fitted with steady rest and follower rest to accurately machine slender components. 4-axis machines have two turrets; each mounted on an independent slide and facilitates simultaneous machining with two tools.

Some lathes have rotating tools in the turrets to facilitate off-axis machining such as drilling, milling, reaming, tapping, boring etc. These machines have in addition to the conventional X and Z-axes, CNC control of the spindle rotation i.e. C-axis. Such machines are known as turning centres. Turning centres eliminate the need for separate settings

for milling, drilling and allied operations. Turning centres enable the components to be finished in one set up thereby reducing lead time and improving the accuracy of machined parts. An automatic tool changer (ATC) can be used with CNC lathes also using the Block tooling system of Sandvik or Multiflex tooling system of Widia. CNC turning centres have rotating tools on the turret. With these tools operations like off-centre drilling, milling (keyway or slot milling), tapping etc. can be done on workpieces after turning. A servomotor is provided on the tool turret to drive the live tools.

This requires an additional axis called C-axis (spindle orientation control). Some machines will have special main drive, which will also serve the function of C-axis drive. Flexible turning centres are fitted with gantry loading and unloading devices, software and hardware for in-process and post-process metrology, automatic tool changers, automatic tool offset measuring devices, automatic offset correction, tool magazines, automatic chuck changers, chuck jaw changers etc., This type of machines use cartridge type tools which facilitate automatic tool change. Flexible turning centres easily get integrated in a CIM set up.

Productivity of CNC turning centres could be increased by attaching a gantry device for unloading and loading of components. Another approach is to use a robot for loading and unloading the component. Fig. 12.16 shows a typical robotic loading device.



*Fig. 12.16 Loading a Part Using a Robot (Courtesy- Kuka Robots)*

### iii. Tooling and Turret slide

The present trend is to have a single heavy disc type turret capable of accommodating both external and internal working tools. Some machines have two independent slides with one turret on each slide, one for external working tools and the other for internal tools. This arrangement will need 4-axis CNC. External and Internal machining can be carried out simultaneously. Alternatively

both slides can be fitted with turrets carrying external turning tools to facilitate simultaneously machining of steps of the shafts from either direction.

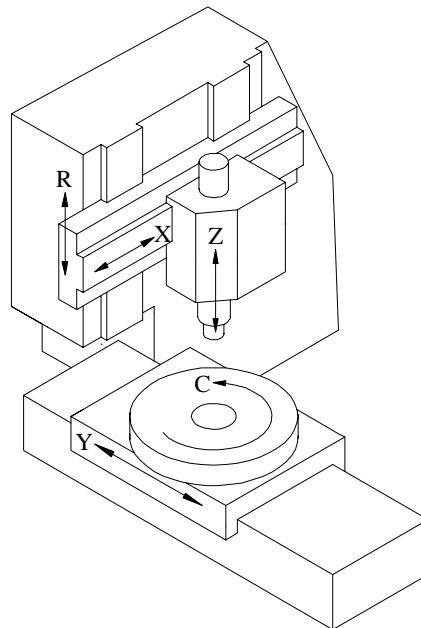
#### 12.4.2.1 Vertical CNC Lathes (Turn Mill Centres)

Vertical CNC lathes are widely used for machining heavy components. Figure 12.17 shows a typical vertical CNC lathe. Some of these machines can also be used for milling operations. Such machines are sometimes known as turn mill centres. This type of machines is very popular in aerospace industries where components of large diameters need to be turned, drilled and milled. The machine shown in Fig.12.17 has five axes—four longitudinal axes and one rotary axis.

#### 12.4.2.2 Multitasking Machines

Multitasking is a recent concept in CNC machines. Multitasking machines incorporate several processes in a single work center. For example, if a component requires milling, turning and grinding, a multitasking machine can be designed to carry out all these operations. This type of machine reduces the number of set ups and therefore reduces cycle times. Accuracy is improved as there are fewer set ups. Very often designers break down complex components into a number of parts to facilitate machining.

Multitasking machines eliminate this need thereby increasing the integrity of the part. Another advantage of multitasking is the possibility of cost reduction because of reduction in set ups, eliminating the need for several fixtures.



**Fig. 12.17 CNC Turn Mill Centre**

Table 12.4 gives typical specifications of a CNC Turning Centre. Table 12.5 gives typical specifications of CNC Lathe.

**Table 12.4 Specifications of a Typical CNC Turning Centre**

<b>Capacity</b>	
Swing over bed	580 mm
Max turning dia (chucking)	550 mm
Max turning length	529/1030/1530 mm
Max turning dia (shaft)	400 mm
Type of the bed	slant bed
<b>Spindle</b>	
Spindle nose/bore	A2-8 / dia 80
<b>Speeds</b>	
Spindle speed	10-3000
Type of the drive	A C drive
<b>Feed Drive</b>	
Feed range (Both axes)	1 – 30 000 mm/min
Rapid traverse - x axis	30 m /min
Rapid traverse - z axis	30 m / min
Resolution	0.001 mm
<b>Tailstock</b>	
Tailstock quill dia/stroke	90/80 mm
Type of the centre	MT4
<b>Turret</b>	
Turret indexing positions	12
Turning tool shank size	25 x 25 mm
Max shank dia for drilling and boring tools in turret	4 nos
Driven tools	4 nos
<b>Motors</b>	
Main motor AC	20 kW
Coolant motor	0.35 kW
Hydraulic pump motor	1.5 kW

**Table 12.5 Specifications of a CNC Lathe**

Maximum swing over cross slide, mm	170
Maximum swing over longitudinal slide, mm	310
Maximum turning length, mm	250
Main spindle motor, kW	8.5
Main spindle torque, Nm	75

Contd....

Spindle speeds, rpm	50-5000
Spindle nose	A2-8
Travel, mm	X 200, Z630
Feed, mm/min	1-30000 mm/min
Rapid traverse, mm/min	30 m/min
Type of tool turret	Bi-directional
No. of tools	8

### 12.4.3 CNC DRILLING AND MILLING MACHINES

CNC drilling and milling machines are used for production drilling of holes at different co-ordinate positions in workpieces with automatic cycles consisting of X-Y positioning, rapid approach of tool to workpiece, drilling with required feed rate to the required depth and rapid retraction of tool or various types of milling operations. The automatic cycle is controlled by the CNC system.

### 12.4.4 CNC GRINDING MACHINES

The grinding process is unique compared to other machining processes in that there is a very heavy "tool" (wheel) wear and that the process is very sensitive to process parameters like grinding pressure, speed and feed rates and flow of coolant etc. CNC has been successfully applied to all types of grinding machines. The workpiece size control is achieved by some method of automatic wheel wear compensation included in the grinding cycle or through an interactive in-process gauging system which is interfaced with the wheel in-feed drive. CNC can be used either to regulate the machine slides to generate a workpiece or to dress the wheel to the required shape to enable plunge grinding.

#### 12.4.4.1 Surface Grinding

In horizontal spindle reciprocating table surface grinding machines, CNC is applied only to the wheel head slide (Y-axis), as the most critical operation in these machines is the depth control. Conventional hydraulic drives are retained for feed and longitudinal traverse. In some machines the cross feed is replaced by an electric drive with a timer circuit or open loop control for feed. A closed loop control on the cross feed axis can be used directly to generate contours in the Y-Z plane while reciprocating the table in the longitudinal axis or to contour-dress the wheel for plunge grinding. In some cases the longitudinal traverse of the table is also provided with an electric drive. Table 12.6 gives specification of a typical surface grinding machine.

**Table 12.6 Specifications of Typical Surface Grinding Machine**

<b>Technical Specifications:</b>	
Hydraulic pump motor	1.5 kW
Maximum size of workpiece, (mm)	650x400
Maximum height of workpiece, (mm)	405
Table size (including the guards), (mm)	1885x470

*Contd....*

Average table speed, (m/min)	0 - 30
Automatic cross feed on the table reversal, (mm)	0 - 20
Grinding wheel diameter, (mm)	300 × 50
Spindle speed, (rpm)	1450 - 2900
Automatic vertical feed on table or saddle reversal, (mm)	0.005 - 0.025
Installed power, (kW)	11

#### 12.4.4.2 Cylindrical Grinding

In many cases CNC is provided only for wheel head slide to control diameters. In some cases CNC is provided for longitudinal traverse and wheel head traverse (2-axis) to control length of shoulders and diameter steps. Workpiece size is achieved by dressing the wheel with reference to fixed dressing point or by use of an interactive size control unit. Such machines can generate solids of revolution involving tapers, circular arcs and curved surfaces. Similar controls are available for internal grinders. Table 12.7 gives specifications of typical cylindrical grinding machines.

Figure 12.18 shows the schematic arrangement of a CNC grinding machine. X-axis is the in-feed direction of the grinding wheel. The longitudinal traverse of the grinding wheel is the Z-axis. The spindle rotation is the S1 axis. If the grinding wheel rpm is programmable, it provides the S2 axis. Swiveling of the wheel head is B-axis. Swiveling axis for dressing the wheel is the A-axis. C-axis is also provided on some machines. Figure shows only X, Z and S1 axes.

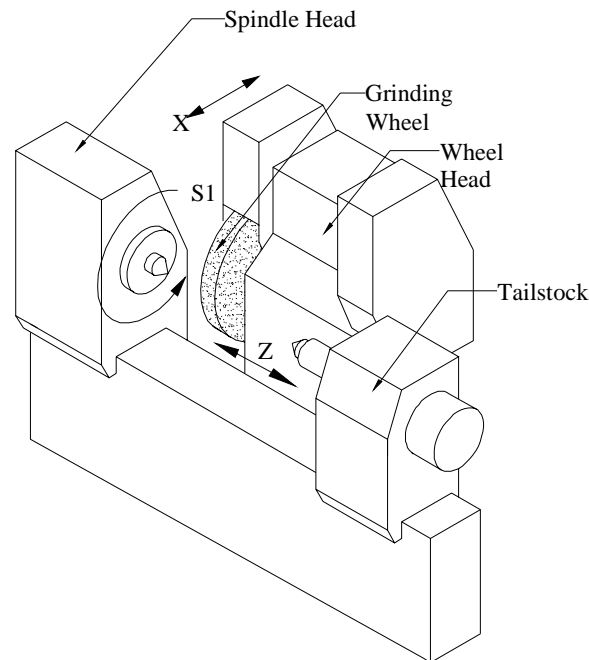
**Table 12.7 Specifications of a Typical Cylindrical Grinding Machine**

<b>Job accommodation</b>	
Height of centres	180 mm
Grinding dia min/max	20/300 mm
Distance between centres	1000 mm
<b>Work head</b>	
Barrel taper	MT5
Barrel actuation	
Forward/reverse	Hydraulic
<b>Table</b>	
Type of drive	AC
Feed rate	0.01 - 12 m/min
Rapid traverse	12 mm / min
<b>Wheel Head slide</b>	
In-feed stroke	300 mm
Type of drive	AC
Rapid traverse	6/6min
Feed rate	0.01 - 6000 mm/min

Contd....



Configuration	Right hand angular wheel / straight wheel
Approach angle	30 deg / 0 deg
Size of wheel max	750 mm
Wheel peripheral speed	45 m/min
Wheel head power	17.5 kW
Type of drive	AC



**Fig. 12.18 Cylindrical Grinding Machine**

#### 12.4.4.3 Tool and Cutter Grinders

CNC has been applied to complex tool and cutter grinders involving as many as eight axes. The control system working in an interactive mode with the part program residing in the memory leads the operator step by step reducing the programming effort to the absolute minimum.

#### 12.4.4.4 Profile Grinders

CNC has been used to advantage even on optical profile grinders. The control system has linear, circular and helical interpolation to generate complex contours, and has provision to dress the wheel and to compensate for wheel wear. Optics serves for tool setting, positioning the workpiece, checking wheel dressing and inspection of workpiece without removing it from the fixture.

## 12.4.5 ELECTRICAL DISCHARGE MACHINING

Electric discharge machine is an important machine in tool rooms. There are several types of electric discharge machines, which are fitted with computer numerical control.

### 12.4.5.1 Ram Type EDM

In this type of machine the electrode has to have the same size and shape of the counterpart of the workpiece being machined. Servo control is used to maintain the gap between the electrode and the workpiece.

### 12.4.5.2 Orbital EDM

In this type of machines, the electrode is in the form of a ball-ended cutter and spins about its own axis. The relative position of the electrode and workpiece is regulated by a 3-axis CNC system to generate any three dimensional surface.

### 12.4.5.3 Wire EDM

Wire cut EDM is an indispensable machine in tool rooms. This is used to make dies for blanking and piercing. The special feature of wire EDM is that the electrode is in the form of a thin wire of about 0.2 mm in dia. A small hole is drilled into the workpiece and the wire electrode is threaded through the workpiece onto a take-up roll. The movements of the work table through computer numerical control in X and Y directions enable cutting the component to the required shapes. In some cases where a relief is required for the die or the punch being machined, a 3-axis NC is used to tilt the wire axis relative to workpiece surface in the required direction. The direction of tilt varies with the contour and is controlled by the third axis of the CNC. Some of the latest wire EDM machines have the automatic drilling and self threading facility.

## 12.4.6 TURRET PUNCH PRESS

CNC has become very popular with punching and nibbling machine used for sheet metal work. Many of these machines are equipped with a turret head. Such machines are called turret punch presses. This machine is widely used in press shops. Main application of the turret punch press is to cut various types of holes/openings in sheet metal for manufacturing machine frames or control cabinets out of sheet metal. Modular tooling systems available simplify tooling. Interactive programming facilities are available with the machine controls. Off line programming and simulation are adopted to utilize the machine fully and to obtain correct workpiece. Some of the turret punch presses have an additional plasma arc or a laser cutting head to generate contoured patterns. Some of the latest machines have automatic work handling, automatic tool change and automatic measuring systems interfaced with the machine. CNC has also been applied to other forming machines such as plate bending, tube bending, flow turning and stretch forming as well. Table 12.8 gives specifications of a typical CNC Turret Punch Press.

**Table 12.8 Specifications of a Typical Turret Punch Press**

Sheet size with one reposition	2040 x 1540 mm
Axis speed	40 m/min
Max sheet weight	75 kg
Max material thickness (MS)	6.35 mm
Punching accuracy	+/-0.13 mm
Turret layout	15 stations
Nibbling rate	180 hmp
Max hit rate @25 mm increments	180 hmp
Ram stroke	25 mm
Minimum material thickness	0.8 mm
Press motor	4.5 kW
Axis drive	AC servo
Clutch	Air combination
Brake	Air combination
Weight	8100 kg
Regrinding life of punch	10 mm

### 12.4.7 GEAR CUTTING MACHINES

CNC has been introduced to automate various types of gear cutting machines.

- Gear Hobbing Machines
- Gear Shaping Machines
- Gear Grinders
- Bevel Gear Generators

CNC enables elimination of change gears in gear cutting machines. The relative rotary and translation movements of the tool and the workpiece are controlled by CNC systems and can be easily programmed through keyboard of CNC system to facilitate quick setting up of the machine. CNC gear cutting machines employ the concept of an electronic gearbox. CNC increases both the productivity and accuracy of gear cutting machine appreciably.

Three to six-axis control is very common in CNC gear hobbing machines. Many CNC gear hobbing machines incorporate direct hob drives, automatic hob shift, quick-change hobs, and automatic hob head swiveling. High-speed hob spindles make effective use of multi-start TiN coated, carbide coated or carbide insert hobs. Table 12.9 gives specifications of a typical Gear Hobbing Machine.

Use of CNC in gear shaping machine eliminates the need for change gears. CNC control is provided for the axial movement of cutter head slide, radial movement of column slide, rotary movement of cutter spindle and rotary movement of worktable.

**Table 12.9 Specifications of a Typical Gear Hobbing Machine**

Max dia of workpiece	200 mm
Max module in steel	6 mm
Max axial travel	250 mm
Min/max no. of teeth	6/120
<b>Working range</b>	
Dia of work table/bore	215/60 mm
Distance between hob and work axis	220 (max): 20 (min)
Max dia. of hob	150 mm
Max length of hob	220 mm
Max hob shift	170 mm
Max helix angle	45 deg
<b>Speeds and feeds</b>	
Hob speed	120-500 rpm
Work speed	50 rpm
Axial feed	1-3000 mm/min
Radial feed	1-3000 mm/min
Tangential feed	1-540 mm/min
Hob swiveling	1-500 deg/min
CNC system	6 axes CNC control system, Sinumerik 3GA with electronic Gear box for synchronization
<b>Power</b>	
Main motor	12.5 kW

#### 12.4.8 CNC PRESS BRAKES

A press brake is basically a sheet bending machine. This machine finds extensive use in fabrication of control panels, enclosures etc. Provision of CNC increases the productivity and significantly improves the quality of the final product. CNC systems of press brakes provide interactive help for programming. A tool library is also provided. Simulation capability in the programming software helps in the development of correct programs.

#### 12.4.9 SPECIAL PURPOSE CNC MACHINES

Many SPM's are now designed with computer numerical control to provide the necessary flexibility to the machine. A typical example is a moving column SPM that is designed for boring and reaming operations. Under the guidance of CNC the tool is positioned at a desired point or the tool is made to follow any contour for machining operations. Switch over from one type of machining operations to other is completely automatic through the provision of Automatic Tool Changer (ATC). The column traverse and fixed table module contribute to higher transfer efficiency and flexibility in line production. Hence these CNC special purpose machines can be integrated with other machine tools into flexible manufacturing line for greater flexibility in producing a variety of totally finished

components. Table 12.10 gives specification of a moving column SPM. CNC is also used in transfer lines today.

**Table 12.10 Specifications of Moving Column SPM**

<b>Traverse</b>		
Saddle	X-axis	630 mm
Spindle head	Y axis	400 mm
Column	Z axis	500 mm
<b>Feeds</b>		
Rapid traverse	all axes	14000 mm/min
Feed rate	all axes	14000 mm/min (step less)
<b>Spindle</b>		
Spindle Taper	BT 50	
Speed	Infinitely variable	
Range	120-3000 rpm	
Power	7.5 kW	
Type of motor	Variable Speed AC	
Spindle thrust	1000 kg	
<b>Automatic Tool Changer (ATC)</b>		
Tool capacity	12 (nos)	
Maximum tool diameter	100 mm	
Maximum tool length	270 mm	
Tool changing time	8 sec	
Tool Selection	Random bi-directional	
<b>Accuracies: (JIS)</b>		
Positioning accuracy	+/- 0.012	
Repeatability	+/- 0.006	
<b>Hydraulic power pack</b>		
Motor power	3.7 kW	
CNC system	SINUMERIK 3M	
Power requirement	35 KVA	

#### 12.4.10 Other CNC Machines/ Accessories

CNC is used to control several other machines. Some of them are:

- i. Horizontal / Vertical boring machines
- ii. Jig boring and jig grinding machines
- iii. Plano millers
- iv. Co-ordinate measuring machines
- v. CNC welding machines

- vi. Assembly machines
- vii. Printed circuit board drilling machines
- viii. CNC forming machines
  - Tube bending machines
  - Plate bending machines
  - Stretch forming machines
  - Flow forming machines
- ix. Tool handling systems
- x. Work handling systems
- xi. Cleaning and washing stations
- xii. Heat treatment equipment
- xiii. Packaging equipment
- xiv. Electron beam welding machine
- xv. Fettling machines
- xvi. CNC press brakes
- xvii. Laser cutting machines
- xviii. Water jet cutting machines.

#### **12.4.11 USE OF CNC MACHINES AS INSPECTION MACHINES**

Since CNC machine slides are fitted with feedback devices, they can also be used for post process metrology. Many of the present day machines are fitted with touch trigger probes, which can be used for inspection of workpiece and for setting the tool offsets. On machining centres the probe can be stored in one of the pockets of the tool magazine. The probe is inserted into the spindle under program control and then can be used like a co-ordinate measuring machine to inspect the component being machined.

The probe can be used to compensate for fixture offsets, thermal deformations etc. A similar probe located at a fixed reference point can be used to set the offsets of the tools located in the spindle. Such probes are also used on turning machines to set the tool offsets and for monitoring the size of the workpiece.

#### **12.5 FEATURES OF CNC SYSTEMS**

The brain of a CNC machine is the control system. This is designed around one or more of the advanced microprocessors. Because of the advancement in the hardware technology, CNC systems are highly reliable with a very high mean time between failures. Several control systems, which are dedicated to different families of machines, are available today. Each model will have several variations to cater to the various requirements of machine tool builders and users. Several new CNC systems are fitted with PC based CNC systems too. A CNC system can be fitted to machine tools in order

to effect control over several machine functions. In order to perform these functions, a CNC system is characterized by a number of features. These functions can be broadly classified as follows:

- i. Control system features
- ii. Memory features
- iii. Programming features
- iv. PLC features
- v. Diagnostic features

### 12.5.1 CONTROL SYSTEM FEATURES

These features provide information about the characteristics of the CNC system and its capabilities. Important features are given below:

#### 12.5.1.1 Technology of System

Currently two types of architectures are being used in CNC systems

- (i) Single microprocessor based systems
- (ii) Multi microprocessor based systems (Multiprocessor systems)

**Single microprocessor architecture:** In this type of system a 16, 32 or 64 bit microprocessor is used.

**Multiprocessor architecture:** This type of the architecture is widely used in many CNC systems today. The control functions are carried out by a set of microprocessors, each doing an assigned task. This concept helps to implement various functions faster. Both hardware and software structures are modular thereby enhancing the flexibility of the system.

#### 12.5.1.2 Executive Program

The executive program contains the intelligence needed to carry out different tasks in CNC system. The executive program is resident usually in EPROM/Bubble memory.

#### 12.5.1.3 Other System Features

Other features of CNC system are:

- C R T display and alphanumeric keyboard
- Manual data input (M D I) and operator programming
- System resolution, ex: 0.1  $\mu\text{m}$ , 0.5  $\mu\text{m}$ , 1  $\mu\text{m}$  or 10  $\mu\text{m}$
- Feed and rapid traverse rates
- Spindle Speeds - directly programmable or through S codes
- Modes of operation like M D I, Single step, Auto etc.
- Operating controls like Jog, feedrate and spindle speed override, axis select switch, edit, reference, dry run, test mode

#### 12.5.1.4 Axis Calibration

This is a very useful feature for obtaining higher positioning accuracy. The error in the pitch of the lead screw can be compensated with this feature.

#### 12.5.1.5 Reversal Error (Backlash) Compensation

Backlash is due to the play between the screw and nut. Backlash will cause lost motion when the slides are reversed. Even pre-loaded ball screws may develop backlash in the course of time. This feature effects automatic compensation every time the slide is reversed. Error due to backlash in the lead screw can thus be minimized.

#### 12.5.1.6 Pitch Error Compensation

There are several classes of accuracy for ball screws. There will always be some error from pitch to pitch, however accurate the screw may be. Pitch error will cause error in positioning as well as thread cutting. Hence there is a need to compensate pitch error. The positioning errors that might arise due to error in pitch are compensated through software.

#### 12.5.1.7 Tool Nose Radius Compensation

The radius of the tool will introduce positioning errors in contouring. This error is compensated by the tool nose radius compensation function.

#### 12.5.1.8 Machine Setup Data (MSD)

MSD or machine tool parameters indicate the machine tool characteristics, specifications and functions. The contents of each parameter should be set according to the parameter list annexed to the machine. The end user must not change the contents on the parameters. The OEM can use one standard control on several machine sizes and/or types.

Entering machine parameters: These are three methods of entering machine parameters.

- i. Setting through parameter CD-ROM-each block contains a machine set up data code to identify the machine parameter followed by data for that parameter.
- ii. Setting data through MDI - the machine data can be input through the operator's control panel by following the procedure for the control system.
- iii. Setting data in EPROM's - machine parameters can be entered in the erasable programmable read only memories. The data is permanently stored in specific locations in the memory chip. To enter the set up data in EPROM, an EPROM programmer is necessary.



### 12.5.2 MEMORY FEATURES

<i>Design</i>	<i>Application</i>	<i>Features</i>
Executive storage	EPROM	Non- volatile and widely used
Part program storage	Dynamic RAM CMOS RAM Bubble memory	Semi conductor memory Fast access and volatile Nonvolatile, slower than semi-conductor memory
Machine constant	EPROM	Nonvolatile and can be field programmed. Needs battery back up
Memory (parameter)	CMOS RAM	Intermediate working
Scratch pad RAM Static RAM area	MOS RAM	
Off-line data storage	Magnetic digital cassette Magnetic disc Floppy disc Hard disc CD-ROM	

### 12.5.3 PROGRAMMING FEATURES

Some standard programming features include:

- Absolute/Incremental programming
- Decimal point programming
- Diameter/Radius Programming
- Linear, circular and helical interpolation
- Multiple part program storage
- Sequence number search
- Feed/min or feed/rev Programming
- Dwell programming (In block containing dwell code, there is no slide movement)
- Tool length and diameter compensation - The control has a storage area (tool buffer) for making modification to the program due to errors in tool setting length and diameters
- Position preset.

#### 12.5.3.1 Subroutine Programming / Macro Programming

Repetitive operations can be written as subroutines and main program can call these subroutines. An example of subroutine is dressing program for a grinding wheel. The

advantage of using this subroutine is that it eliminates the need for rewriting a repetitive operation, thereby saving the memory space.

### 12.5.3.2 Parametric Programming

Parameters are freely assigned by the control for the purpose of arithmetic calculation in a part program. Trigonometric operations are also possible with R parameters.

### 12.5.3.3 Canned Cycles (Fixed Cycles)

This is a powerful control feature intended to shorten the length of the part program thereby conserving memory space. Canned cycles are single block multi pass fixed cycles.

**Examples:** Canned cycles for rough turning and peck drilling in CNC Lathes. Canned cycles for drilling, boring and tapping in machining centres.

## 12.5.4 PROGRAMMABLE LOGIC CONTROLLER

Programmable logic controller is a software oriented machine interface between the CNC system and machine tool functions such as miscellaneous functions (coolant on / off, pallet operation, spindle speed functions (M00, M01, M03, M04, etc) and tool functions). Signals from CNC to PLC are on /off type. The programmable logic controllers available today are microprocessor-based units, which are integrated into the CNC system. The programmable logic controllers have memory space to store interface programs.

Some of the common P L C features are listed below:

- Number of inputs and outputs 24, 32, 48 etc., (Both analog and digital)
- Memory capacity 4 k, 8 k etc.
- High-speed microprocessor to execute sequence program processing time of the order of milliseconds
- Software timers and counters
- Data exchange between CNC and PLC

## 12.5.5 DIAGNOSTIC FEATURES

The CNC systems have diagnostics features for faults or error conditions. Diagnostics are software programs, which check the functioning of the CNC system at various levels. The control system manufacturer gives detailed use and applications of these diagnostic programs. Diagnostics can be grouped as follows:

- i. Real time diagnostics
- ii. On-line diagnostics
- iii. Off-line diagnostics

### **Real Time Diagnostics:**

D C power supply voltages, low voltage and real time clock are monitored. In case of failure of any one of these, control system automatically assumes the emergency stop conditions and shuts down the drives.

**On-line Diagnostics:**

On-line diagnostics are active during machine operation. Diagnostic messages are either readable from C R T screen or from LED Indicators. Program diagnostics detect programming errors. (Syntax, Parity etc.)

**Off-line Diagnostics:**

It is provided in the form of a CD-ROM or ROM board (PCB). Following a malfunction, the off-line diagnostic programs are to be loaded which check the different areas of the system and respond with error codes / error description on C R T Display. Diagnostics are very powerful features of CNC systems. To be productive, the system should have a low MTTR (Mean Time to Repair).

**Remote Diagnostics:**

It is now possible to send diagnostic programs through Internet to check the errors in CNC Machines. This enables manufacturers to locate faults even if the machine is located in a remote place in another country.

**12.5.6 SOME FEATURES OF MODERN CNC SYSTEMS**

- (i) **Advanced hardware architecture:** Custom built very large scale integrated circuits (VLSI) which can handle several functions in a single chip are used in modern CNC systems. This way, the benefits of reduced component count and improved reliability are realized.
- (ii) **Software modularity:** Each function is written as a discrete module - (structured programming). Additional software features can be added at any time to upgrade the control without affecting the software.
- (iii) **Adaptive control:** Reduces the production time by maximizing the utilization of the machine tool. It acts on measurement taken from external sensors (In-process measurement) and modifies the cutting conditions suitably.
- (iv) **Conversational programming:** The system featuring conversational programming are termed "user friendly" since they are designed with the operator in mind. One example of such a friendly feature is graphic display. With this feature, the operator can create the part drawing on screen and simulate the tool paths in the preparatory phase (Prior to machining). The operator can program in complete safety and be sure that nothing is omitted. The operator can also check the correctness of the part program on graphic display.
- (v) **Programming flexibility:** In addition to conversational part programming language, high level language commands like IF-THEN ELSE, GO TO etc., can be used to extend the program's power. Higher mathematical functions can be used to calculate square roots, trigonometric functions etc.
- (vi) **DNC link.** This is discussed separately in detail later.

- (vii) **Colour graphics:** This provides visual interface between the operator and CNC. Part cross sections can be highlighted. Operating instructions and warning display can be colour coded for more clarity.
- (viii) **Machine interface:** A high-level language like C is used for programming the machine logic in PC (example: GE 2000 MC). In AB8600, high-level language SIPROM (System Interface-Programming) is used.
- (ix) **Automatic selection of cutting speeds:** If we specify the tool material and work material, C N C System selects cutting speed and feed from cutting condition technology database.
- (x) **Automatic selection of tools and sequencing of tools:** If operation is specified, system selects corresponding tools and sequence of tools. Systems like Mazak Fusion 640 provides this knowledge based approach.
- (xi) **Optimization of machine program:** This feature will be useful for components with large number of drilling, tapping operations, or repetitive end milling tool paths as in the case of machining of dies and molds etc.
- (xii) **Display of finished component:** Today CNC systems offer a feature to display the finished component together with dimensions. Sectioning and rotation of the model of the finished part are also possible.
- (xiii) **Background programming:** It is a common facility available in CNC systems. The user can run, edit and simulate another program while a program is being executed on the machine tool.
- (xiv) **Digital CNC:** The new breed of CNC controls use digital technology. The introduction of digital CNC has brought increased speed and precision to machine tool builders. The PC based open architecture controls incorporate such features like acceleration with jerk limitation, direct NURBS interpolation, use of high level languages, execution of large CNC programs from hard disc and increased number of zero offsets. In some of the systems the CNC and drive amplifiers are on the same board at the digital level.
- (xv) **Look ahead feature:** The control system scans 150 or more blocks ahead of the block that is being executed and carries out interpolation and calculates the acceleration and deceleration requirements in the case of generation of complex tool paths. This helps to produce accurate profiles in high speed machining.

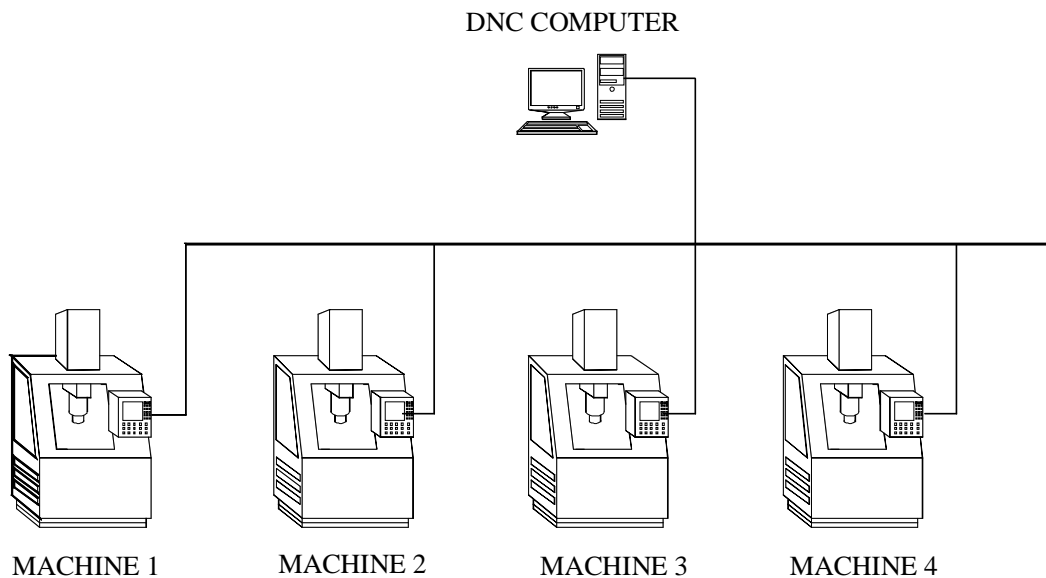
## 12.6 DIRECT NUMERICAL CONTROL (DNC)

Early NC machines used a tape reader for storing and inputting the program into the memory of the NC machine tool. Because of the unreliability of the tape reader as well as the low speed of operation NC engineers were searching for a suitable alternative. The advent of CNC in mid-sixties opened up the possibility of improving the performance of NC machines by interfacing them with minicomputers. Yet another significant technological development was the interfacing of several NC machines with a computer,

which can store the part programs and transfer them to the NC machine concerned as and when needed. The computer is connected between the tape reader and the NC machine thereby bypassing the tape reader. This system was therefore called as behind the tape reader system (BTR). This development became very popular with NC machine users because of a number of significant advantages.

- i. A number of NC machines can be connected to a single computer. In many cases a single computer can manage all the machines on a shop floor.
- ii. Programs in full or in segments can be transferred to the NC machines in a multiplexing mode.
- iii. The computer can be conveniently used for program editing.
- iv. Since the computer has large memories there is no limitation on the number or size of programs stored.
- v. The computer can be used for other tasks like program creation using computer aided part program generation software as well as for operation management tasks like production planning, scheduling etc.

With the development of CNC, DNC concept was extended to CNC machines also mainly for part program management. The DNC computer (sometimes referred to as host computer) could serve a number of CNC machines in shop floor. Figure 12.19 shows a typical DNC network. The DNC computer stores all the part programs and transfers the part programs to the CNC machines in response to the requests of the operators.



**Fig. 12.19 DNC System**

DNC systems are generally designed for 4, 8, or 16 CNC machines. However, with the wide spread acceptance of the local area network concept, the possibility of connecting more CNC machine in a DNC network has become a reality. The concepts of Internet, Intranet and Extranet have further enlarged the scope of distributed numerical control.

### 12.6.1 OBJECTIVES OF DNC

DNC serves many purposes and is now considered as essential for the efficient management of CNC machine tools in the shop floor. The main objectives of implementing DNC are given below:

1. Upload and download CNC programs to and from machine tools simultaneously and directly from the CNC systems.
2. Easy editing of the existing programs.
3. Eliminating the use of manual switch boxes to multiplex CNC machines.
4. Organizing and cataloguing of all programs for instant access.
5. Eliminating the need for manually punching the program at the keyboard thereby saving considerable costly machine time.
6. Eliminating the need for paper tape in the old generation of NC machines.
7. Copy programs to and from the floppy discs and other media to the DNC computer.
8. Compare files edited at the CNC to the original program.
9. Rename or delete or update programs or create new programs.
10. Show pictures of set ups for graphic catalogue of set up and machining operations.
11. Providing system transaction files of all activity on the DNC computer.
12. Pass word protection at different points of the CNC system wherever the operator could cause damage to the NC code by overwriting.
13. Tool length offsets from tool pre-setters can be transferred directly to machine tool controls. It is also possible to connect co-ordinate measuring machines to DNC networks.

### 12.6.2 A TYPICAL SCREEN OF A CNC SYSTEM

A typical program transfer screen for a DNC system with 4 machines is shown in Fig. 12.20. Besides send and receive, this screen has an option **Close** that stops the communication in progress. The option **Edit** loads a file into the editor. **Compare** enables the operator to see the difference between a files edited at the CNC system against the original file sent to the machine. The option **Picture** enables the user to see shop floor graphics.

### 12.6.3 BAR CODE OPTION

Some DNC systems provide an RS-232 bar code reader that is installed at the CNC system which enables the user to bar code the remote requests to receive and send files at the CNC. This eliminates typing and possible mistakes.

SEND	RECEIVE	CLOSE	EDIT	FILES	COMPARE	PICTURE	EXIT
SEND A FILE TO							
COMMUNICATION STATUS WINDOW							
MACHINE NAME	FILE NAME	STATUS	SENT/RECEIVED				
ACE JOBBER	94432145	SEND	68 %				
DMG VMC	73241561	RECEIVE	34 %				
DMG HMC	54321456	SEND	96 %				
MIKRON	12356432	SEND	09 %				

*Fig. 12.20 Program Transfer Screen*

#### 12.6.4 FILE MANAGEMENT SYSTEM

A DNC system will have a file management system, which has the following features:

- i. Store and display details like file name, date of creation or updating of the file, time of creation of the file size etc.,
- ii. Files can be picked by mouse or arrow keys.
- iii. The facility for the use of long description will help easy recognition of the workpiece from the program name.
- iv. Files can be sorted in the ascending or descending order by date/time, size or long description.
- v. Files can be copied, moved or deleted.

A typical Editor screen is shown in Fig. 12.21

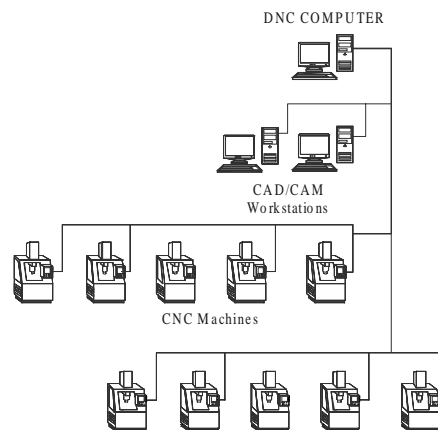
FILE NAME	LONG NAME	SORT	TAG	<OFF>	ACCEPT
C:\DNC\NC FILES[Use Mouse to Toggle Menu]					
03450.NC	28-09-04	08:45	BRACKET		
12987.NC	30-10-04	12:34	RING		
675849.NC	05-12-04	14:50	BULKHEAD		
214365.NC	21-02-05	11:15	SPAR		

**Fig. 12.21 Editor Screen**

Another feature of DNC is a provision for creating a report file, which is listing of all activities on the computer that is constantly written in the background. This is an ASCII file, which can be exported to databases for MIS purposes.

### 12.6.5 INTEGRATION OF CAD/CAM SYSTEM WITH DNC

Nowadays CAD/CAM systems are widely used to generate CNC programs. The CAD/CAM system can be linked to the DNC computer so that the programs created by the CAD/CAM system can be transferred to the DNC computer for routing to the proper CNC machines or for editing. A typical LAN, which includes a DNC system and a CAD/CAM workstation, is shown in Fig. 12.22.



**Fig. 12.22 CAD/CAM System in a DNC Network**



### 12.6.6 DISTRIBUTED NUMERICAL CONTROL

Sometimes the abbreviation DNC is used to denote distributed numerical control. A computer network for manufacturing may consist of a main frame computer, CAD/CAM work stations, DNC host computer and the CNC systems connected to it. This configuration can be beneficially used for NC data processing. Any complex calculations required for generating NC data can be transferred to the more powerful mainframe computer. Thus the NC DATA processing is done at different hierarchical levels. In a way many of the DNC systems to day are in fact distributed processing systems.

### 12.6.7 FUNCTIONS OF A DNC SYSTEM

The functions of a DNC system can be summarized as below:

- i. Part Program management: Part program stored in the hard disc can be routed to appropriate machines in the network depending upon the schedule.
- ii. Shop floor editing: Program can be edited or modified to take into account design changes, tool changes or machine changes.
- iii. Shop floor graphics: The tool path simulation can be carried out on the shop floor.
- iv. Data collection: The DNC computer can be used for shop floor data collection for scheduling and monitoring.
- v. Shop scheduling: Since NC program despatch is interlinked with the schedule, the DNC computer can be used for scheduling.
- vi. Statistical Process Control (SPC): The SPC function can be integrated into the working of the DNC computer as it can be interfaced with the shop floor data collection function.
- vii. Tool offset management: Tool offset data is sent to appropriate machine by this function.

The DNC network systems are usually UNIX, Novell or Windows based. They have multitasking capabilities and Ethernet, arcnet or token ring interfaces. They may also have limited CAD/CAM capabilities. Efficient built-in security systems will take care of unauthorized access.

### 12.7 FUNCTIONS AVAILABLE IN A TYPICAL CNC SYSTEM

The functions available in a popular CNC system are listed below:

- |       |                                       |                 |
|-------|---------------------------------------|-----------------|
| (i)   | Controlled axes                       | 2, 3, 4, 5 etc. |
| (ii)  | Simultaneous axes                     | 2, 3, 4, 5 etc. |
| (iii) | Max. programmable dimensions          | 7 digits        |
| (iv)  | Linear Interpolation                  |                 |
| (v)   | Multi-quadrant circular Interpolation |                 |

- (vi) Thread cutting
- (vii) Rapid traverse
- (viii) Feed rate override
- (ix) Rapid traverse override
- (x) Auto acceleration and retardation
- (xi) Exact stop
- (xii) Dwell
- (xiii) Reference point return
- (xiv) Co-ordinate system setting
- (xv) Decimal point input
- (xvi) X axis dia./radius programming
- (xvii) Radius programming
- (xviii) S, T, M codes
- (xix) Program number display
- (xx) Program number search
- (xxi) Program/subprogram
- (xxii) Program format
- (xxiii) Optional block skip
- (xxiv) Canned cycles
- (xxv) No. of offsets
- (xxvi) Backlash compensation
- (xxvii) Cycle start/Feed hold
- (xxviii) Reset
- (xxix) Manual continuous feed
- (xxx) Incremental feed
- (xxxii) Machine lock
- (xxxii) Dry run
- (xxxiii) Single block
- (xxxiv) Registerable programs
- (xxxv) Variable tape storage length
- (xxxvi) Data protect
- (xxxvii) Self diagnostics
- (xxxviii) Emergency stop
- (xxxix) Stored stop check
- (XL) PMC (programmable machine control)
- (XLi) Spindle speed
- ( XLii) T N R C (Tool Nose Radius Compensation)
- ( XLiii) Custom macros

(XLiv) Run Hour/Part display.

## 12.8 STANDARD CONTROLLERS

There are large number of manufacturers of CNC controllers. Some of those listed below may not be in production today.

- (i) Acramatic
- (ii) Aciera CNC
- (iii) AEG
- (iv) Allen Bradley
- (v) Anilam
- (vi) ASEA
- (vii) Bendix
- (viii) Bosch, 860, 880, alpha 2, alpha 3, CC 100, CC 200, CC 300, CC 330 Bosch micro 5Z, 8Z, PC (PG), system 5
- (ix) Boehringer B1 T, B2 T
- (x) Charmilles Robofill
- (xi) Cincinnati
- (xii) Deckel CNC 2301, contour, FP2-FP4
- (xiii) DeVlieg
- (xiv) Dixi NC
- (xv) Emco-Turn
- (xvi) ESAB NCE 301
- (xvii) FANUC, 0M, 0T, 3TF, 3M, 3TF 3T, 5M, 6MB, 6MA, 7M, 7T, 9, 10, 11, 12, 15, 20, 20A, 2000, 3000, MATE L, MATE M, MATE TS
- (xviii) Fidia
- (xix) GE 550, 1050, 1050HL OX, 7542, CNC2000.
- (xx) Gildemeister EPL, EPM(UNI), EPM(ITY), EPM(SET), EPM II (BTR) 22
- (xxi) Heidenhain TNC 135, 145, 151, 155, 355, 455
- (xxii) Heller Unipro 80
- (xxiii) Hurco Ultimax B M C40
- (xxiv) Kongsberg NC 300, NC 2000
- (xxv) MAHO 432
- (xxvi) Mandelli
- (xxvii) Mazak M1, M2, M32, T1, T2, T3, T4, T32
- (xxviii) Meldas 5000
- (xxix) NUM 560, 750

- (xxx) Okuma OSP 330 D, OSP 2000, OSP3000, OSP5000
- (xxxi) Olivetti Contour
- (xxxii) Philips 432, 3300, 3353, 6600, 6652.
- (xxxiii) Sinumerik Mate TG, PRIMO S, SPRINT T, SPRINT 3T, 3M, 5M, 5T, 6MA, 6TA, 6MB, 6TB, 7M, 7T, 520, 550C, 560K, 810, 820, 850
- (xxxiv) Traub TX 7, TX8, TX8D
- (xxxv) Toshiba
- (xxxvi) Yasnac 3000
- (xxxvii) Fagor

Fanuc, Sinumerik and GE-Fanuc are the most popular CNC system manufacturers today.

## 12.9 SOME OF THE FEATURES AVAILABLE IN TYPICAL HIGH END CNC SYSTEM

Recently a new generation of CNC controllers have been marketed by several manufacturers. Some of their important features are:

- (i) **Automatic determination of optimum tool path:** By using data that is interactively input to define the workpiece contours artificial intelligence is employed to determine the optimum approach point and tool path to eliminate unnecessary tool movement. As a result, the overall machining cycle is minimized.
- (ii) **Feed spindle orientation:** By the use of a digitally controlled AC spindle motor, spindle orientation is fast and precise.
- (iii) **Automatic feedrate override:** Even though only one feedrate is programmed for a machining cycle such as a pocket milling, the optimum feedrate for both the in-feed direction and corner cutting is automatically determined. Also when milling pockets, the feedrate is automatically changed when machining with full cutter width and when machining with partial cutter width to maintain the optimum cutting conditions for the minimum machining time.
- (iv) **Simultaneous S, M and T functions:** Simultaneous operation of different units, such as the ATC and Machine table indexing, A T C and pallet changer can be performed to greatly reduce machine's non-cutting time.
- (v) **High speed tapping:** The digitally controlled spindle motor allows spindle rotation and Z axis feed to be synchronized. This advanced design makes high speed, high precision tapping possible without the use of the floating tap holder. This is also referred as rigid tapping.
- (vi) **High speed cutting of complex contours:** For complex contours that require interpolation by extremely small increments, the faster processing of speed of the 32 or 64 bit processor results in a much higher vectorial feed rate than that of conventional CNC systems.

- (vii) **D N C interface:** The 32 or 64 bit CNC mounted on a machine can be linked with a host computer and transmit and receive data. By DNC interface, information can be shared.
- (viii) **MAP compatibility:** The 32 bit CNC controllers is designed for MAP (Manufacturing Automation Protocol) compatibility - the international communication standards to be used by equipment in an automated factory.
- (ix) **Background communication:** The high speed 32 bit microprocessors can handle communications of variety of data - programs, parameters, tool data and programs with a host computer simultaneously while in automatic operation.
- (x) **Absolute position detection:** If equipped with absolute position detection function, a machine does not have to return to the home position prior to beginning operation. This is especially advantageous for a machining center controlled by host computer.
- (xi) **Tool life management, Tool breakage detection and recovery:** These functions resident in the individual machine's memory can be communicated with the host computer, thereby facilitating centralized tool management.
- (xii) **Automatic centering:** By the use of a touch sensor mounted in the spindle, measurement of datum holes and surfaces is performed. Based on the measurement results, the work co-ordinate system is automatically shifted and machining begins.
- (xiii) **Adaptive feed rate control:** By continually monitoring the load on the spindle motor and Z- axis servo motor, optimum cutting conditions are maintained. When an overload condition is detected, the programmed feedrate is automatically overridden. As the cutting load becomes smaller, the feed rate will automatically return to the programmed value.
- (xiv) **Process management and program layout displays:** The interconnections between processes and subprograms and processes with commonly used tools are indicated on these displays for convenient program restarts.
- (xv) **Automatic tool length measurement:** Tool length can be automatically measured and registered in memory to greatly reduce tool setting time. One setting of the measurement cycle allows up to 13 tools to automatically processed. (This process is semi-automatic for face mills and boring bars in that the tool must first be manually positioned over the measurement unit).
- (xvi) **Workpiece co-ordinates:** When using a tool (such as an edge finder) to establish a workpiece datum point, all that is required is to enter the tool radius. The necessary calculations are performed automatically to set the workpiece zero position. When the optional touch sensor is used the angular offset co-ordinates can also be set. This allows high machining accuracy to be obtained even with simple fixtures.

- (xvii) **Tool path storage:** The tool path storage function can be used to store in memory the point where a tool breaks during the cutting plus the path used to retract the cutter for servicing. This allows fast and smooth program restarting.
- (xviii) **Automatic cutting conditions editing:** Programmed spindle speeds and feed rate are easily altered by override keys according to actual machining conditions. By pushing an appropriate key, the programmed cutting conditions are automatically edited by the override amount on an individual tool basis.
- (xix) **Modal information display:** The modal information display indicates which G, M, S, f codes are effective. This is extremely convenient for error-free restart of EIA / ISO programs.
- (xx) **Deflection compensation:** Automatic compensation can be performed for the displacement at one axis in relation to another axis used as the datum.
- (xxi) **Large reduction of component parts:** With a 32 or 64 bit microprocessor as the core, large capacity memory chips, custom LSI's and other state of the art technology used to the maximum, the number of parts is considerably smaller than that of conventional CNC system resulting in a highly reliable and compact design.
- (xxii) **Ladder circuit display:** The open and close status of individual circuits are displayed on the ladder chart on CRT display to help pinpoint the cause of problems.
- (xxiii) **Optimization of cutting conditions:** Several CNC systems access cutting tool databases as well as cutting parameter databases. The interactive programming facilities enable the operator of the machine tool to input the features of the drawing in the CNC system. The system responds with appropriate tool selection and cutting parameter selection. Techniques are also incorporated to optimize the parameters.

## 12.10 GENERAL PROGRAMMING FEATURES OF CNC SYSTEMS

CNC systems can be classified into:

- (i) CNC Systems for machining centres
- (ii) CNC Systems for lathes and turning Centres
- (iii) CNC Systems for special applications like Grinding Machines, EDM, Electron beam welding etc.

There are many features in these CNC systems which are of general interest and some of them are discussed below:

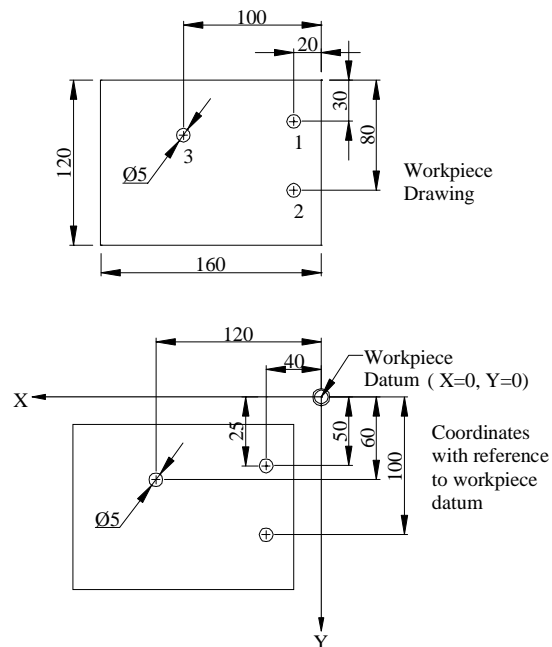
**Absolute and Incremental Programming:** Figure 12.23 shows a plate in which 3 holes are to be drilled. The locations of the holes are indicated in the drawing of the component. For the purpose of programming, these dimensions should be specified with respect to the workpiece coordinate system.

The X and Y axes are to be defined first. Figure 12.23 shows the X and Y axes at a distance of 20 mm from the edge of the plate. The coordinates of the three hole locations should be calculated with respect to these axes.

In the case of absolute coordinate system all the coordinates should be specified with respect to the workpiece datum. In the case of incremental system, the zero datum is a floating one. Every coordinate is specified with respect to the previous position.

For machining the three holes the slide should be positioned under the drill spindle successively in positions 1, 2 and 3. The reference axes are marked in the figure. Thus the absolute co-ordinates to be used in the program will be:

<b>Position</b>	<b>X</b>	<b>Y</b>
1	40	50
2	40	100
3	120	60



**Fig. 12.23 A Plate with Holes**

There are three ways in which the co-ordinate data are input to the machine control. They are:

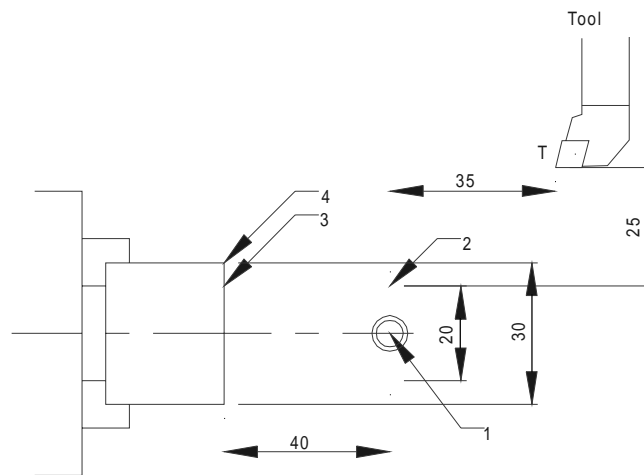
- i. Absolute mode
- ii. Incremental mode

## iii. Mixed mode

In absolute mode, all co-ordinate values are measured from a fixed datum. Referring to Fig 12.24, W is the workpiece datum ( $X = 0, Z = 0$ ). Points 1, 2, 3 and 4 have co-ordinates.

<b>Point</b>	<b>X</b>	<b>Z</b>
1	0	0
2	20	0
3	20	- 40
4	30	- 40

(Note: In programming CNC lathes, the diameter is input instead of radius)



**Fig 12.24 Co-ordinates in Turning**

In incremental mode, the co-ordinate data input for every movement is the relative distance from the previous point. For example, when the tool moves from point 3 to point 4, the X distance is +5 and Z distance is zero. Thus, the co-ordinates depend on the axis movements.

The co-ordinate distances in incremental mode for Fig. 12.24 are given below:

<b>Point</b>	<b>X</b>	<b>Z</b>
T to 1	- 35	- 25
1 to 2	+ 10	0
2 to 3	0	- 40
3 to 4	+ 5	0



In mixed mode, the co-ordinates can be either in absolute co-ordinates or incremental co-ordinates. Absolute co-ordinates are labeled X and Z and incremental co-ordinates U and W. For the example given, the co-ordinates can also be input as:

In mixed mode, the co-ordinates can be either in absolute co-ordinates or incremental co-ordinates. Absolute co-ordinates are labeled X and Z and incremental co-ordinates U and W. For the example given, the co-ordinates can also be input as:

<b>Point</b>	<b>Z</b>	<b>Z</b>
1	X0	Z0
2	U10	Z0
3	X20	W – 40
4	U+5	W0

In lathes it is convenient to program in mixed mode whereas in the case of machining centres program segments can be either in incremental or absolute mode or the whole program can be in either one of the modes.

#### ii. Preparatory codes and miscellaneous codes:

A typical line of a CNC program (called block) is given below:

**N 0040            G01            X100.05    Y180.95 S450 M08;**

Every block starts with a block number (3 or 4 digits), (N word); A block may have one or more G functions. G- functions like G01 if defined earlier and if the value is the same need not be repeated. For example, in a block if G01 is defined and if the next block also involves G01, this will be implied and need not be explicitly stated. Such G functions are called modal G functions. The block may contain the X, Y and Z co-ordinates of the target point. The feed at which the slide movement is to be executed is specified in the feed value. (e.g. F equal to 400 mm/min). If the feed is same as specified in the previous block it need not be repeated again. The spindle speed is specified by the S address. (e.g. Speed is 450 rpm). The M word represents a miscellaneous function. In this case M08 switches on the coolant motor. Thus each word has a unique alphabetic address. Hence this type of formatting the program is referred to as word address format. Other commonly used word addresses are T for tool, V for cutting speed, A for angle, etc.

G-codes or G functions are mainly NC functions. These are also called preparatory functions. Some of these have been assigned standard functions and others are left to be defined by the CNC system manufacturers. Common preparatory functions in a CNC system for lathes (FANUC 0) include:

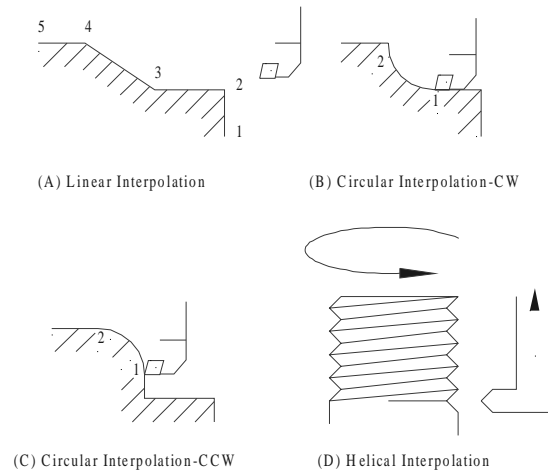
- (i) Interpolation functions
  - Positioning (G00)
  - Linear interpolation (G01)
  - Circular interpolation (G02, G03)
  - Polar co-ordinate interpolation (G112, G113)
  - Cylindrical interpolation (G107)

- (ii) Thread cutting (G32, G34)
- (iii) Feed functions
  - Feed per minute (G98)
  - Feed per revolution (G99)
  - Dwell (G04)
- (iv) Reference point
  - Automatic reference point return (G28)
  - 2nd, 3rd and 4th reference point (G30)
- (v) Co-ordinate system setting (G50)
- (vi) Inch-metric conversion (G20, G21)
- (vii) Constant surface speed control (G96, G97)
- (viii) Canned cycles
  - Outer diameter cutting cycle (G90)
  - Thread cutting cycle (G92)
  - End face turning cycle (G94)
- (ix) Multiple repetitive cycle
  - Stock removal in longitudinal turning (G71)
  - Contour parallel turning (G73)
  - Finishing cycle (G70)
  - Thread cutting (G76)
- (x) Canned cycles
  - Front drilling (G83)
  - Side drilling (G87)
  - Front tapping (G84)
  - Front boring (G85)
- (xi) Compensation function
  - Tool Nose radius compensation (G40 - G42)
  - Changing tool offset amount (G10)
- (xii) Measurement functions
  - Automatic tool offset (G36, G37)

M- Functions are mainly switching functions. These include spindle on/off, spindle rotation (clockwise or anticlockwise) coolant on/off, tool change, pallet change, turret indexing etc. Earlier, these functions were incorporated in the NC control itself. Nowadays, a separate programmable logic controller (PLC) interface is provided so that the machine tool designer can design his PLC program to incorporate unique control features. This allows considerable flexibility for the designer. Control of auxiliary devices like conveyors, robots, pallet loaders, bar feed systems, quick change of chuck jaw, automatic door open/

close, machining completion buzzer, automatic chuck operation, chuck air blast etc. can be easily integrated in the machine tools either by the manufacturer or by the user.

### iii. Interpolation

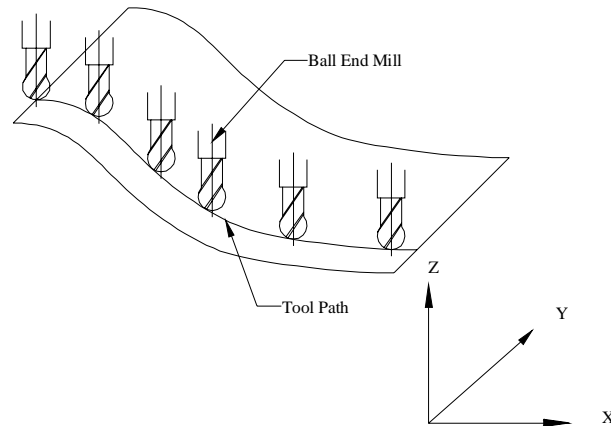


**Fig 12.25 Interpolation Methods**

The calculation of successive increments in slide position to reach the programmable point is called interpolation. Common methods of interpolation are linear, circular and helical. Figure 12.25 shows commonly used interpolation methods. Linear interpolation is shown in Fig.(A). Length 12 represents a linear movement parallel to X axis. Segments 2-3 and 4-5 are movements parallel to Z-axis. Segment 3-4 involves simultaneous movement in X and Z directions. Depending on the feed specified in the block the CNC system will calculate the individual speeds of the slides so that a taper will be cut on the surface of the workpiece. In Fig.(B) the segment 1-2 is turned using clockwise circular interpolation. It may be noted that the slide velocities in each axes will have to continuously vary to obtain the circular profile. This is also true with the counter clockwise (CCW) circular interpolation shown in Fig.(C). Helical interpolation used to cut threads in machining centers is illustrated in Fig.(D).

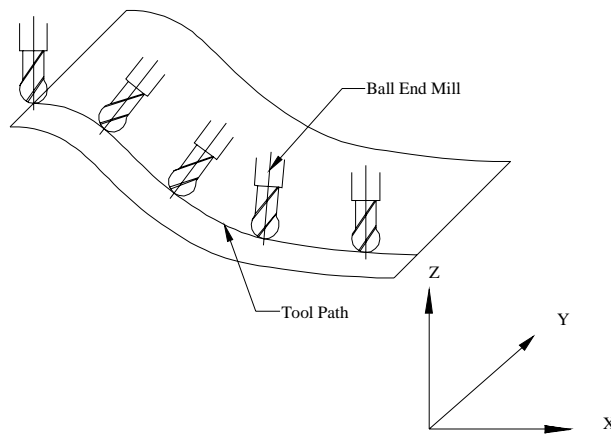
### iv. Axes of movement

A CNC machine tool may have several controlled axes. If simultaneous movements in 2-axes only are available, the control is called 2-axis control. The CNC lathe will have two axes i.e. X and Z. A turning center will have three axes i.e. X, Z and C. A machining center will usually have three axes (X,Y and Z).



**Fig. 12.26. 3-Axes Machining**

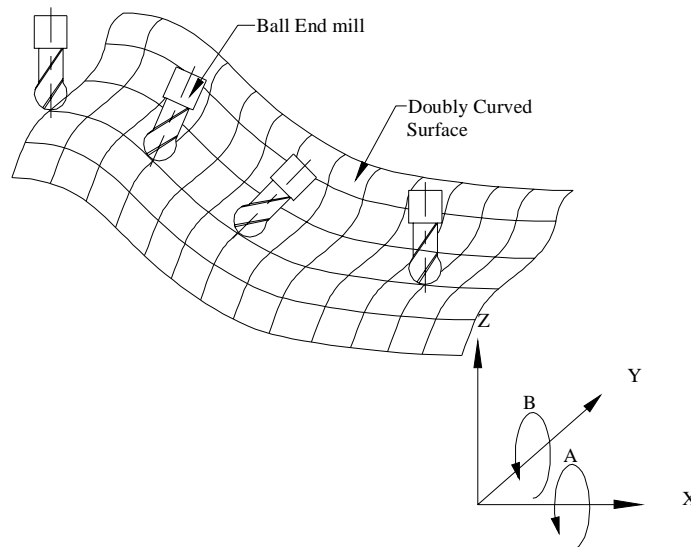
Figure 12.26 shows the machining of the surface of a component which requires control in three axes. For machining such curved surfaces a special cutter called ball end mill is recommended. The path of the cutter along one curve segment is illustrated in the figure. The cutter axis is always vertical. It may be noted that different points along the cutting edge cuts the surface depending on the curvature of the surface. Therefore, care must be taken to take into account the cutter radius during the interpolation For ensuring



**Fig. 12.27 4-Axis Machining**

better accuracy, an additional axis is needed in the case of such surfaces. This is shown in Fig. 12.27. in which 3 translational axes (X, Y & Z) and a rotational axis (A) are employed. At any point on the surface the tip of the cutter touches the surface and the cutter axis is aligned with the normal to the surface. To achieve this it is necessary to obtain the inclination of the normal to the surface and swivel the spindle about the X-axis by that angle. Machining of several aircraft components require control over five

axes A doubly curved surface shown in Fig. 12.28 requires 5 axes viz. X, Y, Z (translation), A (rotation about X) and B (rotation about Y). Tool is swiveled with respect to X axis as well as Y-axis so that the axis of the tool and the normal to the surface at the point of cut are collinear. Typical parts that require 5-axis machining are tools for pressing body panels of automobiles, bulkheads and other complex parts of aircraft, molds for plastic injection molding, die casting dies, mixed flow impellers, etc. Thus a 5-axis machine will have three translational axes and 2 rotary axes. The rotary axes are provided either on the spindle or on the table or one rotary axis on the table and another rotary axis on the spindle. Parts made in 5-axis machines will require very little subsequent hand finishing. In 5-axis machines, the co-ordinates are to be interpolated depending upon the tolerance (deviation from the theoretical surface) to be maintained in producing the surface.



**Fig. 12.28. 5-Axis Machining**

#### v. Canned cycles

A canned cycle is a combination of machine movements that perform machining operations like drilling, milling, boring and tapping. For example, a drilling cycle consists of the following movements of the tool:

- Fast approach to workpiece
- Drill at feed rate
- Rapid return to initial position or to rapid level.

Ordinarily 3 blocks are required to program this drilling operation. Use of a canned cycle reduces this to one block. Once a canned cycle has been called, the system will execute the canned cycle at every subsequent table positioning. Therefore it is very important to call off (cancel) the canned cycle. The code G80 cancels all canned cycles.

Canned cycle for drilling is G81. This cycle (G81) is shown in Fig. 12.29. Figure 12.30 also shows a few other typical canned cycles used in machining centres.

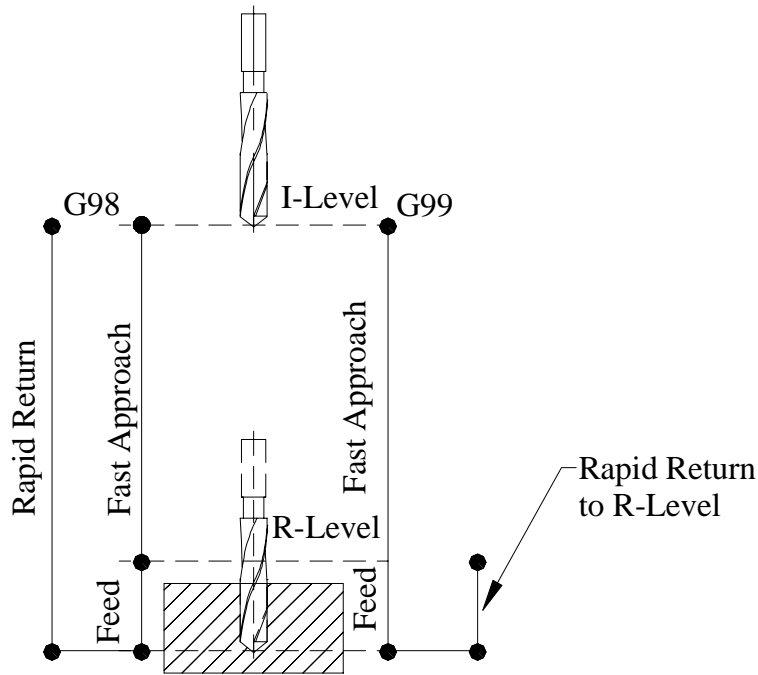
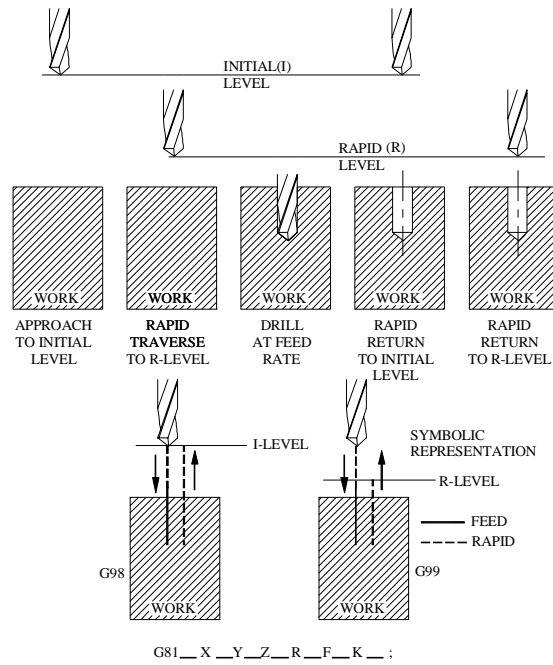


Fig. 12.29 Drilling Cycle

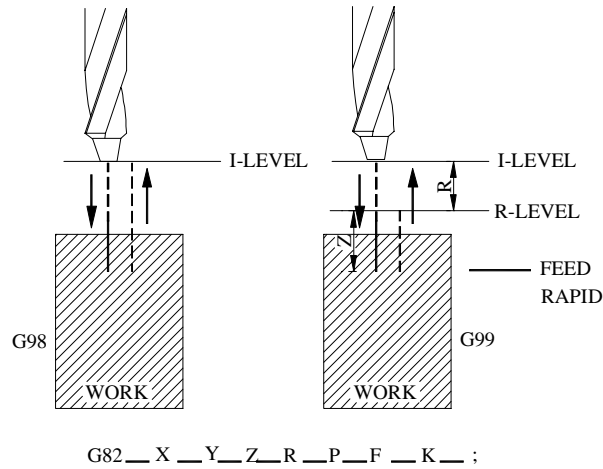
In CNC lathes several multiple, repetitive turning cycles like longitudinal turning cycle (G71), face turning cycles (G72), threading cycles (G76), peck drilling cycle (G83), contour parallel turning cycle (G73) are available. The use of canned cycles reduces programming effort. This also saves the length of program, thus saving space required to store the program.

The following points should be borne in mind while using canned cycles:

- i. Canned cycle is performed every time the table is positioned along X- and Y- axes.
- ii. Machining operation (drilling, tapping, boring etc) is performed from rapid level to the programmed Z-level.
- iii. The tool is then retracted either in rapid traverse or at feed rate or manually depending on the canned cycle.
- iv. Before specifying the canned cycle, a miscellaneous function code (M03 ) should be used to rotate the spindle.
- v. When K is used to specify a number of repeats, the M code is performed for the first hole only.
- vi. When a tool offset (G43, G44 or G49) is specified in the canned cycle, the offset is applied at the time of positioning to R-level.



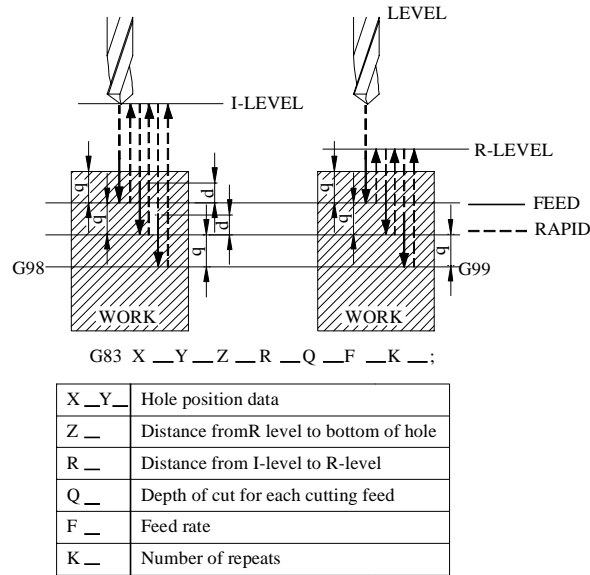
**Fig. 12.30 (a) G 81-Drilling/Spot Drilling Cycle**



X __ Y __	Hole position data
Z __	Distance from R to the bottom of hole
R __	Distance from I to R level
P __	Dwell time at the bottom of hole
F __	Feed rate
K __	Number of repeats

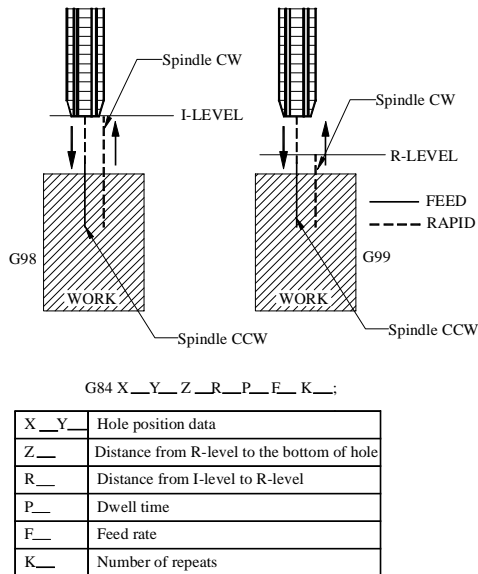
**Fig. 12.30 (b) G 82-Drilling/Counterboring Cycle**

G82 (Fig. 12.30 (b)) differs from G81 from in a small detail. There is a dwell at the end of machining which smoothens the end surface.



**Fig. 12.30 (c) G83- Peck Drilling Cycle**

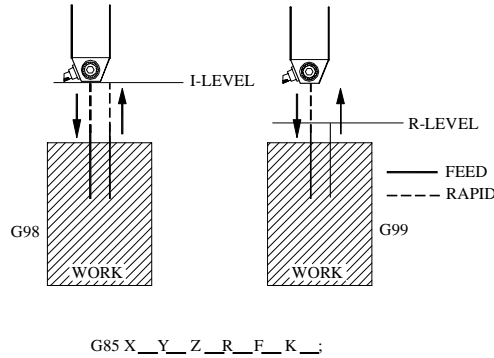
While drilling deep holes, a major problem encountered is the clogging of chips which may lead to drill breakage and poor surface finish. Retraction of the tool periodically



**Fig. 12.30 (d) G84-Tapping Cycle**



will avoid these problems. Q represents the depth of cut for each cutting feed. It must always be specified as an incremental value. In the second and subsequent cutting feeds, rapid traverse is performed unto a point where the last drilling ended and the cutting feed is performed again. The value of d is specified in machine parameter. For Fanuc 0 M this parameter is No.532.

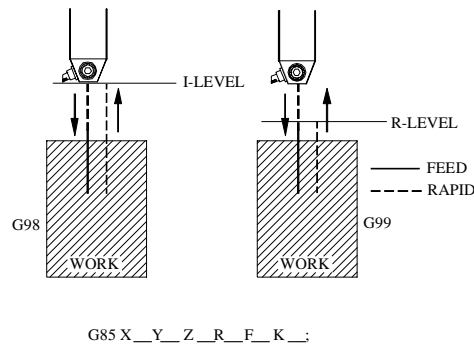


X__Y__	Hole position data
Z__	Distance from R-level to the bottom of the bore
R__	Distance from I-level to R-level
F__	Feed rate
K__	Number of repeats

Note: Tool is retracted at cutting feed upto R level

**Fig. 12.30 (e) G85-Boring Cycle with Return at Cutting Feed Rate**

The important feature of G85 is that the return from Z is performed at cutting feed rate.

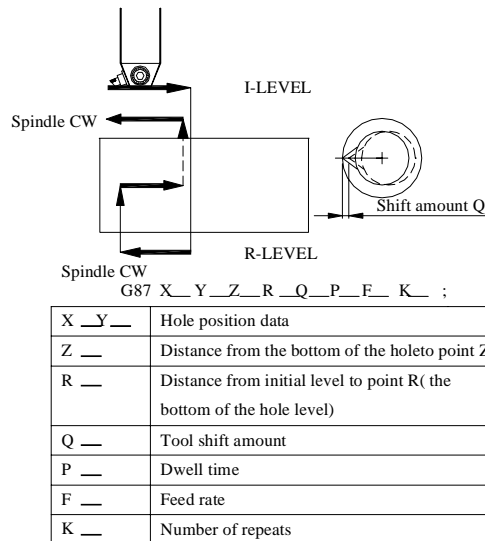


X__Y__	Hole position data
Z__	Distance from R-level to the bottom of the bore
R__	Distance from I-level to R-level
F__	Feed rate
K__	Number of repeats

Note: Tool is retracted at rapid traverse.

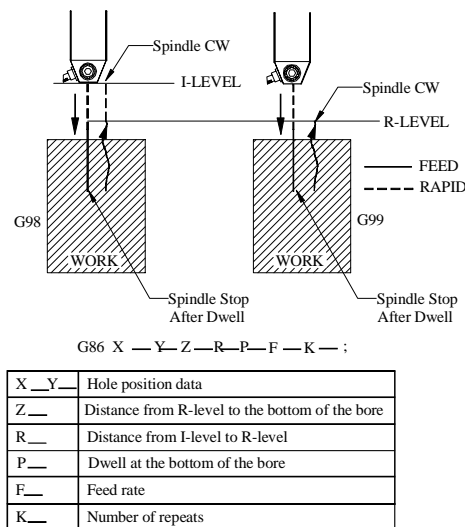
**Fig. 12.30 (f) G 86-Boring Cycle with Rapid Return**

In the canned cycle G86 the return from Z level is in rapid travers (Fig. 12.30 (f)).



**Fig. 12.30 (g) G 87-Boring Cycle for Back Boring**

G87 is used for back boring operations. After positioning along X-and Y-axes, the spindle is stopped at a fixed rotation position. The tool is then moved in the direction opposite to the tool tip. Positioning is then done to R-level. It may be noted that R-level is below the hole (Fig. 12.30 (g)).

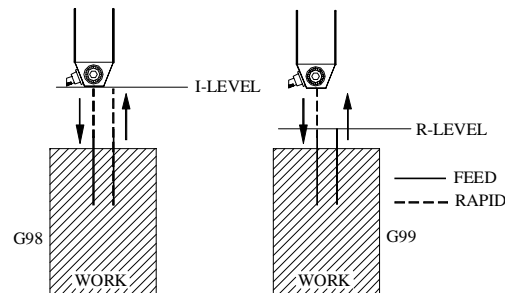


Note: Tool is manually retracted either to I or R level.

**Fig. 12.30 (h) G 88-Boring Operation with Manual Return to R Level**

Tool is then shifted in the direction of the tool tip and the spindle is rotated clockwise. Boring is performed in the positive direction along the Z-axis until the Z-level is reached. At this point the spindle is stopped in the fixed rotation position and the tool is shifted in the direction opposite to the tool tip. The boring tool is then returned to the initial position. The tool is then shifted in the direction of the tool tip and the spindle is rotated clockwise to proceed to the next block operation.

In this case the tool is retracted manually up to R level.



G89 X \_\_\_ Y \_\_\_ Z \_\_\_ R \_\_\_ P \_\_\_ F \_\_\_ K \_\_\_ ;

X ___ Y ___	Hole position data
Z ___	Distance from R-level to the bottom of the bore
R ___	Distance from I-level to R-level
P ___	Dwell time at the bottom of the bore
F ___	Feed rate
K ___	Number of repeats

A dwell is performed at the bottom of the hole.

Note: Tool is retracted at cutting feed upto R level

**Fig. 12.30 (i) G 89 Boring Cycle with Dwell**

The difference between this canned cycle and G 85 is that there is a dwell at the bottom which helps in finishing the end surface of the bore better.

Figures 12.30 (h) and 12.30 (i) show boring with manual return (G88) and boring cycle with dwell (G89)

#### vi. Tool offset/Tool compensation:

The NC program is written assuming that the tool traces the path (tool path) required to produce the part. The length of traverse of the slide should take into account the length of the tool. The longer the length of the tool is, the shorter will be the travel of the slide and vice versa. The CNC system therefore should calculate the displacement of the slides considering the tool length. The length of tool is measured beforehand and input into the appropriate registers of the system. This is called tool length offset.

These are manually input into the memory locations corresponding to each tool position. Whenever a tool is changed, it is necessary to measure the new tool length and

input it into the memory of the NC machine. Tool length offset is usually measured using a tool pre-setter which can be mechanical, optical or electronic. Probes are also fitted on the machine to determine and input the tool offset automatically.

In the case of machining centres the path of the slide has to be altered to take also the radius of the tool into account. This is called cutter radius compensation.

**Typical tool offset functions in a machining centre are:**

- G 45 - extension of axis travel by the amount stored in the offset data memory
- G 46 - Reduction by the amount stored in the offset data memory
- G 47 - Double extension
- G 48 - Double reduction

**Example:** G00 G45 Z-150.0 H04;

**H04** is the offset stored in number "04" of offset data memory.

Very often it is necessary to alter slide position in very small increments due to such factors like tool tip wear or wear of end mills etc. This is done through tool offset input.

In flexible manufacturing systems and other unmanned manufacturing situations, tool offset is automatically measured using suitable devices.

**vii. Tool nose radius compensation**

In profile turning, or pocketing, accuracy of the workpiece is affected by the tool nose radius of the tool. By incorporating a tool nose radius compensation call through an appropriate G - function, it is possible to compensate the effect of tool nose radius.

G41 Tool nose radius compensation, left

G42 Tool nose radius compensation, right

G40 Tool nose radius compensation cancel

**viii. Datum points**

Programming is done with reference to the fixed points (origin of co-ordinate system of the machine) or the datum points defined by the programmer. In the latter case, the datum points can be conveniently selected to reduce computations involved in converting machining locations into X, Y, Z co-ordinates. Up to six work co-ordinate systems can be selected in many machines. These are usually stored in the appropriate registers in the memory of the control system and recalled through the NC program. In many systems G54, G55, G56, G57, G58 and G59 are reserved for specifying coordinate systems.

## 12.11 PROGRAMMING OF CNC MACHINE TOOLS

CNC programming is a term that refers to the methods for generating the instructions that drive the CNC machine tool. For two dimensional components with little geometric complexity, CNC instructions can be written manually. However, as the geometrical

complexity increases more sophisticated techniques are required, particularly for 3-axis, 4-axis and 5-axis CNC machining.

There are three distinct techniques adopted for creating CNC programs:

- i. Manual CNC Programming
- ii. Programming using CAM software (CAD/CAM based programming systems)

Manual programming is recommended for simple workpieces which require only a few blocks of program. Programming of complex workpieces requires the help of a CAM software. CAD/CAM based systems have become popular recently and are now being widely adopted. Detailed description of these techniques is given in the following section.

### 12.11.1 MANUAL PART PROGRAMMING

This technique is widely used for workpieces of relatively simple geometry. The steps in manual programming are:

- i. Careful study of component drawing- materials, tolerances, surface finish etc
- ii. Select the raw material or blank if not specified.
- iii. Select the number of set ups necessary and the machine/s on which the part is machined.
- iv. Deciding the workpiece datum for each set up.
- v. Designing the fixtures or holding of the job.
- vi. Deciding the process and sequence of processes to achieve the desired accuracy and tolerances
- vii. Selecting the tools and cutting parameters.
- viii. Writing the program
- ix. Input the program and dry run; correct mistakes if any.
- x. Produce the first part and inspect.
- xi. Correct the program if necessary and progress to lot production.
- xii. Create documentation for future reference.
- xiii. Archive the program and documentation.

It was mentioned earlier that an NC program will consist of a number of lines called blocks. Each block will consist of a number of words. Each word will have two components: a word address and a numeric code representing information. The common word addresses are:

N - G - X - Y - Z - A - B - C - F - S - T - M

where

- N = sequence number of instructions  
 G = preparatory function  
 XYZABC = co-ordinate and angular data

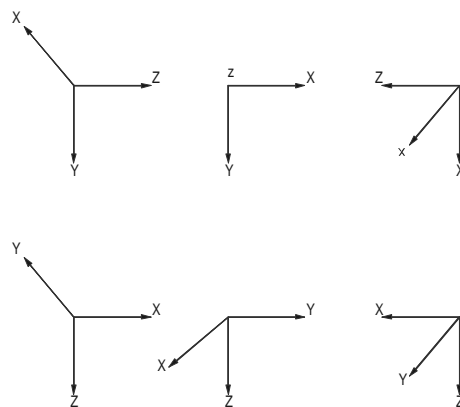
- F = feed  
 S = spindle speed  
 T = tool code  
 M = miscellaneous function

The program is directly input into the machine's memory through the following methods:

- i. Manual data input through the keyboard of the NC console.
- ii. A floppy disc and disc drive or magnetic tape.
- iii. DNC mode - directly from the computer used for programming or storage of program to the memory of the CNC machine.
- iv. The program can be transferred to the machine through a LAN or through Internet.

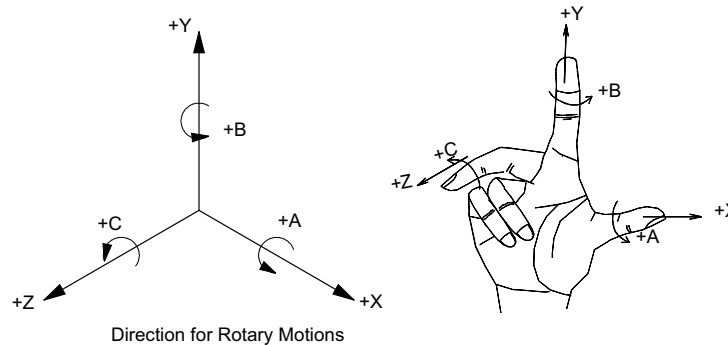
Today, another form of programming built in the CNC control itself is gaining acceptance. Using CNC programming software, the programmer can generate a set of instructions at the machine control itself. Using basic tool motion commands combined with canned cycles and custom or user defined macros the programmer can enter component geometry information on the front panel CRT, provide supplementary information about tool path and cause the CNC program to be produced automatically within the machine tool control.

### 12.11.2 NOMENCLATURE OF THE CNC MACHINES AXES



**Fig. 12.31 Co-ordinate System**

The co-ordinate system for designating the axes is the conventional right hand co-ordinate system. Some possible dispositions of these co-ordinates are shown in the Fig 12.31. One could use his right hand (as shown in Fig. 12.32) to get these alternative relative positions of the same right hand co-ordinate system.



**Fig. 12.32 Right Hand Co-ordinate Systems**

### 12.11.3 DESIGNATING THE MOTIONS

- i. **Location:** First of all, Z-motion shall be designated. This shall be followed by X and Y motions respectively. Z-axis motion is either along the spindle axis or parallel to the spindle axis.
- ii. **Direction:** For NC machines the positive (+) Z-motion increases the clearance between the work surface and the tool holder.
- iii. **When there are several spindles and slides:** In such cases, one of the spindles, preferably perpendicular to the work holding surface may be chosen as the principal spindle. The primary Z-motion is then related to the primary spindle. The tool motion of other spindle quills or other slides, which are termed as secondary and tertiary motions, may be designated as U, V, W and P, Q, R respectively.

#### **Rotary Motions:**

A, B and C defines the primary rotary motions.

- i. **Location:** These motions are located about the axis parallel to X, Y and Z respectively. If in addition to the above mentioned primary rotary motions, there exist secondary rotary motions, whether parallel or not to A, B and C those should be designated as D or E.
- ii. **Direction:** Positive (+) A, B and C are in the directions which advance a right hand screw in the positive (+) X, Y and Z directions respectively.

Programming of all CNC machine tools are done more or less on similar lines though there are several variations due to the type of machining involved.

The programming aspects of machining centres are discussed in detail below :

### 12.11.4 PROGRAMMING ASPECTS OF MACHINING CENTRES

A machining centre may be either 3 or 4 or 5 axis machine. A 3-axis machine may have simultaneous interpolation capability either in two or three axes. A machine usually will

have at least two pallets so that setting up of the workpiece can be carried out on one pallet while the workpiece on the other pallet is machined. The spindle size is designated by its taper (ISO 40, ISO 50, BT40 etc.). A distinguishing feature of the machining centre is the tool magazine which can hold several tools (32, 40, 80, 120 etc). Normally a tool is identified by the pocket in which it is inserted. The pockets are numbered consecutively. There will be an automatic tool changer (ATC) which transfers the tool between ATC and the spindle. While one operation is going on, ATC is ready with the tool for the next operation. Therefore, while programming, the tool required for the next operation is called at the start of an operation. Typically the tool changing time varies between 4 to 7 seconds. It may be as low as 0.5 sec in the case of high speed machines.

The datum point or surface for programming can be selected conveniently. There are a number of possibilities. Similarly a number of workpiece reference points can also be selected, and used in a program. These are entered in the memory of the system separately.

A machining centre with 3 axis control may also have a rotary table (B axis). If this is under CNC control it gives a fourth axis to the machine. In some machines, only discrete indexing may be available. This table can be indexed in steps of 5 degrees so that machining on several faces can be carried out in a single set up.

Programming requires knowledge of the G-codes and M-codes.

Table 12.11 and 12.12 give the G and M codes available in a typical CNC system.

**Table 12.11 Preparatory Functions**  
(G Functions) - FANUC 10

Group	G Code	Initial State	Description
01	G00		Positioning (Rapid feed)
	G01		Linear Interpolation
	G02	G01	Circular Interpolation/helical CW
	G03		Circular Interpolation/helical CCW
	G02.1		Circular threading CW
	G03.1		Circular threading, CCW
	G02.2		Involute interpolation, CW
	G03.2		Involute interpolation, CCW
	G02.3		Exponential function interpolation, CW
	G03.3		Exponential function interpolation, CCW
00	G04		Dwell
	G05.1		Multi-buffer
01	G06.1		Spline interpolation
00	G07.1		Cylindrical interpolation
	G09		Exact stop check
	G10		Setting offset amount and work zero offset amount
	G10.1		PMC data setting

Contd....



<b>Group</b>	<b>G Code</b>	<b>Initial State</b>	<b>Description</b>
	G10.3		High speed machining registration start
	G10.6		Tool retract data escape
	G11		Data setting mode cancel
	G11.3		High speed machining registration end
25	G12.1		Polar co-ordinate interpolation
	G13.1		Polar co-ordinate interpolation cancel model
17	G15		Polar co-ordinate command cancel
	G16		Polar co-ordinates command
02	G17		Selection of XY plane
	G18	G17	Selection of ZX plane
	G19		Selection of YZ Plane
06	G20	As selected	Inch input
	G21	before power turning off	Metric Input
04	G22		Stored stroke limit function on
	G23	G22	Stored stroke limit function off
24	G25		Spindle speed fluctuation detection off
	G26		Spindle speed fluctuation detection on
00	G27		Zero return check
	G28		Return to zero
	G29		Return from zero
	G30		Return to second zero
	G30.1		Floating zero return
	G31		Skip function
	G31.1		Multi-step skip function
	G31.2		Multi-step skip function 2
	G31.3		Multi-step skip function 3
01	G33		Thread cutting
00	G37		Automatic tool length measurement
07	G40		Cutter radius compensation cancel / 3-D tool offset cancel
	G41	G40	Cutter radius compensation, left / 3-D tool offset
	G42		Cutter radius compensation, right
19	G40.1		Normal direction control cancel
	G41.1		Normal direction control left on
	G42.1		Normal direction control right on
08	G43		Tool length compensation, plus
	G44	G49	Tool length compensation, minus

Contd....

<b>Group</b>	<b>G Code</b>	<b>Initial State</b>	<b>Description</b>
00	G49		Tool length compensation cancel
	G45		Tool offset extension
	G46		Tool offset reduction
	G47		Tool offset, double extension
	G48		Tool offset, double reduction
11	G50		Scaling cancel
	G51		Scaling
12	G54		Selection of work co-ordinate system 1
	G54.1		Additional work co-ordinate system
	G55		Additional work co-ordinate system 2
	G56	G54	Additional work co-ordinate system 3
	G57		Additional work co-ordinate system 4
	G58		Additional work co-ordinate system 5
00	G59		Additional work co-ordinate system 6
	G60		Single direction positioning
15	G61		Exact stop check mode
	G62		Automatic corner override mode
	G63		Tapping mode
	G64	G64	Continuous cutting mode
00	G65		Call of user macro
	G65.3		Call of high speed machining program
12	G66		Modal call of user macro
12	G66.1		Macro modal call B
16	G67	G67	Modal call of user macro, cancel
	G68		Co-ordinate system rotation
	G69		Co-ordinate system rotation cancel
	G71		Metric Mode
00	G72.1		Rotation copy
	G72.2		Parallel copy
09	G73		Peck drilling cycle
	G74		Reverse tapping cycle
	G76		Fine boring cycle
	G80		Fixed cycle, cancel
	G81		Drilling cycle, spot drilling
	G82		Drilling cycle, counter
	G83	G80	Peck drilling cycle
	G84		Tapping cycle
	G84.2		Rigid tapping cycle
G85		Boring cycle	

Contd....

	G86		Boring cycle
	G87		Back boring cycle
	G88		Boring cycle
	G89		Boring cycle
03	G90	G91	Absolute command
	G91		Incremental command
00	G92		Setting co-ordinates
	G92.1		Work co-ordinate system preset
05	G93		Inverse time feed
05	G94	G94	Feed rate, mm/min mode
	G95		Feed rate, mm/rev. mode
10	G98	G98	Initial level return in fixed cycle mode
	G99		R level return in fixed cycle mode

**Table 12.12 M-Codes in a CNC System**

	M00	Program stop
	M01	Optional stop
	M02	End of program
	M03	Spindle CW
	M04	Spindle CCW
	M05	Spindle stop
	M06	Tool change
	M07	Tap Oil on
	M08	Coolant on
	M09	Coolant/Tap Oil off
	M10	B-axis clamp
	M11	B-axis unclamp
	M12	Hydraulic power rotary table on
	M14	Oil hole drill coolant on
	M16	Heavy tool change
	M17	Tap cycle confirmation
	M18	Tap cycle cancel
	M19	Spindle orientation
	M20	Coolant nozzle up
	M21	Coolant nozzle middle
	M22	Coolant nozzle down
	M23	Detection of contact in -X
	M24	Detection of contact in +X
	M25	Detection of contact in -Y

*Contd....*

M26	Detection of contact in +Y
M27	Tool breakage detection
M28	Automatic gap elimination
M29	M27 & M28 together
M30	End of program and rewind
M50	Air blow on
M52	Tool length offset measurement
M53	Tool length Offset execution
M54	Tool length Offset cancel
M57	Measurement along Z axis
M58	Execution along Z axis
M59	Cancel along Z axis
M60	Measurement along +X axis
M61	Measurement along -X axis
M62	Execution along X axis
M63	Cancel along X axis
M64	Measurement along +Y axis
M65	Measurement along -Y axis
M66	Executing along Y axis
M67	Cancel along Y axis
M70	Return to zero rotary table position
M73	Y Axis mirror image off
M74	Y Axis mirror image on
M75	X Axis mirror image off
M76	X Axis mirror image on
M80	Rotary table CW rotation
M81	Rotary table CCW rotation
M82	Step mode tool removal
M83	Step mode tool change cycle
M84	Step mode tool jog operation
M88	Splash guard open
M89	Splash guard close
M90	Pallet change
M92	Pallet unclamp
M96	Pallet loading and advance
M97	Pallet loading retract
M98	Call of sub program
M99	End of sub program

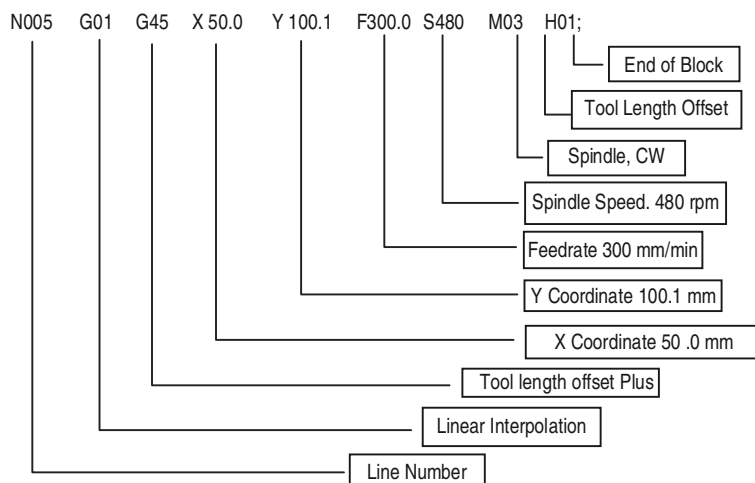
### 12.11.3 PROGRAMMING CODES

Programs are written using the standard word addresses given below :

- N Sequence number (1 to 9999)
- G Preparatory function: Up to 4 G functions in a block are permitted. Some systems use G codes in three digits too.
- X
- Y Dimension mode in each axis, up to 3 decimal place
- Z
- I
- J Arc centre offset in X, Y, Z axis + or - Axis direction
- K
- P, Q Word address codes, meaning depending on G function
- B Rotation axis about Y axis
- F Feed rate mm/min; eg.F300.0
- S Spindle speed; e.g. S630
- T Tool function (TXX to TYY), say depending on number of tools in the magazine
- M Miscellaneous function
- H Offset number
- E Dwell function
- D Cutter radius offset
- L No. of repetitions of fixed cycle and sub program

#### **Example of a program block:**

A typical block of program may be written as:



#### 12.11.4 DATUM SETTING

Before preparing a program, the origin or the program (machining) origin must be determined. This datum is the reference point for programming and cutting.

The selection of machining origin depends on:

- Workpiece shape
- Use/non-use of fixtures
- Convenience in programming
- Workpiece preparation

Some examples of locating datum on a horizontal machining centre are shown in Fig. 12.33.

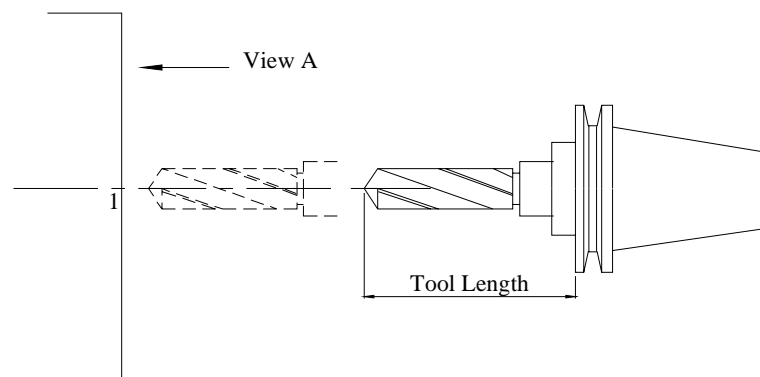


Fig. 12.33 (a) Locating Datum on a Horizontal Machining Centre

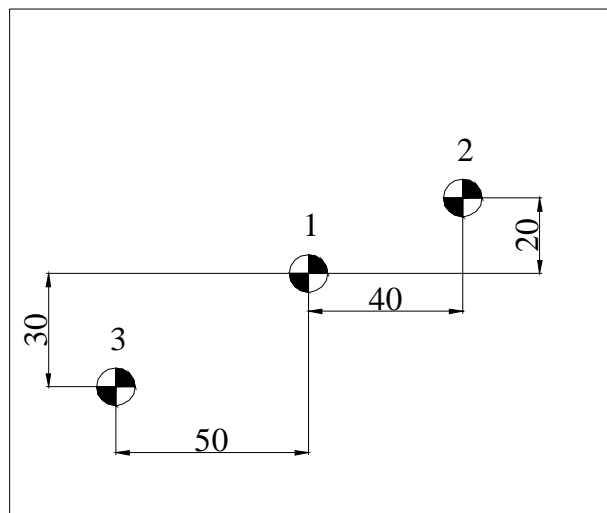


Fig. 12.33 (b) Locating Datum on a Horizontal Machining Centre

Figure 12.33 is an example of how multiple work coordinate systems can be set by G92 command.

Position 1	G92 X0Y0	G92 Z0
Position 2	G92 X-40Y-20	G92 Z-120
Position 3	G92 X50Y30	

In Fig 12.33 setting the values of X=0, Y=0 sets the program datum at the preset tool position as 0.0. The Z-axis datum is fixed at present position with z = 0. The work coordinate system can be redefined as shown for positions 2 and 3.

In addition there are six work co-ordinate datum setting code (G54 to G59). These can be called in the program. This facility is very useful for programming complex box shaped components.

## 12.12 HINTS FOR PROGRAMMING

The following procedure is recommended to prepare a NC program.

### (i) Study of specification of machine and codes in the control system

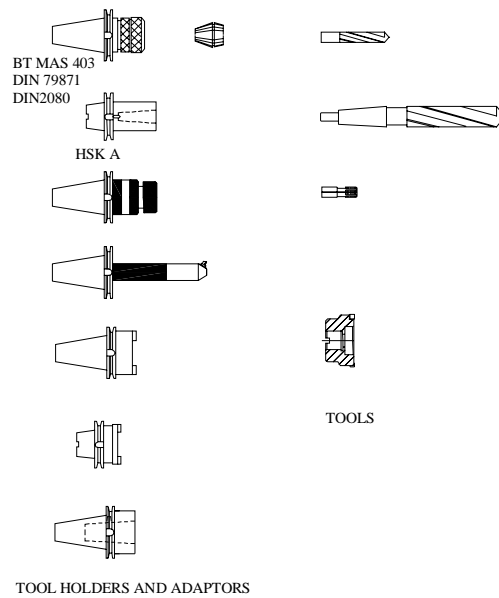
Check the following item before you start programming:

- Travel and direction of numerically controlled axis
- Location of machine zero point
- System of ATC
- G and M codes available on the selected machine and control system
- Shape and dimensions of the fixture to be used
- Location of the fixture on the machine table.

### (ii) Tooling system

NC program requires detailed data on tools, tool holders and cutting conditions for a given tool-workpiece combination. Figure 12.34 shows typical tools used in a machining centre. The tools can be integral with the tool holder or can be directly attached to the tool holder. Sometimes intermediate adapters are also used. Tools commonly used are drills, end mills, face mills, taps, boring bars etc. There are several special tools also available. There is a pull stud at the opposite end of the tool holder which is used to clamp the tool in the machine. The clamping is done usually hydraulically.

Suitable fixturing is required to hold the workpiece on the table of the machine. Particular care has to be taken for the design of the fixtures in unmanned manufacture. Modular fixtures are recommended for economy and reduction in lead time.



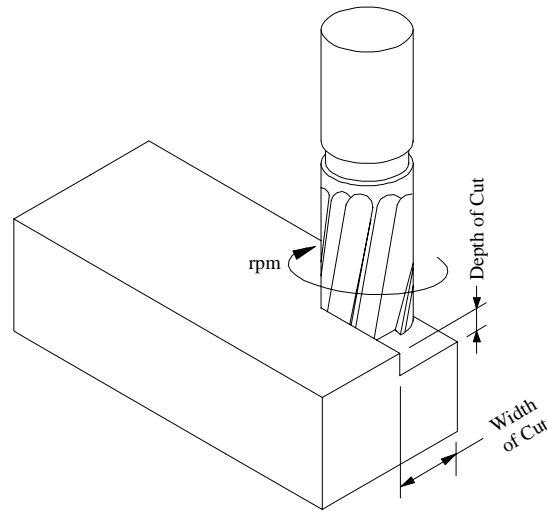
**Fig. 12.34 Tools Used in a Machining Centre**

**(a) Cutting conditions**

Cutting conditions should be carefully selected during program preparation since these conditions greatly influence cutting efficiency, production rate, cost and accuracy. In the case of a machining centre the following four cutting conditions are required (See Fig. 12.35).

- (i) **Spindle speed (rpm):** This is directly designated immediately after the letter S. For example, if a spindle speed of 500 rpm it is designated as S500. Spindle speeds are obtained from recommended cutting speeds.
- (ii) **Feed rate for cutting (mm/min):** Feed rate is specified after the letter F. e.g. For a feed rate of 250 mm/min the program specifies F250. Feed rate is the product of feed/tooth, number of teeth of cutter and rpm of cutter. **In the case of tapping the feed rate is rpm x pitch of the thread.**
- (iii) **Depth of cut:** The depth of cut is determined by the position of the tool in the Z-direction.
- (iv) **Width of cut:** The width of cut is determined by the positions of the table along X and Y-axes.





**Fig. 12.35 Cutting Conditions**

The cutting conditions are selected either from the handbooks or from the cutting data supplied by the manufacturers of cutting tools. The rpm of the spindle is calculated from the recommended cutting speed. From Table 12.13 the cutting speed for machining carbon steel with a solid carbide cutter at a depth of cut of 4 mm, feed of 0.25 mm/tooth and tool life of 30 minutes is 183 m/min (V). If the diameter of the end mill is 18 mm (d), the spindle rpm (N) will be:

$$\begin{aligned} N &= 1000 V / (\pi d) \\ &= 3237 \text{ say } 3240 \text{ rpm.} \end{aligned}$$

Tables 12.13 and 12.14 give the recommended cutting data for carbon steel and cast iron.

**Table 12.13 Typical Cutting Data for Carbon Steels**

		Feed, mm/tooth							
		0.05	0.1	0.15	0.2	0.25	0.3	0.35	0.4
		Tool life, minutes							
		45	40	35	32	30	25	20	—
a*, mm	Cutting Speed, m/min								
2	220	214	208	202	196	190	185	—	—
4	205	200	194	188	183	178	173	—	—
6	190	185	179	174	169	165	160	—	—
8	177	172	167	162	158	153	—	—	—
10	165	160	155	150	145	—	—	—	—

\* Depth of Cut  
For cutter diameters between 12 and 25 the maximum depth of cut is 8 mm.

**Table 12.14 Typical Cutting Data for Cast Iron**

		Feed, mm/tooth							
		0.05	0.1	0.15	0.2	0.25	0.3	0.35	0.4
		Tool life, minutes							
		55	45	40	35	35	30	25	20
a', mm	Cutting Speed, m/min								
2	270	246	235	225	215	205	195	187	
4	205	228	218	208	199	190	181	173	
6	230	210	201	192	183	175	167	160	
8	213	195	186	178	170	162	—	—	
10	202	185	177	169	162	155	—	—	

\* Depth of Cut

For cutter diameters between 12 and 25 the maximum depth of cut is 8 mm.

### (b) Calculating spindle speed & feedrate

Spindle speeds (N) and feedrate (S) may be calculated based on the cutting speed (V, m/min) and feed (F, mm/rev) according to the equation given below:

$$N \text{ (rpm)} = 1000 V / (\pi d)$$

and  $S = F \times N$ ; Where, d = Diameter of the cutter, mm

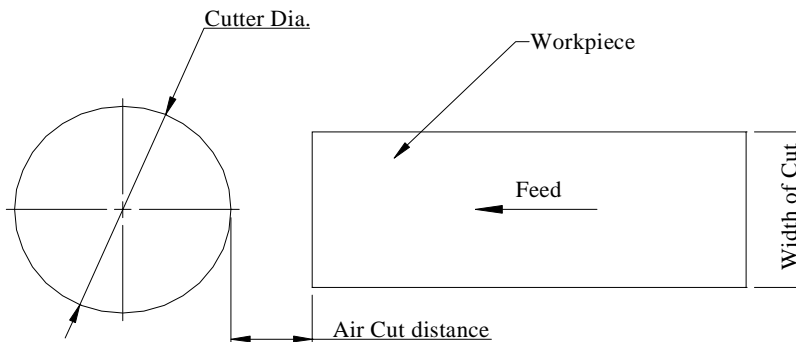
#### **Example:**

Material : Cast iron  
 Type of cut : Milling  
 Material of tool : Carbide  
 Cutter diameter : 63 mm  
 Feed : 0.2 mm/blade  
 No. of teeth : 6  
 Depth of cut : 4 mm  
 Cutting speed  
 (from Table 12.14) : 208 m/min

$$N = 1000 \times 208 / (\pi \times 63) = \text{(say) } 1050 \text{ rpm}$$

### (c) Calculating length of axis move

Since direction of axis movement greatly affects machining time, such dimensions should be determined after studying the characteristics of the cutter to be used. It is necessary to change the axis movement dimensions according to the conditions of tool setting dimensions, fixture details and finished condition of the workpiece in the preceding machining steps.



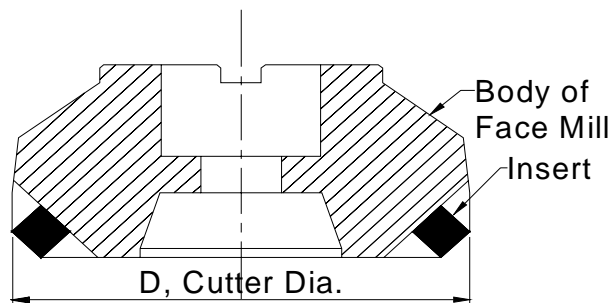
**Fig. 12.36 Air Cut Distance**

Some of the important points to be considered are given below:

### Milling

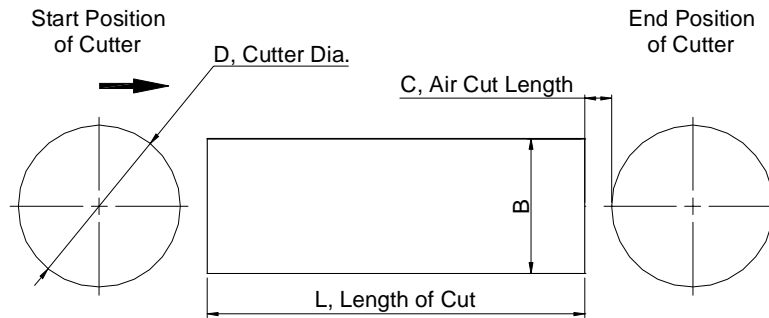
- (i) On milling, air cut stroke along Z axis is zero. Therefore the cutter may be fed to cutting start point at a rapid feedrate. Care should be taken so that the cutter may not collide with the workpiece when it is fed along Z-axis direction in rapid feedrate after positioning along X and Y axis has been made.
- (ii) Air cut stroke should be provided along X and Y axis direction (Fig. 12.36).

Face mill cutter is generally sized in inch system. However, it should be noted that nominal size of the cutter does not indicate the maximum diameter of the cutter (See Fig. 12.37). Therefore too small air cut stroke might cause unexpected collision of the cutter with the workpiece.



**Fig. 12.37 Size of Face Milling Cutter**

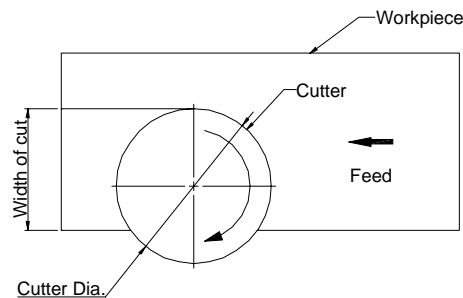
- (iii) Feed stroke for milling: Figure 12.38 shows a workpiece of width B and length, L being milled using a face milling cutter, which is represented as a circle. Stroke in which axis is to be fed at a cutting feedrate is the sum of cutter diameter, air cut amount and dimension of the workpiece whose surface is required to be milled. Feed stroke in milling is calculated based on the centre of the milling cutter.



**Fig. 12.38 Length of Stroke**

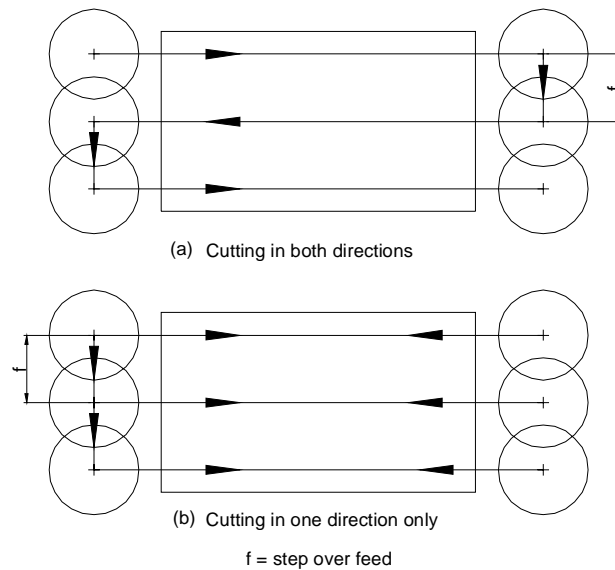
$$\text{Length of stroke} = L + 2C + D$$

- (iv) **Cutting width for milling:** If the width of cut in face milling is equal to the diameter of the cutter, there is the likelihood of vibration or chatter which is detrimental to the cutter. Hence the width of cut with a milling cutter is usually 70 to 75 percent of the diameter of the cutter used. In some cases, milling may have to be carried beyond this limit. In such a case, cutting conditions should be suitably reduced. If the width of the surface to be milled is more than the diameter of the cutter, the milling is to be carried out in more than one pass.



**Fig. 12.39 Width of Cut in Face Milling**

- (v) **Cutter Marks:** Face milling operation will leave cutter marks on the cut surface. The orientation of cutter marks depends on the direction of feed. Figs.12.40 (a) and (b) illustrate how the feed direction should be changed to get the desired orientation. In Fig. 40(a) after one pass, cutter is moved to the position corresponding to the next pass. The feed direction is opposite to that of the previous pass. Thus, feed direction changes in alternate passes. The cutter marks will be changing for every pass. In Fig. 40 (b) the cutter is returned to the starting position after each pass. In this case the feed direction is same for all passes. In this case the cutter mark will be the same for all passes. Another important point to be noted is that the milling cutter should be as short as possible to reduce vibrations.



**Fig. 12.40 Feed Direction and Orientation of Cutter Marks**

### Drilling

The dimension between the drill shoulder and the tip point should be taken into consideration in calculating in-feed dimensions. If not, the drilled hole will not be as deep as desired causing tapping tool to be broken. Figure 12.41 illustrates a drilling operation.

The dimension between the drill shoulder and the tip point is calculated as below (for standard twist drill) :

$$C = 1/3 \times D$$

### **Air cut stroke:**

Air cut stroke should be determined based on the condition of surface on which drilling is done.

For components with rough skin (as cast surface),  $A = 5$  mm minimum.

For machined surface,  $A = 2$  to  $3$  mm

For blind holes like the one shown in Fig.12.41

$$L1 = L + A + C$$

In case of through hole the stroke length in drilling may be determined in the same manner shown in Fig. 12.42.

$$L1 = A + L + C + 2$$

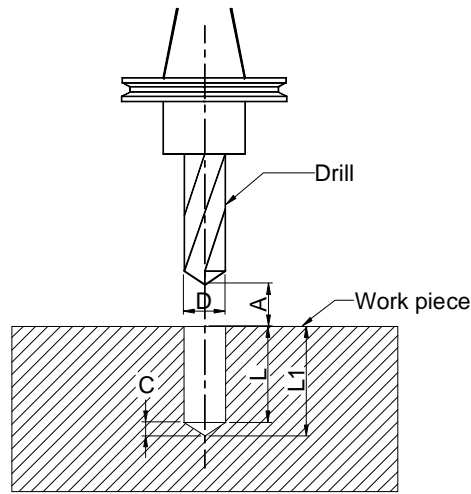


Fig. 12.41 Drilling

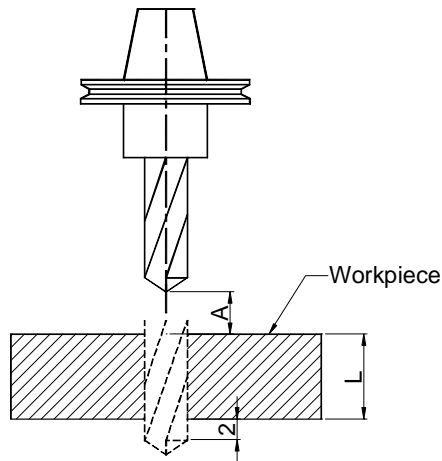


Fig. 12.42 Length of Stroke in Drilling

### Tapping

Great care should be taken while designating feed rate as well as in-feed stroke while tapping.

$$\text{Feed rate of tapping tool} = \text{Tap pitch} \times \text{Spindle speed}$$

In tapping operation, actual feed rate of the tap and the machine axis feed rate may not coincide. Since most machines employ direct four digit S code system, feed rate very close to actual tap feed rate may be commanded. However, it is still impossible to exactly match them. Therefore tap holder should be selected carefully taking the characteristics of the tap into consideration.

**The types of tap holders widely used are:**

- i. Combination type
- ii. Expansion type
- iii. Compression type

If expansion or combination type is used, programmed feed rate could be about 15% (differs from model to model) smaller or larger than actual tap feed rate.

Generally, combination type is used on machining centres. This type of holder allows the feed rate to be programmed to be equal to actual tap feed rate. Even in this case, however, the programmed feed rate may vary within about 3 to 4% smaller than actual feed rate.

Air cut stroke in tapping should be at least equal to two times air cut distance in drilling.

As indicated above, programmed feed rate and actual feed rate of a tap does not completely match. Therefore, if air cut stroke is small, the tap might be still engaged even after completion of tool retraction command. Machine axes will start positioning after retraction command is executed disregarding whether the tap is still engaged or not, causing the tap and tap holder to be damaged.

**End milling**

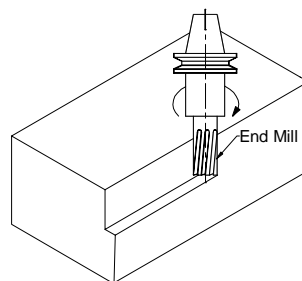
End mill is used in many applications. An example of milling a step is illustrated in Fig. 12.43. Requirements on end milling differ according to application. For cutting along Z axis, air cut stroke may be determined in the same manner as in drilling.

For cutting along X or Y axis, air cut stroke and axis movement stroke may be determined in the same manner as in milling. However air cut stroke in end milling is smaller than in milling.

**Boring**

Air cut stroke may be determined in the same manner as in drilling. Since close tolerance is required in boring operation, the boring tool most adequate to achieve the specified accuracy must be selected.

For a machine equipped with ATC, spindle taper and magazine socket taper must be cleaned periodically to maintain the intended accuracy. Concerning machining sequence, a proper canned cycle meeting the requirements of the hole to be bored, should be selected.



**Fig. 12.43 End Milling**

## Reaming

Although air cut stroke may be determined in the same manner as in drilling, in-feed stroke must be determined taking the chamfered tip of the reamer into consideration.

### 12.13 EXAMPLE OF PROGRAMMING A VERTICAL MACHINING CENTRE

Figure 12.44 shows the line diagram of a vertical machining centre. The table moves in X and Y directions and the up and down movement of the spindle gives the Z axis motion. According to the right hand thumb rule notation the table movements to the left (X) and away from the column (Y) are positive.

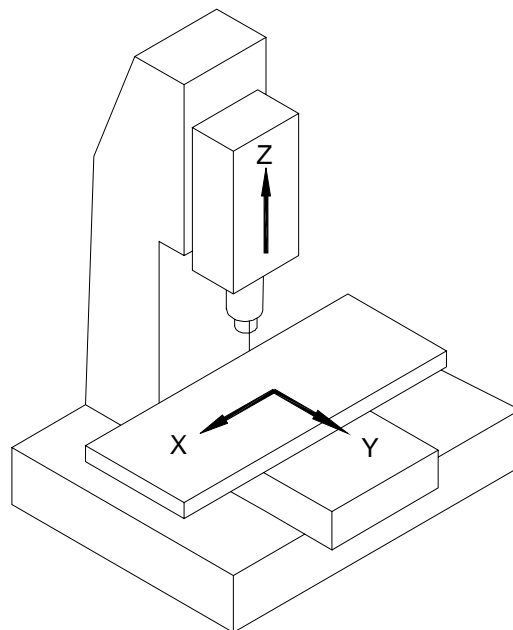
However, in programming practice, the tool is considered to move relative to the workpiece and hence the directions are redefined as:

Tool movement to the right + X

Tool movement towards the column + Y

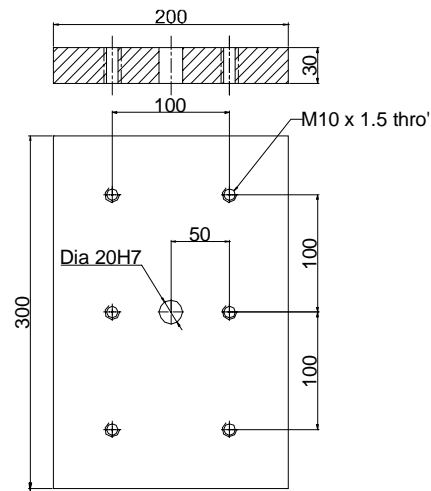
The following example illustrates the approach to programming a simple component in a vertical machining centre. The component is shown in Fig 12.45. The blank is of size  $300 \times 200 \times 50$  pre-machined. There are six M10  $\times$  1.5 tapped holes and a centre hole of  $\phi 20$  H7.

A systematic approach to programming involves the following steps:



**Fig. 12.44** Axes of a Vertical Machining Centre

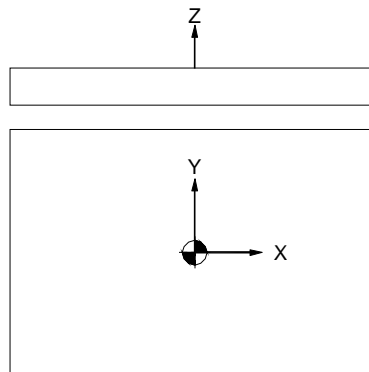




**Fig. 12.45 Drawing of the Component**

### 12.13.1 SETTING THE WORK PIECE ORIGIN

The program coordinates are conveniently selected with reference to a work piece datum or work piece origin. The work coordinate system can be selected to suit the datum used for dimensioning the work piece. In the present example the centre of the top surface is a suitable point to be selected as origin and the X- and Y- axes directions are shown in Fig. 12.46. The X and y axes are shown in the plan view and the Z- axis is shown in the elevation in the figure. The Z- axis is normal to the work surface and the positive direction means the movement of the tool away from the work surface.

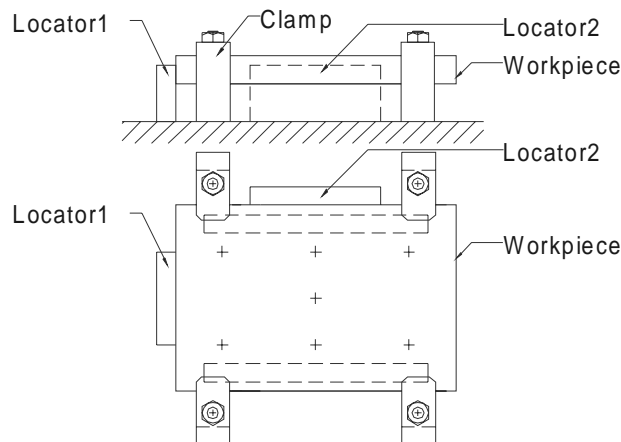


**Fig. 12.46 Setting the Work Piece Datum**

It may be noted that the axis directions indicated in Fig. 12.46 represent tool movements relative to the work piece. The X- and Y- axes movements are therefore opposite to those indicated in Fig. 12.44.

### 12.13.2 DESIGNING THE FIXTURE

The workpiece is to be properly located and clamped to ensure that all degrees of freedom of the workpiece are arrested. The fixture must be rigid enough to withstand the static and dynamic forces encountered in cutting. Foolproof loading is another important consideration. Modular fixtures are recommended in preference to custom-built fixtures. A detailed discussion about the modular fixtures have been included in this text . A simple fixture is shown in Fig. 12.47. wherein the component is located on two flat locators at the bottom and two locators at the sides. The work piece is clamped at the top without interference to the machining operations. It may be noted that standard components are used in the fixture design which will make the realization of the fixture faster. Thus the main aspects of fixture design like 3-2-1 location, adequate clamping and avoidance of interference with the tools while cutting have been taken care of. Fixture must be located on the table of the machine such that the defined work coordinate system should coincide with the centre of the work piece.



**Fig. 12.47 Fixture Design**

### 12.13.3 PROCESS DESIGN

The next logical step in the programming process is the process design. In this example there are two main machining operations to be performed viz. tapping six holes and producing a toleranced hole. The threaded holes can be realized in four operations or processes.

- i. Centre drilling
- ii. Core drilling (In the case of  $M10 \times 1.5$  in C.I the core diameter is 8.5 mm  
This data can be obtained from standard data books.
- iii. Chamfering the holes
- iv. Machine tapping  $M10 \times 1.5$

The hole  $\phi 20$  H7 being a precision hole requires the following processes:

- i. Centre drilling
- ii. Drill a pilot hole of  $\phi 18$
- iii. Drill a hole of  $\phi 19.5$  so that only a small allowance is left for the final boring or reaming operation. Leaving only a small allowance for the final finishing operation improves the accuracy of the hole.
- iv. Boring  $\phi 20$ H7. Boring is preferred to reaming as boring facilities better control of dimensions in batch manufacture.

In programming the machining centres a common-sense approach is to finish all operations using a tool in one go. This is because positioning of the table will take less time than tool changing. Therefore centre drilling at all the seven locations can be done as one process. Thus there are a total of 7 processes. They are listed below in Table 12.15.

**Table 12.15 Processes**

<i>Process</i>	<i>Tool</i>	<i>Operation</i>
1	Centre drill	Centre drilling
2	$\phi 8.5$ Drill	Drilling core holes for M10 tap
3	$\phi 18$ Drill	Pilot hole for $\phi 20$ hole
4	$\phi 19.5$ Drill	Semi-finishing $\phi 20$ hole
5	$\phi 25$ Chamfering tool	Countersinking the hole
6	M10 $\times$ 1.5 Tap	Tapping
7	$\phi 20$ H7 Boring	$\phi 20$ H7 hole boring

#### 12.13.4. SELECTION OF CUTTING CONDITIONS

Once the processes are selected the next step is to choose the cutting conditions. The factors influencing the cutting parameters are:

- Work material and its hardness
- tool material
- roughing or finishing feed, depth of cut.

Tables of cutting speeds and feeds are available from which one can make the appropriate selection of the cutting conditions. Spindle speeds and feed rates are coupled from these data and are then tabulated as shown in Table 12.16.

**Table 12.16 Process Sheet**

<i>Process</i>	<i>Tool Pocket No</i>	<i>Tool Details &amp; Cutting Speed (m/min)</i>	<i>Spindle speed rpm</i>	<i>Feed rate mm/min</i>	<i>Tool offset</i>
N1	1	4mm centre Drill, 25m/min	2000	100	1
N2	2	8.5 Drill, 25 m/min	936	187	2

Contd....

N3	3	18 Dril, 25m/min	442	88	3
N4	4	19.5 dril, 25/m min	408	82	4
N5	5	25 Chamfering tool, 20 m/min	254	51	5
N6	6	M10 x 1.5 Tap, 10 m/min	318	477	6
N7	7	20H7 Boring (Carbide Tipped 75 m/min	1194	119	7

**Note:**

- It is not necessary to name processes as N1, N2 etc. in the serial order. Similarly tool pocket numbers and offset numbers can be selected at the convenience of the programmer.
- In machining centres feed rate is specified instead of feed  
 $\text{Feed rate} = \text{Feed} \times \text{rpm}$   
 $\text{Feed rate} = \text{Feed per tooth of the cutter} \times \text{number of teeth} \times \text{rpm}$
- In threading feed is equal to pitch. Therefore feed rate for tapping is obtained by multiplying the pitch of the thread by the rpm of the tap.
- Tool length offset values corresponding to each tool are input in the memory of the CNC system in the appropriate registers.

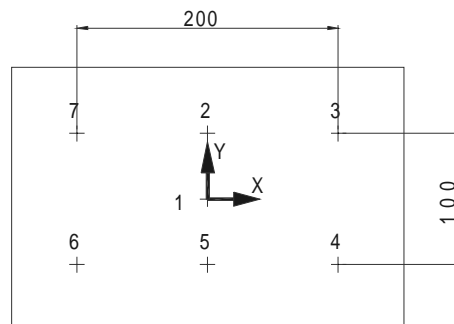
**12.13.5 PROGRAMME PREPARATION**

An inspection of the component shows that the table positioning movements are for many operations are repetitive in nature and hence these movements can be coded in a sub-programme.

**12.13.5.1 Sub-programme**

The sub-programme is written assuming that the spindle is positioned above the reference point (work piece datum) 1. The tool is then successively positioned at locations 2, 3, 4, 5, 6 and 7. Please refer to Fig. 12.47 and Fig. 12.48.

Like the main programme sub-programme is given a programme number.



**Fig. 12.48 Locations Visited in the Sub Program**

027 ;(Programme Number 27. This number is used to call the sub-programme in the main programme.)

X0.0 Y50.0 ;	(Position 2)
X100.0 ;	(Position 2)
Y-50.0 ;	
X0.0;	
X-100.0 ;	
Y50.0 ;	
M 99 ;	(Return to the main programme)

### 12.13.5.2 Main Programme

018 ;	(Programme number 18)
(Part-name)	
G0 G40 G80 ;	(Rapid traverse) (Cutter compensation cancel) (Canned cycle cancel)
G91 G28 X0 Y0 Z0 ;	(Incremental positioning) (XYZ zero return)
/T1 ;	(Call tool in Pocket #1 Centre Drill)
/M06	(Call tool change) (Tool #1 is now inserted in the spindle)

**Note :** Block delete switch (/) is used here as these blocks are used only during set up. These blocks with “/” sign are again provided at the end of the programme. Hence during repeated machining the block delete switch is kept in the **on** position and these lines preceding / symbol are ignored.

M1 ;	( An optional stop code is introduced so that the program will temporarily cease execution to facilitate inspection. The program will continue if the “ Start” button is pressed. Once the program is proven, the optional stop switch is shifted to “off” mode so that M1 code is ignored.)
------	--

#### **(Centre Drilling)**

N1 T2 ;	(Calling next tool i.e. 8.5 Drill)
G0 G90 G54 G43 X0 Y0 Z50.0 H1 S2000 M3 ;	(Select work co-ordinate system (G54) Rapid positioning above location 1 Tool length offset 1 active Spindle speed 2000 rpm Spindle rotation clockwise (M03))

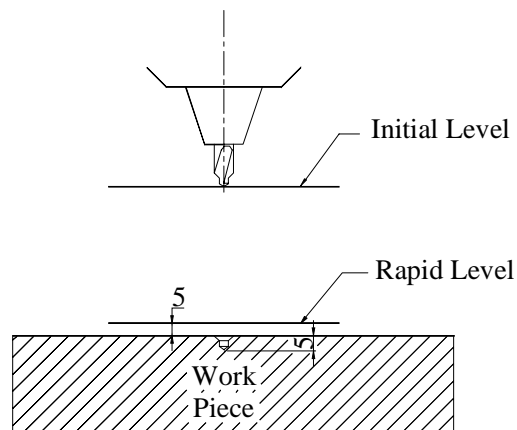
G98 G81 Z-8.0 R47.0 F100.0 (Canned cycle (Drilling) G81  
 Return to Initial position (G98)  
 Drilling depth = -5 mm  
 Rapid up to Z = 3 mm  
 Feed rate 100 mm / min)

M98 P27 ; (Calling sub programme #27- Centre drilling in 7 locations)

G80 G91 G28 Z0 ; (Fixed cycle cancel  
 Z axis zero return)

M6 ; (8.5 mm drill is now inserted in the spindle  
 The centre drill is returned to the tool magazine)

M1 ; Optional stop



**Fig. 12.49 Centre Drilling Cycle**

(8.5 Drill)

N2 T2 (Process #2, calling Tool #3)

G0 G90 G43 X0 Y0 Z50.0 H2 S936 M3;

G99 G81 Z-38.0 R47.0 F187 L0; (Rapid traverse to stop at Z=3 mm  
 Depth = 35 mm  
 Return to initial rapid level (G99)  
 No machining to be done at this  
 position (L0))

M98 P27 ;

G80 G91 G28 Z0 ; Returned to Z home position for  
 tool change

M 6 ;

M1 ;  
(18 DIA DRILL)  
N3 T4 ;  
G0 G90 G43 X0 Y0 Z50.0 H3 S442 M3 ;  
G81 Z41.0 R47.0 F88 ;  
M 98 P27 ;  
M6 ;  
M1 ;

(19.5 DRILL)  
N4 T5;  
G0 G90 G43 X0 Y0 Z50.0 H4 S408 M3 ;  
G81 Z -38.0 R47.0 F82 ;  
G80 G91 G28 Z0 ;  
M6 ;  
M1 ;

(CHAMFERING)  
N5 T6 ;  
G0 G90 G43 X0 Y0 Z50.0 H3 S442 M3 ;  
G81 Z-41.0 R47.0 F88 ;  
G80G91G28Z0;  
S500 H5 M3;  
G99G81 Z - 6.0 R47.0 F51 L0 ;  
M98 P27  
G80 G91 G28 Z0 ;  
M6 ;  
M1 ;

(M10 × 1.5 TAP)  
G0 G90 G43 X0 Y0 Z50.0 H6 S318 M3 ;  
G84 Z-38.0 R40.0 F477 L0;

**(Note:** Tapping cycle G84 involves rapid traverse, feed, reverse feed and return)

M98 P27 ;  
G80 G91 G28 Z0;  
M6 ;  
M1 ;  
(f20 H7 BORING)  
N7 T1 ;  
G0 G90 G43 X0 Y0 Z50.0 H7 S1194 M3;

**(Note:** Boring, being a critical operation is performed in two stages during initial trials. A distance of 5 mm is first machined and the operator can check whether the hole is within tolerance

limits. That is why the four succeeding lines of programme starts with block delete symbol. Once the setting of the boring bar is proven to be satisfactory the block delete switch can be thrown into the "ON" position thereby ignoring these lines during regular production run)

```

/G81 Z-5.0 R3.0 F119 ;
/G80 G91 G28 Z0 M5 ;
/M1 ;
/G0 G90 G43 X0 Y0 Z50.0 H7 M3 ;
/G81 Z-8.0 R47.0 F119 ;
/G80 G91 G28 Z0 M5 ;
/M1 ;
/G0 G90 G43 X0 Y0 Z50.0 H7 M3 ;
G76 Z-35.0 R47.0 P0.5 Q0.5 F119 ;      (P, Dwell 0.5 Sec,
                                          Q, Offset 0.5 mm)

```

**Note:** G76 is precision boring operation. At the end of the boring operation the tool is withdrawn along the radial direction at the orientated stop position of the spindle. There is a dwell of 0.5 sec and the boring bar is withdrawn.

```

G80 G91 G28 Z0 ;
M6 ;
M30 ;

```

**Note:** The readers are advised to compare the G and M codes used in this program with the G and M codes of the machines available with them as there may be differences in the G-Codes and m codes from system to system.

## 12.14 CNC TURNING A GEAR BLANK

Figure 12.50 shows the cross section of a part to be machined in a CNC lathe. Providing for facing and turning allowances the blank (Fig. 12.51) have a diameter of 71 mm and length 24 mm.

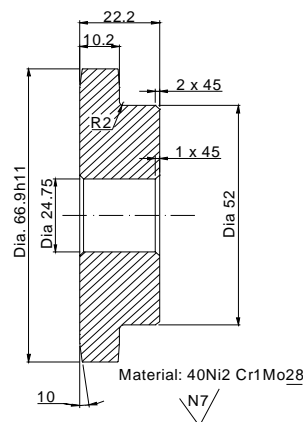


Fig. 12.50 Drawing of the Component



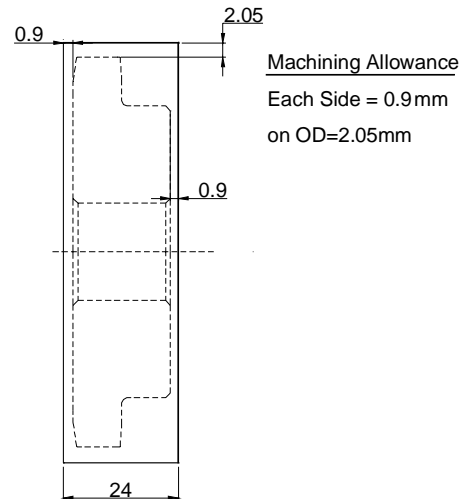


Fig. 12.51 Blank

**Machining Requirements:**

The material of the gear is 40 Ni2Cr1MO28 (Medium Carbon alloy steel). The surface finish required is N7 corresponding to a centre line average (CLA value) of 1.6 mm. This means that the machining operation requires roughing and finishing.

**Process Design:**

Components of this type requires two end operations. These are termed as first and second operation. The machining process involved in these two stages of operation are given in the table 12.17 and table 12.18.

Table 12.17 Process Sheet for First Operation

Operation number	Operation	Tool Holder	Insert	Cutting speed (m/min)	Speed rpm	Feed (mm/rev)	Depth of cut (mm)	Remarks
1	Center drill	Jacob chuck	HSS	16	1020	0.2	—	T02
2	Φ20mm Drill	Drill adaptor	HSS	20	320	0.2	—	T04
3	Rough Facing & Turning	PCLNL	CNMG 120412 -PR	420	1995	0.1	0.7-F2-T	T01
4	Finish Turning	PTLNL	TNMG 160404 -PF	450	2140	0.05	0.2-F0.05-T	T03

Contd....

5	24.25 mm Rough boring	PTFNL	TNMG 160404	80	1050	0.1	2.125	T06
6	24.75mm finish boring	PTFNL	TNMG 160404	100	1285	0.05	0.25	T06

Work Material: 40Ni2Cr1M028      Hardness :229-277 BHN

**Table 12.18 Process Sheet for Second Operation**

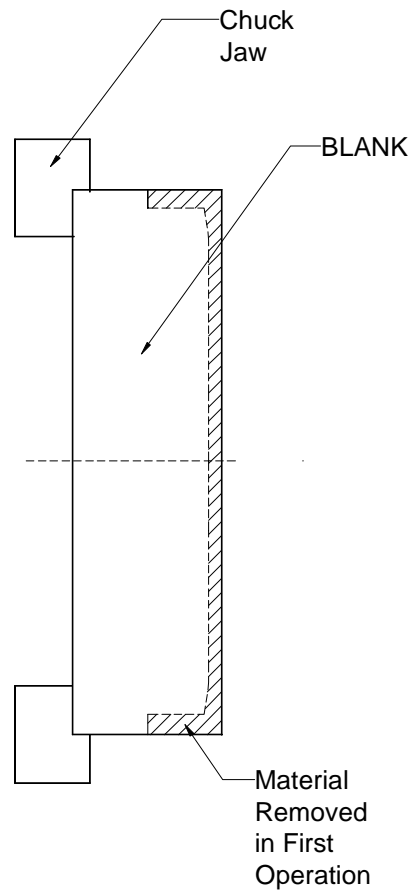
<i>Operation number</i>	<i>Operation</i>	<i>Tool Holder</i>	<i>Insert</i>	<i>Cutting speed (m/min)</i>	<i>Speed rpm</i>	<i>Feed (mm/rev)</i>	<i>Depth of cut (mm)</i>	<i>Remarks</i>
1	Rough Facing & Turning	PCLNL	CNMG 120412 -PR	420		0.1	0.7 – F 2 - T	T01
2	Finish Turning	PTTNL	TNMG 160404 -PF	450		0.05	0.2 – F 0.05 – T	T03
3	Boring	PTFNL	TNMG 160404	80	1285	0.1	1.375	T06

### ***Tool Length Offset:***

The tool length offset is the distance between the home position and the work piece datum. The work piece datum is the point at which the X and Z co-ordinates on the component is zero. Normally, for cylindrical parts the datum is fixed along the axis on the finished surface of the workpiece.

Procedure for setting the work piece datum:

- i. First the tool turret is moved to the machine datum (home position). Here the values of X and Z will be zero.
- ii. The tool is then moved in JOG mode / MPG mode and it is touched on the face of the component. The Z value shown will be the tool length offset. This value is entered in the offset page or allowance for facing shall be added with this value if needed.
- iii. The tool is then touched along the periphery of the component. The X value noted at this position is added with the radius of the component to set the X datum along the axis. This value is entered in the tool offset page.



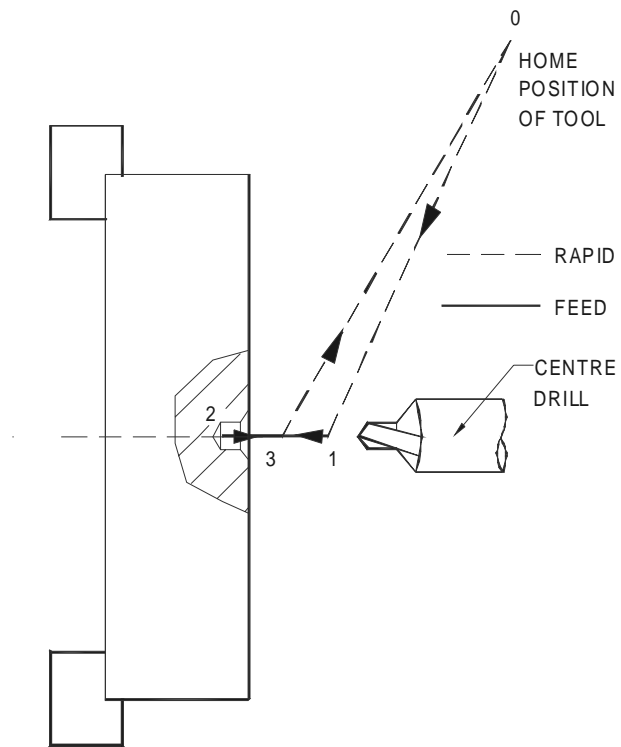
**Fig. 12.52 The Setting for the First Operation**

**Program for First Operation:** Figure 12.52 shows the setting for the first operation.

<b>Seq. No.</b>	<b>Program</b>	<b>Description</b>	<b>Position</b>
00001 ;		(Program number)	
		(centre drilling)	
N10	G21;	(Metric data input)	
N20	G28 U0 W0 ;	(Home position)	
N30	M06 T0202 ;	(Tool change, Tool No.2, Offset value 02)	
N40	M03 S1020 ;	(Spindle rotate CW at 1020 rpm)	
N50	G00 X0 Z5	(Rapid positioning)	0-1
N60	G01 Z-5 F 0.2;	(Centre drilling)	1-2

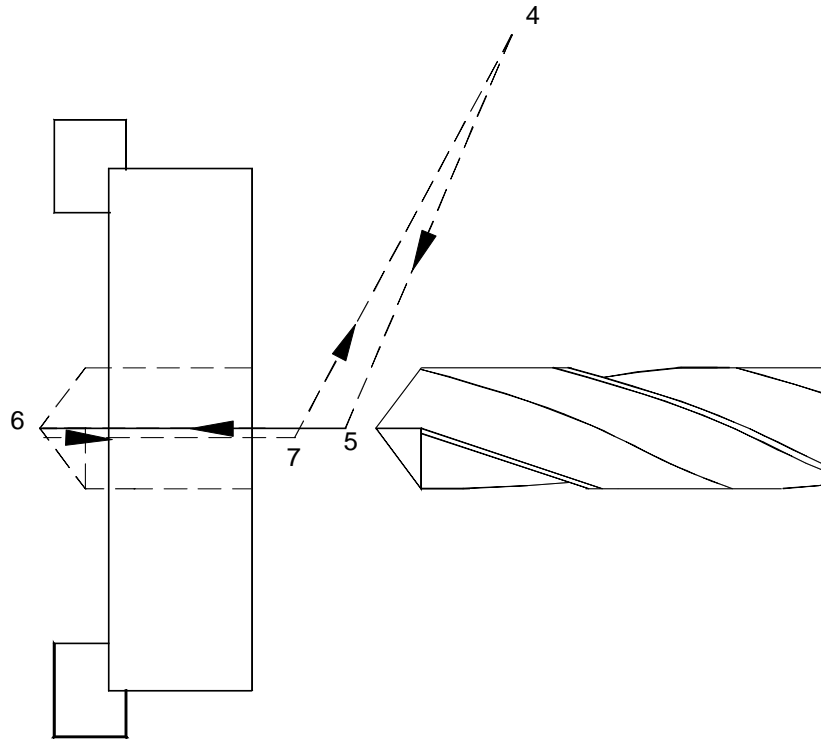
*Contd....*

<b>Seq. No.</b>	<b>Program</b>	<b>Description</b>	<b>Position</b>
N70	G00 Z3;	(Rapid positioning)	2-3
N80	G28 U0 W0 ;	(Home position)	3-0



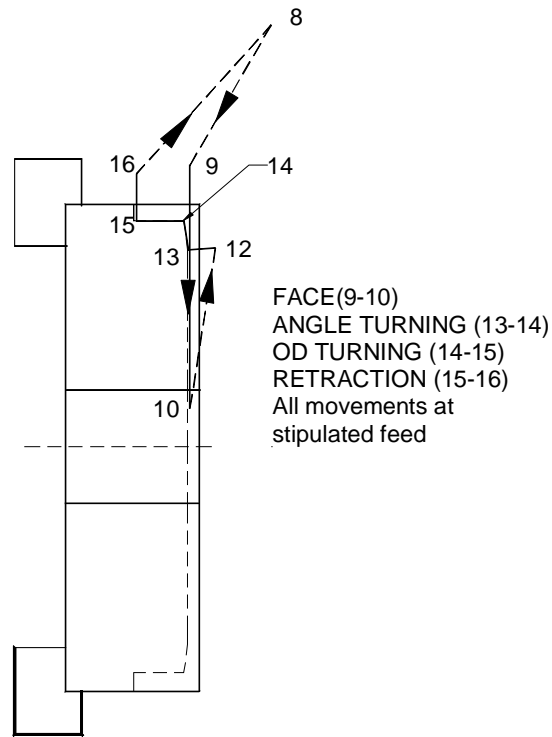
**Fig. 12.53 The Central Drilling**

(drilling)			
N90	M06 T0404	(Tool Change, Tool No.4, Offset value 04)	
N100	M03 S320;	(Spindle rotate CW at 320 rpm)	
N110	G00 X0 Z5 ;	(Rapid positioning)	4-5
N120	G01 Z-25 F0.2 ;	(Drilling)	5-6
N130	G01 Z3	(Retract)	6-7
N140	G28 U0 W0;	(Home position)	7-4



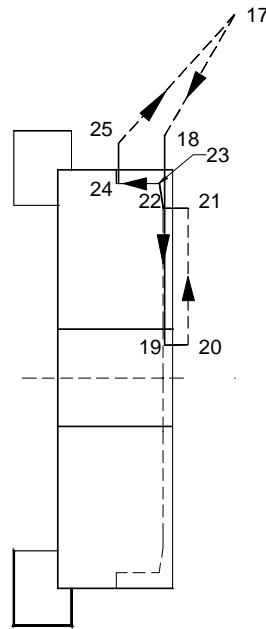
**Fig. 12.54 Drilling**

<b>Seq. No.</b>	<b>Program</b>	<b>Description</b>	<b>Position</b>
(Facing and turning - Roughing)			
N150	M06 T0101	(Tool Change, Tool No.1, Offset value 01)	
N160	M03 S1995	(Spindle rotate CW at 1995 rpm)	
N170	G00 X75 Z0.2	(Rapid positioning)	8-9
N180	G01 X19 F0.1 ;	(Rough Facing)	9-10
N190	G00 Z2 ;	(Rapid Positioning)	10-11
N200	G28 U0 W0;	(Home position)	11-12
N210	G01 Z0.2	(Feed Positioning)	12-13
N220	G01 X67 Z-06728 F0.1 ;	(Rough Taper Turning)	13-14
N230	G01 Z-11 F0.1 ;	(Rough Turning)	14-15
N240	G01 X75 ;	(Feed Movement)	15-16
N250	G28 U0 W0 ;	(Home position)	16-8



**Fig. 12.55 Facing and Turning (Rough)**

<b>Seq. No.</b>	<b>Program</b>	<b>Description</b>	<b>Position</b>
(Facing and Turning - Finishing)			
N260	M06 T0303	(Tool Change, Tool No.3, Offset value or)	
N270	M03 S2140;	(Spindle rotate CW at 2140 rpm)	
N280	G00 X75 Z0;	(Rapid Positioning)	17-18
N290	G01 X19 F0.05;	(Finish Facing)	18-19
N300	G00 Z2;	(Rapid Positioning)	19-20
N310	G00 X57 ;	(Rapid Positioning)	20-21
N320	G01 Z0 ;	(Feed Movement)	21-22
N330	G01 X66.9 Z-08728 F0.05;	(Finish Taper Turning)	22-23
N340	G01 Z-11 ;	(Finish Turning)	23-24
N350	G01 X75;	(Rapid positioning)	24-25
N360	G28 U0 W0;	(Home position)	25-17



**Fig. 12.56 Facing and Turning (Finish)**

<b>Seq. No.</b>	<b>Program</b>	<b>Description</b>	<b>Position</b>
<b>(Rough Boring)</b>			
N370	M06 T0606;	(Tool Change, Tool No.6, Offset value o6)	
N380	M03 S1050;	(Spindle rotate CW at 1050 rpm)	
N390	G00 X28.25 Z2;	(Rapid Positioning)	26-27
N400	G01 X24.25		
	Z-1 F0.1;	(Chamfer)	27-28
N410	G01 Z-25;	(Straight Boring)	28-29
N420	G01 X23;	(Feed Movement)	29-30
N430	G00 Z2 ;	(Rapid positioning)	30-31
N440	G00 X28.75	(Rapid Positioning)	31-32
<b>(Finish boring)</b>			
N450	G01 X24.75		
	Z-1 F0.05;	(Chamfer)	32-33
N460	G01 Z-25;	(Straight boring)	33-34
N470	G01 X23;	(Feed Movement)	34-35
N480	G00 Z3;	(Rapid positioning)	35-36
N490	G28 U0 W0;	(Home position)	36-26
N500	M30;	(Program stop & rewind)	

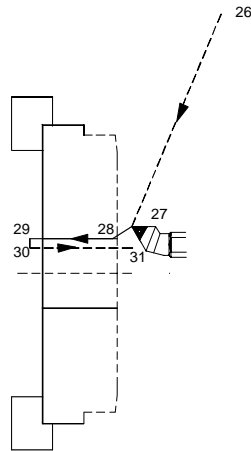


Fig. 12.57 Rough Boring

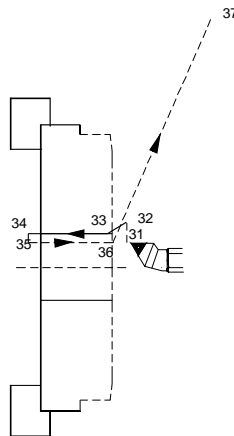


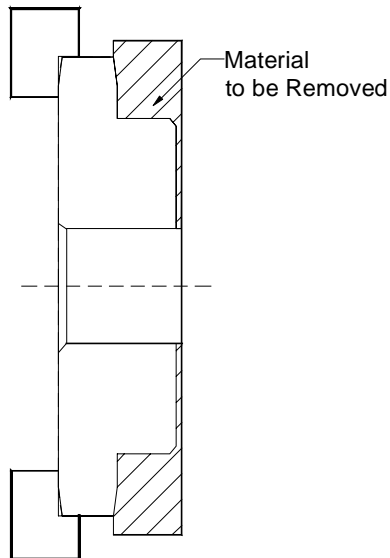
Fig. 12.58 Finish Boring

**Program for Second Operation:** Refer to Fig 12.59 for set up. Fig 12.60 shows the sequence of roughing.

Seq. No.	Program	Description	Position
O0002 ;		(Program number)	
N10	G21;	(Metric data input)	
N20	G28 U0 W0;	(Home position)	
N30	M06 T0101;	(Tool change, Tool No.2, Offset value 02)	
N40	M03 S1995;	(Spindle rotate CW at 1995 rpm)	
N50	G00X75 Z0.2 ;	(Rapid positioning)	0-1
N60	G01 X19 F0.1;	(Rough Facing)	1-2



N70	G00 Z2 ;	(Rapid positioning)	2-3
N80	G00 X75 ;	(Rapid positioning)	3-4
N90	G00 Z0.2;	(Rapid positioning)	4-5
N100	G71 U2 R1 ;	(Turning Cycle)	
	U - Depth of cut 2 mm		
	R- Relief amount 1 mm		
N110	G71 P120 Q170		
	U0.05 W0.05 F0.1 ;	(Turning cycle)	
	P - Starting block number 120 of the profile		
	Q - Ending block number 170 of the profile		
	U - Finishing allowance in X axis 0.05 mm		
	W - Finishing allowance in Z axis 0.05 mm		
	F - Feed 0.1 mm/rev		
N120	G01 X 47.6 F0.1 ;	(Rough turning)	1-5
N130	X52 Z-2 ;	(Rough turning)	5-6
N140	Z-10 ;	(Rough turning)	6-7
N150	G02 X56 Z-12 R2 ;	(Circular interpolation)	7-8
N160	G01 X57 ;	(Feed Movement)	8-9
N170	X 66.9 Z-12.8728 ;	(Taper turning)	9 - 10
N180	G28 U0 W0 ;	(Home position)	10-0



**Fig. 12.59 Second Operation (Material to be removed)**

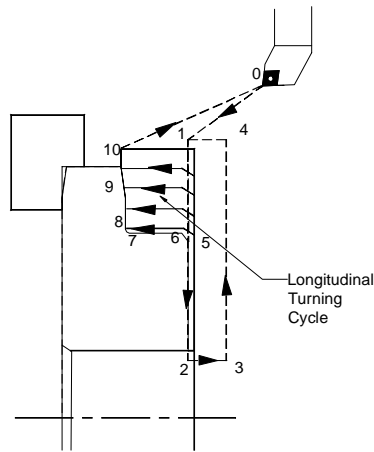


Fig. 12.60 Longitudinal Turning Cycle

Seq. No.	Program	Description	Position
N190	M06 T0303 ;	(Tool change, Tool No.3, Offset value 03)	
N200	M03 S2140 ;	(Spindle rotate CW at 2140 rpm)	
N210	G00 X75 Z0 ;	(Rapid positioning)	0-1
N220	G01 X19 F0.05 ;	(Finish facing)	1-2
N230	G00 Z2 ;	(Rapid positioning)	2-3
N240	G00 X75 ;	(Rapid positioning)	3-4
N250	G00 Z0;	(Rapid positioning)	4-1
N260	G70 P120 Q170 F0,05 ;	(Finishing cycle)	5 to 10
N270	G28 U0 W0 ;	(Home position)	10-0

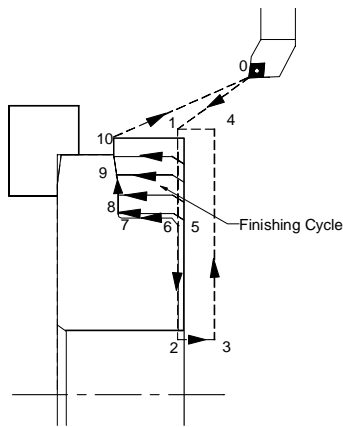
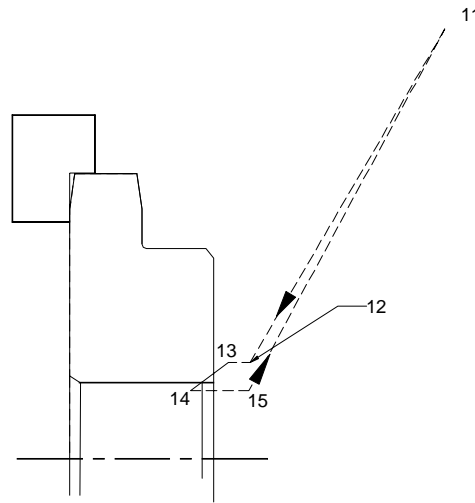


Fig. 12.61 Finish Machining Operation

<b>Seq. No.</b>	<b>Program</b>	<b>Description</b>	<b>Position</b>
N280	M06 T0606 ;	(Tool change, Tool No.6, Offset value 06)	
N290	M03 S1285 ;	(Spindle rotate CW at 1285 rpm)	
N300	G00 X28.75 Z5	(Rapid positioning)	11-12
N310	G01 Z1 F0.05;	(Feed Movement)	12-13
N320	G01 X23 Z-1.875 ;	(Chamfer)	13-14
N330	G00 Z5 ;	(Rapid positioning)	14-15
N340	G28 U0 W0;	(Home position)	15-11
N350	M30 ;	(program stop & rewind)	



**Fig. 12.62 Chamfering**

## 12.15 CNC TURNING A CASTING

### 12.15.1 PROCESS DEFINITION

Process selection or process definition is an important step in the programming process. The process should be so designed that the component to be manufactured should be realized meeting all the dimensional accuracy and quality requirements.

The first thing a programmer should know the material of the component (work). The cutting speed is selected on the basis of the work material and the tool materials as well as the expected life of the cutting edge. For economic reasons a tool life of 15 minutes is usually acceptable in CNC machining. Cutting speed also depends on the machinability of the material, feed and depth of cut. Tables of cutting data supplied by the tool manufacturers are available and the programmer can select the cutting speed from these tables.

The programmer should decide whether rough machining and finish machining operation should be carried out separately or roughing only is adequate. For surface finishes of (equivalent to  $1.6 \mu\text{m}$  to  $3.2 \mu\text{m}$  CLA roughness) the component can be finished only by roughing. For surface finish of (equivalent to  $0.8 \mu\text{m}$  to  $1.6 \mu\text{m}$ ) finish turning is essential.

The Figure 12.63 shows a grey cast iron component. The hardness of FG200 grey cast iron varies between 179 to 223 BHN. The cutting speed is selected accordingly. A careful study of the drawing will reveal that the important dimension is the bore with the tolerance of H8 and a surface finish  $R_a$  of  $1.6 \mu\text{m}$ . The other important dimension is 220 mm diameter which should be concentric with respect to the 40 mm diameter bore within 0.01 mm.

The face of the component should be perpendicular to the bore within 0.01 mm.

The component is machined in two steps (first operation and second operation). The process sheets for both operations are shown in Table 12.19 and Table 12.20.

The bore size is 40 H8. Since the bore tolerance is a tight one the process should consist of a rough boring operation followed by a finish boring operation. To maintain the required concentricity and face perpendicularity, the finish boring operation is performed in the second operation.

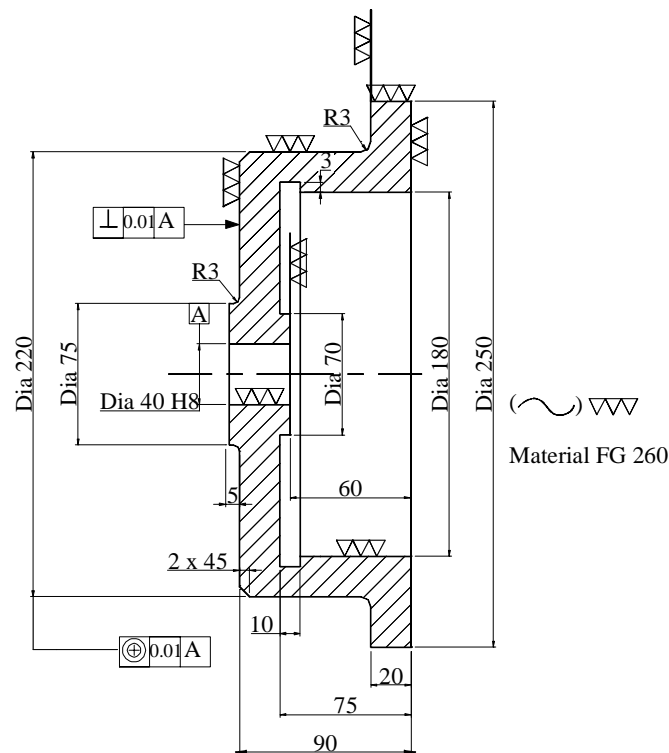
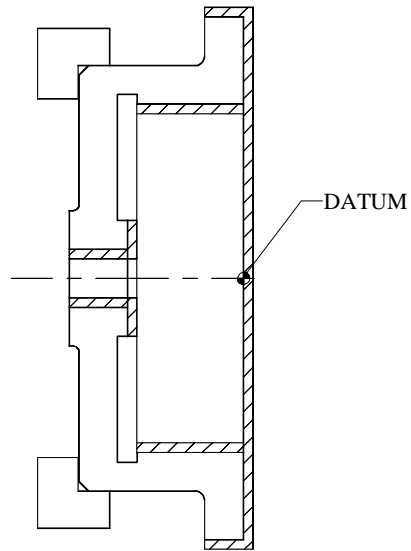
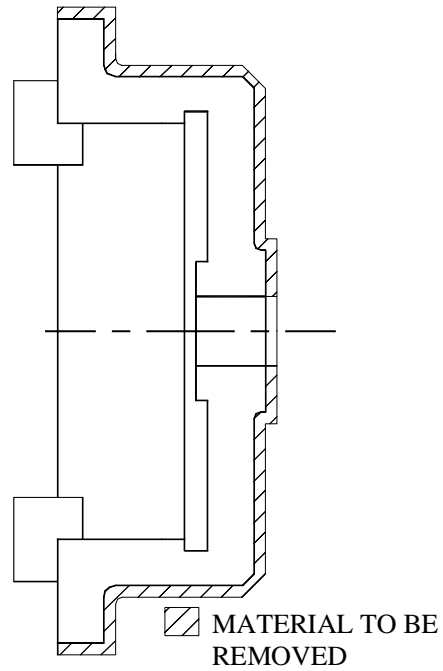


Fig. 12.63 Drawing of the Component



 MATERIAL TO BE REMOVED

**Fig. 12.64 First Operation Setting**



 MATERIAL TO BE  
REMOVED

**Fig. 12.65 Second Operation Setting**

**Table 12.19 Process Chart for First Operation**

<i>Operation number</i>	<i>Operation</i>	<i>Tool Holder</i>	<i>Insert</i>	<i>Cutting speed (m/min)</i>	<i>Speed rpm</i>	<i>Feed (mm/rev)</i>	<i>Depth of cut (mm)</i>	<i>Remarks</i>
1	Rough Turning & Facing	PCLNL	CNMG 120408 -MR	160	220	0.2	2	T01
2	Finish Turning & Facing	PCLNL	CNMG 120404 - MR	200	260	0.1	1	T03
3	Finish Boring	SDUCL	DCMT 11T304 - UF	200	1600	0.1	0.25	T02

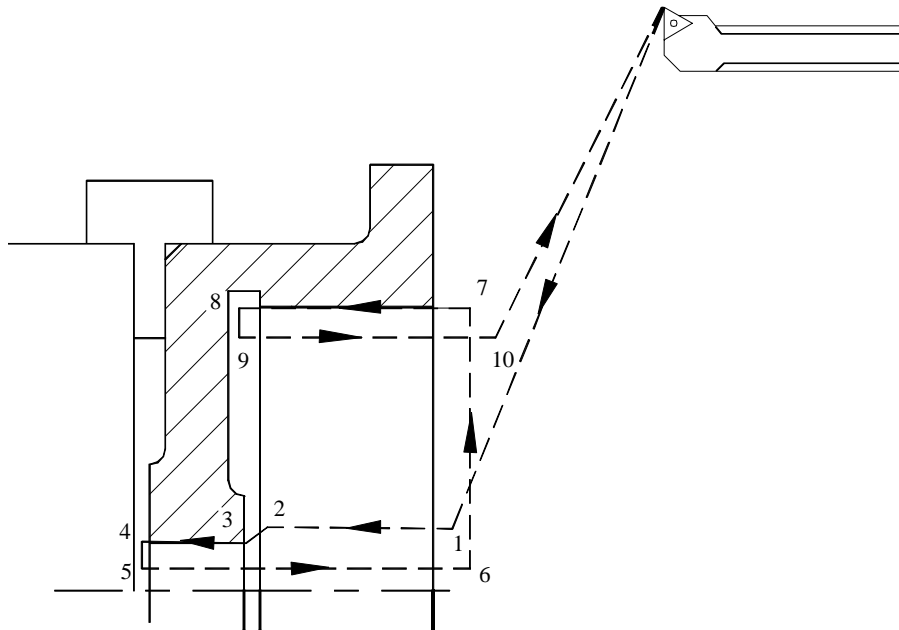
**Table 12.20 Process Chart for Second Operation**

<i>Operation number</i>	<i>Operation</i>	<i>Tool Holder</i>	<i>Insert</i>	<i>Cutting speed (m/min)</i>	<i>Speed rpm</i>	<i>Feed (mm/rev)</i>	<i>Depth of cut (mm)</i>	<i>Remarks</i>
1	Rough Boring	SDUCL	DCMT 11T308 -UM	175	1400	0.3	2.75	T02
2	Rough Turning & Facing	PCLNL	CNMG 120408 -MR	160	200	0.2	3	T01
3	Rough Facing	SCLCR	CCMT 120408 -UM	160	720	0.2	3	T04

**Program for First Operation**

<i>Seq. No.</i>	<i>Program</i>	<i>Description</i>	<i>Position</i>
O0001;		(Program number)	
N10	G21	(Metric data input)	
N20	G28 U0 W0;	(Home position)	
N30	M06 T0202 ;	(Tool change, Tool No.2, Offset value 02)	
N40	M03 S1400;	(Spindle rotate CW at 1400 rpm)	
N50	G00 X53 Z5 ;	(Rapid positioning)	
N60	G00 Z-55;	(Rapid positioning)	
N70	G01 X40 Z-61 F0.2 ;	(Chamfer)	

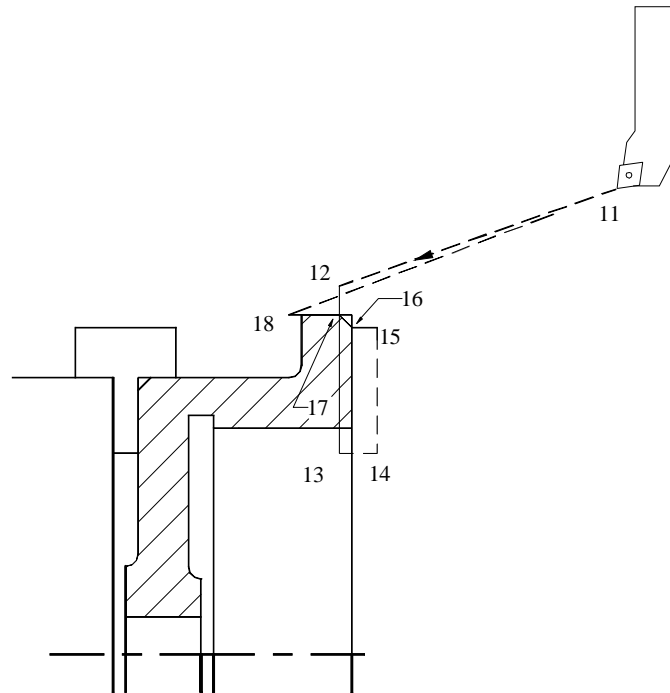
N80	G01 Z-97 F0.2 ;	(Boring))
N90	G00 X38;	(Rapid traverse)
N100	G00 Z5;	(Rapid traverse)
N110	M03 S320	(Rapid traverse)
N120	M03 S320;	(Spindle rotate CW at 320 rpm)
N130	G01 Z-72 ;	(Boring)
N140	G00 X175;	(Rapid traverse)
N150	G00 Z5;	(Rapid traverse)
N160	G28 U0 W0;	(Home position)



**Fig. 12.66 Boring**

<b>Seq. No.</b>	<b>Program</b>	<b>Description</b>	<b>Position</b>
N170	M06 T0101 ;	(Tool change, Tool No.1, Offset value 01)	
N180	G96 S160	(Constant surface speed control cutting speed 160 m/min)	
N190	G00 X258 Z0 ;	(Rapid positioning)	11-12
N200	G01X170 F0.2 ;	(Facing)	12-13
N210	G00 Z3;	(Rapid positioning)	13-14
N220	G00 X248 ;	(Rapid positioning)	14-15

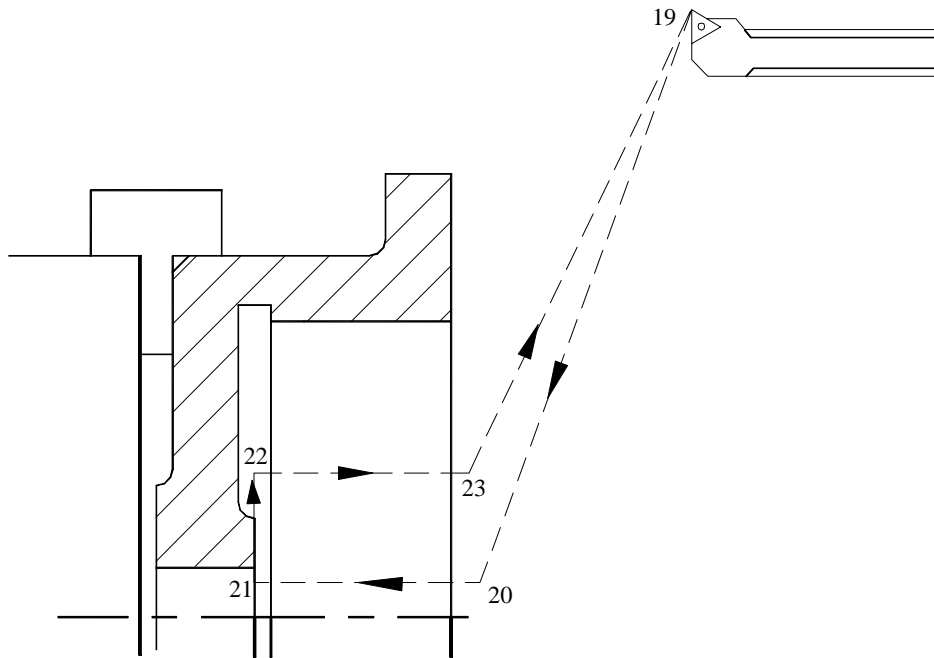
N230	G01 Z0;	(Feed traverse)	15-16
N240	G03 X250 Z-1 R1 F0.2;	(Radius)	16-17
N250	G01 Z-22 F0.2;	(Turning)	17-18
N260	G97 G28 U0 W0;	(Home position)	18-11



**Fig. 12.67 Facing and Turning**

<b>Seq. No.</b>	<b>Program</b>	<b>Description</b>	<b>Position</b>
N270	M06 T0404	(Tool change, Tool No.4 Offset value 04)	
N280	G96 S160 ;	(Constant surface speed control ) cutting speed 160 m/min	
N290	G00 X38 Z3;	(Rapid positioning)	19-20
N300	G00 Z-60 ;	(Rapid positioning)	20-21
N310	G01 X76 ;	(Facing)	21-22
N320	G00 Z3 ;	(Rapid positioning)	22-23
N330	G28 U0 W0;	(Home position)	23-19
N340	M30;	(Program end and rewind)	



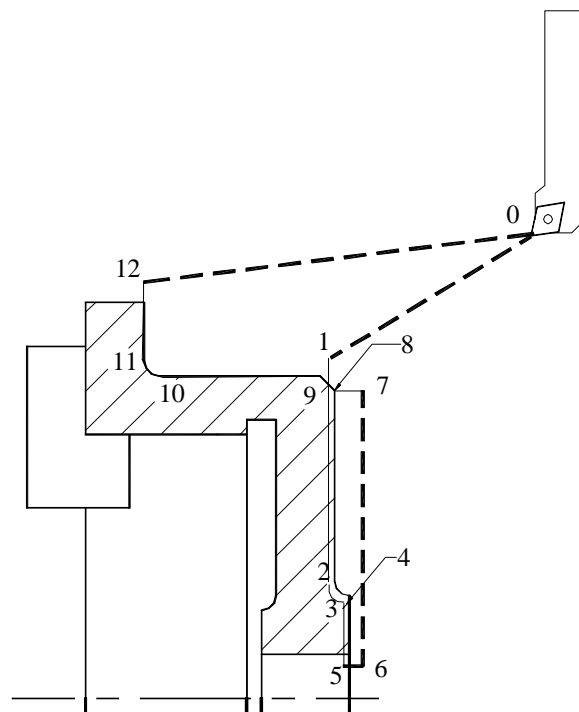


**Fig. 12.68 Machining the Hub**

**Program for Second Operation:**

<b>Seq. No.</b>	<b>Program</b>	<b>Description</b>	<b>Position</b>
O0001;		(Program number)	
N10	G21G97;	(Metric data input)	
N20	G28 U0 W0;	(Home position)	
N30	M06 T0101 ;	(Tool change, Tool No.1, Offset value 01)	
N40	G96 S160;	(Constant surface speed control Cutting speed 160 m /min)	
N50	G00 X230 Z-4.5 ;	(Rapid positioning)	0-1
N60	G01 X82 F0.2 ;	(Facing)	1-2
N70	G02 X76 Z-2.5 R3 F0.2;(Radius)		2-3
N80	G01 Z-0.5;	(Turning)	3-4
N90	G01 X38;	(Facing)	4-5
N100	G00 Z3;	(Rapid positioning)	5-6
N110	G00 X216;	(Rapid traverse)	6-7
N120	G00 Z-4.5	(Rapid traverse)	7-8

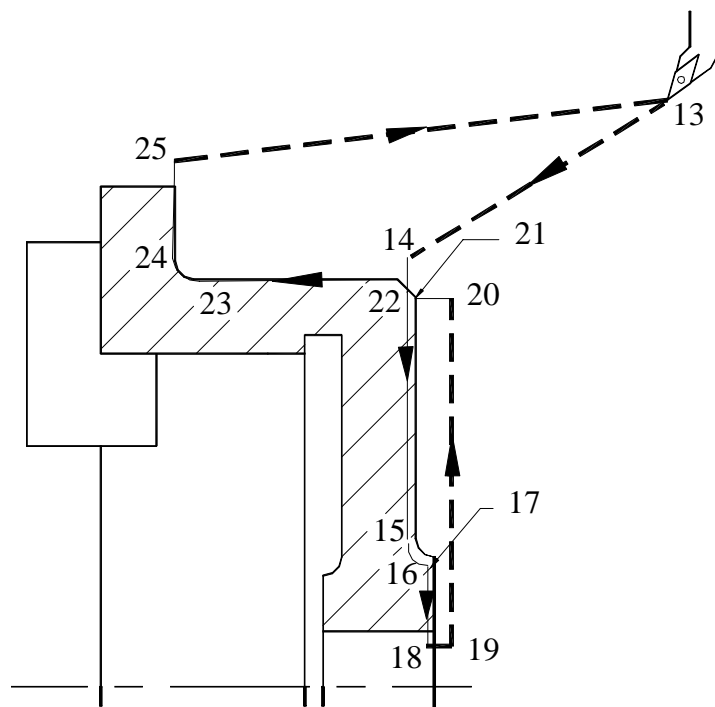
N130	G01X221 Z-7;	(Chamfer)	8-9
N140	G01Z-71.5;	(Turning)	9-10
N150	G03 X225 Z-74.5 R3;	(Radius)	10-11
N160	G01 X249 F0.2;	(Turning)	11-12
N170	G02 X250Z-76 R1 ;	(Radius)	12-13
N180	G01 X255 F0.3;	(Feed rate positioning)	13-14
N190	G97 G28 U0 W0;	(Home position)	14-0



**Fig 12.69 Facing and OD Turning (Second Operation)**

<b>Seq.No.</b>	<b>Program</b>	<b>Description</b>	<b>Position</b>
N200	M06 T0303 ;	(Tool change, Tool No.3, Offset value 03)	
N210	G96 S200 ;	(Constant surface speed control Cutting speed 200 m/min)	
N220	G00 X223 Z-5;	(Rapid positioning)	15-16
N230	G01 X81 F0.1 ;	(Facing)	16-17
N240	G02 X75 Z-2 R3 F0.1;	(Radius)	17-18

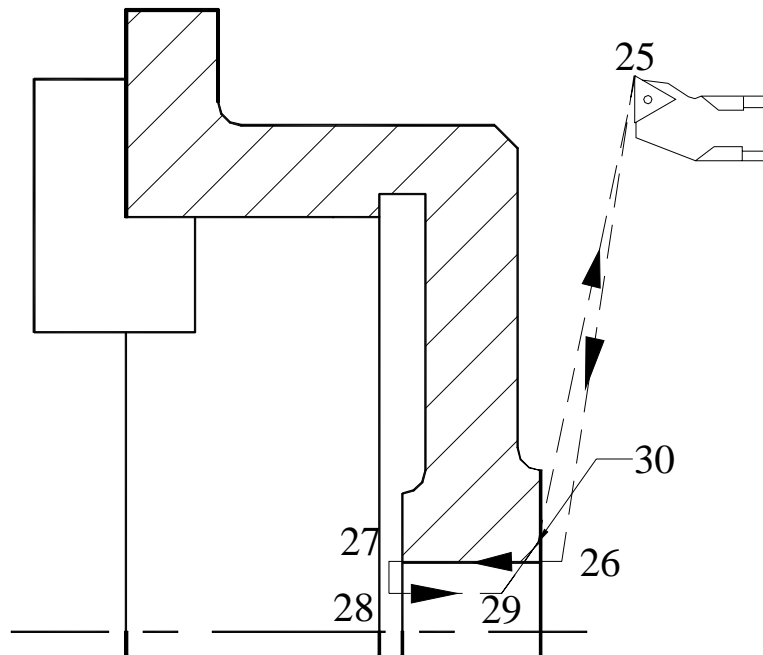
N250	G01 Z0 ;	(Turning)	18-19
N260	G01 X38;	(Facing)	19-20
N270	G00 Z3;	(Rapid Positioning)	20-21
N280	G00 X216;	(Rapid traverse)	21-22
N290	G00 Z-5 ;	(Rapid traverse)	22-23
N300	G01 X220 Z-7 ;	(Chamfer)	23-24
N310	G01 Z-72;	(Turning)	24-25
N320	G03 X226 Z-75 ;	(Radius)	25-26
N330	G01 X248 F0.1 ;	(Turning)	26-27
N340	G02 X250 Z-76 R1;	(Radius)	27-28
N350	G01 X255 F0.3;	(Feed rate positioning)	28-29
N360	G97 G28 U0 W0;	(Home position)	29-15



**Fig. 12.70 Finishing**

<b>Seq. No.</b>	<b>Program</b>	<b>Description</b>	<b>Position</b>
N370	M06 T0202	(Tool change, Tool No.2, Offset value 02)	
N380	M03 S1600;	(Spindle rotate CW at 1600 rpm)	

N390	G00 X40.0065 Z3;	(Rapid positioning)	30-31
N400	G01 Z-38 F0.1;	(Boring)	31-32
N410	G00 X38 ;	(Rapid positioning)	32-33
N415	G00 Z1 ;	(Rapid positioning)	33-34
N420	G00 X44 ;	(Rapid positioning)	34-35
N425	G01 X38 Z-2 ;	(Chamfer)	35-36
N440	G00 Z5;	(Rapid positioning)	36-37
N450	G28 U0 W0 ;	(Home position)	37-30
N460	M30 ;	(Program end & Rewind)	



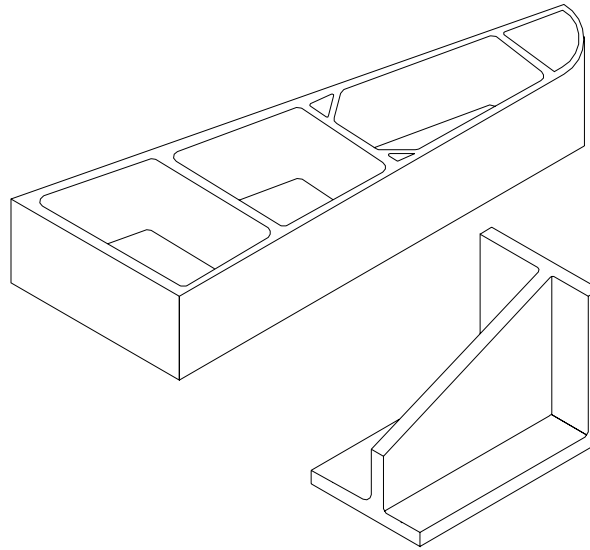
**Fig. 12.71 Boring**

### 12.16 CNC PROGRAM DEVELOPMENT AND VIRTUAL MACHINING USING CAM TECHNOLOGY

The integration of CAD and CAM has resulted in a paradigm shift in the methodology of NC programming. To day it is possible not only to generate CNC program required to manufacture a component directly from the CAD model but also design and model the fixturing set up, design the blank, process plan, select optimum process parameters, and simulate the machining operations on the CAD/CAM workstations to ensure that the program is capable of producing acceptable components.

### 12.16.1 NEED FOR GENERATING LARGE PROGRAMMES

Numerical control was initially developed to meet the requirements of the aerospace industries. In many cases these components are to be milled from solid aluminum billets in order to ensure structural integrity on the components. It is therefore quite common to start machining a workpiece weighing several hundred kilograms and the final component may have only a weight of a few kilograms. Figure 12.72 shows a typical aircraft structural component. In order to reduce the weight, the structures are made thin. In order to ensure that the structural member is able to withstand the heavy stresses and strains during the operation it is necessary to provide ribs. The geometry is often complex with doubly curved surfaces which necessitate 5-axis machining.



*Fig. 12.72 Typical Aircraft Structures*

Such machining operations require several thousands of blocks and it is tedious to write such complex programmes. Thus the need for developing computer techniques for NC program development was felt right from the beginning of numerical control itself.

### 12.16.2 DRAWBACKS FOR MANUAL PROGRAMMING

Manual programming of aircraft structures is very difficult because of the sheer size and complexity of these programs. Mathematical calculations involved in 5-axis contouring is time consuming and tedious. A programmer is liable to make mistakes and detection and elimination of mistakes is a time consuming activity. Moreover writing NC codes of 20 or 30 thousand lines manually is a stupendous task.

These programming operations will involve complex calculations to determine the co-ordinates of points for the positioning of tools. Many issues like incorporation of cutter

diameter compensation make these calculations very involved. Further, errors if undetected will result in enormous wastage in terms of materials and time resulting in over runs in project time and cost.

### 12.16.3 DEVELOPMENT OF COMPUTER AIDED MANUFACTURING

Because of the reasons mentioned in the previous section the need for computer tools for program development was felt early in the history of NC. MIT developed APT in 50's and for a long time APT used to be the most commonly used software for computer aided NC programming. APT (acronym for **A**utomatic **P**ositioning of **T**ools) was originally developed by Massachusetts Institute of Technology . Later Illinois Institute of Technology Research Institute, Chicago developed APT further. An organization called CAM-I was carrying out developments in APT after IITRI . Depending on the computer on which APT was implemented there were several versions of APT namely, UNIAPT (Univac Computer), NELAPT (National Engineering Laboratory), FAPT (Fujitsu Fanuc), ADAPT (IBM), AUTOSPOT (IBM), CINTURN (Cincinnati Milacron), COMPACT-II (Manufacturing Data Systems International), GENTURN (General Electric), MILTURN (Metal Institute, Netherlands), NEL (Ferranti), SPLIT (Sundstrand), EXAPT (Technische Hochschule, Aachen) etc. Several other computer aided programming softwares were also available to the programmers in '60s and '70s.

The approach to computer aided part programming in these softwares is as follows:

- i. **Definition of geometry (Geometry statements):** The geometry of the component is defined with statements like POINT, LINE, PLANE, CIRCLE, CYLINDER, ELLIPSE, VECTOR, CONIC, TABCYL (Ta BULATED CYLINDER) ETC. Using these statements the geometry of the component can be completely defined.
- ii. **Motion statements:** The tool assumed to around the workpiece to carry out the machining operations. Commands like GO, GODLTA, GOTO, OFFSET, TLLFT, GOLFT, GOUP, TLNDON, etc., are used to define the tool movements.
- iii. **Post processor statements:** It is necessary to specify the cutter details, spindle speed, feed rate, tolerances etc., and these are included in the post processor statements. FEDRAT, COOLNT, CUTTER, TOLER, etc., were the typical post-processing statements.

The APT processor will create a cutter location data file (CL Data file) which is basically a text file containing the co-ordinates of the points to be visited by the tool. It is necessary to modify this and convert it into a NC program to suit a particular combination of a machine tool and a control system. Since the specifications and capabilities of machine tools and the features of the control systems vary widely it is essential to develop separate post processors to create NC programs for each machine tool and control system combination.

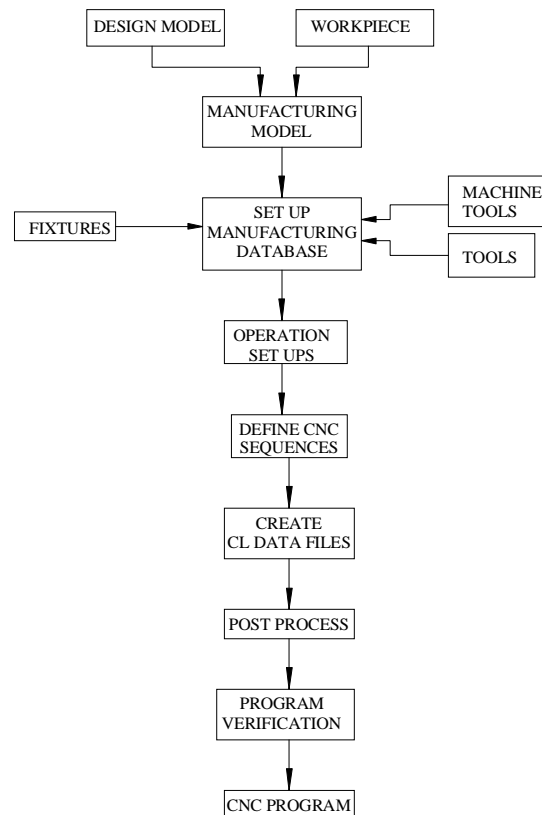
APT was the forerunner of the present CAD/CAM technology. The developments in CAD and CAM has made this approach of program creation obsolete. To day the

geometry of the component can directly be obtained from the 3-D CAD model. CAM softwares can create the NC program from the geometry data. The steps involved in the part program development using CAM softwares are described in the next section.

## 12.17 TECHNOLOGY OF CAM

The block diagram shown in Fig.12.73 illustrates the steps involved in creating a NC program using a CAM software package. The starting point of CAM is the CAD file. A common approach is the program creation carried out using solid models or surface models. Data for program creation can also be obtained from SAT (ACIS solids), IGES, VDA, DXF, CADL, STL and ASCII file using suitable translators.

- i. Create a manufacturing model from the design model and the workpiece.
- ii. Set up the tool database. Tools must be defined before an operation is performed. Tool libraries can be created and retrieved for a manufacturing operation. Alternatively, they also can be created at the time of defining the manufacturing operation.



**Fig. 12.73 Steps Involved in NC Program Creation**

- iii. Select the set up for the machining operation. A component may require more than one set up to complete the machining operation.
- iv. Fixtures are necessary for each set up. Fixtures can be displayed along with the workpiece. This is to ensure that the path of the tools does not interfere with the tools. Fixtures consist of the locating and clamping elements to hold the workpiece on the machine table during the machining operation. In the case of a turning operation appropriate chucking devices should be used. Standard fixture elements can be created as a library of parts and assembled before the manufacturing operation is commenced. These are also available as standard libraries.
- v. Create a machinability database. Parameters like spindle speed and feed rate can be selected from the machinability database.
- vi. Create the manufacturing operations to generate the CL data. As each manufacturing operation takes place, material is removed from the workpiece to simulate the actual manufacturing operation. This simulation is enhanced by the tool path being displayed for each operation.
- vii. If needed the CL data can be modified by modifying the operation parameters or by editing the CL data file.
- viii. Create a manufacturing route sheet at the end of the manufacturing session.
- ix. Post-process the CL file to create the NC program.

There are several popular CAM packages available today. Some of them are listed below:

- PRO/Manufacturing
- CVCNC
- I-DEAS generative Manufacturing
- UG - Manufacturing
- Surf CAM
- Virtual Gibbs
- Edge CAM
- Prospector
- Master CAM
- Cimatron

The next section describes in detail the procedure of creating a NC program using a CAM software.

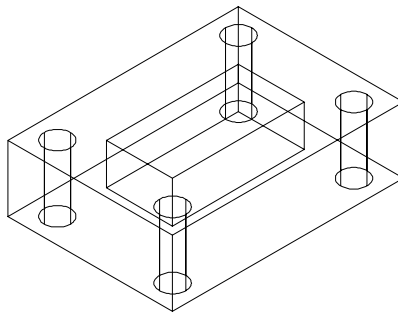
### 12.18 PROCEDURE OF CAM

The CAD model represents the finished product. This is used as a basis for the manufacturing operations. Features, surfaces and edges are selected on the design model as references for each manufacturing operation. Referencing the geometry of the design model sets up parametric relationship between the design model and the workpiece.



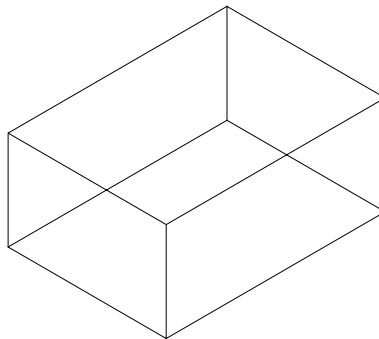
Because of this relationship, when the design model is changed, all associated manufacturing operations are updated to reflect the change.

The workpiece is the raw material from which the component is obtained after the manufacturing operations. The workpiece can be bar stock, casting, billet, forging etc. It may be easily created by copying the design model and modifying the dimensions or deleting or suppressing the features to represent the real workpiece.



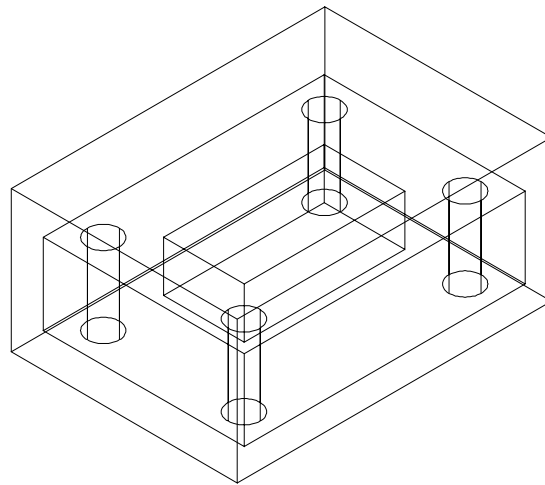
**Fig. 12.74 Design Model**

For example consider the model of the component shown in Fig. 12.74. The raw material for this component is a cast aluminum part. It is necessary to create a datum surface on the component for initially locating it on the fixture or the machine table. This operation is often performed separately. In the case of the component shown in the figure the bottom surface can be conveniently taken as the datum. The component is to be milled on the top surface as well as the sides. Dimensions of these surfaces must be increased by the amount of material to be removed (machining allowance). There are also a number of bored holes. Material is to be added in these locations corresponding to the machining allowance. When the size of the bored hole is less than 30 mm in diameter, it is usual practice not to provide a core while making the casting. Such features should be machined from solid. There are also a number of drilled holes. These holes will not be present in the casting. Thus from the design model a workpiece is evolved.



**Fig. 12.75 Workpiece**

The workpiece is shown in Fig. 12.75. The design model and the workpiece are then assembled together to form the manufacturing model. Figure 12.76 shows the manufacturing model. The outer solid lines show the design model and the inner lines show the workpiece.



**Fig. 12.76 Manufacturing Model**

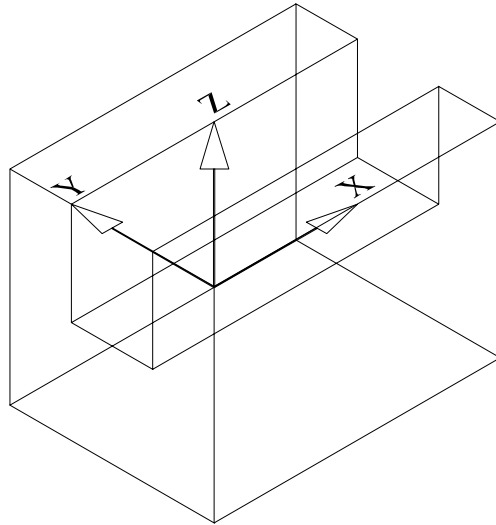
In the case of aluminum parts for aerospace applications it may be necessary to start manufacturing from a billet. The machining allowances to be added to the envelope of the workpiece to obtain the length, breadth and the height of the billet. In the case of a turned part the raw material may be a casting or bar stock. In the former case machining allowance is to be added. It may also be necessary to eliminate dimensionally small features like threads, grooves, fillets, chamfers, holes etc., which can be created during the machining operation. In the case of bar stock the workpiece is often a plain cylindrical part.

### **12.18.1 SELECTING CO-ORDINATE SYSTEM**

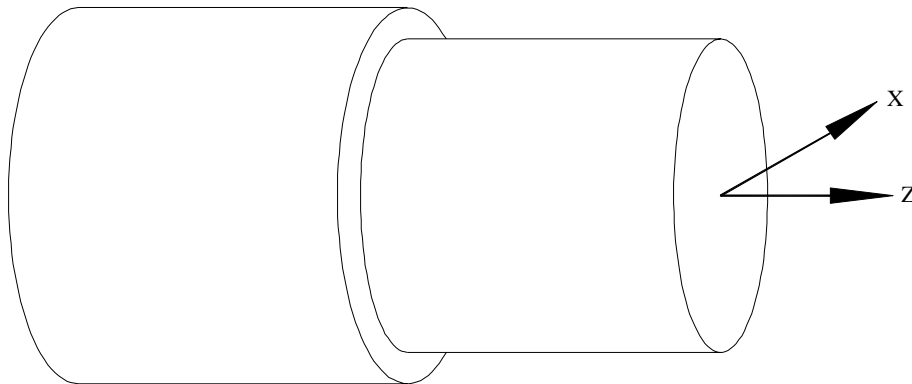
Co-ordinate systems are vital components in manufacturing. They define the orientation of the workpiece on the machine and act as the origin of the CL data generation. The co-ordinate system can belong to the workpiece or the design model.

### **12.18.2 Z-AXIS ORIENTATION**

During the manufacturing operations the co-ordinate systems should be oriented in such a way that the positive Z-axis points away from the holding fixture. For example Fig. 12.77 shows the orientation of the Z-axis for the machining operations to be performed on the top surface of a component. The orientation of the component for turning is shown in Fig. 12.78.



**Fig. 12.77 Z-axis Orientation for a Milled Part**



**Fig. 12.78 Z-axis Orientation for a Turned Part**

### **12.8.3 X- AND Y-AXIS ORIENTATION**

The orientation of X and Y axes of the operation co-ordinate system will affect the CL data file. In milling the main cut feed direction will be parallel to the X-axis.

### **12.18.4 FIXTURES**

As mentioned in the last section fixtures are parts or assemblies which help to hold and orient the workpiece during a machining operation. Fixtures can be created as and when needed.

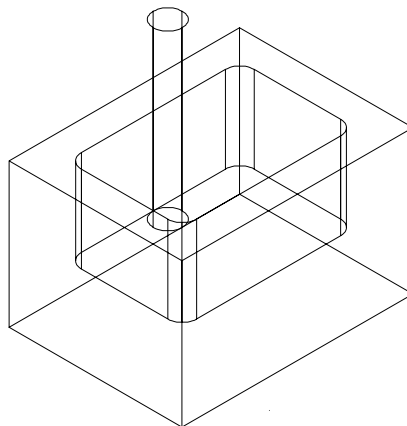
## 12.19 MANUFACTURING OPERATIONS

Important manufacturing operations are discussed in this section.

### 12.19.1 MILLING

The milling operations normally performed can be classified into a number of groups.

- i. **Volume milling:** In this case a closed volume is to be removed in the milling operation. This approach is used for rough face milling or pocket milling operations. A speciality of volume milling is that the tool will always be within the milling volume. To define the milling volume the geometry of the design model is referenced the volume to be milled is to be sketched and this volume is to be intersected with the workpiece model. A typical example of volume milling is shown in Fig. 12.79.



**Fig. 12.79 Volume Milling**

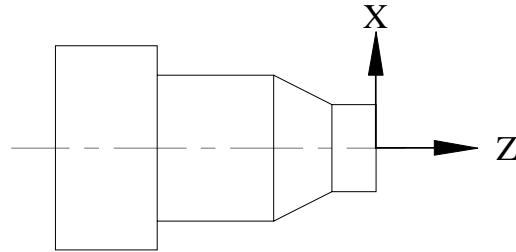
- ii. **Surface milling:** A surface of the component can be selected for the milling operation. Examples are 3-, 4- or 5-axis milling of the surfaces, profiling, pocket finishing etc. There are two types of surface milling operations:
  - a. Conventional surface milling: This operation generates a tool path which will completely machine the specified surface.
  - b. Trajectory milling: Certain milling operations can be performed by specifying a trajectory. Examples are milling of slots, face milling operations, and many end milling operations.

### 12.19.2 NC TURNING

The approach to NC program creation in turning is different from that of milling. The procedure is briefly described in the following sections:

### ***Co-ordinate setting***

In NC turning the Z-axis is usually collinear with the turning axis. Therefore, the turning cut is sketched in the XZ plane. The typical co-ordinate setting is shown in Fig. 12.80



**Fig. 12.80 Co-ordinate Setting in NC Turning**

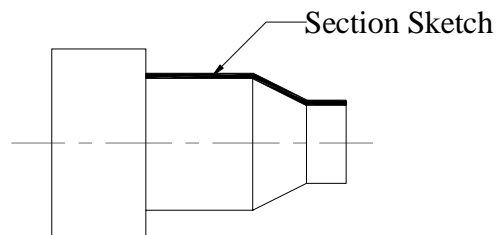
### ***Defining turn profile***

The profile (outline) of the workpiece is to be defined in the to generate the tool path. A CAM software provides several facilities to create the profile. Some of the common facilities are:

- i. Sketching the profile.

The profile of the cut can be sketched as shown in Fig.12.81.

- ii. Using surfaces to define a profile
- iii. Using a curve to define a turn profile

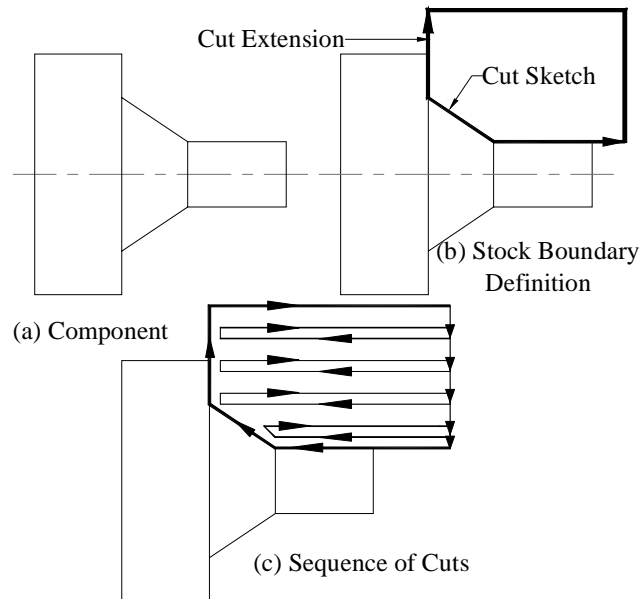


**Fig. 12.81 Sketching the Cut**

### ***Stock boundary and area turning***

It is often convenient to define the stock boundary and then create the NC sequences through the area clearance approach. Figure 12.82 (a) shows a component to be machined. The stock boundary can be defined as shown in Fig. 12.82 (b). Area turning allows the programmer to define the stock material removed graphically. The tool path will be generated by scanning this area to remove the material in step depth increments.

The successive cuts for machining this area are shown in Fig. 12. 82 (c).



**Fig. 12.82 Stock Boundary Definition and Area Turning**

### **Profile turning**

Profile turning allows the programmer to interactively specify the cut motion trajectory. The profile can be specified as outside, inside, and face. This influences the tool orientation and location with respect to the trajectory of cut.

### **Groove turning**

Grooves are a common feature on turned components. This is carried out by a plunge cutting tool with a flat end and cutting edges on either side. Groove turning can be inside, outside, or on the face. When the width of the groove is more than the width of the tool, the distance between the neighboring cuts by the step-over parameter. When the depth of the groove is large peck cycles are used in rough groove turning.

### **Thread turning**

Threads commonly provided on the turned components may be external or internal. Holes for internal threads may be blind or through. The thread sequences are defined by sketching the first tool movement which corresponds to the major diameter of an external thread and to the minor diameter of an internal thread. The thread depth is calculated based on the pitch of the thread by a parameter `THREAD_FEED`.

### 12.19.3 DRILLING HOLES

Hole making NC sequences include drilling, reaming, boring, tapping etc. These operations have to be carried out both in turning machines and machining centres. A hole making NC sequence is created by selecting the cycle type and specifying the holes to drill by defining the hole sets. A hole set includes one or more hole to be drilled. Each hole set will have a drilling depth specification or countersink diameter value associated with it. A single hole making sequence may include more than one hole set enabling the programmer to drill holes with different depth specifications as well as having multiple countersink diameter values.

There are various methods of selecting the holes to be included in hole set.

- i. By selecting individual hole axis
- ii. By including all holes on a selected surface
- iii. From a hole containing the co-ordinates of the datum points
- iv. By including all datum points on a specified surface
- v. By including all holes of a specified diameter
- vi. By including individual datum points on specified surface

A CAM software may contain several types of hole making options.

- Drill** - Standard, deep, or break chip
- Face** - Drill a hole with an optional dwell at the final depth to assure a clean surface at the bottom of the hole
- Bore** - Bore a hole with a finish hole diameter of high precision.
- Ream** - Create a precision finish hole using a multi-edge reamer.
- Countersink** - Drill a chamfer at the entry of the hole.
- Tap** - Drill a threaded hole.

### 12.20 TOOL MOTION PARAMETERS

A number of tool motion parameters are to be input to create a NC program. Some of them are:

FEED\_RATE  
CUTCOM (Tool compensation)  
COOLANT  
SPINDLE\_SPEED  
SPEED\_SENSE  
MAX\_SPINDLE\_RPM  
SPINDLE\_RANGE

```
CLEAR_DIST  
PULL_OUT_DIST  
LEAD_RADIUS  
LEAD_STEP  
APPROACH_DISTANCE  
EXIT_DISTANCE
```

### 12.21 AUXILIARY NC SEQUENCES

These are used to create a point-to-point tool path. They can be used to specify the connecting tool motions and change tool axis orientation. The machine probe functionality can also be accessed using these sequences. Some typical auxiliary sequences are:

```
GOTO POINT  
GO DELTA  
GO HOME  
FOLLOW SKETCH
```

### 12.22 CL DATA FILES

Cutter Location (CL) data files are generated from the cutter paths specified within the NC sequences. Each NC sequence generates a separate CL file. They can be merged together to produce a single file for the whole operation. These CL data files can be post-processed by machine specific or generic post-processors for the creation of the NC program. A sample file is shown below:

```
$$* xxx/CLfile Version 2.1  
$$->MFGno/T  
PARTNO CASING  
$$->FEATNO/21  
MACHIN/HMTMILL,600  
$$->UNITS/MM  
LOADTL/16  
COOLNT/ON  
FROM/0.00000000, 0.00000000, 0.00000000  
SETSTART/0.00000000, 0.00000000, 25.00000000  
RAPID  
GOTO/150.00000000,120.00000000, 120.00000000  
SPINDL/RPM,600
```



```
FEDRAT/100.00000000,MMPM  
CYCLE/DRILL, -75.0, 100.00000000, MMPM  
RAPID  
GOTO/0.00000000, 0.00000000, 0.00000000  
CYCLE/OFF  
SPINDL/OFF  
$$->END/  
FINI
```

The CL data can be used to display the tool path. This feature will help to locate errors in the program. The CL data can be edited and modified by rotation, translation, mirroring and scaling.

### 12.23 NC POST-PROCESSING

The specifications and capabilities of a CNC machine tool will vary from one to another. There are a number of manufacturers of CNC control systems and each system will have a number of versions which will be different with regard to their features. The CL files require to be modified to generate a NC program from the CL data to suit a machine tool-control system combination. This procedure is called post-processing and CAM softwares usually incorporate a software module called generic post-processor for this purpose. Usually the MACHIN statement is used to select the post-processor. A GENER statement will retrieve all the necessary information about the NC machine from the database. The NC program thus created can be stored, listed or simulated on the screen for editing or modification if needed, or transferred to a CNC machine using DNC. The NC program can also be checked using a software like VERICUT.

### 12.24 VIRTUAL MACHINING

Creation of programs through CAM software packages is a significant development. This method eliminated the drudgery involved in writing large programs. Errors are reduced and thereby wastage is avoided. However, it is still necessary to prove the program as there are so many factors which will influence the acceptability of the component. Gouging is a common problem encountered in creating complex surfaces. Improper programming may remove more material or leave material on the workpiece un-removed. Errors in geometry or tool motion statements may result in a workpiece whose dimensions after machining may not be acceptable. Dry runs and program prove out on the machine are always time consuming and costly. Hence it is desirable to simulate the machining program on the computer to verify the program.

Program verification softwares which are now available as a module of CAM software packages are a useful tool to carry out machining on the computer workstation. Since the

machining is carried out in a virtual environment it is called virtual machining. This enables the programmers to visualize and modify the program until they are completely satisfied about the program. It helps to remove all moves that would have gouged the part. Cuts deeper than what is required are also detected. The experience of the users of virtual machining indicates that it is possible to straight away proceed to machining metals and usual problems encountered in machining like tool breakage, collisions and tool wear due to long run times are avoided. The tool library built into the system enables the programmers to select the tool of the actual shape and dimensions used on the shop floor for simulation.

### 12.25 SUMMARY

CNC is an important development in manufacturing. A broad overview of the technology with brief description of some of the recent developments has been presented in the foregoing sections. As a technology which is highly influenced by the developments in microprocessors, microelectronics and information technology, CNC is a still evolving technology. The factors which made CNC technology popular in recent years are listed below:

- i. With the downsizing of large companies, jobs are subcontracted to smaller shops where the use of CNC machines has proved profitable.
- ii. Introduction of PC based CNC machines and windows based CAM software packages has made CNC programming and operation user friendly.
- iii. CAM software packages make it easy to translate CAD files into CNC programs which enable users handle sophisticated jobs and schedule work for greater productivity and profit.
- iv. The cost of CNC machine tools has come down considerably.

### QUESTIONS

1. What is the most popular type of drive for CNC machines today?
2. Sketch and explain the torque speed characteristics of a spindle drive.
3. Why is a gearbox used in the main drive of some CNC machines?
4. Why is separate cooling motor used with DC drives?
5. List the advantages of AC servomotors over DC servomotors.
6. Why is a servomotor used for axes feed drive?
7. Why is often a reduction drive using timing belt, employed in feed drives?
8. What is the advantage of servomotors with built-in encoders?
9. What are the four common types of ball screw mounting arrangements?
10. What are the advantages of Linear Motion guide ways?
11. What is the type of plastic insert used in CNC machine sideways?
12. What is the purpose of using LM guides or plastic inserts in sideways?
13. What is the advantage of using slant bed design for turning machines?

14. Why should a brake be used with the X-axis drive in a slant bed lathe?
15. What is the principle of operation of a linear motor?
16. How is the turret of a CNC lathe indexed?
17. What is a bi-directional turret?
18. Why are not axial tools kept in adjacent pockets in a tool turret?
19. Why is a poly V belt preferred for main drive ?
20. What is the advantage of using a linear transducer for feedback measuring?
21. What is the advantage of using an absolute measuring system?
22. What is the advantage of using an analog measuring system?
23. Describe the principle of working of two analog transducers.
24. Explain the principle of working of two digital incremental transducers.
25. What is a Digital Read Out (DRO) ?
26. What is an A/D converter ? Where is it used in a CNC Machine?
27. Name three types of bearings used in the mounting of spindles of CNC machines.
28. Why is sometimes a spindle oil cooler necessary?
29. Is it necessary to keep a CNC machine in an A/C room?
30. What type of microprocessors are used in modern CNC systems?
31. What is the advantage of multiprocessor CNC system?
32. Name three techniques of interpolation.
33. Give major specifications of a machining centre.
34. Give major specifications of a CNC lathe.
35. What are the differences between a CNC lathe and a turning centre?
36. What is a typical tool changing time in a modern high speed machining centre?
37. How is the slide position referenced?
38. What is meant by accuracy?
39. What is meant by repeatability?
40. How is a CNC machine calibrated?
41. What are the following G Functions for a lathe?  
G04, G09, G27, G54, G7642.
42. What are the following G Functions for a machining centre?  
G17, G30, G81, G99
43. What are the following M functions for a machining Centre?  
M03, M19, M06
44. Write and explain the standard format of G01 code in a CNC lathe.
45. What is a user macro?
46. What is the purpose of a tool pre-setter?

47. What are the D and H codes in a machining centre program?
48. How is a tapered thread cut in a machining centre?
49. How is a program number designated?
50. What is the difference between absolute and incremental programming?
51. Specify Nine linear axes as per ISO.
52. Specify the different combinations of axes of a 5-axis machining centre.
53. What are the axes of a 4 axes machining centre?
54. Name the roughing and finishing tool holders in a CNC lathe for turning.
55. Name the turning inserts for the above.
56. What is the difference between BT taper and ISO taper for machining centres?
57. What is the code for tool nose radius compensation in a lathe?
58. What is the G code for cutter diameter compensation in milling?
59. Describe the types of milling operations available in a CAM software.
60. Describe the common tool motion statements available in a CAM software.
61. Discuss the stock boundary definition and area clearance in a CAM software.
62. What is the speciality of a tapping tool holder in a machining centre? What is the significance of rigid tapping?
63. Why is ceramic tool advantageous than carbide tools in CNC turning?
64. Why is a curvic coupling preferred in indexing devices in a CNC machine?
65. What are the common types of automatic tool changers?
66. Why is a pull stud used in the tool holder of a machining centre?
67. How is clamping and unclamping carried out in fixing the tool in the machining centre?
68. Why is a soft jaw used in CNC turning?
69. How does an chip conveyor work?
70. How is post process metrology carried out in a CNC machine?
71. What are the override switches provided on the control panel?
72. What is optional stop?
73. What is the difference between M00 and M30?
74. What is the difference between EIA code and ISO code?
75. What are the features of a PC based CNC?
76. Name the loading devices used in CNC lathes to improve productivity.
77. What is a PLC ?
78. How is tool life monitored in a CNC lathe?
79. How is tool offset measured in the machine?
80. What is the purpose of post processing?

81. What is a CL data file?
82. What is a universal machining centre?
83. Why is a ball nose cutter used in machining of curved surfaces?
84. What is background programming ?
85. What is meant by conversational programming?
86. What is a 'soft key' in a CNC panel?
87. What is dry run?
88. What is simulation?
89. What is DNC operation of CNC machines?
90. What is radius programming?
91. In which G function do you incorporate chamfer command?
92. What G code do you use to machine sharp corners?
93. What is a canned cycle?
94. What are the various methods of selecting a holes on hole set for drilling holes in a CAM software?
95. What are the advantages of using CAM softwares ?
96. What is a word address block format?
97. Differentiate among design model, workpiece model and manufacturing model in a CAM software.
98. Define the process, write the operation sheet, sketch the set ups and write the NC program for turning the following components.
99. A Cast iron slab of width 600 mm is milled with a face milling cutter of 200 mm diameter. How many passes are needed to completely mill the entire surface? Sketch the successive paths. What is the step over feed?
100. An aluminum billet of 200 mm width and 600 mm long is milled using a face milling cutter of 250 mm diameter in one pass. If the air cut distance at the beginning and at the end of cut is equal to 8 mm estimate the length of cut. If the feed rate used is 800 mm/min calculate the time required for one cut.
101. A 16 mm hole is drilled in a cast iron work piece of 50 mm thick. Calculate the feed stroke if (a) the depth of the hole is 30 mm and (b) if the hole is a through hole.
102. Define the process, plan the set up and fixtures, select the tools, prepare the operation sheets and write/create NC programs for the components given below:

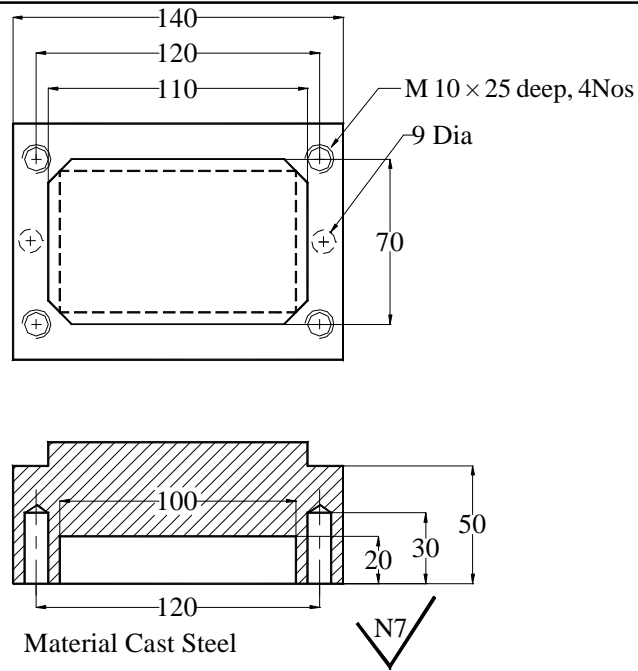


Fig. 12.83 Die Block

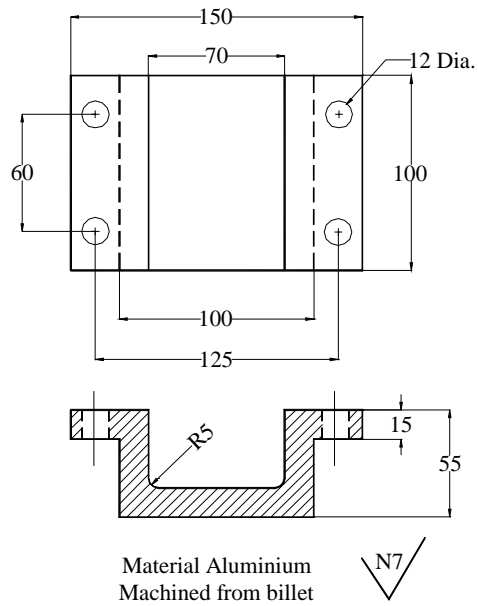
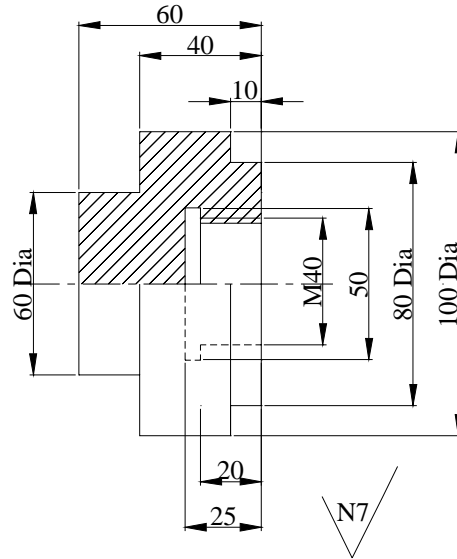
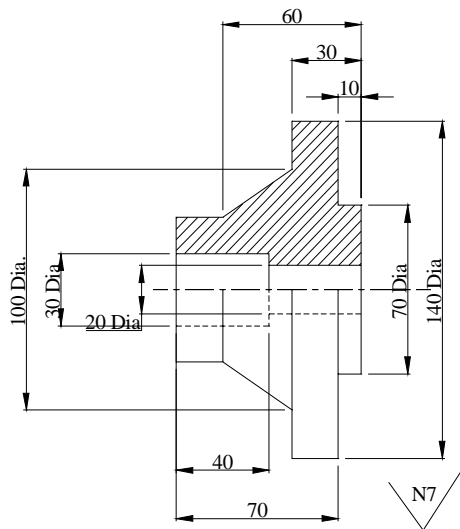


Fig. 12.84 Support



Material: Aluminium

**Fig. 12.85 CAP**



Material: Phosphor Bronze

**Fig. 12.86 Bush**

# ROBOTS IN COMPUTER INTEGRATED MANUFACTURING

*The introduction of robots in manufacturing plants has helped to integrate materials handling and several manufacturing operations. To understand the role of Robots in Computer Integrated Manufacturing (CIM) and to appreciate what robots can do in production operations, one must start with the basics of the Robot technology. The objective of this chapter is to provide a basic understanding of the hardware and software that make up a typical robotic system and to present to the reader various issues involved in the use of robots.*

## 13.1 INTRODUCTION

Robots perform several tasks in factories. Some of them are:

- i. Movement of materials on the shop floor  
(Automated guided vehicles (AGV) or rail guided vehicle (RGV))
- ii. Loading and unloading of components in machines  
(Gantry robot, machine mounted robot, free-standing robot)
- iii. Inspection using vision sensors
- iv. Manufacturing operations like painting, welding, component insertion in printed circuit boards, sorting, automatic assembly, deburring, sampling, dispensing, marking, etc.

Robots are programmable machines with some human like capabilities. They are made up of mechanical components, a control system and a computer. These elements can be arranged in different ways and can vary in size and complexity to perform different tasks. Thus robots are available in a wide variety of types, which vary in their mechanical configuration, degrees of freedom of motion and type of drive and control systems. The degrees of freedom and working envelope provided by its geometric configuration are the two major selection factors of a robot. A number of different types of drive systems, each having its own advantages in cost and performance are used in robot technology. Robots are controlled by a variety of hardware and software systems. The more complex tasks usually require servo-control systems, which use sensors and microprocessors. The control system carries out the functions, which govern the robot's motion.



Robotic systems are used in a CIM environment because of they have a number of economic and performance advantages over human labor or hard automation in many manufacturing applications, particularly in batch manufacturing. The major advantages are due to their re-programmability. Robots can be programmed by several techniques. Robot programs can be very simple or extremely complex, depending on the nature of the tasks and type of motion control involved. Robot programming is often done in high-level languages that provide functions for data processing, computation, sensing and manipulation. Robot manufacturers have developed different robot languages.

The following sections give a detailed account of many of these aspects to enable the reader to understand the role of robots in a CIM environment.

### 13.2 DEFINITION OF A ROBOT

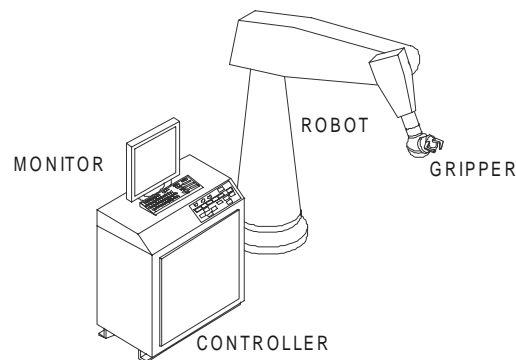
Many formal definitions have been developed to distinguish robots from other forms of automation. In general robots can be defined as “Programmable and Automatic Manipulators”. It is a special type of computer-controlled machine that can perform a wide variety of tasks. Two definitions, which are popular in industry, are quoted here. The first is by Computer Aided Manufacturing-International (CAM-I), USA:

It states that a robot is “a device that performs functions ordinarily ascribed to human beings, or operates with what appears to be almost human intelligence.”

The second definition is by Robotics Institute of America (RIA), USA. RIA defines a robot as a “programmable, multifunction manipulator designed to move materials, parts, tools, or special devices through variable programmed motions for the performance of a variety of tasks.”

#### 13.2.1 ELEMENTS OF A ROBOTIC SYSTEM

A robot is a system made up of several elements of hardware and software. These elements are illustrated in Fig. 13.1. They are briefly described below:



**Fig. 13.1 Elements of a Robotic System**

**Mechanical Components:**

They provide the physical robot motions and perform the various tasks. They include:

**(i) Components of the robot manipulator:**

- (a) A manipulator (the base and arm assembly)
- (b) End-of-arm tooling, such as a gripper or end effector
- (c) Actuators (motors or drives that move the links of the robot) and associated equipment
- (d) Transmission elements like belts, pulleys, ball screws, gearing and other mechanical components.

**(ii) Control system:**

The control system is used to generate the necessary signals co-ordinate the movements of the robot. It includes:

- (a) Mechanical, hydraulic, pneumatic, electrical, or electronic (either open loop or closed loop) controls.
- (b) Sensors including cameras, amplifiers, and related hardware.
- (c) Equipment interfaces.

**(iii) Computer system:**

This provides the data processing capability necessary to interpolate the intermediate positions and control the movement of the links or arms the robot. It includes:

- (a) Microprocessor or a programmable logic controller or a personal computer
- (b) User interfaces (e.g. keyboard, display, teach pendant)
- (c) Control software to manipulate the robot for various applications.

Robots can be configured in many different ways by using various combinations of the above elements. Since robots are designed to perform tasks that might otherwise require humans, many of their basic features are like those of a human arm. For example, an articulated robot has arm, hand, wrist and gripper to reach, grasp and manipulate objects. They are driven by a power source, which provides the energy necessary for their movements. They can be programmed or can have an intelligent control system, controlled by neural, fuzzy or fuzzy neural techniques, which can acquire, store, process and perform on the basis of the data collected by sensors attached to the robot.

**13.2.2 NEED FOR USING ROBOTS**

Robots are being used increasingly in manufacturing applications for many reasons. In many situations, they have a number of advantages over employing humans or special purpose, hard or fixed automation. The important benefits from the use of robots are listed below:

- (i) Robots can be built with performance capabilities superior to those of human beings in terms of strength, size, speed, accuracy and repeatability.

- (ii) Robots are better than humans to perform simple and repetitive tasks with better quality and consistency.
- (iii) Robots can replace humans in performing tasks that are difficult and hazardous because of factors such as size, weight, reach, precision or environment (e.g., heat (as in pressure die casting), dust (as in foundries), chemicals (detection of mines), nuclear radiation, and pollution).
- (iv) Robots do not have the limitations and negative attributes of human workers, such as fatigue, need for rest, diversion of attention, absenteeism, need for refreshments etc.
- (v) Robots can be used to perform tasks which human operators do not like to do - jobs that are considered unskilled, demeaning, or low-paying or that involve poor working conditions.
- (vi) Robots can lower costs, through reduction in usage of materials, through their efficiency and consistency.
- (vii) Robots become more economical as labor costs increase.
- (viii) Robots are flexible compared to hard automation since they can be reconfigured and reprogrammed. This permits them to be reused in new or modified applications, and they are less likely to become obsolete. The output of the humans will depend upon the learning curve every time the job is changed.

Thus robots can do jobs easier and faster to implement automation since they are more flexible. The flexibility is due to their reprogrammability. One can expect generally less down time with robots than complex hard automation in batch manufacturing operations.

Although robots may have all these advantages, they are not always the best choice for all manufacturing applications. Even though they may have a wide range of capabilities, they still cannot match the unique combination of mental skill and alertness and physical dexterity of a human operator. Robots, however, can supplement human operators to enhance their productivity.

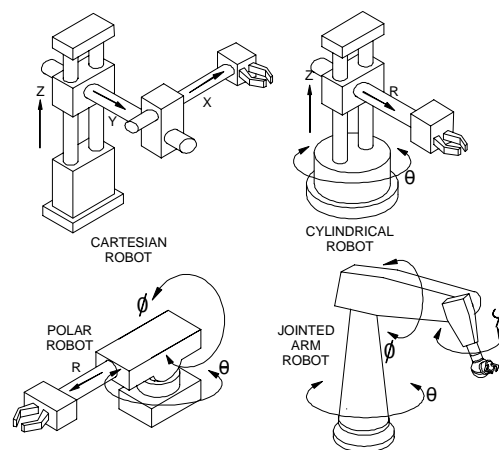
### 13.3 TYPES OF ROBOTS

Industrial robots are designed in a variety of shapes and sizes. They can be classified based on a few basic characteristic features. These are listed below:

- (i) The physical geometry of the manipulator arm and base unit and their degrees of freedom (DOF) (Movements along different axes).
- (ii) The complexity of the path in which the manipulator can move. (Point to point in the case of a pick and place robot, continuous in the case of a welding robot).
- (iii) The type of power source used to move the manipulator. (Electrical, hydraulic, pneumatic etc.).
- (iv) The techniques and systems used to control the motion of the manipulator. (Servo and non-servo).
- (v) Depending on whether the robot is stationary or mobile.

### 13.3.1 CLASSIFICATION OF ROBOTS BASED ON MECHANICAL CONFIGURATION

Four basic robot arm geometries are used for industrial applications. These are illustrated in Fig. 13.2.



**Fig. 13.2 Basic Classification of Robots**

#### 13.3.1.1 Rectangular Co-ordinate Robots

This is also known as the Cartesian co-ordinate robots. A robot with this geometry has three linear axes using sliding joints, which are typically arranged in a cantilever configuration whose motion traces a box like shape. This type of configuration is ideal for straight-line and side-to-side movements. These robots can be used for tasks involving pick and place operations like material handling and loading and unloading of work pieces in machines.

#### 13.3.1.2 Cylindrical Co-ordinate Robots

This is also referred to as a rectilinear co-ordinate robot. A robot with this geometry has three axes of motion that trace the shape of a cylinder. It has a base unit, which rotates, a vertical extension, and a horizontal arm that moves in a line. This type is best suited for movements around a base.

#### 13.3.1.3 Spherical Co-ordinate Robots

This is also known as the polar co-ordinate robot. A robot with this geometry has three axes of motion that trace the shape of a sphere. It has a base unit that rotates, a main body that tilts, and arm that slides in and out.

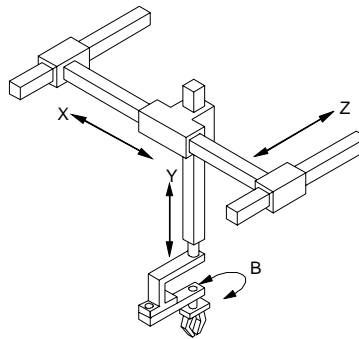
#### 13.3.1.4 Revolute Co-ordinate Robots

This configuration is also known as anthropomorphic (i.e. like a human arm) or articulated arm or jointed arm. Such a robot has three axes of motion involving a base, a shoulder, and an "elbow" that rotate.

Several variations of these basic geometries have also been developed to provide optimum performance for certain applications. Two of these are:

**i. "Gantry" or "box frame"**

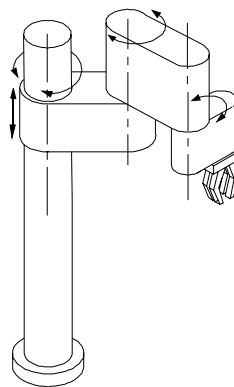
This is a rectangular co-ordinate configuration with all three linear axes of motion suspended above the work space (Fig. 13.3). It can be made very rigid, which allows high precision and high acceleration. It also lends itself to modularity in design for a variety of configurations, including multiple arms. This type of robots is used for loading work pieces in CNC turning centres in flexible turning installations. Mention of gantry robots has been made in chapter 6 and chapter 12.



**Fig. 13.3 Gantry Robot**

**ii. Selective Compliance Assembly Robot Arm (SCARA)**

This configuration shown in Fig. 13.4 is horizontally revolute. A robot of this type moves by sweeping over the workspace at a fixed horizontal distance before moving a vertical arm down. This permits a compact and relatively low cost design for small assembly tasks.



**Fig. 13.4 SCARA Robot**

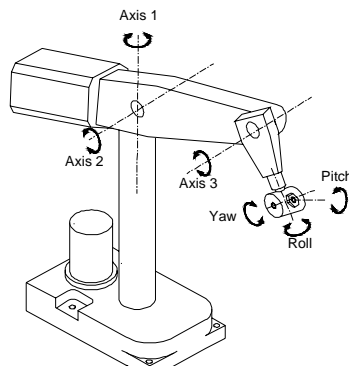
### 13.3.2 FREEDOM OF MOTION

The primary function of the manipulator is to position the arm of the robot such that it can perform its intended tasks. This requires precise and sometimes complex control of the motions of each of the mechanical elements (i.e., base and joints). To perform useful tasks, however, the robot must also grip and apply force to objects. This requires the addition of end-of-arm tooling, such as a robot hand or gripper, whose motions must also be controlled.

The motion ability of a robot is usually expressed in terms of the number of “degrees of freedom” it has. The number of axes it uses or independent moves it can make. An axis of motion can be either linear or rotational. Six geometric parameters or axis co-ordinates are required in order to completely specify the location and orientation of an object. Three co-ordinates can locate the centre of gravity of an object (e.g.,  $x$ ,  $y$ , and  $z$  co-ordinates in a rectangular co-ordinate system). Three more axes determine its orientation (e.g., angles of rotation i.e., roll, pitch and yaw). Therefore, a robot requires six degrees of freedom in order to be completely versatile in its motions.

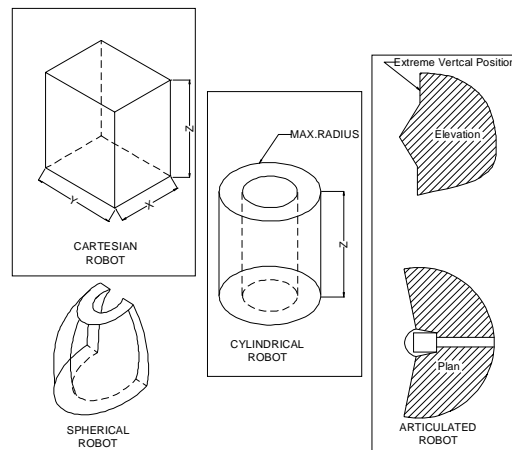
Since all of the basic mechanical configurations of manipulators provide only three degrees of freedom, additional axes must be added if more flexibility in motion is required. This is normally achieved by adding wrist and hand movements with the end-of-arm tooling (Fig 13.5). There are three basic types of wrist motions:

- i. **Roll:** Rotational or swivel movement in a plane perpendicular to the end of the arm.
- ii. **Pitch:** Rotational or bending movement in a plane vertical to the arm.
- iii. **Yaw:** Rotational or twisting movement in a plane horizontal to the arm.



**Fig. 13.5 End-of-Arm Movements**

The motion ability of a robot is also described in terms of its “working envelope”. This is the volume that can be reached by the maximum movements of the end of the robot arm. Each manipulator configuration has a different shape for its working envelope, which also varies in size with the size of the robot (Fig. 13.6).



**Fig. 13.6 Work Envelope of a Robot**

### 13.3.3 DRIVE SYSTEMS

The mechanical linkages and joints of a manipulator are driven by actuators, which can be various types of motors or valves. The energy for these actuators is provided by some power source (electric, hydraulic, or pneumatic). In some cases special technologies are used. For example, shape memory alloys are used in some specialized robotic applications. Actuators may be directly coupled to the links or joints that they drive, or through screw and nut mechanisms. There are three major types of drive systems for industrial robots:

- i. **Pneumatic Actuator System:** These systems are driven by compressed air. Pneumatic-drive robots are usually small and have limited flexibility, but they are relatively inexpensive to build and use. The weight of the payload they can carry and the speed of their motion are limited by the compressibility and low operating pressure of air. These are also particularly suitable in certain application like nuclear reactors and places where fire hazards are likely to occur.
- ii. **Hydraulic Actuator System:** These systems are driven by a fluid that is pumped through motors, cylinders, or other hydraulic actuator mechanisms. Hydraulically driven robots can be relatively compact yet provide high levels of force, power, and speed with accurate control. They can also be made very large for heavy payloads and large working envelopes. Because the power supply (hydraulic pump) can be isolated from the robot and no electric power is required in the manipulator, hydraulic robots are safe and reliable in wet, dusty, and potentially explosive environments. These types of robots are suitable for operations in foundries.
- iii. **Electric Actuator System:** These systems are driven by rotational electric motors (various types of AC Servos, DC Servos etc.). Electrically driven robots

are best suited for applications involving light payloads, which require high accuracy and fast response. They do not have some of the maintenance and reliability problems associated with pneumatic or hydraulic systems. However, they require more sophisticated electronic controls and can fail in high temperature, wet, or dusty environments. AC Servo drives are preferred now because of their ruggedness.

#### 13.3.4 CONTROL SYSTEMS

The motions of a robot are controlled by a combination of software and hardware that is programmed by the user. There are two basic types of robot control systems - servo controlled and non-servo controlled. These are described in subsequent sections.

- i. **Robot control through non-servo operation:** This is the simplest and least expensive type of control system, but it is also very limited in its flexibility and performance. It can be a purely mechanical system of stops and limit switches, which are pre-programmed or positioned for specific repetitive movements. This can provide accurate control for simple motions at low cost. Such a system can also use some type of electro- mechanical logic, such as pneumatic valves or electrical relays, to control fixed sequences of movements. The motions of non-servo controlled robots are controlled only at their endpoints, not throughout their paths. Due to the nature of the types of controls used, the number of points, which can be programmed into a sequence of movements, is also limited.
- ii. **Servo-controlled Robots:** This system is capable of controlling the velocity, acceleration, and path of motion, from the beginning to the end of the path. It uses complex control programs. Servo-controlled systems use electronic controllers (PLC's) or computers and sensors to control the motions of robots. They are more flexible than non-servo systems, and they can control complicated motions smoothly. Their capabilities and cost will vary depending on the type and sophistication of the controller and sensors involved.

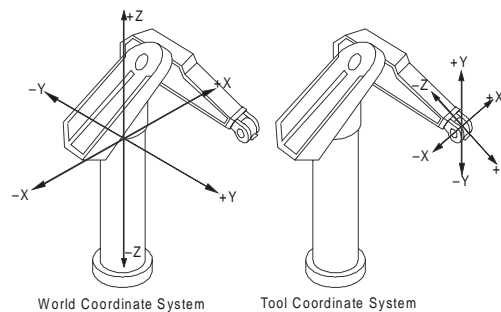
Sensors are used in servo-control systems to track the position of each of the axes of motion of the manipulator. These sensors may be located internally, in the robot joints, or externally, in the workspace. Many different types of sensors can be used depending on the nature of the task and performance requirements involved. The major functions of a control system involve:

- (i) **Generating the path of motion for the manipulator:** Assume that a robot link has to execute an angular movement. The link starts from zero angular velocity and accelerates until reaches a maximum velocity. It then continues at that velocity until it begins to approach the position it is programmed to reach. It then decelerates



until it stops at that position. The control system must provide the commands for this motion.

- (ii) **Feedback devices:** Servo-control requires feedback from sensors, which track the movements and actions of the manipulator. The signals from these sensors are read by the controller and used to make any adjustments required in the motion of the robot to achieve its task.
- (iii) **Co-ordinate transformation:** The position of the robot can be expressed in terms of the angles of its joints and the lengths of its arms. This is the “joint co-ordinate system” with which the robot must be controlled. However robot motions are usually programmed in terms of the rectangular co-ordinates of the real world (i.e. the “world co-ordinate system”). The control system must therefore convert the programmed path from one co-ordinate system to the other (Fig. 13.7). This can involve considerable amount of computation. The translated path may not be precisely the same as the one described in the original co-ordinate system program.



**Fig. 13.7 Coordinate Systems of a Robot**

- (iv) **Safety controls:** To assure that failures or errors are detected before any damage or harm is done, the actual motion of the robot must be constantly monitored and compared to allowable limits. This can involve a variety of monitoring or measuring techniques.
- (v) **Interfaces:** The control system must communicate with the user or programmer. This can be done through terminals, keyboards, control pendants, or switches (Fig. 13.8). The system controller must have interfaces to the sensors and actuators that control the motion of the robot. In some applications, the system must also communicate with other equipment, such as production machines, materials handling devices or even other robots. The communication channel provides all these interfaces to the control system.

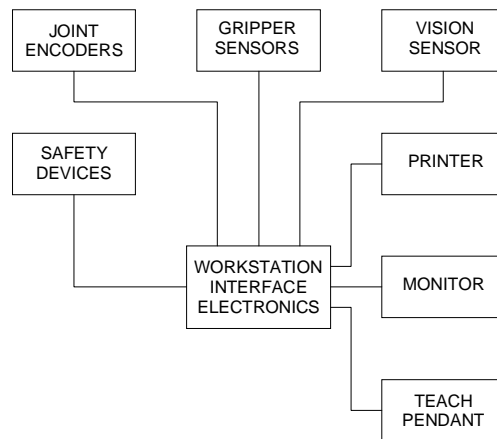


Fig. 13.8 Control System of a Robot

## 13.4 PERFORMANCE CAPABILITIES

The performance of a robot can be described in terms of many different parameters or characteristics. Their magnitude and relative importance vary depending on the inherent capabilities of the robot design and its intended applications. In general, a robot user would look for desirable characteristics such as high reliability, high speed, programmability, and low cost. However, there may be trade-offs, between even these basic characteristics. For example, increasing the speed of the robot or lowering its cost may lead to lower reliability. There is no one robot, which is best for all applications. To select one that is well suited for a particular application, the key features and specifications required must be understood and prioritized.

### 13.4.1 SPECIFICATIONS

- i. **Axes of motion:** The number of degrees of freedom of the robot's joints determines the complexity of motion it is capable of. Three degrees of freedom are provided by all basic manipulator configurations. They are adequate to locate the position of an object. Additional degrees of freedom (up to seven with some configurations, including gripper) can permit more complex motion, which can adapt to the orientation and shape of objects.
- ii. **Work envelope:** The maximum reach or range of arm movement varies in shape and size, depending on the configuration and size of the robot. The work envelope can be described in terms of degrees of rotation, vertical motion, and radial arm extension. The work envelope of the robot must obviously be compatible with all the paths and positions intended in the application.
- iii. **Speed:** The speed of the robot - which is measured at the end of the arm, where the task is to be performed - determines how fast the end-of-arm tooling or

gripper can get from one position to another. This speed will vary, depending on payload, position in the work envelope, and axis of movement.

- (iv) **Acceleration:** This is the rate at which the robot can reach its programmed speed. It can be important for complex paths, in which the time to reach maximum velocity can be a significant portion of the total travel time. The acceleration capability of a robot is determined by the power is built into the drive system. Hydraulic drives can provide very high accelerations by storing energy in an accumulator.
- (v) **Payload capacity:** The maximum weight the robot can carry is normally specified at low or normal speeds. It depends on the size and configuration of the robot. High payload capacity is a compromise with some other performance specifications, such as maximum speed, acceleration and accuracy. Very large robots can even carry payloads of several hundred kilograms.
- (vi) **Accuracy:** The Accuracy denotes how closely the end of the robot arm can be moved to a specific position. This is a function of several factors:
  - (a) The basic geometric configuration of the manipulator.
  - (b) The mathematical function used by the control system to convert position specifications from world co-ordinates to joint co-ordinates.
  - (c) The effects of the payload on deflections and distortions in the joints and arms, because of the robot's static and dynamic compliances.
  - (d) The effects of temperature on the joints and arms.
  - (e) Errors in the control system.
  - (f) The accuracy of the specification of the end position or objects to be reached.
  - (g) Degradation or drift in the performance of the actuators and sensors.
- (vii) **Resolution:** This may also be referred to as the precision of the robot. Resolution is the smallest increment of motion for which the robot can be controlled; it is normally dependent on the sensors used.
- (viii) **Repeatability:** Repeatability is the ability of the manipulator to repeatedly return to exactly the same position. It depends on the stability of the control system and is affected by temperature, load and joint clearances.
- (ix) **Reliability:** This is measured in terms of the average time between failures. Reliability depends on the speed and load during operation as well as on the quality of the robot design and control system. Industrial robots have usually high values of mean time between failures (MTBF).

#### 13.4.2 KEY FEATURE CAPABILITIES

In addition to the typical specifications, which define a robot's performance capabilities, a number of other features can also influence its performance. These features are more subjective and therefore difficult to quantify. They are:

- i. **Quality:** Generally, one can expect higher accuracy and reliability from robots that are built with better and more rugged electrical and mechanical components.
- ii. **Serviceability:** Many features can be added to the design of the robot to minimize both the frequency of failure and time it takes for repair. Such features include conservative designs for electrical and mechanical parts, modular design and extensive use of standard parts.
- iii. **Safety:** A wide variety of features are incorporated to prevent damage or injury during robot operation, including sensors, limit switches and end stops. The design of the work cell is as important as the selection of the robot.
- iv. **Modularity:** Adoption modular design technique enables for the manipulator to be reconfigured for different applications.
- v. **Dexterity:** This is the ability of the manipulator to perform delicate, precise, or complex tasks. This depends on the number of axes and the design of the gripper.

### 13.4.3 TECHNICAL SPECIFICATION OF A ROBOT

**Typical specifications of a robot are given below:**

No. of axes	6
Maximum reach	1 m
Payload	8 kgf
Repeatability	+ 0.025 mm
Joint speed	90 deg/sec
Waist rotation	290 deg
Shoulder rotation	300 deg
Elbow rotation	300 deg
Wrist pitch	+ 90 deg
Wrist roll	+ 180 deg
Drive	AC Servomotor
Mounting options	Pedestal, table top, floor, overhead, servo track

**Controller specifications:**

Processor	32 bit
Memory	10 MB
Communication	RS 232 Serial ports
User I/O	32 digital I/O
24 analog I/O	
Programming Language	AR-SMART, AR-BASIC

## 13.5 PROGRAMMING ROBOTS

The major advantage that robots have over fixed automation is their ability to be reprogrammed. They can perform complex tasks under the control of stored programs, which can be modified at will. In addition they can move in response to real time inputs from sensors. Programming is an important feature of robots, and it is also a significant component in their design and application. The process of robot programming involves “teaching” it the task to be performed, storing the program, executing the program, and debugging it. A number of different techniques and software approaches are used to program robots.

The kinematic analysis of a robot means the determination of position, velocity and acceleration of the various links of the robot. This can be of two types - direct kinematics and inverse kinematics. Direct kinematics involves determination of position of the end effectors for specified displacement of links. Inverse kinematics deals with the problem of the calculation of link movements to achieve a desired position of the end effectors. The inverse kinematics problem is important in most of robotic applications. The programming of the robot involves the coding of the data obtained from direct/inverse kinematic analysis so that the end effector of the robot is positioned suitably for the required applications.

The principal task of the robot program is to control the motions and actions of the manipulator. However, due to the inaccuracies and uncertainties involved in the positions and movements of robots, much of the programming involved deals with the detection and correction of errors. Programs must also be written to deal with both user and machines. The user may include professional programmers, as well as operators, maintenance personnel, and application engineers.

### 13.5.1 PROGRAMMING METHODS

The following methods are commonly used to program robots:

- i. **Guiding:** This is also known as the “Walk through” or “Playback” method. It involves manipulating the robot arm so that it can be moved manually through the intended motions while its link movements are being recorded by the control system. This is the simplest technique and does not require the operator to write any program code, but it is limited to relatively short and simple motions. With this method, the operator physically guides the robot through its movements. The stored “program” of robot motion can then be played back, during the actual performance of the task. It is also possible to edit this program to optimize it.
- ii. **Teach pendant:** This is also known as the “lead through” method. It uses a control panel, called a “teach pendant”, which has buttons or switches that control the motion of the robot. The operator or programmer can lead the manipulator through the task one step at a time, recording each incremental move along the way. Only the major points in the path of the robot’s movements are recorded,

so the intermediate points must be interpolated or calculated by the control system. The control system then generates a program for the complete path of the robot. Like the walk through method, this technique does not require code writing, but it can be used for more complex and precise tasks. It is often used for developing applications or training.

- iii. **Off-line programming:** This is the most common method of robot programming in which a high-level language is used to write a control program. This program describes all the movements and actions of each of the links of the robot. The program may involve many steps, requiring a large number of lines of program code. In addition, a great deal of computation is normally associated with the translation and generation of path of motion. This method of control is the most flexible and can also enable the robot to respond to signals from external sensors to modify its movements.
- iv. **On-line programming:** A variation of the above programming method is on-line programming. This requires the availability of a robot, but it also gives the programmer the ability to see the motions of the robot actually executing the program as it is being developed. In most cases, this approach is used either as a substitute for a teach pendant or to debug programs that have been written off-line.
- v. **Comparison of off-line and on-line programming:** On-line and off-line programming are used on different control levels of the robot cell. Off-line programming supports the integration of robots into a CIM system. It allows the manipulation of CAD system data to reduce the programming time by eliminating the interaction with the physical devices. The programming method, however, has difficulty in handling sensor information, and this obliges the programmer to use simulation, which allows modeling of the sensor input in critical situations and its interpretation. In general, an off-line programming system needs a software development environment to specify the application requirements, to analyze the tasks, and to decompose the global task to subtasks. Program test facilities are needed, as well. An on-line programming system provides tools for debugging and testing the program. Here the use of the physical robot system is required. An on-line language is more convenient to non-expert users.

### 13.5.2 ROBOT PROGRAMMING FUNCTIONS

A robot programming system involves major functions to make the execution of the actual task possible.

- (i) **Modeling the work space:** A significant part of specifying the robot's task is defining the positions of the elements and constraints involved in the application. When the task environment is not known precisely, the position of the robot must be specified relative to the objects. Position data may be obtained from several sources, such as robot sensors, geometric models, or external sensing systems.

- (ii) **Path generation:** The path of motion is normally specified by interpolating intermediate points from a sequence of motions and positions identified in the program. As mentioned earlier, the position specifications must be translated from world co-ordinates to joint co-ordinates, which the robot control system can understand. The type of path generated may not be coordinated between the joints. That is, each joint may move independent of the others. This will normally result in a non-uniform, curved path. If straight line motion is desired, the motions of the joints must be coordinated.
- (iii) **Sensing:** The use of sensors permits the robot to deal with uncertainties, which may include:
  - (a) The detection of errors.
  - (b) The identification of objects or positions, using a vision system.
  - (c) The initiation or termination of actions, using limit switches, proximity switches or feedback devices.

To use sensors, the robot control system must be able to connect and interpret sensory data from internal or external sources and generate control signals that will modify the actions of the manipulator. The data acquisition, computation, and output signal generation activities must be built into the control program. A sensor-based robot must have a program that allows it to choose between alternative actions on the basis of data from the sensors and its model of the environment.

- (iv) **Programming support:** Some of other functions that are necessary in a programming system for robots include:
  - (a) Editing tools for modifying programs.
  - (b) Debugging tools for finding problems during program development.
  - (c) Diagnostic tools for finding problems during operation.
  - (d) Simulators for trying out robot programs without actually operating the robot.
  - (e) Interfaces to controllers, peripheral equipment, and other computers.

### 13.5.3 THE ROBOT PROGRAMMING ENVIRONMENT

Today, robots are mainly used in high volume or medium lot production. Examples are spot welding of automotive chassis and component insertion in printed circuit boards. With the classical on-line programming methods a robot cannot be used for production during the programming. For this reason, off-line programming systems are needed as a linkage to production planning. Thus a higher flexibility and short manufacturing planning cycles can be realized.

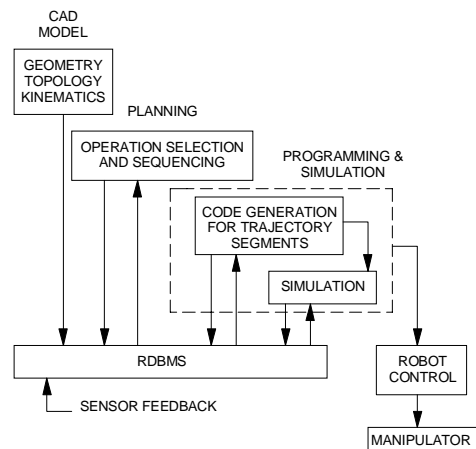
On-line programming languages for robots should support:

- (i) The specification of the program flow control.
- (ii) The capability of writing subroutines for exception handling.
- (iii) The sensor interaction and the rules for the sensor-guided path control.

In addition, they should emphasize the task to be performed rather than the specific robot motion, and they must offer an interface to off-line programming. Off-line programming languages for applications in CIM should have the following capabilities:

- (i) High level instructions for tactile sensors and vision sensors as well as user definable tasks and subroutines.
- (ii) Intelligent decision making capabilities allowing the robot to recover from an unexpected event.
- (iii) Use of CAD data of the object to manipulate or grip the object.

An advanced integrated off-line programming system includes a CAD modeler and may contain the components for a geometric modeler and graphic animation system and an off-line programming language and simulator, as well as an interface to the target robot system. Fig. 13.9 shows the structure of such a system.



**Fig. 13.9 Structure of an Off-line Programming System**

Programming of complex motion sequences requires the programmer to plan the motions in a three-dimensional workspace. Algorithms must therefore be provided to test the off-line control data generated for efficient work cycles, trajectories and collision avoidance. Suitable software tools for this purpose are simulation programs with graphical capabilities. These systems are based on three dimensional geometric and kinematic models. The dynamic models of robots require the formulation and solution of the motion equations in real time. A simulator consists of a package of emulated robot control functions.

The basic data generated by production planning, the geometric model to the working space, the robot model, and the product geometry are the input data of the simulation system. The objective of linking the CAD system to the robot planner is to increase the efficiency of the robot programming task by integration of design data and production planning data. In general, the following benefits can be expected with an off-line programming system:

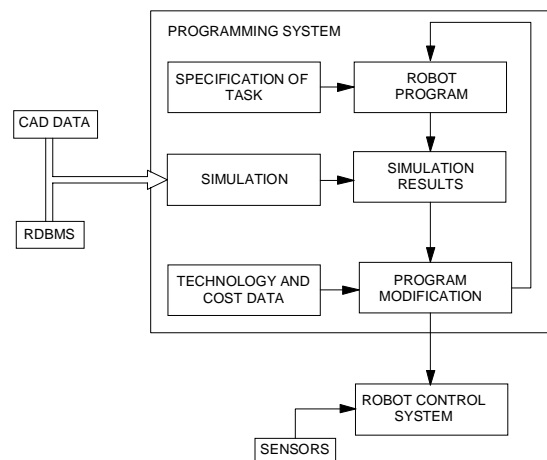


- (i) Elimination of downtime inherent to normal on-line programming.
- (ii) Availability of application programs for robots of various types.
- (iii) Less duplication in production planning and programming.
- (iv) An increase of the performance of the manufacturing system due to the generation of control data with the aid of the computer.

The geometric modeling usually is done with a 3D-CAD system with a solid modeler. Some of the available systems support modeling of kinematic chains and the definition of trajectory frames. For the direct generation of the position reference frames, geometric models of the initial, intermediate, and final product must exist. Collision check and optimization of the trajectory are done with the simulation system. This requires fast geometric reasoning.

### 13.5.4 PROGRAMMING ACTIVITIES

A block diagram of the off-line cell programming activities is shown in Fig. 13.10. Before the start of program development, the global planning of the task of the cell is necessary, referencing task-specific data and the cell description as input. The result is a sequence of complex operations of the cell represented in terms of a formal plan. In the next step the complex task of the cell is decomposed into several subtasks to be performed by the components of the cell. This requires dispatching of the subtasks to the cell devices, scheduling of the subtasks, and defining of synchronization rules between the subtasks. After the sequence of the subtasks and the task-related control structure has been described, the motion must be specified. Each subtask is related to trajectories, which must consider given geometric constraints, task frames, sensor data, and time intervals. The next step of the trajectory planning is to determine whether any collision may occur in the cell and to plan alternative trajectories for collision avoidance. In case of uncertainties, sensor subroutines may have to be activated to evaluate the situation and generate a corrective measure. Trajectory planning depends on the type and complexity of the robot control system.



**Fig. 13.10 Block Diagram for Off-line Programming**

### 13.5.5 PROGRAMMING LANGUAGE OF INDUSTRIAL ROBOTS

Presently, there are more than 300 robot programming languages. Programming languages can be classified as explicit or implicit. Explicit programming languages are based on such classical programming languages as Pascal, C, Modula-2, and Assembler. Object oriented languages like Small Talk or C++ are also applied in programming systems. An implicit robot programming system is based on a world model and knowledge about the task to be performed. A world model can be implemented with the help of the frame concept that originates from artificial intelligence. A frame is a logic structure suitable of processing facts and world data; it can be represented with the help of a relational database to obtain direct access to the stored information about the robot world. Relational database is an essential part of an implicit robot programming system. Two types of information are used to describe the world. One contains geometric and the other non-geometric parameters. The programmer must access both types and combine the retrieved information for the application at hand.

Relation between objects and attributes of the objects are parameters needed for implicit robot programming. Other data required are sensor parameters, descriptions of the robot (geometric, kinematic, and dynamic) and control data (trajectories).

### 13.5.6 BASIC TYPES OF ROBOT PROGRAMMING LANGUAGES

The robot programming languages can be classified according to the robot model, the type of control structures used for data, the type of motion specification, the sensors, the interfaces to external machines, and the peripheral used. The following types of robot programming languages are available:

- (i) Point-to-point motion languages
- (ii) Basic motion languages at the assembler level
- (iii) Non-structured high level programming languages
- (iv) Structured high level programming languages
- (v) Numerical control type programming languages
- (vi) Object-oriented languages
- (vii) Task-oriented languages

### 13.5.7 ON-LINE AND OFF-LINE PROGRAMMING LANGUAGES

The purpose of a robot control program is to yield the individual motions required of each of links. Robot programming is usually done with high-level languages that use a limited number of basic commands. They are normally executed by an interpreter rather than the compiler for ease of use. High-level interactive languages provide functions for data processing, computation, and sensing as well as manipulation. The commands used in a programming language are subroutines that are provided by the system which define frequently used functions. They may be used to control the actions of the robot, to perform computations, or to process data. Some of the basic types of commands are:

Motion and sensing functions (e.g., MOVE, MONITOR)

Computation functions (e.g., ADD, SORT)

Program-flow control functions (e.g., RETURN, BRANCH)

The most common command in most robot programs is to move the manipulator. The syntax for the move command is:

MOVE [<JOINTS><GOALS>]

E.g.: MOVE [<1, 3, 5><5, 10, 20>]

The first command means that joints 1, 3 and 5 are to be moved by 5, 10 and 20 units, respectively. There are also a number of frequently used functions that are not involved in the path itself (e.g., WAIT, CONTINUE, BRANCH, OUTPUT).

Many robot languages are now available. Each is unique in its design and capabilities. Some are more powerful and versatile than others. Some were developed by robot users, others by robot manufacturers. Some of the most widely used are:

VAL (Unimation)

AML (IBM)

HELP (General Electric)

RAIL (Automatrix)

AL (Stanford University)

MCL (McDonnell-Douglas)

RPS (SRI)

JARS (Jet Propulsion Laboratory)

AS (Kawasaki)

A program for loading a component in a CNC Chucker using a UMI RT100 Robot in teaches mode is given below:

```
0:    SEQUENCE -1 (Load the part from conveyor)
1     100% SPEED
2     UNFIX-GRIP
3     ABOVE-CONVEYOR
4     25% SPEED
5     ON-CONVEYOR-O
6     ON-CONVEYOR-C
7     FIX-GRIP
8     100% SPEED
9     ABOVE-CONVEYOR
10    PARK
```

```
11    OUT-LATHE
12    IN-LATHE
13    25% SPEED
14    IN-CHUCK-C
15    ;
0:    SEQUENCE-2 (RELEASE IN LATHE AND PARK)
1     100% SPEED
2     UNFIX-GRIP
3     IN-CHUCK-O
4     IN-LATHE
5     OUT-LATHE
6     PARK
7     ;
0:    SEQUENCE-3 (PARK TO LATHE)
1     100%SPEED
2     UNFIX-GRIP
3     OUT-LATHE
4     IN-LATHE
5     IN-CHUCK-O
6     IN-CHUCK-C
7     FIX-GRIP
8     ;
0:    SEQUENCE-10 (LATHE TO CONVEYOR)
1     100%SPEED
2     IN-LATHE
3     OUT-LATHE
4     PARK
5     FIX-GRIP
6     ABOVE-CONVEYOR
7     ON-CONVEYOR-C
8     UNFIX-GRIP
9     ON-CONVEYOR-O
10    ABOVE-CONVEYOR
11    PARK
12    ;
* 51: PARK
1:    100% SPEED
```

```
2:      FIX-GRIP
3:      -2265 2265 -380 0 0 0 1074 GOTO > POS
4:      ;
* 52:    ABOVE CONVEYOR
1:      -839 1295 -209 0 0 0 638 GOTO > POS
2:      ;
* 53:ON-CONVEYOR-C
1: -839 1295 -540 0 0 0 450 GOTO > POS
2: ;
* 54: OUT-LATHE
1: -1997 -34 -148 1258 -1258 -16 556 GOTO > POS
2: ;
* 55: IN-LATHE
1: -1223 -935 -108 1258 -1258 -73 638 GOTO > POS
2: ;
* 56: IN-CHUCK-C
1: -1223 -626 -117 1258 -1258 -73 638 GOTO > POS
2: ;
* 57: OUT-MILLER
1: 2047 -186 -18 0 -1 0 890 GOTO > POS
2: ;
* 58: IN-MILLER
1: 1314 547 -18 0 -1 0 890 GOTO > POS
2: ;
* 59: IN-VICE-C
1: 298 1563 -18 0 -1 0 118 GOTO > POS
2: ;
* 60: ON-CONVEYOR-O
1: -839 1295 -540 0 0 0 955 GOTO > POS
2: ;
* 61: IN-CHUCK-O
1: -1223 -649 -108 1258 -1258 -73 917 GOTO > POS3
2: ;
* 62: IN-VICE-O
1: 298 1563 -18 0 -1 844 60 GOTO > POS
2: ;
```

### 13.6 GEOMETRIC REQUIREMENTS FOR THE CAD/ROBOT LINKAGE

The off-line programming system provides the possibility of developing task-oriented and robot-independent user programs. That is, programs can be developed without having a specific robot in mind. When a task is decomposed into several subtasks, it must be possible to choose among different co-ordinate frames according to the specified task. For general-purpose applications a reference co-ordinate frame is used, since it allows the programmer to easily visualize the motion of the robot in a 3D space. The zero-reference points of the various co-ordinate frames are chosen freely by the programmer, who can then use location-independent information from the CAD database, which is accessed by any element of the manufacturing system.

To generate the user program, it is necessary to transform the geometric information of the different co-ordinates, into a common reference co-ordinate frame. This can be done automatically by the system. The required information to carry out the transformation is provided by the CAD system. To get an executable user program, a transformation from the Cartesian co-ordinate to the robot co-ordinate system must be performed. The transformation is necessary for a translation and rotation. The relative position and orientation between adjacent co-ordinate frames is calculated with a homogeneous transformation. With a freely selectable co-ordinate system, task-oriented programming is dependent of a special robot. The position of the robot in relation to the workspace must not be available during programming. However, the exact position data must be entered before the program is executed either by a simulator or the robot itself. Changes of the geometric relations between robot and its workspace can be simply correlated for. This programming technique is also useful for application to mobile robots.

In an integrated robot programming system, the information generated during the product design phase must be available from the CAD database. This includes geometry data, information on how to process and assemble the work pieces, and data on technological requirements for programming. For example, a surface representation of a car body must be carried out to define spot welding points and collision-free robot trajectories. For assemblies, a solid or surface representation is required to compute collision-free trajectories and control surfaces. Also required are task frames (e.g., grasp points, approach and return direction, and centre of gravity of the component). Standard interfaces for the exchange of geometric data are available with IGES or with STEP data exchange formats.

***Features of typical simulation software include:***

- > Tight integration between simulation systems and solid modeling packages
- > Real time 3D smooth shaded simulation
- > Automatic collision detection
- > Data conversion from CAD models
- > Extensive robot libraries

- > Input/output logic simulated between multiple devices
- > Automatic adjustment of robot work envelope for tool offsets and joint limits.
- > Real time tele-robotics control and simulation

### 13.7 SIMULATION

A graphical simulation system for the validation and specification of the robot program is an integral part of an advanced programming system. It must provide a library of emulated robots, transport devices, and end-effectors to build up a cell model quickly. Modeling capabilities should include modeling the robot's environment and the robot itself. The mathematics and geometric descriptions of the models depend on the desired accuracy of the simulation (2D-or 3D-models, wire frame, surface or solid representation). The graphic representation enables the operator to check the programmed operation sequence. Today, many PC workstations offer high resolution graphics based on the raster graphics technology.

Graphic standards like GKS or PHIGS facilitate the graphic animation of the simulated robot. For program alteration an interactive interface is necessary, which allows the use of a joystick, mouse or light pen. A simulation may be discrete / continuous. Discrete simulation supports programming of the overall control structure of a cell using predicate transitions. Continuous simulation is used for testing such details of the program as the robot motion, interaction with other components of the cell, and the dynamic behavior of the robot.

### 13.8 ADAPTIVE CONTROL

Adaptive control is the ability to modify a program in real time, based upon sensory data. Robots can make use of abilities such as orienting parts based on features, following a changed path, or recognizing work pieces. Adaptive control requires sensory input and the ability to respond to that input.

Adaptive control will greatly enhance role of the industrial robots in the computer integrated factory. The robot endowed with ability to adjust to its environment, reduces scrap and rework, and a robot equipped with adaptive control can perform quality - control functions integral with its tasks.

Adaptive control sensors for robots are found in the same general categories as the human senses: touch, sound, vision and process related sensors (functionally similar to taste and smell). Sensor input can be used at different levels in the robot hierarchy. Commonly, they are used for robot path or position alteration. Sensors may be used to adaptively control processes being performed by the robot. Sensor data may also send by the robot to other machines. The physical integration of sensors into the robot

structure has been dictated by the specific task to be performed and the properties of the sensors.

### 13.9 ROBOT OPERATION

Robots are used for several applications. Each application requires a certain mode of operations. These modes of operation can be classified into four types:

- i. **Pick-and-place:** As the name implies, this mode involves a very limited sequence of moves to a fixed position where it grasps a part ("pick"), then moves to another position where it "places" the part. Some applications may involve several move positions. The controls involved are generally the simplest. A non-servo control system, with either mechanical stops or pneumatic logic, is adequate. Because of the simplicity of the motion and the fixed positions involved, the pick-and-place mode can be accurate and capable of high speed. A typical application is placing the IC's on a printed circuit board.
- ii. **Point-to-point:** This is used for more complex movements where the arm is controlled in a series of steps that have been stored in memory. The programming is usually performed by the use of teach pendant. Although the movement is normally under servo control, there is no coordinated motion between the axes. Each axis operates at its maximum rate until it reaches the desired endpoint position. The intermediate path, velocity, and relative motion between axes are not controlled. This is adequate for many applications where only the activity at the endpoint positions is important. Applications like spot welding are examples of point to point operations.
- iii. **Continuous path:** This mode is required when the control of the manipulator's path is critical, such as in a spray-painting application. The robot's path is not determined by a series of pre-programmed points. The path and movement of each axis is stored during a walk through programming session. Although this creates a continuous path, it is not precise. All the movements of the operator intended or not, are recorded. A large amount of memory and a high-speed sampling system are needed to record all the path data.
- iv. **Controlled path:** Where the total control of the robot's motion as in an arc welding desired, a detailed control program and sophisticated servo-control system must be used. This provides coordinated control of all the axes in terms of their position, velocity, and acceleration. The program can optimize the movements of the manipulator to reduce cycle time, minimize forces, eliminate jerky motions, and improve precision. Sensors provide the necessary feedback to control the process. For example vision sensors provide feedback of progress of a robotic welding operation.



### 13.10 ENDS-OF-ARM-TOOLING

The robot control program must also control any operations involving the end-of-arm tooling or gripper. For simple one-step operations, a single output from an on-off switch may be all that is necessary to activate the gripper. For movements involving a sequence of several steps, multiple outputs may be required, including those from support fixtures and tools. In complex applications, the control program must integrate all the signals, which can influence the actions of the robot. They may include inputs from other machines to determine if they are ready to operate. They may also include signals, which notify the system that a part is present or that an operation was performed successfully.

### 13.11 CONTROL SYSTEM OPERATION

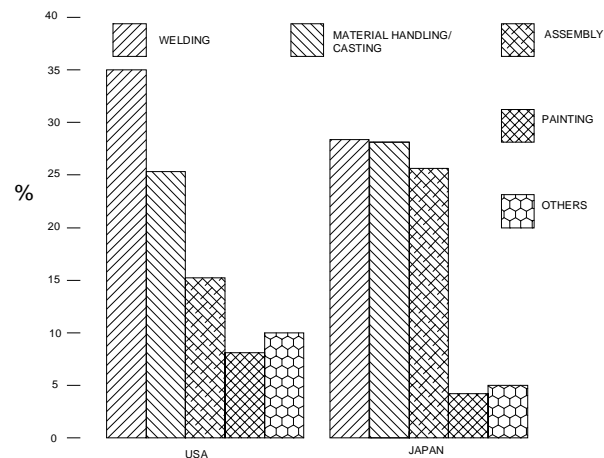
During the operation of a robot, the control system is very busy, even for relatively simple movements. A real-time servo control system executes a series of tasks at a fixed frequency, normally a high-speed sampling rate that has been pre-programmed into the control system. A typical sequence of events goes as follows:

- (i) Read input status (e.g., safety interlocks, power on)
- (ii) Execute program commands (e.g., MOVE)
- (iii) Check safety conditions
- (iv) Monitor sensor values
- (v) Interpret motion commands
- (vi) Output updated joint position goals
- (vii) Log and terminate processing

### 13.12 APPLICATIONS OF INDUSTRIAL ROBOTS

Robots are being used for a wide range of tasks in the industry (Fig. 13.11). A study of the application wise break-up of industrial robots in U.S. and Japan identifies major application areas to be handling, welding, surface coating, machining and assembly.

<b>Application</b>	<b>USA</b>	<b>JAPAN</b>
Welding	35%	28.5 %
Material	26%	27.5 %
Handling/Casting	8 %	9 %
Machine Loading	5 %	3.5 %
Painting Assembly	16 %	26 %
Others	10%	5.5 %



**Fig. 13.11 Applications of Industrial Robots**

### 13.12.1 MATERIALS HANDLING

Materials handling includes parts transfer from conveyors and palletization. Robots perform well in these applications as well as handling fragile components and heavy ones and parts that are very hot or very cold. The tasks can be simple or complex involving tracking in one or two axes or a moving conveyor. Some robots equipped with multiple tooling can handle more than one part at a time. A variety of end effectors have been used including mechanical grippers, magnets and vacuum cups.

### 13.12.2 MACHINE TENDING

From the very beginning machine tending (loading and unloading CNC machine tools, die casting machines, presses and forges) has been a popular application for robots. The reliability and steady pace of the robot can significantly increase machine tool utilization and productivity.

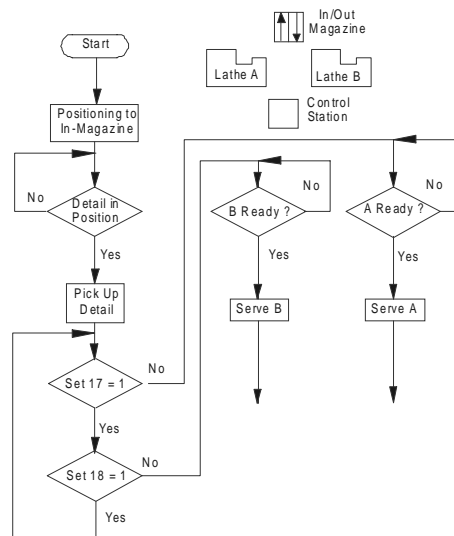
In many cases, because of long machining cycle times, a single robot services several machines. The machines may be grouped around the robot or the robot may move from machine to machine on a traversing base. Automatic gauging may be provided with the robot loading /unloading the gauge which might be interfaced with the machine control. Spindle orienting devices, chip blow - off systems, cycle timers and power actuated splash guards are machine modifications, which may be required when a robot is installed. In addition, machine may have to be relocated and part feeder/orienters must be provided. The applications can be quite complex and requires careful planning. Machine-mounted pick and place robots have been designed and installed on turning, boring, milling and grinding machines. They are popular due to low initial investment, simple maintenance, accurate loading cycle and high space efficiency.

Robotized serving of machine groups is economically rewarding even with short production series as the machine groups by reprogramming can be quickly adapted to a

wide range of other tasks. In serving a machine group, the robot functions as a materials handling device and ensures optimum utilization of different machines in the group.

A machine group is built in accordance with the requirement of a customer for manufacturing a certain range of product. The machines need to be modified for automatic operation and control from robot. The system usually includes measurement fixtures for palletizing, checking the parts at different stages, equipment for cleaning and deburring. To permit the machine group to work continuously, a supply and off-loading system like a conveyor is needed. The complete machine group is controlled by a robot system, which starts stops and checks all equipment in the group via inputs and outputs. Figure 13.12 shows a typical arrangement of a machine group being served by a robot.

Unloading die-casting machines and handling the castings and scrap are operations to which robots were first applied. These still remain as one of the most important robot application areas. The robots unload die casting machines, quench it, and place it on a trimming press and dispose of the spare and runners. The robot may also load inserts into the dies, spray die lubricant on to dies or ladle molten metal into the machine. A single robot may tend two machines. These applications provide excellent economic returns with short pay back periods by reducing labor cost, decreasing scrap, increasing die life and production rate of the machine. Robots associated with the plastic injection molding machines also perform similar tasks.



**Fig. 13.12 A Machine Group Served by a Robot**

Robots tending stamping and forming presses offer a means of complying with safety requirements and still have the flexibility to run batch operations. Robots are particularly useful for handling large/heavy stampings. Vacuum systems are often used to handle fragile and flexible parts. The major advantage of press loading relates to removal of the people from potentially hazardous, noisy and monotonous operations and the reduction in change over times for batch run parts.

Robot applications in forging include die forging, upset forging and roll forging. The robots may load furnaces, forging presses, headers and trim presses and lubricate dies. Special attention is taken to protect the robot from heat and shock loads. The applications offer significant benefits like reduction in labor cost and removal of human labor.

In comparison with traditional production methods, robotized machine group serving has the following advantages:

- Better utilization of both machines and robot
- Shorter throughput time
- Improved and more even product quality
- increased operational safety
- Lower personnel training costs
- Partly or completely unmanned production

### **13.12.3 WELDING**

Spot welding was the first major automobile application where robots were used extensively. This application is proven and so widespread that leading automobile manufacturers in U.S, Japan, Germany, Italy, U.K, and Sweden have fully automatic welding lines integrating number of robots, fixturing and transfer services. Robots are also used in Indian automobile industries. The robot's ability to carry out consistent placement of welds permit a reduction in number of spot welds required for the same net output.

#### **13.12.3.1 ARC Welding**

Arc welding is an area for extensive robotic application. Potential robot arc welding operations are not only two to three times faster than manual welding but also relieve workers from exposure to hazardous fumes, radiation and noise and from tasks, which call for high degree of concentration and skill. The advantages of the application of a robot to weld sheet metal components include improved and consistent quality of welds and removal of human operator from a tedious, unpleasant and potentially dangerous task. An example is the welding of header pipes in boilers.

#### **13.12.4 SURFACE COATING**

Surface coating operations with robots involve spray application of paint, stain, plastic powder, sound absorber or similar materials. The robots are normally servo controlled with six or seven degrees of freedom and are designed to be intrinsically safe for use in a volatile atmosphere. Cost savings in labor, consistent product quality, material savings, energy savings, reduced booth maintenance and relieving workers from exposure to toxic fumes are the advantages claimed for surface coating robotic installations.

#### **13.12.5 MACHINING**

Machining operations with industrial robots are relatively new area of application. Deburring of machined parts, grinding, polishing, removal of flash from parting lines of

forged/cast parts, drilling, routing and riveting of aircraft panels are some of the operations. Pneumatically or electrically driven tools are usually compliantly mounted on the robot. In some installations the robot handles the work piece against a fixed tool. Robotic machining has the potential to eliminate manual operations, which limits the production throughput and aims to eliminate costly tooling aids.

### 13.12.6 ASSEMBLY

Presently most assembly operations are effected manually and they represent a robotic application area of significant economic potential. A number of small servo controlled robots have been developed for assembly functions. Vision and tactile sensing capabilities are being developed to this new generation of robots. The inherent economic benefits, improved quality and increased productivity have encouraged research/development in this area.

Robots are widely used in automobile assembly. Some of such operations carried out by robots are:

Engine and power train assembly

- fixing flywheels, spring struts, front covers
- Front and rear axles
- Steering gear

Trim assembly

- Door liners
- Wind shield preparation and fitting

Final assembly

- Wheels
- Chassis module and body decking

### 13.12.7 INSPECTION

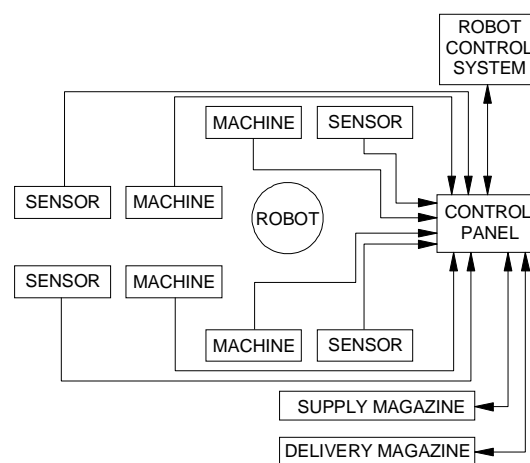
For inspection purposes, the robot may be used primarily as a handling device passively or it may handle the measuring device itself positioning the gauge in the programmed location relative to part inspected. Gauging devices can be either contact devices or lasers. Robotic inspection speeds up the process and assures high reliability of data as well.

## 13.13 THE INTEGRATION OF THE INDUSTRIAL ROBOT INTO A CIM SYSTEM

The block diagram of an industrial robotic cell is shown in Fig. 13.13. A robot can be programmed to serve a number of machines. This makes sense as otherwise the robot will be under utilized. In the figure the robot is shown to attend four machines. The work involved may be loading/unloading, deburring etc. Sensors attached to the

machines provide the necessary inputs and feedback to the robot. The work pieces are supplied in the pallets or magazines. Finished parts are loaded into appropriate magazines or pallets. The following issues require careful consideration in designing an efficient robotic work cell.

- The design of a product for robot-oriented manufacture.
- The planning for the installation of robot-based manufacturing system.
- The programming of the robot control and sensory operation supporting the robot's skill.



**Fig. 13.13 Block Diagram of an Industrial Robotic Cell**

### 13.14 PRESENTATION OF WORK TO ROBOTS

One of the important considerations in the robotic work cell design is the presentation of the work parts to the robot. Introducing robots involves not only replacing human beings by robots but also designing a suitable working environment so that robots will be able to perform satisfactorily. This usually requires design of a suitable fixture to present the work part to the robot. Many operations require several degrees of freedom of movement and some of these could be provided to the fixture. Often the fixture will be equally costly as the robot itself. Proper design of the system to present work part for operation by the end effector is very critical.

### 13.15 PRODUCT DESIGN FOR AUTOMATIC MANUFACTURE BY ROBOTS

Until very recently, the application of robot in various manufacturing areas was restricted to relatively simple tasks. The development of new robot applications, however, can be supported by the application of advanced hardware and software or by an improved product design that considers the restrictions of the robot. Innovations like hexapods have

been incorporated of late in the design of robots. Two research areas can thus be distinguished: the development of advanced assembly robots and the redesign of the product and its components for assembly by robots.

Both of these approaches are important, and they may complement each other. Till today, the first approach was the one mainly pursued by industry. However, the experience of companies indicates that much greater effort is required to design a product for assembly robots. Flexible assembly stations using robots require a standardization of the product or part of it and unique method for the description of the product assembly system.

### 13.16. MANUFACTURERS OF ROBOTS

There are a large number of robot manufacturers. Some of the well known manufacturers are listed below:

- Fanuc
- Kuka
- ABB
- Epson
- DENSO
- Hyundai
- Comau
- Nachi
- Motoman
- Adept
- ABB
- Seiko
- Kawasaki
- Staubli Unimation
- Mitsubishi

### QUESTIONS

1. What is the significant advantage of using a Robot in a computer integrated manufacturing system?
2. Describe the elements of a robotic system.
3. How do you justify the use of a robot?
4. How do you classify robots?
5. Differentiate between a SCARA and a gantry robot.
6. Define the work envelope of a robot. How does it differ from one type of robot to another?

7. What are the different types of drives used in robots?
8. What are the different types of control systems used in robots?
9. How do you specify a robot?
10. What are the different methods of programming of robots?
11. Discuss the basic types of robot programming languages.
12. How do you integrate CAD data with robot operation?
13. Briefly describe significant application areas of robots.
14. Discuss the importance of proper presentation of work parts to the robots.
15. Determine the effective work envelope of a robot from its specifications.



**This page  
intentionally left  
blank**

# COMPUTER AIDED QUALITY CONTROL

*Quality in manufacturing context can be defined as the degree to which a product or its components conform to certain standards that have been specified by the designer. The design standard generally relates to the materials, dimensions and tolerances, appearance, performance, reliability, and any other measurable characteristics of the product. This chapter deals with the integration of the quality control function in a CIM system. Using CIM, potential fit and function problems in the actions and interactions of the manufactured part and its tooling and assembly procedure can be analyzed successfully and remedial action taken earlier.*

## 14.1 INTRODUCTION

Getting anything right first time costs money. However, it also saves money. While the cost of getting it right increases, the cost of getting it wrong decreases. The important thing is to establish the level at which these curves cross and to achieve the optimum in terms of quality costs. However there is a further factor in the equation i.e. that of customer satisfaction. Quality control, which encompasses inspection, measurement and testing, is a vital part of any manufacturing activity and is applied to ensure consistently high quality in manufactured goods.

The quality control (QC) function has traditionally been performed using manual inspection methods and statistical sampling procedures. Manual inspection is generally a time consuming procedure, which involves precise, yet monotonous work. Parts may have to be removed from the vicinity of the production machines to a separate inspection area. This causes delays and often obstructs smooth flow of the components through different processes. Manufacturing schedules are also often upset because of this delay.

Inherent in the use of statistical sampling procedures is acknowledgement of the risk that some defective parts will slip through. Indeed, statistical quality control implies that a certain expected or average fraction defect rate will be generated during the production/inspection process. The nature of traditional statistical QC procedures is that something less than 100% good quality must be tolerated.

There is another aspect of statistical QC inspection process, which detracts it from its usefulness. It is often performed after the parts are already made. If the parts are defective they must be scrapped or reworked at an additional cost. There are several economic, social, and technological factors at work to modernize the quality control function. The economic factors include high cost of inspection and desire to eliminate inspection as a source of costly delay in manufacture. The social factors include the ever-increasing demand by customers for near perfection in the quality of manufactured items. The technical factors consist of several important advances, which have been made, in inspection automation.

Computer integrated manufacturing attempts to solve this problem in a different way. This concept is called total quality management.

## 14.2 TOTAL QUALITY MANAGEMENT (TQM)

In chapter 3, we discussed the application of concurrent engineering to product development. The total quality management is based on more or less the same philosophy. TQM is based on the assumption that quality cannot be “inspected into” a product; it must be “built into” it. That means any amount of inspection after the products or the components are manufactured will not help to improve the quality. One must look at the process itself to avoid production of poor quality products. To ensure this, consideration of the following aspects is necessary.

- i. **Quality of design:** Primary attribute of a good product is that the quality of its design must be superior. There are several factors, which influence the design quality.

**These include:**

- Choice of right materials
- Selection of appropriate raw material shapes
- Design involving minimum number of parts
- Use of standardization and variety reduction
- Reduction in the material removed during processing
- Economic use of materials
- Use of standard/bought out parts

A good product can be evolved if the design is analyzed using “Failure Modes, Effects and Criticality Analysis (FMECA)” as well as “Design for Manufacture and Assembly (DFMA)” techniques. Softwares are now available to carry out this task. The use of FMECA and DFMA techniques will ensure that all the weak aspects of design, which affect product quality and make manufacturing difficult, can be identified and rectified before the drawings are released for manufacture.

- ii. **Selection of appropriate process and equipment:** Proper design of the manufacturing technique plays an important role in the quality of the product.

CIM lays great emphasis on manufacturing technology development for new product development, which often requires new manufacturing techniques or refinement of existing technique. However, choice of appropriate technique of manufacture is a key issue influencing the quality of the product.

- iii. **Choice of equipment:** Choice of process equipment is another vital factor. The equipment must have the capability to produce parts of requisite quality without extra attention on the part of the operator. Since CIM uses equipment like computerized machines and handling equipment with integrated process monitoring and control, this aspect has been well taken care of.
- iv. **Training of personnel:** One of the important aspects of quality production is that the personnel involved in the production must be properly and adequately trained to carry out their task. They ought to know how to produce the product, with the required quality. They should be well aware of the quality requirements. The axiom “doing it right, the first time, every time” is significant in this context.

Today, every manufacturer is keen to obtain ISO-9000 certification. Implementation of CIM automatically takes care of many documentation and communication requirements of ISO-9000, right from product design to testing and shipping, covering the entire gamut of manufacture.

### 14.3 QC AND CIM

A wide range of computer-based instrumentation is being used for quality control. In particular the increased sophistication of sensors and transducers, which are part of CIM, is making it easier to carry out pre-process, in-process, and post-process inspection. Inspection and testing are meant to reduce wastage and make maximum use of resources.

The incorporation of digital techniques in manufacturing systems and the use of computers and microprocessors for controlling manufacturing processes have resulted in the introduction of several types of inspection techniques. In modern manufacturing systems, inspection is no longer considered as an appraisal oriented process (ACCEPTED/REJECTED) but as prevention oriented process. At present, inspection with the use of computers has acquired a status of its own known as COMPUTER AIDED INSPECTION (CAI) and is an integral part of Computer Integrated Manufacturing.

The present day concern in any manufacturing shop is to ensure that every component and the end product produced should meet an established and well-defined quality levels. It should also to aim at a cost effective inspection system. This calls for an inspection system, which should be able to track the production process, and which has the potential for providing information to implement corrective action before the process goes out of control. This can be carried out by both contact type and non-contact type inspection which can collect the data not only to qualify or classify a component but also to correct the manufacturing process that may cause undesirable deviation. The additional advantages of non-contact type systems are the instant data collection and data evaluation with less

human effort. In addition to this, integration of the latest measuring systems with the manufacturing activities and use of computer for controlling, directing, machining, inspecting etc., result in the total integration of manufacturing.

#### 14.4 INSPECTION AND TESTING

Inspection is normally used to examine whether a product conforms to the design standards specified for it. For a mechanical component, this would be probably concerned with the dimensions, surface texture and tolerances specified for the part. Non-conforming goods result in scrap, rework, and the loss of customer goodwill.

***The common situations that warrant inspection are:***

- Incoming materials (raw materials, standard items, subcontracted parts)
- Stage inspection during manufacturing (e.g., when the parts are moved from one production section to another)
- At the completion of processing of the parts
- Before shipping the final assembled product to the customer.

Whereas inspection is a regular activity in production, testing is a significant stage of work in product development to prove the capability of the product. Testing is normally associated with the functional aspect of item, and is often directed at the final product rather than its components. Testing consists of the appraisal of the performance of the final product under actual or simulated conditions. If the product successfully passes the tests, it is deemed suitable for use. Testing ascertains the quality of performance of the product.

***Various categories of tests used for final product evaluation are listed below:***

- Functional tests under normal or simulated operating conditions
- Fatigue or wear tests to determine the product's life function until failure
- Overload tests to determine the level of safety factor built into the product
- Environmental testing to determine how well the product will perform under different environments (e.g. humidity, temperature, vibration).

Another test that is often resorted to is destructive testing. This is a procedure that results in destruction of the item in order to measure the property of interest. A common example is the tensile test on a metal specimen to determine the metal's strength and ductility properties. Destructive testing is often employed as an inspection procedure, because it is often applied to raw materials, partially processed materials and component parts. It can also be applied to the final product. However, destructive test for final products is very expensive and would be done on a very limited sampling basis. Tests at the prototype stage yield valuable information for product improvement.

### 14.5 STATISTICAL PROCESS CONTROL (SPC)

A controlled production process is one in which only random causes influence quality variation. It means that the process parameters which affect the variability of the process is well under control and the process monitoring mechanism can detect any significant change in the process. Statistical process control (SPC) is widely employed in CIM to exercise process control. SPC uses X charts, R charts and SIGMA charts to monitor process variability. Measuring instruments are directly linked to microprocessor-based equipment to process the data and display results.

Several SPC instruments are now available in the market. These instruments include hand held instruments as well as PC based systems. Control charts, Pareto charts, histograms and full SPC analysis can be done using these equipments. Data entry to an instrument is either manually, via the keyboard, or directly from a gauge.

### 14.6 OBJECTIVES OF CAQC

***The objectives of computer-aided quality control are to:***

- i. Improve product quality
- ii. Increase productivity in the inspection process
- iii. Increase productivity
- iv. Reduce lead-time
- v. Reduce wastage due to scrap/rework

The strategy for achieving these objectives is basically to automate the inspection process through the application of computers combined with sensor technology. Where technically possible and economically feasible, inspection should be done on a 100% basis rather sampling.

### 14.7 ROLE OF COMPUTER IN QC

Computer-aided inspection (CAI) and computer aided testing (CAT) are the two major segments of computer-aided quality control. Whereas these activities have been traditionally performed manually (with the help of gauges, measuring devices and testing apparatus), CAI and CAT are performed automatically using computer and sensor technology. Today, CAI and CAT can be well integrated into the overall CIM system.

The implications of the use of computer-aided quality control are important. The automated methods of CAQC will result in significant improvements in product quality. The following list summarizes the important benefits of CAQC.

- i. With Computer aided inspection and computer aided testing inspection and testing will typically be done on a 100% basis rather by the sampling procedures

- normally used in traditional QC. This eliminates any problem in assembly later and therefore is important in CIM.
- ii. Inspection is integrated into the manufacturing process. This will help to reduce the lead-time to complete the parts.
  - iii. The use of non-contact sensors is recommended for computer aided inspection and CIM. With contact inspection devices, the part must be stopped and often repositioned to allow the inspection device to be applied properly. These activities take time. With non-contact sensing devices the parts can be inspected while in operation. The inspection can thus be completed in a fraction of a second.
  - iv. The on-line non-contact sensors are useful as the feedback element of adaptive control systems. These systems will be capable of making adjustments to the process variables based on analysis of the data including trend analysis. An example of the application of trend analysis can be found in the compensation of gradual wear of cutting tool in a machining operation. This would not only help to identify out-of-tolerance conditions but also to take corrective action. By regulating the process in this manner, parts will be made much closer to the desired nominal dimension rather than merely within tolerance. This will help to reduce scrap losses and improve product quality.
  - v. Sensor technology will not be the only manifestation of automation in CAQC. Intelligent robots fitted with computer vision and other sensors, as an integral part of completely automated test cells is also a feature of CIM.
  - vi. An important feature of QC in a CIM environment is that the CAD/CAM database will be used to develop inspection plan.

As mentioned earlier inspection can be either contact or non-contact type. The contact method usually involves the use of coordinate measuring machines (CMM).

## 14.8 COORDINATE MEASURING MACHINE

The coordinate measuring machine (CMM) is the most prominent example of the equipment used for contact inspection of parts. When used for CIM these machines are controlled by CNC. A typical three-dimensional measuring machine consists of a table, which holds the part in a fixed, position, and movable head, which holds a sensing, probe. The probe can be moved in three directions corresponding to the X, Y and Z Coordinates. For manual operation, the control unit is provided with joysticks, or other devices which drive X, Y and Z servo motors (AC/DC).

During operation, the probe is brought into contact with the part surface to be measured and the three co-ordinate positions are indicated to a high level of accuracy. Typical accuracies of these machines are in the neighborhood of + 0.004 mm with a resolution of 0.001 mm. The measuring accuracy of a typical CMM is quoted  $2.6 + L/300$  micrometers, where L is the measured length in mm.

A typical CNC CMM is shown in Fig. 14.1.

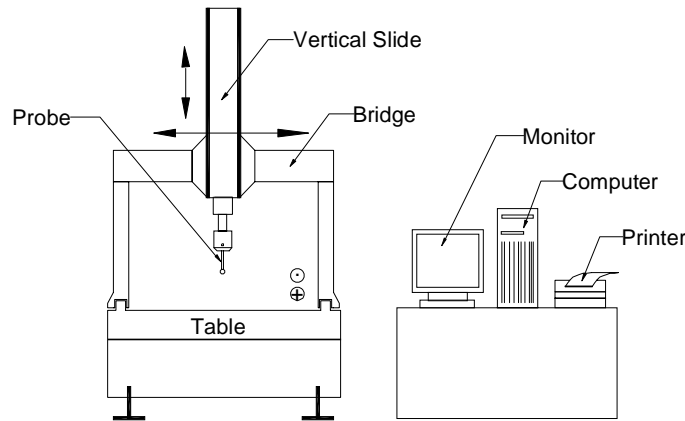


Fig. 14.1 CNC CMM

**The major features of a CMM are:**

- (i) **Stationary granite measuring table:** Granite table provides a stable reference plane for locating parts to be measured. It is provided with a grid of threaded holes defining clamping locations and facilitating part mounting. As the table has a high load carrying capacity and is accessible from three sides, it can be easily integrated into the material flow system of CIM.
- (ii) **Length measuring system:** A 3-axis CMM is provided with digital incremental length measuring system for each axis.
- (iii) **Air bearings:** The bridge, cross beam and spindle of the CMM are supported on air bearings with high rigidity. They are designed insensitive to vibrations.
- (iv) **Control unit:** The control unit allows manual measurement and self teach programming in addition to CNC operation. The control unit is microprocessor controlled. Usually a joystick is provided to activate the drive for manual measurement.

CNC Measuring Centres are provided with dynamic probe heads and a probe changing system, which can be operated manually or automatically.

- (v) **Software:** The CMM, the computer and the software together represent one system whose efficiency and cost effectiveness depend to a large extent on the software.

**The features of CMM software will include:**

- Measurement of diameter, centre distances, lengths, geometrical and form errors in prismatic components etc.



- On-line statistics for statistical information in a batch.
- Parameter programming to minimize CNC programming time of similar parts.
- Measurement of plane and spatial curves.
- Data communications.
- Digital input and output commands for process integration.
- Programs for the measurement of spur, helical, bevel and hypoid gears.
- Interface to CAD software.

Typical software may also provide a generalized method for reverse engineering complex shaped objects. The component is digitized, taking a dense set of points, using a CNC CMM. The digitized data is then converted into a computer model, which describes the true surface of the component, with allowance for the digitizing probe diameter. The model may then be expanded, offset or mirrored to an allowance for the manufacturing process.

Recent advances in CMM technology are based largely on greater intelligence features provided by the computer software. These advances include the capability for automatic work part alignment on the table, interactive programming of the CMM for inspection personnel who are not experienced in the use of computers. Besides this, the software has the capability to orient the coordinate system as required (between polar and Cartesian coordinate systems). Similarly translation of origin can be effected as desired.

Savings in inspection time by using CMM are significant. Typically between 5 and 10% of the time is required on a CMM compared to traditional manual inspection methods. Other advantages include consistency in the inspection process from one part to the next, which cannot be matched by manual inspection, and reductions in production delays to get approval of the first workpiece in a batch.

#### **14.8.1 ADVANTAGES OF CNC OPERATION OF CMM**

CNC operation increases cost effectiveness through the following advantages:

- i. Shorter measuring times
- ii. Higher throughput rates
- iii. Better repeatability
- iv. Economical even for small batches
- v. Simple operation
- vi. Unmanned second and third shift inspection of parts if parts are loaded automatically.

#### **14.9 NON-CONTACT INSPECTION METHODS**

The field of non-contact inspection, in particular optical inspection is composed of the following basic areas:

- i. Inspection of part dimensions.
- ii. Inspection of surface defects.
- iii. Inspection of completed or semi-completed parts.

***The main advantages of non-contact inspection are:***

- i. It eliminates the need to reposition the workpiece.
- ii. Non-contact inspection is faster than contact inspection.
- iii. There is no mechanical wear encountered in the contact inspection probe.
- iv. The possibility of damage to the surface of a part due to measuring pressure is eliminated.

Some of the examples of non-contact inspection are laser interferometer measuring system, laser telemetric measuring system, machine vision system and optical gauging. These are discussed below.

#### **14.9.1 LASER INTERFEROMETER MEASURING SYSTEM**

Presently lasers are used as length measuring devices. They are commonly used for positional accuracy measurements. They are also used as length measuring machines of high accuracy (accuracy of the order of 0.01 micrometer). The feed back of this can be used for positioning of the machine and also for computation of measurements.

Nowadays it has become a common practice to use laser-measuring system for the calibration of CNC machines. Using laser-measuring system the measurements performed are reliable, accurate and faster compared to conventional methods. The laser interferometer can be directly interfaced with a computer. This makes it easy for the operator to evaluate the results as per the evaluation procedures mentioned in various standards like AMT, AFNOR, VDI, MTTA, and JIS etc. Using different attachments laser interferometer is also used for other measurements like straightness, flatness, squareness, velocity, pitch, yaw etc.

#### **14.9.2 LASER TELEMETRIC MEASURING SYSTEMS**

This is a high speed gauging system providing accuracy and repeatability of a contact type gauge with versatility of a non-contact type of gauge. The principle is explained below:

A thin band of laser beam projects from a transmitter to receiver. When an object is placed across the beam, the object casts a shadow. The signal from light entering the receiver is used by the microprocessor to detect the shadow and to calculate the dimension represented by the distance between the edges of the shadow.

***The system consists of three modules:***

- i. Transmitter module
- ii. Receiver module
- iii. Processor electronics

The transmitter module contains a low power He-Ne gas laser and its power supply, a specially designed collimating lens, a synchronous motor, multi-faced reflector prism, a synchronous pulse detector and protective window. This produces a collimated parallel scanning laser beam moving at a high and constant speed. The scanning beam appears as a line of red light. The receiver module collects and photo electrically senses the laser light transmitted past the object being measured. The processor electronics takes the receiver signals and converts them to digital signal and displays the dimensions being gauged.

The information thus collected is processed not only to qualify or classify a part but also can be used to correct the manufacturing process that might have caused the undesirable deviation. This is done automatically without touching the part and without the need for human intervention. The microprocessor actuates precise computer control of continuously manufactured parts. The prompting formats guide the operator regarding the gauge setting. The operational procedures notify the operator in case any error occurs in the system by displaying error message on the CRT terminal. It also keeps the operator informed about the product in the production process, displays, prints out and records the complete measured and analyzed results.

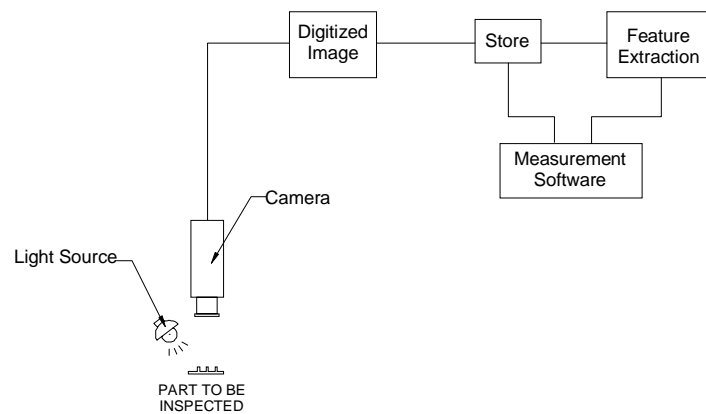
Laser telemetric measuring systems give out a number of signal outputs and processing options to make the dimensional measurement more useful in production environment. Examples are listed below:

- i. A high/low limit alarm option, which activates lights and connector panel, output when the tolerance limits are exceeded.
- ii. A process control option, which makes it possible to provide a closed loop control of the diameter of a continuously processed product. The chart recorder and instrumentation interface provide both an analog output for plotting deviation and a RS-232C for digital transmission of other instruments and controls.

### **14.9.3 VISION SYSTEM**

A vision system can be defined as a system for automatic acquisition and analysis of images to obtain desired data for interpreting or controlling an activity. In a broader sense, the term is applied to a wide range of non-contact electro-optical sensing techniques from simple triangulation and profiling to a 3D object recognition technique. These are based on sophisticated computerized image analysis routines. The applications range from relatively simple detection and measuring tasks to full-blown robot control, which include quality assurance, sorting, material handling and process control, robot guidance, calibration and testing, machine monitoring and safety.

The schematic diagram of a typical vision system is shown in Fig 14.2. This system involves image acquisition, image processing or image analysis and interpretation. Acquisition requires appropriate lighting, the use of electronic camera and means of storing a digital representation of the image. Processing involves manipulating the digital image to simplify and reduce number of data points that must be handled by subsequent analytical routines used to interpret the data. Computers with suitable softwares are used for this purpose.



**Fig. 14.2 Typical Vision System**

By using the vision systems measurements can be carried out at any angle along all the three reference axes  $X$ ,  $Y$  and  $Z$  without contacting the part. The measured values of the component parameters are then compared with the specified tolerances, which are stored in the memory of the computer.

The measured values, the specified values with the deviation and an indicating on whether the part is passed or not passed are displayed on the VDU. Using a sorting system it is also possible to sort the parts based on these results.

Computer vision systems offer several advantages like reduction of tooling and fixture costs, elimination of need for precise part location for handling by robots and integrated automation of dimensional verification and defect detection.

#### 14.9.4 NON-CONTACT CNC CMM

The non-contact CNC CMM inspects a part by observing it with a video camera, analyzing the image and outputting the results. The construction of this CMM is similar to that of a conventional CMM. These are particularly useful to measure the following workpieces, which are difficult to measure with contact method:

- Printed circuit boards.
- Pins and connectors.
- Injection molded plastic items.
- Pressed parts.
- IC package.
- Ceramic parts.
- Photoelectric parts.
- Etched parts.

Some non-contact CMM's operate using laser digitization technique. These are particularly suitable for measurement of complex 3-D surfaces. This equipment makes product data generation for reverse engineering an easy task.

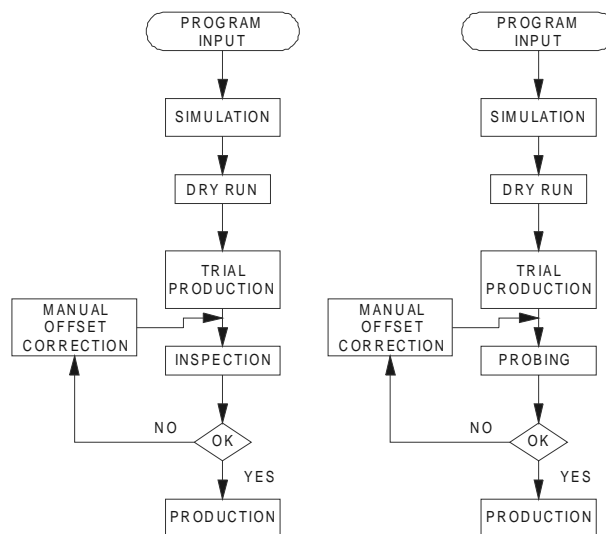
## 14.10 POST PROCESS METROLOGY

The process of measuring the workpieces during machining and automatically updating the machine tool offsets in the control system to maintain the dimensional quality of the workpiece machined without any manual intervention is called post process metrology. Post process gauging in particular embraces a variety of cost saving and quality control techniques.

The advantages of post-process gauging can be seen from Fig. 14.3. which shows the conventional use of CNC machines with a long set-up time and first off approval cycle delaying the start of full speed production. The post process metrology set-up can reduce the cost and time of production. In this case the set up time and first off inspection time constitute the total time for trial production. Also the faults can be rapidly detected and corrected during the process itself.

One of the common methods of post process metrology is by using a touch trigger probe. This can be incorporated into the machining centre or a CNC lathe to perform the gauging operation on workpieces. These are omni-directional probes with inductive, optical or infrared transmission, which incorporates a sensitive electrical contact, and deflect from its home position when the pressure is applied.

At the start of the cycle, the probe is placed in the tool magazine of the machine tool. The probe movement will be programmed as per the gauging of the component for its dimensional parameters. As per the programmed sequence the probe takes the position in the spindle in the place of cutter and moves in the required sequence to gauge the component.



**Fig. 14.3 Production of Parts with and without Post Process Metrology**

The signals from the probe will be transmitted to the control system to initiate the corrective action. After incorporating the correction through tool offset, the full speed production will be started.

***The general applications of probe systems are given below:***

- Inspection
- Component verification
- In-cycle gauging
- Digitizing
- Tool setting
- Job set up
- Tool breakage detection

The data from the probe systems can be communicated to the machine control unit in three ways:

- a. Inductive transmission
- b. Hard-wired transmission
- c. Optical transmission

The actual gauging cycle, contained in the part programme, is brought into action between cutting cycles. Based on the information received from the measuring system corrective action through appropriate offset values will be incorporated in the system to machine the component to the required size.

#### **14.11 COMPUTER AIDED INSPECTION USING ROBOTS**

Robots can be used to carry out inspection or testing operations for mechanical dimensions and other physical characteristics and product performance. Generally robot must work with other pieces of equipment in order to perform the operations. Examples include machine vision systems, robot manipulated inspection and/or testing equipment.

Checking robot, programmable robot, and co-ordinate robot are some of the titles given to multi-axis measuring machines aimed at high-speed measurement. These machines automatically perform all the basic routines of a CNC co-ordinate measuring machine but at a faster rate than that of a CMM. These machines are designed to be used in environments such as shop floor. They are not as accurate as precision CMM's but they can check up to accuracies of 5 micrometres which is often sufficient for many applications. However, quality levels can be improved by increasing the number of inspections. By using robots the dimensional drifts can be accurately and quickly detected

and the appropriate process action can be taken. One example is, segregating the components according to the tolerance specifications.

Using the modern touch trigger probe, a co-ordinate robot or a pair of robots can take successive readings at high speed and evaluate the results using a computer graphics based real time statistical analysis system. This gives high-speed data processing of measured information and can provide early warning of rejection. The computer also monitors the geometry and wear of the tools, which produce the component. After the measurement, if the component is not acceptable it is placed on a conveyor where it slides under gravity into REJECT bin.

## **14.12 INTEGRATED COMPUTER AIDED INSPECTION SYSTEMS**

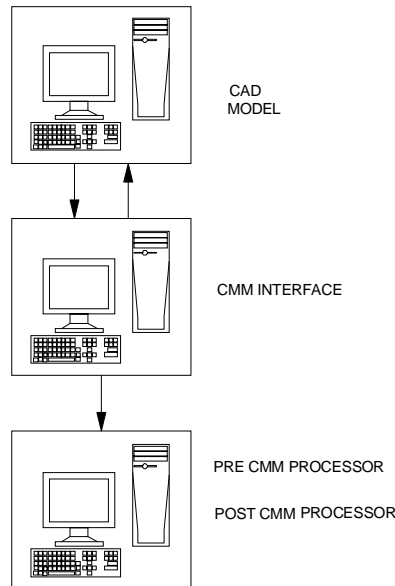
Automation in industries is intended to provide a batch oriented manufacturing. The integration of the activities starting from design to the part coming out of the factory leads to total automation. This closes the loop in a computer integrated manufacturing system. Some of the integrated systems are available in different configurations, examples being integrated CAD/CAM/CAI Systems with robots etc. Some of these are discussed in the following sections:

### **14.12.1 INTEGRATION OF CAD/CAM WITH INSPECTION SYSTEM**

CAD/CAM systems are seen as a natural adjunct to automatic gauging wherein a product is designed, manufactured and inspected in one automatic process. There is a strong trend in the direction of a closed loop, fully adaptive manufacturing system.

One of the critical factors in manufacturing quality assurance is to ensure that every part coming off the production line is within design tolerance. The successful factory constantly monitors quality at each step of design and manufacturing process. In the shop, the coordinate measuring machine assists in this quality assurance function. The productivity of the coordinate measuring machine can be improved by interfacing with a CAD/CAM system. Interfacing with the CAD/CAM database, the operator can use the off-line programming capabilities of the CMM interface to process the input values for the part geometry being measured. This eliminates the laborious manual data entry techniques and reduces preparation time and increases availability of CMM for inspection.

The CAD/CAM-CMM interface helps the programming efforts in the quality assurance office where quick response to engineering changes can be made and current data to the CMM can be provided. Generally the CAD/CAM-CMM interface consists of a number of modules as shown in Fig. 14.4.



**Fig. 14.4 CAD/CAM-CMM Interface**

- i. **CMM-Interface:** This interface allows interacting with the CAD/CAM database to generate a source file that can be converted to a CMM control data file. During source file creation, CMM probe path motions are simulated and displayed on the CAD/CAM workstation for visual verification.  
A set of CMM command statements allow the CMM Interface to take advantage of most of the CMM's functional capabilities. These command statements include setup, part datum control, feature construction, geometric relations, tolerancing, output control and feature measurements like measurements of lines, points, arcs/circles, splines, conics, planes, analytic surfaces, tabulated cylinders and sculptured surfaces.
- ii. **Pre-CMM processor:** The pre-CMM processor converts the language source file generated by CMM Interface into the language of the specified Coordinate Measuring Machine. The output is a file stored in the CAD/CAM host operating system level. Whenever, a statement is encountered which is not supported by the selected CMM, the pre-CMM processor will display a warning message. This allows generation of multiple CMM control data files from one source file.
- iii. **Post-CMM processor:** The post-CMM processor creates wire frame surface model from the CMM-ASCII output file. Comments are inserted into the ASCII-CMM output file to control the creation of the CAD/CAM entities, which include points, lines, arcs/circles, conics, splines and analytic surfaces.

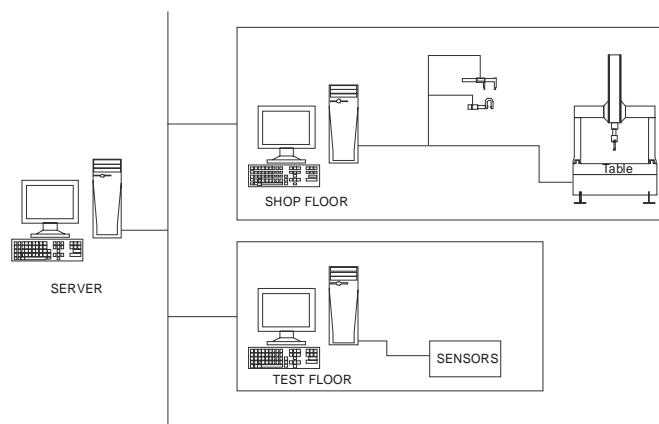


### 14.13 FLEXIBLE INSPECTION SYSTEM (FIS)

Fig. 14.5 shows the block diagram of a comprehensive flexible inspection system. This system has been developed with the intention of the integration of the inspection done at several places in a factory.

FIS also helps to close the loop between the design intent and product performance and to improve inspection technology and thereby increasing the productivity. A powerful computer serves as a real time processor to handle part dimensional data and as a multi-programming system to perform such tasks as manufacturing process control. The terminal provides interactive communication with personal computers where the programmes are stored. The typical digital input devices used with this system are CMM's, microprocessor based gauges and other inspection devices. The data from CMM's and other terminals are fed into the main computer for analysis and feed back control. The quality control data and inspection data from each station are fed through the terminals to the main computer. This type of communication could be from more than one factory location, in which case the data will be communicated through telephone lines. Even data from acceptance tests on new machine tool building plant are fed to this computer for analysis. Machine capability studies are also carried out by taking large samples (30-50 pieces) from a particular machine. Final product audit and inspection are also carried out with the help of CMM's and other suitable inspection aids with the capability of directly feeding the data to the computer. TESA, CARL JOHANSSON and other manufacturers of metrology equipment supply such integrated systems.

Flexible inspection system involves more than one inspection station. The objective of the flexible inspection system is to have an off-line multi-station automated dimensional verification system to increase the production rate, lessen the inspection time and to maintain the inspection accuracy and data processing integrity. The important features of FIS include dynamic statistical sampling programs, which provide automatic adjustment to modify the number of parts, and part features to be inspected based on the inspection history.



**Fig. 14.5 Flexible Inspection System**

**QUESTIONS**

1. What is the significance of quality control in CIM?
2. Define total quality management and explain its relevance to CIM.
3. What are the objectives of computer aided quality control?
4. Discuss the important benefits of computer-aided quality control.
5. Explain the method of part inspection using a CMM.
6. What are the important features available in CMM software?
7. Discuss major non-contact inspection methods.
8. What is the working principle of computer vision systems?
9. How is post-process metrology incorporated in CNC Machines?
10. Describe the features of a flexible inspection system.
11. Discuss the integration of CAD database and CMM operation.

**This page  
intentionally left  
blank**

# FUNDAMENTALS OF NETWORKING

## CHAPTER

# 15

*Communication is the nervous system of CIM and thus is an integral part of CIM. The developments in communication engineering have made implementation of CIM easier than before. This chapter presents a brief overview of fundamentals of networking of computers and introduces the concepts of enterprise wide networking. The potential of Internet and workflow automation software in the implementation of CIM is also emphasized.*

### 15.1 INTRODUCTION

Data is defined as the raw, unorganized information that is available on each component of a CIM system like a PC, Robot, and Workstation or CNC machine. Normally, each component wants access to all the necessary data to make decisions. This means each component in a CIM system, can take advantage of all the available information to achieve higher reliability, more optimal processing or manufacturing and higher throughput. Networks allow channels of communications to exist among various sections of a manufacturing system. Real-time modifications to business plans can be effected via communications through the network. Networks are essential to move information faster across various users or various segments of CIM. For example, while the design is being completed, if the manufacturing engineer has access to the design data of the component, the engineer can plan fixture design and start creating the program for manufacture. The process-planning engineer can select a suitable machine tool to machine the component. These are typical cases where time can be saved.

Networks are today integral parts of CIM systems, which have made data sharing easy, peripheral changing or interfacing easy and information sharing possible.

### 15.2 PRINCIPLES OF NETWORKING

Advances in technology have been adding more processing power into smaller computers. The trend has been to move away from massive, centralized computers, which handle every task to networks of smaller desktop computers, each closely tailored to a particular application.

From the manufacturing standpoint, this eliminates the possibility of shutting down the entire plant if a large central computer fails. It is easier to replace a defective PC. More desktop computers can be added to the network depending on the need. Thus, the network is scalable. Networking also allows incremental growth of the overall system with minimal investment and disruption.

Networking is a convenient technique for tying together the various “islands of automation” which were discussed in Chapter 1 and in the process makes integration possible through high-speed data exchange between different automated segments.

Networking of computers was initially adopted successfully by service sectors like banking, airline and train reservation etc. and later was introduced in manufacturing industries. Today, many designs involve collaborative efforts of hundreds of engineers. Networked systems facilitate quick information exchange and effectively cut down development lead-time. Some examples are:

- (i) Design and development of VLSI and UVLSI chips like microprocessors.
- (ii) Design and manufacture of aircrafts and automobiles.

Communication networks can be classified into four categories depending upon the physical separation of the communicating devices:

- (i) Miniature (< 50 m): Such networks are concerned with the interconnection of multiple computational elements.
- (ii) Small (< 500 m): These are concerned with the interconnection of multiple computational units.
- (iii) Medium (< 1 km usually): These networks are concerned with the interconnection of multiple computational units (office workstations, CAD systems, shop floor computers and data collection terminals, CNC systems, Robots etc.). These are connected through a Local Area Network (LAN), or Intranet. LAN may cover distances more than one 1 km too.
- (iv) Large (> 1 km): Large networks involve connection of remote mainframes, networking of a minicomputer system to a remote mainframe or terminals etc. It can be citywide (Metropolitan Area Network-MAN) or countrywide or Worldwide-WAN). With Internet becoming more and more popular, the intranet-internet-extranet technologies have found favour with manufacturing companies.

### **15.2.1 PRIVATE COMPUTER COMMUNICATION NETWORKS**

A manufacturing industry may have a number of plants situated at different locations in a country or in different continents. There is need for them to communicate each other to share resources and exchange information. An autonomous data communication network for this purpose is called a private computer communication network. The technology involved in such a network is discussed in detail later in this chapter. However Intranets and Extranets provide powerful, convenient and cost effective alternatives.

### 15.2.1.1 Virtual Private Network (VPN)

The desire to use the Internet for business and industry and the risk factors associated with doing so have given rise to a new technology paradigm called Virtual Private Networks (VPN). A VPN typically is Internet Protocol (IP) based network (usually the public Internet) that uses encryption and tunneling to achieve one or more of the following goals:

- Connect users securely to their own corporate network (remote access)
- Link branch offices to an enterprise network (Intranet)
- Extend organizations' existing computing infrastructure to include partners, suppliers and customers (Extranet)

Security of data is a major concern for manufacturing industries also. Every VPN solution provides some sort of encryption.

The two primary cryptographic systems in use today are secret key cryptography and public key cryptography. Secret (or private) key cryptography uses a shared key, which is used to encrypt and decrypt messages. The major problem with private key cryptography is key exchange. Sending secret keys across the Internet unencrypted is not an option for obvious reasons. Public key cryptography eliminates this problem. Public key cryptography uses a mathematically linked key pair for each communicating party. This means that data encrypted with one key can be decrypted with the other key in the pair. A sender can encrypt a message with the recipient's public key, which as the name implies is publicly available (on a server, for example). The recipient can then decrypt the message using his or her own private key.

An important issue is integrity of data. Integrity ensures that information being transmitted over the public Internet is not altered in any way during transit. A VPN may use one of three technologies mentioned below to ensure integrity:

- One way hash functions
- Message authentication codes
- Digital signatures

Authentication is another issue in security. Authentication ensures the identity of all communicating parties in the network. Authentication is based on password authentication or digital certificates.

The separate technologies used to provide confidentiality, integrity and authentication in a given implementation are grouped into a broad VPN protocol. Three widely used protocols are IPsec, tunneling and Socks5.

## 15.2.2 PUBLIC SWITCHED DATA NETWORKS

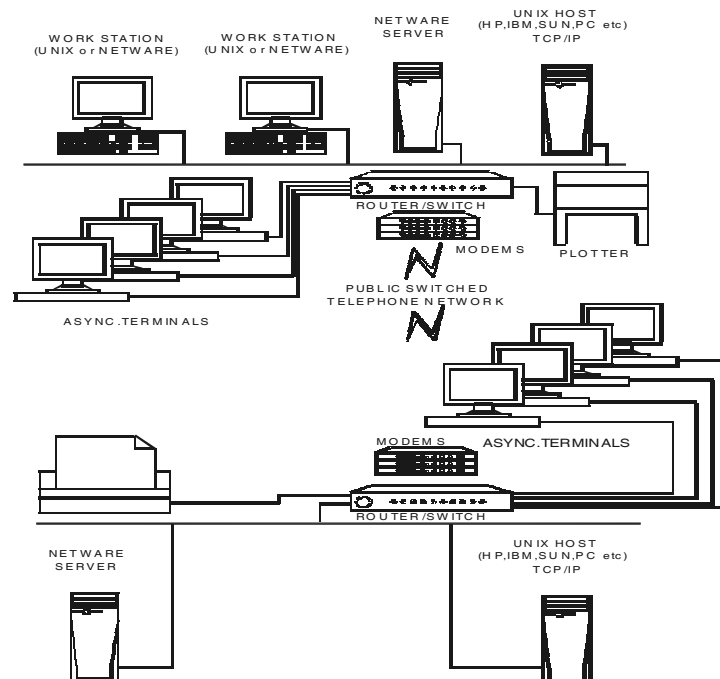
Initially organizations implemented their own private nation-wide data networks using communication lines leased from public telephone network. As computer technology grew and variety of computers increased, it became necessary to communicate between different types of computers in different organizations. This led to the development of public switched data networks (PSDN). The need for efficient transmission of voice and data has led to the development of Integrated Services Digital Networks (ISDN).

### 15.3 NETWORK TECHNIQUES

Network technology can be broadly classified into two categories. They are Local area network (LAN) or Wide area networks (WAN). LANs are intended to serve a number of users who are physically located close together. WANs are more akin to telephone network, tying different people in different buildings, cities or even countries. A message is routed through several interim points before reaching its final destination; a WAN may also incorporate the ability to automatically change to an alternate message routing path if the computer at one location fails. A LAN (local area network) has 2 to 10 times more traffic on it than a wide area network (WAN). Each individual point within a network that can communicate through the network is called a node. Each node is assigned a unique address. This way, a destination address can be put into each message and it can be sent to correct recipient.

### 15.4 LOCAL AREA NETWORK (LAN)

A network is a linking of a group of computers to communicate with each other and share software and hardware resources via the cables and interfaces that connect the computers and peripherals. Application softwares used in a network allow several users access the same program and data at the same time. As the name implies, a Local Area Network or LAN is a system that covers short distances. Usually LAN is limited to a single department or a single building or a single campus. Typical data transmission speeds are one to 100 megabits per second.



**Fig.15.1 A Typical Local Area Network**

Fig. 15.1 shows a typical network, in which two LAN's are shown, each networking a number of computers connected to its file server. A network connects together a number of workstations, as shown in the figure. Another way of interconnection is through a router to which a number of asynchronous terminals are connected. Remote access to another LAN can be affected through a Router-Modem-Public Switched Telephone Network-Modem-Router scheme. A router is intermediate equipment, which transfers data between two networks that use the same protocols. Modem is an equipment that connects a computer to a telephone line (usually voice grade). Modems also connect a large local network to a network provider over a leased line which is a dedicated communication line leased from the Department of Telecommunications (DOT) by one or more user organizations. Leased lines provide faster communication capability than dial-up lines. Common resources of the network include a bank of printers and plotters and facilities for disc mirroring and disc duplexing.

Local area networks (LANs) fall into different sizes. Their topology, access method, medium, and market are different throughout. It is a private data communications system covering a limited geographical area, which is typically about a kilometre long. A LAN lets a factory network communicate with computers vertically and horizontally. It allows sharing of input and output devices and databases. The LAN allows access to remote mainframes. Many LAN topologies are available today.

A LAN is capable of data transfer rates of 1-10 Mbits/sec in computer-to-computer communications. It also handles requirements of dissimilar devices found in various applications, involving human, machines, and databases. A LAN can integrate the hardware and data on shop floor. An advantage of a LAN is that it allows electronic communications to maintain, optimize, and use external database resources and process controls with less than 10 seconds response. It does appropriate filtering of messages so that bad messages cannot get through, and it allows downloading of program and data into production equipment like programmable controllers, numerical controllers, and microprocessors to facilitate flexible manufacturing. LANs allow machines and managers and supervisors to monitor the entire process by "zooming" onto any particular segment in as great detail as necessary. The LAN can monitor quality and make corrections, or, stop process to allow humans to make corrections, before the quality or yield of system goes down below acceptable levels.

A basic requirement of a LAN is that it must have a flexible architecture to permit PC's and other computers located where they are needed. It must also be possible to remove a computer without causing disruption. Reliability is another important aspect. Since the manufacturing activities depend upon the working of LAN, the LAN system must be highly reliable. The most widely used LAN system is Ethernet.

PC's attached to a LAN can use the processing capabilities of other intelligent devices in the network as in a host-to-terminal network.



## 15.5 COMPONENTS OF A SMALL LOCAL AREA NETWORK

A LAN in a CIM setup is a system comprising the following basic components:

- (i) **Computers:** (PC's, Design Workstations, CNC Systems, robots, PLC's etc.)
- (ii) **Network Cable:** A transmission cable is attached to each device (computer/peripheral) to enable the transmission of messages from one device to another. The details of cables commonly used are given in Table 15.1.

**Table 15.1 Cables Used in Networking**

<i>Type</i>	<i>Data Transmission Rate</i>	<i>Distance</i>	<i>Remarks</i>
Twisted pair	1 M bit/sec	Short distance 100 m	Least Expensive base band, single channel
Coaxial Cable -base band -broad band	10 M bit/sec 5 M bit/sec	up to 4 km up to 50 km	Multi Channel Capability
Fibre Optics	100 M bits or more		Multi Channel Large Capacity Expensive

The simplest form of Ethernet uses a passive bus operated at 10 Mbps. The bus is formed from a 50-Ohm co-axial cable, which connects all the computers in the LAN. A single LAN may have up to a maximum of 1024 attached systems, although in practice most LANs have far fewer. One or more pieces of coaxial cable are joined end to end to create the bus, known as an "Ethernet Cable Segment". Each segment is terminated at both ends by 50-Ohm resistors (to prevent reflections from the discontinuity at the end of the cable) and is also normally earthed at one end (for electrical safety). The computers are attached to the cable using transceivers or network interface cards.

The two major means of electrically carrying data on a LAN are as follows:

**BASE BAND** allows devices to send digital data at a set speed. All nodes in the LAN are exposed to data, but a node will ignore a message if it is intended for another node.

**BROAD BAND** is similar to cable television. A number of very high frequency signals are placed in line and data is sent using these signals as "carriers," in the same way as television uses several channels. Several "networks" can, in essence, share the same cable, because it is possible to filter out all but desired "carriers".

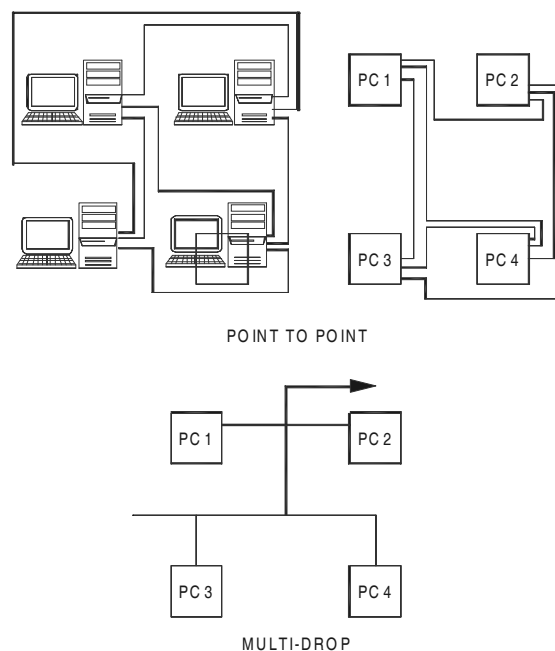
- (iii) **Network Interface Card (NIC):** This is communication hardware in the form of an add-on card for sending and receiving messages. This is also called

network adapter. NIC is plugged into one of the slots of the PC expansion slots and the transmission cable is attached to the connector provided on the card. A detailed description of network cards is given in section 15.7.

- (iv) **Network Server:** Network Server is the computer used to manage shared resources. Server is a combination of hardware and software. The file server performs the following tasks:
- Manages the shared hard disc
  - Makes sure that multiple requests do not conflict each other
  - Protects data
  - Prevents unauthorized access to databases and application programs
  - Maintains a list of privileges and authorizations
- (v) **Central Mass Storage:** The hard disc of the file server should have sufficient capacity (usually in term of several Gigabytes) to meet the storage requirements of the users of the network.

## 15.6 NETWORK WIRING METHODS

There are two basic ways by which three or more nodes can be incorporated in a network. These are point-to-point and multi-drop. (Refer Fig. 15.2)

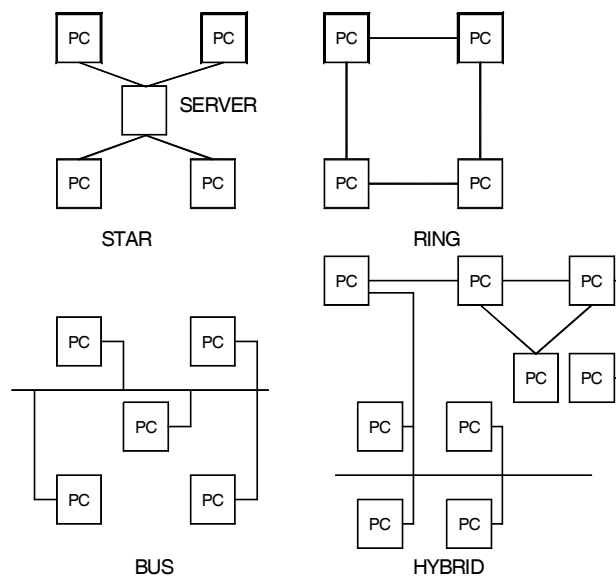


**Fig. 15.2 Network Wiring Methods**

### 15.6.1 NETWORK TOPOLOGIES

There are several commonly used network topologies, or ways of routing the interconnections. (Refer Fig. 15.3)

- (i) **Star Network:** This means running a separate cable or line between server and each node. This is useful when a master slave relationship exists between the server and the nodes. For sending data and files from one node to another a request should be made to the server, which establishes a dedicated path between the nodes. The data can be transmitted through this path.



**Fig. 15.3 Network Topologies**

- (ii) **Ring Network:** This involves connecting all nodes in series. The cable will normally loop back to form a full circle. This is some times used when nodes are widely separated, as each node can act as a repeater (amplifier) for message destined for downstream nodes. The data will have to pass through other nodes before reaching the server. The data is sent in the form of a packet which contains both source and destination addresses of the data. As the packet circulates through the ring the destination station copies the data into its buffer and the packet continues to circulate until it goes back to source workstation as an acknowledgement.
- (iii) **Bus Networks:** This type on interconnection allows all nodes to share the same cable. Any message that travels on the cable is “seen” by every node on the cable. This topology uses both base band and broadband transmission.
- (iv) **Hybrid Networks:** This includes features of more than one topology to achieve the optimal trade-off of reliability, performance, flexibility and cost.

### 15.6.2 TRANSMISSION MEDIA

The transmission of an electrical signal between two pieces of equipment requires the use of a transmission medium, which takes the form of a transmission line. The major types of transmission media are:

- (i) Two-wire open lines
- (ii) Twisted pair lines
- (iii) Co-axial cable
- (iv) Optical fibre
- (v) Microwaves

### 15.6.3 INTERFACES

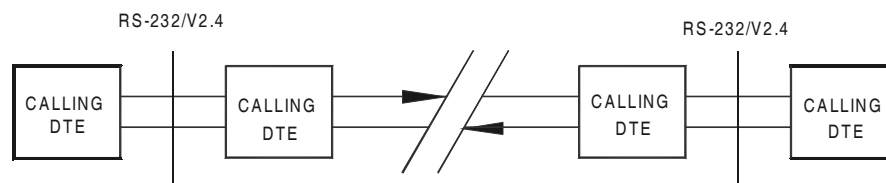
Several communication interfaces are used in computer-to-computer communications. They include:

RS-232C, RS-422, Modem

#### 15.6.3.1 RS-232C/V.24

RS-232C/V.24 standards were developed to connect a data communicating equipment (DCE) to a data communication terminating equipment (DTE).

The schematic diagram of a communication system arrangement is shown in Fig. 15.4.



**Fig. 15.4 Communication System Arrangement**

RS-232C uses a 25 pin D-connector. An alternative type of electrical signal that is sometimes used instead of RS-232C standard is the 20mA current loop. This uses a current signal and substantially increases the physical separation of the two communicating devices.

#### 15.6.3.2 RS-422/V.11

If the physical separation and the bit rates are to be increased RS-422/V.11 signal definition can be used. These are based on the use of a twisted pair cable and a pair of differential transmitter and receiver circuits.

#### 15.6.3.3 MODEMS

When the data are to be transmitted over telephone lines it is necessary to convert the electrical signal output from the DTE into a form that is acceptable to public switched

telephone network (PSTN). PSTN has a bandwidth of 400 to 3400 Hz. Hence the binary data cannot be directly transmitted. Instead, it is necessary to convert the binary data into a form compatible with the speech signal at the sending end of a line (modulation) and to reconvert this signal back into its binary form at the receiver (demodulation). Since each side of a data link must both send and receive data, the combined device is called a modem.

While variety of network topologies have been used both for LANs and WANs, the bus arrangement has been gaining popularity for LANs. With this technique, all nodes are connected to the same conductors or the same cable, in parallel. In this technique, it is possible to spread the requirements and access privileges across the entire network. This ensures both responsiveness and reliability. Since all nodes share the same electrical pathway, it is necessary to have a universally agreed upon (within the network) way to control the data traffic on this type of network.

## 15.7 NETWORK INTERFACE CARDS

Each workstation as well as the file server has a network interface card which is an add-on to the mother board which allows a workstation to communicate to another and the file server, through a communication medium such as cabling and provides the necessary connection for the same. Two typical cards are ARCNET and ETHERNET cards.

### 15.7.1 ARC NET CARDS (ATTACHED RESOURCE COMPUTING)

This card is based on combined star and bus topologies and operates with a base band. It is rugged and fairly maintenance free. Its speed is 2.5 MB/sec and uses 93 ohms RG-62 Co-axial cables as medium of transmission.

### 15.7.2 ETHERNET CARDS

Ethernet (developed by Xerox and DEC) also uses Co-axial cables with a speed of 10-100 MB/sec. This card is designed for bus topology with CSMA/CD access method. The salient features of two types of Ethernets are given in Table 15.2.

**Table 15.2. Ethernet Types**

	<i>Thick Ethernet</i>	<i>Thin Ethernet</i>
Cable	100 mm dia. 50 ohm	5 mm dia. 500 Ohm
Segment Length	500 meters	300 metres
Total length between repeaters	2500 metres	1000 metres
Max. no. of computers	several hundred	100 metres

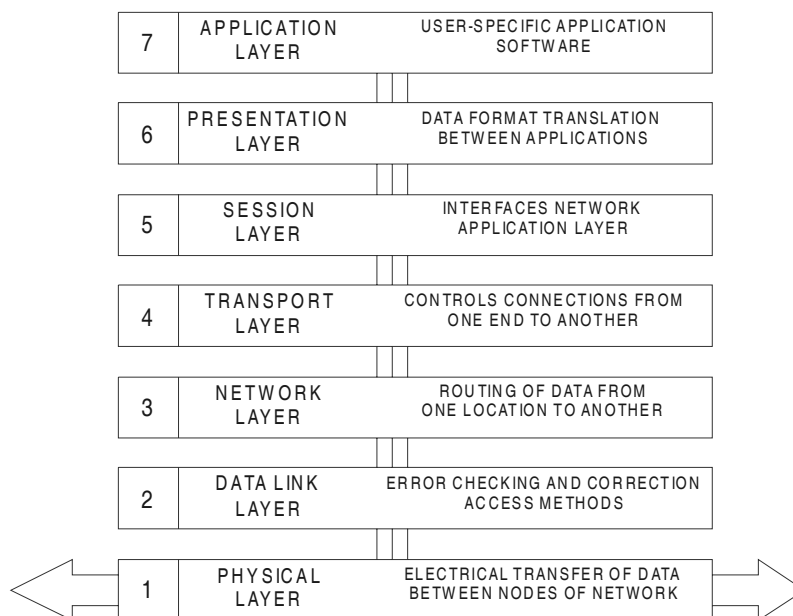
## 15.8 NETWORKING STANDARDS AND THEIR DEVELOPMENT

The International Standardization Organization (ISO) developed a model for data communications. This is known as ISO-Open System interconnection (OSI) model. This model is shown in Fig. 15.5. This standard defines a series of seven layers in which communication processing takes place.

These protocol layers are:

Physical layer	Data link layer
Network layer	Transport layer
Session layer	Presentation layer
Application layer	

Each layer contains a specific set of functions. It is organized such that any given layer may be implemented in a number of ways and remains compatible with layers above and below it. There have been also standard protocols and techniques established for implementing individual layers. An example of these is the Institute of Electrical and Electronics Engineers (IEEE) 802 LAN standards, which define certain ways of implementing Layers 1 and 2.



**Fig. 15.5 OSI Model for Network Communications**

The National Bureau of Standards (NBS), the European Computer Manufacturers Association (ECMA), and the Consultative Committee on International Telephony and

Telegraphy (CCITT) and American Standards Institute (ANSI) are establishing middle and higher-level protocols. The seven layers of the ISO-OSI model are described below:

### **15.8.1 PHYSICAL LAYER**

Level one is the physical layer. It defines the physical connection between the computer and the network communication system. This connection includes cables, connectors, and modulation equipment and specifies the frequencies and voltages of connectors. The bandwidth of the cable transmission and the physical layout (topology) are defined in this layer.

Traffic control is necessary within any given channel, and various techniques exist for handling this control.

**NETWORK TRAFFIC CONTROL:** It is necessary to regulate the transmission of information in a network. A frequently used technique for controlling traffic on a network is CSMA/CD (Carrier Sense Multiple Access/Collision Detect). When a node has message to send, it listens on the line to see if any other message is in the process of being sent. If not, it broadcasts its message on the line. The receiving node acknowledges it.

There is a chance that two nodes will begin transmitting at the same time. The collision detect action determines when this happens by measuring a higher energy level in the line. Both nodes involved in the collision wait for a random period of time (each different) and try again.

Another popular network control method is called token passing. Here, the right to transmit data is called a token, and this token is passed from one node to another node in an organized fashion. Whichever node has the token has right to transmit data for a pre-set maximum amount of time. It must then next pass the token to the next node in sequence. If a node is sending and maximum time passes before all data is sent, that node must be stop sending and pass the token. It may resume when it gets the token back again. An advantage of this method is that one can compute the maximum amount of time any given node will have to wait before receiving the token and being able to send messages.

Two major token-passing schemes are token ring and token bus. Token ring uses nodes connected in a ring structure whereas token bus utilizes a bus network.

### **15.8.2 DATA LINK LAYER**

Level 2 defines how the data is to be packaged when it is sent between physical connections. This layer defines the network access control mechanisms. The formats used in network message units are also defined here. LANs do not send messages as a continuous stream. Instead, messages are broken up into message units called packets. Each packet carries the addresses of its source and destination along with suitable error detection mechanisms. An established protocol is higher level Data Line Control (HDLC). Another is Bisynchronous Communication (BSC). These are two standardized ways of transmitting data.

### 15.8.3 NETWORK LAYER

This layer defines switching and routing information between networks and how packets of data are exchanged between different LANs. An example is the X.25 standard, which defines standards for packet switching networks.

### 15.8.4 TRANSPORT LAYER

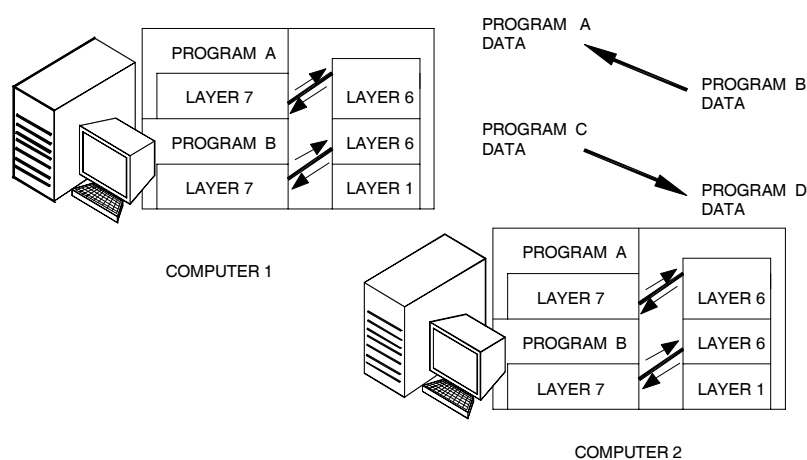
The transport layer defines network addressing and the way in which connections between networks can be linked or unlinked. The transport layer guarantees the message delivery with no omissions or duplications.

### 15.8.5 SESSION LAYER

The primary function of this layer is to define an application interface to the transport layer. This layer maps names to network addresses so that applications can use names to communicate with devices.

Layers 3, 4 and 5 combine to form a sub-net level containing the software, which controls the network hardware. Though cables are attached to every device in a network, actual communication involves only two devices—the sender and the receiver. The subnet level establishes and manages a temporary link called virtual connection between the sender and the receiver.

At levels 4 and 5, the major concern is about how applications in different LANs communicate. Consider two computers on a LAN, each running different programs. (See Fig. 15.6.) Program A on computer 1 needs to exchange data with program C on computer 2; program B on computer one needs to talk with program D on computer 2. Level 4 of OSI establishes virtual channels, effectively isolating each pair of communicating programs from other sets of programs talking over the network.



**Fig. 15.6 Communication between Different Applications**



### **15.8.6 PRESENTATION LAYER**

This layer defines the translation formats and syntax from an application to the network and the manner in which software applications enter the network.

### **15.8.7 APPLICATION LAYER**

This layer contains several programs that define the network applications that support file serving.

The developments in computer communication during the last two years have significantly simplified the communication protocols.

## **15.9 EXAMPLES OF NETWORK STANDARDS**

Several computer manufacturers and organizations have developed systems for network communications.

### **15.9.1 DECNET**

DECNET is a trademark of former Digital Equipment Corporation. This is a good example of a network following Level 2 through 8 of the ISO OSI standard. DECNET allows change of files between computers. It allows a terminal attached to computer A to interact with computer B in another location. In advanced applications, it even supports distributed databases. It is a software protocol, where a number of different electrical and line protocols may be used to support it. For example DECNET is used in a hybrid, point-to-point network. It may also use Ethernet as an electrical protocol.

### **15.9.2 SYSTEM NETWORK ARCHITECTURE**

IBM's System Network Architecture (SNA) is a network management scheme used primarily for peer-to-peer communications between computers. It has become a de-facto standard for interconnection of large mainframes, due to popularity of IBM and IBM compatible hardware. Gateway devices are available from several manufacturers to interface between SNA and various LANs. SNA to non-IBM computer interfaces are also available. Several other vendors also supply SNA interfaces.

### **15.9.3 MANUFACTURING AUTOMATION PROTOCOL (MAP)**

MAP is a hardware/software protocol developed jointly by a group of industries and vendors of computers and PLCs. It follows the ISO OSI model. MAP was developed as a result of the plans of General Motors to automate its factories.

MAP uses a broad band LAN, with a token ring protocol for traffic control. Since it is broadband, all devices in the LAN like computers, CNC machines, robots, and PLC's etc. share the same cable, but different groups of devices can be placed on separate "channels" on the line. Additionally, closed circuit TV (video) channel can also be accommodated on same cable. MAP physical level is based on the IEEE 802.4 token-bus standard. At the

data link level, it uses the IEEE 802.2 logical control standard. MAP also uses 8473 network layer protocol for connectionless-mode network service.

#### 15.9.4 TECHNICAL OFFICE PROTOCOL (TOP)

TOP is another widely used protocol, developed by Boeing Computer Services. It is similar to MAP in several respects. TOP is the initiative of a group of computer system purchasers. The members of TOP group include Boeing, General Motors, Du Pont, McDonnell Douglas, Ford Motors, Procter and Gamble and Eastman Kodak.

In a multi-vendor computing environment, common communication methods are required for integration and automation of processes. TOP addresses the problem of providing multi-vendor compatibility and communications in the technical office functions.

Thus, TOP is an application-oriented implementation of the OSI protocols. TOP, like MAP is based on the seven-layer OSI model. But, unlike MAP, TOP does not have to address the needs of a harsh shop floor environment. Applications, which it is designed to integrate, are electronic mail, word processing, document exchange, file transfer, graphics interchange, database management, batch processing, and videotext and business analysis. TOP provides peer-level, process-to-process, and terminal-access communications for computers ranging from personal computers to workstations and mainframes.

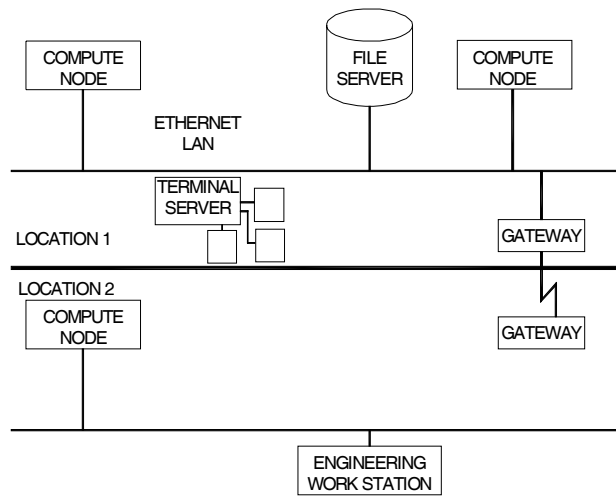
TOP also interconnects office tasks with the factory floor via its interface with MAP. Table 15.3 shows a comparison of MAP and TOP. A complete TOP system will include one or more building blocks covering layers one to four and at least one building block for layers 5 to 7.

**Table 15.3 Comparison of MAP and TOP Protocols**

<b>LAYER</b>	<b>MAP</b>	<b>TOP</b>
LAYER 7 - APPLICATION	ISO FTAM 8571	ISO FTAM 8571
LAYER 6 - PRESENTATION	NULL	NULL
LAYER 5 - SESSION	ISO 8327	ISO 8327
LAYER 4 - TRANSPORT	ISO 8073 / CLASS 4	ISO 8073 CLASS 4
LAYER 3 - NETWORK	ISO 8473	ISO 802.2
LAYER 2 - DATA LINK	IEEE 802.2	ISO 802.2
LAYER 1 - PHYSICAL	IEEE 802.3	ISO 802.4

#### 15.10 ETHERNET

A currently available example of standardization of level 1 is the Ethernet network, which is a joint work of Xerox, Digital Equipment Corporation and Intel. The Ethernet network is shown in Fig. 15.7. Ethernet network is base band network, utilizing CSMA/CD and operating at 10-100 million bits per second. Up to 1,024 nodes may be connected within a network. It uses linear bus topology.



**Fig. 15.7 Layout of an Ethernet Network**

**There are two types of Ethernet Cables:**

**Thick Ethernet:** Thick Ethernet is 10 mm diameter (50 ohm) co-axial cable, which can span up to 2.5 km. It can support several hundred computers.

**Thin Ethernet:** This 5mm diameter cable (500 ohm) can span up to 1 km and support up to 100 computers.

Several Ethernet-type products are provided for personal computers. The term to describe the product line is Ether series. Etherlink is the data communications product of Ether series. Ethershare is a file-serve support package. It manages discs at the disc volume level and provides for multiple uses into files.

Ethershare provides other functions, such as a print support package called Etherprint. Etherprint is a powerful print serving function. It allows user to perform multiple printing simultaneously without interfering with each other. The server keeps separate buffers on the disc and interleaves various users onto the printer as they close their files.

## 15.11 ISSUES IN INTER-SYSTEM COMMUNICATION

There are several issues to be considered in network communication.

### 15.11.1 TERMINAL NETWORKING

Any given network usually contains several different kinds of computers, with many different kinds of data. Networking, makes it possible for a given individual terminal or workstation to access many different computers on the network. Terminal networking does this. Terminal networking allows the user to enter some commands, which instruct

the appropriate network device to establish communication between the user's terminal and the desired computer. A lot of flexibility is provided by this arrangement. For example, any given node can be more specialized and optimized to its task-yet locally attached users are not confined to narrow range of capabilities, but rather can have access to the full range of functionality afforded by the network. With this flexibility comes a requirement for great care in system operation.

### 15.11.2 FILE SHARING

When it is necessary to share and/or transfer files across a network from one network node to another file sharing is used. The steps involved in file sharing are:

- (i) Understand and service file requests coming from any where in the network.
- (ii) Realize when the user needs to access a file which is stored at another network node, then request the file from the INPUT/OUTPUT driver on the other system, via the network.

From the stand point of a given network node, this technique can be used to access and read a file from another node, and also send a file to another node.

### 15.11.3 DATA TRANSLATION

Physical capability of exchanging data between two computers does not automatically guarantee that the programs on one computer will be able to decipher data stored on the other. The data on one system may be stored in a format, which is unintelligible to programs on the other system. Because of this, it is important to consider the requirements and techniques for data translation networks. This is especially critical when you plan to mix hardware and/or software from different vendors in a network.

### 15.11.4 DISTRIBUTED DATABASE

An input/output driver can also be designed to read or write individual records within a file across the network. In the case of a structured file system like a relational, hierarchical or network database remote access requires many issues to be dealt with.

The design of database structure is affected by network topology. Specifically, this means that you can place a given type of data on the individual computer that uses it most. For example, consider a distributed database of a manufacturing company, which includes production statistics from its foundry department. The data can reside directly on the foundry's computer and nowhere else.

Later, when a program running on the plant computer is doing a summary of total factory production and needs the data on the foundry computer, the plant computer accesses these records directly. The plant computer may also write some records into the foundry's production plan database indicating new production requirements.

## 15.12 NETWORK OPERATING SYSTEMS

A network operating system (NOS) includes special features for connecting computers and devices into a LAN. Some operating systems like UNIX and MAC OS have networking functions built in. Generally, the term NOS is applied to software that enhances the capabilities of a basic operating system by adding networking features. Examples are Novell Netware, LANtastic, Microsoft Windows Server and Windows NT.

The network operating system supports applications on network. The functionality, ease of use, performance, management and data security depend upon the network operating system. A network has to support a number of utilities, which include:

- (i) File server management utilities to manipulate file server resources such as mass storage devices
- (ii) Print server management utilities to enable the user to print using a shared printer
- (iii) Login utility to implement the procedure to enter a network
- (iv) Directory specification utility similar to password privileges
- (v) Locking utility
- (vi) Electronic mail
- (vii) Transaction tracking
- (viii) Disc duplexing

***Network operating systems also provide the following functions:***

- File and print sharing
- Account administration for users
- Security
- Client functionality
- Server functionality
- Account administration for users
- Security
- User administration
- Backing up data

Commands in typical network software are given in Table 15.4

**Table 15.4 Commands in Typical Network Software**

<b><i>Command</i></b>	<b><i>Function</i></b>
BROADCAST	Sends messages to all computers
CHANGE QUEUE	Changes print queue job priority
CLEAR STATION	Disconnects a station from all resources
CONFIG	Displays a list of server installed interface cards

<b>Command</b>	<b>Function</b>
DISABLE LOGIN	Prevents workstation login
DOWN	Clears network preparatory to power off
ENABLE LOGIN	Allows login
NAME	Displays file server name
OFF	Clears console screen
SEND	Send a message to specified workstation
HIDEFILE	Prevents a file from being displayed
CHKVOL	Displays disc drive statistics
LISTDIR	List directories
PURGE	Erase files
SALVAGE	Recover erased file
UDIR	Global file searching
WHOAMI	Displays user information

### 15.13 SYSTEM SECURITY

When there are numerous terminals on a network, there are security considerations that must be taken into account. Precautions that can be taken range from double password and password-changing system to sophisticated hardware, which provides authorized user callback and/or data encryption. Security scheme suitable for particular situations should be incorporated in a network.

### 15.14 MANAGING REMOTE SYSTEMS IN A NETWORK

The wide use of personal computers and minicomputers in all aspects of a manufacturing organization has created problems of managing remote systems and networks. When small systems are located over widely separated geographic areas, it is not cost effective to provide dedicated system management staff at each location. There are two ways of dealing with this situation:

- i. Download the remote system software. In this arrangement, the software for all computers is maintained at a certain site. When it is necessary to “re-boot” the remote system, the software is transmitted over the network to the remote computer. This requires that the remote computer to be capable of loading its operating system across the network. This is practical only when the operating system is small enough and network speeds are high enough to allow a timely download.
- ii. Maintain the software centrally but send it down to the remote site where it is stored. After that, the system re-boot uses locally stored operating system programs. This requires that the central support staff be able to fully control the remote computer from the central location. Some network systems provide for this level of remote control.

### 15.15 DESIGN ACTIVITY IN A NETWORKED ENVIRONMENT

Several large-scale design activities require several engineers (sometimes even hundreds) to work on different aspects of design; Examples are design of aircrafts and VLSI and UVLSI chip designs. Such designs are efficiently carried out in a networked environment.

In a network linking several CAD systems, a situation may arise where designers at several different locations need to access the same design data. Design control, in its simplest form, ensures that two different designers never modify the same design independently. Unless this situation is somehow controlled, design can be lost, because the second designer to save his change will wipe out the work done on that design by the first designer.

What is required here is a system, which allows an authorized designer to check out a design. While the design is being modified, a copy of the original design is retained by the system, but nobody else can work on that design. The system must also maintain the identity of the designer who has checked it out. This type of system is especially important on a network, where many users can potentially and inadvertently conflict with each other.

### 15.16 ENGINEERING CHANGE CONTROL

Engineering changes frequently occur and should be communicated to all the personnel concerned. A network almost necessarily implies a large organization, or at least one scattered across a geographical area; otherwise, there would be no need for network. Therefore, a networked system is likely to have a need for automatic notification of various people involved when an engineering change is effected. One of the requirements of CIM is the effective communication and networking helps a lot in this regard.

There are several milestones in an engineering change:

- i. When ordered (and why and by whom)
- ii. When change is incorporated in design
- iii. When change becomes effective for production

Because engineering changes can affect other aspects of manufacturing, companies often implement systems, which are driven by engineering changes. These systems perform functions such as:

- i. Automatic distribution of changed drawings to all areas requiring these.
- ii. Maintenance of history of changes for contract reasons. Effective engineering change control will eliminate wastages and delays in a manufacturing organization.

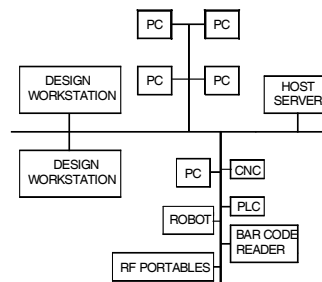
### 15.17 NETWORKING IN A MANUFACTURING COMPANY

A manufacturing company carries out a number of operations using computers.

**These include:**

- Master production scheduling and planning
- Pay roll and human resources management
- Purchasing and receiving
- Order entry and invoicing
- Shop management
- Warehouse management
- Tool crib management
- Time keeping
- Quality control
- Shipping
- Materials handling
- Inventory control
- Processing operations
- Marketing

There are software solutions to carry out the above and many others (not listed here) tasks. These are implemented in different types of computers. In addition, several devices like bar code readers and RFID tags will be used for data collection and input. All these are to be connected in a LAN for effective operation. Fig. 15.8 shows a typical Factory LAN and the various equipment connected to the LAN.



**Fig. 15.8 A Typical Factory LAN**

### 15.18 NETWORK FILE SYSTEM (NFS)

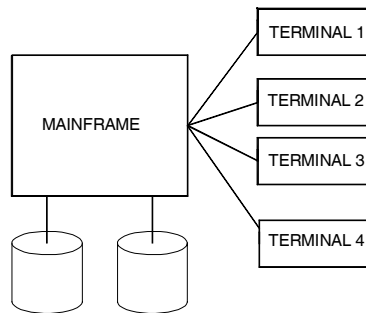
Software tools are necessary for sharing files in a network. The Network File System is a facility for sharing files in a heterogeneous environment of machines, operating systems and networks. Mounting a remote file system, then reading or writing files in place, since these units may use different operating systems accomplishes sharing. A brief description of Network File System is included in this chapter to enable the readers to understand the capabilities of a typical network file system used in workstations.



Operating system independence was taken as an NFS design goal, along with machine independence, crash recovery, transparent access and high performance. NFS was thus designed as a collection of network services, and not as a distributed operating system. As such, it is able to support distributed applications without restricting the network to a single operating system. Because of NFS's open design, applications of different vendors will be able to work together on a single network.

### 15.18.1 COMPUTING ENVIRONMENTS

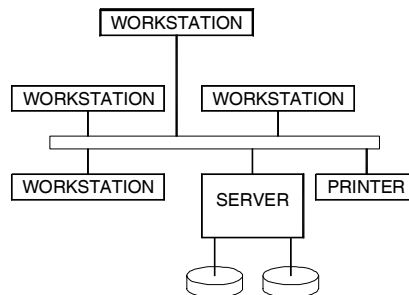
The traditional timesharing environment is shown in Fig. 15.9. The major problem with this environment is competition for CPU cycles.



**Fig. 15.9 Time-sharing Environment**

The workstation environment solves that problem, but requires more disc drives. A networked environment is shown in Fig. 15.10.

The goal of the NFS design was to make all discs available as needed. Individual workstations have access to all information residing anywhere on the network. Printers, plotters etc. may also be available somewhere on the network.



**Fig. 15.10 Networked Environment**

### 15.18.2 EXAMPLE NFS USAGE

This section gives three examples of NFS usage.

**Example 1: Mounting a Remote File System**

Suppose your machine name is client, that you want to read some on-line manual pages, and that these pages are not available on your server machine, named server, but are available on another machine named docserv. Mount the directory containing the manuals as follows:

```
client# /usr/etc/mount docserv: /usr/man /usr/man
```

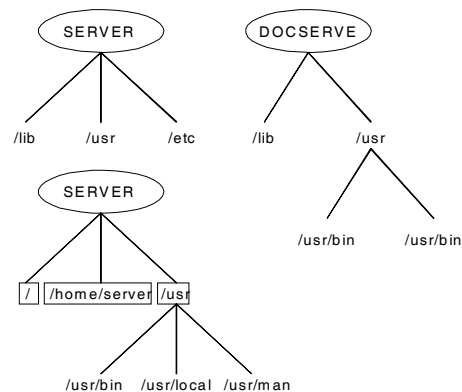
Note that you have to be super user in order to do this. Now you can use the man command whenever you want. If you run the mount-p command (on client) after mount the remote file system, its output will look something like this:

```
server:/roots/client      /           nfs rw, hard    00
server:/usr                /usr        nfs ro           00
server:/home/server       /home/server nfs rw,bg       00
server:/usr/local         /usr/local  nfs ro,soft,bg  00
docserv:/usr/man          /usr/man    nfs ro,soft,bg  00
```

A user can remote mount not only file systems, but also directory hierarchies inside file systems. In this example, /usr/man is not a file system mount point—it is just a subdirectory within the /usr file system. Fig 15.11 shows a few key directories of the three machines involved in this example. Ellipses represent machines, and NFS mounted file systems are shown boxed. There are five such boxed directories, corresponding to the five lines shown in the mount -p output above. The docserv: /usr/man directory is shown mounted as the /usr/man directory on client.

**Example 2: Exporting a File System**

Suppose that you and a colleague need to work together on a programming project. The source code is on your workstation, which is a discless node or has a local disc. Suppose that after creating the proper directory your colleague tried to remote mount your directory. Unless you have explicitly exported the directory, your colleague's remote mount will fail with a "permission denied" message.



**Fig. 15.11 NFS**

To export a directory, first become superuser and then edit the `/etc/exports` (8) (after putting this line in `/etc/exports`):

```
/usr/proj    -access=cohort
```

If no explicit access is given for a directory, then the system allows anyone on the network to remote mount your directory. By giving explicit access to cohort, you have denied access to others. The file `/etc/xtab` contains the entries for directories that are currently exported. Now your cohort can remote mount the source directory by issuing this command:

```
cohort# /etc/mount client:/usr/proj /usr/proj
```

This, however, is not the end of the story, since NFS requests are also checked at request time. If you do nothing, the accesses that you have established in your `/etc/exports` file will stay in effect, but you (and your programs) are free to change them at any time with the `exportfs` command and system call. Since both you and your colleague will be able to edit files on `/usr/proj`, it would be best to use the `scs` (source code control system) for concurrency control.

### ***Example 3: Administering a Server Machine***

System administrators must know how to set up the NFS server machine so that client workstations can mount all the necessary file systems. You can export file systems (that is, make them available) by placing appropriate lines in the `/etc/exports` file. Here is a sample `/etc/exports` file for a typical server machine:

```
/                -access=systems
/exec            -access=engineering:raj:rupees
/usr             -access=engineering
/home/server     -access=engineering
/home/local.sun2 -access=engineering:proto
/home/local.sun3 -access=engineering
```

Machine names or net groups, such as `staff` may be specified after the file system, in which case remote mounts are limited to machines that are a member of this net group. At any time, the system administrator can see which file systems are remote mounted by executing the `show mount` command.

## **15.18.3 NFS ARCHITECTURE**

### **Transparent Information Access**

Users are able to get directly to the files they want without knowing the network address of the data. To the user, all NFS-mounted file systems look just like private discs. There's no apparent difference between reading or writing a file on a local disc, and reading or writing a file on a disc in the next building. Information on the network is truly distributed.

## Different Machines and Operating Systems

No single vendor can supply tools for all the work that needs to get done, so appropriate services must be integrated on a network. NFS provides a flexible, operating system-independent platform for such integration.

## Easily Extensible

A distributed system must have an architecture that allows integration of new software technologies without disturbing the software environment. Since the NFS network-services approach does not depend on pushing the operating system onto the network, but instead offers an extensible set of protocols for data exchange, it supports the flexible integration of new software.

## Ease of Network Administration

The administration of large networks can be complicated and time-consuming, yet they should (ideally) be at least as easy to administer as a set of local file systems on a timesharing system. The UNIX system has a convenient set of maintenance commands developed over the years, and the Network Information Service (NIS), a NFS-based network database service, has allowed them to be adapted and extended for the purpose of administering a network of machines. The NIS also allows certain aspects of network administration to be centralized onto a small number of file servers, e.g. only server discs must be backed up in networks of discless clients.

## Reliability

NFS's reliability derives from the robustness of the 4.2 BSD file system, from the stateless NFS protocol, and from the daemon-based methodology which network provides services like file and record locking. In addition, the file server protocol is designed so that client workstations can continue to operate even when the server crashes and reboots.

The major advantage of a stateless server is robustness in the face of client, server, or network failures. Should a client fail, it is not necessary for a server (or human administrator) to take any action to continue normal operation. Should a server or the network fail, it is only necessary that clients continue to attempt to complete NFS operations until the server or network gets fixed. This robustness is especially important in a complex network of heterogeneous systems, many of which are not under the control of professional operations staff.

## High Performance

The flexibility of NFS allows configuration for a variety of cost performance trade-offs. For example, configuring servers with large, high-performance discs, and clients with no discs, may yield better performance at lower cost than having many machines with small, inexpensive discs. Furthermore, it is possible to distribute the file system data across many

servers and get the added benefit of multiprocessing without losing transparency. In the case of read-only files, copies can be kept on several servers to avoid bottlenecks.

## 15.19 INTERNET

Internet is the mother of all networks and is a gigantic network of networks that connects presently several million people and millions of computer sites. These computer sites are spread all over the world at various government locations, corporate offices, colleges and universities and research institutions. All those people and millions like them who are linked up to the Internet can talk to each other by way of exchanging electronic messages in real time.

There are literally hundreds of databases that let people access information ranging from CAD data, manufacturing data, medical information, economic data, GIS and engineering tables. This superhighway of information makes available millions and millions of computer files filled with sound and video clips. Literally anybody can take these and people can exchange notes, reviews and views with each other via USENET newsgroups and bulletin boards.

### 15.19.1 THE EVOLUTION OF THE INTERNET

The Department of Defense of the United States established a network called ARPANET. It was designed to be an experimental network that supported US military research on networks that could withstand disasters like power failures, nuclear or bomb attacks. The idea was that the network must be up and running despite these disasters. The basic philosophy was that every computer on the network could talk, as a peer, with any other computer.

So whenever you wanted to send a message on the network, all you had to do was to get onto your computer that would put your data in an envelope, called an Internet Protocol (IP) packet, "address" the data or packets correctly. The communicating computers—not the network itself—were also given the responsibility to ensure that the communication was accomplished. Instrumental in the development of the Internet Protocol was the International Standards Organization (ISO) who spent years and years also designing, according to them the ultimate standard in computer networking. Scores of Internet developers in response to market demands started placing the Internet Protocol Software on all types of computers. So makers of computers realized that it is the logical method by which their computers could communicate to each other. This became a highly attractive proposition to the US government and the Universities. Everybody had the freedom to decide which one they liked to buy and also expected those computers to work together over the network.

A few years' later Ethernet local area networks (LAN) and workstations with Berkeley UNIX (which came up with IP networking) appeared on the computing scene. With the arrival of these new workstations a new type of demand was created. Instead of hooking

up to one large timesharing computer per site, institutions wanted to connect the ARPANET to their entire local network. This would allow all the computers on that LAN to access ARPANET facilities. At the same time, other organizations started building their own networks using the same communication protocols as the ARPANET namely, IP and its relatives. It became obvious that if these networks could talk together, users on one network could communicate with those on another; everyone would benefit.

One of the most important of these newer networks was the NSFNET, run by the National Science Foundation (NSF), an agency of the US Government. In the late 80's the NSF created five supercomputer centres. By creating supercomputer centres, the NSF was making these resources available for any scholarly research. Only five centres were created because they were so expensive — so they had to be shared. This created a communications problem: they needed a way to connect their centres together and to allow the clients of these centres to access them.

In response, NSF decided to build its own network, based on the Arpanet's IP technology. It connected the centres with 56,000 bit per second (56 kbps) telephone lines. It was however, very expensive. Therefore, they decided to create regional networks. In each area of the country, colleges would be connected to a supercomputer centre at one point, and the centres were connected together. With this configuration, any computer could eventually communicate with any other by forwarding the conversation through its neighbours.

### **15.19.2 FILE TRANSFER PROTOCOL (FTP)**

FTP stands for File Transfer Protocol. It is both a program and the method used to transfer files between computers on the Internet. Anonymous FTP is a type of FTP that lets the user transfer any of more than 2 million files from several thousand computers on the Internet to the personal computer or computer account. By using FTP, the Internet becomes like a huge disc drive attached to the computer. FTP sites contain books, journals, software, games, images, sound, multimedia, courseware, datasets and other information available for the user to transfer. There are a variety of FTP programs, but most of them work in the same way.

### **15.19.3 CLIENT/SERVER**

The purpose of having computers communicate with each other in a client/server mode is that they can both share the work. In the early years of computer development, mainframes sent information out to dumb terminals, and the mainframe had to do all the work. This also allows the user, for example, to take advantage of always-improving client software, which a user can install in the PC, while the software on the server machine may remain the same.

### **15.19.4 WORLD WIDE WEB (WWW)**

World Wide Web is an innovative hypertext front-end program based on client/server architecture that allows the user to access information on the Internet as if

it were a part of a seamless web. The goal of WWW is to make all online knowledge part of one interconnected web of documents and services, and allow the user to follow facts and texts wherever they might lead. For systems with “character only” displays such as UNIX, DOS and VMS one has to use line browser software in which one moves through the web by typing line numbers. On systems like Windows, X-windows, and Macs these are client programs that allow the user to make links by clicking and pointing.

### **15.19.5 INTRANET**

INTRANET can be defined as a manufacturing organization’s use of world wide web and related Internet technology to accomplish its primary objectives, viz., helping in production of superior quality goods with substantial decrease in operating costs, or achieving total customer satisfaction, maintaining healthy employer—employee relationship etc.

An Intranet is designed to distribute corporate information within an organization to organization’s own people. Using Intranet, web and related technology can be put to maximum use to further the purpose of the organization. People may include both employees and valuable customers of that organization. In the broadest sense, both internet and intranet use the same technology. However, Intranet is an organizational network, whereas Internet is a global one, which embraces thousands of servers providing wide range of information. Intranet has access to Internet but not vice versa.

Intranets are internal networks that the employees’ can access for information by simple browsing as on the world wide web. It acts as a reservoir of company information. It is a very effective platform for the employees to discuss projects and share ideas. Intranet enhances project management and reporting systems and improves workflow and increases productivity. Another very significant advantage of intranet is that it permits employees share information with colleagues spread over various locations simultaneously. The following are the major applications of intranet:

- i. Mail
- ii. Publishing corporate documents
- iii. Access to searchable directories
- iv. Corporate / Department / individual web pages
- v. Workgroup collaboration
- vi. Software distribution
- vii. User interface using HTML

A company, which has manufacturing division spread geographically, can make use of internet technology for effective workflow automation and collaborative product development or collaborative product commerce. The company can set up intranet at the headquarters. Each division can have its own intranet, which can be linked to the intranet at the Head Quarters through internet. The divisional intranets can be called

extranets. Thus, the entire manufacturing organization can be linked into a single networked entity.

## 15.20 HARDWARE ELEMENTS OF A NETWORK

Introduction of CIM necessitates every manufacturing engineer to be aware of the basic hardware elements of a network. The components required for a small network (say restricted to a computerized design action or production planning department) have been described earlier. This section gives a brief overview of these elements used in an Ethernet network, which can cover an entire manufacturing plant.

### 15.20.1 LAN ADAPTERS

These adapters are used for client workstations running DOS and Windows or OS/2 or for servers with ISA buses. Network adapters have been discussed in an earlier section. The LAN Adapter for Ethernet provides installation flexibility with connections for 10BaseT, 10Base2 and AUI.

#### **Features:**

- Support for 8 or 16 bit ISA slots.
- Software configurability.
- Programmed I/O or shared memory mode operation.
- Support for Novell Netware, Banyan VINES, Artisoft LANtastic SCO, UNIX, Microsoft Windows NT, DEC Patchworks. IBM OS/2 LAN Server and Microsoft LAN Manager networking operating systems.
- Remote Program Load.
- Diagnostic check and power-up.

### 15.20.2 ETHERNET SWITCH

Using high-speed, parallel paths among connected Ethernet LAN segments and devices uses Ethernet Switch to increase bandwidth 400 percent. By using this switch, LAN congestion is reduced, so frequent LAN users get extra capacity without crowding out others on the same network.

#### **Features:**

- Lowers costs per port without adding bridges and routers.
- Connects to a variety of hubs and concentrators.
- Provides aggregate bandwidth of up to 100Mbps through media speed frame transfer between four pairs of ports.
- Supports large, high-speed switch networks by using up to four full duplex links for a maximum bandwidth of 100 Mbps.
- Improves security by controlling traffic flow to specific addresses or within a defined group of virtual switch ports.
- Enables remote configuration and microcode download.



### 15.20.3 ETHERNET WORKGROUP HUBS

Workgroup hubs allow the addition of up to 8 or 16 stations to an existing Ethernet network to prevent network congestion. They automatically partition any port connected to a device, which generates repeated collisions, and re-enable the port when the condition clears. They are also pathways to continued network growth.

**Features:**

- Contains 8 or 16 10BaseT ports.
- Includes an uplink port for cascading multiple 8222s between 10BaseT ports.
- Simplifies set-up via plug and play installation.
- Detects polarity reversal on cables connected to 10BaseT ports.
- Indicates status of power, collisions and connections via LEDs.

### 15.20.4 WIRELESS LAN ADAPTERS

These adapters provide seamless LAN access to any unwired PC. One can even create a LAN among notebook PCs in conference rooms, airplanes - anywhere.

**Features:**

- Uses diffused infrared light. So transmissions are secure and do not have to be aimed.
- Includes cables for external infrared transceivers for communications within a radius of 6 m.
- Provides seamless bridging and roaming support for Token-Ring and Ethernet networks.
- Extends existing LANs via infrared-enabled bridges or routers.
- Supports different device drivers.
- Works with industry-standard computers.
- Provides a 1Mbps data transfer rate.
- Supports IBM LAN Support Program, IBM TCP/IP, Artisoft, LANtastic, Netware, Personal NetWare, NetWare Lite and Windows for Workgroups.

### 15.20.5 FDDI ADAPTERS

The Fiber Distributed Data Interface (FDDI) delivers the bandwidth you need for even the most demanding network applications. Micro Channel, ISA and EISA systems benefit from 100Mbps speed to the desktop—just the capacity you require for today's graphics intensive applications. The newest FDDI Adapters deliver this fast throughput over existing UTP type 5 or FTP copper cabling providing a low cost upgrade to a high performance network.

**Features:**

- Supports ANSI X3T9.5 and ISO 9314 standards.

- Compatible with today's leading operating systems such as DOS, OS/2, Windows, Windows NT, Netware, SFT III and UNIX.
- Provides synchronous frame transmission and bandwidth allocation for multimedia and time critical applications.
- Includes Remote Program Update.

#### 15.20.6 FDDI WORKGROUP CONCENTRATOR

The workgroup concentrator is a low cost hub solution. It works with existing hubs to serve as a high-speed link or backbone.

##### *Features:*

- Links up to 12 devices via fiber as well as shielded and unshielded twisted pair copper connections.
- Extends 8240 functionality to serve as an entry-level FDDI concentrator or "collapsed backbone" for small workgroups or LAN extensions.
- Includes SMT and SNMP network management protocols.

#### 15.20.7 TOKEN-RING ADAPTERS

Token-Ring adapters are available for ISA, EISA, PCMICA, Micro Channel and PCI buses. They offer low price, easy installation, reduced network maintenance costs, and enhanced functionality.

##### *Features:*

- Full duplex enabled so that when attached to a full duplex Token Ring switch, the available bandwidth can be increased to 32 Mbits/sec.
- Support for Ring-Speed Listen that senses the speed of a Token Ring and automatically configures the adapter to 4 or 16 Mbits/sec.
- Software configurable, with graphical installation software to simplify set up.
- Auto media detect that senses the type of media connection and automatically configures the adapter to Unshielded Twisted Pair (UTP) or Shielded Twisted Pair (STP).
- MAC addresses located on the outside of the adapter for quick diagnostics.
- Switchless (no DIP switches or jumpers to set).

#### 15.20.8 ROUTER

Many branch networks need a cost-effective, high performance multi-protocol routing and bridging solution that connects to the main network. A router serves this purpose.

## 15.21 ATM (ASYNCHRONOUS TRANSFER MODE) NETWORKS

Transfer mode defines how information supplied by network users is eventually mapped onto the physical network. It is also a technique used for transmission, multiplexing and switching aspects of a communication network.

According to the architecture and techniques used to transfer data, networks used can be categorized into two. They are:

- (i) Circuit Switched Networks
- (ii) Packet Switched Networks

### Circuit Switching

Circuit Switching is mostly used for telephone networks. Here the bandwidth is multiplexed among the transmitting stations, each having a fixed bandwidth. A circuit is established between the two entities to exchange information for the complete duration of the connection. Each channel has a fixed bandwidth. Several channels can be multiplexed onto a link and translating the incoming channel number to the outgoing channel number performs switching. Before the data can start flowing, a collection of consecutive channels are reserved from source to destination by signaling. Once the circuit is established, the traffic flows continuously during the duration of the connection.

### Packet Switching

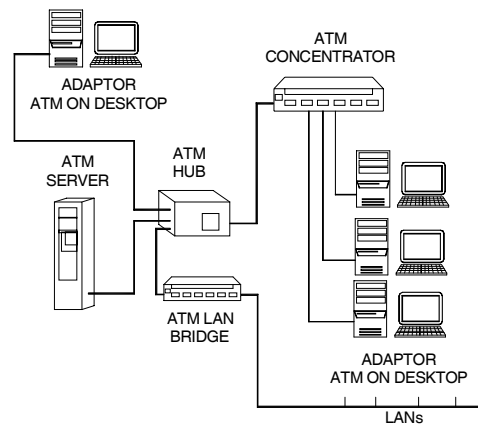
Packet Switching is a scheme in which user messages are segmented into packets before they are transmitted. The size of the packet is restricted to some maximum value. By doing this, reception and transmission of packets of a message can be overlapped, thereby reducing end to end delay of messages. Essentially, each packet in the network is treated as an independent entity. However, they are required to be reassembled at the receiver to form the original information unit before being passed to the user. Early work in supporting real time applications together with data applications in integrated networks was connected in a variant of packet switching known as Fast Packet Switching (FPS).

In the fast packet switching scheme, a packet could be transmitted from an intermediate mode, even before it is completely received, thereby further reducing the end-to-end delay. However, Fast Packet Switching with variable length packets results in complex switching fabric and buffer management schemes, as the transmission speeds increase. Hence they have a ceiling for the bit transfer rates. FPS schemes were modified suitably to support B-ISDN applications. One such instance of the FPS is the Asynchronous Transfer Mode (ATM) shown in Fig 15.12, which provides connection-oriented service employing small, fixed length packets known as cells of size 53 bytes.

### Features:

- The fixed small cell sizes, result in simplified buffer management and switching fabric design. The buffer sizes at the intermediate nodes are expected to be small, thereby bounding the cell delay.

- The connection-oriented nature of ATM provides an efficient means to guarantee the quality of service requirements of applications.
- The ATM header includes minimal functionality. This reduces the intermediate node processing.



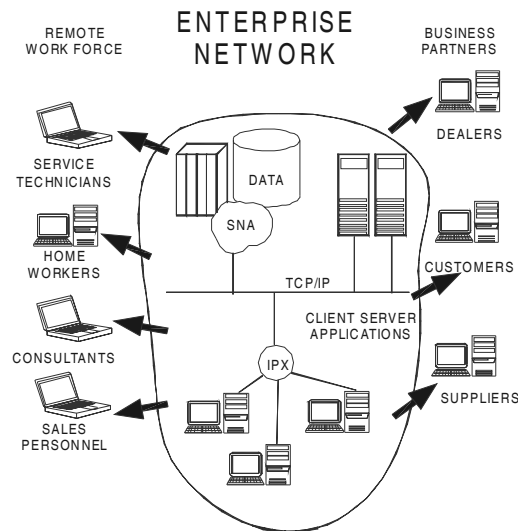
**Fig. 15.12 A Synchronous Transfer Mode**

## 15.22 ENTERPRISE WIDE NETWORK

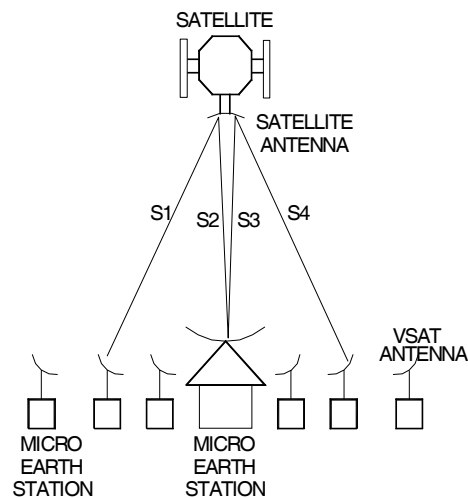
A manufacturing enterprise can function very efficiently if various segments of the enterprise are connected in the form of an enterprise wide network. Within the industry the various users can be connected in the form of a local area network. The manufacturing engineering, business management, purchase, sales etc., can be connected through client/server mode on a TCP/IP backbone. Fig. 15.13 shows a typical enterprise wide network. It can be seen that various business partners like dealers, customers and suppliers can be connected to the network making the flow of information smooth and efficient. The network can also connect service technicians who may be located at different parts of the country or even different parts of the world. The network also facilitates the professionals to log on to the network from their homes. Similarly sales people can have instant access to the company through the network irrespective of their physical location. The information flow can be through electronic mail or through suitable workflow automation software. Workflow automation is discussed in the next section. Through the network the company can reach many professionals and expert services which are located anywhere in the world. An example is quoted in section 15.24.

When the different plants of a company and its associated groups are geographically distributed they can be linked together by VSAT. A VSAT is a Very Small Aperture Terminal, which can communicate with another VSAT through the satellite. Communicating through VSAT is very cost effective and efficient. Fig. 15.14 shows a typical VSAT based communication system. A VSAT system consists of a satellite hub (eight to nine metre

antenna, along with network management switching equipment etc.) and several 1.8m VSAT terminals located at various customer premises. All communication between VSATs take place via the hub, using a geostationary satellite hovering in a stationary orbit. Customers can share facilities of a hub operated by a service provider in their own hub if there are a large number of locations. Typical speed of communication from hub to VSAT direction is 512 kbps and VSAT to hub is 64/128/256 kbps.



**Fig. 15.13 Enterprise-wide Network**



**Fig. 15.14 VSAT-Based Communication System**

## 15.23 DOCUMENT AND WORKFLOW MANAGEMENT SYSTEM

Computer Integrated Manufacturing can reduce paper documents to a considerable extent, apart from improving the communication among various segments involved in manufacture.

Some estimates show that manufacturing industries now consume twice as much paper for document preparation and development as they did a few years ago. That means twice as many documents cross engineer's desk, and twice as many reviews and approvals have to be looked over and forwarded. More seriously engineers have a large number of electronic files to manage too. This means heavy workload for staff. This also results in loss in productivity and accidental errors (overwritten and deleted files, for example).

### 15.23.1 PAPERLESS OFFICE

The introduction of desktop computers led to the use of hundreds of electronic files. This has necessitated the following:

**Better tools for document creation:** Easier ways to create and edit documents mean more documents get produced.

**Archival necessity:** The engineers have to revise, distribute and archive documents (and all their iterations) over many years for many more people. To meet these regulations the engineer must handle and track documents differently than before.

**Lean organizations:** As organizations strive to become more efficient, fewer staff members must manage the same amount of information.

**Shorter business cycles:** Time is money, and today's clients want higher quality, shorter lead times and lower costs than ever before. Companies compete fiercely in regional and global markets. They compete most successfully when they adopt "parallel processing" techniques, when they use resources and manage processes—design, engineering, drafting, manufacturing - concurrently rather than sequentially. The result is more electronic and paper documentation.

**Changes in the means of communication:** If the engineers do not keep up with technological changes, they lose their competitive edge. Ever-faster PCs and printers, faxes, e-mail, network servers and information superhighway are all to be used to speed up engineers' tasks. Today employees generate many more documents. Information is created faster, reviewed by more people, and distributed more widely.

Many manufacturing managers underestimate the negative impact of poor document management on productivity. They believe that existing procedures provide adequate security and that finding documents is a "nuisance" rather than a serious threat to productivity. However, mismanaged files may cause significant delay in project completion.

Manual procedures developed to manage paper drawings are simply inadequate for electronic documents - no matter how small or large the manufacturing company is. In

fact, small companies probably pay an even higher price for ineffective document management than their larger competitors. Smaller companies cannot absorb the extra costs that result from mismanaged documents and workflow. They have fewer employees to handle a crisis and fewer cash reserves for overruns. And they more quickly lose their competitive edge when poor security leads to error.

### 15.23.2 MANAGING DRAWINGS ELECTRONICALLY

If the manufacturing engineer has a computer, he can manage drawings electronically. But he needs a document management system to do it - one that lets him maintain, access and manipulate drawings and related information quickly, securely, cost effectively. A quality document management system can:

- Display document information on custom electronic “file” cards.
- Organize drawings and related documents into folders that can be restructured without physically moving files.
- List all drawings and related documents currently being worked on by anyone of the staff.
- Ensure that drawings and related information can be easily located and search parameters saved for future use.
- Make document “behaviour” user definable.
- Store all drawings and related documents in a secure, central location.
- Monitor authorization and access rights to maintain security.
- Automatically back up selected (or all) drawings and related documents.
- Automate workflow by automatically routing drawings, related documents and instructions/messages to all relevant staff - from approvers to reviewers to managers - and tracking individual responses and revisions.

### 15.23.3 THE FUNDAMENTALS OF TECHNICAL DOCUMENT MANAGEMENT

A viable document management system helps the manufacturing engineer to find the files he needs. It makes it easy to find out what is in them and lets him edit them with the program appropriate to the job. It should have the organization and access features and benefits described below:

- **Flexible organization:** A single, fixed document organization is not adequate. Electronic document must often appear in more than one “folder”, but one does not want to duplicate files. The system should organize documents into folders that can be reorganized at any time without physically moving documents. The best systems group documents dynamically by specific tasks, projects or design phases. Users can change these groupings to view documents in the format appropriate to their task. For example, the team leader might view information organized by discipline and document type, whereas the designer prefers project and plot sheet.

- **Document types:** File types, typically indicated by a file extension (.DBF, .DWG, .TXT, .DOC, .DXF etc.) are inadequate for organizing and managing electronic documents. An effective document management system lets the user define document types that relate to the work you do. For example, AutoCAD files might be differentiated into Plans, Sections and Elevations (AEC) or Assembly and Part (Mechanical). Each document should have a specific program associated with it for editing, viewing, redlining or printing.
- **Document names:** An effective document management system should let the engineer use longer, more meaningful file names and view them from within his applications.
- **Easy to access profile information:** The user should be able to quickly and easily view document name, author, creation and revision dates, revision number, and a list of related documents. He should be able to modify profile information at any time and to save custom information with each document and each revision. All documents checked out to a user should be displayed in a single list.
- **Document search capability:** Searches of the common document storage area should allow the user to obtain a list of documents meeting specific criteria. One need not have to know complex query parameters or Structured Query Language (SQL) commands to complete these searches. One should be able to define and save common searches and rapidly access them through dialog boxes, scrolling lists and user intuitive sequences. More complex searches with prompts should still be easy to create and save, so that less-experienced staff can run them.
- **Document security:** For some companies, “document security” means carefully restricting access to sensitive information - financial reports, sales plans, personnel data. But designs and drawings are corporate assets, too, and should be secured from inadvertent deletion or overwriting. The engineers may also need to ensure that unqualified people does not edit design documents.
- **Managing documents—Revisions:** To avoid user confusion and error, a document management system should automatically save and sequentially number all revisions. It should limit on-line revisions by automatically archiving or deleting earlier versions.

Information associativity: When a drawing is revised, the document manager should distinguish which associated documents should be linked to the new release, and which, to the original.

Quick comparison: Occasionally one will want to compare two revisions of a drawing. With a “compare” feature, the document management system visually highlights the differences between two files, so one can easily choose the right one.

- **Document viewing:** Any document management system should include extensive, quickly generated, built in viewing capabilities.
- **Multi-format viewing:** The system must handle all the documents with which one works. For each file type, one should be able to view, search and print



documents - even if one does not have immediate access to the application with which they were created. And if the software cannot handle a particular format, adding a third party viewer application for that format should be an easy job.

- **Thumbnails:** Some systems provide a thumbnail of each document so one can instantly see what it is, regardless of format.
- **Redlining:** Redlining lets the user correct or comment on a drawing without changing the drawing itself. Redlining also allows non-CAD oriented users to easily pass comments to design. However, a red line file must be a separate file, and the document management system must track the relationship between the original and the red line.

#### 15.23.4 AUTOMATING WORKFLOW

Workflow automation should help the manufacturing engineer share and route documents in the manner best suited to the team. It must be tightly linked to the system's document management features and facilitate the adhoc interactions common in the design process.

A workflow automation system should provide electronic document routing, alerts, automatic event notifications and electronic approvals.

The following attributes are required for a document management system:

- **Sharing of information:** Successful workflow automation begins with clear system procedures and easy-to-use communication and information sharing processes. As a standard feature, the system must provide task routing with all relevant documents attached.

For example, an action slip, with documents attached, is routed to the team, recipients see it on e-mail, and the system tracks responses. The system should allow the user to route work requests to predefined teams. Thus, a project manager creates a change order, attaches the relevant drawing, and routes it as needed.

- **Alerts:** The team leader or other user can specify the sequence of individuals for edit or review of a series of documents. When team members do not respond within a given time, the system should alert the message originator and the person responsible for the delay.
- **Approvals:** An electronic approval system allows supervisory staff to approve designs and changes rapidly, eliminating the delays inherent in paper-based approval loops. The software should not only route documents for approvals, but also automatically designate a document as "approved" and alter the revision number. Usually, several team members review and comment on different project phases allowing them to work with the same documents, compiling individual comments, and updating associated documents. Since these actions are performed electronically, the traditional paper file is no longer necessary.

- **Event notification:** A tightly integrated workflow automation and document management system can notify the user when certain changes are made to a document. For example, a manager may want to know when someone checks out a specific document for editing. An engineer may want to be notified when a component or assembly drawing has been modified. You should be able to configure this kind of event notification to work on specific documents, for a variety of events, and to notify either single users or entire groups.

A good technical document management and workflow automation system must be easy to use. The following are the attributes of a good system:

- **Transparent user operations:** Software with a friendly user interface means less time to train employees.
- **CAD software integration:** The document management and workflow automation software should function as an extension of the CAD system, not as a separate application. This improves productivity.
- **Bulk downloading:** Whether one needs to access entire projects or electronic libraries of details or parts, he/she should be able to easily import large numbers of documents into the system.
- **System performance:** All computerized document management and workflow automation systems use a database “engine”. This responds quickly to user requests.

Response times depend on many factors - for example, network performance capabilities, number of users simultaneously accessing the database and re-indexing speed. Background processing can also significantly affect system performance.

### 15.23.5 ADVANTAGES OF WORKFLOW MANAGEMENT SYSTEMS

#### i. Individual Productivity:

Every person on the team using a document management and workflow automation system will become more productive. For example, the new system will eliminate manual searches for files when edits must be made. Check-in/check-out features will guard against accidental overwrites and unintentional revisions.

#### ii. Increase in Team Productivity:

The typical design process has several phases. In every phase, documents are continuously created, reviewed and revised. A document management and workflow automation system reduces rework and shortens review cycles. It improves communications and helps the member of the team to easily find drawings and other files. The review cycle is shorter because you route documents to several people at once rather than to one person at a time.

A document management and workflow automation system will also affect the way the team manages design changes. Changes made early in the design process are inexpensive to implement and vice versa. Indeed, late changes can upset the whole project

schedule. Yet in most companies, design changes increase as the project nears completion. These changes are incorporated incurring substantially high costs. Any tools that help your team make changes earlier generate savings.

Thus Workflow automation software is an enabling tool for concurrent engineering.

#### **15.24 A CASE STUDY OF APPLICATION OF GLOBAL NETWORKING**

There are a number of success stories of application of use of computer networks for product development and modification. The following example of application of concurrent engineering appeared in *Industrial World*, July 3, 1995.

This story is related to the product development in a company called VeriFone Inc., Redwood city, California, and a maker of transaction automation equipment. Their operations are such that on a typical project a software engineer in Hawaii might collaborate with mechanical engineers in California and Taiwan and printed circuit board designers in Paris. They have a strong packaging design group in Taiwan and if a complicated enclosure is to be designed they get it done in Taiwan. The activities are thus allocated to the sites where strength exists.

Rather than having the different development centers work on their own specific projects, VeriFone brings a number of the globally dispersed sites into the development of each new product. With Global networking geographic distances can be turned into a competitive advantage. For e.g. VeriFone has a development centre in Bangalore, India, to take advantage of the high quality engineering manpower available in this region and one in Paris to gain access to European technologies.

Even time difference between locations can be an advantage to respond to request for design changes. For example, when an engineer who works in Hawaii receives an urgent request later in the day he will send it immediately to Bangalore or Taipei where it is earlier in the day. The person who receives the request can access the related CAD files, make the necessary changes and send the design changes back to the person who has requested it. Depending upon where the person lives the new design is available at the start of his next working day.

With this global approach VeriFone has cut short its product development cycle down to as short as seven months to complete the project. The key to making development work globally is a highly effective communication system, which includes a computer network and video conferencing.

The technological foundation of VeriFone's global development strategy is an extensive computer network. VeriFone has a gateway to the internet and users can log onto the computer system from anywhere in the world via CompuServe. A Motif based program gives every engineer regardless of location, access to every file in the company. The network supports the company's E-mail system, which is the main form of communication at this company. Through E-mail any employee can reach any other employee in the entire

company instantaneously, Customers also use E-mail for communication. Videoconferencing is another technology to foster international communication. Rarely will all engineers on a particular project gather in the same room, but they will meet from time to time in a videoconference.

### QUESTIONS

1. Discuss the need and advantages of networking in a manufacturing shop.
2. Differentiate between LAN, MAN and WAN.
3. What are the different components of a LAN?
4. Describe different interfaces used in transmitting signals.
5. Explain the working of a modem.
6. Describe the three basic network topologies.
7. Explain the functions of each layer in ISO-OSI.
8. Describe the salient features of MAP and TOP.
9. What are the commonly used network interface cards?
10. Study a LAN and prepare a brief report on the functions of a network operating system.
11. Discuss how you will carry out a design in a networked environment.
12. Study a manufacturing shop and prepare a document on networking the computer related equipment on the shop floor.
13. How does a network help design activity where a large number of engineers are involved?
14. What are the requirements of an enterprise wide network?
15. How does workflow automation software help to improve team productivity?
16. What are the advantages of using workflow automation software?
17. Why is VSAT an essential tool for a CIM company?
18. How will you use internet to advantage to implement CIM?

**This page  
intentionally left  
blank**

# COLLABORATIVE ENGINEERING

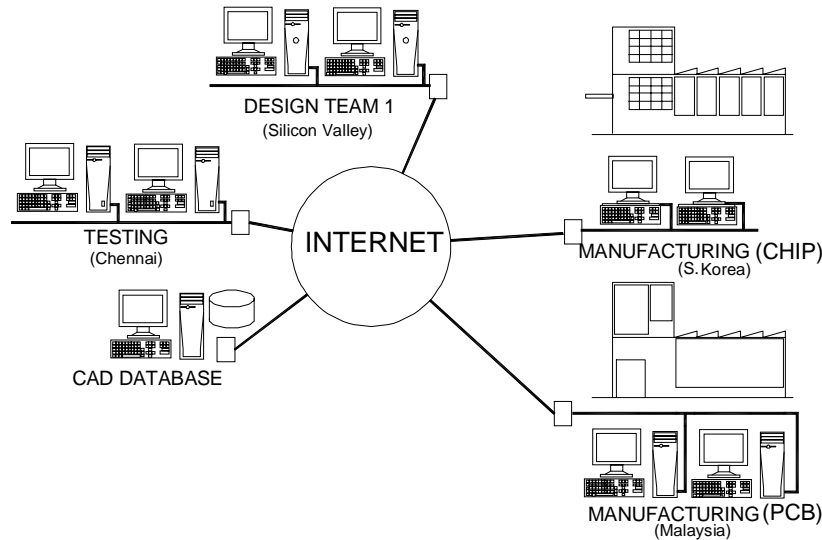
*World Wide Web and Internet have brought about significant changes the way engineering design and manufacturing activities are being carried out. It is now possible for different teams to work together on diverse platforms in geographically distributed locations and complete the product design and development efficiently. The technologies evolving that make this possible are discussed in this chapter.*

## 16.1 INTRODUCTION

Large engineering projects involve co-ordinated work of hundreds of engineers working in small or large teams. Computer integrated manufacturing environment makes this possible because of the possibility of data transfer between different applications. However, to day the necessity to collaborate between teams working in places far apart has arisen. For example, the design of an add on board for a new generation computer may be carried out in the Silicon Valley, USA. The engineers working in the development group generate the product data. The testing may be undertaken at Chennai. The product data is transferred via Internet to the manufacturing company in South Korea to make the chips. The printed circuit board may be made in Malaysia. A firm in Singapore may assemble the product. This is shown in Fig. 16.1. The members in entire team involved collaboratively work using the Internet.

On the face of it may appear to be a sequential task. In reality Intranet and Internet permit the design, manufacturing and testing teams to collaborate during the development phase itself so that the product can be introduced in the market as early as possible. The company can also share the design data with the prospective users long before the product is manufactured. For example, let us assume that a company is developing 40 GB disc drives. Long before the product is launched in the market the manufacturer can pass on the data on this disk drive so that the computer manufacturers can start developing new computers with this disk drive. As soon as the disk drive is made available, new computers can

incorporate the same. In addition the designers, manufacturers and the customers can collaborate effectively to develop a product, which meets the customer's performance and quality requirements. This collaboration can be both interdepartmental and intradepartmental.



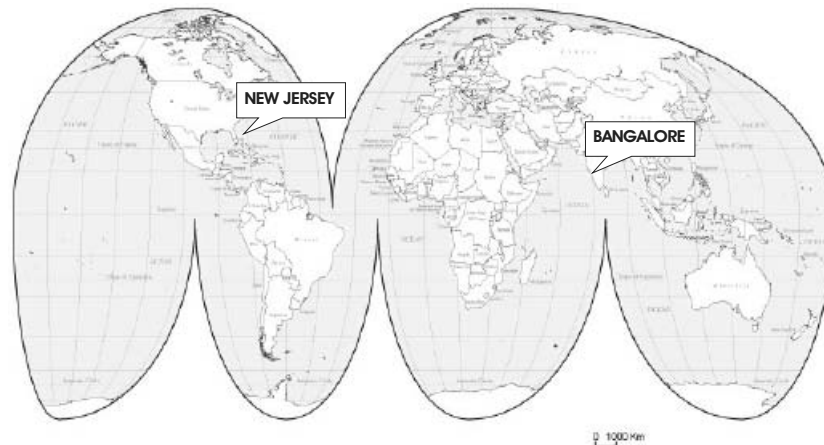
**Fig. 16.1 Collaborative Product Development Scenario**

Several consulting groups have developed collaborative engineering environments, which provide design engineers the ability to better understand the cross discipline effects of design changes, operations changes, budgetary limitations, and new technology adoption. These integrate various engineering disciplines into one centralized fully distributed product data management system that encompasses numerous applications and stand-alone legacy tools. In the case of aerospace engineering, such environments integrate disciplines such as launch trajectory analysis, vehicle sizing, thermal analysis, structural analysis, costing, dynamics and controls, kinematics, and instrumentation operations.

## 16.2 FASTER DESIGN THROUGHPUT

The need for reducing product development time was highlighted in different sections of this book. The collaborative product development scenario emerging to day can reduce this lead-time. For example, let us assume that there are two product teams one at New Jersey and another at Bangalore. A part of the design is carried out in New Jersey during the day. At the end of the day the files are transferred to Bangalore where the design engineers will have just started the day's work. The engineers at Bangalore can then continue

the work and at the end of the day's work transfer the data and files back to New Jersey. More groups at different locations also can work in collaboration. One significant advantage is the time compression in product development. Figure 16.2 illustrates this collaborative design scenario.



**Fig. 16.2 Collaborative Design Scenario**

The Internet facilitates not only product development environment but also many other associated tasks. For example, let us consider product support. The support division can route the service request from a customer to any of the support groups, which may be strategically located in different parts of the globe. At any point of time it will be possible to download the task to one group and they can study the customer requirements and come with a solution even though the support group may be located in another continent thousands of kilometers away. This eliminates the delay and the customer gets immediate service.

### 16.3 WEB BASED DESIGN

The World Wide Web is emerging as a good facilitator of design. One of the primary requirements of designers is the necessity to access standards and standard parts. In the past, manufacturers used to supply the CAD models of standard components in floppy's and CD-ROMS. This has the disadvantage that the data and part models need to be updated frequently. To day this information can be directly accessed from the Internet. There are several web sites from which designers can download commercially available parts. Many provide cross-referenced supplier catalogues so that the designer can have a choice of different manufacturers. Unlike in the past, the CAD models in 2-D or 3-D are available. The designer can also contact the suppliers and obtain price and delivery details through



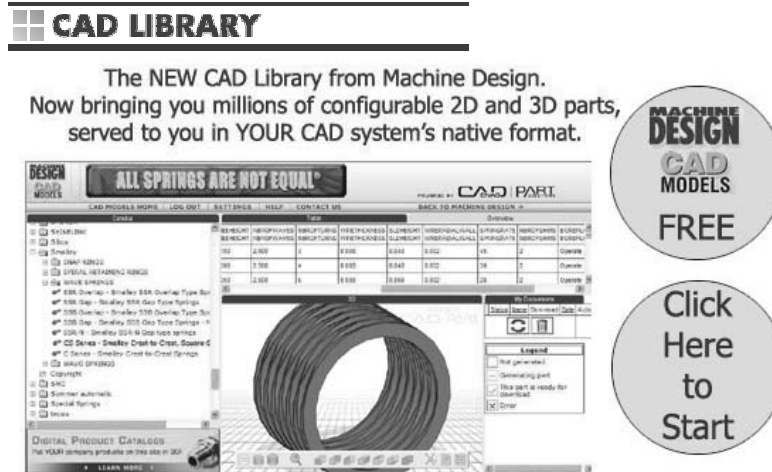
the Internet. The right choice can thus be made. Since the CAD models can directly be incorporated in the assemblies, considerable savings in design time can be effected and some of the likely errors in designs can be avoided.

Several such web sites are available now. Some of them are:

[www.cocreate.com](http://www.cocreate.com)

[www.machinedesign.com/cadlibrary](http://www.machinedesign.com/cadlibrary)

PTC Online Parts Catalog also provides a variety of parts from several manufacturers. CAD part libraries are available in several other websites. These web sites and manufacturers provide access to several lakhs of components with millions of product data. Figure 16.3 shows a popular web site.



**Fig. 16.3** [www.machinedesign.com/cadlibrary](http://www.machinedesign.com/cadlibrary)  
(Courtesy: Machine Design)

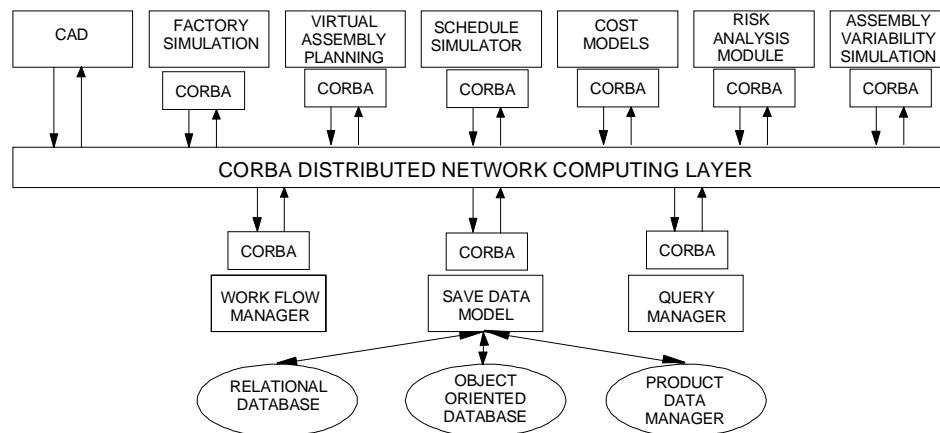
## 16.4 CHANGING DESIGN APPROACHES

Apart from the need for reducing lead-time the design engineers have to meet several other requirements. Cost is one such factor. Even before the design starts the cost is specified and the design team has to ensure that the product cost is contained. The design changes are to be limited to a minimum if not entirely avoided. Scrap is to be reduced and rework is to be limited to the minimum.

Another important aspect of design is the decision-making. Several design alternatives may be available, each with its associated risk. Therefore risk analysis forms an essential part of design process. Softwares are available to carry out risk analysis.

Collaborative product development requires the integration of a broad range of

tools across a variety of platforms. The important activities like design, virtual assembly planning, cost estimation, factory simulation, scheduling, quality assurance, risk analysis, etc are carried out using different software tools. It is therefore necessary to have a single collaborative environment. Several initiatives have been reported to achieve this. One such environment is shown in Fig. 16.4. Here the data transfer from various applications is achieved through the use of CORBA (Common Object



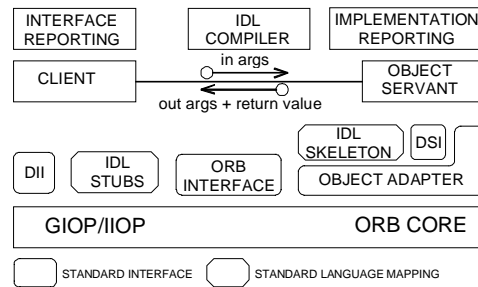
**Fig. 16.4 Collaborative Product Development Environment**

Request Broker Architecture) or COM/DCOM. The different databases are linked to the applications through the CORBA distributed network-computing layer. A workflow manager ensures systematic product data management including change management. A query manager enables the designer's data access from databases as well as applications. This type of development environment is used by several organizations now. The advantage is that the communication is transparent across different platforms, operating systems, and programming languages. The Internet enabled applications make this approach very effective to reduce product development time as well to evolve a more robust product.

### 16.4.1 CORBA

The Common Object Request Broker Architecture (CORBA) is an open distributed object computing infrastructure being standardized by the Object Management Group, which is an international not for profit consortium. CORBA automates many common network programming tasks.

Figure 16.5 illustrates the primary components in the CORBA ORB architecture. Descriptions of these components are given below:



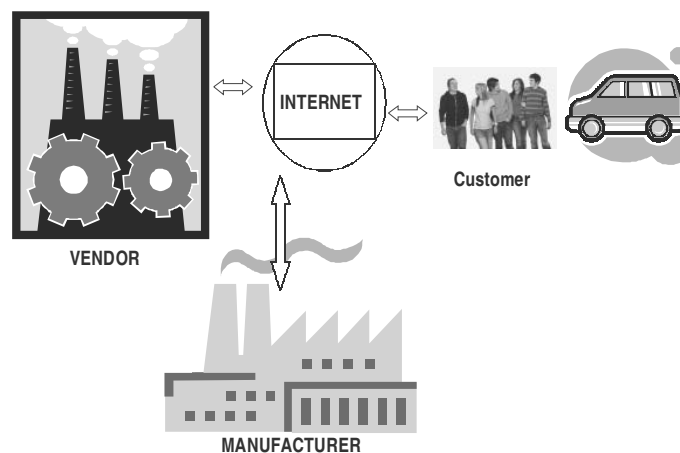
**Fig. 16.5 Components of CORBA ORB**

- **Object:** This is a CORBA programming entity that consists of an *identity*, an *interface*, and an *implementation*, which is known as a *Servant*.
- **Servant:** This is an implementation programming language entity that defines the operations that support a CORBA IDL interface. Servants can be written in a variety of languages, including C, C++, Java and Smalltalk.
- **Client:** This is the program entity that invokes an operation on an object implementation. Accessing the services of a remote object should be transparent to the caller. Ideally, it should be as simple as calling a method on an object.
- **Object Request Broker (ORB):** The ORB provides a mechanism for transparently communicating client requests to target object implementations. The ORB simplifies distributed programming by decoupling the client from the details of the method invocations. This makes client requests appear to be local procedure calls. When a client invokes an operation, the ORB is responsible for finding the object implementation, transparently activating it if necessary, delivering the request to the object, and returning any response to the caller.
- **ORB Interface:** An ORB is a logical entity that may be implemented in various ways (such as one or more processes or a set of libraries). To decouple applications from implementation details, the CORBA specification defines an abstract interface for an ORB. This interface provides various helper functions such as converting object references to strings and vice versa, and creating argument lists for requests made through the dynamic invocation interface described below.
- **CORBA IDL Stubs and Skeletons:** CORBA IDL stubs and skeletons serve as the “glue” between the client and server applications, respectively, and the ORB. A CORBA IDL compiler automates the transformation between CORBA IDL definitions and the target programming language. The use of a compiler reduces the potential for inconsistencies between client stubs and server skeletons and increases opportunities for automated compiler optimizations.
- **Dynamic Invocation Interface (DII):** This interface allows a client to directly access the underlying request mechanisms provided by an ORB. Applications use the DII to dynamically issue requests to objects without requiring IDL interface-specific stubs to be linked in.

- **Dynamic Skeleton Interface (DSI):** This is the server side's analogue to the client side's DII. The DSI allows an ORB to deliver requests to an object implementation that does not have compile-time knowledge of the type of the object it is implementing. The client making the request has no idea whether the implementation is using the type-specific IDL skeletons or is using the dynamic skeletons.
- **Object Adapter:** This assists the ORB with delivering requests to the object and with activating the object. More importantly, an object adapter associates object implementations with the ORB. Object adapters can be specialized to provide support for certain object implementation styles.

## 16.5 EXTENDED ENTERPRISES

The use of Internet has made the communication between the vendor, manufacturer and the customer more effective. Figure 16.6 shows how concept of extended enterprises in which there is a tight integration between the supplier (vendor), manufacturer and the customer. The manufacturer can know exactly what the customer wants. On the other hand the manufacturer lets the customer know about the product while it is designed so that the requirements of the customer could be incorporated in the early phases of the design itself. This will eliminate costly redesign later. Similarly, the manufacturer is in close touch with the vendors during the product development stage. The design details are communicated to the vendor through CAD models so that the vendor can study not only the feasibility of manufacture but also come up with a realistic quote. The vendor may also suggest modifications. In many cases vendor himself will provide the CAD model of the part or the sub-assembly to be used in the product. In many cases the vendor will have the responsibility of absorbing the increase in material or labour cost. The participation of the vendor in the design process is therefore very critical.



**Fig. 16.6** Extended Enterprise

## 16.6 SOFTWARE FOR COLLABORATIVE DESIGN AND ENTERPRISE-WIDE PRODUCT VISUALIZATION

Many CAD/CAM packages provide facilities for collaborative design.

Dassault System's Component Application Architecture (CAA V5) provides the IX SPeeD V5 suite, making it a natively interoperable and collaborative solution for the CATIA(R) V5. This new product suite includes add-on modules for specialized design requirements to address an extended product development cycle. With IX SPeeD V5, companies manufacturing consumer goods, electronics and electrical (E&E) can take advantage of the power and flexibility of its functional design approach. This power and flexibility is derived from ImpactXoft's innovative method of capturing the design behavior as functional features. This makes it easier to create, interpret, edit and reuse designs across the extended enterprise. A feature of the Dassault System's software is the instant participation feature for collaborative design within the CAA V5 environment. Instant participation's collaborative capabilities allow OEMs and suppliers to not only communicate design changes, but also to share and merge elements of their product designs at anytime, from anywhere, and with anyone working on the project. Functional modeling and simultaneous product development approach to solving design problems within a global development environment raises the bar for innovative 3D design and collaboration capabilities.

Collaboration can be synchronous or asynchronous. A synchronous collaborative CAD solution is usually hosted on an application server provider (ASP) form. CoCreate's OneSpace is the first such application to appear. PTC's Pro/Collaborate provides asynchronous collaborative capability. Some of the other software for collaborative design include Teamcenter, Cimatron, Fullscope and Matrix One.

Another typical example of collaborative design is that of Swedish automobile manufacturer Volvo. Volvo's collaborative design system was built using Centric Innovation software from San Jose-based Centric Software Inc. The software is integrated with Volvo's computer-aided design and manufacturing (CAD/CAM) systems and is used to evaluate alternative vehicle designs and conduct project reviews online, as opposed to building physical mock-ups of prospective vehicles. The system tracks design changes and notify engineers whose specifications are affected by those alterations. The Centric system will also help tackle the complex challenge of pulling data from different CAD/CAM systems and then updating those changes across the systems. Volvo currently uses three different types of CAD/CAM systems for different phases of the vehicle conceptual design process.

Digital manufacturing systems with advanced 3-D simulation, virtual reality, and collaborative product lifecycle management (PLM) software tools are helping manufacturers accelerate the design and build cycles of new products, while lowering production costs and boosting plant efficiencies.

With digital manufacturing solutions, several manufacturers in aerospace and

automotive have implemented cutting-edge virtual factory systems that allow greater re-use of engineering data, better control of late engineering changes in the design cycle, and more sophisticated simulations of NC machining processes and factory-floor layouts.

As far as aircraft industry is concerned, Boeing 777 is said to be one of the earliest projects that was done as a fully digital mockup. With the 787, Boeing is trying to go to a complete PLM environment using CATIA for design, Enovia for data management and lifecycle management, and Delmia for the manufacturing applications. Lockheed Martin Aeronautics Co. also has used digital manufacturing in its Joint Strike Fighter (JSF) program. It is deploying Delmia's simulation software to assist in analyzing its abilities to produce and support the aircraft. Lockheed Martin uses Delmia simulation tools to identify potential collisions in machinery, tooling, and fixtures at the tightly packed, assembly plant in Fort Worth, Texas where the planes will be built. Engineers are using the tools to determine accessibility of spaces inside the airframe and workflow of parts and people with Delmia's Ergo human simulation software that analyzes ergonomic issues.

With collaborative 3-D modeling and simulation, software solutions like Delmia and Tecnomatix provide a data model beneath all the applications, which ensures all the data entered in any one of those disciplines is made available for the other applications to enhance and leverage the data. This facilitates different team in creating and optimizing their sets of data. The customers and vendors also need not search for the most accurate, up-to-date data. This kind of a collaborative environment provides data that are always accurate, current and accessible. Thus manufacturers can leverage data collaborations in CAD, machining data with CAM systems, and 3-D simulations on the factory floor and in factory process planning.

Enterprise-wide product development may involve the use of software packages on diverse platforms and different database software packages. To leverage their investment in the design and database technology, more and more large manufacturing companies are using visualization.

The reduction of product development time necessitates that all members of a design team must be capable of visualizing the product as it is being evolved. Team members may be designers within the company or from the vendors. Many will be using different software packages. The visualization software enables the users to easily view, analyze, and collaborate on complex visual products in a single visual environment. Viewing product information in context with the complete visual model is critical to improve communication across all departments of a company. Users can interact with a complete product- whether it is a passenger car, airplane or a machine tool or zoom in on a single small part and determine its associated design, manufacturing, and cost or supplier information. Using standard Web browser and simulation software, engineers and designers from around the world can quickly access the latest product databases to interactively view large models in a single visual environment. The real time collaboration capabilities of these softwares bring designers together in one interactive session, enabling them to quickly identify and resolve issues before costly redevelopment efforts are necessary. This collaboration is also an effective way to present and review the products with customers and suppliers.

**QUESTIONS**

1. Discuss how Internet is an enabling tool for collaborative product development.
2. Describe how World Wide Web can help to shorten the product development cycle time.
3. What are the benefits of collaborative product development?
4. Discuss the significance of enterprise wide product visualization.

# CHAPTER

---

# GRAPHIC STANDARDS

# 17

*The need for portability of the geometric model among different hardware platforms has led to the development of device independent graphics. Simultaneously standards for the exchange of drawing database among software packages have been evolved to facilitate the integration of design and manufacturing operations.*

## 17.1 INTRODUCTION

The heart of any CAD model is the component database. This includes the graphics entities like points, lines, arcs, circles etc. and the co-ordinate points, which define the location of these entities. This geometric data is used in all downstream applications of CAD, which include finite element modeling and analysis, process planning, estimation, CNC programming, robot programming, programming of co-ordinate measuring machines, ERP system programming and simulation.

In order to achieve at least a reasonably high level of integration between CAD, analysis and manufacturing operations, the component database must contain:

- i. Shapes of the components (based on solid models)
- ii. Bill of materials (BOM), of the assembly in which the components are used.
- iii. Material of the components
- iv. Manufacturing, test and assembly procedures to be carried out to produce a component so that it is capable of functioning as per the requirements of design.

In designing a data structure for CAD database the following factors are to be considered:

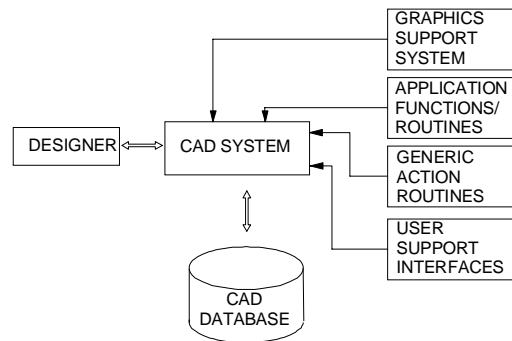
- i. The data must be neutral
- ii. The data structure must be user-friendly
- iii. The data must be portable.

In order to achieve the above requirements, some type of standardization has to be followed by the CAD software designers. The basic elements associated with a CAD system are:



- Operator (user)
- Graphics support system
- Other user interface support system
- Application functions
- Database

A diagrammatic presentation of these elements is given in Figure 17.1



**Fig. 17.1 CAD System**

The reasons for evolving a graphic standard thus include:

- Need for exchanging graphic data between different computer systems.
- Need for a clear distinction between modeling and reviewing aspects.

## 17.2 STANDARDS FOR GRAPHICS PROGRAMMING

Attempts to develop a graphics standard resulted in the following developments in 70's:

- A Graphic Standards Planning Committee (GSPC) was formed in 1974 by ACM-SIGGRAPH (Association of Computing Machinery's Special Interest Group on Graphics and Interactive Techniques).
- A committee for the development of computer graphics standard was formed by DIN in 1975.
- IFIP organized a workshop on Methodology in Computer Graphics in 1976.
- A significant development in CAD standards is the publication of Graphical Kernel System (GKS) in 1982.

## 17.3 FEATURES OF GKS

**GKS (Graphical Kernel System)** is an ANSI and ISO standard. **GKS** standardizes two-dimensional graphics functionality at a relatively low level. The primary purposes of the standard are:

- To provide for portability of graphics application programs.
- To aid in the understanding of graphics method by application programmers.
- To provide guidelines for manufacturers in describing useful graphics capabilities.

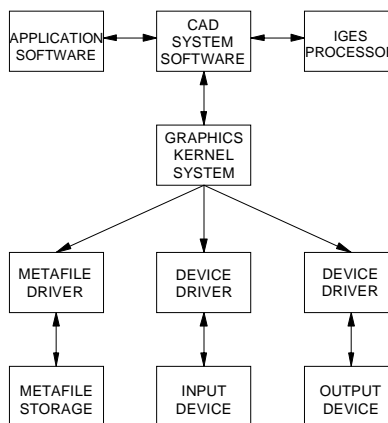
The **GKS** (ANSI X3.124-1985) consists of three basic parts:

- An informal exposition of contents of the standard, which includes such things as positioning of text, filling of polygons etc.
- A formalization of the expository material outlined in (i) by way of abstracting the ideas into functional descriptions (input/output parameters, effect of each function etc.).
- Language bindings, which are the implementations of the abstract functions, described in (ii) in a specific computer language like FORTRAN, Ada or C.

Figure 17.2 shows the GKS implementation in a CAD workstation. The features of GKS include:

- Device independence: The standard does not assume that the input or output devices have any particular features or restrictions.
- Text/Annotations: All text or annotations are in a natural language like English.
- Display management: A complete suite of display management functions, cursor control and other features are provided.
- Graphics Functions: Graphics functions are defined in 2D or 3D.

The drivers in GKS also include metafile drivers. Metafiles are devices with no graphic capability like a disc unit. The GKS always works in a rectangular window or world co-ordinate system. The window also defines a scaling factor used to map the created picture into the internal co-ordinate system of GKS called normalized device co-ordinates. Windows and view ports can then work in this co-ordinate system.



**Fig. 17.2 GKS Implementation in a CAD Workstation**

GKS offers two routines to define the user created pictures. They are primitive functions and attribute functions. Examples of primitive functions are:

- POLYLINE to draw a set of connected straight-line vectors
- POLYMARKER to draw a set of markers or shapes
- FILL AREA to draw a closed polygon with interior fill
- TEXT to create characters
- GDP (Generalized Drawing Primitive) to specify the standard drawing entities like circle, ellipse etc.

The attribute functions define the appearance of the image e.g. color, line-type etc. Current level of GKS is GKS-3D, which provides several other functions. GKS-3D is an extension to GKS, which allows the production of 3-D objects.

#### 17.4 OTHER GRAPHICS STANDARDS

The Graphics Standards Planning Committee (GSPC) of ACM-SIGGRAPH proposed the CORE system in 1977 and revised it in 1979. Though the development of GKS has been influenced by the CORE system, there are a number of significant differences between the two. However, the core graphics have a number of problems at the level of program portability. From a technological point of view, the GSPC CORE has been eclipsed by the development in GKS.

#### 17.5 PHIGS

PHIGS (Programmer's Hierarchical Interactive Graphics Standard) includes in its functionality three dimensional output primitives and transformations. It has dynamic control over the visual appearance of attributes of primitives in a segment. The PHIGS standard defines a set of device-independent logical concepts. Application programmers can use these concepts within a set of PHIGS rules. The major concepts are the Logical Input Device, PHIGS structure, Structure Networks, Structure Manipulation, Search and Inquiry, Structure Traversal and Display, the Name Set mechanism, the viewing pipeline, and the PHIGS workstation.

PHIGS, a programming library for 3D graphics, was developed and maintained by ISO. It is most commonly used on the X Windows system. The PHIGS high level graphics library contains over 400 functions ranging from simple line drawing to lighting and shading. Before displaying a picture, the application first stores its graphics information in the PHIGS graphic database. Therefore PHIGS is referred to as a display list system. The application then appears on one or more display devices and then passes the list to them.

### 17.5.1 STRUCTURE NETWORKS

Structure networks are formed through a relation among various structures in the centralized structure store (CSS). Structure networks are hierarchical and acyclic. This means that structure networks are formed through invocations of other structures in the CSS.

### 17.5.2 LOGICAL INPUT DEVICES

PHIGS allows graphics input for applications programs via six classes of logical input devices, each of which delivers graphics data. These are listed below:

Locator	:	returns a point in world co-ordinates.
Stroke	:	returns a list of points the work coordinates.
Valuator	:	returns a real value in a settable range.
Choice	:	returns an integer between 1 and a certain value n
String	:	returns a character string.
Hierarchical pick	:	returns a reference to a picked primitive.

These conceptual devices are not linked to specific hardware. i.e., the same tablet can be used to realize different devices such as locator and a hierarchical pick. All of these devices are similar to those of Graphics Kernel System (GKS) except for the hierarchical pick. This is unique to PHIGS.

### 17.5.3 STRUCTURE MANIPULATION

A structure can be deleted invoking a function called DELETE STRUCTURE. Once this function has been executed the entire structure is wiped out from the CSS. Another function DELETE STRUCTURE NETWORK wipes out the whole structure network from the point it has been referenced.

### 17.5.4 SEARCH AND ENQUIRY

PHIGS has functionalities for interrogating the CSS for determining the element contents and its characteristics. The complete details of a specified structure element can be determined by calling functions like INQUIRE ELEMENT TYPE AND SIZE and INQUIRE ELEMENT CONTENT. Functions such as INQUIRE PATHS TO ANCESTORS and INQUIRE PATHS TO DESCENDANTS can determine the relationship of a structure to other structures in the CSS. The ELEMENT SEARCH function allows searching within a structure for a particular element type or one of a set of element types. The INCREMENTAL SPATIAL SEARCH (ISS) allows a structure network to be searched for the next occurrence of a graphical output structure element, which satisfies the specified search criteria. Search paths do the referencing of the start-point and found-point.

### 17.5.5 STRUCTURE ARCHIVAL AND RETRIEVAL

An archive file is a medium for storing structure definitions.

Functions like ARCHIVE STRUCTURES (or STRUCTURE NETWORKS), RETRIEVE STRUCTURES (or STRUCTURE NETWORKS), DELETE STRUCTURES (or STRUCTURE NETWORKS), etc. are available in PHIGS for archiving structures (or its networks) into an 'archive file' from the CSS, or retrieving it from the file itself, respectively. The relationship of a structure with other structures is determined by the path functions.

### 17.5.6 STRUCTURE TRAVERSAL AND DISPLAY

Traversal is an operation used to describe a method of structure element processing. The traversal of a network leads to the display of graphical output from the structure network at each workstation to which it is posted. The traversal process interprets each structure element in the structure network sequentially starting at the first element at the top of the network. Any change to the posted structure network triggers a re-traversal of the structure network so that the changes are processed immediately.

### 17.5.7 GRAPHICAL OUTPUT

The graphical output of PHIGS is built up from 'output primitives' and 'primitive attributes'. Output primitives are generated from structure elements by structure traversal. A representative cross-section of these are: Polyline, Polymarker, Text, Fill Area, Fill Area Set, Cell Array, Generalized Drawing Primitive (GDP), B-splines, and NURBS. Text, Fill Area, Fill Area Set, and Cell Array are 'planar primitives' in arbitrary planes. Conceptually these planes have two sides and zero thickness. The viewing transformation determines which side of these primitives is seen.

The discussion on the GKS and PHIGS is to make the reader aware of the developments that led to the present status of computer graphics. The popularity of Open GL has now made GKS obsolete.

## 17.6 OPENGL

Silicon Graphics (SGI) developed the OpenGL application-programming interface (API) for the development of 2D and 3D graphics applications. It is a low-level vendor-neutral software interface. It is often referred to as the assembler language of computer graphics. It provides enormous flexibility and functionality. It is used on a variety of platforms.

OpenGL is a low-level graphics library specification. OpenGL makes available to the programmer a small set of geometric primitives - points, lines, polygons, images, and bitmaps. OpenGL provides a set of commands that allow the specification of geometric objects in two or three dimensions, using the provided primitives, together with commands that control how these objects are rendered into the frame buffer.

The OpenGL API was designed for use with the C and C++ programming languages but there are also bindings for a number of other programming languages such as Java, Ada, and FORTRAN. OpenGL provides primitives for modelling in 3D. Its capabilities

include viewing and modelling transformation, viewport transformation, projections (orthographic and perspective), animation, lighting etc.

## 17.7 PARASOLID

Most high-end CAD/CAM systems have their proprietary geometric modeler embedded within the modeling application. Parasolid is a portable “kernel” that can be used in multiple systems - both high-end and mid-range. In the early 1990s a number of software developers decided to adopt Parasolid. By adopting Parasolid, start-up software companies have eliminated a major barrier to application development - a high initial investment. This enabled them to effectively market softwares with strong solid modeling functionality at lower-cost.

Today Parasolid is used as component software in many of the world’s leading CAD/CAM systems. Unigraphics and Solid Edge, Parametric Technology, Solid Works Corporation ANSYS, Mechanical Dynamics, McNeal-Schwendler and Bentley systems are today using Parasolid. Companies such as Boeing, Israel Aircraft Industries and Mitsubishi Motors use Parasolid for internal development.

### 17.7.1 MODELING FUNCTIONALITIES OF PARASOLID

Parasolid’s modeling abilities include:

- (i) **Complex Blending:** Parasolid provides excellent functionality of blending edges and faces. The functions include, rolling ball, variable, face-face, cliff-edge, overlapping, overflowing, continuous, tangent hold line, disc and conic section and conic hold line.
- (ii) **Hollowing, Shelling, Offsetting and Thickening Surfaces:** These are methods for creating thin-walled parts, which are very common in many industries. To the CAD/CAM user, these are conceptually simple, but the topological changes required are a rigorous test of modeler reliability.
- (iii) **Tapering and Draft Angles:** These operations are used primarily for mold and die design. Parasolid can apply taper to complex designs following complex parting lines. Non-uniform scaling is another useful feature.
- (iv) **Complex Modeling Using B-Surfaces:** These are methods for creating thin-walled parts, which are very common in many industries. To the CAD/CAM user these are conceptually simple, but the topological changes required are a rigorous test of modeler reliability.
- (v) **Tolerant Modeling and B-rep Import Tools:** Parasolid’s Tolerant Modeling technology helps to import geometry, particularly trimmed surfaces from other modelers even when they are less accurate. Parasolid can apply different tolerances to each entity to accommodate anomalies in imported geometry. When improved trimmed surfaces do not fit exactly to Parasolid’s high accuracy,

the surfaces can be sewn together by asking Parasolid to calculate appropriate tolerances to optimize performance and reliability.

In a nutshell, Parasolid incorporates object-oriented routines needed to create real life, complex models great accuracy, reliability and speed. Some of the functionalities in Parasolid are:

- Creation of solid primitives: blocks, cones, cylinders, tori, and spheres
- Creation of solids using swept and spun profiles
- Creation of solids by sewing and knitting of trimmed surfaces
- NURBS curves and surfaces as well as analytical curves and surfaces
- Non-manifold, cellular and mixed dimension topologies
- feature modeling applications through Booleans and instancing
- Complex blending and chamfering
- Non-uniform scaling
- Tolerant Modeling enables reliable modeling with imported data
- Geometry and topology inquiries
- Interference detection and clearance calculations
- Calculation of mass and inertia properties
- Foreign geometry interface to allow import from proprietary geometric systems
- Full range of geometric output formats including trimmed surface
- Graphical data output for wire-frame, silhouettes, hidden line and faceting

### 17.7.2 APPLICATIONS

- (i) **Computer Aided Design:** CAD systems create mathematical models based on user input. Individual models can then be combined as components of an assembly to create a product. Parasolid adds value by being able to model real life objects more accurately and more reliably.
- (ii) **Computer Aided Engineering:** CAE systems analyze designs created by CAD systems by calculating stress, applying the principles of thermodynamics, vibration, mechanisms, acoustics, aerodynamics and electromagnetism. Analyzing, making design changes and re-analyzing optimize a design.
- (iii) **Computer Aided Manufacturing:** CAM systems generate programs for CNC machine tools to manufacture a component. CAM covers every type of machining process from simple turning on a lathe to 5 axes milling of complex surfaces. Parasolid adds value by permitting the import of models from many Parasolid-based CAD systems and the interrogation of the geometry and topology.
- (iv) **Translators:** Parasolid is capable of accepting data from other modeler formats. Its unique Tolerant Modeling functionality can accommodate and compensate for less accurate data.

## 17.8 ACIS

ACIS is another object oriented three-dimensional geometric modeling engine. It is designed for use as the geometry foundation in a 3D modeling application.

ACIS is written in C++ and consists of a set of C++ classes and functions. A developer uses these classes and functions to create an end user 3D application. ACIS complements existing applications by offering a unified environment for the modeling of curves, surfaces and solids. ACIS provides a foundation of common modeling functionality and flexibility to be adapted and extended for particular application requirements.

ACIS integrates wire frame, surface and solid modeling by allowing these alternative representations to coexist naturally in a unified data structure, which is implemented in a hierarchy of C++ classes. ACIS bodies can have any of these forms or combinations of them. Linear and quadratic geometry is represented analytically and non-uniform rational B-Splines represent free-form geometry. ACIS is a boundary-representation (B-rep) modeler, which means that it defines the boundary between solid material and empty space. This boundary is made from a closed set of surfaces.

### 17.8.1 ACIS ARCHITECTURE

The ACIS has been designed using software component technology. A 'software component' is a functionally specialized unit of software - a collection of software items (functions, classes, etc.) grouped together to serve some distinct purpose. It serves as a constituent part of a whole software system or product. A 'product' is one or more software components that are assembled together and sold as a package. Components can be arranged in different combinations to form different products.

#### ***Some of the ACIS components are:***

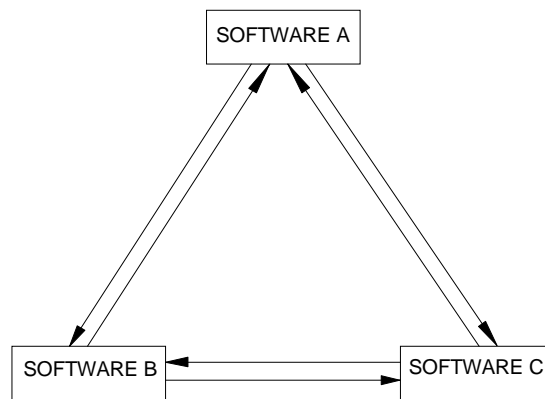
- |                     |   |  |
|---------------------|---|--|
| Advanced Blending   | - | Optional husk for blending beyond standard ACIS blending   |
| AG spline           | - | Spline library and interface   |
| ACISMFC             | - | Support for MFC based applications   |
| Boolean             | - | Unite, intersect and subtract operations   |
| Clearance           | - | Determine minimum distance between bodies or faces   |
| Constructors        | - | Basic topology construction; wire frame construction and editing; analysis (area, length, mass properties) |
| Cellular Topology   | - | Divide lumps into sets of cells  |
| Euler Operations    | - | Expand, separate and combine lumps   |
| Faceter             | - | Generate faceted (polygonal) representation  |
| Generic Attributes  | - | Attributes that allow applications to exchange data  |
| Graphic Interaction | - | Commonly needed graphic display functionality  |



Kernel	-	Basic entity and attribute support, topology and geometry entity classes; construction geometry classes
Local OPS	-	Optional husk for locally manipulating models
Meshing	-	Optional husk for representing a surface as a network of polygonal elements
Sweeping	-	Sweep a profile along a path

### 17.9 EXCHANGE OF CAD DATA BETWEEN SOFTWARE PACKAGES

Necessity to translate drawings created in one drafting package to another often arises. For example you may have a CAD model created in PRO/E package and you may wish that this might be transferred to I-DEAS or Unigraphics. It may also be necessary to transfer geometric data from one software to another. This situation arises when you would want to carry out modeling in one software, say PRO/E and analysis in another software, say ANSYS. One method to meet this need is to write direct translators from one software to another. This means that each system developer will have to produce its own translators. This will necessitate a large number of translators. If we have three software packages we may require six translators among them. This is shown in Fig. 17.3.

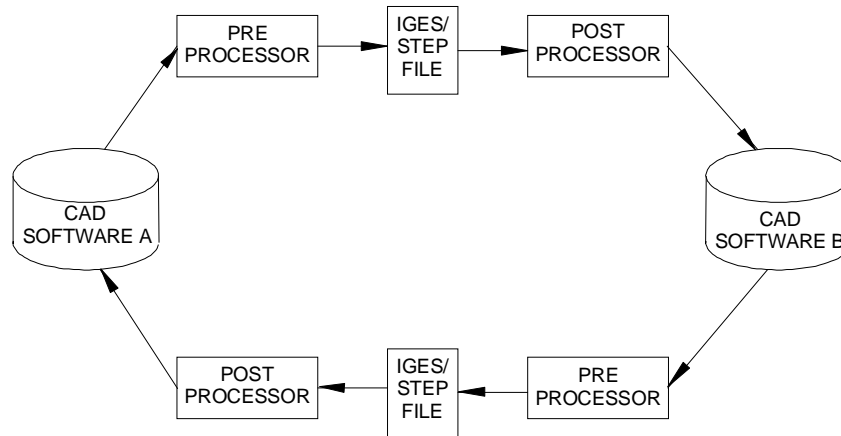


**Fig. 17.3 Direct Data Translation**

A solution to this problem of direct translators is to use neutral files. These neutral files will have standard formats and software packages can have pre-processors to convert drawing data to neutral file and postprocessors to convert neutral file data to drawing file. Figure 17.4 illustrates how the CAD data transfer is accomplished using neutral file. Three types of neutral files are discussed in this chapter. They are:

- i. Drawing exchange files (DXF)
- ii. IGES files
- iii. STEP files

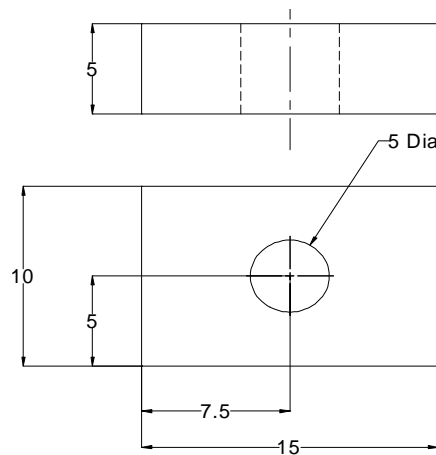
Brief descriptions of these are given in the following sections.



**Fig. 17.4 CAD Data Exchange Using Neutral Files**

**17.10 DXF FILES**

DXF file (Drawing Exchange File) is a popular data exchange format adopted by many CAD system vendors. DXF format is easy to interpret though it is a lengthy file. The data pertaining to the drawing entities are included in the entities section. Fig. 17.5 shows a plate with a hole. The contents of the entity section of the DXF file of this component are given in Table 17.1.



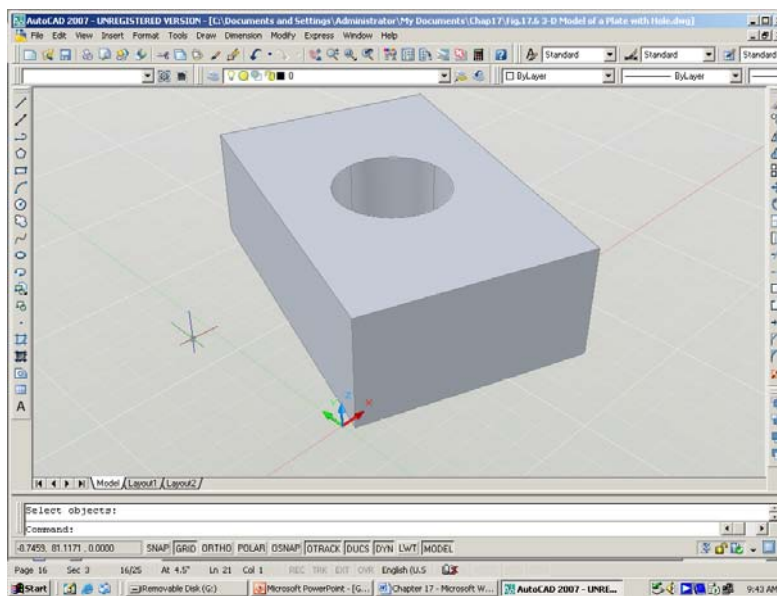
**Fig. 17.5 A Plate with a Hole**

Table 17.1 A Portion of DXF File

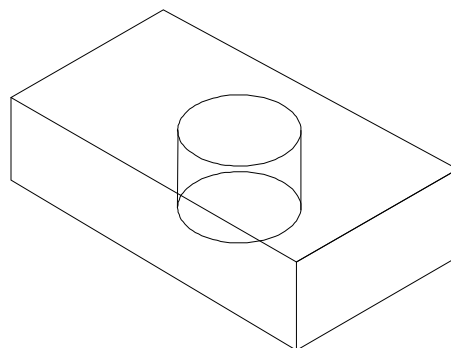
	20	137.6432581938739
	127.6432581938739	30
	30	0.0
	0.0	11
0	11	137.1906423418079
SECTION	152.1906423418079	21
2	21	127.6432581938739
ENTITIES	137.6432581938739	31
0	31	0.0
LINE	0.0	0
5	0	CIRCLE
2B	LINE	5
330	5	31
1F	2D	330
100	330	1F
AcDbEntity	1F	100
8	100	AcDbEntity
0	AcDbEntity	8
100	8	0
AcDbLine	0	100
10	100	AcDbCircle
137.1906423418079	AcDbLine	10
20	10	144.6906423418079
127.6432581938739	152.1906423418079	20
30	20	132.6432581938739
0.0	137.6432581938739	30
11	30	0.0
152.1906423418079	0.0	40
21	11	2.5
127.6432581938739	137.1906423418079	0
31	21	ENDSEC
0.0	137.6432581938739	
0	31	
LINE	0.0	
5	0	
2C	LINE	
330	5	
1F	2E	
100	330	
AcDbEntity	1F	
8	100	
0	AcDbEntity	
100	8	
AcDbLine		
10	0	
152.1906423418079	100	
	AcDbLine	
	10	
	137.1906423418079	
	20	

### 17.11 INITIAL GRAPHICS EXCHANGE SPECIFICATION (IGES) GRAPHICS STANDARD

The IGES committee was established in the year 1979. The CAD/CAM Integrated Information Network (CIIN) of Boeing served as the preliminary basis of IGES. IGES version 1.0 was released in 1980. IGES continues to undergo revisions. IGES is a popular data exchange standard today. Figure 17.6 shows a CAD model of a plate with a centre hole. The wire frame model of the component is shown in Fig. 17.7. There are eight vertices (marked as PNT 0 - PNT 8), 12 edges and two circles that form the entities of the model. Table 17.2 shows the IGES output of the wire frame model.



**Fig. 17.6 3-D Model of a Plate**



**Fig. 17.7 Wire-frame Model of the Component**

**Table 17.2 IGES-Wire frame edges**

PTC IGES file: Wireframe_Edges.igs							S	1
1H,,1H;4HSTEP,6Hi1.igs,							G	1
49HPro/ENGINEER by Parametric Technology Corporation,7H1999390,32,38,7,							G	2
38,15,4HSTEP,1.,2,2HMM,32768,0.5,13H000104.164438,0.00187075,18.708,							G	3
5Hstaff,7HUnknown,10,0,13H000104.164438;							G	4
110	1	1	1	0	0	0	00000000D	1
110	0	0	1	0	LINE	1D		2
110	2	1	1	0	0	0	00000000D	3
110	0	0	1	0	LINE	2D		4
110	3	1	1	0	0	0	00000000D	5
110	0	0	1	0	LINE	3D		6
110	4	1	1	0	0	0	00000000D	7
110	0	0	1	0	LINE	4D		8
124	5	1	1	0	0	0	00100000D	9
124	0	0	1	0	XFORM	1D		10
100	6	1	1	0	0	9	00000000D	11
100	0	0	1	0	ARC	1D		12
110	7	1	1	0	0	0	00000000D	13
110	0	0	1	0	LINE	5D		14
110	8	1	1	0	0	0	00000000D	15
110	0	0	1	0	LINE	6D		16
110	9	1	1	0	0	0	00000000D	17
110	0	0	1	0	LINE	7D		18
110	10	1	1	0	0	0	00000000D	19
110	0	0	1	0	LINE	8D		20
110	11	1	1	0	0	0	00000000D	21
110	0	0	1	0	LINE	9D		22
110	12	1	1	0	0	0	00000000D	23
110	0	0	1	0	LINE	10D		24
110	13	1	1	0	0	0	00000000D	25

110	0	0	1	0	LINE	11D		26
110	14	1	1	0	0	0	00000000D	27
110	0	0	1	0	LINE	12D		28
124	15	1	1	0	0	0	00100000D	29
124	0	0	1	0	XFORM	2D		30
100	16	1	1	0	0	29	00000000D	31
100	0	0	1	0	ARC	2D		32
110	17	1	1	0	0	0	00000000D	33
110	0	0	1	0	LINE	13D		34
110	18	1	1	0	0	0	00000000D	35
110	0	0	1	0	LINE	14D		36
							1P	1
110,0D0,0D0,0D0,0D0,-1D1,0D0;							3P	2
110,0D0,-1D1,0D0,1.5D1,-1D1,0D0;							5P	3
110,1.5D1,-1D1,0D0,1.5D1,0D0,0D0;							7P	4
110,1.5D1,0D0,0D0,0D0,0D0,0D0;							9P	5
124,-1D0,0D0,0D0,7.5D0,0D0,1D0,0D0,-5D0,0D0,0D0,-1D0,0D0;							11P	6
100,0D0,0D0,0D0,2.5D0,0D0,2.5D0,0D0;							13P	7
110,0D0,0D0,0D0,0D0,0D0,5D0;							15P	8
110,1.5D1,0D0,0D0,1.5D1,0D0,5D0;							17P	9
110,1.5D1,-1D1,0D0,1.5D1,-1D1,5D0;							19P	10
110,0D0,-1D1,0D0,0D0,-1D1,5D0;							21P	11
110,0D0,0D0,5D0,0D0,-1D1,5D0;							23P	12
110,1.5D1,0D0,5D0,0D0,0D0,5D0;							25P	13
110,1.5D1,-1D1,5D0,1.5D1,0D0,5D0;							27P	14
110,0D0,-1D1,5D0,1.5D1,-1D1,5D0;							29P	15
124,-1D0,0D0,0D0,7.5D0,0D0,1D0,0D0,-5D0,0D0,0D0,-1D0,5D0;							31P	16
100,0D0,0D0,0D0,2.5D0,0D0,2.5D0,0D0;							33P	17
110,5D0,-5D0,5D0,5D0,-5D0,0D0;							35P	18
110,1D1,-5D0,5D0,1D1,-5D0,0D0;							T	1
S	1G	4D	36P	18				

IGES files can also be generated for:

- i. Surfaces
- ii. Datum curves and points

### **17.12 PRODUCT DATA EXCHANGE SPECIFICATION (PDES)**

A likely alternative to IGES is the product data exchange specification (PDES) developed by IGES organisation. PDES is aimed at defining a more conceptual model. Parts will be based on solids and defined in terms of features such as holes, flanges, or ribs. Instead of dimensions PDES will define a tolerance envelope for the parts to be manufactured. PDES will also contain non-geometric information such as materials used, manufacturing process and suppliers. PDES will be a complete computer model of the part.

### **17.13 OTHER DATA EXCHANGE FORMATS**

There are several existing alternative data exchange formats. These include the Standard Product Data Exchange Format (SDF) of Vought Corporation (available for CADAM, CADD5-5, PATRAN, and PRIME etc.) Standard Interchange Format (SIF) of Intergraph Corporation (available for Applicon, Autotrol, and Calma etc.), ICAM Product Data Definition Interface (PDDI), and VDA sculptured surface Interface (VDAFS), Electronic Design Interchange Format (EDIF), Transfer and Archiving of Product Definition Data (TAP) etc. Another alternative to IGES is the neutral format outlined in ANSI Y14.26M standard. It must be noted here that some of the features of many of these alternatives are superior to that of IGES.

### **17.14 PRODUCT DATA TECHNOLOGY SUPPORT FOR COMPUTER AIDED CONCURRENT ENGINEERING**

Seamless exchange of product data is critical to CAD/CAM/CAE systems. The Standard for the Exchange of Product Data (STEP) is the enabler for such seamless data exchange. It provides a worldwide standard for storing, sharing and exchanging product information among different CAD systems. Although STEP itself is the basis for Product Data Management System (PDM). It covers border functionalities. It includes methods of representing all critical product specifications such as shape information, materials, tolerances, finishes and product structure.

Whereas the Initial Graphics Exchange Specification (IGES) standard has widespread use, it has its shortcomings. It does not convey the extensive product information needed in the design and manufacturing cycle. Often IGES translators are required to move design data from one CAD system to another. STEP is often viewed as a replacement for IGES, though IGES is still expected to be in active use for some more time in the future. Although

the current focus of STEP is on mechanical parts, STEP is a data exchange standard that would apply to a wide range of product areas, including electronics, architectural, engineering and construction, apparel and shipbuilding.

#### 17.14.1 STEP ARCHITECTURE

STEP architecture has four main components:

- EXPRESS modeling language
- Data schemes including attributes such as geometry, topology, features and tolerance.
- Application interface called Standard Data Access Interface (SDAI), which is a standard interface to enable applications to access and manipulate STEP data
- STEP database, which has the following forms:
  - ASCII format file for data exchange
  - Working from file, usually in binary format, that can be shared by multiple systems
  - Shared database, involving object oriented database management system or relational database system
  - Knowledge base, with a database management system as a base coupled to an expert shell

#### 17.14.2 STEP ENABLER FOR CONCURRENT ENGINEERING

STEP was released in early 1993 as a Draft International Standard (DIS). The initial release of STEP has four basic parts. These include:

- EXPRESS modeling language
- Two application protocols
- Drafting and Configuration Control Design for three-dimensional product data.
- Six application resources.

Subsequent releases of STEP provided added functionality in terms of the kinds of product supported and the extent of the product life cycle. While STEP is advancing towards maturity, it had been investigated for the feasibility of incorporation into framework system. Both STEP and Concurrent Engineering share the common goal of influencing the product cycle from design, assembly, etc. to the disposal stages which have been realized in the CONSENS system under ESPRIT EP6896. The object-oriented database for CONSENS has a schema with STEP definitions alongside company specific definitions. A module called Product Information Archive (PIA) provides functionality for STEP data access via SDAI. It is generic to be adopted for different domains.

For example it is used for product information by the Aircraft Company, Deutshces Aerospace and electronics manufacturing company, AEG.



STEP data export in a CAD modeling package has the following options:

- (i) wire frame edges
- (ii) surfaces
- (iii) solids
- (iv) shells
- (v) Datum curves and points

A typical STEP output for the wire frame model shown in Fig. 17.7 is given in Table 17.3.

**Table 17.3 STEP Output**

```
ISO-10303-21;
HEADER;
FILE_DESCRIPTION(('','1');
FILE_NAME('STEP','2000-01-04T','staff'),(''),
'PRO/ENGINEER BY PARAMETRIC TECHNOLOGY CORPORATION, 1999390',
'PRO/ENGINEER BY PARAMETRIC TECHNOLOGY CORPORATION, 1999390',);
FILE_SCHEMA(('CONFIG_CONTROL_DESIGN'));
ENDSEC;
DATA;
#1=DIRECTION(",(0.E0,-1.E0,0.E0));
#2=VECTOR(",#1,1.E1);
#3=CARTESIAN_POINT(",(0.E0,0.E0,0.E0));
#4=LINE(",#3,#2);
#6=GEOMETRIC_CURVE_SET(",(#5,#11,#16,#21,#27,#32,#37,#42,#47,#52,#57,
#62,#67,#73,#78,#83));
#7=DIRECTION(",(1.E0,0.E0,0.E0));
#8=VECTOR(",#7,1.5E1);
#9=CARTESIAN_POINT(",(0.E0,-1.E1,0.E0));
#10=LINE(",#9,#8);
#12=DIRECTION(",(0.E0,1.E0,0.E0));
#13=VECTOR(",#12,1.E1);
#14=CARTESIAN_POINT(",(1.5E1,-1.E1,0.E0));#15=LINE(",#14,#13);
#17=DIRECTION(",-1.E0,0.E0,0.E0));
#18=VECTOR(",#17,1.5E1);
#19=CARTESIAN_POINT(",(1.5E1,0.E0,0.E0));
#20=LINE(",#19,#18);
#22=CARTESIAN_POINT(",(7.5E0,-5.E0,0.E0));
```

*Contd...*

```
#23=DIRECTION(",(0.E0,0.E0,-1.E0));
#24=DIRECTION(",-1.E0,0.E0,0.E0));
#25=AXIS2_PLACEMENT_3D("#22,#23,#24);
#28=DIRECTION(",(0.E0,0.E0,1.E0));
#29=VECTOR("#28,5.E0);
#30=CARTESIAN_POINT(",(0.E0,0.E0,0.E0));
#31=LINE("#30,#29);
#33=DIRECTION(",(0.E0,0.E0,1.E0));
#34=VECTOR("#33,5.E0);
#35=CARTESIAN_POINT(",(1.5E1,0.E0,0.E0));
#36=LINE("#35,#34);
#38=DIRECTION(",(0.E0,0.E0,1.E0));
#39=VECTOR("#38,5.E0);
#40=CARTESIAN_POINT(",(1.5E1,-1.E1,0.E0));
#41=LINE("#40,#39);
#43=DIRECTION(",(0.E0,0.E0,1.E0));
#44=VECTOR("#43,5.E0);
#45=CARTESIAN_POINT(",(0.E0,-1.E1,0.E0));
#46=LINE("#45,#44);
#48=DIRECTION(",(0.E0,-1.E0,0.E0));
#49=VECTOR("#48,1.E1);
#50=CARTESIAN_POINT(",(0.E0,0.E0,5.E0));
#51=LINE("#50,#49);
#53=DIRECTION(",-1.E0,0.E0,0.E0));
#54=VECTOR("#53,1.5E1);
#55=CARTESIAN_POINT(",(1.5E1,0.E0,5.E0));
#56=LINE("#55,#54);
#58=DIRECTION(",(0.E0,1.E0,0.E0));
#59=VECTOR("#58,1.E1);
#60=CARTESIAN_POINT(",(1.5E1,-1.E1,5.E0));
#61=LINE("#60,#59);
#63=DIRECTION(",(1.E0,0.E0,0.E0));
#64=VECTOR("#63,1.5E1);
#65=CARTESIAN_POINT(",(0.E0,-1.E1,5.E0));
#66=LINE("#65,#64);
#68=CARTESIAN_POINT(",(7.5E0,-5.E0,5.E0));#69=DIRECTION(",(0.E0,0.E0,-1.E0));
#70=DIRECTION(",-1.E0,0.E0,0.E0));
#71=AXIS2_PLACEMENT_3D("#68,#69,#70);
#74=DIRECTION(",(0.E0,0.E0,-1.E0));
```

Contd....

```

#75=VECTOR(",#74,5.E0);
#76=CARTESIAN_POINT(",(5.E0,-5.E0,5.E0));
#77=LINE(",#76,#75);
#79=DIRECTION(",(0.E0,0.E0,-1.E0));
#80=VECTOR(",#79,5.E0);
#81=CARTESIAN_POINT(",(1.E1,-5.E0,5.E0));
#82=LINE(",#81,#80);
#84=(LENGTH_UNIT()NAMED_UNIT(*)SI_UNIT(.MILLI.,METRE.));
#85=DIMENSIONAL_EXPONENTS(0.E0,0.E0,0.E0,0.E0,0.E0,0.E0);
#86=(NAMED_UNIT(*)PLANE_ANGLE_UNIT()SI_UNIT($,RADIAN.));
#87=PLANE_ANGLE_MEASURE_WITH_UNIT(PLANE_ANGLE_MEASURE(1.745329251994E-2),#86);
#88=(CONVERSION_BASED_UNIT('DEGREE',#87)NAMED_UNIT(#85)
PLANE_ANGLE_UNIT());
#89=(NAMED_UNIT(*)SI_UNIT($,.STERADIAN.)SOLID_ANGLE_UNIT());
#90=UNCERTAINTY_MEASURE_WITH_UNIT(LENGTH_MEASURE(1.870753860239E-3),#84,
'closure',
'Maximum model space distance between geometric entities at asserted connectivity');
#91=(GEOMETRIC_REPRESENTATION_CONTEXT(3)GLOBAL_UNCERTAINTY_ASSIGNED_CONTEXT(
(#90))GLOBAL_UNIT_ASSIGNED_CONTEXT((#84,#88,#89))
REPRESENTATION_CONTEXT('ID1','3'));
#93=APPLICATION_CONTEXT(
'CONFIGURATION CONTROLLED 3D DESIGNS OF MECHANICAL PARTS AND ASSEMBLIES');
#94=APPLICATION_PROTOCOL_DEFINITION('international standard',
'config_control_design',1994,#93);
#95=DESIGN_CONTEXT(",#93,'design');
#96=MECHANICAL_CONTEXT(",#93,'mechanical');
#97=PRODUCT('STEP','STEP','NOT SPECIFIED',(#96));
#98=PRODUCT_DEFINITION_FORMATION_WITH_SPECIFIED_SOURCE(3,'LAST_VERSION',#97,MADE.);
#102=PRODUCT_CATEGORY('part','');
#103=PRODUCT_RELATED_PRODUCT_CATEGORY('detail','',(#97));
#104=PRODUCT_CATEGORY_RELATIONSHIP(",",#102,#103);
#105=SECURITY_CLASSIFICATION_LEVEL('unclassified');
#106=SECURITY_CLASSIFICATION(",",#105);
#107=CC_DESIGN_SECURITY_CLASSIFICATION(#106,(#98));
#108=APPROVAL_STATUS('approved');
#109=APPROVAL(#108,"");
#110=CC_DESIGN_APPROVAL(#109,(#106,#98,#99));
#111=CALENDAR_DATE(100,4,1);
#112=COORDINATED_UNIVERSAL_TIME_OFFSET(5,30,.AHEAD.);

```

Contd....

```

#113=LOCAL_TIME(17,50,1.E1,#112);
#114=DATE_AND_TIME(#111,#113);
#115=APPROVAL_DATE_TIME(#114,#109);
#116=DATE_TIME_ROLE('creation_date');
#117=CC_DESIGN_DATE_AND_TIME_ASSIGNMENT(#114,#116,(#99));
#118=DATE_TIME_ROLE('classification_date');
#119=CC_DESIGN_DATE_AND_TIME_ASSIGNMENT(#114,#118,(#106));
#120=PERSON('UNSPECIFIED','UNSPECIFIED',$,$,$);
#121=ORGANIZATION('UNSPECIFIED','UNSPECIFIED','UNSPECIFIED');
#122=PERSON_AND_ORGANIZATION(#120,#121);
#123=APPROVAL_ROLE('approver');
#124=APPROVAL_PERSON_ORGANIZATION(#122,#109,#123);
#125=PERSON_AND_ORGANIZATION_ROLE('creator');
#126=CC_DESIGN_PERSON_AND_ORGANIZATION_ASSIGNMENT(#122,#125,(#98,#99));
#127=PERSON_AND_ORGANIZATION_ROLE('design_supplier');
#128=CC_DESIGN_PERSON_AND_ORGANIZATION_ASSIGNMENT(#122,#127,(#98));
#129=PERSON_AND_ORGANIZATION_ROLE('classification_officer');
#130=CC_DESIGN_PERSON_AND_ORGANIZATION_ASSIGNMENT(#122,#129,(#106));
#131=PERSON_AND_ORGANIZATION_ROLE('design_owner');
#132=CC_DESIGN_PERSON_AND_ORGANIZATION_ASSIGNMENT(#122,#131,(#97));
#5=TRIMMED_CURVE(" ,#4,(PARAMETER_VALUE(0.E0)),(PARAMETER_VALUE(1.E0)),T.,
.UNSPECIFIED.);
#11=TRIMMED_CURVE(" ,#10,(PARAMETER_VALUE(0.E0)),(PARAMETER_VALUE(1.E0)),T.,
.UNSPECIFIED.);
#16=TRIMMED_CURVE(" ,#15,(PARAMETER_VALUE(0.E0)),(PARAMETER_VALUE(1.E0)),T.,
.UNSPECIFIED.);
#21=TRIMMED_CURVE(" ,#20,(PARAMETER_VALUE(0.E0)),(PARAMETER_VALUE(1.E0)),T.,
.UNSPECIFIED.);
#26=CIRCLE(" ,#25,2.5E0);
#27=TRIMMED_CURVE(" ,#26,(PARAMETER_VALUE(0.E0)),(PARAMETER_VALUE(3.6E2)),
T.,UNSPECIFIED.);
#32=TRIMMED_CURVE(" ,#31,(PARAMETER_VALUE(0.E0)),(PARAMETER_VALUE
(1.E0)),.T.,
.UNSPECIFIED.);#37=TRIMMED_CURVE(" ,#36,(PARAMETER_VALUE(0.E0)),(PARAMETER_VALUE
(1.E0)),.T., .UNSPECIFIED.);
#42=TRIMMED_CURVE(" ,#41,(PARAMETER_VALUE(0.E0)),(PARAMETER_VALUE(1.E0)),.T.
.UNSPECIFIED.);
#47=TRIMMED_CURVE(" ,#46,(PARAMETER_VALUE(0.E0)),(PARAMETER_VALUE(1.E0)),.T.,
.UNSPECIFIED.);

```

Contd....

```
#52=TRIMMED_CURVE(" #51,(PARAMETER_VALUE(0.E0)),(PARAMETER_VALUE(1.E0)),.T.,
.UNSPECIFIED.);
#57=TRIMMED_CURVE(" #56,(PARAMETER_VALUE(0.E0)),(PARAMETER_VALUE(1.E0)),.T.,
.UNSPECIFIED.);
#62=TRIMMED_CURVE(" #61,(PARAMETER_VALUE(0.E0)),(PARAMETER_VALUE(1.E0)),.T.,
.UNSPECIFIED.);
#67=TRIMMED_CURVE(" #66,(PARAMETER_VALUE(0.E0)),(PARAMETER_VALUE(1.E0)),.T.,
.UNSPECIFIED.);
#72=CIRCLE(" #71,2.5E0);
#73=TRIMMED_CURVE(" #72,(PARAMETER_VALUE(0.E0)),(PARAMETER_VALUE(3.6E2)),.T.,
.UNSPECIFIED.);
#78=TRIMMED_CURVE(" #77,(PARAMETER_VALUE(0.E0)),(PARAMETER_VALUE(1.E0)),.T.,
.UNSPECIFIED.);
#83=TRIMMED_CURVE(" #82,(PARAMETER_VALUE(0.E0)),(PARAMETER_VALUE(1.E0)),.T.,
.UNSPECIFIED.);
#92=GEOMETRICALLY_BOUNDED_WIREFRAME_SHAPE_REPRESENTATION(" (#6),#91);
#99=PRODUCT_DEFINITION('design',",#98,#95);
#100=PRODUCT_DEFINITION_SHAPE(" ;SHAPE FOR STEP.',#99);
#101=SHAPE_DEFINITION_REPRESENTATION(#100,#92);
ENDSEC;
END-ISO-10303-21;
```

## QUESTIONS

1. Discuss the need for standardisation in Computer Graphics.
2. Compare CORE and GKS graphics standards.
3. What are the salient features of GKS?
4. Describe the structure of an IGES file.
5. Describe briefly the various data exchange systems currently in use.
6. Create a CAD model and obtain the export files in different formats and make a comparative study.

*CIM is a technology evolved over a period of time and deals with several applications to tie together activities like design, planning and manufacturing. There has to be seamless integration of data across these applications. Till recently, this has not been the case. This lack of integration can often be attributed to a lack of understanding of the mappings of data among individual systems. A CIM model is a methodology for expressing these mappings. Several software models have been proposed to implement CIM. Some of the well-known CIM models are reviewed in this Chapter.*

## 18.1 INTRODUCTION

Industrial enterprises throughout the world are undergoing a transformation. Globalization of economy has thrown several challenges to the manufacturing manager. The products are now designed to meet the specific market needs. The concept of make-to-stock is increasingly replaced by make-to-need. Quick response to market needs is another important requirement today. Enterprises are exploring new ways to manufacture products with better and better quality at competitive prices. Manufacturers are recognizing competitive advantages in service differentiation to the customers. Environmental aspects and safety features are factors of major concern of product designers and manufacturing engineers. These are reflected in the current trend to re-examine the business processes and the shift to the optimization of the business processes.

Industrial concepts like agile manufacturing, lean production, teamwork, and collaborative product engineering, maximum use of communication facilities like Internet, etc. are being adopted by the industries for this purpose. Topics like elimination of waste and continuous improvement of products and processes are to-day common in the agenda of manufacturing engineers.

The role of information systems and technology is very critical for implementing these concepts. Therefore the CIM architecture to day attempts to integrate business processes, people, computers, and software through an infrastructure of enabling platforms. Computer Integrated Manufacturing (CIM) is an ideal concept in which computer based manufacturing applications communicate information to coordinate design, planning and

manufacturing processes. Traditional approaches to integration focus on either developing translations between two systems or a single data file that acts as a database for all integrated tools. What is needed, however, is an integration architecture, which supports each application's local data requirements. To understand each system's data requirements, there is a need to model them using a unified information model.

Manufacturing management today has to face several challenges, in order to be competitive in the world market. The manufacturing system has to be highly flexible. At the same time the delivery schedules are to be strictly adhered to. The various problems that manufacturing companies face are listed below:

- (i) Manufacturing of products often requires introduction of changes in specifications as the job progresses.
- (ii) Capacity management is often one of the tough problems. Manufacturing jobs are complex which make scheduling to meet delivery dates a difficult exercise. Sometimes a customer wants rescheduling which makes it necessary to reschedule many other jobs.
- (iii) For efficient manufacturing management it is necessary to track at various order levels, component levels and assembly levels. Tracking is also necessary to monitor material consumption, material flow and cost.
- (iv) It may be necessary to strike a balance between make to order and make to stock depending upon the market conditions.

The approach to CIM model development is quite different from traditional database approach. As in a traditional database environment, a CIM environment involves many tools, which may be modeling the same entity. The data in CIM could be grouped into three: life cycle related, domain related and level of abstraction related. Within these categories, data integration or translation may be well-defined. Life cycle related applications include requirements definition, design process and implementation procedures. The domain related group includes detailed design, production planning and control, manufacturing, inspection, assembly, testing, shipping, marketing, sales and servicing and retirement of the product. The design of the manufacturing facility and the development and implementation of the corporate management structure form an entirely different group.

The need to integrate various shop floor and operation management related activities into a system has led to the development of a number of software models. Some of them may not be in active use today but are historically important in the development of CIM. These models have been developed by either joint international initiative like ESPRIT or computer companies like IBM. Some of the models are briefly described below:

- (i) ESPRIT - CIM OSA Model
- (ii) NIST-AMRF Hierarchical Model
- (iii) Siemens Model of CIM

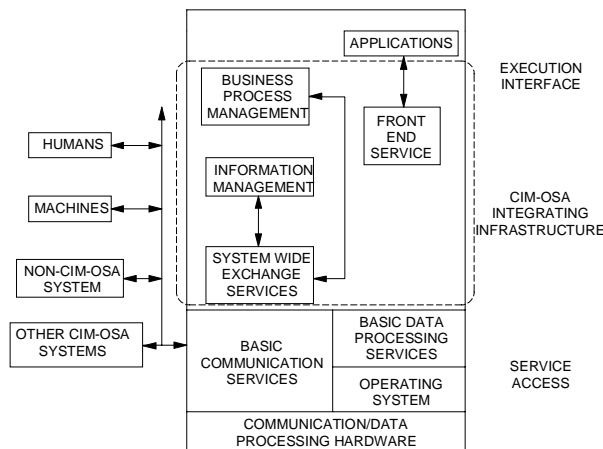
- (iv) CIM Model of Digital Equipment Corporation
- (v) IBM Model of CIM

The following sections describe these approaches in detail.

### 18.2 ESPRIT - CIM OSA MODEL

European Strategic Program for Research and Development in Information Technology (ESPRIT) is an industrially oriented R&D program with the aim of improving the competitiveness of the European Community industries. The ESPRIT strategy has been the creation of an environment in which multi-vendor production systems can be implemented at reasonable cost. (OSA refers to Open System Architecture). CIM- OSA was developed by AMICE (a consortium of 30 major European vendors and users of CIM systems (e.g. IBM, HP, DEC, Siemens, Fiat, and Daimler-Benz) for ESPRIT.

Within the framework of the CIM-OSA concept, it is possible to construct CIM architectures for various manufacturing industries and applications from basic building blocks according to defined guidelines. An integrating infrastructure is provided to organize and schedule the enterprise activities. Fig. 18.1 shows CIM-OSA integrating infrastructure. Since activities, information and control are treated as three different entities, it is possible to make changes in one entity without greatly affecting another one. The dynamic feature of the model enhances the flexibility of an enterprise to quickly adapt to changing material and information flow.



**Fig. 18.1 CIM-OSA Integrating Infrastructure**

CIM-OSA separates functions using two interrelated concepts.

- The CIMOSA Modeling Framework in which specific and generic functions are clearly separated.

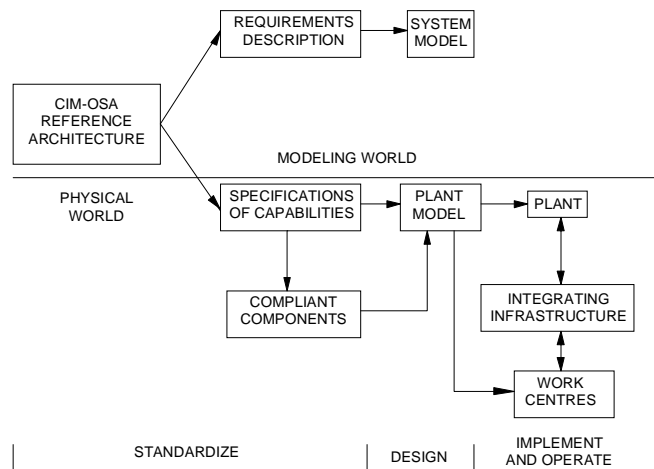


- The CIMOSA Integrating Infrastructure supporting execution of generic functions and linking specific functions. It is effectively the communication system, which interconnects all of the functions in the CIM system.

CIMOSA defines four modeling views of the enterprise functions:

- The Function View describes work flows
- The Information View describes the Inputs and Outputs of Functions
- The Resource View describes the structure of resources (Humans, machines, and control and information systems)
- The Organization View defines authorities and responsibilities

An enterprise consists of engineering and operation functions. The CIM-OSA model provides a mechanism for preparing and structuring the planning and control activities of these functions and for changing structured information between them. With the help of a computer, a planner is able to consult the CIM-OSA reference architecture to construct an operating environment for his application (Fig. 18.2).



**Fig. 18.2 Operating Environment to Apply CIM-OSA Model**

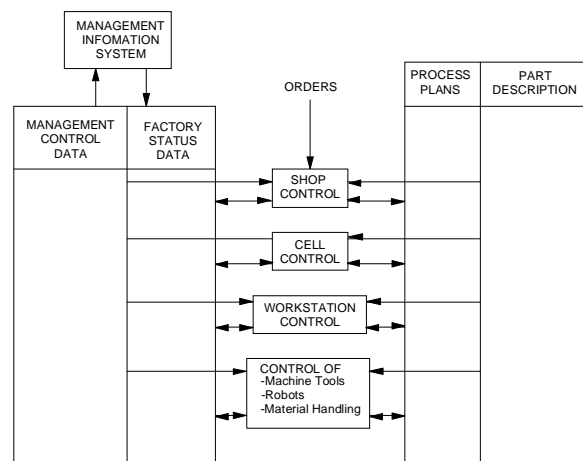
The manufacturing operation can be described with the help of requirements description language to draft the enterprise model and the specification of the basic capabilities to define the compliant components. With the available CIM-OSA reference architecture, user describes the basic capabilities, which are needed for building the system. The user also specifies a set of standard services to execute the task of the enterprise using modules of the physical system. With this information, the system selects the necessary modules from the library of compliant components, which forms the basic building blocks for configuring the physical manufacturing system.

The CIM-OSA model has a hierarchical structure to describe an enterprise, and the intermediate and implementation levels to define sub-functions.

### 18.3 THE NIST - AMRF HIERARCHICAL MODEL

At National Institute of Standards and Technology (NIST, Germany), an Advanced Manufacturing Research Facility (AMRF) was built and operated to work out the hardware and software standards for computer controlled manufacturing system. A hierarchical computer and sensor system is assumed to plan and control the manufacturing operations. Like the other models, the NIST model greatly facilitates the configuration of a control system for manufacturing. The model is of particular value to small and medium sized batch operations.

The model consists of three columns, a management information system, a control system and a design and planning system (Fig. 18.3). The design and process planning system prepares the manufacturing documents. Information about an order is entered and global goals and strategies are decided. The order initiates the manufacturing, design and process planning activities. At each lower level the processing of the order is refined successively until a set of primitive control instructions is generated to directly operate the manufacturing equipment.



**Fig. 18.3 NIST-AMRF Model**

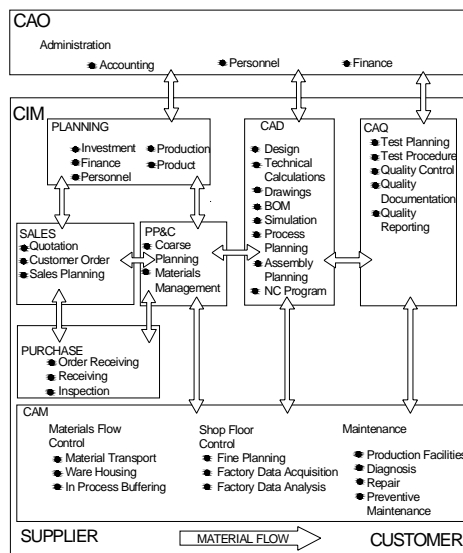
Each level of control obtains only that information which is pertinent for the fulfillment of its assignment. Every information needed for making the product like material selection, determination of machining operations and sequences (process plan), calculations of machining parameters, part scheduling, part routing etc., is generated. The management information system knows the order priorities, status of manufacturing equipment, material availability, on-line processing status, quality of products etc. The sensors in the shop floor level collect status information about the manufacturing process and send this information upwards to provide feedback to all levels. Components can be added and deleted with a minimum of effort and disturbance to the activities on the shop floor. The central database contains a complete state description of the factory at any given time, and thus the system can respond immediately to any production change or disturbance.

## 18.4 THE SIEMENS MODEL OF CIM

The Siemens model of CIM comprises the main functions of planning, sales, purchasing, production planning and control, computer aided design, computer aided quality control and computer aided manufacture interconnected by intensive information flow. The requirements for a factory wide data processing system as envisaged in this model are:

- What kind of data is generated?
- What kind of data is needed and where are they used?
- Who administers and maintains the data?
- Who is responsible for what data?
- What data are kept in common database?
- Where must data be obtained from and where must data be sent?

In order to be able to process the data in a comprehensive manufacturing system, a hierarchical model of an enterprise is used. Each hierarchical level has its own data processing requirements and there exists a steady flow of instructions from the upper levels to the lower ones. In order to control and synchronize parallel activities on each level, an intensive horizontal data flow takes place. Siemens model also incorporates a Computer Aided Organization (CAO), which comprises accounting, personnel and finance. The Siemens CIM concept is shown in Fig. 18.4 with structured details of every major module. For each module, its sub modules are defined and their interconnections are explained. A description is given on the required interfaces for the data exchange and the contents of the data, giving special considerations to batch and mass production. Various layouts of production systems and assembly stations are also considered.



**Fig. 18.4. Siemens Concept of CIM**

## 18.5 THE CIM MODEL OF DIGITAL EQUIPMENT CORPORATION

For the Digital Equipment Corporation (DEC) CIM is the improvement of a manufacturing processes with the aid of the computer and the integration of the information processing of all enterprise activities. The entire control system is divided into functional modules, which reflect the business and the data. CIM design starts with the analysis of all manufacturing activities and identifies their functions and data flow. This assists the layout of physical system leading to a functional model and a physical model of a manufacturing system and its subsystems.

The information support technologies described are:

- The interface service to data sinks and data sources
- The data processing service
- The data storage and retrieval service
- The networking service for distributed systems.

Fig. 18.5 shows a CIM model of DEC, which actually resembles the Siemens model and has many identical features. A well-structured information technology model supports the individual activities of this model. The system integration is a strong effort within the framework of this CIM model. The scope of integration comprises the business functions, data structure, hardware-software architecture and information systems. These are briefly explained below:

**Business function integration:** For this activity, the business functions are defined and all computer programs are assembled to support them. Combining the internal process functions and defining the data exchange mainly achieve the integration.

**Data structure integration:** Successful system integration is achieved by organizing all data in a defined physical database in which the logical associations are well structured. An attempt is made to set up distinct data structures for the various applications and to define algorithms, which establish links between the data structures.

**Infrastructure integration:** The system architecture is conceived as a distributed environment using heterogeneous hardware and software components. Features included are transportable software and application packages, device independent storage and retrieval, unhindered data exchange, unique query languages, unified operating systems, common networks and protocols, high modularity and possibilities of adapting quickly to technology changes.

**Information system integration:** System integration is considered to be an ongoing incremental process, which adapts to the ever-present changes of business functions, data structures and infrastructures.

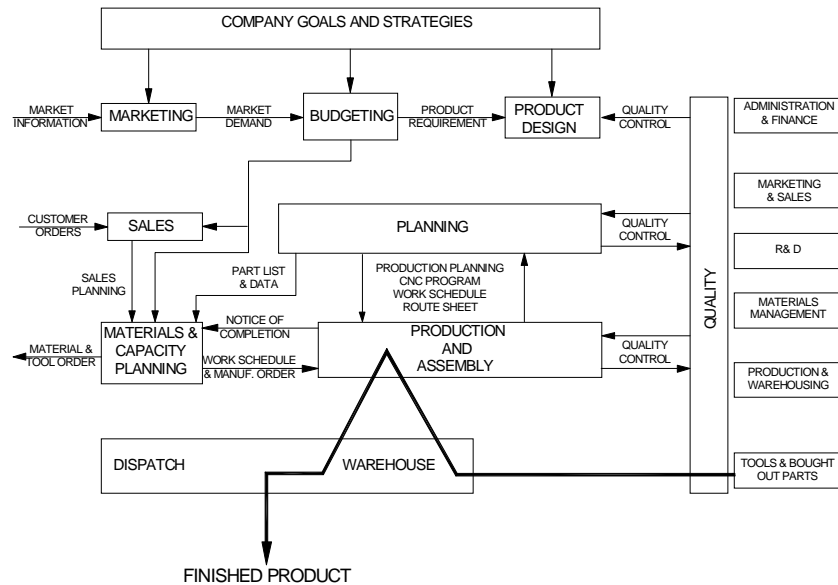


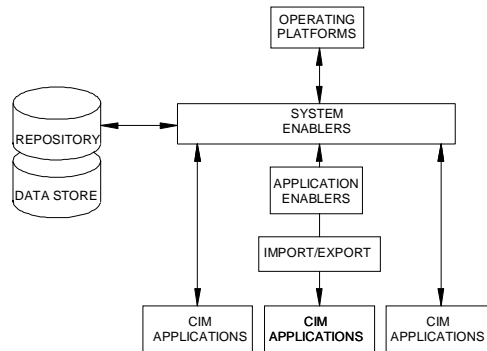
Fig. 18.5. CIM Model of DEC

## 18.6 THE IBM CONCEPT OF CIM

The IBM CIM architecture facilitates the integration of an enterprise's business processes and information requirements and introduction of technologies and practices like downsizing, distributed processing, and client-server implementation. The investments made in the existing systems are preserved and leveraged through provisions for sharing existing data and applications.

Figure 18.6 illustrates the main components of IBM CIM architecture. This defines a level of common services for CIM solutions and enablers, which assist in the integration of data and processes among applications, including those on platforms in different geographical locations. Enablers are of two types:

- (i) **Systems enabler:** This simplifies integration by establishing an infrastructure of common system services to store and manage data, send and receive data, present data view to users and applications, and manage workflow among applications.
- (ii) **Application enabler:** The application enablers provide a broader range of integration of services. They provide additional services for families of applications that can be based on the services provided by the system enablers at the enterprise level. This provides a high degree of independence from computing platforms and applications in data sharing.



**Fig. 18.6 The IBM CIM Architecture**

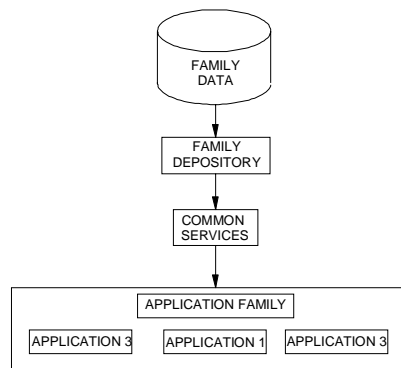
**18.6.1 REPOSITORY AND DATA STORE**

The IBM CIM architecture uses operational depositories and data stores to manage an enterprise’s data. This contains shared data elements, and data definitions recognized throughout the enterprise. Operational repositories provide access to shared data for users and applications. They also enable the creation of enterprise-level information store and provide knowledge for benchmarking and continuous improvement.

**18.6.2 LEVELS OF INTEGRATION**

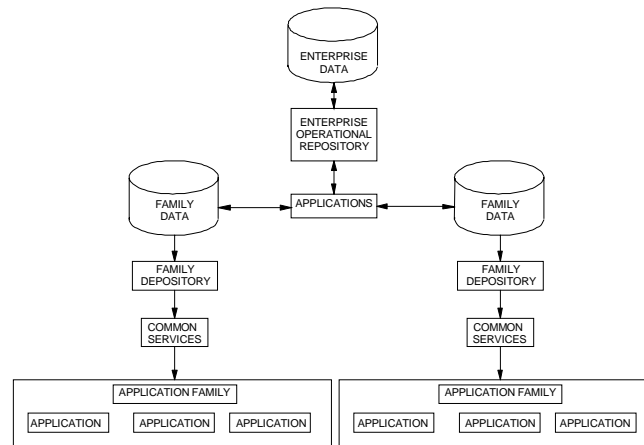
There are four levels of integration.

- (i) **Integration within application families:** The objective of this level is to optimize each application family within itself. This helps to promote a focused approach to the implementation of a solution to a specific class of business problems. These are functionally organized around strategic business functions such as engineering, R&D, production planning, manufacturing, etc. Figure 18.7 shows the structure of an application family. The application solutions integrated within the family have a shared data model.



**Fig. 18.7 An Application Family**

- ii. **Interoperability among application families:** The objective of this level is to take advantage of distributed computing, client-server technology and database management. This reduces workload and improves efficiency in the use of multiple application families. It supports the automation of the most frequently used interaction between application families. The application families assume client and server roles as appropriate for the interaction between them. The use of open communication mechanism at this level allows heterogeneous systems to share the data. This level also supports data modeling. Data modeling enables the users to store information about their data and information about the relationship between the data. This will help the enterprises to become more flexible and respond dynamically to changing application requirements.
- iii. **Data and workflow integration:** Integration of data and processes enables automation of non-computer resources and application functions. This is illustrated in Fig.18.8. Task control is extended to the complex business processes based on process models. At this level the system can assist users to efficiently accomplish their tasks between application families.

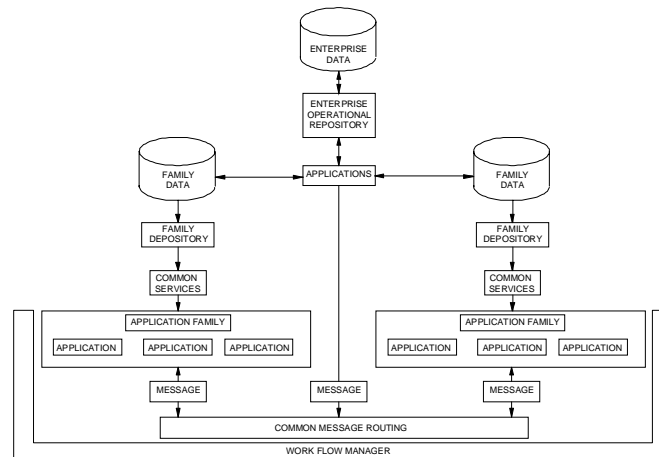


**Fig.18.8 Data and Workflow Integration**

Integration of data and workflow enables the co-ordination of business processes in more than one family. At this level users can share access to processes across the boundaries of organizations, functions and disciplines, as well as information.

- iv. **Enterprise optimization:** This level of integration combines environments for modeling, application development and installation, and run-time operations into a single environment. Enterprise optimization anticipates that repository technology will have evolved to the point where enterprise level data and process integration can be supported. Figure 18.9 shows enterprise optimization. At this

level of integration application families merge into a common pool of function and resources.



**Fig.18.9 Enterprise Optimization**

## 18.7 PRESENT SCENARIO

The manufacturing industries have to deal with a number of challenging issues to day. Some of them are:

- i. **Rising customer expectations:** Customers demand more and more customized products of higher functionality and quality and short delivery times.
- ii. **Globalization:** Trade barriers between countries are fast disappearing. The consequent globalization of the market introduces considerable challenges.
- iii. **Developments in technology:** New technologies make processes and products obsolete faster than ever.
- iv. **Access to information:** The Internet has made it possible to access information from any part of the world quickly. This provides both opportunities as well as challenges. This also enables every one access to the latest technology.
- v. **Environmental concerns:** As more and more countries develop industrially, there is more and more pressure on the environment and the raw materials.
- vi. **Intense competition:** The emerging scenario is that of intense competition among manufacturing companies.

The manufacturing companies will have to therefore develop their strategies for the future considering the above challenges.

In order to make the manufacturing companies to be capable of meeting the future challenges several strategies are being tried out. Some of them are discussed in the subsequent chapters.



**QUESTIONS**

1. Discuss the changes in product development approaches and their influence in shaping manufacturing strategies.
2. Compare different CIM Models with particular reference to the flow of information.
3. Analyze the manufacturing operations of a company and prepare a report as to how the IBM CIM model could be implemented in the company.

# FLEXIBLE MANUFACTURING SYSTEMS

*A Flexible Manufacturing System (FMS) is an integrated approach to automating a production system with a view to accommodate fast response to product changes. The primary nature of an FMS is that it is a computer-controlled manufacturing system that ties together storage, manufacturing machines, inspection, tooling and materials handling equipment. The FMS is designed to be flexible so that it can manufacture a variety of products at relatively low volumes, with minimum lead time between product changes.*

## 19.1 INTRODUCTION

Intense competition in the global market for mechanical parts manufactured on machine tools and other metal working equipment has compelled manufacturers to reduce delivery times and quote competitive prices even for relatively small orders. In many situations, manufacturers have to deliver customized products to the consumers. The batch size is ever-decreasing, and the need to meet specific customer needs calls for considerable flexibility in the working of the manufacturing system.

In this situation, the requirements that a modern manufacturing facility has to meet can be detailed as follows:

- High productivity for all batch sizes, large or small
- Shorter throughput times
- Lower storage costs
- Reduced labour if not altogether avoiding labour
- Reduced handling
- Flexible production system to incorporate product changes at short notice to meet customer's specific requirements
- Sensing and taking care of such eventualities like tool breakage.

Conventional high volume production facilities such as automatic equipment and transfer lines do not fulfill these requirements. This provided sufficient reason for

manufacturing engineers to turn attention to alternative approaches to manufacturing. Flexible manufacturing cells and flexible manufacturing systems have been evolved to meet the requirements listed above.

The functions of many manufacturing equipment have already been automated through the use of CNC and PLC. The next stage is to automate the wider manufacturing environment comprising the following activities:

- Management of resources
- Storage, preparation and transport of raw workpieces and finished components
- Acquisition, processing and evaluation of production data
- Inspection of workpieces and continuously monitoring the performance of production equipment
- Testing of products
- Developing software to control all the above operations.

In such a process of integrated automation it is necessary to combine a number of machines, both mechanically and in terms of data processing into a closely linked manufacturing unit. In this way, highly automated manufacturing units (cells) are created which are capable of handling a number of different workpieces without interruptions due to operations like setting up workpieces, tool change, inspection etc.

Monitoring and process correction facilities through appropriate sensors are also part of the system so that operator intervention is kept to a bare minimum.

Manufacturing cells normally contain 1 to 4 production machines. In addition to various “service machines” such as measuring machines and washing machines) and transport systems like automated guided vehicles, rail guided vehicles and conveyors for the workpieces and for the tools.

The cell computer simultaneously controls the manufacturing operations within the manufacturing cell.

## 19.2 SUBSYSTEMS OF FMS

There are three major subsystems in FMS:

- (i) Computer-controlled manufacturing equipment (e.g. numerically controlled machine tools, robots, gantry loaders, palletizing systems, washing stations, tool pre-setters, in-process inspection systems etc.)
- (ii) Automated materials storage, retrieval, transport and transfer system
- (iii) Manufacturing control system (including both machine tool, tool and logistics control)

Some FMS's have additional subsystems. For example, in a machining application there may also be systems for presetting tools, storing and retrieving tools, disposing of chips and cutting fluids, washing and inspection workpieces. These subsystems must be linked together to achieve integrated manufacturing operation.

### 19.3 SCOPE OF FMS

Although this was initially developed for machining applications, the concept of FMS has subsequently been used in a variety of other manufacturing applications, such as:

- Assembly of equipments
- Semiconductor component manufacturing
- Plastic injection moulding
- Sheet metal fabrication
- Welding
- Textile machinery manufacture

Such systems have proved to be practical and economical for applications with the following characteristics:

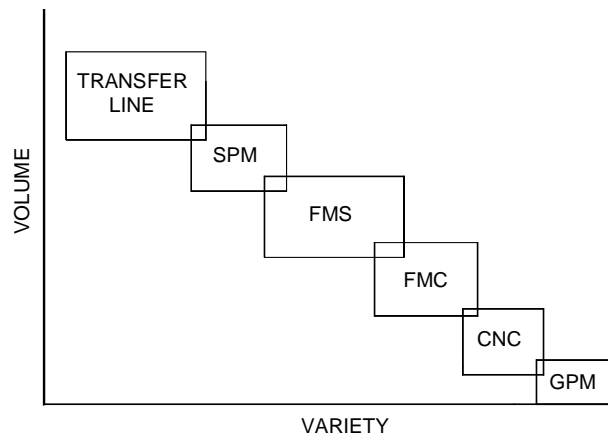
- Families of parts with similar geometric features that require similar types of equipment and processes
- A moderate number of tools and process steps
- Low to medium quantities of parts
- Moderate precision requirements

### 19.4 FMS COMPARED TO OTHER TYPES OF MANUFACTURING APPROACHES

One-off and low volumes of production are normally carried out by conventional general purpose machine tools. When the number of parts in a production run is more it is called batch production. A batch production shop is best suited for small quantities of many different types of parts. The very nature of production makes the operation of a job shop less efficient than an automated production line.

Since the job shop must be provided the greatest degree of flexibility, most of its operations are manual. They are normally equipped with general purpose CNC machine tools. Hard automation with dedicated equipment is best suited for the production of very large quantities of identical parts. Production of automobile components in a transfer line falls under this category. A large portion of the manufacturing industry involves the intermediate level of batch operations that lend themselves to the FMS approach. In this case volume is less but varieties are more.

FMS thus basically attempts to efficiently automate batch manufacturing operations. They are an alternative that fits in between the manual job shop and hard automation. FMS is best suited for applications that involve an intermediate level of flexibility and low or medium quantities. Fig. 19.1 shows the different types of production systems and it can be seen from the figure that FMS fits into the intermediate range of production. General purpose machines can accommodate a large variety of parts. They are manually



**Fig. 19.1 Types of Production Systems**

operated and therefore production volumes are low. CNC machines can accommodate variety but the production volume is less as the machines are not optimized for the highest productivity for a specified type of job. It can be seen that FMC and FMS satisfy both variety and volume equally well. If we take special purpose machines, variety is much restricted. Transfer lines are dedicated usually to manufacture a component and hence can be said to have the minimum variety.

## 19.5 TYPES OF FMS

FMS has been classified in several ways. Some of these classifications are still valid but the discussion in this book is restricted to three basic types:

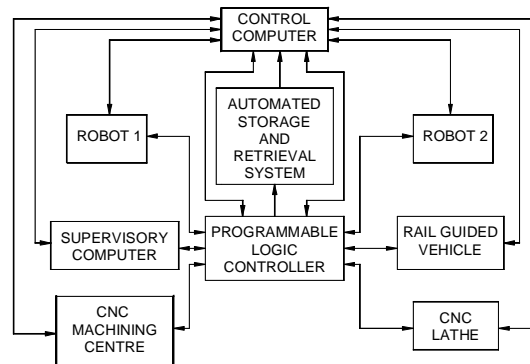
### 19.5.1. FLEXIBLE MANUFACTURING CELLS (FMC)

The simplest, hence most flexible type of FMS is a flexible manufacturing cell. It consists of one or more CNC machine tools, general purpose or of special design interfaced with automated material handling and tool changers. FMC's are capable of automatically machining a wide range of different workpieces. They are usually employed in one off and small batch production as independent machining centres, but are frequently the starting point for FMS.

A turning centre fitted with a gantry loading and unloading system and pallets for storing work pieces and finished parts is a typical flexible turning cell. If the turning centre is incorporated with either in-process or post process metrology equipment like Renishaw probes or inductive measuring equipment for automatic offset correction, the productivity of the system improves and wastage due to rejection is reduced. Automatic tool changers, tool magazines, block tooling, automatic tool offset measurement, and automatic chuck change and chuck jaw change etc. help to make the cell to be more productive.

One or two horizontal machining centres with modular fixturing, multiple pallets, advanced tool management system, automatic tool changer, automatic head changer or automatic magazine changer, robots or other material handling systems to facilitate access of the jobs to the machine also constitute a flexible machining cell.

An FMC can also comprise a turning centre, machining centre and pick and place robots or other materials handling systems. Fig. 19.2 shows the block diagram of a flexible manufacturing cell. This consists of a CNC lathe, a machining centre, a small automatic storage and retrieval system, two robots for loading and unloading the machines and a small rail guided vehicle to carry the component from one machine tool to another. The system is controlled by a PLC and a couple of personal computer.



**Fig. 19.2 Flexible Manufacturing Cell**

### 19.5.2 FLEXIBLE TURNING CELLS

One of the most important advantages of CNC machines is their flexibility. The flexibility in this particular context means that these work centres enable the production of components in short batches. The production can be planned to meet immediate requirements because the change over time is short. In order to enable the production set up to change over from one component to another component in the shortest possible time, several technological features have to be added to the turning machines. This section describes some of these important features.

There are several ways to cut down idle time and component change over time and improve the productivity and flexibility of CNC turning centres.

Flexible turning cells generally employ turning centres instead of CNC lathes. The availability of C-axis and the live tools in the turret enable the process designer to complete not only turning but also operations like milling, off-centre drilling, tapping, and helical groove cutting etc in one set up. This means that all operations required to completely machine a component can be carried out in one set up itself.

The relatively high cost of CNC machines means that the machine hour rate is several times that of conventional machines. This necessitates not only increasing the utilization

by cutting down idle time but also working on all the three shifts of the day as well as during holidays. This calls for a high degree of automation.

By using automatic part changer, automatic tool changer and adopting process automation through sensing and feed back devices like tool breakage sensors, automatic tool length offset compensation, in-process or post-process gauging and program correction, automatic chuck changing and chuck jaw changing, it will be possible to achieve fully automatic unmanned machining.

#### **19.5.2.1 Gantry (Robot) for Loading and Unloading (Automatic Part Changing)**

A gantry device, a type of robot is used for loading raw workpiece (blank) and unloading finished components. The raw materials are loaded in a pallet and delivered in the loading bay of the gantry. A separate pallet is used to receive the finished component. The loading arm of the gantry robot picks up a raw blank and moves to a location near to the chuck. As soon as the machining of the component is over, it swaps the raw blank and the finished part. The finished part is returned to the pallet while machining starts on the new work piece. The gantry robot picks up another raw part and positions itself near the chuck, ready to swap it with the job that is currently being machined. Many manufacturers supply gantry robots in India which can be fitted to the turning centres.

#### **19.5.2.2. Automatic Tool Change Systems**

There are several tooling systems available for automatic tool change systems in turning centres. A brief description of some of the features of a typical tooling system is included here.

The tooling system consists of:

Tool heads

Tool adapters

Tool head locking mechanism

Tool head changers

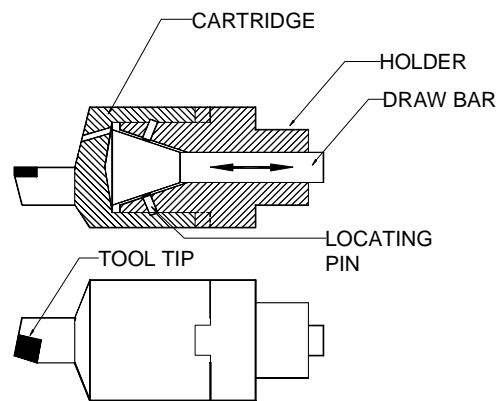
Tool head magazines

Probe for tool head

Tool breakage sensor

Probes for workpieces

**Tool Head:** The tool head on which the insert is mounted is basically cylindrical in shape and is provided with a cylindrical bore and tenon slots on the face for location. The basic holder has corresponding spigot and tenons to receive and locate the tool head. The basic holder also carries a draw bar which actuates four radially arranged inclined pins (Fig. 19.3)

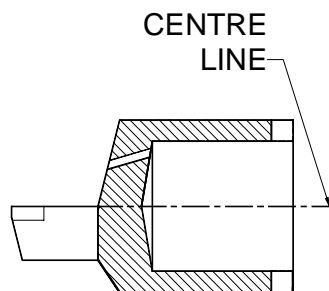


**Fig. 19.3 Tool Head**

The rigid cylindrical spigot not only helps to locate the tool head but also serves as a support against the cutting forces and is equally strong in resisting forces acting in any direction. Axial loads are transmitted to the holder through the plane contact face. The tenons prevent rotation of tool head and also help in indexing the tool holder by 180°.

The following design features of the tool heads make them versatile and help in trouble-free operation:

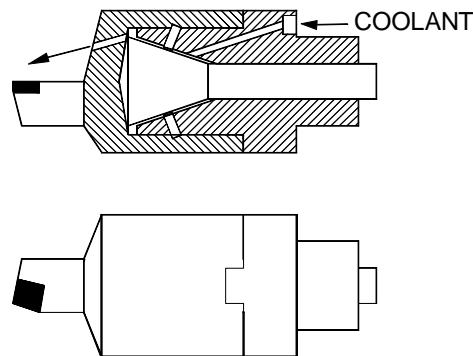
- (i) Tool heads are of light weight and very compact in size. This helps in reducing size of magazine.
- (ii) The cutting edge of the tool head lies on a central plane of the tool head (Fig. 19.4). This means that the same tool head can be used for both external and internal machining. The same tool head can also be fitted upside down. This design feature brings about considerable reduction in inventory costs. Of course, different basic holders are often used for external and internal machining.



**Fig. 19.4 Tool Head and Cutting Edge**

- (iii) All the tool heads are designed for internal coolant supply. Coolant is fed through the holder of the tool head. The coolant hole in the tool head directs a continuous stream of coolant at the cutting edge. (Fig. 19.5)





**Fig. 19.5 Coolant Supply**

- (iv) The system usually consists of three basic sizes to accommodate different sizes of inserts and different loads. These tools can withstand cutting load which varies from 12 kN to 50 kN depending upon the size of the spigot.
- (v) Repeatability and accuracy of mounting measured at the tool nose is exceptionally high with same tool head. With different tool heads some deviation may occur owing to the tolerances on insert seat and insert dimensions. All heads and holders are made to closer tolerances than normal tool holders eliminating the need for tool offset compensation in roughing operations. Since these tools are not pre-set, finishing operations require tool offset compensation.
- (vi) A wide range of tool heads is available for internal and external applications. Besides tool heads for turning, copy turning, facing, threading, grooving and part-off, collet chucks are available for holding small diameter drills, reamers etc.

**Tool Adapters:** Following are some of the types of tool adapters commonly used:

- (i) Tool adapters with round shank
- (ii) Tool adapters for square turrets with prismatic shank
- (iii) Tool adapters for rotating tools. These units are mounted peripherally on a tool holder. A hydraulic motor with steplessly variable speed drives the tool through a clutch. Rotating tools are held in a collet chuck and can be automatically replaced.

When changing the tools, the tool head must be properly positioned on the tool adapter for reliable automatic locking by actuating the draw bar. This is monitored by a back pressure measuring device integrated in the tool adapter.

As the contact face of the tool head approaches the tool adapter, back pressure increases, reaching a maximum level when full contact is made, whereupon a signal is emitted to clamp the tool and start the machining operation. An air stream cleans the spigot and blows chip fragments away at the time of inserting the tool head.

**Tool Head Locking Mechanism:** The tool system in a FMC is available for three levels of automation. In manual operation tool heads are changed and locked by hand; in semi-

automatic operation tools are changed by hand but locked and released by a motor ; in fully automatic operation locking/releasing, tool changing and process monitoring are automatic, necessitating the use of appropriate magazine, tool changer, tool locking and process monitoring equipment.

**Tool Head Magazines:** Tool magazines accommodate all the tools required in the machine for a given workpiece or a group of workpieces. Magazine capacity ranges from 24 to 120 tools. Generally, 30 to 60 tool stations are sufficient for one shift. As discussed earlier, tools are held in the magazine by short spigots. Simple mechanical features locate the tool and prevent it from rotating or falling off. This concept offers the advantage that used tools can be deposited in vacant stations.

Various designs of tool magazines are available, e.g. drum, rail or disc types. In setups where the magazine is not driven, the tool changer will execute all movements.

**Tool Head Changer:** Tool head handling can be effected, for instance, by a hydraulic tool changer attached to the lathe's longitudinal slide by an intermediate member. Depending on the workpiece and the machining operation, various standard designs are employed.

The simplest set-up is for shaft work only, where all tools are for external machining and mounted on radial tool holders. The tool changer then consists of one rotational and two translational hydraulic units.

Chucking work generally requires the use of radially mounted external tools as well as axially mounted internal tools. Owing to the additional 90° turn required the tool changer comprises two rotational and three translational units. Any industrial robot meeting these requirements can be used as a tool changer. The cylindrical spigot on the tool holder features an entering groove which permits trouble-free coupling of tool head and tool holder.

**Probe for Tool Head:** Besides tools, magazines and grippers, the tooling system also includes all the sensors required in automatic operation for measuring and monitoring the process. An interface circuit transduces the signals received from a sensor into control pulses for the CNC system. In addition to reliability, integrated microelectronics also offers short response times, an advantage for quicker tool breakage detection.

Any tool in the lathe can be checked for offset along the X and Z axes. The tool to be checked is taken to the probe, like a Renishaw LP-2 signal emitting type sensor. The signal emitted is processed at the interface circuit and passed on to the CNC system which then compares the actual value with a preset value and automatically compensates for any variation in tool offset. Pre-setting of tools and fixtures is therefore rendered superfluous.

**Tool Monitoring:** Completely automated machining calls for continuous monitoring of tool to sense end of tool life due to gradual wear, breakage of tool due to chipping or collision in order to avoid further damage. Tool monitoring systems help in sensing above events and in avoiding damage to tool and reducing down time of machine.

A tool monitoring system consists of three individual components for sensing collision, breakage and wear.

All these systems work according to simple and reliable principle of measurement. During machining, cutting forces are continuously sensed through a strain transducer mounted on the machine. Any variation during the process of machining leads to a change in the cutting force which is sensed by the strain transducer. If the previously set value is crossed, then the device gives within a few milliseconds an impulse for the feed to stop.

The system consists essentially of the strain transducer, signal conditioning and processing electronics and the machine interface. The piezo-electric strain transducer is mounted on that part of the machine which is subject to maximum deformation. This is usually the turret housing. The signals picked up during machining operation are evaluated continuously by the microprocessors in the system.

**Collision Monitor:** Automatic collision monitoring starts with the establishment of a threshold value of forces. The machine tool is first run through the machining programme for the specific workpiece. The transducer measures the forces that are set up and gives a digital read-out of the maximum value. At the press of a button, this value plus a safety allowance is transferred to the decode switch and acts as a force threshold for the monitoring process. When the programme is run again the collision control system automatically monitors the machine for collision. If process data exceeds the preset threshold, a signal is emitted to shut down the feed motor within 3 milliseconds. At the same time the operator is alerted by visual and audible warning signals.

The turning centre programme cannot be resumed until the fault signal has been acknowledged, either manually via a push-button or by the control system via the clear (CLR) signal. If cutting parameters are changed substantially, a new cut-out threshold has to be established. Under certain conditions the system can even detect tool breakage, for example if the force setup by breakage exceeds the preset threshold.

**Continuous Wear:** The turning centre operation can be made much more cost-effective by the wear control system. By determining when a tool is worn, the risk of scrap production as a result of blunt tools is eliminated. This also reduces the risk of cutting edge breakage. The monitoring strategy for wear control is based on the measurement of the rise in force over tool life. This rise is dependent on a number of parameters which cannot be defined in advance. They have to be learnt by the system in a teach-in phase covering the useful life of a standard reference cutting edge. Instead of the teach-in-phase the operator can also key in a rise-in-force value or call up from memory a previously established value.

During machining, the wear monitoring unit continuously calculates the extent of wear of each tool in use and displays the value. The operator knows at a glance how much time remains until the next tool change. The system thus permits timely tool setting and helps effective production scheduling.

After a workpiece has been machined the relevant tool is checked for wear. A wear message appears on the display giving the relevant tool number. As soon as this message is acknowledged a new message is displayed instructing the operator to change the tool. Only when tool replacement has been effected and confirmed can production be resumed.

**Breakage Monitor:** Breakage monitor is a system offering versatility in tool monitoring. It provides automatic detection and programmable response to breakage, collision, spalling and tool vibrations.

To ensure complete reliability in performing all control functions the tool breakage monitoring and control system employs three monitoring strategies. The first involves a safety limit. The high force signal caused by collision exceeds this limit and the feed motor is shut down immediately. Collision is thus detected effectively and automatically.

The second strategy involves the system's microprocessor monitoring every cut and comparing it with a predetermined force value. If this value is exceeded the feed monitor is stopped instantaneously.

In a third strategy the system looks out for specific events which are typical of tool breakage. When a tool breaks sudden high-frequency peaks occur in the components of the cutting force in radial and feed directions. These peaks, which do not occur in normal operation, are due to particles of the shattered tool becoming jammed between workpiece and cutting edge. As they break free the cutting forces drop briefly to zero. The breakage monitoring system, working with preset upper and lower tolerance limits, responds immediately when either of these limits is transgressed and within 2 milliseconds emits a signal to stop the feed. By means of a special stop module the feed drive is shut down within 20 milliseconds.

**Probe for Workpiece Gauging:** The workpiece gauging probe permits in-process workpiece gauging with integrated tool offset compensation via the CNC system. Both inside and outside diameters can be measured as well as lengths. Gauging is done by a Renishaw LP2-3D probe with a replaceable stylus. The probe is mounted in a specially designed head and placed on an external or internal tool holder as required. During machining the probe is stored in the magazine for protection. The signal is transferred to the interface either by cable or via contactless induction coils or through infrared emission. The probe is calibrated with the aid of a reference plane in the machine.

### 19.5.3. FLEXIBLE TRANSFER LINES (FTL)

Flexible transfer lines are intended for high volume production. A part in a high volume production may have to undergo large number of operations. Each operation is assigned to and performed on only one machine. This results in a fixed route for each part through the system. The material handling system is usually a pallet or carousel or conveyor. In addition to general purpose machines, it can consist of SPM's, robots and some dedicated equipment. Scheduling to balance the machine loads is easier. Unlike conventional transfer lines, a number of different workpieces can be manufactured on the FTL. The resetting procedure is largely automatic.

### 19.5.4. FLEXIBLE MACHINING SYSTEMS

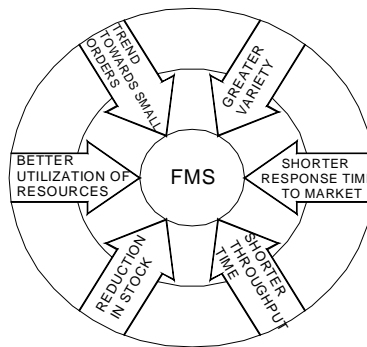
Flexible Machining Systems consists of several flexible automated machine tools of the universal or special type which are flexibly interlinked by an automatic workpiece flow

system so that different workpieces can be machined with the same machine configuration. The characteristic feature is the external interlinkage of the machines, unrestricted by cycle time considerations. Different machining times at the individual stations are compensated for by central or decentralized workpiece buffer stores. Flexibility is applied to machines because of CNC control and flow of products from one machine to another which is possible through flexible transport system.

Flexibility is characterized by the system's ability to adapt to changes in the volumes in the product mix and of the machining processes and sequences. This means that a FMS will be able to respond quickly to changing market and customer demands.

### 19.6 BENEFITS OF FMS

FMS's are designed to provide a number of advantages over alternative approaches (Fig. 19.6). These are listed below:



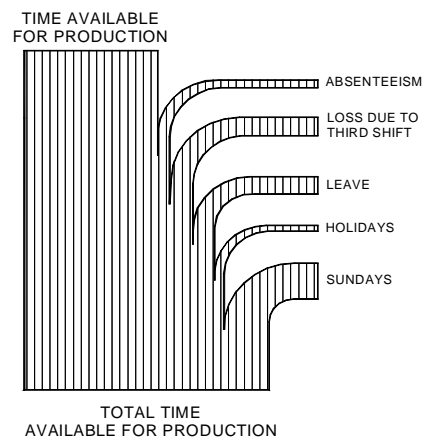
**Fig. 19.6 Benefits of FMS**

- Reduced cycle times
- Lower work-in-process (WIP) inventory
- Low direct labour costs
- Ability to change over to different parts quickly
- Improved quality of product (due to consistency)
- Higher utilization of equipment and resources (Utilization better than stand-alone CNC machines)
- Quicker response to market changes
- Reduced space requirements
- Ability to optimize loading and throughput of machines
- Expandability for additional processes or added capacity
- Reduced number of tools and machines required

- Motivation for designers to add variations and features to meet customer requirements.
- Compatible with CIM

Some of these advantages can lead to significant cost savings. Direct labour can be eliminated almost entirely. Cycle time and WIP can be reduced to a fraction of what is normally experienced in a manual operation. An FMS is designed to have the production machines working most of the time rather than standing idle.

This can be explained with the help of Fig. 19.7. On any manually controlled work centre, the total time available for production per year is 8760 hours. Out of which the company loses 14.3 % of the time on account of Sunday being a weekly holiday. Paid holidays result in production loss of roughly 1.5%. An employee may also be eligible for paid leave (casual leave, earned leave etc.) and this may reduce the available working hours by 8%. The efficiency of production in the third shift is usually less and the production loss due to it is about 14% (assuming only 50% of the normal efficiency in the third shift). In India, a major cause for loss of production is employee absenteeism due to medical or other reasons. A factory employee is eligible to avail upto 90 days leave a year, enjoying the benefits from Employee's State Insurance. The average absenteeism in many industries varies. If we assume that the loss of production due to absenteeism is approximately 7%, the net available production time is only 55%. Assuming an efficiency of production of 80%, the work centre time utilized comes down to 44%.



**Fig. 19.7 Loss of Production Time**

In the case of conventional manually operated metal cutting machines, the actual time utilized for removal of material is about 30-35% of the working time. The rest of the time is spent on non-productive operations like setting up of work and tools, inspection or procuring tools etc.

In the case of efficient operation of CNC machines this percentage increased to 80 to 85%. In FMS, one can achieve as high as 90-95% efficiency. Another important feature of

FMS is that an FMS can produce parts even if the employee is absent or even if it is a holiday. The significance of FMS must be apparent from this fact.

An automated material handling system and a computer-based production scheduling system are needed to keep the machines fed with parts. FMS uses computer automation techniques to lower the overall cost of production operations.

## 19.7 MAJOR ELEMENTS OF FMS

Each of the major subsystems in an FMS performs a number of functions and is dependent on the others to make the entire system work. The functions will vary, depending upon the type of equipment and manufacturing operations involved.

### 19.7.1 PRODUCTION EQUIPMENT

The production equipment used in FMS depends upon the product manufactured.

- (i) **FMS for sheet metal work:** The work centres used in sheet metal FMS include turret punch presses, laser machining centres, press brakes, guillotines etc. A typical FMC consists of sheet stacking system, sheet unloading device, sorting conveyor, turret punch press, right angle shear, loading device and automatic storage.
- (ii) **FMS for machining:** This type of FMS typically has a number of machining centres and/or turning centres to provide general purpose machining capabilities. Machining centers offer the greatest flexibility, since they can perform many different machining operations. (e.g. milling, drilling, and boring). This is made possible by a tool-changing system that is either built into or supports the machining centre. A part can therefore undergo multiple machining processes at a single workstation. Special purpose machines may also be included in the FMS to perform operations which are unique or require more efficiency (e.g. turning, grinding). Washing machines and inspection machines also form the equipment of FMS.

The family of parts which the FMS is designed to produce will determine the capabilities required from the machine tools (e.g. accuracy, size, power etc). Details of the CNC machine tools are given in Chapter 12.

### 19.7.2 SUPPORT SYSTEMS

Automated machine tools typically require several systems to support their operation. The tools required to perform the multiple processes of a machining centre or a turning centre may be stored in magazines at each machine or in central tool storage. Local magazines provide fast access as well as backup capability but in a large FMS a central tool facility may be more efficient. Centralization not only permits the total number of tools to be minimized; it also provides the opportunity to perform additional functions automatically, such as:

- (i) Measurement of tool wear
- (ii) Tool pre-setting
- (iii) Tool regrinding, repair and maintenance
- (iv) Replacement of broken or worn tools

Many automated machine tools have built-in systems to monitor tool wear and detect tool breakage. They may use probes or non-contact techniques such as acoustic emission for this purpose. When a tool needs replacement, the machine can signal the tool room for the delivery of a replacement. This may be performed by an AGV or gantry set up or RGV.

Elaborate tool management support is an integral part of FMS software. With this software, operating personnel can have effective centralized control of a large tool inventory.

Automated machining operations also need to have the chips cleaned off the workstation and the workpiece. This may be performed by robots or special washing stations. Cleaning may involve turning the workpiece over, vacuuming and washing.

### 19.7.3 MATERIALS HANDLING SYSTEM

- A FMS typically needs several materials handling systems to service the machines.
- A transport system to move workpieces into and out of the FMS (e.g. overhead conveyors, gantry systems, AGV's, RGV's)
- A buffer storage system for queues of workpieces at the machines (e.g., pallets)
- A transfer system to load and unload the machines (e.g. robots, transfer fixtures)

For these systems to work effectively, they must be synchronized with the machine operations. The location and movement of workpieces must be tracked automatically. This is done by using sensors on the materials handling system and workstations.

They may be either contact devices (e.g. switches) or non-contact devices (e.g. optical, RFID tags or proximity devices).

#### 19.7.3.1 Automatic Guided Vehicles (AGV)

AGV is one of the widely used types of material handling device in an FMS. These are battery-powered vehicles that can move and transfer materials by following prescribed paths around the shop floor. They are neither physically tied to the production line nor driven by an operator like forklift. Such vehicles have on-board controllers that can be programmed for complicated and varying routes as well as load and unload operations. The computer for the materials handling system or the central computer provides overall control functions, such as dispatching, routing and traffic control and collision avoidance. AGV's usually complement an automated production line consisting of conveyor or transfer systems by providing the flexibility of complex and programmable movement around the manufacturing shop.



### ***Advantages of using AGV systems in FMS***

- (i) ***Flexibility:*** The route of the AGV's can be easily altered, expanded and modified, simply by changing the guide path of the vehicles. This is more cost effective than modifying fixed conveyor lines or rail guided vehicles. It provides direct access materials handling system for loading and unloading FMS cells and accessing the automated storage and retrieval system.
- (ii) ***Real time monitoring and control:*** Because of computer control, AGV's can be monitored in real time. If the FMS control system decides to change the schedule, the vehicles can be re-routed and urgent requests can be served. AGV's are usually controlled through wires implanted on the factory floor. The control is effected using a variable frequency approach.

Radio control, an alternative to in-floor mounted communication lines, permits two way communications between the on-board computer and a remote computer, independent of where the vehicle is i.e. whether it is in the parking place or whether it is in motion. To issue a command to a vehicle, the central computer sends a bit stream via its transmitter using frequency shift keying methods to address a specific vehicle. The signal transmitted from the base station is, therefore, read by the appropriate vehicle only. The vehicle is also capable of sending signals back to the remote controller, to report the status of the vehicle, vehicle malfunction, battery status, and so on.

- (iii) ***Safety:*** AGV's can travel at a slow speed but typically operate in the range 10 to 70 m/min. They have on-board microprocessor control to communicate with local zone controllers which direct the traffic and prevent collisions between vehicles as well as the vehicle and other objects. A bumper is attached to some designs of AGV's to prevent collision.

AGV's may also incorporate warning lights, fire safety interlocks and controls for safety in shops. During design, the use of simulation can help detect whether there are enough vehicles to perform the necessary load, unload and transportation tasks and thus optimize the utilization of the AGV system. Because these vehicles have to work in a tandem with highly organized FMS cells as well as with automated warehouses under computer control, their level of performance will affect the entire efficiency of the FMS.

### **19.7.4 AUTOMATED STORAGE AND RETRIEVAL SYSTEMS**

A key part of any materials handling system is storage. Major advances have been made in recent years to automate the storage and retrieval of product and materials by employing sophisticated materials handling machines, high-density storage techniques and computer control. Such systems come in a variety of forms and sizes depending on the materials handling and storage job that has to be done. They often take the form of automated warehouses which use automatic storage and retrieval systems, conveyors and computers to control the materials handling machines and to track and control the inventory. The characteristics of such warehouses include:

- (i) High density storage (in some cases, large, high-rise rack structures)
- (ii) Automated handling systems (such as elevators, storage and retrieval carousels and conveyors).
- (iii) Materials tracking systems (using optical or magnetic sensors)

In such a storage system, the computer can keep track of a large number of different parts, products and materials and can assign bin locations to optimize the use of storage space. When such a system is tied into the production control system, parts and materials can be replenished as they are consumed on the factory floor, keeping the work in process (WIP) to a minimum.

#### 19.7.4.1. Categories of AS/RS

The automatic storage and retrieval system can be classified into several types. Some of them are:

- Unit load AS/RS
- Mini load AS/RS
- Man-on-board AS/RS
- Automated item retrieval system
- Deep lane AS/RS

#### 19.7.4.2 Basic Components of AS/RS

An AS/RS normally consists of:

- Storage structure
- Storage and retrieval machine
- Storage modules
- Pick-up and deposit stations

#### 19.7.4.3 Special Features of AS/RS

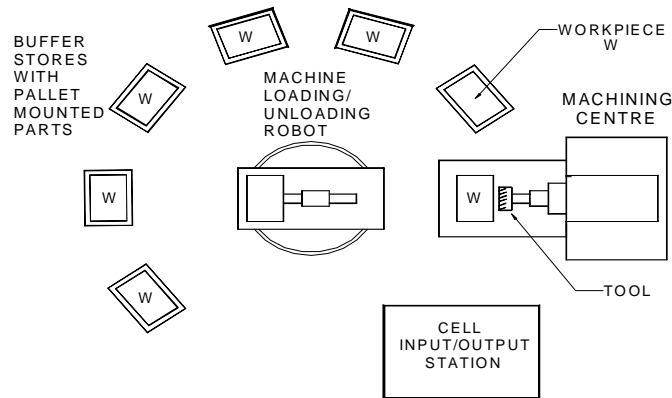
Some of the special features of AS/RS are:

- Aisle transfer cars
- Full/empty bin detectors
- Sizing stations
- Load identification stations

### 19.7.5 BUFFER STORING OF PARTS

In an FMS, parts move from one work cell to another where the various processing tasks are performed. Because of the almost random production facilities of FMS, the destination cell might not always be ready to accept the incoming part and the part has to wait in a buffer store. These and other bottlenecks in the materials handling problems can be successfully

detected by simulation. Buffer stores for parts will always be desirable. Figure 19.8 shows a typical FMC cell layout where buffer stores are used as an integral part of the cell as well as the overall materials handling system.



**Fig. 19.8 Typical FMC Layout**

In the case of turning centres, the machining time may be of the order of a few minutes. A gantry robot is used for loading and unloading the component. It is better to present the raw workpieces in a pallet to the gantry. Finished workpieces can be deposited in another pallet. The empty raw material pallet and the filled finished part pallet will be transported by the AGV.

Buffer store is also recommended for sheet metal items. Machining centres with multiple pallets (2, 4, 8 or more) incorporate adequate buffer capacity to last several hours.

### 19.7.6 CHIP REMOVAL AND WASHING STATIONS

Workpiece cleaning is important, especially before the part goes to the inspection station or assembly station, because un-removed swarf can cause problems during the inspection cycles or assembly.

The swarf removal is done at the washing station of the FMS. The pallet with fixtured part is loaded on to the washing station, where it is located as if it was a table of any other machining station. It is tilted, by a hydraulic mechanism, while being rinsed under high pressure coolant or pressurized air supply. Then, while reverting to its load/unload position, the pallet is blown clean with compressed air. Once the part is clean, it can be taken away by a robot or AGV together with its pallet.

### 19.7.7 COMPUTER CONTROL SYSTEM

The computer control system of an FMS integrates several sub-systems including:

- CNC systems
- Support system controllers

Materials handling system controller  
Monitoring and sensing devices  
Data communication system  
Data collection system  
Programmable logic controllers  
Supervisory computer

This control system must also integrate other computer systems if existing in the factory. The FMS system must also communicate with the following systems:

- The CAD/CAM system which generates the CNC programs for the machine tools
- The shop floor control systems which schedules loading and routing of the work
- The management information system (MIS) system which provides management with reports on the performance of the system

The various controllers and computers can be arranged in the form of a LAN for this purpose.

The type of the supervisory computer depends upon the size of FMS. A powerful server will be adequate as a control computer.

## 19.8 OPTIMISATION OF FMS

An FMS requires considerable investment. Thorough planning and analysis should precede the purchase of a FMS as the FMS should be designed to provide efficient operation.

Following are some approaches which should be considered in order to optimize the overall efficiency and effectiveness of FMS:

- Minimizing the process cycle time:** The process must be designed to minimize machining and handling.
- Maximizing the utilization of each machine:** This can be done by balancing the work load in the system and real time scheduling.
- Use of automated storage systems to keep work ready for machines to process:** The raw work parts must be replenished as and when needed to avoid starving the work centres.
- Provision of adequate sensors for the detection of errors or problems:** This includes the detection of the presence and absence of parts, jamming, tool wear, machine failures, and so on. This can be done with the use of vision systems, limit switches, proximity switches etc. In some cases special sensors like tool monitoring systems are used.
- Backup capabilities:** Redundancy is important in ensuring trouble-free operation of the FMS. The system should be able to run even when failures occur (e.g., use spare tools, provision to isolate defective machines, supply of alternative materials

and transport paths, additional machine capacity).

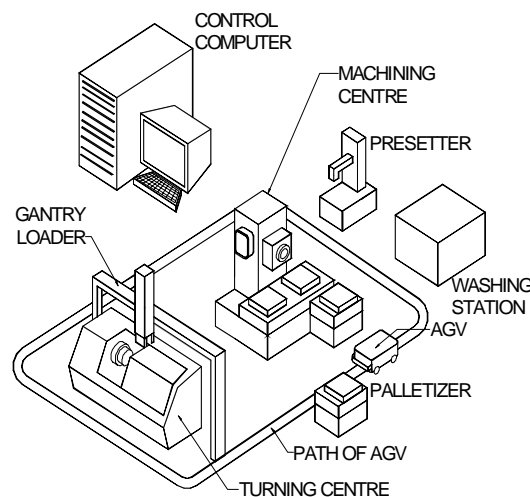
- vi. ***Incorporation of in-process or post-process measurement and inspection techniques:*** These assure product quality and reduce scrap and rework.
- vii. ***Use of identification marking techniques:*** Bar codes and RFID tags are now popular for identifying products as well as components. This permits automatic tracking of workpieces and tools.

A great deal of effort is required to implement FMS. They are complex systems that require careful planning and thorough design. Some of the major tasks in selecting a FMS are:

- Selecting a family of parts that is both similar in design as well as in application. Group technology concepts can be used for this purpose.
- Specifications of the capabilities and performance requirements of the subsystem and total system.
- Bench marking the performance of the alternative proposals.
- Economic justification of the system.
- Determining the size of the system.
- System simulation for optimization.
- Selection of the equipment for the FMS.
- Design of the control systems.
- Selection and training of the personnel to run the system.

### 19.9 OPERATIONAL ELEMENTS OF A TYPICAL FLEXIBLE MANUFACTURING CELL

Figure 19.9 shows a flexible manufacturing cell. The various functional elements of the FMC are discussed below:



**Fig. 19.9 Flexible Manufacturing Cell**

### 19.9.1 THE FMC SOFTWARE

The software system for the flexible manufacturing cell is designed on the basis of the functions the FMC expected to perform. The basic system offers standard interfaces to various software functions. It also handles communication between the individual software modules and between the software modules and any peripherals (printers, other computers).

The CNC controls associated with the cell are accessed via appropriate programs.

The basic system also supports or performs the following functions:

- System generation and parameterization
- System initialization
- Collection and display of error messages
- Log functions

### 19.9.2 TYPES OF DATA ASSOCIATED WITH THE FLEXIBLE MANUFACTURING CELL

A typical FMC system handles four different types of data: Master data, control data, status data and general management data. These data are generated from CAD, CAP and CAM functions. (Fig. 19.10).

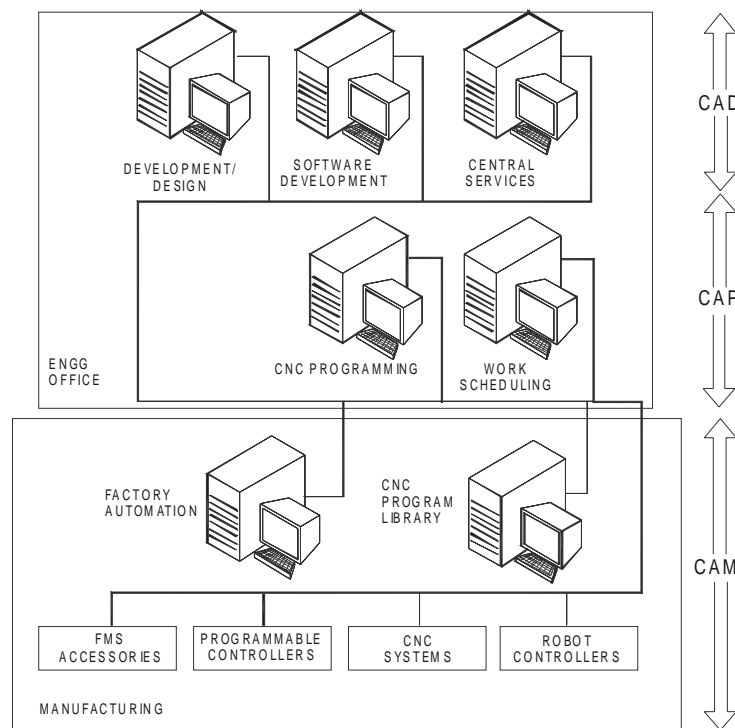


Fig. 19.10 Generation of FMS data

These are discussed below:

- (i) **Master data:** Master data have to be set up only once when the flexible manufacturing cell is put into operation and this comprise:  
System-specific data (related to the architecture of the system) and  
Resource master data which include:
  - (a) Tool master data
  - (b) Workpiece carrier master data (data relating to the workpiece carriers and clamping fixtures)
- (ii) **Control data:** Control data are product-specific data.
  - (a) CNC programs, tool layouts and work schedules (technical control data)
  - (b) manufacturing orders (organizational control data)
- (iii) **Status data:** Status data describes the current situation with regard to resources:
  - (a) Plant status data
  - (b) Resources data
  - (c) Work piece carrier data
  - (d) Tool data
  - (e) Work piece data
- (iv) **Log data:** All operational data and machine data required for later analysis and diagnostics are recorded, evaluated by the software function modules and filled with details of data and time of day. Such data include the following:
  - (a) Machine specific messages  
(e.g. from CNC, PLC, handling devices, transport system)
    - Status and operational messages  
(e.g. NC start, NC end, NC program run time)
    - Alarms  
(e.g. machine fault)
  - (b) Tool specific messages  
(e.g. tool break, end of tool life)
  - (c) NC messages  
(e.g. load NC program)
  - (d) Entry and description of fault by way of a dialogue

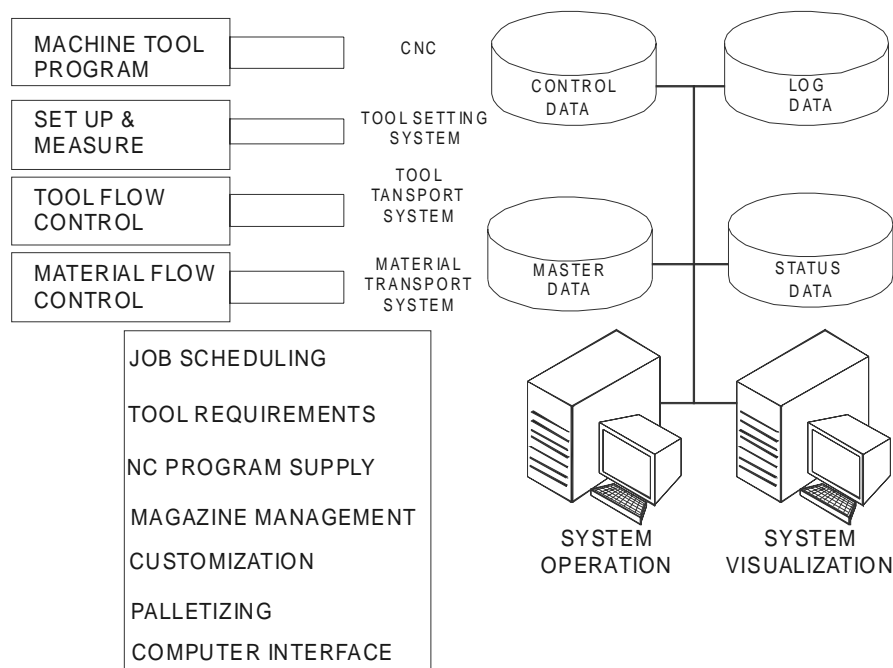
There are system statuses in which the data are not in a defined stated, namely:

- Initial start (all data), and
- Restart after complete or partial loss of data

### 19.9.3. JOB SCHEDULING

Manufacturing orders are entered into the cell computer by the operator interactively. In the input routine, the operator enters the job number, the parts number, the production quantities and deadlines. Manufacturing orders can be completed on a batch basis or may involve a parts mix. Figure 19.11 shows the various FMC functions.

By setting appropriate identifiers it is possible to link manufacturing orders in such a way that parts are finished in the correct order for assembly. The fundamental planning method used is such that with as few workpiece carriers as possible in the cell the machines can be well utilized and throughput times can be kept to a minimum.



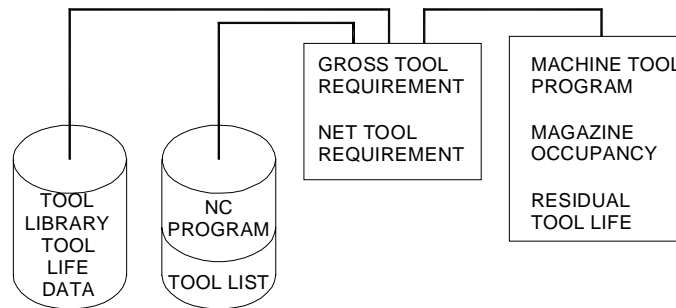
**Fig. 19.11 Various FMS Functions**

Manufacturing orders with the highest priority are the first to be taken up for manufacture.

During the scheduling processes a check is carried out to establish whether the necessary NC programs, workpiece carriers and master data are available. (Fig. 19.12).

If the operator informs the system that the missing resources can be procured in time, the order is then considered to be accepted and scheduled. This scheduling routine is repeated for as long as there is still free manufacturing capacity available. The availability check is repeated prior to start of manufacture.



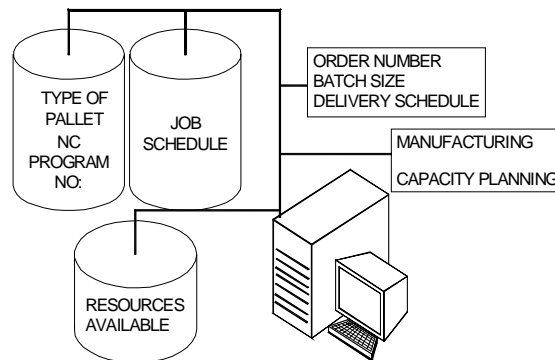


**Fig. 19.12 Data Requirements**

#### 19.9.4. TOOL REQUIREMENTS

Tool requirements planning (Fig. 19.13) for scheduled manufacturing orders are carried out on two separate occasions:

- Immediately after job scheduling and
- Prior to the start of manufacturing



**Fig. 19.13 Tool Data Requirements**

- (i) **Preliminary planning phase:** Tool identification numbers and all the intervention times for each tool application must be taken from the tool lists of the NC programs. The tool lives for all the tools used in the system are stored in the tool reference data management files.

By linking all the relevant data it is possible to ascertain the gross tool requirements; these requirements are notified to the operator (display, printout). The operator confirms that the tools can be obtained in good time.

- (ii) **Final planning phase:** Before manufacturing starts, a requirement analysis is performed which takes into account the residual tool lives of the tools accommodated in the machine magazine. The net tool requirements list and

the list of tools due for release in the machine magazine are printed out in the form of tool loading and unloading lists.

A tool setting unit may be connected to the cell computer as an option. The setting unit is provided with the reference data for the tools to be set. The actual tool data or the tool correction data determined by the unit is transferred online to the cell computer.

For changing the tools, the relevant data are available for the machine tool PLC.

### 19.9.5 SETTING-UP WORK PIECE CARRIER

A work piece carrier consists of a pallet and the workpiece-specific clamping fixtures. At the set up location, the operator is informed for the set up procedures to be performed for the particular workpiece.

If there is no separate setting up location in the system it, setting up takes place at the clamping location. Prior to setting up, the appropriate pallet is selected, blocked and transported to the desired set up location.

If the clamping fixture is mounted and adjusted, the zero offset must be measured. The zero offset data are accepted by the cell computer and if necessary, notified to the machine tool.

### 19.9.6 CLAMPING OR PALLETIZING

More than one clamping or palletizing station can be integrated into a flexible manufacturing cell. A clamping station may consist of a number of clamping locations at which clamping is performed automatically or by the operator. The raw or semi finished job is located in an appropriate pallet and properly clamped. The pallet is designed to enable automatic transfer to the machine table.

- i. **Clamping:** The components for the manufacturing order with the highest priority allocated at the manufacturing order schedule are taken up for clamping. The operator can either accept this order or specify a different order that has already been scheduled.

The material flow control (MFC) facility assigns to the clamping station a workpiece carrier appropriate to the workpieces associated with the selected order. At the end of the clamping process, the MFC routes the workpiece carrier to the appropriate machining equipment.

- ii. **Reclamping:** If the component requires a different type of fixture for a subsequent machining operator, it is reclamped in a suitable fixture.
- iii. **Unclamping:** The MFC facility routes the finished workpiece to the clamping station where the pallet is fitted with a new workpiece appropriate to the manufacturing status.

After all the clamping operations have been completed the workpiece status data are updated. In the case of reclamping and unclamping, "Remachining necessary", or "Reject" may be signaled as quality criteria with respect to the workpiece.

### 19.9.7 MATERIAL FLOW CONTROL

The material flow control facility controls and supervises the transport of the workpiece carriers with the clamped workpiece in the flexible manufacturing cell.

The workpiece carriers are transported by the transport system of the cell between a source station and a destination station. Source and destination station include clamping locations, machine tools, washing and measuring machines, etc.

The transport requests are specified by the station-specific programs (e.g. machine tool program, fixturing programme) to the MFC facility at the end of an operation and processed by the MFC facility according to the FIFO principle (FIRST IN FIRST OUT).

In addition to the stations, each cell normally has storage locations where the workpiece can be held if the destination station is occupied.

If this happens the transport job together with the destination and the priority is preserved. The source station identifier is replaced by the storage location number.

Information on the source and destination is obtained by interpreting the workpiece-specific schedule, in which among other things the sequence of operations is defined.

During transport the status data of the transport system, source and destination stations, workpiece carrier and workpiece are updated by the MFC facility in real time.

### 19.9.8 MACHINE TOOL PROGRAM

In the FMC system the machine tool program undertakes all the tasks arising at the interface to the machine tool. These tasks are online functions, so that each of the machine tools integrated into the FMC system is assigned its own machine tool program.

The machine tool programs process:

#### i. NC functions

- Maintaining a list of the NC programs available in the CNC
- Loading a program by preparing the CNC for loading and activating program transfer via the NC program supply module
- Erasing the CNC memory

#### ii. Tool data

- Reading the tool magazine and forwarding the contents to the tool requirement module
- Forwarding the tool offset data on loading the tool magazine
- Alarms and status messages which lead to the cancellation of automatic processing of the machine tool.

Alarms and status messages are logged by the basic software system. The relevant status data are simultaneously updated.

### 19.9.8.1 Synchronization

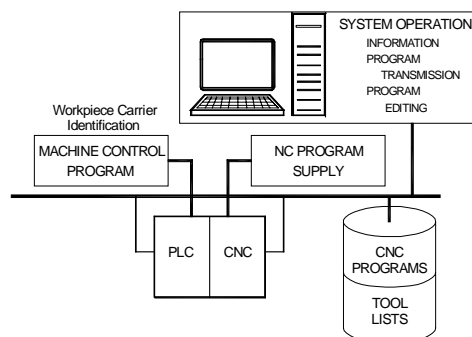
Synchronization must be carried out in the event of a restart for a machine tool in the FMC:

- (i) Resetting the PLC
  - Interrogate alarms and status
  - Cancel NC programs
  - Read tool magazine data
- (ii) Forwarding the information to the relevant program modules
- (iii) Resetting the NC program supply module.

### 19.9.8.2 CNC Program Supply

With the aid of this module, (Fig. 19.14) CNC programs are:

- transferred to the CNC of the cell,
- retransferred from a CNC (updated, optimized programs),
- read from floppy disk or via a host computer interface into the cell computer,
- deleted from the NC program library.



**Fig. 19.14 CNC Program Management**

The CNC programs are held ready by a machine tool program at the interface to the CNC and transferred if the CNC signals that it is ready to receive. Retransmission of updated NC programs is initiated by means of operator inputs on the cell computer.

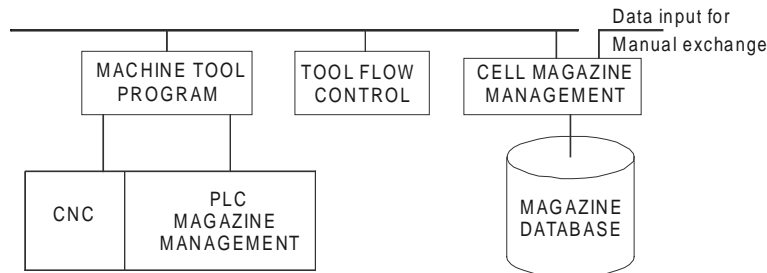
When CNC programs are transferred to the cell computer they are read into an input file, provided with the necessary prefix and management data by the operator interacting with the computer and transferred to the library with a particular CNC program number and references to subroutines and tool lists. The status of the CNC program indicates whether the program is blocked, released for production or whether it is an updated version.

By entering appropriate requests on the operator console lists information relating to:

- All blocked diagrams
- All programs with update versions etc.

### 19.9.9 TOOL FLOW CONTROL

Figure 19.15 shows a schematic diagram of tool flow control. The tool flow control facility processes the bi-directional transfer of tools between the cell magazines. For each machine tool, the tool planning function supplies the tool flow control facility with lists containing the identification numbers of the tools required and the tools those are available.



**Fig. 19.15 Schematic Diagram of Tool Flow Control**

The deciding factor is the time of requirement or the time of tool release for dismantling. Before a workpiece arrives at the machining location of the machine tool a check is carried out to establish whether:

- All the tools required are available in the machine tool magazine, or
- The tools not in the machine tool magazine are available in the cell magazine.

If the necessary tools are not available the workpiece is rejected. If the tools are in the cell magazine, a change of tools is initiated. The time of the change of tools is notified to the relevant machine by the PLC as follows:

From flags set in the NC programs the machine tool PLC knows if there is enough time available for a change of tools. If a flag is set, the tool flow control facility is informed.

#### 19.9.9.1 Tool Changing

The co-ordinates of the tool location are passed to the PLC of the handling device where they are converted into movement instructions. At the same time as the handling device is executing the movement instructions, the PLC of the machine tool positions the magazine for tool changing. Once the new tool has been loaded, the tool that is no longer required can be exchanged and transferred to the cell magazine. A free location is specified by the cell store management facility. Physical tool exchange is accompanied by a magazine management update.

#### 19.9.10 CELL MAGAZINE MANAGEMENT

This program performs the following tasks in the buffer storage magazine of the FMC:

- Location management for the installed tools,

- Machine oriented reservation of tools for current jobs and
- Information functions relating to machine occupancy.

Since normal-sized and oversized tools have different space requirements, the buffer storage magazine is divided into areas for normal-sized and over-sized or non-standard tools.

Exchange of tools between the buffer storage magazine and the machine tool magazine is performed by a handling device and is processed by the tool flow control facility. Loading and unloading in the buffer storage magazine is performed manually or by a handling device. When tools are loaded and unloaded they must be identified by entering their identification numbers.

### 19.9.11 SYSTEM VISUALIZATION

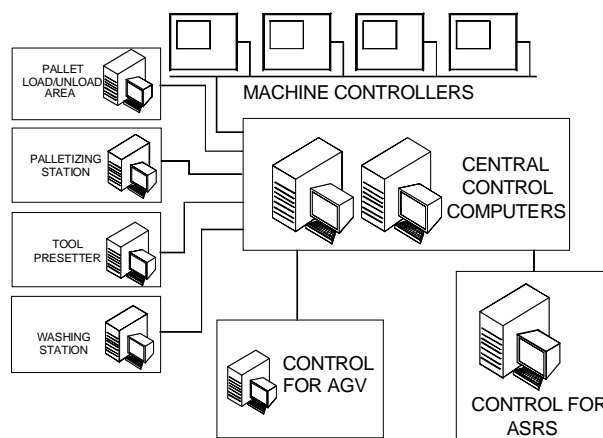
System visualization is a graphical representation of the layout of the FMC and workpiece carrier locations and displays the current status of the individual stations such as machine tools, transport vehicles, clamping stations and location of workpiece carrier. It also indicates the operating mode of the system.

### 19.9.12 SYSTEM CONFIGURATION

Several flexible manufacturing cells can be combined to form a system under the control of a supervisory computer.

In such a system, tasks are distributed among the individual cell computers and the supervisory computer. A typical arrangement is shown in Fig. 19.16.

Machine related functions such as CNC program supply and the machine tool programs, any material flow control within the cell and the associated data storage facilities remain at cell level.



**Fig. 19.16 System Configuration**

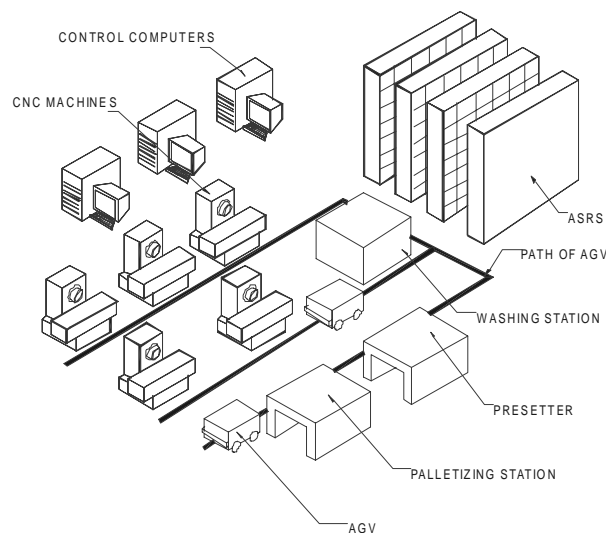
Execution of the higher functions of job scheduling, tool requirement management, material flow control and palletizing etc., are the responsibility of the co-ordination computer.

- Each of the cells is a self-contained functional unit
- The cells can be put into operation at different times
- The cells have a standardized interface to the supervisory computer
- The cells can be supplied by different machine manufacturers
- Incorporation of autonomous cells into the system can be done as and when needed.

### 19.10 TYPICAL FMS LAYOUT

Figure 19.17 shows the layout of a typical FMS. For the sake of clarity only a few representative component units are shown in the figure. The following major subsystems and components can be seen in the illustration:

- Automatic storage and retrieval system
- CNC machines
- Workpiece carriers (AGV's)
- Palletizing station
- Washing station
- Tool presetting station
- Computer control system



**Fig. 19.17 A Typical FMS**

The automatic guided vehicle takes the palletized workpieces from the palletizing station to the work centre. The guidance of the AGV is carried out through cables laid on the shop floor. The transfer of the palletized work from the AGV is effected through a special pallet changer device located in front of each of the machine tool.

### 19.11 FMS DEVELOPMENT IN INDIA

Because of the high cost in FMS, Indian manufacturers have not evinced much interest in the total adoption of this technology. The first unit of this type was established at the Heavy Alloy Penetrator Project (HAPP) at Trichy in South India during late 80's. This unit has all the facilities of a FMS. Part of the equipment was manufactured at HMT and the installation of the factory was done by erstwhile HMT CIM division. Subsequently a number of flexible turning cells have been set up by manufacturing industries in different parts of the country. FMS as a whole is not very popular today because of its high cost and the time taken to design and install one. However, the principles of FMS are quite relevant and are being widely followed for achieving global competitiveness.

#### QUESTIONS

1. Discuss the need for flexibility in manufacturing in the present manufacturing scenario.
2. Compare FMS with transfer lines and CNC on the basis of volume and variety of parts produced.
3. What is a FMC? How does FMC ensure flexibility in manufacturing?
4. How does a turning centre differ from an FMC?
5. Describe the essential elements of a flexible turning cell.
6. Describe the additional subsystems that make a machining centre a flexible machining system.
7. What are the various innovations introduced in tooling for flexible manufacturing systems?
8. How is tool life monitored in FMS?
9. Discuss the importance of in-process monitoring of workpiece quality in FMS.
10. What are the benefits of FMS?
11. Discuss the relevance of FMS from the point of view of work centre utilization.
12. Describe the principle of an automated storage and retrieval system.
13. What are the major elements of FMS?
14. Discuss the importance of materials handling system in FMS.
15. Describe the types of materials handling devices used in a FMS.
16. How is an FMS optimized?
17. What are the different types of data associated with FMS?



18. How are jobs scheduled in FMS?
19. Discuss the importance of palletizing.
20. How is NC program management effected in a FMS?
21. Discuss how the jobs are scheduled in a FMS.
22. Sketch the layout of a typical FMS and explain the important subsystems.
23. Compare the merits and demerits of a RGV and an AGV.
24. Discuss tool management in relation to the operation of a FMS.

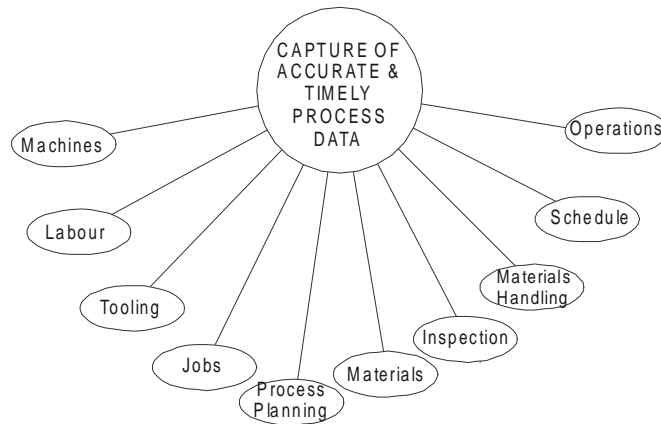
# SHOP FLOOR DATA COLLECTION SYSTEMS

*Shop floor data collection systems play an important role in getting the feedback about the execution of work on the shop floor. Whenever and wherever there is an action, some form of data is involved in that. Data collection equipment can be taken to that place and is used to collect the data. These places of action can be a production line, a quality control station, a maintenance location or even an unattached operation such as warehouse conveyor system. This chapter deals with the techniques used to collect shop floor data.*

## 20.1 INTRODUCTION

Monitoring the progress of the jobs is an integrated part of CIM. Collection of machine data statistics, estimation of the non-production times and machine utilization, tracking of flow of materials, determination of job completion times and realization of schedules, etc., are necessary to evaluate the efficiency of the functioning of the system. This requires automatic or direct data collection from the shop floor. The techniques and technologies by which the status of production is collected are called shop floor data collection. Fig. 20.1 illustrates various types of information/data to be collected from the shop floor. These include:

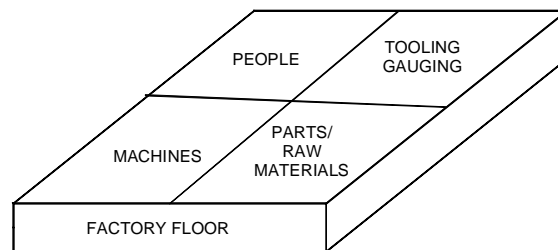
- (i) Machine data
- (ii) Operator data
- (iii) Tooling data
- (iv) Data relating to jobs to be done
- (v) Materials data
- (vi) Materials handling data
- (vii) Scheduling data
- (viii) Process planning data
- (ix) Inspection data



**Fig. 20.1 Components of Shop Floor Information System**

Material processing is a typical example of data collection. The various process planning methods described in Chapter 9 are used to plan the execution of the work before the actual manufacturing commences. It is necessary to monitor the process of the work to make sure that the work is performed as planned. This necessitates collection of shop floor data which includes machine data, actual completion time, and movement of the materials and the utilization of other resources.

There are several variables affecting the manufacturing productivity. These are shown in Fig. 20.2. Monitoring of shop floor data helps to identify factors which adversely affect productivity.



**Fig. 20.2 Variables Affecting Manufacturing Productivity**

## SHOP DATA REQUIREMENTS

### PEOPLE - AVAILABILITY

- a: Workstations
- b: Idle
- c: Absent

### MACHINES - STATUS

- a: Idle
- b: Setup

- c: Production
- d: Delay
- e: Downtime

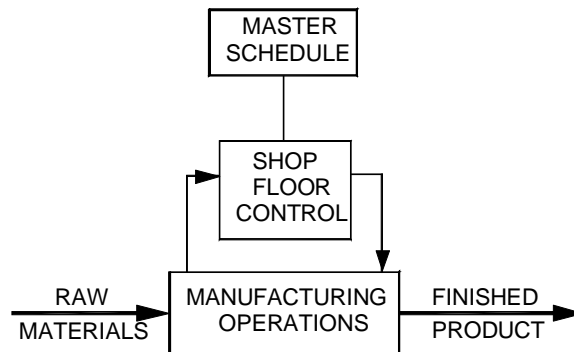
#### PARTS/RAW MATERIALS LOCATION

- a: Raw Stores
- b: Transit
- c: On-machine
- d: Waiting
- e: Finished stores
- f: Assembly
- g: Missing

## 20.2 SHOP FLOOR CONTROL

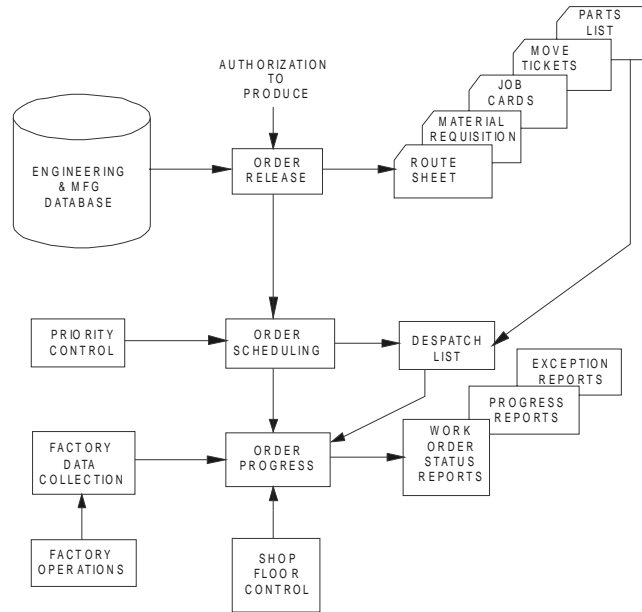
Shop floor control deals with managing the work-in-process. This consists of the release of production orders to the factory, controlling the progress of the orders through the various work stations, and getting the current information of the status of the orders.

This can be shown in the form of a factory information system. (Fig. 20.3). The input to the shop floor control system is the collection of production plans. These can be in the form of master schedule, manufacturing capacity planning and ERP data. The factory production operations are the processes to be controlled.



**Fig. 20.3 Factory Information System**

A typical shop floor control system consists of three phases. In a computer integrated manufacturing system these phases are managed by computer software. These three phases connected with the production management is shown in Fig. 20.4. In today's implementation of shop floor control, these are executed by a combination of computers and human resources. The following sections describe the important activities connected with this task.



**Fig. 20.4 Phases in Shop Floor Control**

### 20.2.1 ORDER RELEASE

The order release in shop floor control provides the documentation needed to process a production order. The documents in the shop floor order may consist of the following documents

- (i) Route Sheet
- (ii) Material requisition to draw necessary materials from the stores
- (iii) Job cards or other means to report direct labour time given to the order.
- (iv) Instructions to material handling personnel to transport parts between the work centres in the factory
- (v) Parts list for assembly, in the case of assembly operations.

In a typical factory which works on manual processing of data these documents move with the production order and are used to track the progress through the shop. In a CIM factory, more automated methods are used to track the progress of the production orders.

The order release is connected with two inputs. Authorization proceeds through the various planning functions (MRP, capacity planning). These provide timing and scheduling information. The engineering and manufacturing database provides the product structure and process planning information needed to prepare the various documents that accompany the order through the shop.

### 20.2.2 ORDER SCHEDULING

This module assigns the production orders to various work centres, machine tools, welding stations, moulding machines etc., in the plant. It follows directly from the order release module. Order scheduling executes the dispatch function in production planning and control. The order scheduling module prepares a dispatch list that indicates which production order should be accomplished at the various work centres. It provides the information on the relative priorities of the various jobs by showing the due dates for each job. By following the dispatch list in making work assignments and allocating resources to different jobs the master schedule can be best achieved.

The order schedule module addresses to two important activities in shop floor production control.

- (i) Machine loading
- (ii) Job sequencing.

Allocating the orders to the work centres is termed as machine loading or shop loading, which refers to the loading of all machines in the plant. In most cases each work centre will have a queue of orders waiting to be processed. This queue problem can be solved by job sequencing. This involves determining the order in which the jobs will be processed through a given work centre. To determine this sequence, priorities are given to jobs in the queue and the jobs are processed according to the priorities. Several queuing models are available in operations management to solve this problem.

This control of priorities is an important input to the order scheduling module. Rules to establish the priorities are:

- (i) Earliest due date: These are given high priority
- (ii) Shortest processing time: Shorter processing time orders are given high priority.
- (iii) Least slack time: Orders with least slack time are given high priority.

Fluctuations in market demand, equipment breakdown, cancellation of the order by customer and defective raw material or delay in the receipt of materials affect the priority. The priority control plan reviews the relative priorities of the orders and adjusts the dispatch list accordingly.

### 20.2.3 Order Progress

The order progress module in the shop floor control system monitors the status of the various orders in the plant work-in-process and other characteristics that indicate the progress and performance of production. The function of the order progress module is to provide the information that is useful in managing the factory based on the data collected from the factory. The order progress report includes:

- (i) **Work order status reports:** These reports indicate the status of the production orders. Typical information in the report includes the current work centre where each order is located, processing hours remaining before completion of each order, whether the job is on-time or behind schedule, and priority level.

- (ii) **Progress report:** A progress report records the performance of the shop during the period of master schedule and reports the number of operations completed and not completed during the time period.
- (iii) **Exception reports:** These reports bring out the deviations from the production schedule (ex. overdue jobs).

The above reports are useful to production management in making the decisions about allocation of resources, authorization of the overtime hours, and other capacity issues, and in identifying areas of problems in the plant that adversely affect the implementation of the master production schedule.

### 20.3 SHOP FLOOR DATA COLLECTION

There are several of data collection techniques to gather data from the shop floor. Some of the data are keyed by the employees and the rest are recorded automatically. Later the data is compiled on a fully automated system that requires no human intervention. These methods are collectively called as shop floor data collection systems.

These data collection systems consist of various paper documents, terminals and automated devices located through the plant in a plant. The shop floor data collection system serves as an input to the order progress module in shop floor (Fig.20.4).

Examples of the data collection in shop floor are:

- (i) To supply data to the order progress module in the shop floor control system.
- (ii) To provide up to date information to the production supervisors and production control personnel.
- (iii) To enable the management to monitor implementation of master schedule.

To carry out this, the factory data collection system inputs the data to the computer system in the plant.

### 20.4 TYPES OF DATA COLLECTION SYSTEMS

The shop floor data collection systems can be classified into two groups.

- (i) On-line data collection systems
- (ii) Off-line data collection systems

#### 20.4.1. ON-LINE DATA COLLECTION SYSTEMS

In an on-line system, the data are directly entered to the computer and are available to the order progress module. The advantage lies in the fact that the data file representing the status of the shop is always at the current state. As and when the changes in the order progress module are reported they can be fed to computer and in turn to the status file. In this way the production personnel are provided with most up-to-data information.

### 20.4.2 OFF-LINE (BATCH) DATA COLLECTION SYSTEMS

In this the data are collected temporarily in a storage device or a stand alone computer system to be entered and processed by plant computer in a batch mode. In this mode there is delay in the entry and processing of the data. The delay may vary depending upon the situation. So this system cannot provide real time information of shop floor status. The advantage of this system is that it is easier to install and implement.

## 20.5 DATA INPUT TECHNIQUES

As stated earlier, the data collection techniques include manual procedures and computer terminals located on the shop floor. The manual data collection methods require the production workers to fill out paper forms indicating order progress data. These forms are compiled using a combination of clerical and computerized methods.

The manual data collection methods rely on the co-operation and clerical accuracy of the employees to record a data property on a proper document. Errors may creep in this type of method. The common forms of errors that can be checked and rectified are wrong dates, incorrect order numbers and incorrect operation numbers. These can be detected and corrected. There are, however, other errors which are difficult to identify.

Another problem is that there may be a delay in submitting the order progress for compiling. The reason is that there will be always a time lapse between when occurrence of events and recording of events.

These problems necessitate the location of the data collection equipment in the factory itself. The various input techniques include manual input by push-button pads or keyboards. Error checking routines can be incorporated to detect the syntax errors in the input. The data entry methods also include more automated technologies, such as bar code reader, magnetic card readers etc.

An important type of equipment used in shop floor data entry is keyboard based systems. There are various types of such systems. They are discussed in the following sections.

### 20.5.1 CENTRALIZED TERMINAL

A single terminal is located centrally in the shop floor. This requires the employees to go to the terminal and input the data. So employee's time will be wasted and in a big shop, this becomes inconvenient.

### 20.5.2 SATELLITE TERMINALS

These are multiple data collection centres located throughout the shop floor. In this arrangement a balance is to be struck between the minimization of the investment cost and maximization of the convenience of the employees in the plant.



### 20.5.3 WORK CENTRE TERMINALS

The most convenient arrangements to the employees are to have a data collection terminal at each work centre. This reduces the time to go to the central terminal. This can be applied when the amount of data to be collected is very large.

## 20.6 AUTOMATIC DATA COLLECTION SYSTEM

The recent trend in industry towards use of more automation necessitates putting in place automated data collection methods. Although the term automatic is used here, human participation is unavoidable in many cases.

The advantages of the automatic data collection methods are:

- (i) The accuracy of data collected increases
- (ii) The time required by the workers to make the data entry can be reduced.

The basic elements in data collection systems are:

- (i) Machine readable media
- (ii) Terminal configuration
- (iii) Software for data collection.

### 20.6.1 MACHINE READABLE MEDIA

Typical machine readable media include:

- (i) Bar Code Technology
- (ii) Optical Character Recognition (OCR)
- (iii) Magnetic Ink Character
- (iv) Voice Recognition (VR)
- (v) Magnetic Strip Technology
- (vi) Smart Cards

## 20.7 BAR CODE TECHNOLOGY

Bar code technology is primarily an automatic identification technique. The data is simply reduced to a printed form, which consists of a symbol made of successive line segments. A bar code reader is used to illuminate the bar code symbol and examine successive segments of the symbol. The detected area may be a highly reflected area (space) or a non-reflective (bar). As the reader moves over the bar code symbol, due to reflectivity and non-reflectivity, alternate transitions from light to dark and dark to light occur. These are detected and the time it will take will be converted to digital representations of ones and zeros of the bar code messages. Most commonly used bar codes are:

- (i) Universal Product Code (UPC)
- (ii) Interleaved 2 of 5 (ITF)
- (iii) Code 39

There are two types of bar code readers. They are classified as:

- (i) Fixed Beam Reader
- (ii) Moving Beam Reader

### 20.7.1 FIXED BEAM READER

Bar code readers are either fixture mounted or hand held. The simplest form of bar code reader is a light pen. The tip of the light pen is moved in contact with the symbol and moves the tip from leading zone through trailing zone in a smooth sweeping motion. The fixed beam light pen nearly or actually touches the symbol.

In fixture mounted reader the beam reader is fixed and the symbol moves. The reader is mounted on a conveyor or a transport system, observing a symbol while it passes through a reader beam. The fixed beam reader reads the symbol only once. In hand-held fixed beam reader the symbol can be rescanned easily. In the fixture mounted bar code reader some mechanism which moves the symbol towards the symbol is necessary i.e., an intervention by operator is needed.

In fixed beam reader the contact with the symbol may erase the symbol and so it is less readable in subsequent attempts to read the symbol. Contact scanning of the symbol requires a smooth surface. So it is not suitable to read all the surfaces on which the symbols are printed.

Light pens interpret a narrow section of the symbol printed on a surface. This may cause the distortion of the image. Fixed beam reader takes more time to read the symbol. Speed of fixed beam readers is a function of conveyor speed and height of the bar code symbol. Faster scanners are required for shorter symbols and slower scanners are required for larger symbols.

### 20.7.2 MOVING BEAM READER

These minimize limitations of the fixed beam reader i.e., intervention problem and contact with the symbol. Moving beam reader, as the name indicates, scans the symbol by a line of light emitted from the reader. This is actually a spot which moves at faster rates appearing as a straight line. A moving beam reader takes less time to scan the symbol depending on the type of equipment.

The light emitted from the moving beam reader can be drawn through the symbol in both the configurations i.e., hand held and conveyor configurations. Multiple viewing of the symbol provides quick and correct information to convert the image to computer data.

### 20.7.3 ELEMENTS OF BAR CODE READERS

The hardware of a bar code reader consists of a detector and a light source.

- (i) All fixed, moving beam readers will have a single detector which samples very small areas of the symbol. The detector used is linear charge coupled device. These employ a line of detectors which takes a snap shot of the symbol and projects the image on photo sensitive device. Then the detector is amplified to know whether it has observed a space or a bar. This is applied for a bar code of maximum length of 5 cm or less. This cannot be used for larger bar codes.

A matrix charge coupled device has a matrix of detectors (64 pixels long and 64 pixels high). These can be used either hand held or moving configurations or eliminates the problems associated with the voids, spots and edge roughness of the code. These can be used to detect long narrow bars as well as wide bars.

- (ii) The light source employed in a bar code reader to illuminate the symbol may be a red light or infrared light.

Red light is obtained from Helium-Neon lamp transmitting at 633 nanometres. The problem associated with this is that red and white colors appear to be same for the detector. Infrared light source operates at 900 nm and is invisible to the human eye but can be detected by the photo detector. Limitations of this type are the ink used to print bar code should have high carbon content.

A light source which operates at 800 nm or nearly infra red range will be able to read dye and colour based inks having high carbon content.

The cost of bar code system depends on the manufacturing facility. If the same manufacturing organization is printing and reading the symbol, the cost may be less.

## 20.8 OPTICAL CHARACTER RECOGNITION

The optical character recognition (OCR) employs special fonts which can be read by man and machine. This is more reliable than key entry but less reliable compared to bar code technology.

OCR fonts or characters are 'read' by software template techniques or feature extraction or combination of both. So each character is to be unique compared to other characters in the set.

When a number of pages of data are to be input to a computer system, optical page readers are very useful. Optical page readers are similar to the office copiers. In OCR, entire page is to be scanned before next page is presented to the reader. The characters in a page are identified by the reader by the specific font styles and sizes.

In OCR, the reading device is to be passed over the OCR character a number of times. Here, the reader must be precisely positioned over the string which is to be read. The poses a problem when long strings of information are to be read. OCR is very sensitive to the motion of the operator's hand during reading. OCR can not read the symbols on the moving objects. To read the information on the moving objects a strobe light is to be synchronized with object.

OCR techniques identify the horizontal and vertical strokes, curves and endings peculiar to each character. The absence of vertical redundancy and repeating character pattern causes OCR to be prone to errors. These are caused by poor print quality and those introduced through scanning process.

## 20.9 MAGNETIC INK CHARACTER RECOGNITION

Magnetic Ink Character Recognition (MICR) uses stylized OCR fonts. The fonts are printed with a magnetic ink to permit readability after being overprinted or even smudged. MICR is used to read smaller documents of size 7 to 20 cm. Like OCR, these also require precise orientation and registration.

## 20.10 VOICE RECOGNITION

Speech is the most natural way of communication. This eliminates the need of the user to understand a computer system. Voice technology is intelligently packaged and applied in several applications. Moreover the training can be minimized and the key board entry can be eliminated and hand and eye co-ordination is no longer needed.

Voice recognition (VR) is of two types:

- (i) Speaker dependent
- (ii) Speaker independent

Most voice recognition systems are speaker independent systems. VR systems recognize the user's vocabulary and store a computer image of each utterance and compare later the input words to the computer stored words. If the input matches the stored pattern, recognition is achieved. This provides larger vocabulary and accurate recognition. Commercial VR systems are having around a few hundred words in active vocabulary and skilful programming can develop application dependent vocabularies.

Real application of VR systems rests on the fact that user need not be trained to use the system. Speaker independent system uses recognition template from memories of the previously recorded images. The templates represent speech patterns of both male and female speakers. These are now available with limited vocabularies.

## 20.11 SMART CARDS

Smart cards are made of plastic. They are of the size of a credit card and are embedded with one or more microchips. These have an 8-bit or higher level microprocessors and will have a storage capacity of about 8 kB. Recent cards can carry up to 256 kB with the contacts removed and integrated with keypads. Personal identification numbers (PIN) prevent unauthorized use of smart cards.

## 20.12 DATA ACQUISITION SYSTEMS (DAS)

The trend in shop floor data collection is towards the more use of the automated systems. Some of the bar code reading methods and other automatic identification methods discussed earlier can be operated in a fully automated mode.

Computer process monitoring system involves a computer which is directly connected with the manufacturing process for the purpose of collecting the data on the process and the equipment.

The hardware components of the computer process monitoring system used to input the data from the process are sensors and transducers, analog-to-digital converters, limit switches and photo detectors, pulse generators etc.

A data acquisition system is a computer system used to collect the data from a process or piece of equipment. These perform an analysis of data or transmit the data to another computer for processing and analysis. A microprocessor is used as the controller/processor in a DAS. Other controllers use minicomputers or single board computers. The function of the controller/processor is to synchronize the data sampling and storage and tabulate data for presentation and statistical and other analysis.

Components of DAS include analog transducers, Analog-to-digital converters, digital transducers, and digital input interfaces.

Separate data acquisition modules are often attached with FMS elements to enable operation to send status information to the control computer.

### QUESTIONS

1. Discuss the need and importance of shop floor data collection systems. What are their functions?
2. What are the major types of data collection systems?
3. What are the devices used for shop floor data collection?
4. How does a bar code reader work?

# SIMULATION IN MANUFACTURING

*The need to reduce time to market requires that costly iterations in product development should be avoided. This means that the manufacturing engineers have to do every job right first time every time. Manufacturing simulation is one way of ensuring that the process is modeled and tested before the manufacture commences. Some details of this technology are discussed in this chapter.*

## 21.1 INTRODUCTION

Simulation in manufacturing refers to a broad collection of computer based applications to imitate the behavior of manufacturing systems. A system is a facility or a process either actual or planned such as factory with workers, machine tools, materials handling devices, storage devices etc. Simulation is intended to study the model of this real world system by numerical evaluation using software. Simulation is carried out to evaluate the performance of a system, product or process before it is physically built or implemented. Simulation was discussed in this book earlier in different contexts- design simulation using finite element technique, manufacturing process simulation also using finite element technique, simulation of robots and simulation of CNC machines. Another type of simulation, which has become very popular of late, is manufacturing or factory simulation. Factory simulation involves creating a virtual factory. Here, instead of simulating a process or a work centre the entire factory is simulated to have a clear understanding of the working of the plant as a whole.

Simulation technology holds tremendous promise for reducing costs, improving quality, and shortening the time-to-market for manufactured goods. In the present context, simulation refers to the study of the performance of a manufacturing system or a factory. Simulation involves modeling and visualization of the entire plant. There are several potential benefits from simulation. But lack of understanding, cost of software and expertise have made simulation not popular with manufacturing engineers, till recently.

The development and maintenance of simulation models of manufacturing equipment can be costly. For example, let us take the case of a machine shop. A detailed simulation

model of a single machine tool may take an engineer several weeks to create, and such customized models are required for each type of machine tool. However, standard reusable simulation model codes are now available which reduces the time involved in creating the model.

Today, computer-based simulation is inexpensive and effective. Simulation makes it easier to evaluate production cells or systems before implementing them. It allows errors or deficiencies to be identified and corrected before they are implemented. Models can be built, tested and compared for different design variations. 'What-if' analysis can then be carried out either to choose the best design or layout or product mix. Extensive simulation studies can be carried out to evaluate the performance of a manufacturing system, under various input and operating conditions as well as under different plant configurations and capacities.

Simulation helps to meet the objective of bringing products to the market faster because it does not require the time-consuming activities of building physical models of the plant. Instead it uses the models designed in the computer, which would normally be the basis for building the physical models. Building physical models of plants is not practical and even if made, they are not suitable for simulation purposes. Thus, time is saved because it is not necessary to build the 'physical' model. In addition, even more time is saved as modifications could be made to the computer-based model to improve the performance of the plant and the simulation is repeated as a "what if" case.

In addition to usual applications like system design and performance estimation, simulation can also be used for scheduling. The simulation software in this case gathers the required data from manufacturing execution system and generates multiple schedules from which optimum could be selected.

## 21.2 TYPES OF SIMULATION

Simulation could be classified into three types.

- i. **Static or dynamic simulation:** In static simulation time does not have a role. However, most of the manufacturing systems are time dependent and are hence dynamic.
- ii. **Continuous or discrete:** A continuous system is one which continuously varies with time. Examples are refinery, thermal power plant and plate glass manufacturing plant where production is continuous but may fluctuate over time. An automotive assembly plant is more or less a continuous system. On the other hand, a company manufacturing machine tools, motors, pumps, is a discrete system. A Job shop where batch quantity may vary from one to many is another example of a discrete manufacturing plant. In some cases, the manufacturing system may be a combination of both discrete and continuous system. Such a system may be called mixed continuous-discrete system. Discrete event simulation is a powerful tool in manufacturing. The advantage of the simulation model is

that it can be reused for a different problem or to evaluate another option. In the globalization era, engineers should be capable of responding faster to dynamically changing global markets and simulation helps to reduce the time to market.

- iii. **Deterministic or stochastic:** Systems which have no random inputs are deterministic. A design bureau or a rapid prototyping shop may receive orders at random. Several fabrication companies may also fall under this category. A manufacturing system may also have both deterministic and random inputs.

### 21.3 TECHNIQUES OF SIMULATION

Simulation can be carried out in three ways.

- i. Programming in general purpose simulation languages
- ii. Simulation using simulation languages
- iii. High level simulators

These are briefly explained in the subsequent sections.

#### 21.3.1 SIMULATION USING GENERAL PURPOSE LANGUAGES

Simulation programs can be written in high level languages like FORTRAN or C. This approach was popular when simulation languages were not available. The advantage of this approach is the opportunity to design the system to a specific application in a customized manner. However, the process is tedious, time consuming and error prone.

#### 21.3.2 SIMULATION LANGUAGES

General Purpose Simulation System (GPSS) is one language popularly used for simulation. GPSS is a family of mostly-declarative languages designed for discrete-event simulation and system modeling. A GPSS simulation program consists of a set of blocks which include generators, queues, servers, selectors or routers, data collectors, timing and computational nodes. Data types supported in simulation models vary between versions, but usually include integers, real numbers, strings, and records. GPSS systems always had sophisticated random sample generators to model various probability distributions that to model real-world processes. SIMSCRIPT, SLAM, SIMAN etc were later developed and became popular with manufacturing industry. These are very flexible to simulate variety of systems.

#### 21.3.3 HIGH-LEVEL SIMULATORS

High level simulators differ from the simulation languages as the latter feature in addition powerful graphics user interfaces, menus and dialog boxes. Standard constructs enable the user to model a system quickly. This makes model creation faster. However, there is a trade off in flexibility. The facility for dynamic graphic animation gives the user to visualize the actual working of the system.



## 21.4 SIMULATION PROCESS FOR MANUFACTURING SYSTEMS ANALYSIS

The process of simulating a manufacturing system involves the following steps.

- i. **Model design:** In this step the issues to be addressed are identified based on which the project is planned. Next step is to develop a conceptual model.
- ii. **Model development:** The simulation engineer chooses a modeling approach suitable for the problem. After building the model it is tested to verify and validate the model.
- iii. **Model deployment:** The model is used to carry out experiments like 'What if' analysis. The results are then studied and used for making decisions.

## 21.5 SIMULATION SOFTWARE PACKAGES

There are a number of simulation packages in use today. Some of them are listed below:

- Analytica
- Arena
- Automod
- Autoshed
- @risk
- Crystal Ball
- eM Plant
- Enterprise Dynamic Simulation Software
- Enterprise Dynamic Simulation studio
- Extend OR
- Extend Suite
- FlexSim
- GPSS
- GoldSim
- Lean\_modeler
- MAST
- Process Simulator
- Pro Model
- PSM+++
- SAIL
- Show Flow 2
- SIGMA
- SIMAN

- SIMPROCESS
- SIMSCRIPT II.5
- SIMUL8
- SLIM
- Supply chain Guru
- Visual Simulation Environment
- Web GPSS
- Witness 2006
- XLSim

Standardized interfaces, component model libraries, and modeling techniques have reduced the cost and increased the accuracy and accessibility of manufacturing simulation technology. Simulation is commonly used manufacturing system design and improvement methods such as lean manufacturing and six sigma.

## 21.6 APPLICATION OF SIMULATION

Simulation has been widely used in the manufacturing industry to optimize the design of the shop floors and tailor the facility to yield the required output. It is also used to predict the output under various input and operating conditions. Automotive industry and aerospace industry are the major industries, which make use of simulation. The following sections give brief details of how simulation is used in industries.

### 21.6.1 SIMULATION IN AUTOMOTIVE INDUSTRY

The automotive industry uses discrete event simulation to investigate the capabilities of the different manufacturing shops involved in building automobiles like body shops, paint shops, trim/chassis/final assembly shops, and engine assembly shops, machining shops and stamping shops.

Simulation of body shop systems during the concept, design and build phases of a product life cycle allows an automotive company to investigate the impact of tooling, conveyor and material delivery systems on the throughput.

There are two different approaches adopted to analyze the performance of a body shop. The first is to model the body shop at the station level. The second approach is to model the body shop at the line or subassembly level of detail.

The station-level simulation model is used to analyze the stand alone capability of a subassembly area. Station cycle times and downtimes are entered into a simulation model and the subassembly throughput is estimated. The subassembly throughput can be compared directly to the body shop target throughput. As a general rule, the subassembly throughput must be greater than the full body shop throughput or new design of the subassembly area would be needed. If complex manual operations occur at a station, these

operations can be added to the station level model. Modeling the walk, pickup and set down times can identify if an individual station can meet the required cycle time for the subassembly area.

While the station-level analysis of the subassembly areas is being carried out, a line level model can be developed. The throughput estimates from the individual subassembly models are entered into the line level model and the conveyor systems are modeled in detail. The interaction between the subassemblies and the conveyor systems can be used to identify sets of subassemblies or individual subassemblies to identify the bottlenecks in the body shop. Sizing of the conveyor can be accomplished by increasing buffer between bottleneck subassembly areas and reducing buffer between non-bottleneck areas. This process continues through the design phase.

An alternative to this approach is to integrate all of the subassembly models into one large detailed model. Any time a subassembly changes or the conveyor layout changes, the model is updated to analyze the full body shop system.

The full body shop model is also used to investigate the impact that operational parameters have on the system once it is implemented. The operational parameters can include: preventative maintenance, reducing mean time to repair, batch sizing, and overtime. Changing operational parameters and identifying their impact on system performance will show the opportunities for increasing system performance and will aid in the prioritization of funding.

An additional analysis that occurs in the body shop is the delivery of materials to the line locations. This analysis investigates the impact of the number of fork lift trucks, fork lift truck assignments, the amount of stock at the line, the location of storage areas, the locations of docks, and the number of docks on delays caused by parts not present at the line. In the concept phase, this analysis can influence the location of subassemblies and identify strategic locations for stock to minimize the material delivery times.

When automotive paint shops are simulated, the focus is usually on the power-and-free conveyor systems that transport parts through the painting operations. Power-and-free systems are different from other conveyors because of carriers that fix themselves to the drive chain by means of a hooking mechanism called a dog. When two different speed chains merge, carriers can accumulate and are picked up by the dogs on the new chain. There are two types of chains: low speed production chains used while parts are being painted and high speed transport chains, which move parts between different production areas.

During the design phase of a paint system, the power-and-free layout is evaluated using simulation to determine if throughput targets can be met. Power-and-free systems may require kilometers of production and transport chain to connect different sub-systems to transport parts. Simulation is used to determine the number of carriers required, how chain merges and transfers will operate and whether adequate accumulation is provided. In some areas where higher density empty carrier storage is required, carriers are rotated

before accumulation, which is called bias banking. The size of bias bank buffers can be determined using simulation.

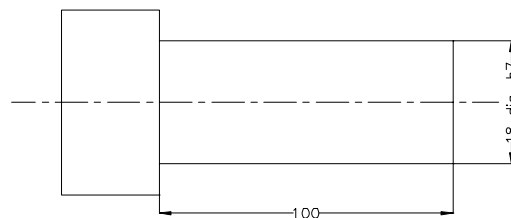
Simulation is used while operating a paint system to determine the effects of adding different body styles and paint types to existing lines. As new models with varied vehicle paint options are introduced, it becomes necessary to modify paint lines to handle new requirements. Simulation provides a test bed where changes in the paint shop to meet the new production requirement can be evaluated prior to making any changes to the existing system. This reduces not only the system downtime during changeover but also instills confidence in operators, supervisors and managers.

### 21.6.2 SIMULATION IN AIRCRAFT MANUFACTURING

Simulation is widely used in aircraft manufacturing. One of the projects where simulation has been reported to have been extensively used is Boeing's Dream liner project.

## 21.7 PROCEDURE FOR SIMULATION USING SOFTWARE

The following section describes a simple example of simulation using Arena. This is almost a trivial case but is adequate to introduce the reader to the process of simulation. The example taken is that of turning a pin of 16mm diameter in a centre lathe from a polished C45 rod of 25 mm diameter. Figure 21.1 shows the component. The batch size is 10 and the manual operation takes 10 minutes per piece. The finished part is inspected and those components which fall within the dimension limits are accepted. The rest are rejected.

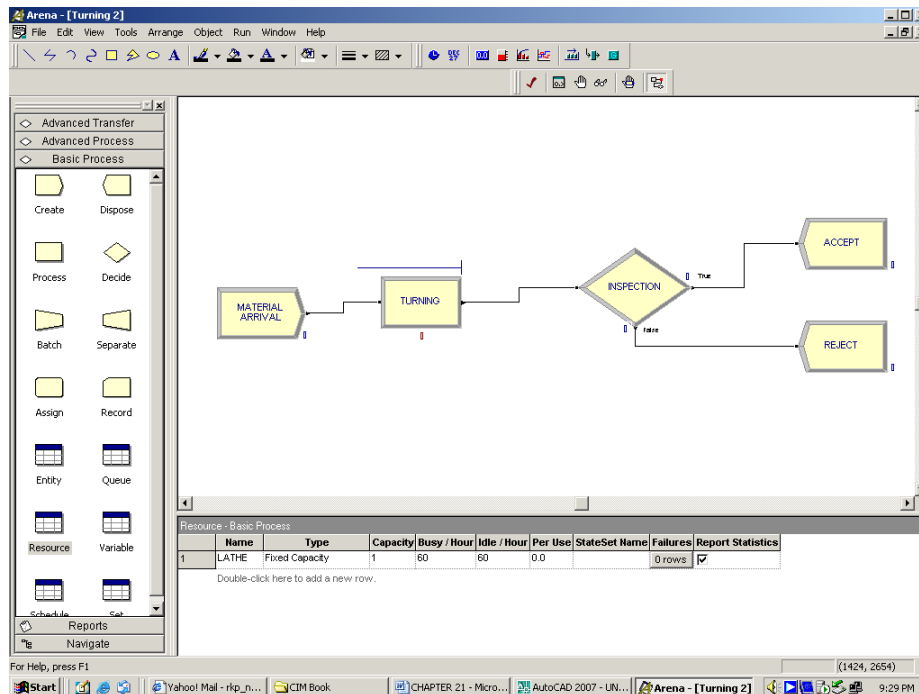


**Fig. 21.1 Component to be Machined**

The simulation is carried out in a systematic manner as explained in subsequent sections.

- (i) **Modeling the process:** During this stage the process is defined, documented and communicated.
- (ii) **Simulation:** The system is studied to understand its performance and explore possibilities of improvement.
- (iii) **Visualization:** With the aid of graphics animation, the process is visualized.
- (iv) **Analysis:** The performance of the system can be studied to predict the performance of the system under various "what if" conditions.

A simple process of simulating a machining operation is discussed in this section. To begin with let us look at how the machining operation is carried out. A flow chart as shown in Fig. 21.1 is built first.



**Fig. 21.2 Flow Chart**

Figure 21.3 shows a typical modeling environment. There are three areas demarcated.

The project bar will have a process panel, reports panel and navigate panel. There are two panels in the model window-the flow chart view and spreadsheet view. The former will contain the model graphics – flow chart, animation and other drawing elements. The latter displays model data such as operation times, costs and other parameters.

### 21.7.1 MAPPING THE PROCESS IN A FLOW CHART

- (i) Drag “create” module from the process panel to model window. This will be renamed as entry of work (indicating the arrival of materials, drawings, process sheet, tools etc.) (Fig. 21.4 (a))

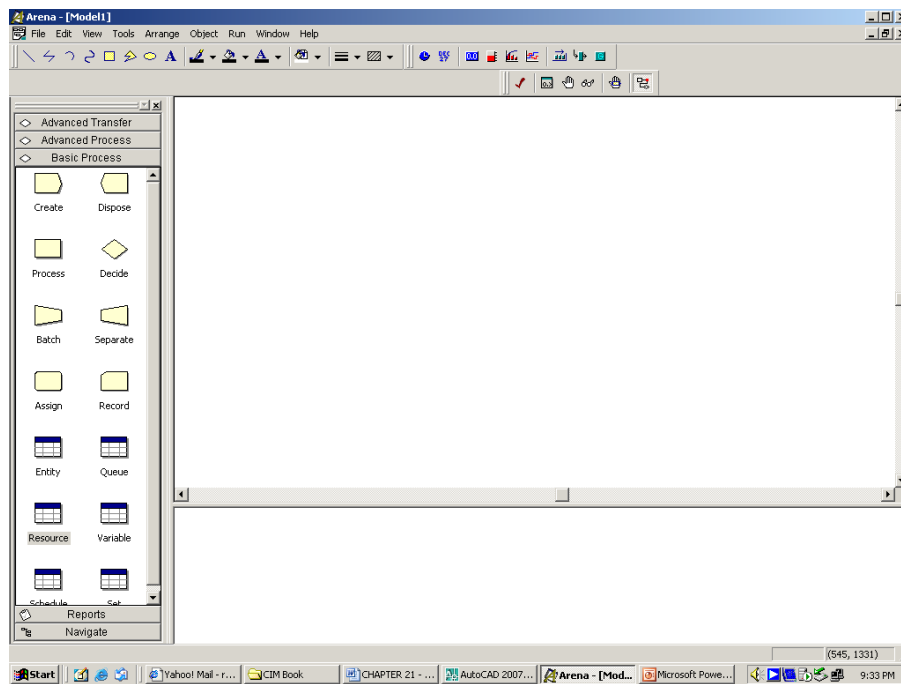


Fig. 21.3 Simulation Environment

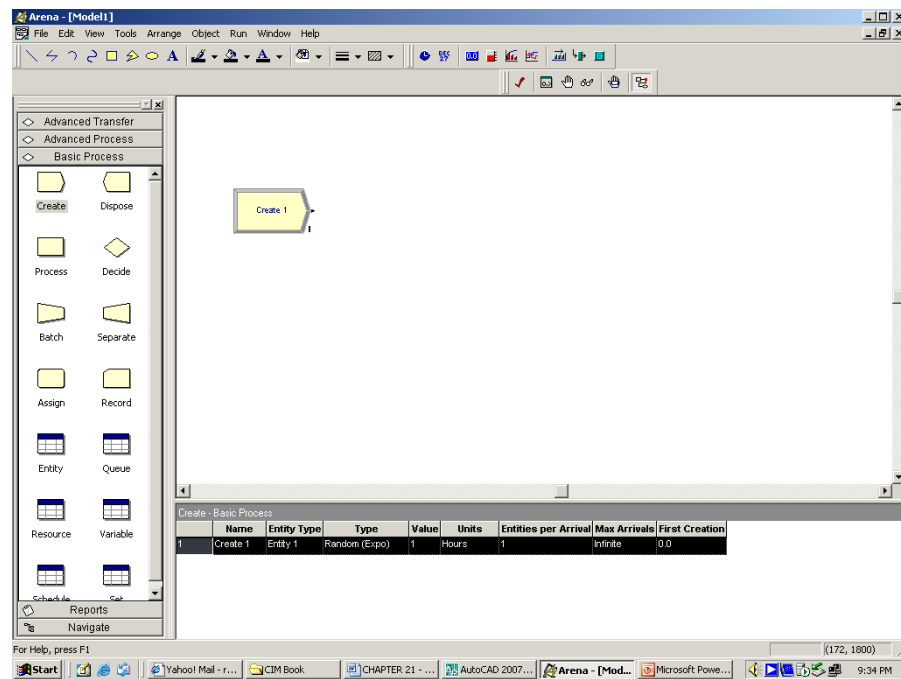
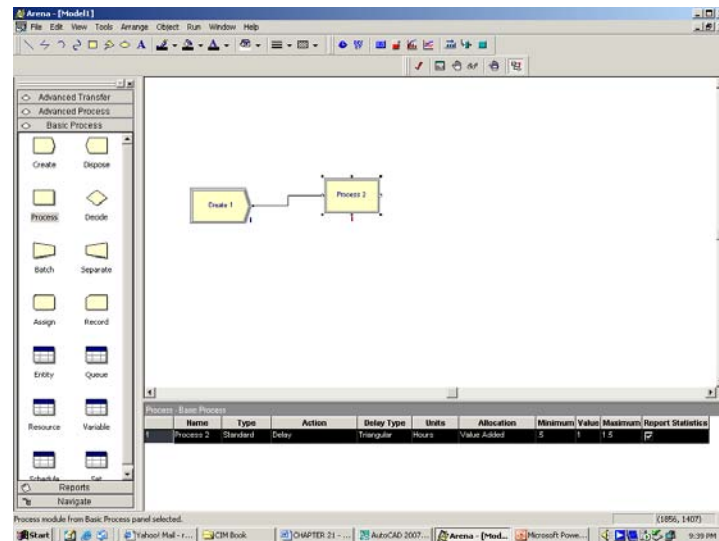


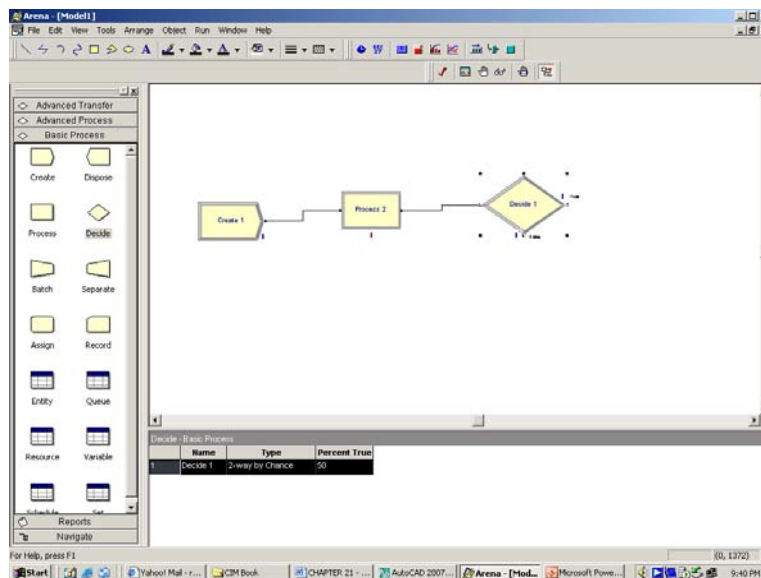
Fig. 21.4 (a) Inserting Create Module

- (i) Drag process module and place it next to the create module (Fig. 21.4 (b)). This represents the actual machining operation. The drawing indicates machining a pin to size  $18\phi$  h7 with a tolerance range of 18.00 and 17.979.



**Fig. 21.4 (b) Process Module**

- (ii) Drag a decide module to the right of process module (Fig. 21.5).



**Fig. 21.5 Adding Decide Module**

The machined components are inspected for acceptance or rejection. If the diameter is within 18.00 and 17.979, the work is accepted. If it is above or below the tolerance range, the work is rejected.

- (iii) Drag two dispose module to the right of decide module one for acceptance of good work pieces and one for the rejection of defective pieces.

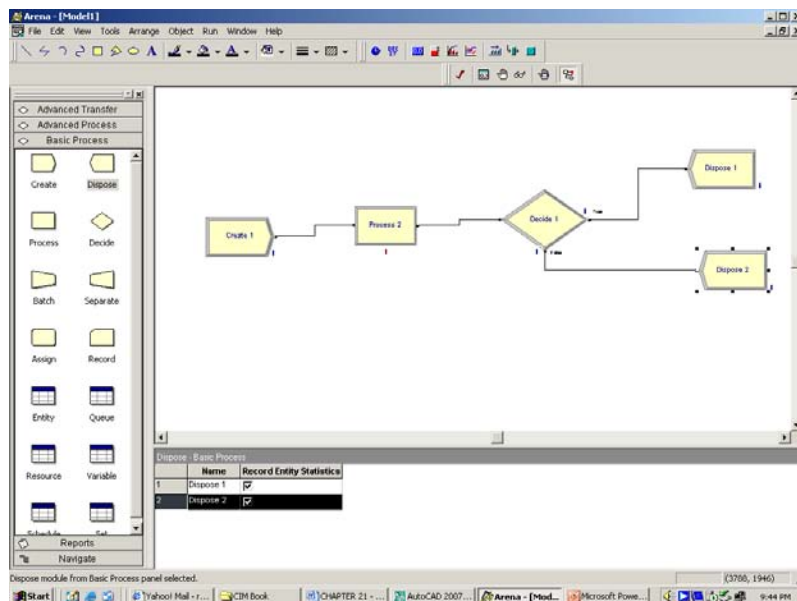
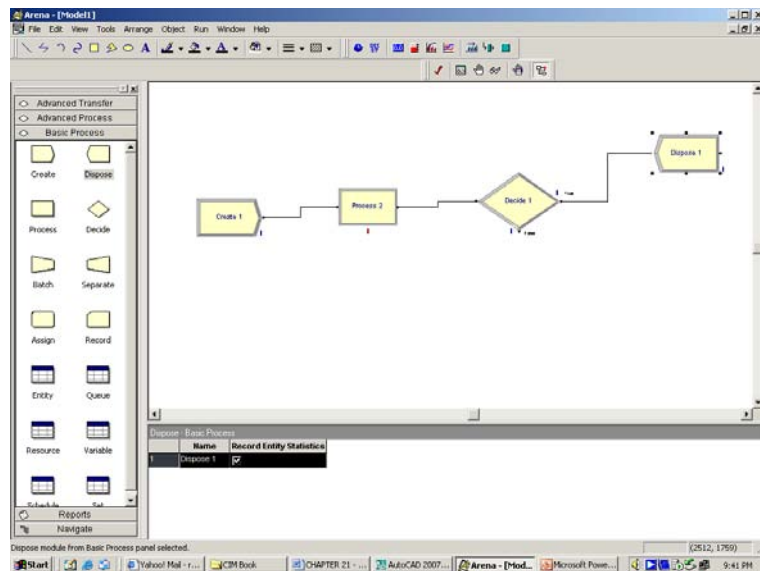


Fig. 21.6 (a) & 21.6 (b) Adding Dispose Module

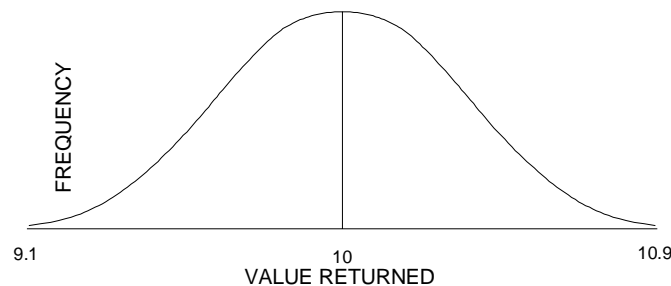


### 21.7.2 DEFINING MODEL DATA

- (i) Double click create module.
- (ii) In the name field type arrival of materials.
- (iii) For entity type, type materials.
- (iv) Type 240 in the value field for time between arrivals. Click OK to close the dialog box.

### 21.7.3 PROCESS MODULE

The machining operation can be assumed to follow Normal distribution



**Fig. 21.7 Time for Completion of a Job**

- Double click process module.
- In the name field type TURNING
- Select seize Delay Release for action
- Click add for resources
- In the resource dialog type lathe
- Click OK to close dialog box.

Define process parameters Mean – 10, Standard deviation 0.3 Fields.

Click OK to close dialog box.

### 21.7.4 DECIDE MODULE

In this module, we decide acceptance or rejection of the machined components.

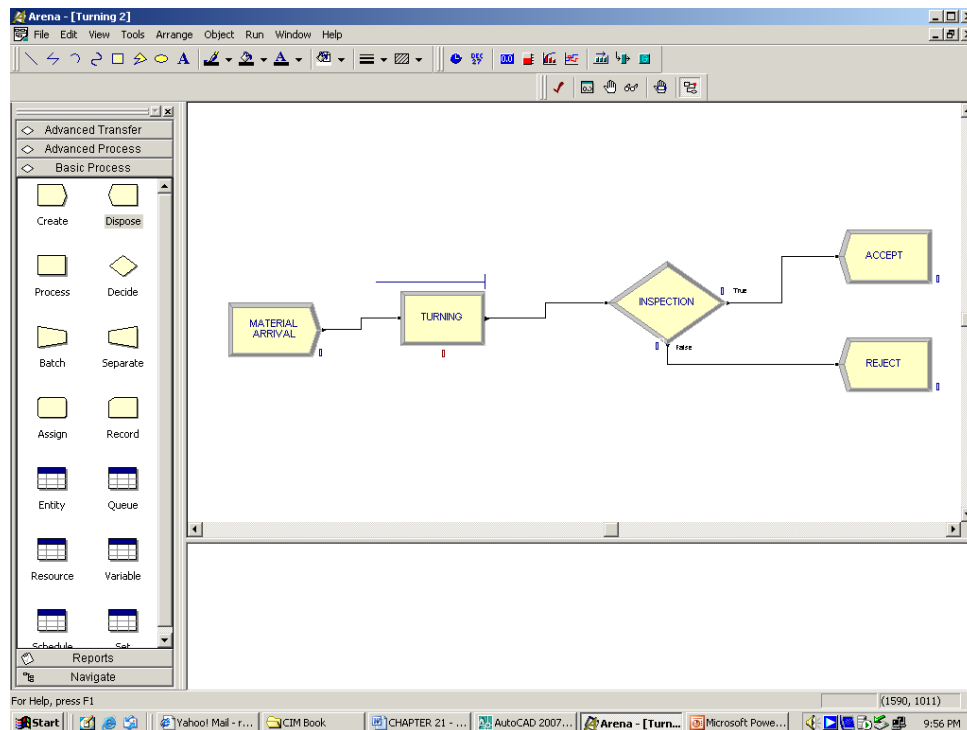
In the name field type Inspected. From the experience the process has a percentage rejection of 5%. Under percent "True" field type 95.

Click OK to close dialog box.

Double click first dispose module and in the name field type accepted.

Click OK to close dialog box.

Double click the other Dispose module and type Rejected Click OK to close dialog box.



**Fig. 21.8 Model Screen**

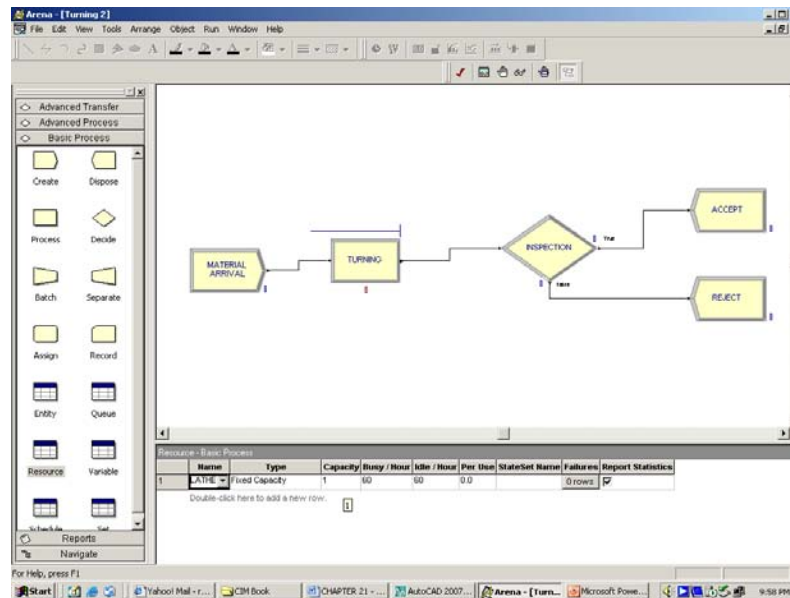
The new screen appears as shown in Fig. 21.8.

Along with the flow chart, one can define parameters.

Along with flow chart, one can also define parameters associated with other elements of the model such as resources, entities, queues etc. For the application, we will define machine hours cost of the machine so that the simulation will report the cost associated with this process. The machine hour rate is specified as Rs.60/ hour.

To incorporate these parameters to the model, we enter them in the resources spreadsheet.

In the Basic Process Panel click resources icon to display the resources spreadsheet. Click in the Busy/Hour Cell and assign the cost rate as 60/hour. Click in the idle/hour cell and assign the idle cost rate of 60.



**Fig. 21.9 Adding Resources**

### 21.7.5 SIMULATION

Since this is a simple model, we will perform an 8 hour run. Open the Project Parameters dialog by using Run> setup menu item and click project parameters tag.

Next click replication parameters tab. In the replication length field type 4. In the time unit, select hours.

Click OK to close the dialog box.

Click on save on the standard Tool bar. The model can be saved in an appropriate folder and in a suitable file name.

The simulation can be started by clicking the Go button or Run button. After checking the validity of the model, the simulation can be launched. The simulation results are then displayed on the screen.

The above description is only a brief introduction to the very powerful technique of simulation. The reader is advised to refer to the excellent text books and software manuals available on this topic.

### QUESTIONS

1. Discuss the different types of manufacturing simulation.
2. Describe various simulation techniques.
3. How does automotive industry use simulation to design manufacturing systems?
4. Describe the procedure for simulation using a simulation package.

---

# INDEX

---

## A

A CIM Model 597  
Accounts Payable 307  
Accounts Receivable 308  
ACIS 583  
Across the Wall Approach 17  
Active Edge List 67  
Analysis 220  
Anti Aliasing 72  
APPAS and CAD/CAM 290  
Application Layer 536  
Applications of Industrial Robots 496  
Arc Net Cards 532  
Artificial Intelligence 287  
Assembly Design 169  
ATM (Asynchronous Transfer Mode)  
    NETWORKS 554  
AUTAP 290  
Automated Storage and Retrieval Systems 624  
Automatic Guided Vehicles 623  
Automatic Positioning of Tools 351  
Automatic Tool Change Systems 614  
Automating Workflow 560  
Automation 327  
Autoplan 290

## B

Banded Matrix 213  
Bar Code Technology 648

Base Band 528  
Batch Production (Discrete Manufacturing) 4  
Beam 203  
Behaviour Modeling 135  
Benefits of FMS 620  
Bezier 159  
Bezier Bicubic Surface Patches 165  
Bicubic Polynomial Surface 164  
Bill of Material 304  
Bill of Materials 150  
Blocks 143  
Boundary Representation 127  
Bresenham's Algorithm 47  
Broad Band 528  
Brushless A.C. Servomotors 359  
B-SPLINES 161  
Bus Networks: 530  
Bus Topology 88  
Business Plan 296

## C

CAD BASED PROCESS PLANNING 270  
CAD/CAM-CMM Interface 519  
CAM Technology 451  
CAM-I CAPP 289  
Canned Cycles 396  
Canned Cycles (Fixed Cycles) 377  
Capacity Requirements Planning 299  
CAPP based on CAD Models 286  
CAPP based on Decision Logic 287

Casting Simulation 242  
Categories of AS/RS 625  
Cell Encoding 68  
Cell Magazine Management 636  
Central Projection 65  
Challenges in Manufacturing 2  
Chucking Machines 362  
CIM Data Base 248  
CIM Hardware 6  
CIM Model of Digital Equipment Corporation 603  
CIM software 6  
Circuit Switching 554  
CL Data Files 463  
Classification of computers 79  
Classification of robots 475  
Client/Server 549  
Clipping 63  
Closed Loop System 349  
CNC 341  
CNC CMM 511  
CNC Drilling 366  
CNC Grinding 366  
CNC Lathes 361  
CNC Machining 173  
CNC Press Brakes 371  
CNC Servo system 344  
CODE system 277  
Coding Structures 274  
Collaborative Design 572  
Collaborative Engineering 565  
Collaborative Product Development 566  
Computer Aided Manufacturing 453  
Computer Graphics. 41  
Computer Hardware 77  
Computer Software 77  
Computer to Computer Communications 87  
Conceptual Design 174  
Concurrent Engineering 18  
Constructive Solid Geometry (CSG) 126  
Continuous Process Industries 3  
Control System Features 374  
Coordinate Measuring Machine 510  
CORBA 569  
Cost Accounting 304  
CPPP 291  
Cross Hatching 144

CRT 93  
Cubic Splines 156  
Curvature Plot 178  
Curve Design 178  
Curve on Surface 184  
Curves and Surfaces 154  
Customer Order Processing 311  
Cutting Conditions 416  
Cylindrical Grinding 367

## D

Data Acquisition Systems 652  
Data Communications 83  
Data Exchange Using Neutral Files 585  
Data Link Layer 534  
Database Administrator 251  
Datum Points 403  
Datum Setting 413  
DBMS Architecture 255  
DECNET 536  
Depreciation 310  
Design and Redesign Path 17  
Design Changes 19  
Design for X 27  
Design of Curves 177  
Design Work Stations 89  
Detection of Direction 347  
Diagnostic Features 377  
Digital Differential Analyzer 43  
Digitizer 99  
Dimensioning 145  
Direct Data Translation 584  
DIRECT Numerical Control 379  
Displacement Function 192  
Displacement Functions 211  
Display 144  
Display Subsystem 92  
Distributed numerical control 384  
Distribution Planning 313  
Drafting Package 138  
Drawing Interchange Files 150  
Drawing of Circles 46  
DXF Files 585  
Dynamic Enterprise Modelling 323  
Dynamic Enterprises 315

**E**

Edge Surface 168  
EDIT Commands 143  
Electrical Discharge Machining 369  
Electronic Spindle Orientation 360  
Element Shapes 211  
Element Stiffness Matrix 192  
Elements 223  
Elements of a Robotic System 472  
Elements of FMS 622  
Encoder, 345  
End-of-Arm Movements 477  
Enquiry C 146  
Enterprise Optimization 607  
Enterprise Resource Planning 316  
Enterprise-wide Network 556  
ENTITIES 142  
ESPRIT - CIM OSA MODEL 599  
ETHERNET 537  
Ethernet Cards 532  
Ethernet Switch 551  
Ethernet Workgroup Hubs 552  
Evolution of CIM 10  
Experience-based Planning 279  
Extended Enterprises 571  
Extrusion 147

**F**

Factory Level Control 338  
Failure Mode and Effect Analysis 32  
FDDI Adapters 552  
Feature-based Design 128  
Features of a Database Management System 251  
Features of CNC Systems 373  
Feedback Signal 345  
File Transfer Protocol 549  
File Utilities 142  
Finite Element Analysis Packages 215  
Finite Element Modeling 173  
Finite Element Modeling (FEM) and Finite Element 189  
Fixed Beam Reader 649

Flexible Inspection System 520  
Flexible Machining Systems 619  
Flexible Manufacturing Cells 612  
Flexible Manufacturing System (FMS) 609  
Flexible Transfer Lines 619  
Flexible Turning Cells 613  
FMC Software 629  
Forward and Backward Planning 286  
Frame Buffer 95  
Frame Buffers 68  
Frontal Solver Technique 214  
Functions Available in a Typical CNC System 384

**G**

G Functions 407  
Gantry Robot 476  
GARI 291  
Gauraud Shading 75  
Gear Cutting Machines 370  
General Ledger 309  
General Purpose Simulation System 655  
Generative process Planning 284  
Geometric modeling 121  
Geometry Engine 91  
GKS 576  
Global Stiffness Matrix 193, 212  
Graphic Primitives 42  
Graphic Standards 575  
Graphical User Interfaces 113  
Grid 140  
Group Technology 272  
GUI 113

**H**

Heat Treatment 245  
Hidden Surface Removal 70  
Hierarchical Database 252  
High Speed Machining Centres 360  
High-Level Simulators 655  
Homogeneous Transformations 60  
Horizontal Spindle Machining Centres 355  
Hybrid Networks: 530  
Hybrid Schemes 88

**I**

IBM Concept of CIM 604  
 IGES 587  
 Input Format 286  
 Inspection Machines 373  
 Interactive Graphic Terminals 93  
 INTERNET 548  
 Interpolation 394  
 Intranet 550  
 Inventory Management 302  
 Isometric Projection 66

**J**

Job Costing 306  
 Job Scheduling 631  
 Joysticks 97

**K**

Keyboard 82, 97

**L**

Labour Performance 313  
 Ladder Logic 334  
 LAN Adapters 551  
 Laser Interferometer 513  
 Laser Telemetric Measuring Systems 513  
 Layers 141  
 Levels of Integration 10, 605  
 Life of a Product 14  
 LINUX 120  
 Local Area Network (LAN) 526

**M**

Machining Centres 354  
 Main Frame Computer 82  
 Manual Part Programming 404  
 Manufacturing Automation 328  
 Manufacturing Automation Protocol 536  
 Manufacturing Model 457  
 Manufacturing resource planning 293  
 Manufacturing Simulation 195, 653

Mass Production Industries 3  
 Master Production Schedule 297  
 Materials Requirements Planning 298  
 M-Codes 410  
 Mechanism Design 171  
 Mesh Refinement 191  
 MICLASS Classification 277  
 Mini Computers 82  
 MIPLAN 289  
 Miscellaneous Codes 392  
 Modems 87, 531  
 Mother Board 81  
 Mouse 98  
 Moving Beam Reader 649  
 MRP 294  
 MRP-II SOFTWARE 314  
 MS WINDOWS 114  
 MULTICAPP 289  
 Multitasking Machines 364

**N**

NC POST-PROCESSING 464  
 Network Database 253  
 Network File System (NFS) 543  
 Network Layer 535  
 Network Operating Systems 540  
 Network Techniques 526  
 Network Topologies 530  
 Network Wiring Methods 529  
 Networking 523  
 Non-contact CNC CMM 515  
 Numerical Control 341  
 NURBS 162

**O**

Objectives of Database 250  
 Off-line (batch) Data Collection Systems 647  
 Oil Hydraulic Systems 329  
 On-line Data Collection 646  
 OpenGL 580  
 Operating Systems 103  
 Opitz Classification System 275  
 Optical Character Recognition 650  
 Order Progress 645  
 Order Release 644  
 Order Scheduling 645

OSI Model 533  
Outsourcing 37  
Overview of Pentium PC 80

## P

Packet Switching 554  
Paperless Office 557  
Parallel Interface 84  
Parallel Projection 64  
Parallel/Serial Conversion 85  
Parametric Design 132  
Parasolid 581  
Part Families 272  
Parts Classification and Coding Systems 272  
Payroll 310  
Personal Computers 79  
Perspective projection 65  
PHIGS 578  
Phong Technique 75  
Physical Layer 534  
Plane Stress/Plane Strain 205  
Plastic Injection Molding 245  
PLC applications 331  
PLM softwares 36  
Plotters 101  
Pneumatic Systems 328  
Post Process Metrology 516  
Postprocessor 221  
Preparatory Codes 392  
Preparatory Functions 407  
Preprocessing 217  
Presentation Layer 536  
Principal Stresses 206  
Printers 102  
Procedure for Simulation 659  
Process Boundaries. 281  
Process Boundary Table 281  
Process Capability 280  
Process Control: 330  
Process Family Matrix 282  
Process Planning 263  
Process Selection 279  
Product Data Management 258  
Product Development Cycle 13  
Product Development Spiral 16  
Product Life Cycle Management 35  
Production Plan 297

Programmable Logic controller 377  
Programmable Logic Controllers 329  
Programming Codes 412  
Programming Features 376, 389  
Programming of PLC 333  
Projections 64  
Public Switched Data Networks 525  
Purchase Order and Receiving 302

## Q

Quality Control 505  
Query Language 255

## R

Raster Sca 94  
Raster Subsystem 92  
Rasterizing Polygons 69  
Real time Scan Conversion 67  
Reflection 73  
Rendering 69  
Retrieval of Plans 268  
Revolution 148  
Ring Network 88, 530  
Robot Programming 486  
Robot Programming Languages 489  
Robots 471  
Robust Design 34  
Rotation 58  
Router 553  
RPO 290  
RS-232 Interface 86  
Ruled Surface 167  
Run Length Encoding 68

## S

Sales History 312  
Scaling 140  
Scaling 57  
Scan Conversion 66, 91  
Scan Converting Polygons 69  
Scan Line Z-Buffer Algo 72  
SCARA Robot 476  
Seed Fill Algorithm 70  
Sequencing: 330



Sequential Engineering 16  
 Session Layer 535  
 Shading 75  
 Shearing 59  
 Shop Floor Control 643  
 Shop Floor Data Collection 641  
 Siemens Model of CIM 602  
 Simulation in Automotive Industry 657  
 Simulation Languages 655  
 Simulation Software Packages 656  
 Simultaneous Engineering 18  
 Singularity 179  
 Smart Cards 651  
 Smoothness of surfaces 184  
 Snap 140  
 Solar Cells 346  
 Solid Modeling 125  
 Spar 199  
 Spindle Cooling 359  
 Splines 156  
 Spring Element 197  
 Standard Product Costing 306  
 Standard Product Routing 305  
 Star Network: 530  
 Star Topology 88  
 Statistical Process Control (SPC) 509  
 STEP architecture 591  
 Steps in FEA 217  
 Structural Analysis 193  
 Structured Query Language 256  
 Subroutine Programming 376  
 Super Computers 83  
 Supply Chain Management 320  
 Surface Grinding 366  
 Surface Modeling 124, 152  
 Surface Patch 164  
 Switching: 330  
 System Network Architecture 536

## T

Tabulated Surface 167  
 Taguchi Method 34  
 Technical Document Management 558  
 Technical Office Protocol 537

Technology of CAM 454  
 THE NIST - AMRF Hierarchical Model 601  
 Thumb Wheel 100  
 TIPPS 291  
 Token-Ring Adapters 553  
 Tool Nose Radius Compensation 403  
 Tool Offset/Tool Compensation 402  
 Total Quality Management (TQM) 506  
 Touch Screens 97  
 Toyota Production System 32  
 Track Balls 98  
 Transformation 55  
 Translation 58  
 Transmission Media 531  
 Transport Layer 535  
 Turning Centres 361  
 Turret Punch Press 369  
 Turret Slide 363  
 Types of CNC Machines 353  
 Types of Production Systems 612  
 Typical FMS Layout 638

## U

Units 140  
 Universal Lathes 362  
 Universal Machining Centres 358  
 Universal Serial Bus 87  
 UNIX 108  
 Unix Kernel 108  
 User Co-ordinate Systems 148

## V

Value Engineering 34  
 Value Stream Mapping 32  
 Variant Process Planning 282  
 Vector Spindle Drive 359  
 vertical CNC Lathes 364  
 Vertical Spindle Machining Centres 357  
 View Port 56  
 Virtual Machining 451, 464  
 Virtual Manufacturing 322  
 Virtual Private Network 525  
 Vision System 514

Voice Recognition 651  
VSAT 556

**W**

Wave Front 214  
Welding Simulation 243  
Wire Frame Modeling 123

Wireless LAN (WLAN) 89  
Wireless LAN Adapters 552  
Work Envelope of a Robot 478  
Workflow Management Systems 561  
World Wide Web 549

**Z**

Z-Buffer Algorithm 71

